

INSTRUCTION MANUAL

Model 145

145-S-620, 145-S-872 & 145-S-1021

20 MHz Pulse/Function
Generator

INSTRUCTION MANUAL

Model 145

145-S-620, 145-S-872 & 145-S-1021

20 MHz Pulse/Function Generator

© 1983 Wavetek

This document contains information proprietary to Wavetek and is provided solely for instrument operation and maintenance. The information in this document may not be duplicated in any manner without the prior approval in writing from Wavetek.

Model 145-S-620 is a standard Wavetek Model 145 modified to provide a SYMMETRY control on the rear panel. This control allows the waveform time symmetry to be continuously adjusted over a 19:1 to 1:19 range. When this control is switched on, the generator operates at approximately 1/10 of the selected frequency. All procedures and descriptions in this manual assume that the SYMMETRY control is in the OFF position.

Model 145-S-872 is identical to the standard Model 145 except for the addition of an elapsed time meter installed on the rear panel.

Model 145-S-1021 is identical to the standard Model 145 except for the addition of both the SYMMETRY control and an elapsed time meter installed on the rear panel.

Option parts lists, assembly drawings and schematics as well as those for the Standard Model 145 are contained in Section 7 of this manual.

**Wavetek
Instruments Division**

9045 Balboa Ave.
San Diego, CA 92123
Tel: (619) 279-2200
800-223-9885
Fax: (619) 565-7942

Manual Revision 3/92
Manual Part Number 1300-00-0101

WARRANTY

Wavetek warrants that all products manufactured by Wavetek conform to published Wavetek specifications and are free from defects in materials and workmanship for a period of one (1) year from the date of delivery when used under normal conditions and within the service conditions for which they were furnished.

The obligation of Wavetek arising from a Warranty claim shall be limited to repairing, or at its option, replacing without charge, any product which in Wavetek's sole opinion proves to be defective within the scope of the Warranty. In the event Wavetek is not able to modify, repair or replace non-conforming defective parts or components to a condition as warranted within a reasonable time after receipt thereof, Buyers shall be credited for their value at the original purchase price.

Wavetek must be notified in writing of the defect or nonconformity within the Warranty period and the affected product returned to Wavetek's factory or to an authorized service center within (30) days after discovery of such defect or nonconformity.

For product warranties requiring return to Wavetek, products must be returned to a service facility designated by Wavetek. Buyer shall prepay shipping charges, taxes, duties and insurance for products returned to Wavetek for warranty service. Except for products returned to Buyer from another country, Wavetek shall pay for return of products to Buyer.

Wavetek shall have no responsibility hereunder for any defect or damage caused by improper storage, improper installation, unauthorized modification, misuse, neglect, inadequate maintenance, accident or for any product which has been repaired or altered by anyone other than Wavetek or its authorized representative and not in accordance with instructions furnished by Wavetek.

Exclusion of Other Warranties

The Warranty described above is Buyer's sole and exclusive remedy and no other warranty, whether written or oral, is expressed or implied. Wavetek specifically disclaims the implied warranties of merchantability and fitness for a particular purpose. No statement, representation, agreement, or understanding, oral or written, made by an agent, distributor, representative, or employee of Wavetek, which is not contained in the foregoing Warranty will be binding upon Wavetek, unless made in writing and executed by an authorized Wavetek employee. **Under no circumstances shall Wavetek be liable for any direct, indirect, special, incidental, or consequential damages, expenses, losses or delays (including loss of profits) based on contract, tort, or any other legal theory.**

CONTENTS

SECTION 1 GENERAL DESCRIPTION

1.1	MODEL 145.....	1-1
1.2	SPECIFICATIONS	1-1
1.3	EQUIPMENT REQUIRED	1-2

SECTION 2 INITIAL PREPARATION

2.1	MECHANICAL INSTALLATION.....	2-1
2.2	ELECTRICAL INSTALLATION.....	2-1
2.3	ELECTRICAL ACCEPTANCE CHECK.....	2-1
2.4	PREPARATION FOR SHIPMENT.....	2-4
2.5	PREPARATION FOR STORAGE.....	2-4
2.6	PREPARATION FOR EXTENDED STORAGE.....	2-4

SECTION 3 OPERATION

3.1	CONTROLS AND CONNECTIONS	3-1
3.2	OPERATION.....	3-4
3.2.1	Signal Termination	3-4
3.2.2	Pulses.....	3-5
3.2.3	Waveforms	3-5
3.2.4	Voltage Controlled Function Generator Operation	3-6
3.2.5	Delay of Triggered Pulse.....	3-7

SECTION 4 CIRCUIT DESCRIPTION

4.1	BASIC WAVEFORM DEVELOPMENT	4-1
4.2	AMPLITUDE, OFFSET AND ATTENUATION.....	4-2
4.3	TRIGGER AND GATE CONTROL	4-2
4.4	PULSE OUTPUTS.....	4-2
4.5	WIDTH AND DELAY ONE-SHOTS	4-3

SECTION 5 MAINTENANCE

5.1	FACTORY REPAIR	5-1
5.2	INSPECTION AND PERFORMANCE VERIFICATION	5-1
5.3	REQUIRED TEST EQUIPMENT	5-1
5.4	REMOVING GENERATOR COVERS	5-1
5.5	CALIBRATION.....	5-1

SECTION 6 TROUBLESHOOTING

6.1	FACTORY REPAIR	6-1
6.2	TROUBLESHOOTING CHARTS.....	6-1
6.3	TROUBLESHOOTING INDIVIDUAL COMPONENTS	6-1
6.4	DISSEMBLY/REASSEMBLY INSTRUCTIONS FOR BENCH INSTRUMENT.....	6-2
6.5	DISSEMBLY/REASSEMBLY INSTRUCTIONS FOR RACK MOUNTED INSTRUMENT	6-3

CONTENTS (Continued)

SECTION 7 PARTS LIST AND SCHEMATICS

7.1	DRAWINGS	7-1
7.2	ERRATA	7-1
7.3	ORDERING	7-1
7.4	INDEX OF FEDERAL SUPPLY CODES	7-1
7.5	CAPACITOR VARIANCE	7-3

ILLUSTRATIONS

Figure	Title	Page
2-1	Initial Setup	2-2
2-2	Second Setup	2-3
3-1	Controls and Connectors	3-1
3-2	Signal Termination	3-4
3-3	ECL Terminations	3-4
3-4	Pulse Characteristics	3-5
3-5	Waveform Characteristics	3-6
3-6	VCG Voltage-to-Frequency Nomograph	3-7
3-7	Pulse Delay From Trigger	3-7
4-1	Overall Block Diagram	4-0
4-2	Basic Generator and Timing Diagram	4-1
4-3	Trigger Circuit and Timing	4-3
4-4	Normal Mode Timing	4-4
4-5	Delayed Mode Timing	4-4
4-6	Double Mode Timing	4-5
4-7	Width and Delay One-Shots	4-5
5-1	Generator Board	5-5
5-2	Trig/Pulse Board	5-7
6-1	Initial Checks, Generator Board	6-6
6-2	Generator Loop Checks, Generator Board	6-7
6-3	VCG Checks, Generator Board	6-8
6-4	Generator Output Checks, Generator Board	6-9
6-5	Trigger and Gate Mode Checks, Trig/Pulse Board	6-10
6-6	Power Supply Checks, Trig/Pulse Board	6-12
6-7	Generator Input and Output Checks	6-14
6-8	Pulse Mode Checks, Trig/Pulse Board	6-16
6-9	Pulse Generator Checks, Trig/Pulse Board	6-18

NOTE

The following illustrations appear at the rear of this manual in the order shown.

Drawing Number	Title
0102-00-0101	Instrument Assembly and Parts List
0004-00-0101	Instrument Schematic
0102-00-0575	Chassis Assembly
1101-00-0575	Chassis Assembly Parts List



ILLUSTRATIONS (Continued)

Drawing Number	Title
0103-00-0556	Generator Board Schematic
1100-00-0556	Generator Board Parts Locator
0101-00-0556	Generator Board Assembly (Sheets 2 and 3)
1100-00-0556	Generator Board Parts List
0101-00-1008	Current Limiter Board Parts Locator and Parts List
0103-00-0565	Trigger/Pulse Board Schematic
1100-00-0565	Trigger/Pulse Board Parts Locator
0101-00-0565	Trigger/Pulse Board Assembly (Sheet 2)
1100-00-0565	Trigger/Pulse Board Parts List
0102-00-0621	Rack Mount Assembly and Parts List
1101-00-3243	Chassis Assembly
1100-00-3243	Chassis Parts List
1104-00-3245	Generator Board Schematic
1101-00-3245	Generator Board Assembly
1100-00-3245	Generator Board Parts List
0102-00-0221	Option 001 5000 Hour Timer Assembly and Parts List
0102-00-0442	Option 003 5000 Hour Timer Assembly
1000-00-0442	Option 003 5000 Hour Timer Parts List

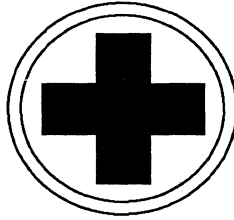
SAFETY FIRST



PROTECT YOURSELF. Follow these precautions:

- Don't touch the outputs of the instrument or any exposed test wiring carrying the output signals. This instrument can generate hazardous voltages and currents.
- Don't bypass the power cord's ground lead with two-wire extension cords or plug adaptors.
- Don't disconnect the green and yellow safety-earth-ground wire that connects the ground lug of the power receptacle to the chassis ground terminal (marked with  or ).
- Don't hold your eyes extremely close to an rf output for a long time. The normally nonhazardous low-power rf energy generated by the instrument could possibly cause eye injury.
- Don't plug in the power cord until directed to by the installation instructions.
- Don't repair the instrument unless you are a qualified electronics technician and know how to work with hazardous voltages.
- Pay attention to the **WARNING** statements. They point out situations that can cause injury or death.
- Pay attention to the **CAUTION** statements. They point out situations that can cause equipment damage.

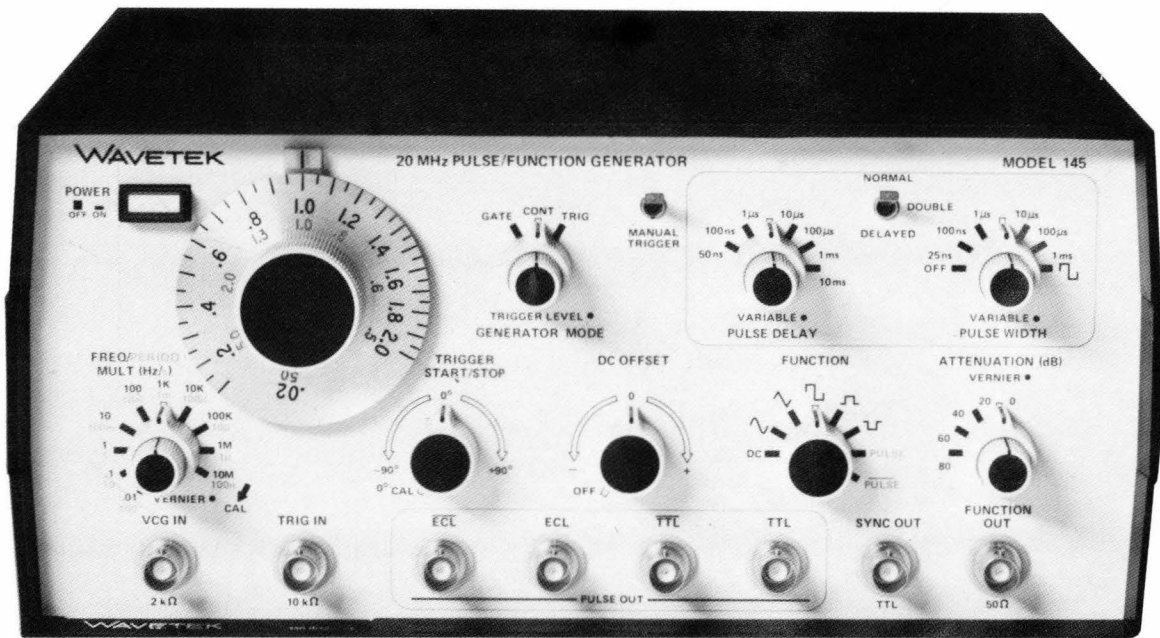

Model 145, 20 MHz Function/Pulse Generator

SECTION 1

GENERAL DESCRIPTION

1.1 THE MODEL 145

The Model 145 20 MHz Pulse/Function Generator has the versatility of output found in a function generator, plus the pulse characteristics of a pulse generator. It is a precision source of sine, triangle, balanced square, positive square and negative square waveforms, a source of dc levels and a source of normal and inverted pulses. All are front panel and remote control variable from 0.0001 Hz to 20 MHz (periods from 50 ns to 10,000s). Pulse widths are variable from 25 ns to 1 ms and pulse delays variable from 50 ns to 10 ms. Double pulses (two pulses per period) are also available with variable time between pulses. The logical complement of the pulse is selectable and either pulse or complement are output simultaneously as ECL, $\overline{\text{ECL}}$, TTL, $\overline{\text{TTL}}$ and variable amplitude and offset pulses.

The amplitude controllable output of either waveform or pulse can be varied to 30 volts peak-to-peak (open circuit) and attenuated up to 80 dB. DC voltage or dc offset of signal is variable by front panel control and by external control between ± 15 volts (open circuit). The outputs are also triggerable for one or multiple cycles by front panel switch or remote signal. A voltage representing generator frequency and a TTL level sync pulse at the frequency of the generator are auxiliary outputs.

1.2 SPECIFICATIONS

1.2.1 Versatility

Instrument operates as either a function generator or pulse generator.

1.2.2 Function Generator

Waveforms

Selectable sine \sin , square \square , triangle \triangle , positive square \sqcap , negative square \sqcup and dc. TTL sync pulse and fixed amplitude pulses of TTL, $\overline{\text{TTL}}$, ECL and $\overline{\text{ECL}}$, all simultaneously available with function output.

Operational Modes

Continuous: Generator oscillates continuously at selected frequency.

Triggered: Generator is quiescent until triggered by an

external signal or manual trigger, then generates one cycle at selected frequency.

Gated: As triggered mode, except generator oscillates for the duration of the gate signal.

Frequency Range

0.0001 Hz to 20 MHz in 10 overlapping ranges with approximately 1% vernier control.

Function Output

\sin , \square , \triangle selectable and variable to 30 Vp-p (15 Vp-p into 50 Ω). \sqcap , \sqcup , to 15 Vp (7.5 Vp into 50 Ω). All waveforms and dc can supply 150 mA peak current and may be attenuated to 60 dB in 20 dB steps with an additional 20 dB vernier.

DC Output and DC Offset

Selectable thru FUNCTION OUT output. Controlled by front panel control or by applying an external voltage. Adjustable between a minimum of ± 14.4 Vdc (± 7.2 Vdc into 50 Ω) with signal peak plus offset limited to ± 14.4 Vdc (± 7.2 Vdc into 50 Ω). External offset sensitivity approximately -1 V/V with output into open circuit. DC offset and output waveform attenuated proportionately the 60 dB output attenuator.

Sync Output

A TTL level pulse. Will drive 50 Ω termination.

GCV—Generator Controlled Voltage

At GCV OUT connector, a 0 to +2V signal proportional to generator frequency. 600 Ω source impedance.

VCG—Voltage Controlled Generator

Up to 1000:1 frequency change with external 0 to 2 volt signal to VCG IN connector. Upper and lower frequencies limited to maximum and minimum of selected range.

Slew Rate: 2% of range per μs .

Linearity:

$\pm 0.2\%$ for 10 Hz to 200 kHz.

$\pm 0.75\%$ for 0.001 Hz to 2 MHz.

Impedance: 2 k Ω .

Trigger and Gate

Input Range: 1 Vp-p to $\pm 10\text{V}$.

Impedance: 10 k Ω , 33 pF.
Pulse Width: 25 ns minimum.
Repetition Rate: 10 MHz maximum.
Adjustable Triggered Signal Start/Stop Point (sine and triangle only): Approximately -90° to $+90^\circ$ to 2 MHz.

1.2.3 Frequency Precision

Dial Accuracy

$\pm 3\%$ of full range from X .01 Hz to X 1 MHz.
 $\pm 5\%$ of full range on X 10 MHz.

Time Symmetry

Square wave variation less than:
 $\pm 1\%$ from 0.001 Hz to 200 kHz
 $\pm 0.5\%$ from 20 Hz to 20 kHz

1.2.4 Amplitude Precision

Amplitude Change With Frequency

Sine variation less than:
 ± 0.1 dB for 0.001 Hz to 200 kHz
 ± 0.5 dB for 200 kHz to 2 MHz
 ± 3.0 dB for 2 to 20 MHz

Step Attenuator Accuracy

0.3 dB per 20 dB step at 2 kHz.

1.2.5 Waveform Characteristics

Sine Distortion

$< 0.5\%$ on X 100 Hz to X 10 kHz.
 $< 1.0\%$ on X .01 to X 10 Hz and X 100 kHz.
All harmonics 34 dB below fundamental on X 1 MHz.
All harmonics 26 dB below fundamental on X 10 MHz.

Square Wave Rise/Fall Times

At FUNCTION OUT < 20 ns for 15V p-p output into 50 Ω load.

1.2.6 Pulse Generator

Pulse Outputs

Variable amplitude pulse, and simultaneous fixed ECL, $\overline{\text{ECL}}$, TTL and $\overline{\text{TTL}}$ pulses and TTL sync pulse. All outputs can drive 50 Ω terminations.

Operational Modes

Continuous, triggered and gated plus the following.
Normal Pulse: Adjustable width pulse in phase with sync signal.
Delayed Pulse: Pulse delayed with respect to normal pulse. Pulse delay and pulse width adjustable.
Double Pulse: Two pulses for every period. Time between pulses and pulse width adjustable. Minimum period 100 ns.

Pulse Period Range

50 ns to 10,000s*in 10 overlapping ranges with approximately 1% vernier control.

Pulse Width

25 ns to 1 ms in 5 overlapping ranges with vernier control. Includes OFF and square wave.

Pulse Delay

50 ns to 10 ms in 6 overlapping ranges with vernier control.

Duty Cycle

Duty cycles to 70% for periods > 100 ns (< 10 MHz); for periods < 100 ns (> 10 MHz) duty cycles are approximately 50%.

Function Output

Variable to 30V p-p (15V p-p into 50 Ω). DC offset and attenuation are same as for function generator.

Pulse Rise/Fall Times

At FUNCTION OUT, < 20 ns for 15V p-p output into 50 Ω load.

1.2.7 General

Stability

Short Term: $\pm 0.05\%$ for 10 minutes.
Long Term: $\pm 0.25\%$ for 24 hours.
Percentages apply to amplitude, frequency and dc offset.

Environmental

Specifications apply at $23^\circ\text{C} \pm 5^\circ\text{C}$. Instrument will operate from 0°C to 50°C ambient temperatures.

Dimensions

28.6 cm (11 $\frac{1}{4}$ in.) wide; 13.3 cm (5 $\frac{1}{4}$ in.) high; 27.3 cm (10 $\frac{3}{4}$ in.) deep.

Weight

5 kg (11 lb) net; 6.6 kg (14 $\frac{1}{2}$ lb) shipping.

Power

90 to 105V, 108 to 126V, 198 to 231V and 216 to 252V selectable; 48 to 400 Hz; less than 30 watts.

NOTE

All specifications apply from 0.1 to 2.0 on frequency dial when FUNCTION OUT output is at maximum and 50 Ω terminated. Function generator specifications apply when PULSE WIDTH control is OFF.

1.3 EQUIPMENT REQUIRED

Equipment required is given in table 1-1.

Table 1-1. Equipment Required But Not Supplied

Equipment	Manufacturer's Part Number	Alternate Part Number	Application Acceptance	Calibration
Oscilloscope	TEK 465	TEK 475	X	X
Voltmeter	Fluke 8000A	Fluke 8010A		X
Distortion Analyzer	HP334A			X
Counter	HP5300B	HP5345A		X
Function Generator	Wavetek 180	Wavetek 148	X	X
DC Voltage Source	JF 332		X	X
50Ω Termination	TEK 011-0099-00	Fluke Y9103		X
3 Foot Coax Cables	TEK 012-0057-01	Pomona 4964-SS-36	X	X
Coax Tee Connector	TEK 103-0030-00	Pomona 3285	X	

SECTION 2 INSTALLATION

2.1 MECHANICAL INSTALLATION

After unpacking the instrument, visually inspect all external parts for possible damage to connectors, surface areas, etc. If damage is discovered, file a claim with the carrier who transported the unit. The shipping container and packing material should be saved in case reshipment is required.

2.2 ELECTRICAL INSTALLATION

2.2.1 Power Connection

WARNING

To preclude injury or death due to shock, the third wire earth ground must be continuous to the facility power outlet. Before connecting to the facility power outlet, examine extension cords, autotransformers, etc., between the instrument and the facility power outlet for a continuous earth ground path. The earth ground path can be identified at the plug on the instrument power cord; of the three terminals, the earth ground terminal is the nonmatching shape, usually cylindrical.

CAUTION

To prevent damage to the instrument, check for proper match of line and instrument voltage and proper fuse type and rating.

NOTE

Unless otherwise specified at the time of purchase, this instrument was shipped from the factory with the power transformer connected for operation on a 108 to 132 Vac line supply and with a 0.5 amp slow blow fuse.

Conversion to other input voltages requires a change in rear panel fuse-holder voltage card position and slow blow fuse according to the following table and procedure.

Card Position	Input Vac	Fuse
100	90 to 105	0.5 amp
120	108 to 126	0.5 amp
220	198 to 231	0.25 amp
240	216 to 252	0.25 amp

1. Open fuse holder cover door and rotate fuse pull to left to remove the fuse.

2. Select operating voltage by orienting the printed circuit board to position the desired voltage on the top left side. Push the board firmly into its module slot.
3. Rotate the fuse-pull back into the normal position and insert the correct fuse into the fuse holder. Close the cover door.
4. Connect the ac line cord to the mating connector at the rear of the unit and the power source.

2.2.2 Signal Connections

Use 3 foot RG58U 50Ω shielded cables equipped with female BNC connectors to distribute all input and output signals.

2.3 ELECTRICAL ACCEPTANCE CHECK

This checkout procedure is a general verification of generator operation: Should a malfunction be found, refer to the warranty in the front of this manual.

Refer to table 1-1 for equipment required for this procedure.

Preset the generator front panel controls as follows:

Set up the oscilloscope, Model 145 and external generator as shown in figure 2-1.

Control	Position
Dial	1.0
GENERATOR MODE	CONT
TRIGGER LEVEL	9 o'clock
PULSE DELAY	1 μs 10 μs
PULSE DELAY VARIABLE	12 o'clock
NORMAL/DOUBLE/DELAYED	NORMAL
PULSE WIDTH	OFF
PULSE WIDTH VARIABLE	12 o'clock
ATTENUATION	0
ATTENUATION VERNIER	Full cw
FUNCTION	□
DC OFFSET	OFF
TRIGGER START/STOP	0° CAL
FREQ/PERIOD MULT	1K
VERNIER	Full cw

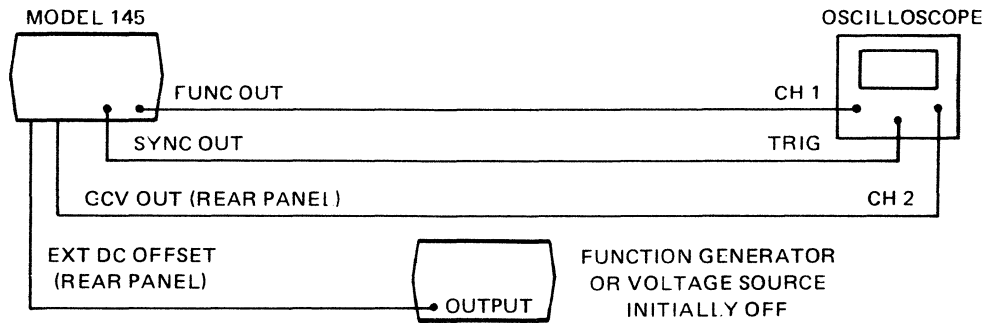

Figure 2-1. Initial Setup

Table 2-1. Acceptance Procedure

Step	Control	Position/Operation	Observe
1	POWER	ON	1 kHz square wave.
2	Dial	Rotate dial. Return to 1.0.	Rotation ccw increases frequency of square on one channel and dc level on other channel; cw decreases frequency and dc level.
3	FREQ/PERIOD MULT	Rotate switch. Return to 1K.	Rotation cw increases frequency; ccw decreases frequency (dc level not affected).
4	VERNIER	Rotate ccw. Return to CAL.	Rotation ccw gives a small decrease in frequency.
5	ATTENUATION	Rotate ccw. Return to 0.	Rotation ccw reduces square wave amplitude.
6	ATTENUATION VERNIER	Rotate ccw.	Square wave amplitude decreases.
7	DC OFFSET	Rotate cw. Return to OFF.	Square wave is immediately offset below previous level; then waveform moves up to a positive level. OFF returns waveform to original position. (Clipping occurs at $\pm 15V$.)
8	Function Generator or Voltage Source	Vary input voltage.	Waveform dc level varies.

Remove EXT DC OFFSET IN cable and connect to VCG IN connector. Remove GCV OUT cable.

9	Function Generator or Voltage Source	Vary input voltage; then disconnect input.	Frequency increases with increased voltage, decreases with decreased voltage.
10	ATTENUATION VERNIER	Rotate cw.	Square wave amplitude increases.
11	FUNCTION	Rotate to DC, \sim , \wedge , \sqcap , \sqcup , \sqsubset , then \sim .	Note dc level on scope. \sim , \wedge and \sqcap should be centered on dc level. \sqcup should rest on dc level, \sqsubset should rise to dc level.
12	GENERATOR MODE	GATE	A dc level.
13	MANUAL TRIG	Press down.	A series of sine waves.

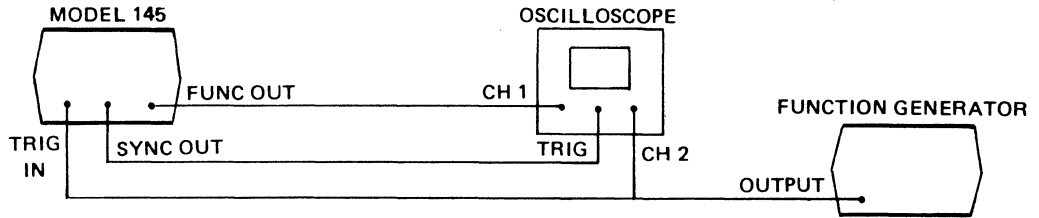

Figure 2-2. Second Setup

Table 2-1. Acceptance Procedure (Continued)

Step	Control	Position/Operation	Observe
Set up a trigger source as shown in figure 2-2. Trigger on triangle waveform. Set trigger source at 100 Hz ∇ .			
14	TRIGGER LEVEL	Rotate knob. Set for several cycles.	Knob varies number of cycles gated.
15	GENERATOR MODE	TRIG	One cycle per trigger cycle.
16	TRIGGER START/STOP	Rotate knob, then to 0° CAL.	CW starts sine wave at +90°; ccw starts sine wave at -90°. Fully cw gives continuous sine waves.

NOTE: Select square wave on trigger source.

17	FUNCTION	PULSE	DC level (minus).
18	PULSE WIDTH	Turn cw to 100 μ s 1 ms.	Pulse appears.
19	PULSE WIDTH VARIABLE	Rotate, then to 12 o'clock	CW increases pulse width; ccw decreases pulse width.
20	FUNCTION	PULSE, then $\overline{\text{PULSE}}$.	Pulse direction reverses; dc levels remain the same values.
21	NORMAL/DOUBLE/ DELAYED Switch	DELAYED	No change.
22	PULSE DELAYED	100 μ s 1 ms	Small horizontal shift.
23	PULSE DELAYED VARIABLE	Turn knob.	Pulse moves horizontally.
24	NORMAL/DOUBLE/ DELAYED Switch	DOUBLE	No change.
25	PULSE DELAYED VARIABLE	Turn knob to resolve two pulses.	Double pulse appears.

2.4 PREPARATION FOR SHIPMENT

If original packing material was saved, pack instrument in same manner as received. When using packing materials other than original, use the following guidelines:

1. Wrap instrument in plastic packing material.
2. Use double-wall cardboard shipping container.
3. Protect all sides with shock-absorbing material such as styrofoam dunnage to prevent instrument movement within the container.
4. Seal shipping container with approved sealing tape.
5. Mark FRAGILE on all sides, top and bottom of shipping container.

2.5 PREPARATION FOR STORAGE

This instrument should be stored in a clean, dry environment. The following limitations apply to both storage and reshipment.

1. Temperature within -55°C to $+75^{\circ}\text{C}$ range.
2. Relativity humidity not to exceed 95% at $+25^{\circ}\text{C}$ and sea level (non-condensing).
3. Altitude from sea level to 40,000 feet.

2.6 PREPARATION FOR EXTENDED STORAGE

For extended storage greater than 6 months, pack instrument as indicated for shipment.

SECTION 3

OPERATION

3.1 CONTROLS AND CONNECTIONS

The generator front panel controls and connectors are shown in figure 3-1 and keyed to the following descriptions.

① POWER Switch

Turns generator on and off.

② Frequency Dial

Settings under the dial index mark multiplied by ⑰ determine the output signal frequency. The dial calibration marks correspond to the frequency (black) numbers only. The period (grey) numbers are approximations only. Refer to table 3-1 for quick period/frequency conversion. The frequency can be varied by the vernier ⑰ and the VCG signal ⑱

③ GENERATOR MODE Switch

Selects one of the following three modes.

CONT – Continuous output at FUNCTION OUT, SYNC OUT and, if PULSE WIDTH is on, PULSE OUT connectors.

TRIG – DC level output at all six output connectors until the generator is triggered by MANUAL TRIGGER switch or with a signal at the TRIG IN connector. When triggered, the generator output is one cycle of waveform or one pulse period followed by a dc level.

GATE – As for TRIG except the output is continuous for the duration of the trigger signal at TRIG IN. The last cycle or period started is completed.

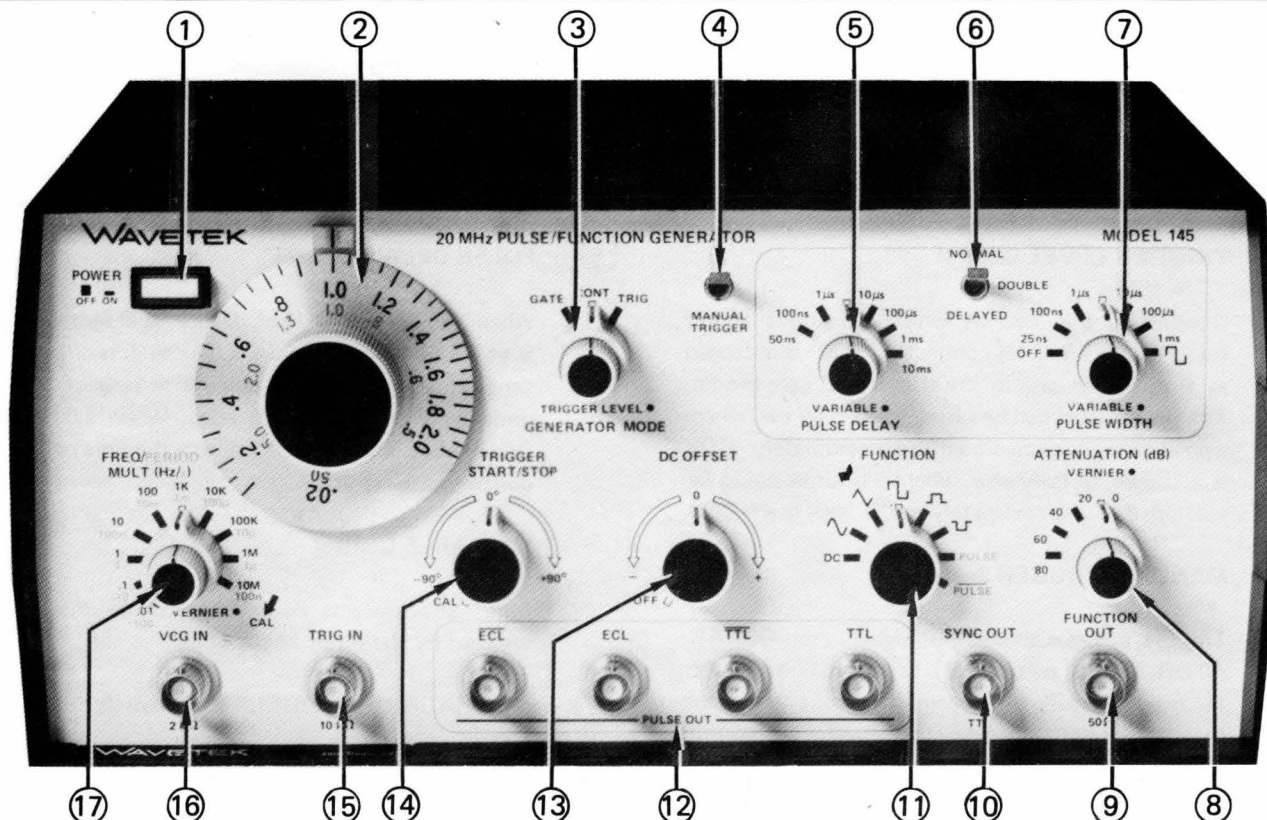

Figure 3-1. Controls and Connectors

Table 3-1. Period to Frequency Conversion

Converted Frequency Dial Values
(Based on $f = 1/T$ where \square)
 $\leftarrow T \rightarrow$

Time	Freq	Time	Freq	Time	Freq
.5	2	2.3	.44	4.1	.24
.6	1.67	2.4	.42	4.2	.24
.7	1.43	2.5	.4	4.3	.23
.8	1.25	2.6	.39	4.4	.23
.9	1.11	2.7	.37	4.5	.22
1	1	2.8	.36	4.6	.22
1.1	.91	2.9	.35	4.7	.21
1.2	.83	3	.33	4.8	.21
1.3	.77	3.1	.32	4.9	.2
1.4	.71	3.2	.31	5	.2
1.5	.67	3.3	.3		
1.6	.63	3.4	.29		
1.7	.59	3.5	.29		
1.8	.56	3.6	.28		
1.9	.53	3.7	.27		
2	.5	3.8	.26		
2.1	.48	3.9	.26		
2.2	.46	4	.25		

Symbols
M = 10^6
k = 10^3
m = 10^{-3}
 μ = 10^{-6}
n = 10^{-9}

To use the dial calibration marks when setting period time, the period must be converted to frequency.

Example: Set generator for a 23 μ s pulse period.

1. Find the number 23 (or .23, 2.3, etc.) in the Time column. Note its form and Freq equivalent.

Time	Freq
2.3	.44

2. Express 23 μ s using the 2.3 form: 2.3×10^{-5} .
3. Set FREQ/PERIOD MULT switch to the equivalent of 10^{-5} : 10 μ .

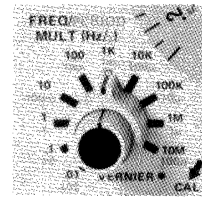

4. Set the dial to the frequency equivalent of 2.3: .44.

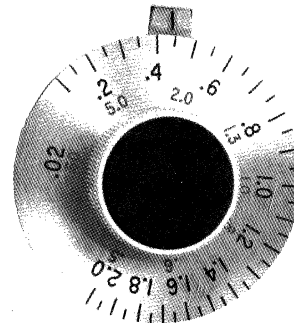

NOTE: Refer to paragraph 1.2 for dial accuracy.

TRIGGER LEVEL Control

Determines the level at which the input trigger signal at the TRIG IN connector (15) is accepted as a trigger or gate in the trigger and gate modes. The trigger level can be varied from fully cw, where a positive-going excursion thru approximately -10V is a trigger, to fully ccw, where a positive-going excursion thru approximately +10V level is a trigger.

(4) MANUAL TRIGGER Switch

Triggers or gates the output signal when GENERATOR MODE switch (3) is at TRIG or GATE. In trigger mode, one cycle is output when the switch is pressed. In gate mode, cycles are continuously output as long as the switch is held down.

NOTE

Set TRIGGER LEVEL (3) fully ccw.

(5) PULSE DELAY Control

When NORMAL/DOUBLE/DELAYED switch (6) is at DELAYED, PULSE DELAY selects one of six time ranges for delay of pulse with respect to the undelayed signal leading edge. When (6) is at DOUBLE, PULSE DELAY selects the time between double pulse leading edges.

VARIABLE Control

Inner knob selects delay time within the range selected by the outer knob.

(6) NORMAL/DOUBLE/DELAYED Switch

Selects the pulse parameters as follows:

NORMAL – Pulse of width and frequency set by front panel switches appears at TTL, \overline{TTL} , ECL,

$\overline{\text{ECL}}$ and FUNCTION OUT connectors with synchronous leading edges to the sync pulse ⑩ trailing edge.

DOUBLE—As NORMAL plus an additional pulse in each pulse period delayed from the first pulse leading edge by time ⑤

DELAYED—As NORMAL, except the pulse leading edge is delayed from the normal pulse leading edge by time ⑤

⑦ PULSE WIDTH Control

Outer knob selects the range for the width of all pulses except sync. Has OFF and square wave detents. When in OFF position, the 145 has no PULSE OUT outputs. The square wave (\square) detent is normally used to check the 50% period point; PULSE DELAY ⑤ has no effect. For the best square wave output, set FUNCTION ⑪ to \square

VARIABLE Control

Inner knob selects pulse width within the range selected by the outer knob.

⑧ ATTENUATION Control

Outer knob reduces output voltage level of all outputs at FUNCTION OUT with increasing steps of attenuation.

VERNIER Control

Inner knob is a 20 dB vernier which controls the output within the steps of the outer knob. DC and offset voltages are not affected by this control.

⑨ FUNCTION OUT Connector

The only output for the functions other than fixed amplitude pulse. At this output the functions and pulses are controllable in amplitude and dc offset; the other outputs furnish fixed amplitude pulses only.

⑩ SYNC OUT Connector

Furnishes a TTL pulse for each cycle or period of the generator. To be used for scope or similar synchronization. Refer to paragraph 3.2.1.4 for conversion to an ECL sync pulse.

⑪ FUNCTION Switch

Selects one of eight output signals; dc, waveforms or pulses.

⑫ PULSE OUT

Four standard pulses for logic circuits as follows (PULSE WIDTH ⑦ must be other than OFF):

TTL Connector—Furnishes a transistor-transistor logic level pulse whose occurrence and duration are controllable. Levels are typically $< 0.5V$ quiescent, $> 2.0V$ active into a 50Ω termination.

$\overline{\text{TTL}}$ Connector—Same as TTL connector except active and quiescent levels are reversed.

ECL Connector—Furnishes an emitter-coupled logic level pulse with controllable occurrence and duration. Levels are typically $-1.8V$ quiescent, $-0.9V$ active into a 50Ω termination connector to -2 volts. Refer to paragraph 3.2.1.3 for ECL loading instructions.

$\overline{\text{ECL}}$ Connector—Furnishes an output like the ECL output, except active and quiescent levels are reversed.

⑬ DC OFFSET Control

Offsets the waveform or dc level at ⑨ from approximately $-15V$ to $+15V$ (open circuit; approximately $\pm 7.5V$ into 50Ω). An OFF position ensures no offset.

⑭ TRIGGER START/STOP Control

Sets the start and stop point of the selected waveform (sine or triangle only) appearing at ⑨. Usually used in the trigger mode and in combination with ⑬ to create desired waveforms. 0° CAL position ensures conventional waveforms symmetrical about 0 Vdc.

⑮ TRIG IN Connector

Accepts a 1 Vp-p to $10V$ external signal to trigger the generator. (Up to $\pm 50V$ will not damage circuitry.) Triggers on rising edge of input which crosses TRIGGER LEVEL ③ setting from negative to positive.

⑯ VCG IN Connector

Accepts 0 to $+2V$ ac or dc voltages to vary up to $1000:1$ the frequency and period of the outputs.

The upper and lower limits are defined by the maximum and minimum dial (2) settings multiplied by (17). VCG input will not drive the generator beyond the normal dial limits of a range.

(17) FREQ/PERIOD MULT Switch

The outer knob selects one of ten frequency/period multipliers for the dial (2) setting. Frequency, then period, are noted at each setting.

VERNIER Control

A fine adjustment of the frequency dial (2) setting.

Not Shown EXT DC OFFSET IN Connector (Rear Panel)

Applied voltage offsets the selected waveform linearly. Offset is 1V for each -1V applied with output connected into an open circuit. Maximum input is $\pm 7.5V$. Offset is affected by the attenuator (8).

Not Shown GCV OUT Connector (Rear Panel)

This connector gives a 0 to +2V signal proportional to the frequency of the generator within any given range. The signal can be used as the X drive for X-Y recorders.

3.2 OPERATION

Perform the initial checkout in Section 2 for the feel of the instrument. Any questions concerning individual controls and connectors may be answered in paragraph 3.1.

3.2.1 Signal Termination

3.2.1.1 FUNCTION OUT Signal

Proper signal termination, or loading, of the generator connectors is necessary for its specified operation. For example,

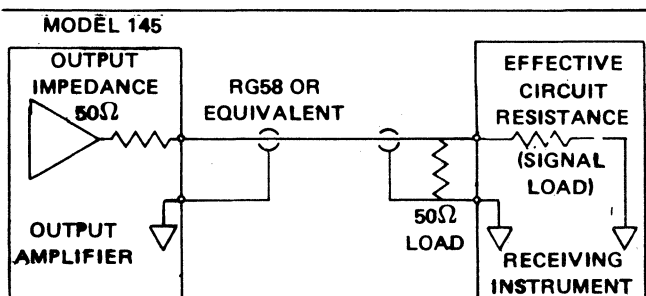

Figure 3-2. Signal Termination

the proper termination of the main output is shown in figure 3-2. Placing the 50Ω terminator, or 50Ω resistance, in parallel with a higher impedance matches the receiving instrument input impedance to the generator output impedance, thereby minimizing signal reflection or power loss on the line due to phase angle mismatch.

3.2.1.2 TTL PULSE OUT Signals

The TTL and \overline{TTL} PULSE OUT outputs can drive 50Ω and higher impedance terminations.

3.2.1.3 ECL PULSE OUT Signals

The ECL and \overline{ECL} PULSE OUT outputs are driven by MC10124's. The signals must be properly terminated at the point that they enter an external ECL circuit. Several connection possibilities are shown in figure 3-3.

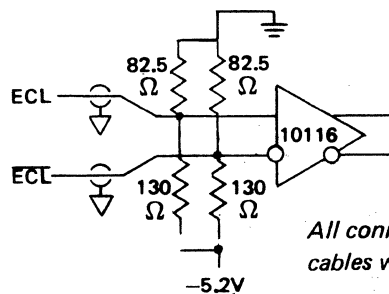
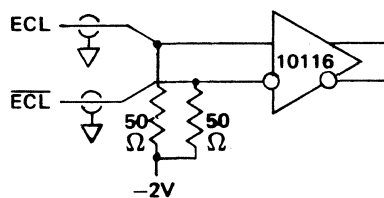
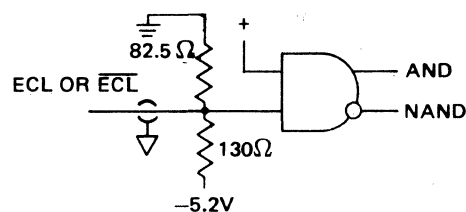
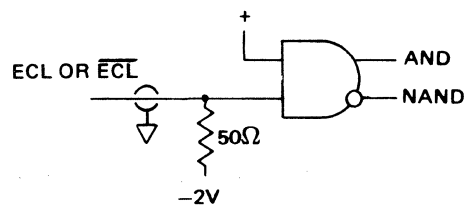

NOTE

All connecting cables are RG58 cables with BNC connectors.

Figure 3-3. ECL Terminations

3.2.1.4 Conversion of SYNC OUT TTL to ECL

The SYNC OUT TTL pulse can be converted to an ECL pulse by rerouting two jumpers on the trigger/pulse printed circuit board. Disconnect jumper at E24 and connect to E25. Disconnect jumper at E27 and connect to E28. The two jumpers are correctly routed from E25 to E26 and from E28 to E29 for ECL operation. Instrument disassembly is covered in paragraph 5.3.

3.2.2 Pulses

See figure 3-4 for definition of controllable pulse characteristics.

3.2.3 Waveforms

See figure 3-5 for definition of controllable waveform characteristics.

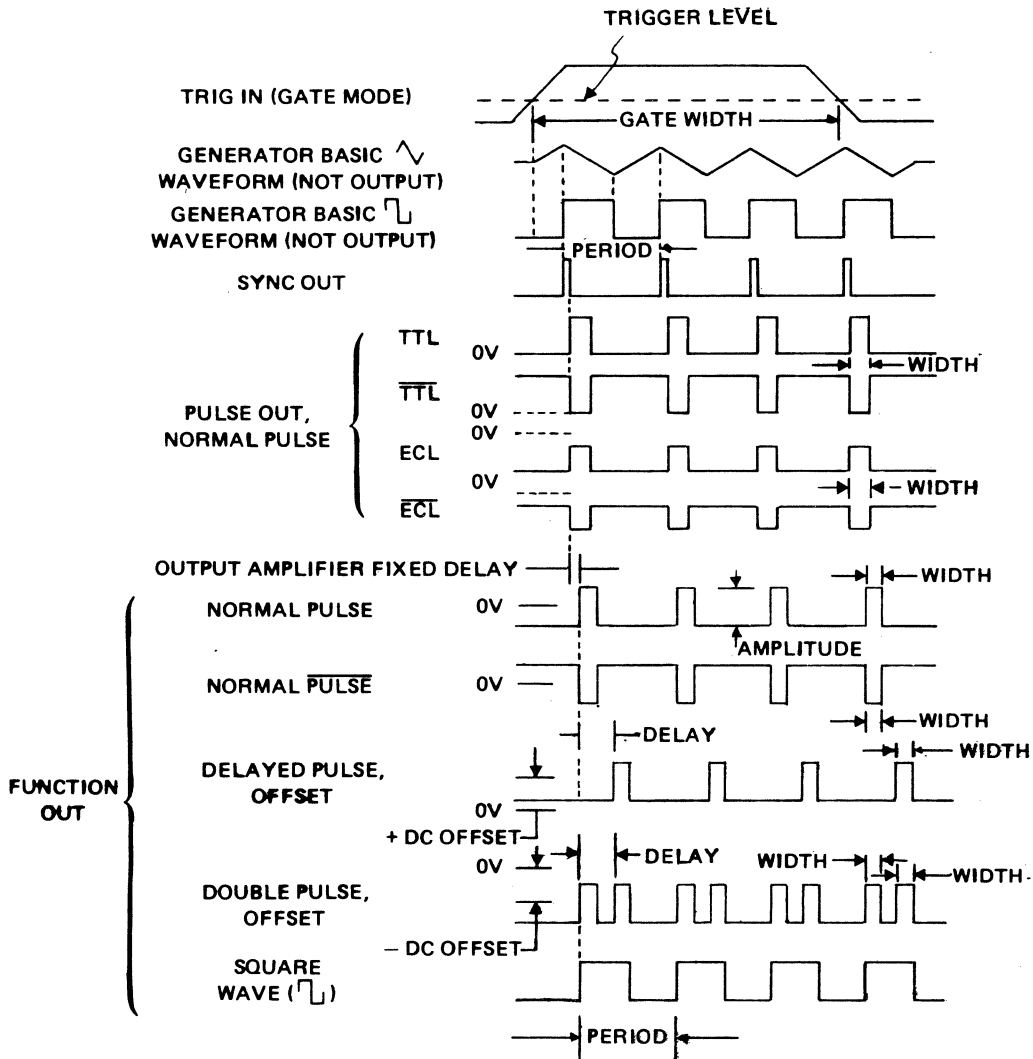

NOTES

1. Not Shown: TTL , \overline{TTL} , ECL , \overline{ECL} double pulse, delayed pulse and $\overline{\text{pulse}}$.
 2. Pulse period is determined by the generator frequency setting unless in trigger mode, in which case it is determined by trigger frequency.
 3. In trigger mode, just one period is generated for each trigger pulse.
- DC offset plus pulse peak voltage $> |7.5V|$ causes pulse clipping.

Figure 3-4. Pulse Characteristics

3.2.4 Voltage Controlled Function Generator Operation

Operation as a voltage controlled function generator (VCG) is as for a manually controlled function generator, only the frequency within particular ranges is additionally controlled with dc levels ($\pm 2V$ excursions) injected at the VCG IN connector. Set the frequency dial to a reference from which the frequency is to be voltage controlled.

1. For frequency control with positive dc inputs at VCG IN, set the dial for a lower frequency limit.
2. For frequency control with negative dc inputs at VCG IN, set the dial for an upper frequency limit.
3. For modulation with an ac input at VCG IN, set dial at desired center frequency. Do not exceed the maximum dial range of the selected frequency range.

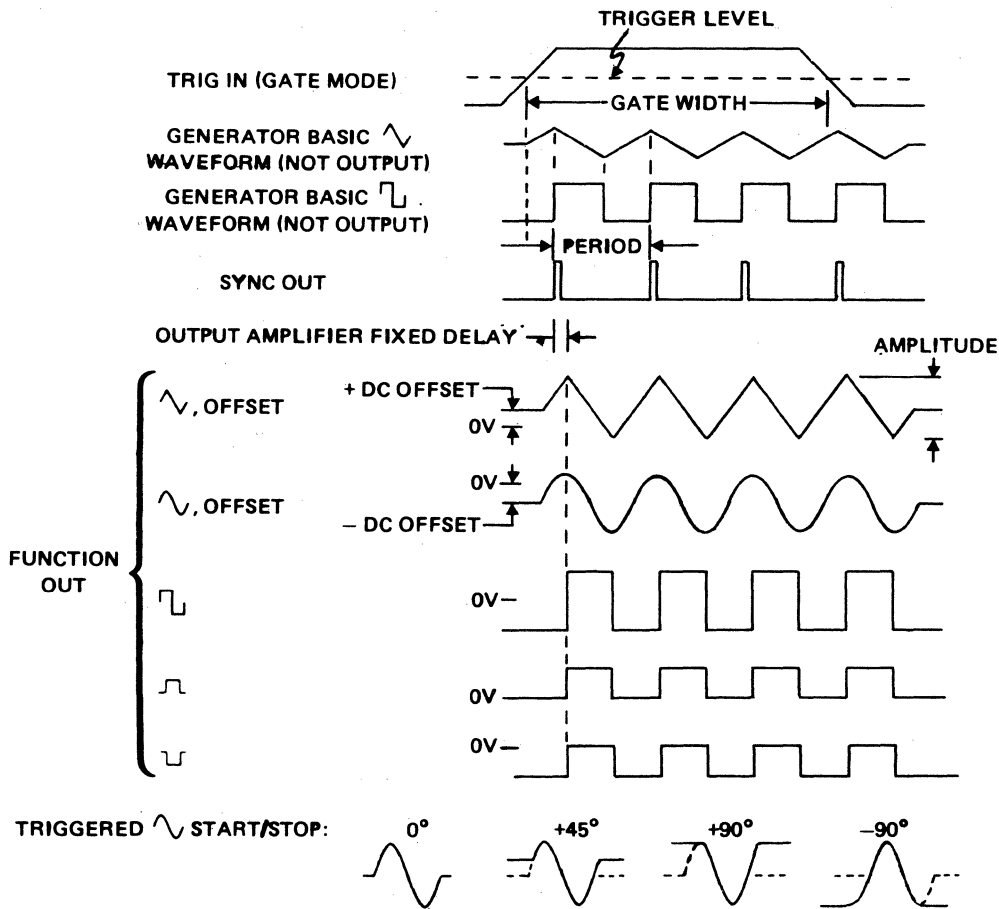

NOTES

1. Period is controlled by the generator frequency setting.
2. In trigger mode, just one period is generated for each trigger pulse.
3. DC offset plus peak waveform voltage $> |7.5V|$ causes waveform clipping.

Figure 3-5. Waveform Characteristics

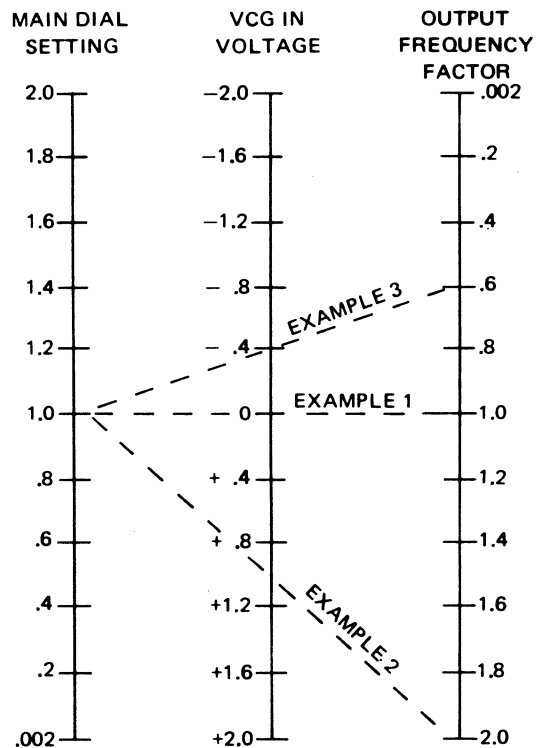

Figure 3-6. VCG Voltage-to-Frequency Nomograph

Figure 3-6 is a nomograph with examples of dial and voltage effects. Example 1 shows that with 0V VCG input, frequency is as determined by the main dial setting, 1.0 in this example. Example 2 shows that with a positive VCG input, output frequency is increased. Example 3 shows that with a negative VCG input, output frequency is decreased. (Note that the Output Frequency Factor column value must be multiplied by a frequency range multiplier to give the actual output frequency.)

NOTE

The frequency vernier must be rotated fully ccw for 1000:1 range.

Nonlinear operation results when the VCG input voltage is excessive; that is, when the attempted generator frequency exceeds the range setting (2 times the multiplier setting) or in the other direction, 1/1000th of the range setting.

The up to 1000:1 VCG sweep of the generator frequencies available in each range results from a 2V excursion at the VCG IN connector. With the frequency dial set to 2.0, excursions between -2V and 0V at VCG IN provide the up to 1000:1 frequency sweep. With the dial set to .002, excursions between 0V and +2V at VCG IN provide the up to 1000:1 sweep within the set frequency range.

3.2.5 Delay of Triggered Pulse

Additional pulse delay is available in triggered mode. Not only is the PULSE DELAY usable, but the 1/4 cycle delay between trigger acceptance and sync pulse shown in figure 3-7 can also be variable delay.

Merely determine the delay desired and apply this formula for the frequency setting:

$$\text{Frequency in Hz} = \frac{1}{(4 \cdot \text{delay in seconds})}$$

Then, adjust the pulse width for your desired pulse. Practical range with the frequency dial and multiplier is 1 ms to 42 minutes. Delay control range is 50 ns to 10 ms.

Frequency vernier and start/stop control also affect the delay. So, for accurate frequency dial control of delay, set these at their cal positions.

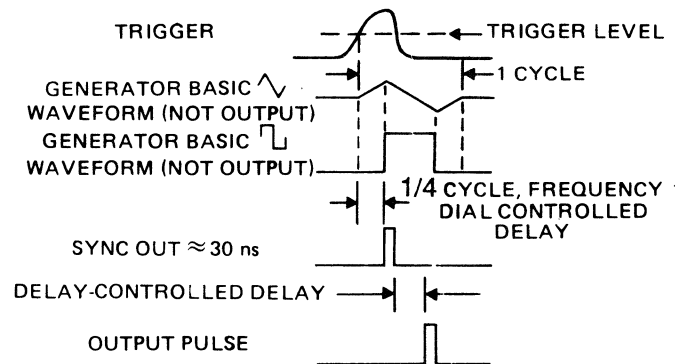

Figure 3-7. Pulse Delay From Trigger

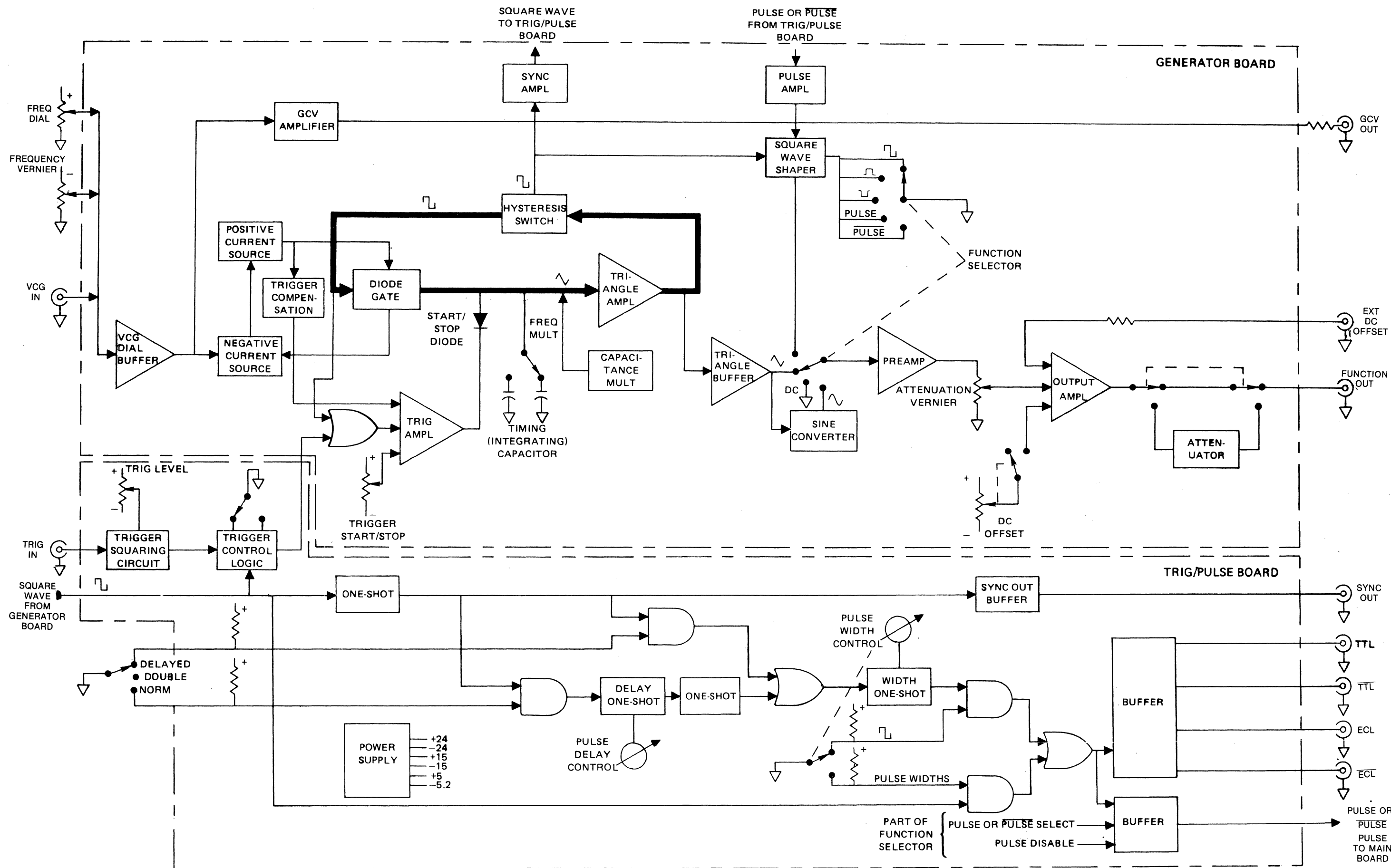

Figure 4-1. Overall Block Diagram

4

SECTION 4

CIRCUIT DESCRIPTION

4.1 BASIC WAVEFORM DEVELOPMENT

The heart of the generator (the bold path in figure 4-1) is a triangle and square wave generator. The triangle waves are developed by capacitor charging ramps that are alternately reversed in polarity. The polarity reversal is caused by a flip-flop circuit, or hysteresis switch, that in turn produces the square waves. The flip-flop changes states upon detecting amplitude limits of the charging ramps through the triangle amplifier.

As shown in figure 4-1, the VCG dial buffer sums the currents from the frequency dial, frequency vernier and VCG in connector. The VCG dial buffer is an inverting amplifier whose output voltage is used to control a positive current source and a negative current source. For symmetrical output waveforms, the currents from the two current sources are equal and directly proportional to the voltage of the VCG dial buffer output. The diode gate, which is controlled by the hysteresis switch, is used to switch the positive or the negative current to the integrating capacitor selected by the frequency multiplier. If the positive current is switched into the integrating capacitor, the voltage across the capacitor will rise linearly to generate the triangle rise transition. If the current is negative, the voltage across the integrating capacitor will fall linearly to produce the fall transition.

The triangle amplifier is a unity gain amplifier whose output is fed to the hysteresis switch. The hysteresis switch has two voltage limit points (+1.25 and -1.25V) at its input.

During the time the output voltage of the triangle amplifier is rising, the output voltage of the hysteresis switch is positive, but when the output voltage of the triangle reaches +1.25V, it triggers the hysteresis switch causing the output to switch negative. Once the control voltage into the diode gate becomes negative, it will switch the positive current out and switch the negative current in to the integrating capacitor, so that the voltage across the capacitor will reverse, starting a linear decrease of the waveform. When the decreasing voltage reaches -1.25V, the output of the hysteresis switch will switch back to positive, reversing the process. This action generates the triangle waveform as shown in figure 4-2. Since the output of the hysteresis switch is a square wave, the result is simultaneous generation of a square wave and a triangle wave at the same frequency.

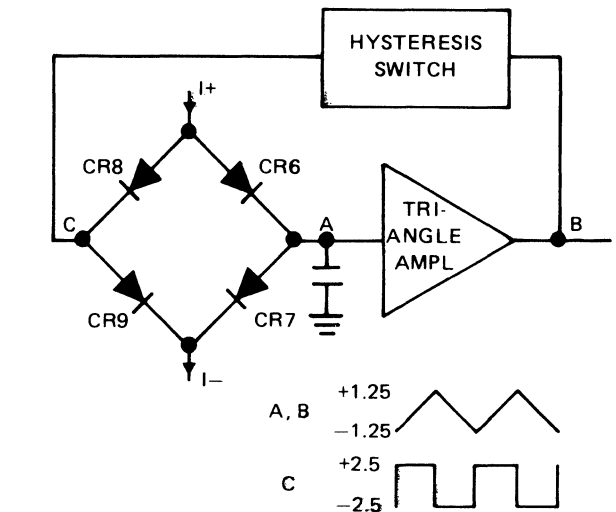

Figure 4-2. Basic Generator and Timing Diagram

The output frequency is determined by the magnitude of the capacitor selected by the frequency multiplier and the magnitude of the positive and negative current sources. Since the current sources are linearly proportional to the control voltage of the VCG circuit, the output frequency will also be linearly proportional to the control voltage.

The output of the hysteresis switch is fed to the sync amplifier and also the square wave shaper. The square wave shaper consists of a shaping circuit which limits the square wave output swing to ± 1.25 V. For positive pulse outputs, it limits the output voltage swing from -1.25 to 0V; and for negative pulse outputs, it limits the output voltage swing from 0 to +1.25V. The PULSE or PULSE from the auxiliary board are bipolar and processed as the square wave.

The triangle wave from the triangle amplifier is coupled through a buffer amplifier and made available to the function selector switch. The buffer amplifier provides a low impedance to drive the sine converter circuit. The sine converter, using the nonlinear characteristics of its diodes, converts the triangle wave into a sine wave.

The square wave from the sync amplifier, processed through a one-shot and the sync out buffer, is externally available at the sync out connector. The sync pulse, then, is a TTL level pulse output of the generator frequency.

4.2 AMPLITUDE OFFSET AND ATTENUATION

The selected waveform is inverted and amplified in the pre-amplifier. The preamplified waveform is sent to the output amplifier.

The output amplifier is an inverting amplifier with a current limiting output stage for short circuit protection. The dc offset control provides the offset to the selected waveforms center reference. The dc offset can be set by voltage at the external dc offset connector. The output amplifier establishes the generator 0 dB attenuation reference. An output attenuator decreases this reference amplitude in operator selected 20 dB steps. The attenuator consists of three voltage dividers. Attenuation between the steps is provided by the attenuation vernier.

4.3 TRIGGER AND GATE CONTROL

Generator operation is controlled by allowing or preventing the timing capacitor to charge. Figure 4-3 shows in detail this portion of the circuit. For continuous operation, the trigger amplifier maintains a positive level above the positive peak developed by the charging capacitors. This reverse biases (turns off) the start/stop diode, and the trigger amplifier does not interfere with continuous operation.

When the trigger amplifier outputs some level below the positive peak charging level, the diode is forward biased (turned on) to sink the integrating current from the current source, preventing the capacitors from charging to the positive peak. This stops waveform generation and holds the triangle output at some dc level called the trigger baseline. The trigger baseline is the level where a triangle waveform cycle starts and where it stops. This baseline is directly applicable to the triangle waveform and thus affects the sine wave. The square wave levels, output via the hysteresis switch, are not affected by the triangle baseline levels.

The normal trigger baseline is zero volts, analogous to 0° phase of a sine or triangle waveform. The trigger start/stop control offsets the trigger amplifier output and can change the baseline for starting and stopping a sine or triangle waveform from its negative peak (-90°) to its positive peak (+90°) range. At the extreme positive peak level setting though, the diode is again reverse biased and generator operation goes continuous.

When charging level is being held, the positive current generator still varies its output with corresponding frequency control inputs. These varying currents must be sunk through the diode to keep the timing capacitors from varying their charge, and thus varying the trigger baseline. The baseline compensation circuit monitors the output from the positive current generator to control the trigger amplifier and thus

control the necessary compensating current through the diode.

The trigger control logic determines that after a waveform starts, it always stops at a complete cycle and at the same phase at which it started. The trigger control logic latches the trigger amplifier for an enabling output from the time the cycle starts to when the negative peak of the last cycle is reached (just one cycle in the trigger mode). Upon reaching the negative peak, the timing capacitor continues charging positive again, but stops upon reaching the trigger baseline. A square wave from the hysteresis switch synchronizes the last negative peak time for unlatching the trigger amplifier for its trigger baseline output.

The generator mode control circuitry (not shown) determines whether the trigger control logic is to be fired for just one cycle, or is to be held on for the duration of the trigger input. When in gate mode, the trigger is directly coupled for controlling the trigger control logic. In the trigger mode, the squaring circuit output is converted by a one-shot to a narrow pulse which fires the trigger control logic.

The squaring circuit is a level detector that generates a square pulse for the duration of a trigger signal above the set trigger level. The pulse is also generated for the duration the manual trigger switch is held down in gate mode, and fires one cycle in triggered mode.

4.4 PULSE OUTPUTS

The pulse outputs are based on the square wave from the basic generator circuit (see figure 4-1); the pulse frequency is controlled by the frequency dial, frequency vernier and VCG voltage in the same manner as the waveforms. The square wave is first modified to the sync pulse by a one-shot circuit; then the normal/double/delayed pulse selector switch sets or inhibits AND gates to distribute the sync pulse to the delay one-shot and the width one-shot circuits. When the switch is in normal position, the sync pulse is gated to the width one-shot; the delay one-shot is bypassed. When the switch is in delayed position, the sync pulse is gated to the delay one-shot only. With the switch in the double position, the sync pulse is gated to both the delay and width one-shots.

Pulse width of the width and delay one-shot pulses can be varied by the front panel width and delay controls, respectively. The resulting pulse is gated by the selection of a pulse width value rather than the square wave (□) detent on the pulse width switch. The pulse or the basic generator square wave, as selected by the pulse width control, is sent to a buffer circuit and output as TTL, $\overline{\text{TTL}}$, ECL and $\overline{\text{ECL}}$ pulses. The pulse or square wave is also routed to another buffer which is set by the selection of PULSE, $\overline{\text{PULSE}}$ or a

waveform with the front panel function switch. This output, a normal pulse or a complemented pulse, is routed to the square wave shaper and output, if selected, through the **output amplifier** as a variable amplitude pulse. The pulse modes of normal, delayed and double are shown as timing diagrams in figures 4-4, 4-5 and 4-6.

4.5 WIDTH AND DELAY ONE-SHOTS

The pulse width and delay one-shots feature front panel

adjustable current sources to regulate the capacitor charge time and as a result, the one-shot pulse width. The steady state condition of the one-shot circuit is as shown in figure 4-7: Upon triggering, \bar{Q} goes low, the switch transistor switches off and the capacitor begins to charge. When the voltage across the capacitor is sufficient, the level detector senses the set level, the flip-flop is cleared and the circuit reverts to its steady state condition. The duty cycle of the one-shots is limited by the capacitor discharge time when returning to steady state conditions.

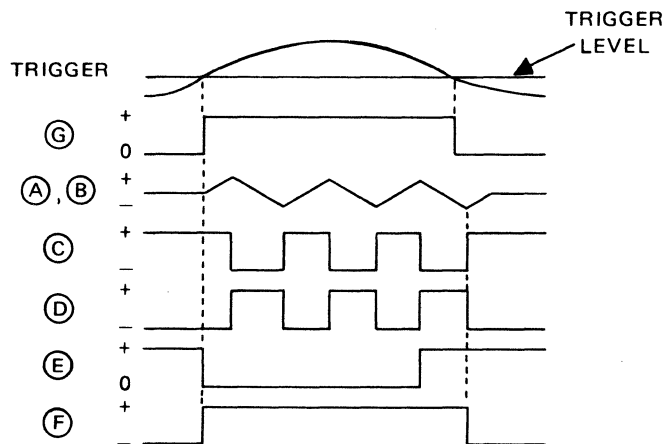
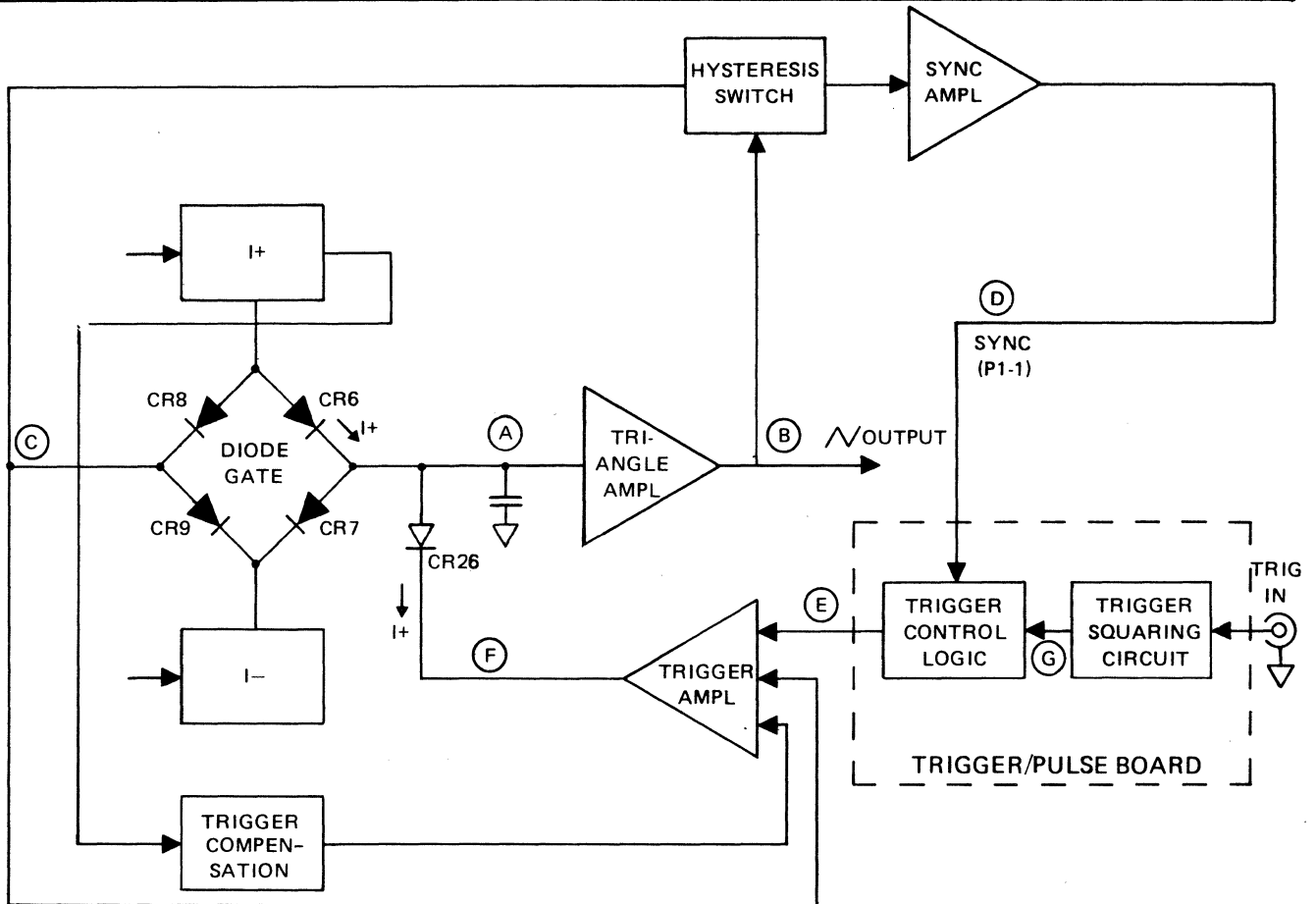

Figure 4-3. Trigger Circuit and Timing

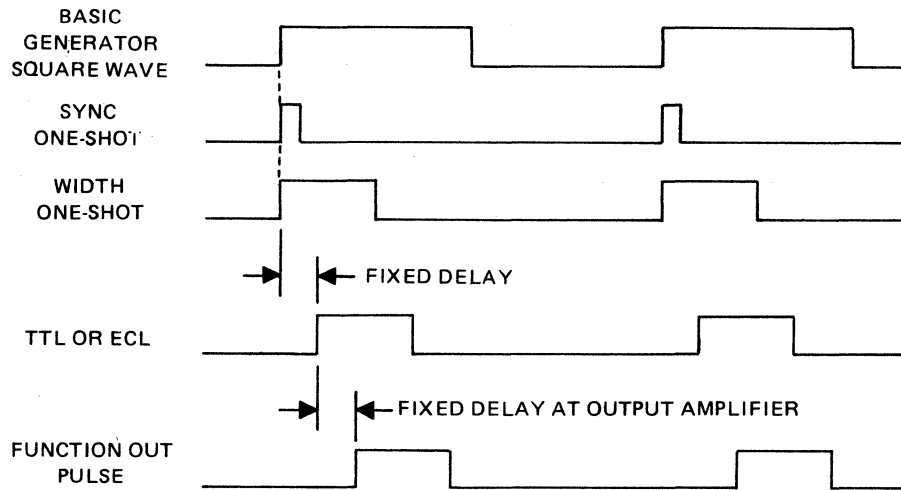

Figure 4-4. Normal Mode Timing

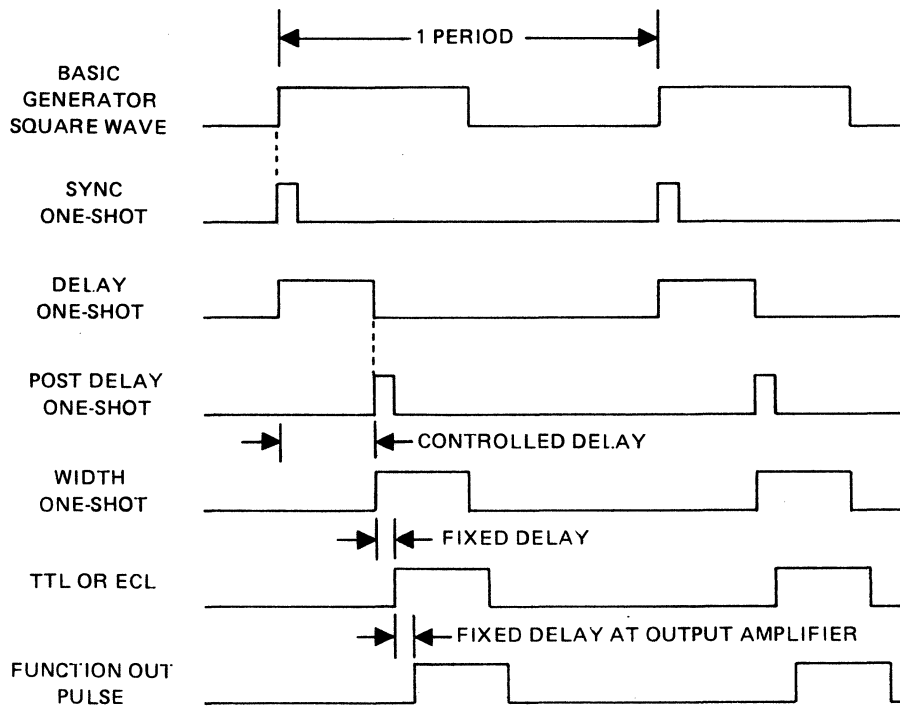

Figure 4-5. Delayed Mode Timing

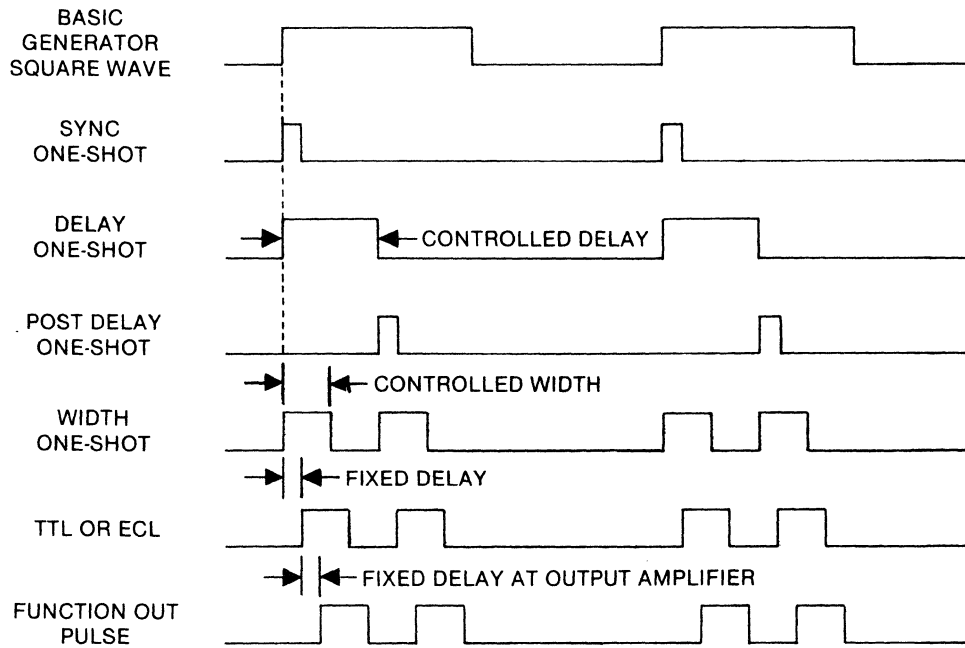

Figure 4-6. Double Mode Timing

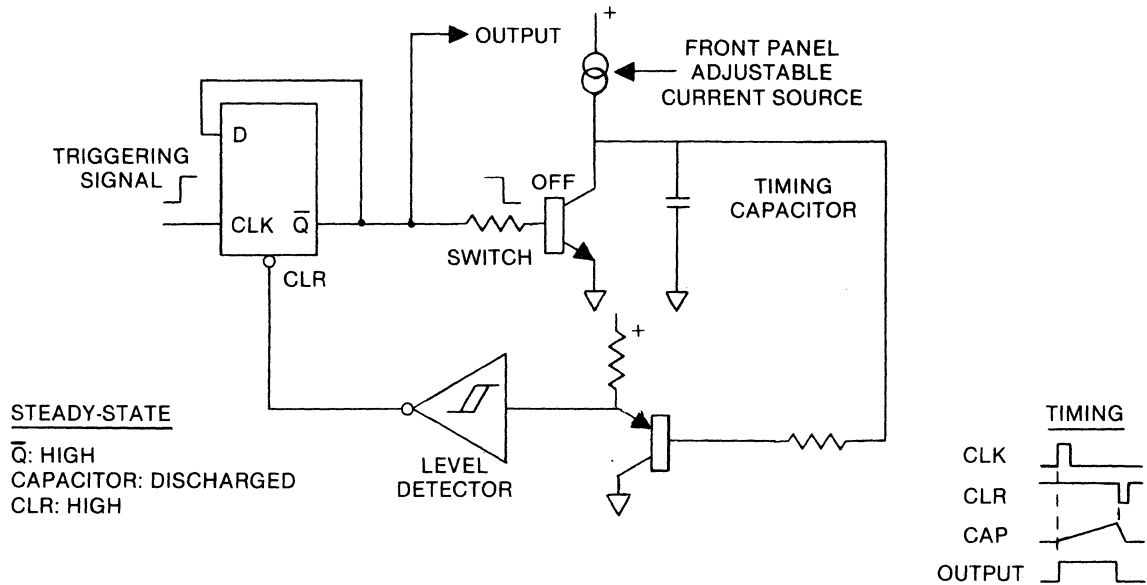

Figure 4-7. Width and Delay One-Shots

NOTE

The completion of the calibration procedure returns the instrument to correct alignment.

CALIBRATION LIMITS AND TOLERANCES ARE NOT INSTRUMENT SPECIFICATIONS

Instrument specifications are given in Section 1 of this manual.

5.1 FACTORY REPAIR

Wavetek maintains a factory repair department for those customers not possessing the necessary personnel or test equipment to maintain the instrument. If an instrument is returned to the factory for calibration or repair, a detailed description of the specific problem should be attached to minimize turnaround time.

5.2 INSPECTION AND PERFORMANCE VERIFICATION

Inspect and verify instrument performance every six months or at a frequency determined from actual instrument usage. Inspect the exterior for damage, cleanness and loose knobs. Use a soft cloth dampened with commercial window cleaner to clean the exterior. When calibrating or repairing the instrument, inspect the instrument interior for heat damage and loose wires. This instrument requires no lubrication. Verify performance by performing the calibration procedures.

5.3 REQUIRED TEST EQUIPMENT

Refer to table 1-1 for equipment required to perform the calibration procedures.

5.4 REMOVING GENERATOR COVERS

WARNING

With covers removed, several dangerous voltage points may be exposed. Contact with these points could cause serious injury or death.

1. Invert the instrument; remove the four screws in the cover.
2. Turn the instrument upright; remove the top cover; and remove the four screws securing the bottom cover.
3. Replace the top cover.

NOTE

Remove the covers only when it is necessary to make adjustments or measurements.

5.5 CALIBRATION

After referring to the following preliminary data, perform calibration, as necessary, per table 5-1. If performing partial

calibration, check previous settings and adjustments for applicability. See figures 5-1 and 5-2 for calibration point location.

1. Unless otherwise noted, all measurements made at the 50Ω OUT connector should be terminated into a 50Ω (±0.1%) load.
2. Allow the unit to warm up at least 30 minutes for final calibration. Keep the instrument covers on to maintain heat. Remove covers only to make adjustments or measurements.
3. Verify operation in TRIG and GATE modes by connecting an external generator to the TRIG IN BNC and observing proper operation of TRIGGER LEVEL and TRIGGER START/STOP controls (paragraph 3.1).
4. Verify SYNC OUT is an approximate 30 ns positive pulse into 50Ω and that GCV OUT is a voltage proportional to dial position with a 2V max (open circuit).
5. Properly terminate the TTL, \overline{TTL} , ECL and \overline{ECL} outputs (paragraph 3.2.1) and verify proper operation (paragraph 3.1)
6. After starting the calibration by connecting the unit to an ac source and setting the front panel switches as follows; invert the instrument.

Dial02
FREQ MULT	100K
FREQ VERNIER	Full cw
GENERATOR MODE	CONT
TRIGGER LEVEL	Full ccw
TRIGGER START/STOP	0° CAL
PULSE DELAY	50 ns 100 ns
PULSE DELAY VARIABLE	cw
Pulse Mode	DOUBLE
PULSE WIDTH	OFF
PULSE WIDTH VARIABLE	12 o'clock
DC OFFSET	OFF
FUNCTION	DC
ATTENUATION	20 0
ATTENUATION VERNIER	Full ccw
POWER	ON

Table 5-1. Calibration Chart

Step	Check	Tester	Cal Points	Control Settings	Adjust	Desired Results	Remarks
1	Power Supply	DVM	C112			+15 ±0.05 Vdc	If voltage is incorrect, proceed to step 3.
2			C111			-15 ±0.05 Vdc	If voltage is correct, proceed to step 9.

Steps 3 - 8 are on the trig/pulse board. Place the cover on the generator and turn it upright. Remove the top cover for access to the trig/pulse board.

3	Power Supply	DVM	TP1 (COM) TP2 (+15 Vdc)		R27	+15 ±0.02 Vdc		
4			TP3			-15 ±0.05 Vdc		
5			TP4			+24 ±1 Vdc		
6			TP5			-24 ±1 Vdc		
7			TP6			+5 ±0.2 Vdc		
8			TP7					
								R18

If steps 3 - 8 were performed, place the cover on, invert the generator and warm up the generator for ½ hour. Remove the uppermost cover for generator board access when necessary.





9	Cap Mult Balance	DVM (DCV)	TP5 (COM) TP1		R55	< 5 mV		
10	Power Ampl Balance		FUNCTION OUT		R181	0 ±0.01 Vdc		Terminate with 50Ω load.
11	Preamp Balance				ATTENUATION VERNIER: full cw	R252		
12	VCG Null	Scope	FUNCTION: 	R12	Minimum frequency shift	Observe one cycle at 50μs/div. Alternately short and open VCG IN BNC while adjusting R12.		
13	1000:1 Freq			FREQ VERNIER: full ccw	R13 BOD Freq Adj		< 1 cycle (< 200 Hz)	Scope on .5 ms/div.

Table 5-1. Calibration Chart (Continued)

Step	Check	Tester	Cal Points	Control Settings	Adjust	Desired Results	Remarks
14	1000:1 Symmetry	Scope	FUNCTION OUT		R16 BOD Sym	Symmetrical waveform	<i>NOTE: Steps 13 and 14 are interactive.</i>
15	Main Symmetry			FREQ VERNIER: full cw Dial: 2.0 FREQ MULT: 1K	R35 TOD Sym	Symmetrical waveform	
16	Sine Distortion	Distortion Analyzer, Scope		FUNCTION: 	R120 Triangle Balance	Symmetrical residue	Connect FUNCTION OUT to distortion analyzer and distortion analyzer output to scope. Set scope to .1V/div. Sync scope to SYNC OUT BNC loaded into 50Ω.
17				R93, R107 Triangle Peaks	Minimum sine distortion	If either adjustment is going near a stop, re-center both pots and return to step 15.	
18	Main Freq	Frequency Counter/Timer		FUNCTION: 	R4 TOD Freq Adj	2000 ±10 Hz	Remove SYNC OUT cable.
19	Cap Mult Freq			FREQ MULT: 10	R48	20 ±0.1 Hz	
20	X 10M Freq			FREQ MULT: 10M Dial: Vary	C40	Best frequency tracking over X 10M range	
21	X 1M Freq			FREQ MULT: 1M Dial: Vary	C34	Best frequency tracking over X 1M range	This adjustment must be made each time step 20 is done.
22	Trigger Baseline		Scope	FUNCTION:  GENERATOR MODE: TRIG Dial: Vary	R162	Minimum shift of baseline around 0 Vdc	

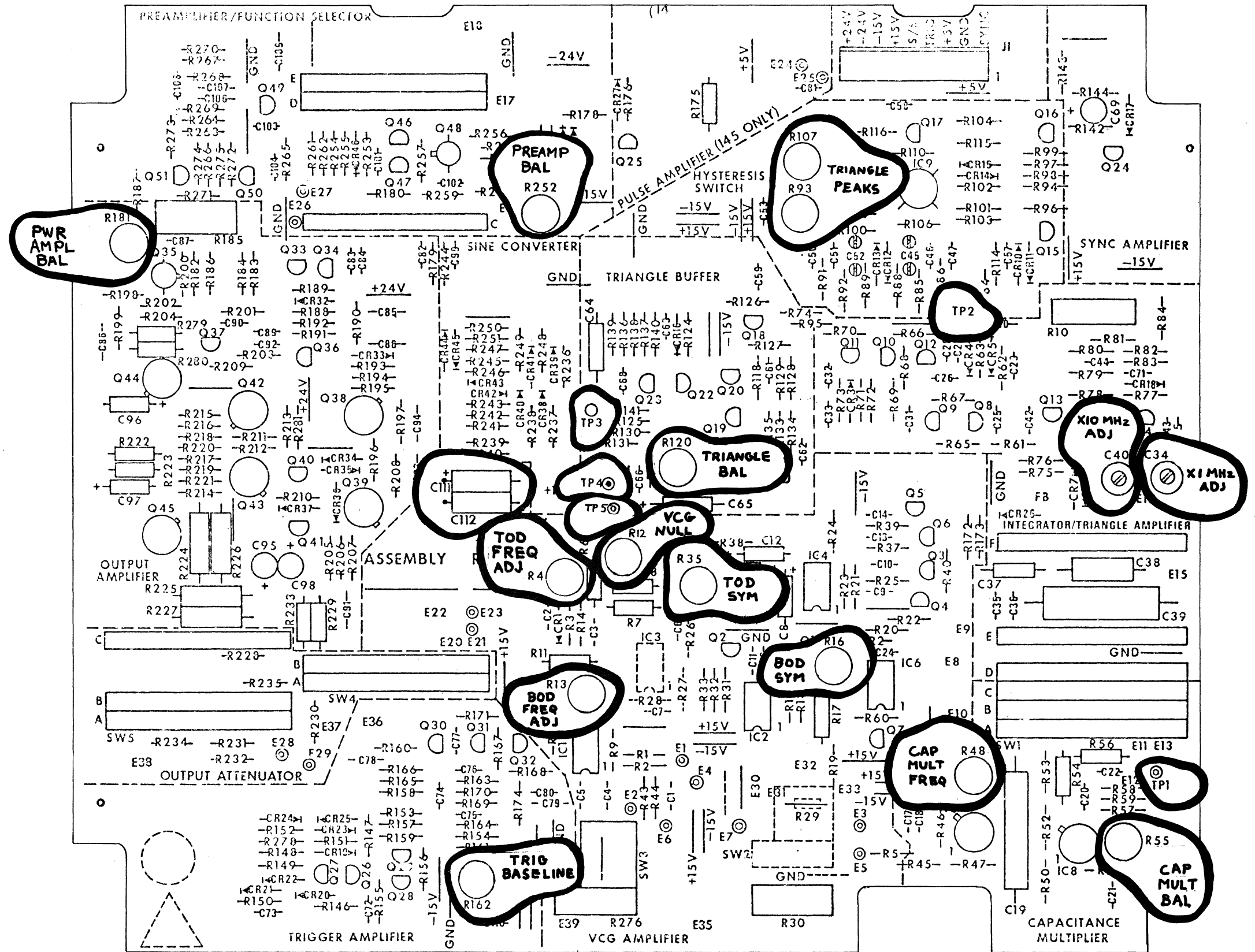

Figure 5-1. Generator Board

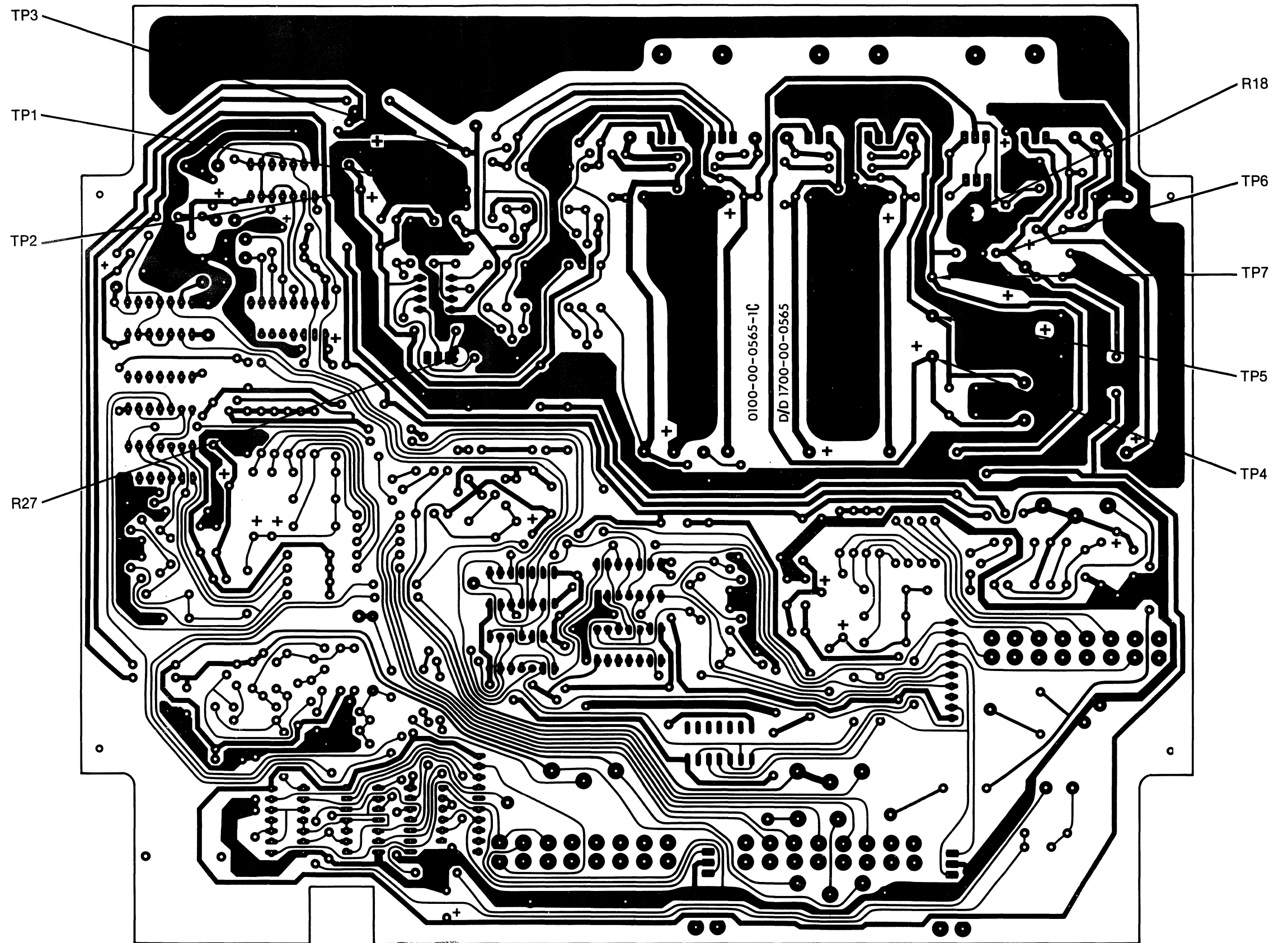

Figure 5-2. Trig/Pulse Board

SECTION 6

TROUBLESHOOTING

6.1 FACTORY REPAIR

Wavetek maintains a factory repair department for those customers not possessing the necessary personnel or test equipment to maintain the instrument. If an instrument is returned to the factory for calibration or repair, a detailed description of the specific problem should be attached to minimize turnaround time.

6.2 TROUBLESHOOTING CHARTS

Troubleshooting charts are given in figures 6-1 thru 6-9. The charts do not cover every possible trouble, but will be an aid in systematically isolating faulty components.

- Figure 6-1. Initial Checks, Generator Board
- Figure 6-2. Generator Loop Checks, Generator Board
- Figure 6-3. VCG Checks, Generator Board
- Figure 6-4. Generator Output Checks
- Figure 6-5. Trigger and Gate Mode Checks, Trig/Pulse Board
- Figure 6-6. Power Supply Checks, Trig/Pulse Board
- Figure 6-7. Generator Input and Output Checks
- Figure 6-8. Pulse Mode Checks, Trig/Pulse Board
- Figure 6-9. Pulse Generator Checks, Trig/Pulse Board

6.3 TROUBLESHOOTING INDIVIDUAL COMPONENTS

6.3.1 Transistor

1. A transistor is defective if more than one volt is measured across its base emitter junction in the forward direction.
2. A transistor when used as a switch may have a few volts reverse bias voltage across base-emitter junction.
3. If the collector and emitter voltages are the same, but the base emitter voltage is less than 500 mV forward voltage (or reversed bias), the transistor is defective.
4. A transistor is defective if its base current is larger than 10% of its emitter current (calculate currents from voltage across the base and emitter series resistors).

5. In a transistor differential pair (common emitter stages), either their base voltages are the same in normal operating condition, or the one with less forward voltage across its base emitter junction should be off (no collector current); otherwise, one of the transistors is defective.

6.3.2 Diode

1. A diode is defective if there is greater than one volt (typically 0.7 volt) forward voltage across it.

6.3.3 Operational Amplifier (e.g., 741, 1458)

1. The "+" and "-" inputs of an operational amplifier will have less than 15 mV voltage difference when operating under normal conditions.
2. When the output of the amplifier is connected to the "-" input (voltage follower connection), the output should be the same voltage as the "+" input voltage; otherwise, the operational amplifier is defective.

6.3.4 Capacitor

1. Shorted capacitors have zero volts across their terminals.
2. Opened capacitor can be located (but not always) by using a good capacitor connected in parallel with the capacitor under test and observing the resulting effect.

6.3.5 Digital TTL IC's (e.g. 7400 Series)

1. The device is operating correctly if the output high state is $> +2.4V$ and low state is $< +0.5V$.
2. The input must show the same two levels as in step 1. If the levels are between $+0.8V$ and $+2.0V$, the connection to the driving circuit output is open.

6.4 DISASSEMBLY/REASSEMBLY INSTRUCTIONS (For the Bench Instrument)

6.4.1 Disassembly

WARNING

With covers removed, several dangerous voltage points may be exposed. Contact with these points could cause serious injury or death.

Review the following procedure and identify components using chassis assembly drawing 0102-00-0575 (refer to Section 7).

1. Disconnect the power plug from the line receptacle.
2. Invert the instrument and remove four screws fastening the bottom cover to the top cover.
3. Turn the instrument upright and remove the top cover.
4. Remove the four screws fastening the lower board to the bottom cover standoffs.
5. Remove the instrument from the bottom cover and invert the instrument.
6. Unsolder the No. 18 black wire at the solder lug of FUNCTION OUT BNC.
7. Disconnect the following wires from the generator board locations:

E28 (coax) and E29 (shield) function output;
E26 (yellow) and E27 (white-black) Ext DC;
E6 (green) and E7 (white-black), GCV;
E1 (brown) and E2 (white-black), VCG;
E4 (red), E5 (brown) and E3 (orange) dial pot.
8. Remove all knobs except the dial knob.
9. Remove four screws fastening the generator board (upper board in this inverted position) to standoffs between the boards.
10. Tilt the front panel forward and slide it forward enough to clear the detents of the generator board and lift the generator board free. Slide the front panel back over the detents of the remaining board.
11. For troubleshooting, set the generator board component side up on the working surface alongside the rest of the instrument. Ensure that the generator board is lying on a nonconductive surface and it is not making physical contact with the rest of the instrument. A jumper wire may be attached between E3 and E4 of the generator

board to simulate a top-of-dial frequency voltage. It may be necessary to replace some of the knobs to set up various test conditions.

At this point, the entire instrument is accessible for troubleshooting. To reassemble, perform steps 6 through 16, paragraph 6.4.2.

12. To completely remove the generator board, disconnect the following wires from the generator board:

E21 pulse disable;
E23 pulse select;
E24 pulse coax;
E25 pulse coax shield.

Disconnect the Molex connector. To reassemble, perform steps 1 through 16, paragraph 6.4.2.
13. To remove the trigger/pulse board, remove the two screws connecting the power switch to the trigger/pulse board.
14. Unsolder the following wires from the trigger/pulse board:

E1 (blue);
E2 (white-blue);
E3 (blue);
E4 (red);
E5 (white-red);
E6 (red);
E7 (green);
E8 (green);
E9 (blue);
E10 (red);
E11 (violet);
E12 (white);
E13 (white);
E14 (white);
E15 (gray);
E16 (orange);
E17 (red);
E18 (white-black);
E19 (yellow);
E22 (brown);
E48 (green);
E30 (coax, center conductor);
E31 (coax, shield);
J6 (TTL BNC), E40 and E41;
J5 (TTL BNC), E42 and E43;
J4 (ECL BNC), E44 and E47;
J3 (ECL BNC), E45 and E46.
15. Unsolder the green-yellow wire connecting the front and rear panels.
16. Slide out the trigger/pulse board.

6.4.2 Reassembly

Refer to the chassis assembly drawing 0102-00-0575 (refer to Section 7) for correct positioning of the reassembled components.

1. Turn the unit upside down (bottom of unit up).
2. Insert the trigger/pulse board (component side up).
3. Solder the following wires to the board:
 - E1 (blue);
 - E2 (white-blue);
 - E3 (blue);
 - E4 (red);
 - E5 (white-red);
 - E6 (red);
 - E7 (green);
 - E8 (green);
 - E30 (coax-center conductor);
 - E31 (coax-shield);
 - J6 (TTL BNC), E40 and E41;
 - J5 (TTL BNC), E42 and E43;
 - J4 (ECL BNC), E44 and E47;
 - J3 (ECL BNC), E45 and E46;
 - E9 (blue);
 - E10 (red);
 - E11 (violet);
 - E12 (white);
 - E13 (white);
 - E14 (white);
 - E15 (gray);
 - E16 (orange);
 - E17 (red);
 - E18 (white-black);
 - E19 (yellow);
 - E22 (brown);
 - E48 (green).
4. Secure the power switch to the trigger/pulse board.
5. Solder the green-yellow wire connecting the front and rear panels.
6. Slide in the generator board (component side up).
7. Secure the four screws attaching the generator and trigger/pulse boards together.
8. Install the two screws securing the generator to the left side panel mounting brackets.

9. Push the front panel back over the board detents.
10. Connect the following wires to the generator board:

E4 (red), E5 (brown) and E3 (orange) dial pot;
E1 (brown) and E2 (white-black) VCG;
E6 (green) and E7 (white-black) GCV;
E28 (coax, center conductor) and E29 (coax shield);
E26 (yellow) and E27 (white-black) Ext DC;
E23 from E34 of trigger/pulse board;
E21 from E39 of trigger/pulse board;
E24 from E37 of trigger/pulse board;
E25 from E38 of trigger/pulse board.

Connect the Molex connector.

11. Solder the large No. 18 ground wire to the output BNC.
12. Turn the instrument upright and slide front and rear panels into the bottom cover. This spaces them correctly for proper knob alignment.
13. Install all knobs. Align them so that they match the front panel graphics and are spaced approximately 1/16th of an inch away from the surface the front panel.
14. Install four screws to secure the lower board to the bottom cover standoffs
15. Replace the top cover and invert the instrument.
16. Secure the top cover with four screws into bottom cover.

6.5 DISASSEMBLY/REASSEMBLY INSTRUCTIONS (For the Rack Mounted Instrument)

6.5.1 Disassembly

Review the following procedure and identify components using drawings 0102-00-0621 and 0102-00-0575 (refer to Section 7).

1. Disconnect the power plug from the line receptacle.
2. Turn the unit top side up.
3. Remove the four top cover screws and cover.

4. Invert the unit (bottom side up).
5. Remove the four bottom cover screws and cover.
6. Remove all front panel knobs except the frequency dial knob.
7. Position the unit upside down (bottom of unit) with the front panel away from you.
8. Remove the three screws holding the heat sinks of the trigger/pulse board to the rear panel.
9. Remove the two screws attaching the front panel to the right side panel (labeled "R.H." in drawing 0102-00-0621).
10. Remove the two screws securing the rear panel to the left side panel.
11. Remove the two screws securing the generator board to the left side panel mounting brackets.
12. Unsolder the large No. 18 (black) ground on the function output BNC.
13. To remove the generator board, disconnect the following wires from the generator board locations:
 - E28 (coax) and E29 (shield), function output;
 - E26 (yellow) and E27 (white-black), Ext DC;
 - E6 (green) and E7 (white-black), GCV;
 - E1 (brown) and E2 (white-black), VCG;
 - E4 (red), E5 (brown) and E3 (orange), dial pot;
 - E23 (pulse select);
 - E21 (pulse disable);
 - E24 (pulse coax);
 - E25 (pulse coax shield).

Disconnect the Molex connector.
14. Slide the rear panel to the right and backwards. Notice that the wires for the power supply are connected to the rear panel.
15. Remove the two screws attaching the generator board to the mounting brackets on the right side panel.
16. Remove the four screws securing the generator and trigger/pulse boards together.
17. Remove the main board back and upwards.

18. For troubleshooting the generator and trigger/pulse boards, turn the instrument around with the front panel facing you (keep the unit inverted). Place the generator board (component side up) on a working surface with the board on the right side of the unit. Ensure the generator board is lying on a nonconductive surface and not making physical contact with the rest of the unit. Jumper E3 and E4 simulate the top of dial frequency voltage. Pull J1 (Molex connector) from the instrument and plug into position on the generator board. Add the following jumpers between the generator and trigger/pulse board:

Trigger/Pulse	Generator
E34 (pulse select)	E23
E39 (pulse disable)	E21
E37 (pulse coax, center)	E24
E38 (pulse coax, shield)	E25

It may be necessary to replace some of the knobs to set up various test conditions.

At this point, the entire instrument is accessible for troubleshooting. To reassemble, perform steps 6 through 19, paragraph 6.5.2.

19. To remove the trigger/pulse board, remove the two screws connecting the power switch to the trigger/pulse board.
20. Unsolder the following wires from the trigger/pulse board:
 - E1 (blue);
 - E2 (white-blue);
 - E3 (blue);
 - E4 (red);
 - E5 (white-red);
 - E6 (red);
 - E7 (green);
 - E8 (green);
 - E9 (blue);
 - E10 (red);
 - E11 (violet);
 - E12 (white);
 - E13 (white);
 - E14 (white);
 - E15 (gray);
 - E16 (orange);
 - E17 (red);
 - E18 (white-black);
 - E19 (yellow);

- E22 (brown);
 - E48 (green);
 - E30 (coax, center conductor);
 - E31 (coax, shield);
 - J6 (TTL BNC), E40 and E41;
 - J5 (TTL BNC), E42 and E43;
 - J4 (ECL BNC), E44 and E47;
 - J3 (ECL BNC), E45 and E46.
21. Unsolder the green-yellow wire connecting the front and rear panels.
 22. Slide out the trigger/pulse board.

6.5.2 Reassembly

Review the following procedure and identify components using drawings 0102-00-0621 and 0102-00-0575 (refer to Section 7).

1. Turn the unit upside down (bottom of unit up).
2. Insert the trigger/pulse board (component side up).
3. Solder the following wires to the board:
4. Secure the power switch to the trigger/pulse board.

- E1 (blue);
- E2 (white-blue);
- E3 (blue);
- E4 (red);
- E5 (white-red);
- E6 (red);
- E7 (green);
- E8 (green);
- E30 (coax-center conductor);
- E31 (coax-shield);
- J6 (TTL BNC), E40 and E41;
- J5 (TTL BNC), E42 and E43;
- J4 (ECL BNC), E44 and E47;
- J3 (ECL BNC), E45 and E46;
- E9 (blue);
- E10 (red);
- E11 (violet);
- E12 (white);
- E13 (white);
- E14 (white);
- E15 (gray);
- E16 (orange);
- E17 (red);
- E18 (white-black);
- E19 (yellow);
- E22 (brown);
- E48 (green).

5. Solder the green-yellow wire connecting the front and rear panels.
6. Slide in the generator board (component side up).
7. Secure the four screws attaching the generator and trigger/pulse boards together.
8. Install the two screws securing the generator to the left side panel mounting brackets.
9. Attach all knobs to the front panel.
10. Slide the rear panel and right side panel into position. Align the wires with notched locations on the generator board.
11. Install the two screws securing the rear and left side panel.
12. Secure the front and right side panels with two screws.
13. Install the two screws securing the generator to the right side panel mounting brackets.
14. Secure the heat sink to the rear panel using three screws.
15. Connect the following wires to the generator board:
 - E4 (red), E5 (brown) and E3 (orange) dial pot;
 - E1 (brown) and E2 (white-black) VCG;
 - E6 (green) and E7 (white-black) GCV;
 - E28 (coax, center conductor) and E29 (coax shield);
 - E26 (yellow) and E27 (white-black) Ext DC;
 - E23 from E34 of trigger/pulse board;
 - E21 from E39 of trigger/pulse board;
 - E24 from E37 of trigger/pulse board;
 - E25 from E38 of trigger/pulse board;
 Connect the Molex connector.
16. Solder the large No. 18 ground wire to the output BNC.
17. Visually inspect the instrument for missing hardware and disconnected wires.
18. Attach top and bottom covers with four screws for each cover.
19. Check the unit for proper operation.

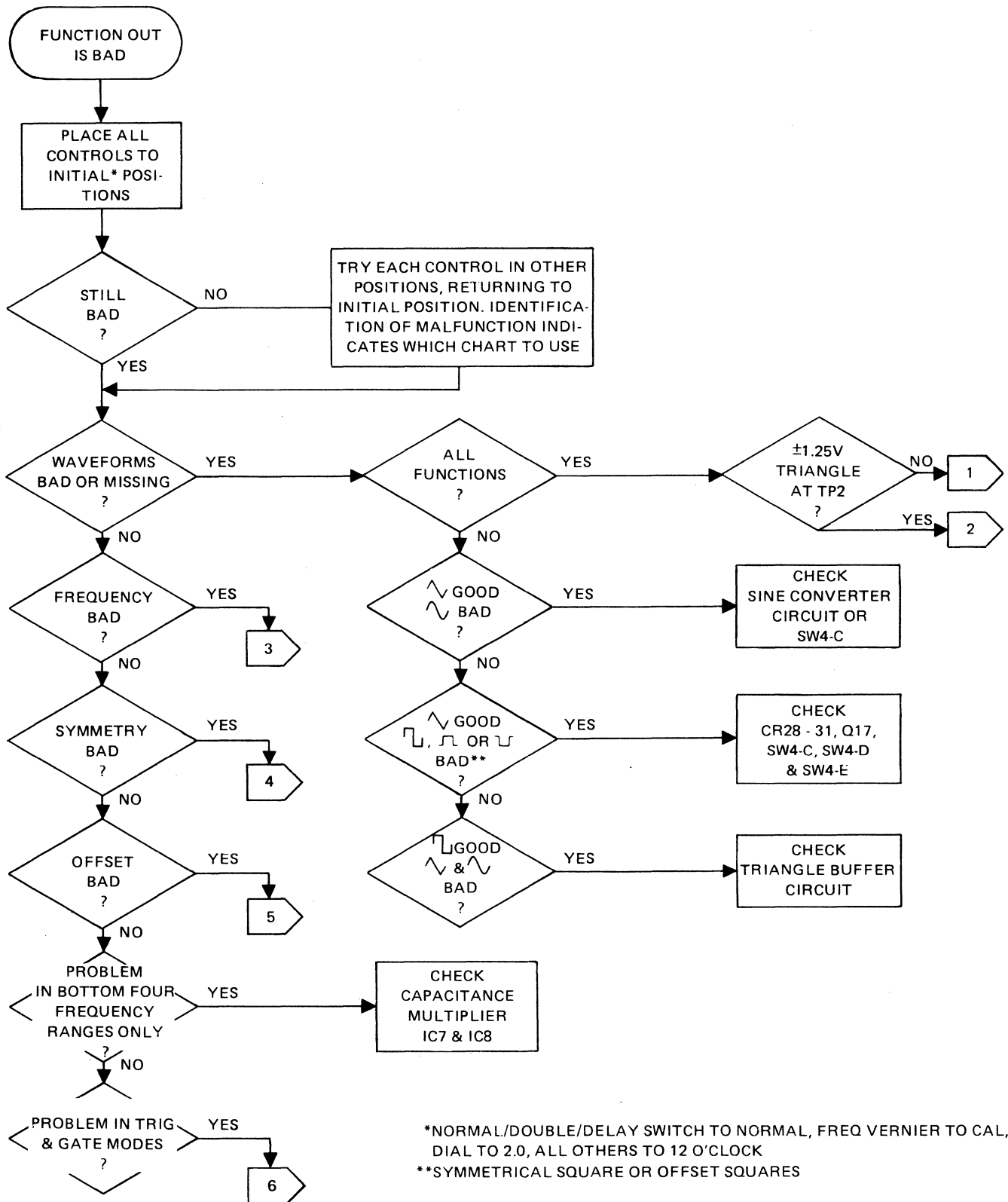
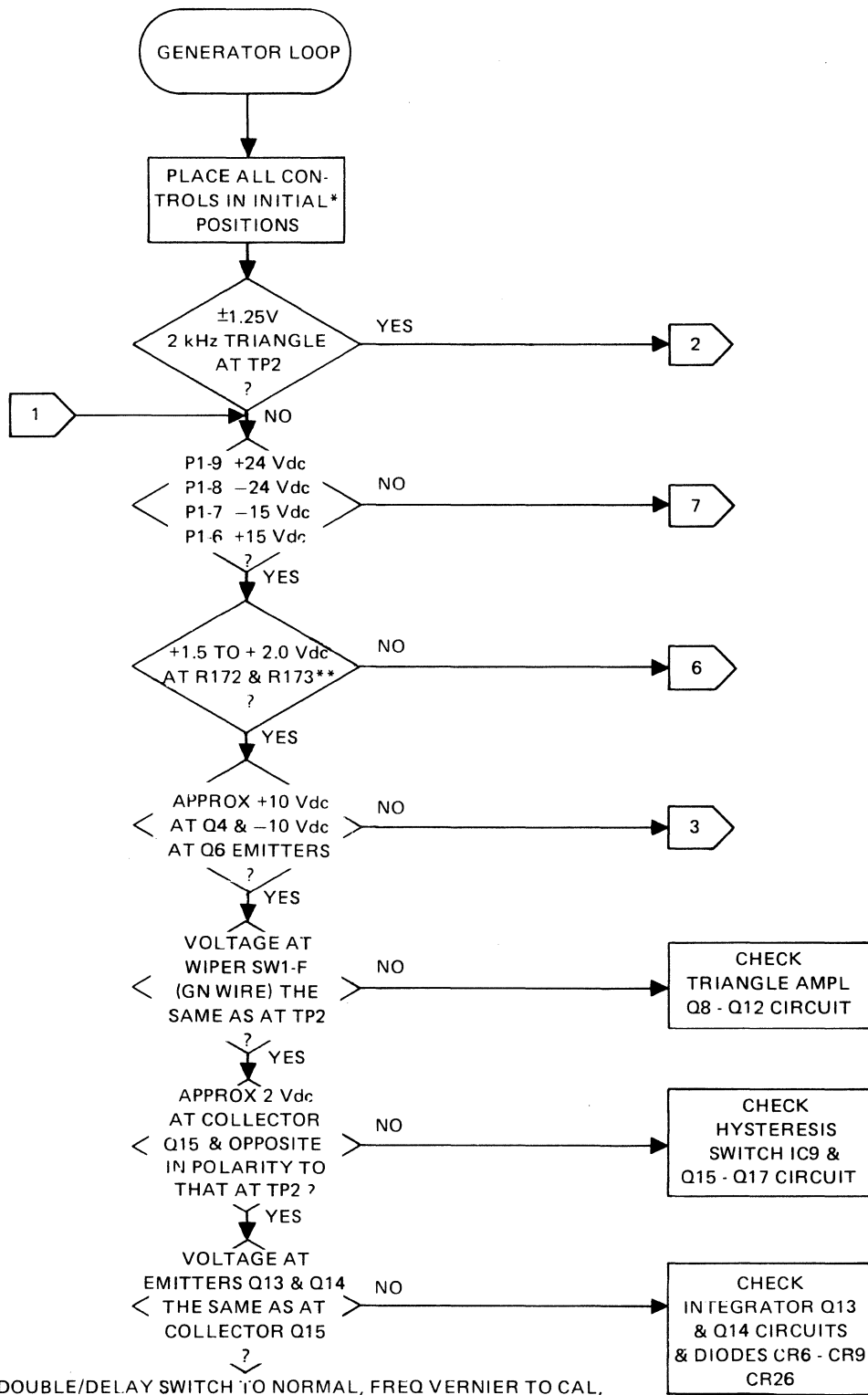

Figure 6-1. Initial Checks, Generator Board



*NORMAL/DOUBLE/DELAY SWITCH TO NORMAL, FREQ VERNIER TO CAL, DIAL TO 2.0, ALL OTHERS TO 12 O'CLOCK

**A NEGATIVE VOLTAGE HERE STOPS GENERATOR FOR TRIGGERED OPERATION

***USE SCOPE AND HIGH IMPEDANCE PROBE

Figure 6-2. Generator Loop Checks, Generator Board

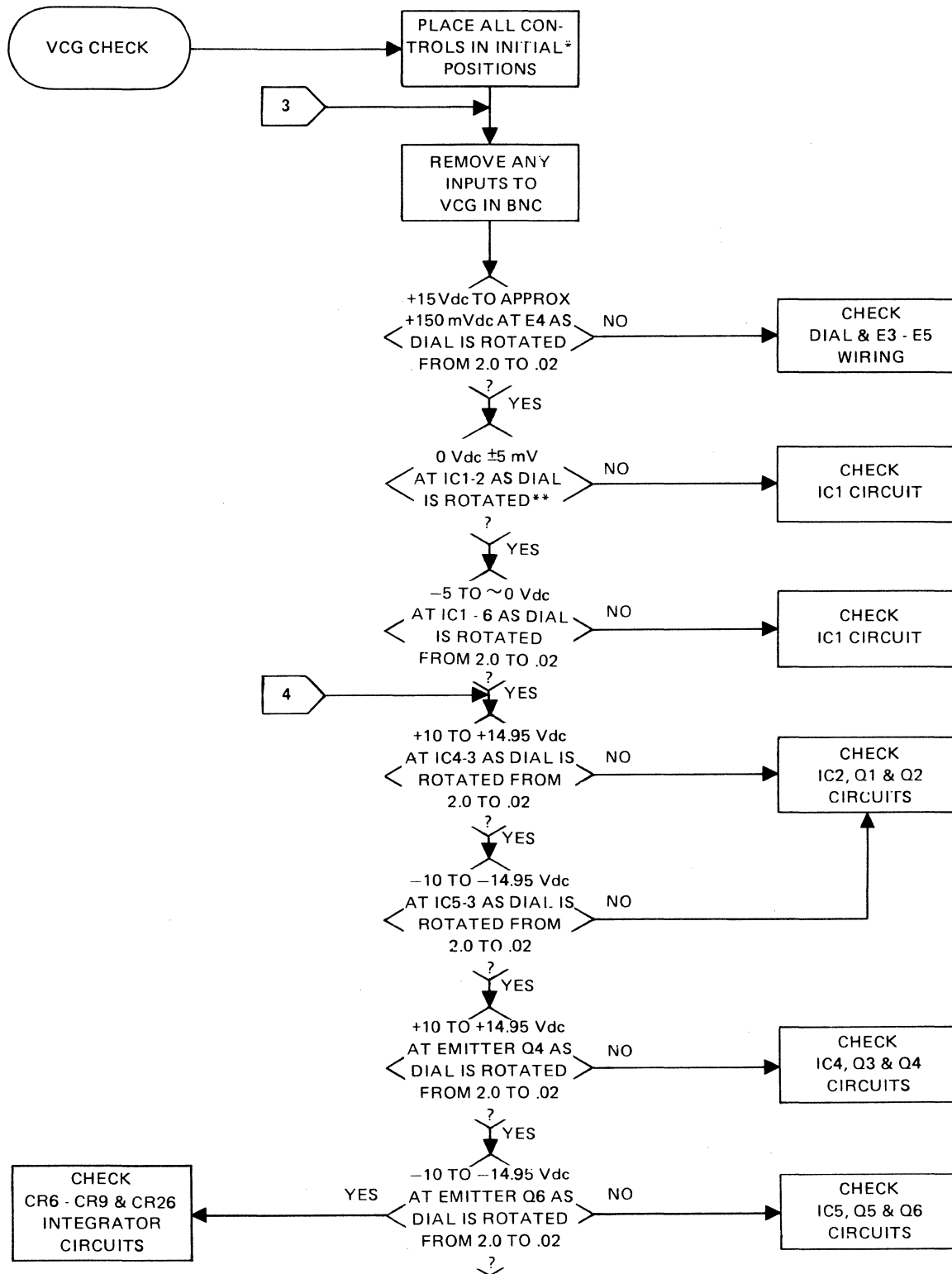

*NORMAL/DOUBLE/DELAY SWITCH TO NORMAL, FREQ VERNIER TO CAL, DIAL TO 2.0, ALL OTHERS TO 12 O'CLOCK

**USE SCOPE AND HIGH IMPEDANCE PROBE FOR THIS AND SUBSEQUENT VCG MEASUREMENTS

Figure 6-3. VCG Checks, Generator Board

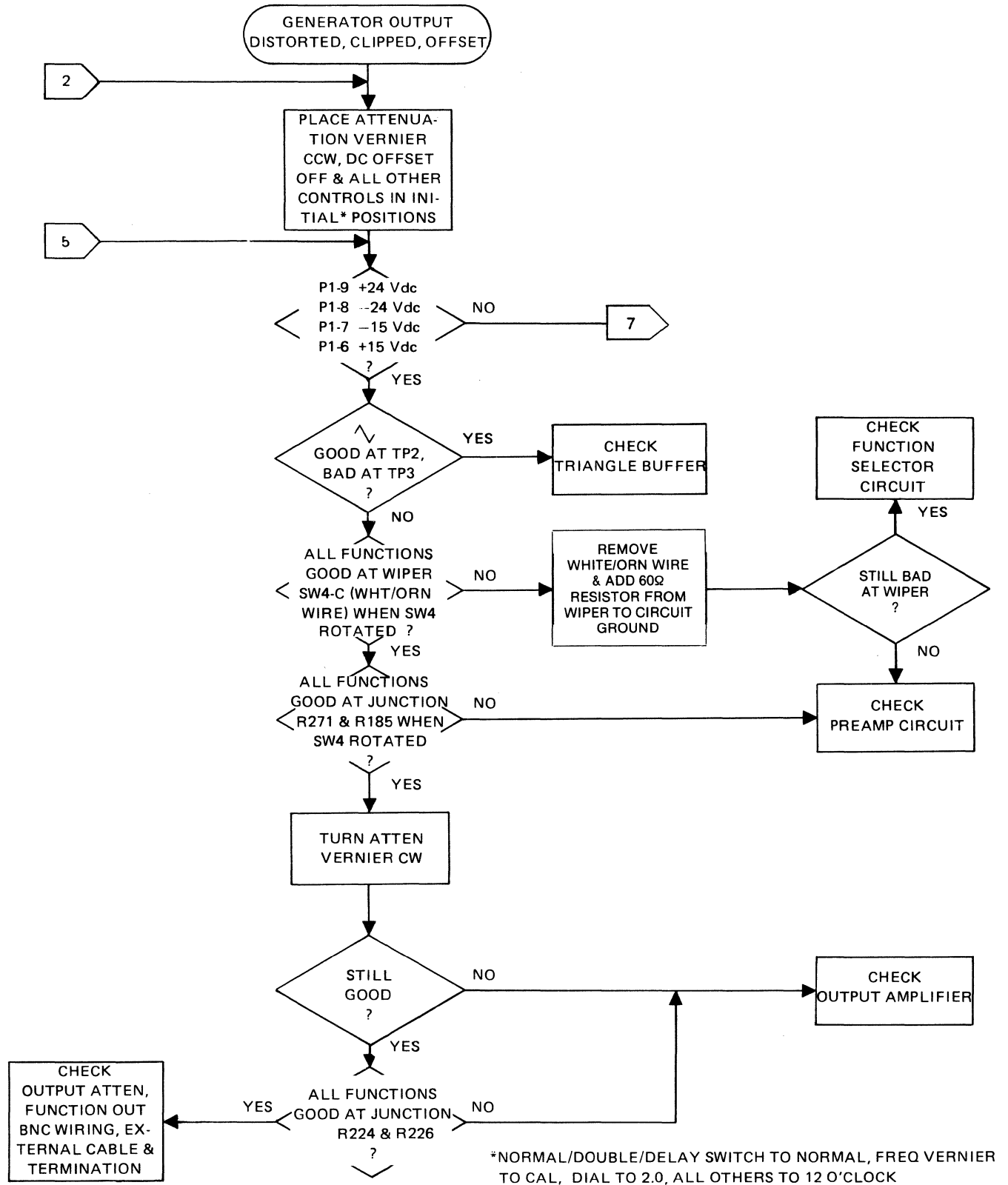
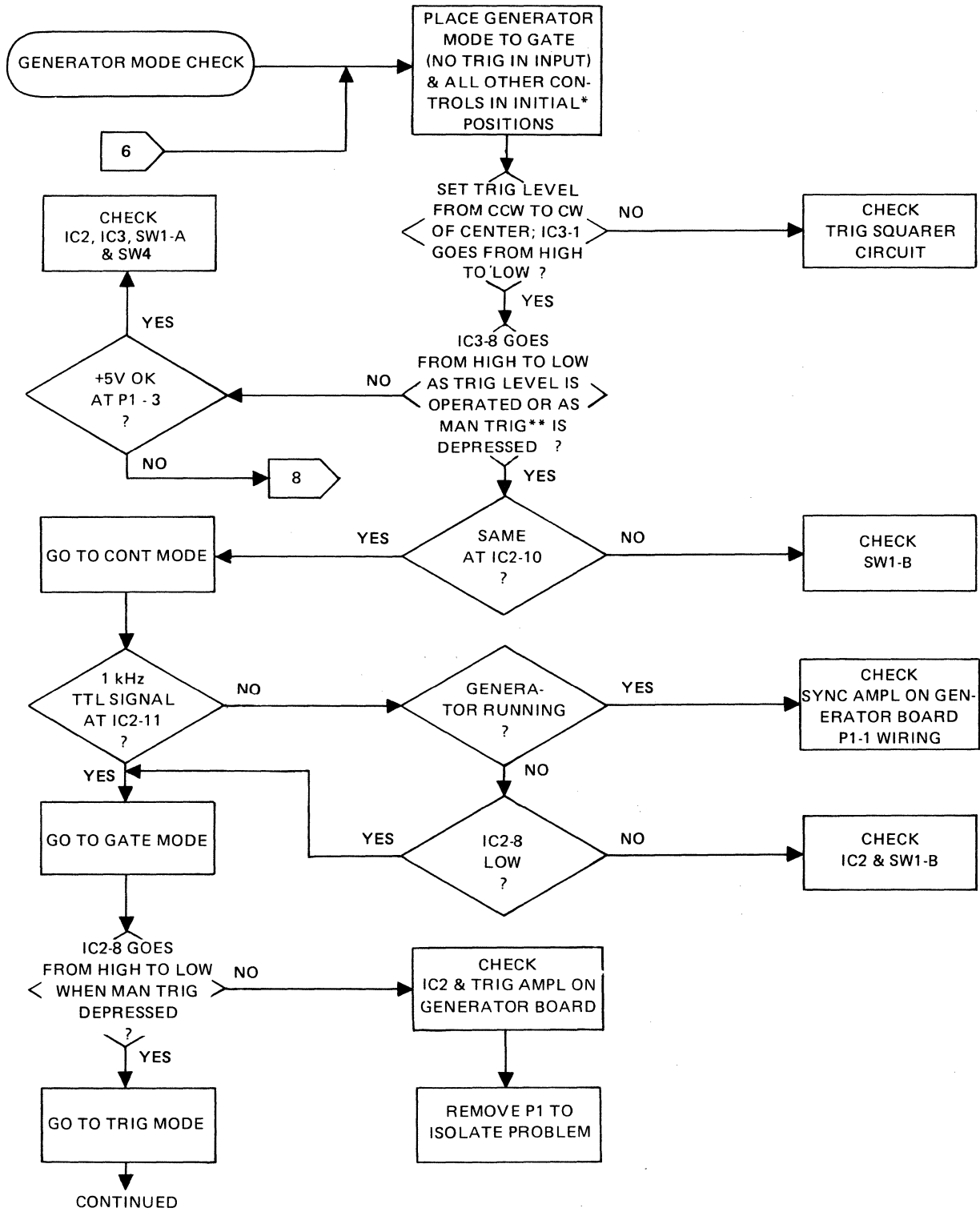

Figure 6-4. Generator Output Checks, Generator Board



*NORMAL/DOUBLE/DELAY SWITCH TO NORMAL, FREQ VERNIER TO CAL,
DIAL TO 2.0, ALL OTHERS TO 12 O'CLOCK

**RETURN TRIG LEVEL CCW TO OPERATE MANUAL TRIGGER

Figure 6-5. Trigger and Gate Mode Checks, Trig/Pulse Board (Page 1 of 2)

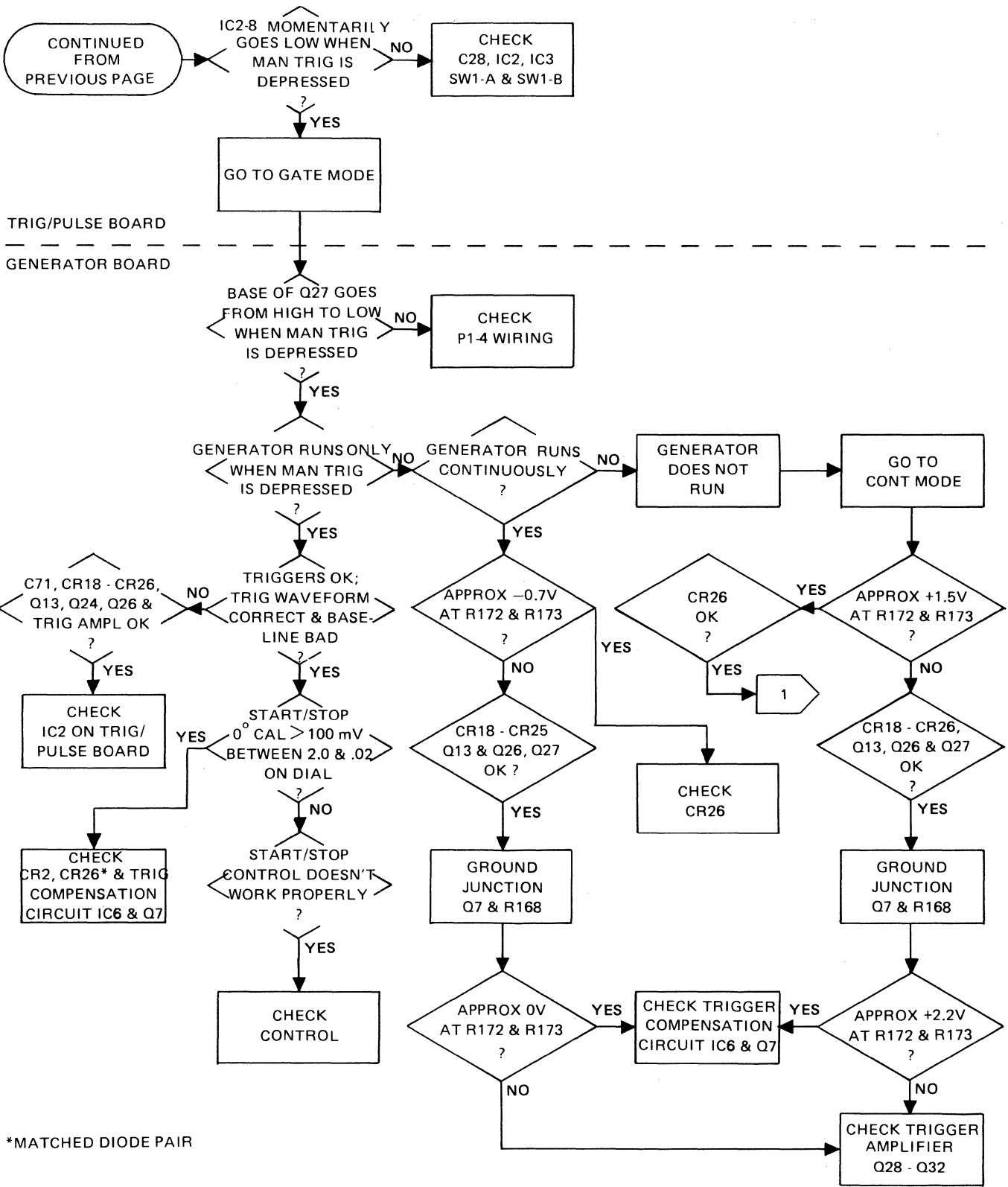

Figure 6-5. Trigger and Gate Mode Checks, Trig/Pulse Board (Page 2 of 2)

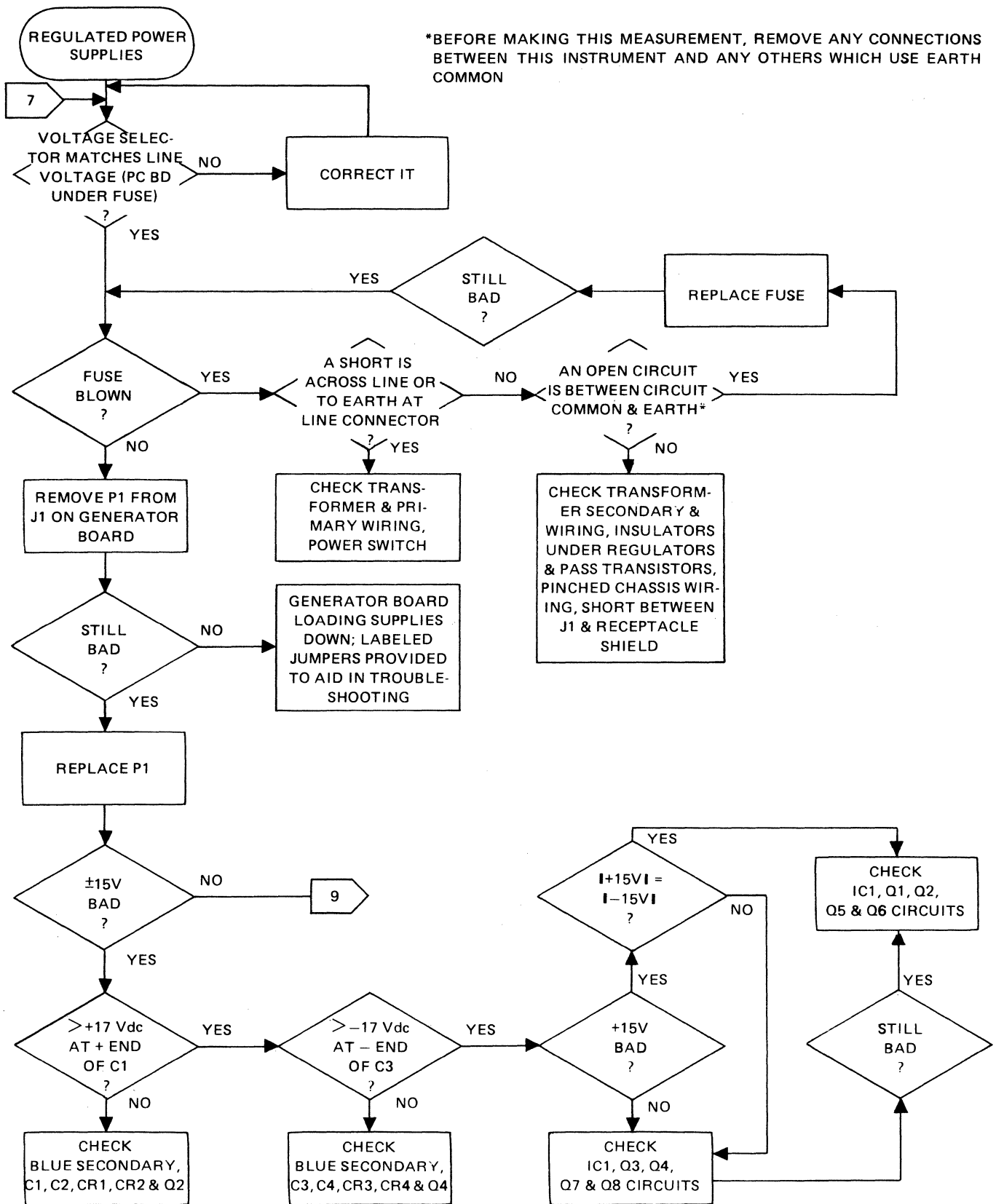

Figure 6-6. Power supply checks, Trig/Pulse Board (Page 1 of 2)

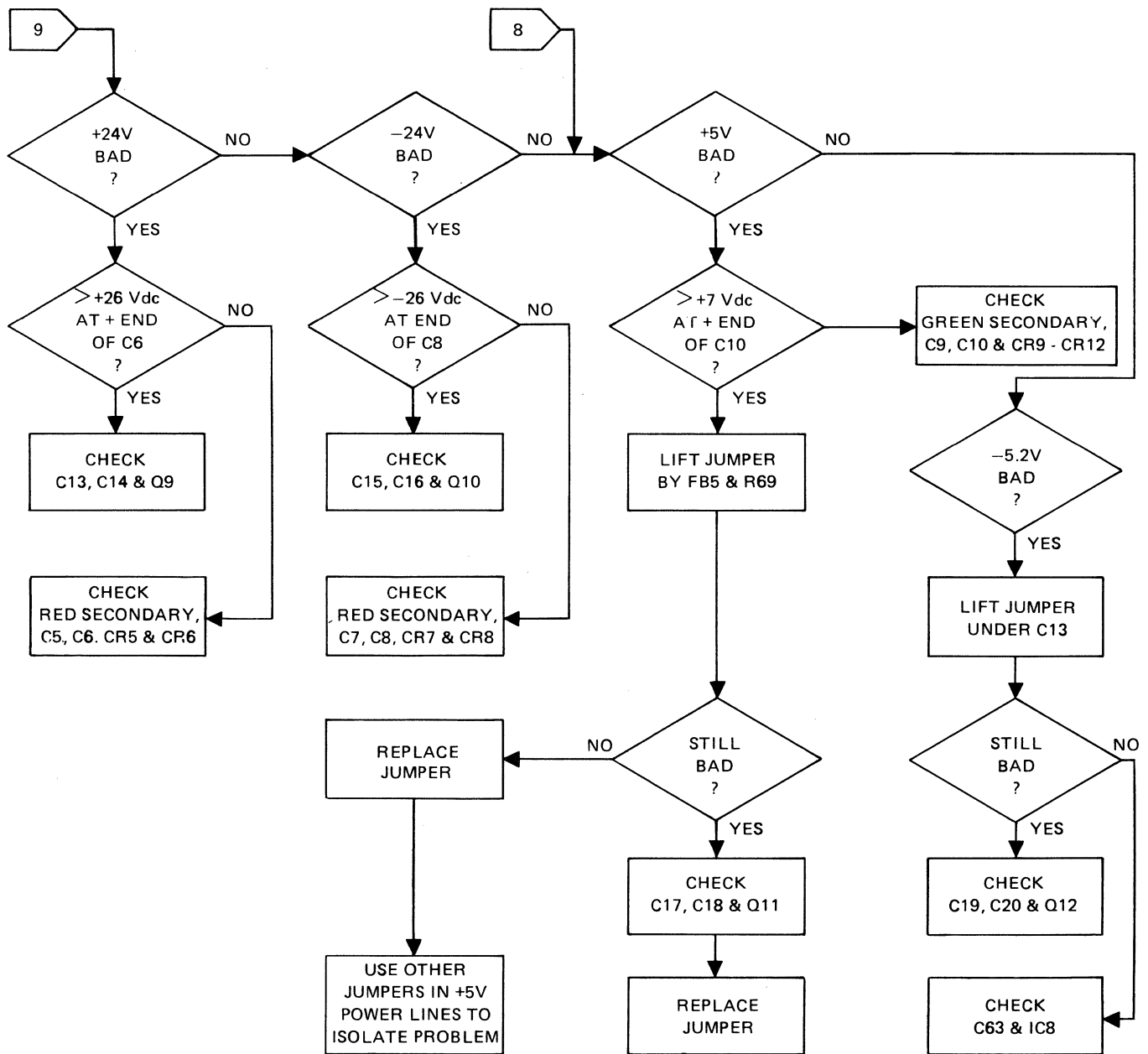

Figure 6-6. Power Supply Checks, Trig/Pulse Board (Page 2 of 2)

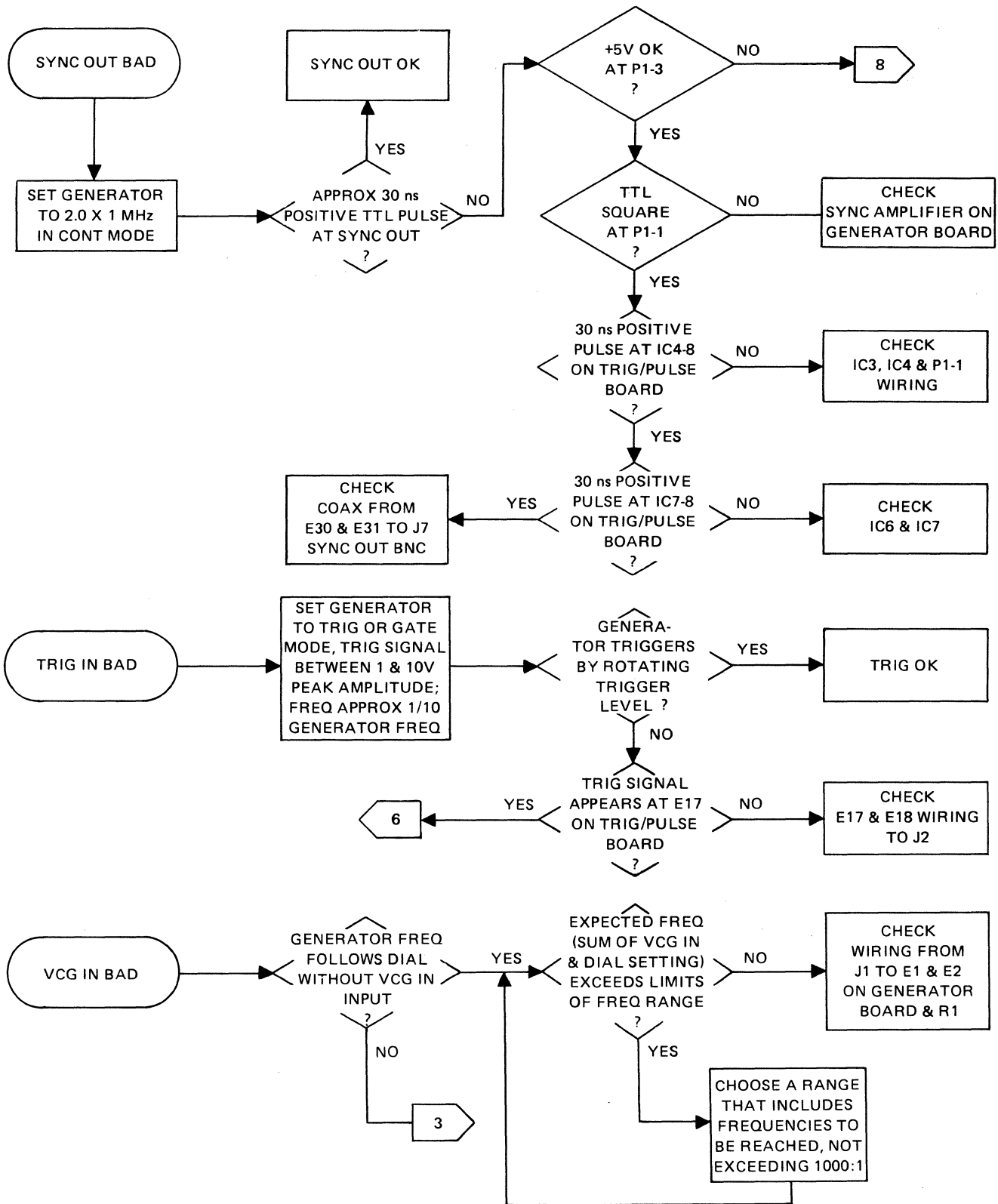

Figure 6-7. Generator Input and Output Checks (Page 1 of 2)

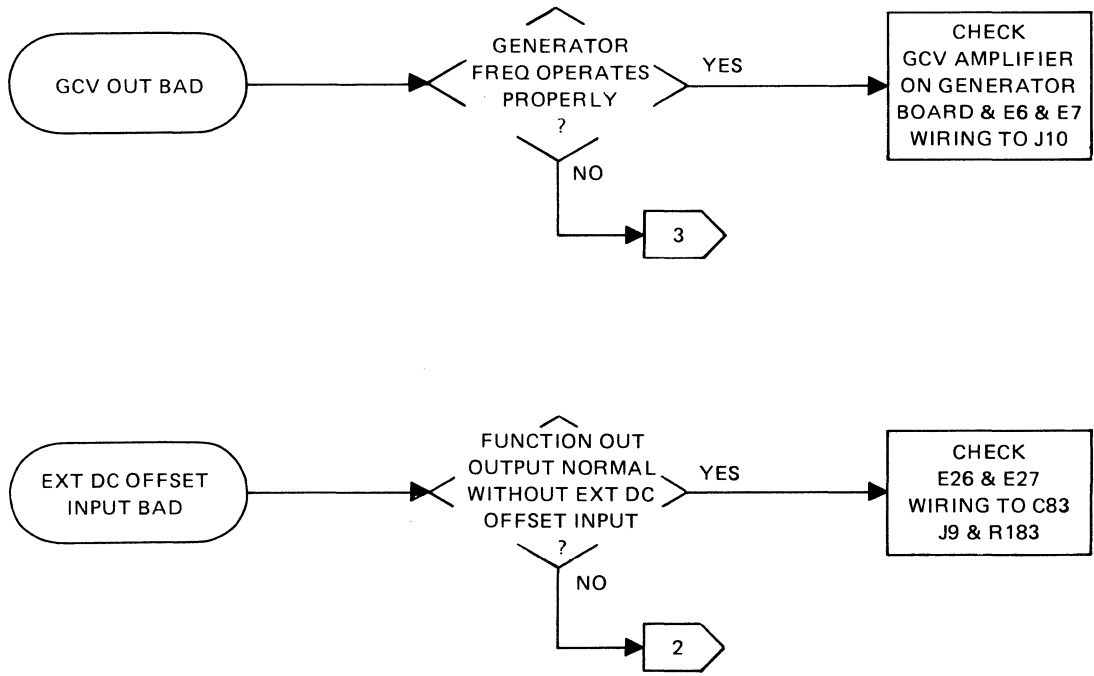
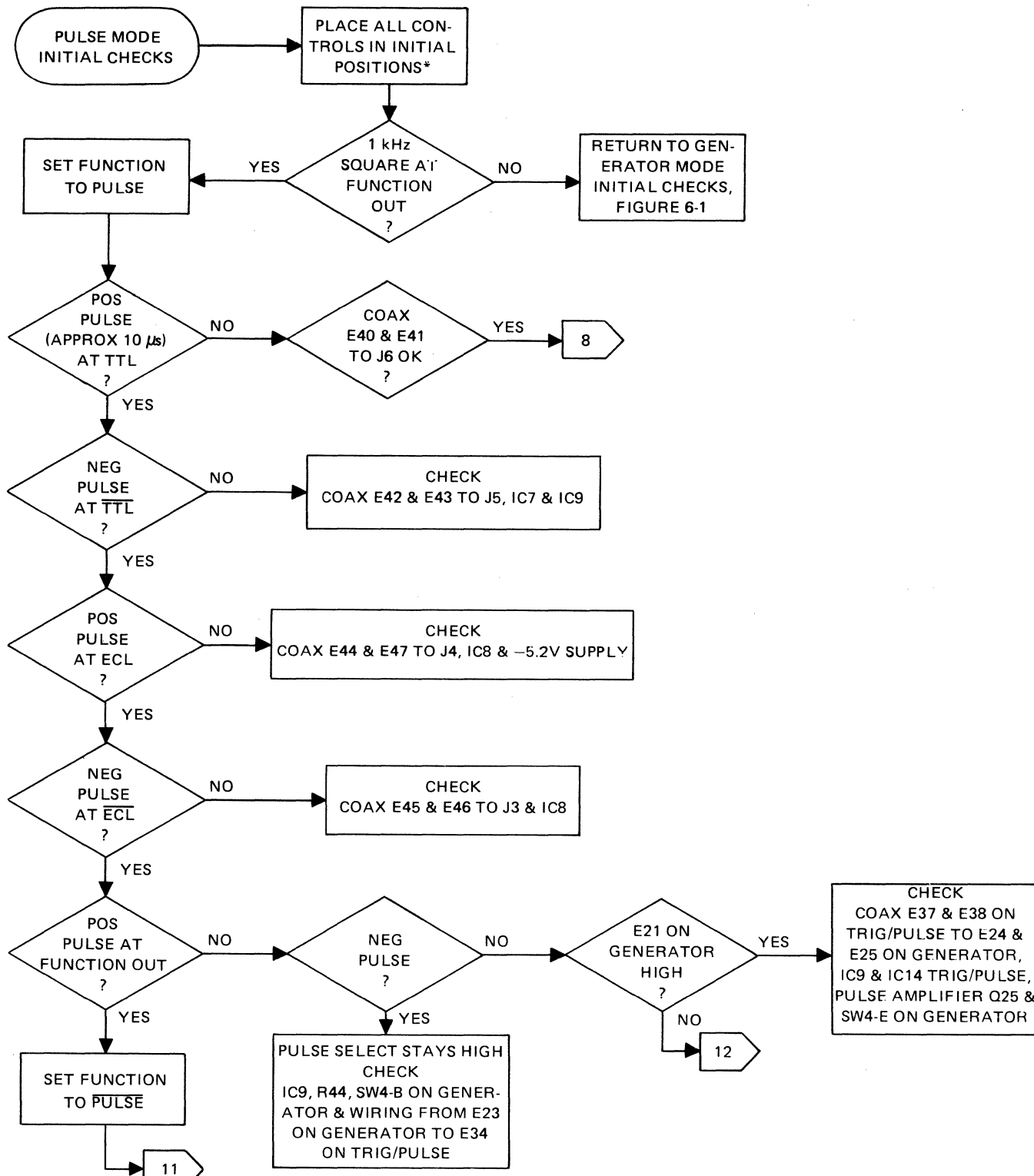

Figure 6-7. Generator Input and Output Checks (Page 2 of 2)



*NORMAL /DOUBLE/DELAY SWITCH TO NORMAL, FREQ VERNIER TO CAL, DIAL TO 2.0, ALL OTHERS TO 12 O'CLOCK

Figure 6-8. Pulse Mode Checks, Trig/Pulse board (Page 1 of 2)

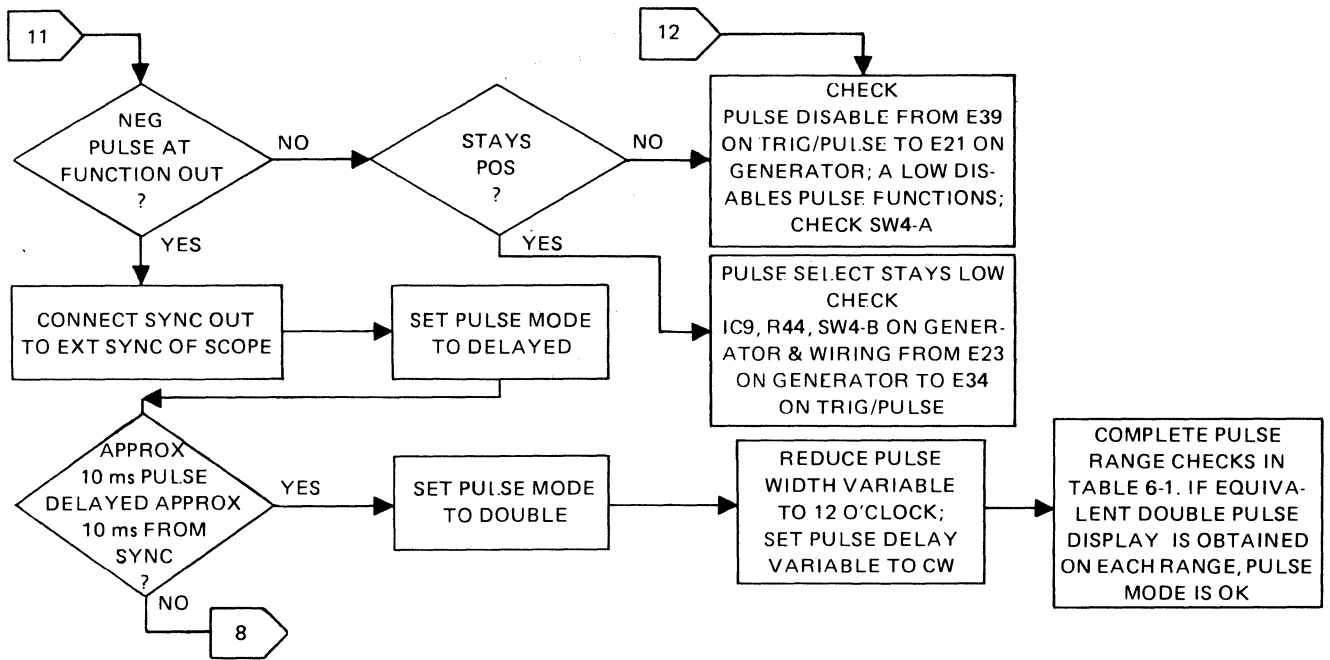

Figure 6-8. Pulse Mode Checks, Trig/Pulse Board (Page 2 of 2)

Table 6-1. Pulse Ranges

Pulse Width	Ranging Components	Pulse Delay	Ranging Components	Pulse Period	Scope Horizontal
OFF	IC5, SW3-A	NA	NA	NA	NA
25 ns 100 ns	C55, Q19, Q20, SW3-B	50 ns 100 ns	C40, Q16, Q17, SW2-B	> 0.5 μ s	0.05 μ s/div
100 ns 1 μ s	C56, CR29, CR30	100 ns 1 μ s	C41, CR19, CR20	> 5 μ s	0.5 μ s/div
1 μ s 10 μ s	C57, CR31, CR32	1 μ s 10 μ s	C42, CR21, CR22	> 50 μ s	5 μ s/div
10 μ s 100 μ s	C58, CR33, CR34	10 μ s 100 μ s	C43, CR23, CR24	> 0.5 ms	50 μ s/div
100 μ s 1 ms	C59, CR35, CR36	100 μ s 1 ms	C44, CR25, CR26	> 5 ms	0.5 ms/div
100 μ s 1 ms	C59, CR35, CR36	1 ms 10 ms†	C45, CR27, CR28	> 5 ms	0.5 ms/div
\square	IC4 - IC6, SW3-A	NA	NA	0.5 ms	0.5 ms/div

†Rotate PULSE DELAY VERNIER ccw for proper display

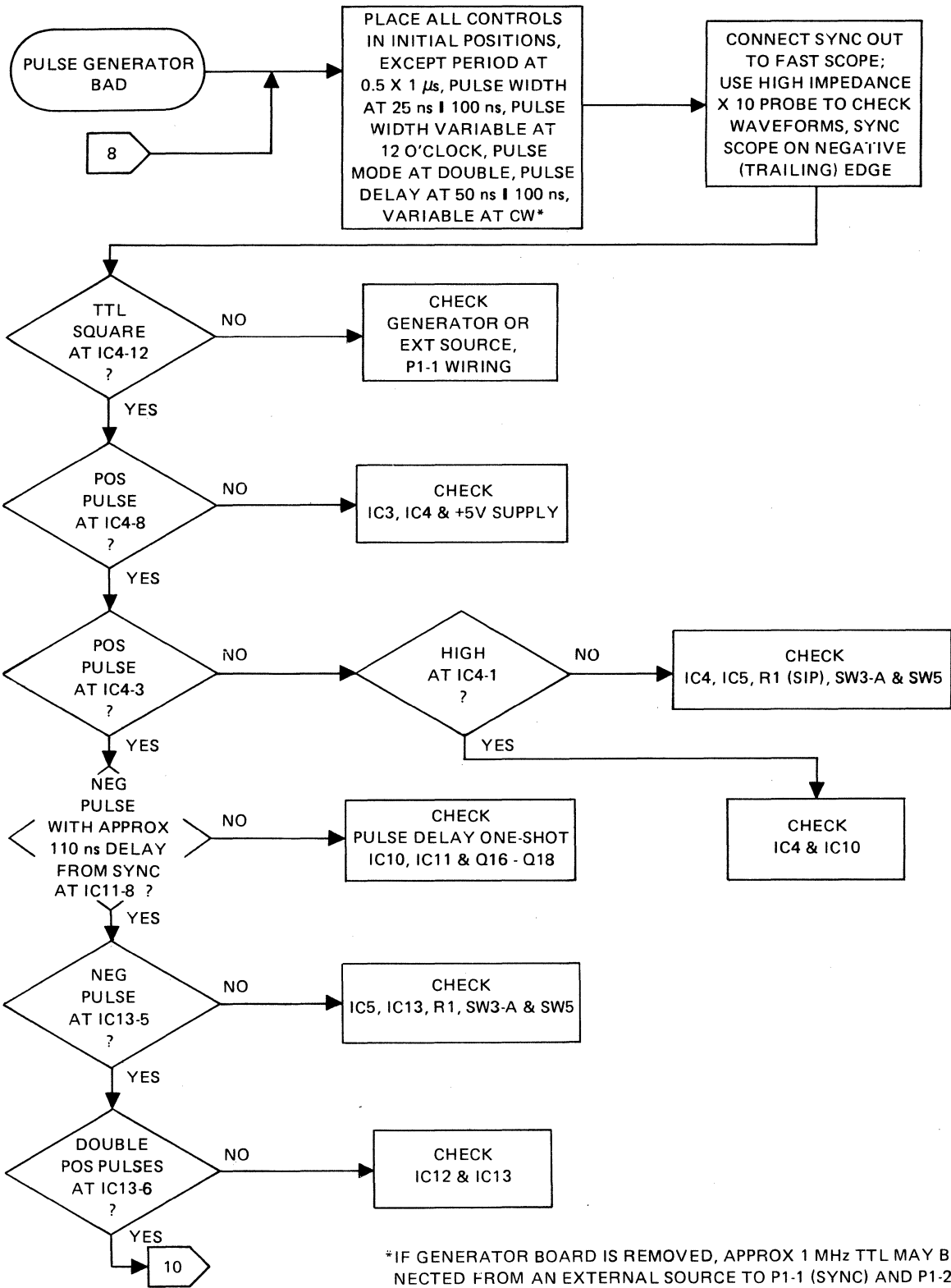

Figure 6-9. Pulse Generator Checks, Trig/Pulse Board (Page 1 of 2)

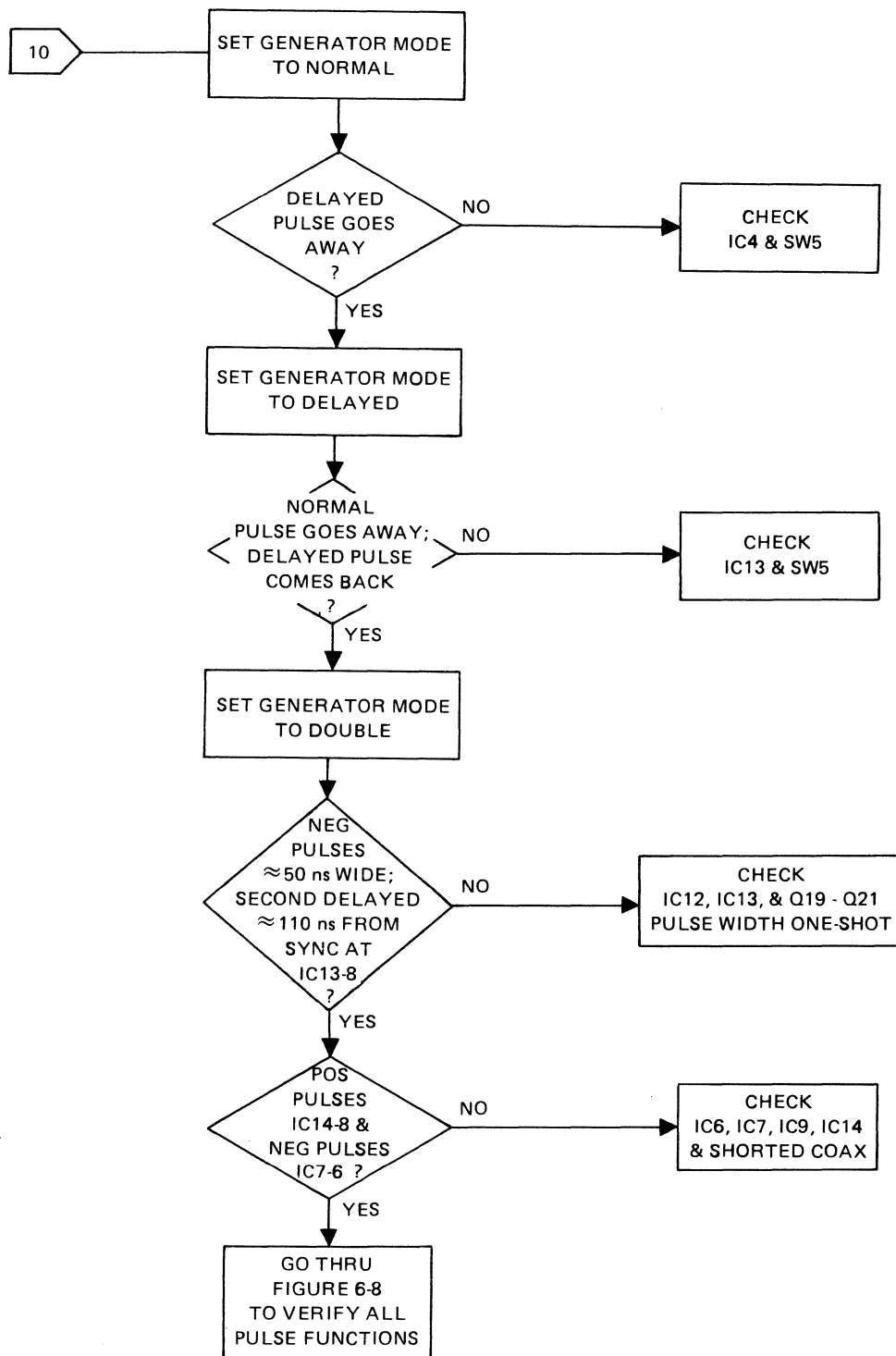

Figure 6-9. Pulse Generator Checks, Trig/Pulse Board (Page 2 of 2)

SECTION 7

PARTS AND SCHEMATICS

7.1 DRAWINGS

The following assembly drawings, schematics and parts lists are in the arrangement shown below.

Drawings	Drawing No.
Instrument Assy & Parts List	0102-00-0101
Instrument Schematic	0004-00-0101
Chassis Assy	0102-00-0575
Chassis Assy Parts List	1101-00-0575
Generator Board Schematic	0103-00-0556
Generator Board Parts Locator	1100-00-0556
Generator Board Assy (sheets 2 & 3)	0101-00-0556
Generator Board Parts List	1100-00-0556
Current Limiter Assy & Parts List	0101-00-1008
Trigger/Pulse Board Schematic	0103-00-0565
Trigger/Pulse Board Parts Locator	1100-00-0565
Trigger/Pulse Board Assy (sheet 2)	0101-00-0565
Trigger/Pulse Board Parts List	1100-00-0565
Rack Mount Assy & Parts List	0102-00-0621
Chassis Assembly	1101-00-3243
Chassis Parts List	1100-00-3243
Generator Board Schematic	1104-00-3245
Generator Board Assembly	1101-00-3245
Generator Board Parts List	1100-00-3245
Option 001 Timer Assy & Parts List	0102-00-0221
Option 003 Timer Assy	0102-00-0442
Option 003 Timer Parts List	1000-00-0442

7.2 ORDERING PARTS

When ordering spare parts, please specify part number, circuit reference, next higher assembly and serial number of the unit.

7.3 ERRATA

Under Wavetek's product improvement program, the latest electronic designs and circuits are incorporated into each Wavetek instrument as quickly as development and testing permit. Because of the time needed to compose and print instruction manuals, it is not always possible to include the most recent changes in the initial printing. Whenever this occurs, errata pages are prepared to summarize the changes made and are inserted inside the shipping carton with the instrument. If no such pages exist, the manual is correct as printed.

7.4 INDEX OF FEDERAL SUPPLY CODES

The following table gives the Federal Supply Code for Manufacturers (FSCM) for manufacturers cited in the parts lists.

MFGR Code	Manufacturer	FSCM
AMP	AMP Inc. P.O. Box 3608 Harrisburg, PA 17105	00779
ANDEV	Analog Devices Inc. 221 Fifth Street Cambridge, MA 02142	24355
ARCO	Arco Electronics Inc. Community Drive Great Neck, NY 11022	84171
BECK	Beckman Instrument Inc. 2500 Harbor Blvd. Fullerton, CA 92634	71738
BOURN	Bourns Inc. 1200 Columbia Ave. Riverside, CA 92507	32997
C&K	C&K Components Inc. 103 Morse Street Newton, MA 02158	09353
CRL	Centralab-Division of Globe Union Milwaukee, WI 53201	71590
CHIM	Chicago Miniature Lamp Works 4433 Ravenwoods Ave. Chicago, IL 60640	71744
CINCH	Cinch Manufacturing Co. 1026 S. Homan Street Chicago, IL 60624	71785
CRL	Centralab-Division of Globe Union P.O. Box 591 Milwaukee, WI 53201	71590

MFGR Code	Manufacturer	FSCM	MFGR Code	Manufacturer	FSCM
CORCM	Corman Inc. 2635 N. Kildars Ave. Chicago, IL 60639	05245	MOT	Motorola Inc. Semiconductor Production Div 5005 East McDowell Rd. Phoenix, AZ 85008	04713
CTS	CTS Corporation Elkhart, IN 46514	71450	PACRD	Packard Electric Division 408 Dana Street N.E. Warren, OH 44481	77060
FAIR	Fairchild Semiconductor Division 313 Frontage Road Mountain View, CA 94043	07263	RCA	RCA Harrison, NJ 07029	86684
FERRX	Ferroxcube Corporation of America Mount Marion Road Saugerties, NY 12477	02114	ROGAN	Rogan Bros., Inc. 8031 N. Monticello St. Skokie, IL 60076	86797
GAVTT	Gavitt Wire & Cable 455 N. Quince Street Escondido, CA 92025	23499	SEMTEC	Semitech Corporation 652 Mitchell Road Newbury Park, CA 91320	14099
IMB	IMB 15401 S. Carments Rd. Santa Fe Springs, CA 90670	27556	SMITH	Herman H. Smith 812 Snediker Avenue Brooklyn, NY 11207	83330
KING	Kings Electronics Co. Inc. 40 Marbledale Road Tuckahoe, NY 11223	91836	SPRAG	Sprage Electric Co. North Adams, MA 01247	56289
LITFU	Littelfuse Inc. 800 E. Northwest Highway Des Plaines, IL 60016	79515	STKPL	Stackpole Components P.O. Box 14466 Raleigh, NC 27610	29604
MAL	Mallory Capacitor Co. 3029 E. Washington St. P.O. Box 372 Indianapolis, IN 46206	90201	THOMN	Thompson Industries Inc. 1029 Plandome Road Manhasset, NY 11030	96881
METRS	Milton Ross Company 511 Second St. Pike Southampton, PA 18966	07047	TI	Texas Instruments North Central Exprwy Dallas, TX 75231	01295
MICRO	Micro Semiconductor Corporation 11250 Playa Court Culver City, CA 90230	14552	TRIKO	Trico Products Corp. 817 Washington Street Buffalo, NY 14203	75915
MOLEX	Molex Products Co. 5224 Katrine Avenue Docuners Grove, IL 60515	27264	TRW	TRW Electronic Components Division 666 Garland Place Des Plaines, IL 60016	18486
			UNICP	Unicorp	44729
			USECO	USECO Inc. Mt. Vernon, NY	15849
			WVTK	Wavetek 9045 Balboa Avenue San Diego, CA 92123	23338

7.5 CAPACITOR VARIANCE

Because of changes in part suppliers, certain capacitor values in your instrument may differ from those called out in the schematics and parts lists. These value variations are well within tolerable limits for correct circuit performance.

The following capacitor variations may occur in your instruments:

Assembly	Part	Ref Designation	Values
1100-00-0565	1500-35-0003	C-14, C-16	50 μ F, 50V or 47 μ F, 50V
1100-00-0565	1500-35-0103	C-6, C-8	500 μ F, 50V or 470 μ F, 50V
1100-00-0556	1500-72-7602	C-95, C-98	27 μ F, 35V or 33 μ F, 35V

THIS DOCUMENT CONTAINS PROPRIETARY INFORMATION AND DESIGN RIGHTS BELONGING TO WAVETEK AND MAY NOT BE REPRODUCED FOR ANY REASON EXCEPT CALIBRATION, OPERATION, AND MAINTENANCE WITHOUT WRITTEN AUTHORIZATION.

REV	ECN	BY	DATE	APP
4053	4058 (CL III)	A.C.T.	11/21/83	
A	6146	A.T.	2/24/84	J.R.T.

REFERENCE DESIGNATORS	PART DESCRIPTION	ORIG-MFGR-PART-NO	MFGR	WAVETEK NO.	QTY/P.T
NONE	SCHEMATIC, INSTRUMENT	0004-00-0101	WVTK	0004-00-0101	1
NONE	FINAL CAL PROCEEDURE	0006-00-0101	WVTK	0006-00-0101	1
NONE	ASSY DRWG, MODEL 145	0102-00-0101	WVTK	0102-00-0101	1
NONE	ATP FOR MODEL 145 AND OPTIONS	1002-00-0101	WVTK	1002-00-0101	1
NONE	PCA, GENERATOR	145-556	WVTK	1100-00-0556	1
NONE	STD CHASSIS	145-575	WVTK	1101-00-0575	1
NONE	KIT, FINAL ASSY -145	145-1554	WVTK	1206-00-1554	1
12	I. D. LABEL	801-9090	WVTK	1400-00-9090	1
NONE	101-7(F) INSERT	101-7	WVTK	3300-00-0003	1
NONE	CARTON 15 1/4X15 1/4X9 3/4, 200#, SINGLE, RSC	101-7A	WVTK	3300-01-0003	1
NONE	MODEL 145 INSTRUCTION MANUAL 145-STD, 145-S-620, 145-S-872, 145-S-1021	MANUAL-145	WVTK	1300-00-0101	1

WAVETEK PARTS LIST	TITLE MODEL 145 20MHZ PULSE FUNCTIONGENERATOR	ASSEMBLY NO. 1000-00-0101	REV AA
		PAGE 1	

STANDARD CHASSIS ASSEMBLY 1101-00-0575

TRIGGER PULSE PCA 1100-00-0565

GENERATOR PCA 1100-00-0556

1. FOR PARTS LIST SEE 1000-00-0101

NOTE: UNLESS OTHERWISE SPECIFIED

REMOVE ALL BURRS AND BREAK SHARP EDGES	DRAWN D. COOPER	DATE 11-8-83	WAVETEK SAN DIEGO • CALIFORNIA
MATERIAL	PROJ ENGR	11/21/83	TITLE ASSEMBLY MODEL 145
FINISH WAVETEK PROCESS	RELEASE APPROV	11/21/83	SCALE DO NOT SCALE DWG
	TOLERANCE UNLESS OTHERWISE SPECIFIED .XXX ± .010 ANGLES 1° .XX ± .030	MODEL NO. 145	DWG NO. 0102-00-0101
	CODE IDENT 23338	SHEET 1 OF 1	REV A

THIS DOCUMENT CONTAINS PROPRIETARY INFORMATION AND DESIGN RIGHTS BELONGING TO WAVETEK AND MAY NOT BE REPRODUCED FOR ANY REASON EXCEPT CALIBRATION, OPERATION, AND MAINTENANCE WITHOUT WRITTEN AUTHORIZATION.

REV	ECN	BY	DATE	APP
B	ECN 1800	JRM	9-5-8	
C	ECN 1801	JRM	9-6-8	
D	ECN 2723 AUDIT	LOU	5-19-8	
E	ECN 3881	FN	8/1/8	
F	ECN 6153	DAK	3-8-8	
G	9447			

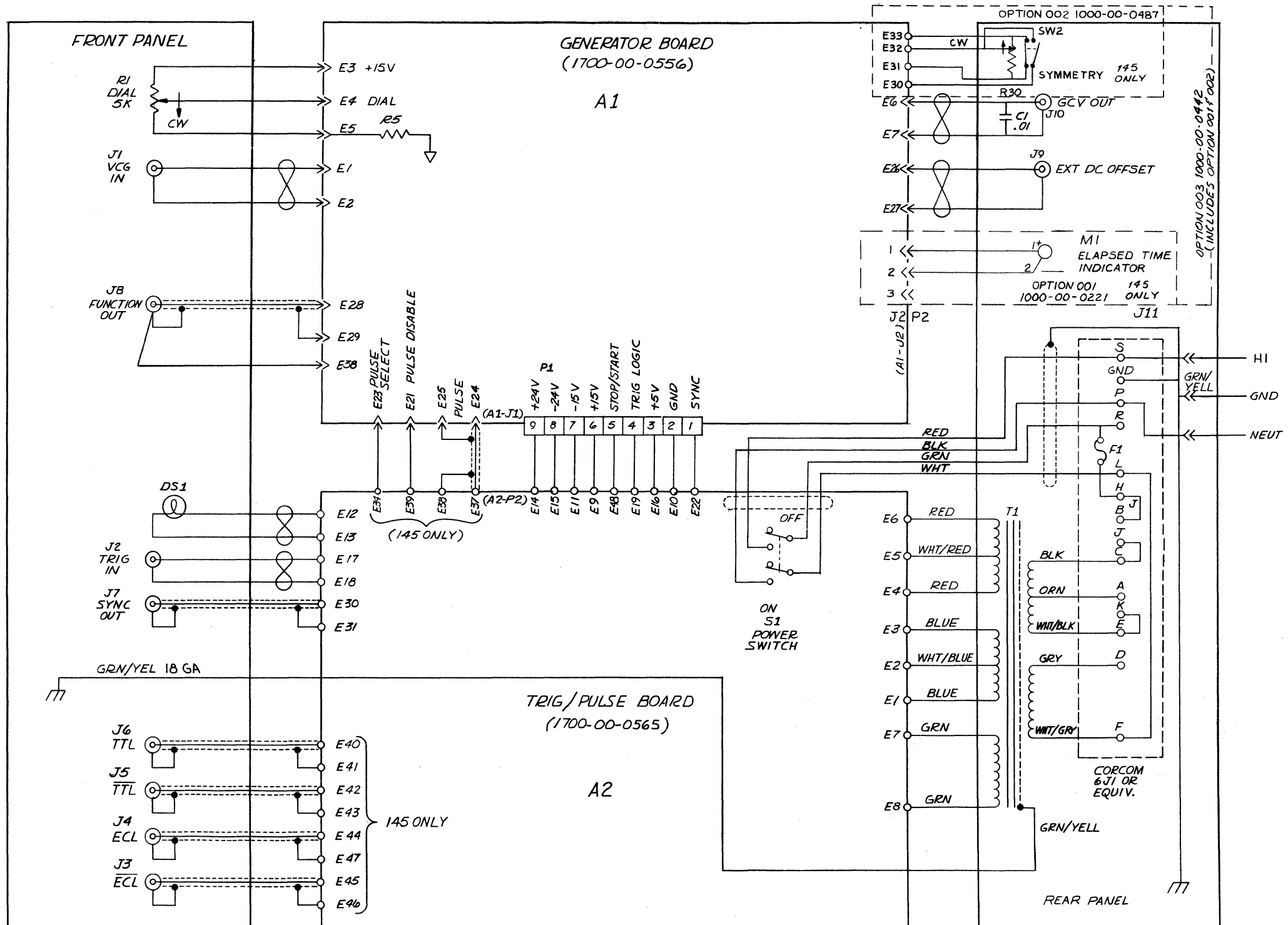

3/16A 220-240VAC
1. F1 - 3/8A 100-120 VAC

NOTE: UNLESS OTHERWISE SPECIFIED

REMOVE ALL BURRS AND BREAK SHARP EDGES	DRAWN: J. COOPER	DATE: 11-9-76	WAVETEK SAN DIEGO • CALIFORNIA
MATERIAL	PROJ ENGR:	TITLE: INSTRUMENT SCHEMATIC	
FINISH: WAVETEK PROCESS	RELEASE APPROV:	SCALE: DO NOT SCALE DWG	MODEL NO: 143/145
	TOLERANCE UNLESS OTHERWISE SPECIFIED: XXX - 010 ANGLES: 1 XX - 030	SCALE: DO NOT SCALE DWG	DWG NO: 0004-00-0101
			REV: G
			CODE IDENT: 23338 SHEET 1 OF 1

THIS DOCUMENT CONTAINS PROPRIETARY INFORMATION AND DESIGN RIGHTS BELONGING TO WAVETEK AND MAY NOT BE REPRODUCED FOR ANY REASON EXCEPT CALIBRATION, OPERATION, AND MAINTENANCE WITHOUT WRITTEN AUTHORIZATION.

NOTES:
ALL CONNECTIONS TO BE MECHANICALLY SECURE PRIOR TO SOLDERING GROUND WIRES.

REV	ECN	BY	DATE	APP
B	ECN 1806	JRM	9/1/88	
C	3360 (II)	DLH	1-16-89	
D	ECN 2091, 2124	DC	1/23/90	
E	2179	LOU	1-23-90	TRC
F	2559	LOU	2-12-91	TRC
G	2724	LOU	5-19-91	TRC
H	298E	DC	2-26-92	TRC
I	3360 (III)	JRM	9/29/92	TRC
J	ECN 3881	JP	9/14/93	TRC
K	4085, 4105 (CL III)	DLT	1/20/94	DEF
L	ECN 4938, 6146	DLT	2/19/95	A.R.T.
M	7322	AT	5/2/96	A.R.T.
N	8087	JRM	3/20/97	H.N.
O	9228	JRM	10/17/97	A.R.T.
P	ECN# 90-337	MS	5-23-90	Y.M.

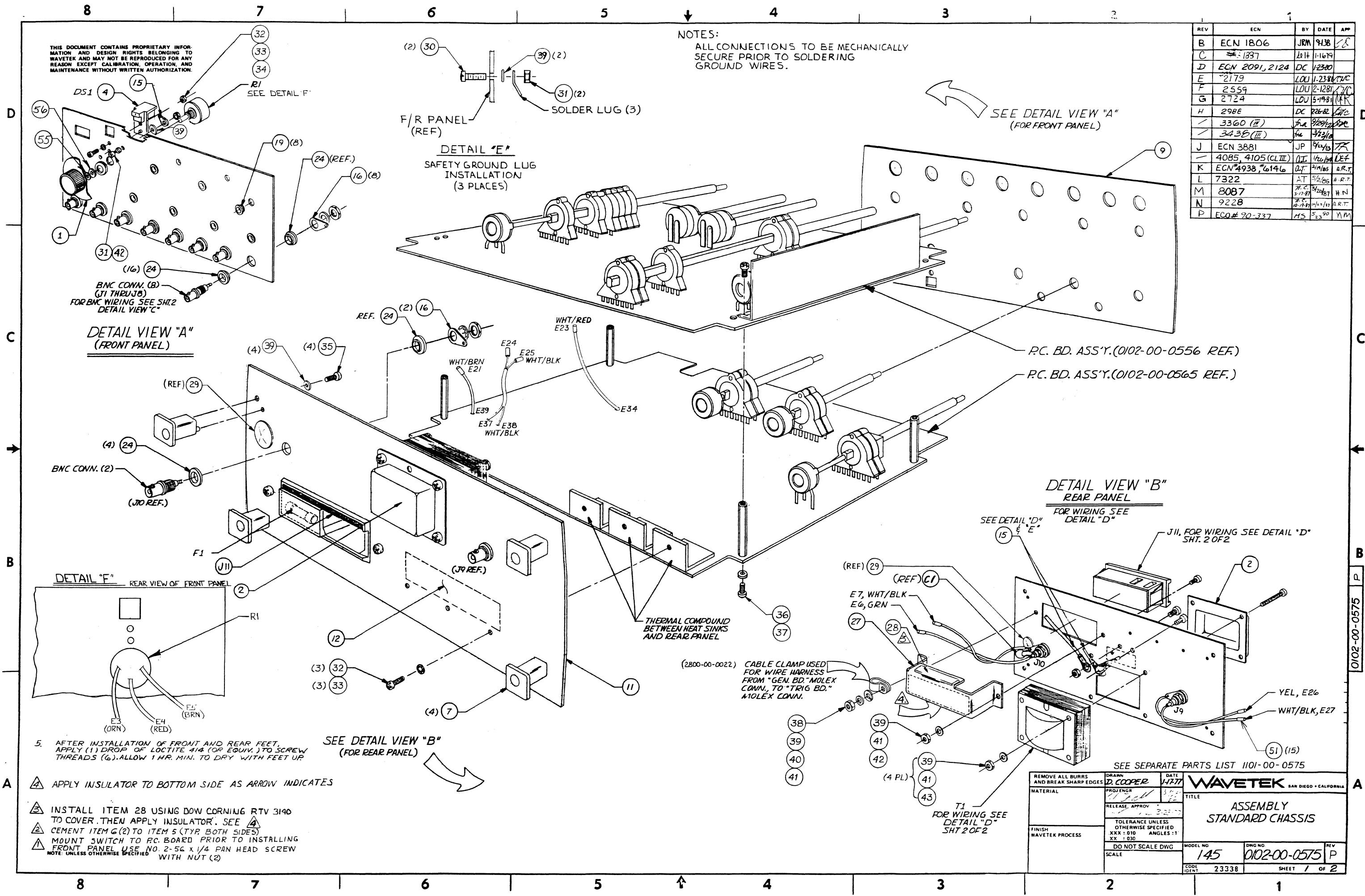

DETAIL VIEW "A"
(FRONT PANEL)

DETAIL VIEW "B"
REAR PANEL
FOR WIRING SEE
DETAIL "D"

DETAIL "E"
SAFETY GROUND LUG
INSTALLATION
(3 PLACES)

5. AFTER INSTALLATION OF FRONT AND REAR FEET, APPLY (1) DROP OF LOCTITE 414 (OR EQUIV.) TO SCREW THREADS (6). ALLOW 1 HR. MIN. TO DRY WITH FEET UP

- ▲ APPLY INSULATOR TO BOTTOM SIDE AS ARROW INDICATES
- ▲ INSTALL ITEM 28 USING DOW CORNING RTV 3140 TO COVER. THEN APPLY INSULATOR. SEE ▲
- ▲ CEMENT ITEM G(2) TO ITEM 5 (TYP. BOTH SIDES)
- ▲ MOUNT SWITCH TO RC BOARD PRIOR TO INSTALLING FRONT PANEL. USE NO. 2-56 x 1/4 PAN HEAD SCREW WITH NUT (2)

(2800-00-0022) CABLE CLAMP USED FOR WIRE HARNESS FROM "GEN. BD." MOLEX CONN., TO "TRIG. BD." MOLEX CONN.

REMOVE ALL BURRS AND BREAK SHARP EDGES		DRAWN D. COOPER	DATE 1/7/77	WAVETEK SAN DIEGO • CALIFORNIA	
MATERIAL		PROJENGR	5/2/77	TITLE ASSEMBLY STANDARD CHASSIS	
FINISH WAVETEK PROCESS		RELEASE APPROV	3/22/77	TOLERANCE UNLESS OTHERWISE SPECIFIED XXX : 010 ANGLES : 1 XX : 030	
SCALE DO NOT SCALE DWG		MODEL NO 145	DWG NO 0102-00-0575	REV P	
		CODE IDENT 23338	SHEET 1 OF 2		

0102-00-0575

A

THIS DOCUMENT CONTAINS PROPRIETARY INFORMATION AND DESIGN RIGHTS BELONGING TO WAVETEK AND MAY NOT BE REPRODUCED FOR ANY REASON EXCEPT CALIBRATION, OPERATION, AND MAINTENANCE WITHOUT WRITTEN AUTHORIZATION.

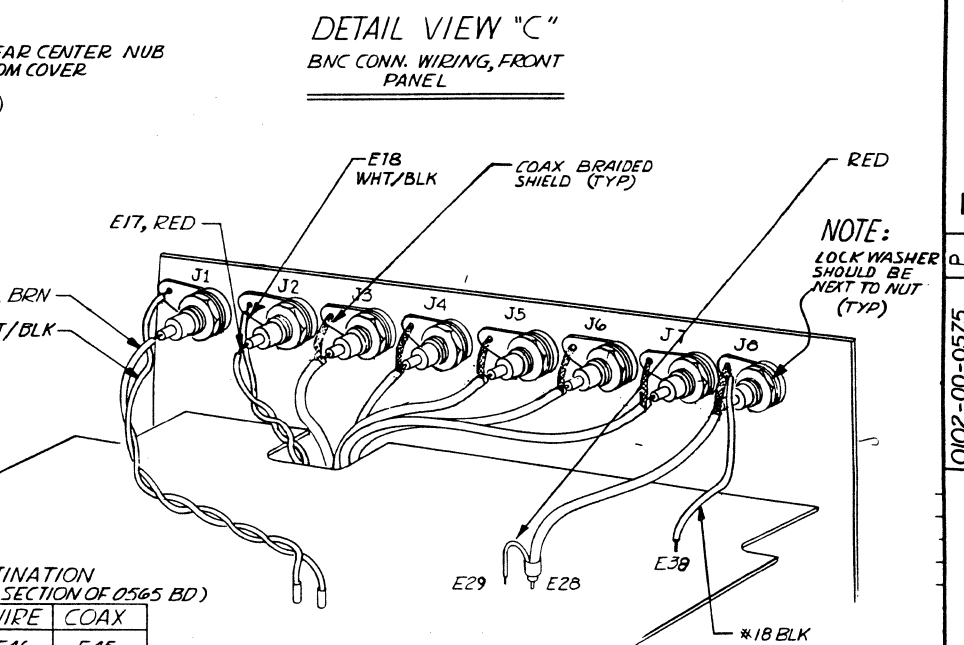
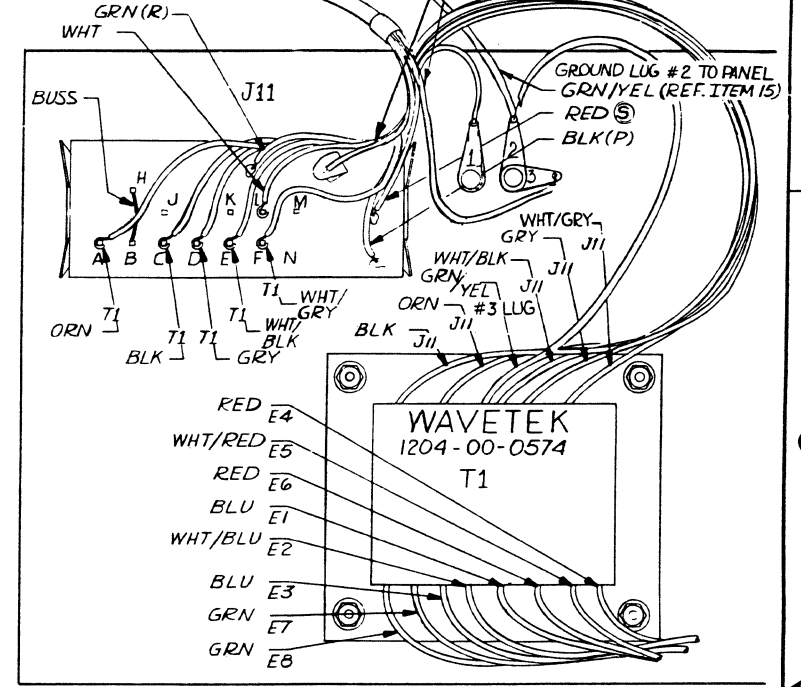
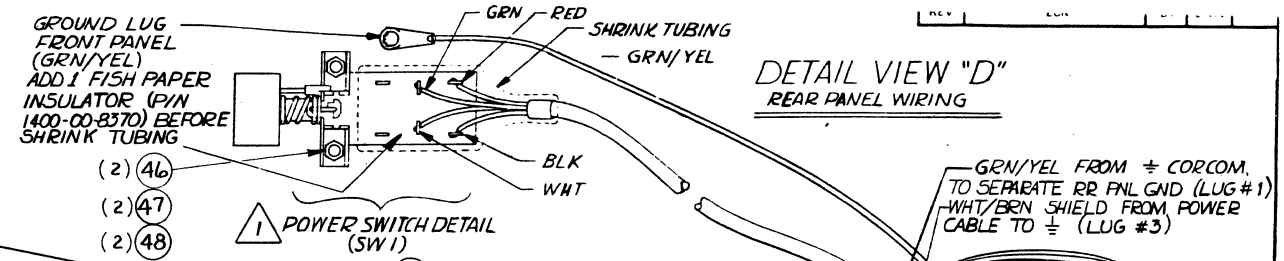

WIRE DESTINATION
(OUTPUT BUFFER SECTION OF 0565 BD)

FROM	WIRE COLOR	WIRE	COAX
J3	WHT/ORN	E46	E45
J4	WHT/YEL	E47	E44
J5	WHT/GRN	E43	E42
J6	WHT/BLU	E41	E40
J7	WHT/VIO	E31	E30

REMOVE ALL BURRS AND BREAK SHARP EDGES	DRAWN: D. COOPER	DATE: 1/8/77	WAVETEK SAN DIEGO • CALIFORNIA
MATERIAL	PROJ. NO. 12418	DATE: 3/29/83	
FINISH WAVETEK PROCESS	RELEASE APPROV. [Signature]	DATE: 3-23-77	TITLE: ASSEMBLY STANDARD CHASSIS
	TOLERANCE UNLESS OTHERWISE SPECIFIED	XXX - 010 ANGLES - 1	MODEL NO. 145
	DO NOT SCALE DWG	SCALE	DWG NO. 0102-00-0575
			REV. P
			CODE 23338
			SHEET 2 OF 2

NOTE: UNLESS OTHERWISE SPECIFIED

8 7 6 5 4 3 2 1

0102-00-0575

THIS DOCUMENT CONTAINS PROPRIETARY INFORMATION AND DESIGN RIGHTS BELONGING TO WAVETEK AND MAY NOT BE REPRODUCED FOR ANY REASON EXCEPT CALIBRATION, OPERATION, AND MAINTENANCE WITHOUT WRITTEN AUTHORIZATION.

REV ECO BY DATE APP

REFERENCE DESIGNATORS	PART DESCRIPTION	ORIG-MFGR-PART-NO	MFGR	WAVETEK NO.	QTY/PT
NONE	ASSY DRWG, CHASSIS	0102-00-0575	WVTK	0102-00-0575	1
NONE	PCA, TRIGGER/PULSE	145-565	WVTK	1100-00-0565	1
NONE	ASSY, FRONT PANEL -145	145-1555	WVTK	1206-00-1555	1
NONE	ASSY, REAR PANEL -145	145-1556	WVTK	1206-00-1556	1
27	SHIELD, PWR	801-6210	WVTK	1400-00-6210	1
NONE	INSULATOR PLATE REF: 3200-03-0004	145-3931	WVTK	1400-01-3931	1
18	COAX KNOB SET	RB-67-1-SB+O-M-9	ROGAN	2400-01-0009	3
NONE	CLAMP, CABLE	E-4	RICH	2800-00-0022	1
48	WASHER, LOCK, SPLIT S/S #2	MS3533B-134	MS	2800-45-2000	2
33	WASHER, LOCK REG, S/S #4	MS 3533B-135	CMRCL	2800-45-4000	3
39	WASHER, LOCK, REG S/S #6	MS 3533B-136	CMRCL	2800-45-6000	9
40	WASHER, FLAT, SS, #6 LARGE OUTLINE	AN 960C6	CMRCL	2800-46-6001	1
46	SCREW PLPS PAN M/S 18-8 S/S 2-56X1/4	SCREW PH 2-56X1/4S/S	CMRCL	2800-48-2104	2

WAVETEK
PARTS LIST

TITLE
STD CHASSIS

ASSEMBLY NO. 1101-00-0575
PAGE 1

REV
P

REFERENCE DESIGNATORS	PART DESCRIPTION	ORIG-MFGR-PART-NO	MFGR	WAVETEK NO.	QTY/PT
NONE	ASSY DRWG, CHASSIS	0102-00-0575	WVTK	0102-00-0575	1
NONE	DIAL ASSY-145	1201-00-1885	WVTK	1201-00-1885	1
4	INDICATOR, DIAL	180-303	WVTK	1400-00-4970	1
9	PANEL, FRONT	145-6770	WVTK	1400-00-6770	1
J1 J2 J3 J4 J5 J6 J7 J8	CONN BNC	KC-7946	KING	2100-01-0002	8
16	SOLDER LUG	1497	SMITH	2100-04-0012	8
15	SOLDER LUG	11A144	ZIER	2100-04-0025	1
19	BUSHING NYLINER	4L2FF	THOMN	2800-01-0002	8
24	WASHER, SHOULDER, WHITE	2668	SMITH	2800-27-0004	16
55	WASHER, WAVE SPRING	5804-133-1	SEA	2800-28-0021	1
56	WASHER, FLAT, BRASS, .025 ID, .400 OD	5714-62-32	SESTM	2800-28-0022	1
33	WASHER, LOCK REG, S/S #4	MS 3533B-135	CMRCL	2800-45-4000	1
32	SCREW PLPS PAN M/S 18-8 S/S 4-40X3/8	MS 51957-15	CMRCL	2800-48-4106	1
42	SCREW PLPS PAN M/S 18-8 S/S 6-32X3/8	MS 51957-28	CMRCL	2800-48-6106	1
34	NUT, MACHINE SCREW	NAS 671C4	CMRCL	2800-50-4100	1

WAVETEK
PARTS LIST

TITLE
ASSY, FRONT PANEL -145

ASSEMBLY NO. 1206-00-1555
PAGE 1

REV
B

REFERENCE DESIGNATORS	PART DESCRIPTION	ORIG-MFGR-PART-NO	MFGR	WAVETEK NO.	QTY/PT
NONE	ASSY DRWG, CHASSIS	0102-00-0575	WVTK	0102-00-0575	1
T1	TRANSFORMER	143-574	WVTK	1204-00-0574	1
NONE	ASSY, CONDUCTOR CABLE 143-145	143-145-1959	WVTK	1207-00-1959	1
2	END BELL	1400-00-0174	WVTK	1400-00-0174	1
7	POST	180-302	WVTK	1400-00-5020	4
11	PANEL, REAR	145-6760	WVTK	1400-00-6760	1
NONE	INSULATOR, PWR SWITCH REF: 1600-99-0001	801-8370	WVTK	1400-00-8370	1
C1	CAP CER MDN .01MF 50V, AXIAL	CAC02Z5U103Z100A	CORNG	1500-01-0310	1
J10 J9	CONN BNC	KC-7946	KING	2100-01-0002	2
J11	CONN, RECEPTACLE	6VJ1	CORCM	2100-03-0026	1
16A	SOLDER LUG	1497	SMITH	2100-04-0012	2
15A	SOLDER LUG	11A144	ZIER	2100-04-0025	3
F1	FUSE, 1/2A, 250V	313.500	LITFU	2400-05-0010	1
24	WASHER, SHOULDER, WHITE	2668	SMITH	2800-27-0004	4
29	PLUG BUTTON	2663(BLACK)	HEYCD	2800-35-0004	1

WAVETEK
PARTS LIST

TITLE
ASSY, REAR PANEL -145

ASSEMBLY NO. 1206-00-1556
PAGE 1

REV
C

REFERENCE DESIGNATORS	PART DESCRIPTION	ORIG-MFGR-PART-NO	MFGR	WAVETEK NO.	QTY/PT
32	SCREW PLPS PAN M/S 18-8 S/S 4-40X3/8	MS 51957-15	CMRCL	2800-48-4106	3
42	SCREW PLPS PAN M/S 18-8 S/S 6-32X3/8	MS 51957-28	CMRCL	2800-48-6106	1
38	SCREW, MACH, PH, PHLPS, 6-32 X 1/2, SS 18-8 SS, #6-32X1/2	MS 51957-30	CMRCL	2800-48-6108	1
47	NUT, MACHINE SCREW, 18-8 SS, #2-56	2-56 M/S NUT 18-8 S/S	CMRCL	2800-50-2100	2
41	NUT, MACHINE SCREW, 18-8 SS, #6-32	MS 35649-64	CMRCL	2800-50-6101	2

WAVETEK
PARTS LIST

TITLE
STD CHASSIS

ASSEMBLY NO. 1101-00-0575
PAGE 2

REV
P

REFERENCE DESIGNATORS	PART DESCRIPTION	ORIG-MFGR-PART-NO	MFGR	WAVETEK NO.	QTY/PT
31	18-8 SS, #4-40 NUT, LOCKING, MS, 6-32, SS 18-8 SS, #6-32	MS 20364-632	CMRCL	2800-50-6102	1
R1	POT, DIAL, 5K+/-5%, PRECISION, LINEAR	ECOND POT MKIII 78PF-14	NEI	4600-05-0212	1

WAVETEK
PARTS LIST

TITLE
ASSY, FRONT PANEL -145

ASSEMBLY NO. 1206-00-1555
PAGE 2

REV
B

REFERENCE DESIGNATORS	PART DESCRIPTION	ORIG-MFGR-PART-NO	MFGR	WAVETEK NO.	QTY/PT
39	WASHER, LOCK, REG S/S #6	MS 3533B-136	CMRCL	2800-45-6000	4
NONE	WASHER, FLAT, SS, #6 LARGE OUTLINE	AN 960C6	CMRCL	2800-46-6001	4
43	MS, PH, PHLPS, 6-32 X 1 1/2, SS 18-8 SS, #6-32X1.5	MS 51957-36	CMRCL	2800-48-6124	4
30	SCREW, CAP, SOCKET HD, 6-32X3/8	MS 16995-17	CMRCL	2800-49-6106	2
41	NUT, MACHINE SCREW, 18-8 SS, #6-32	MS 35649-64	CMRCL	2800-50-6101	4
31	NUT, LOCKING, MS, 6-32, SS 18-8 SS, #6-32	MS 20364-632	CMRCL	2800-50-6102	2
35	SCREW, SELF-TAP, PH, PHL PS, #6 X 3/8, SS TYPE BF, #6X3/8	MS24626-19	CMRCL	2800-59-6006	4
SW1	SWITCH ASSY PB	1XTA0003TA100B-W/NE152	ECO	5102-00-0008	1
NONE	PWR CORD	17251	BELDN	6001-80-0005	1

WAVETEK
PARTS LIST

TITLE
ASSY, REAR PANEL -145

ASSEMBLY NO. 1206-00-1556
PAGE 2

REV
C

REMOVE ALL BURRS AND BREAK SHARP EDGES	DRAWN	DATE	 PARTS LIST STD CHASSIS
MATERIAL	CHECKED	TITLE	
FINISH: WAVETEK PROCESS	PROJ. ENGR.	RELEASE APPROV.	
UNLESS OTHERWISE SPECIFIED DIMENSIONS ARE IN INCHES TOLERANCES ARE: FRACTIONS DECIMALS ANGLES	SIZE	FSCM NO.	
DO NOT SCALE DRAWING	SCALE	MODEL	SHEET

NOTE: UNLESS OTHERWISE SPECIFIED

THIS DOCUMENT CONTAINS PROPRIETARY INFORMATION AND DESIGN RIGHTS BELONGING TO WAVETEK AND MAY NOT BE REPRODUCED FOR ANY REASON EXCEPT CALIBRATION, OPERATION, AND MAINTENANCE WITHOUT WRITTEN AUTHORIZATION.

REV	ECN	BY	DATE	APP
B	ECN 1545	RO	6-6-77	
C	ECN 1625	RO	11-3-77	
D	ECN 1800	JRM	9-5-81	
E	ECN 2089	DC	1-23-80	JAC
F	ECN 2123	LJTE	4-17-80	JAC

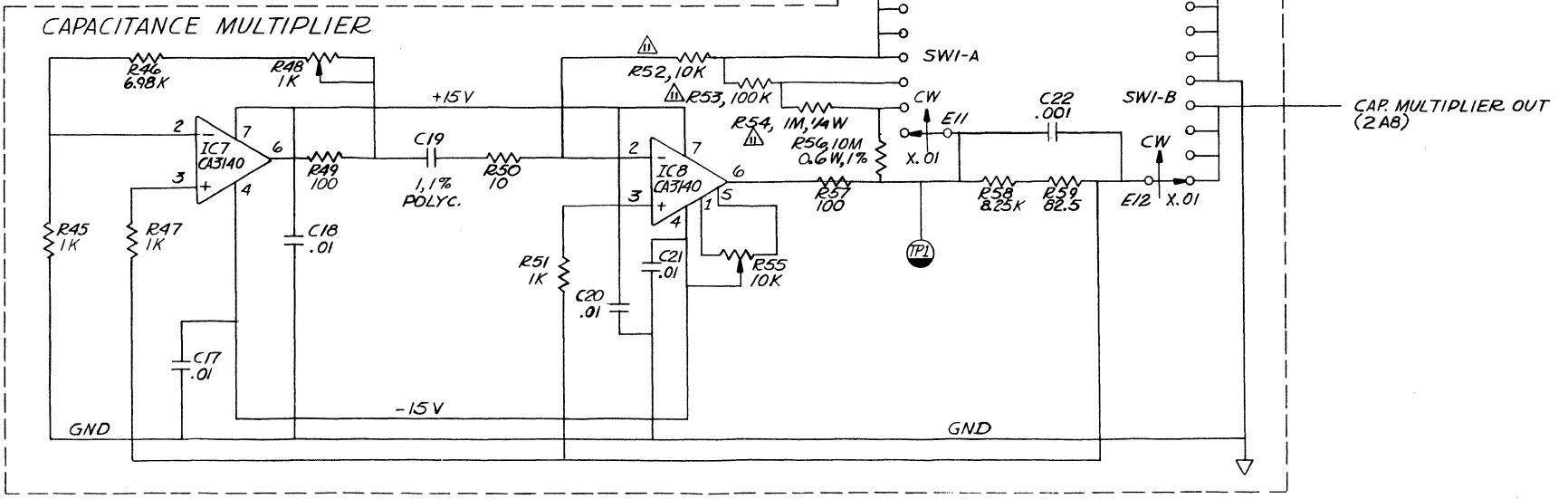
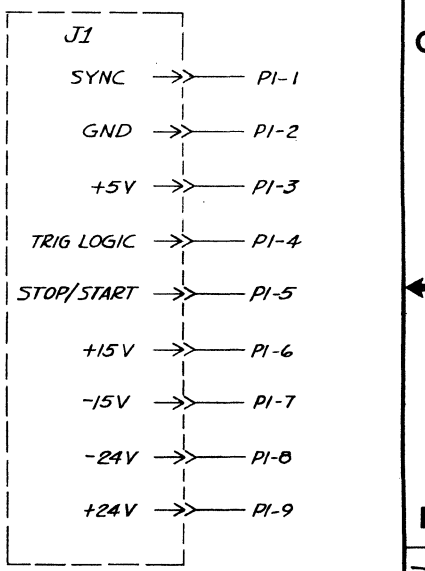
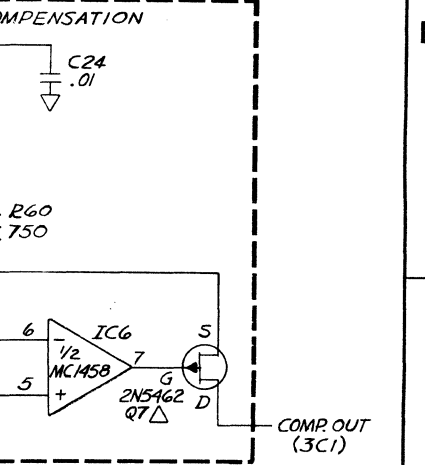
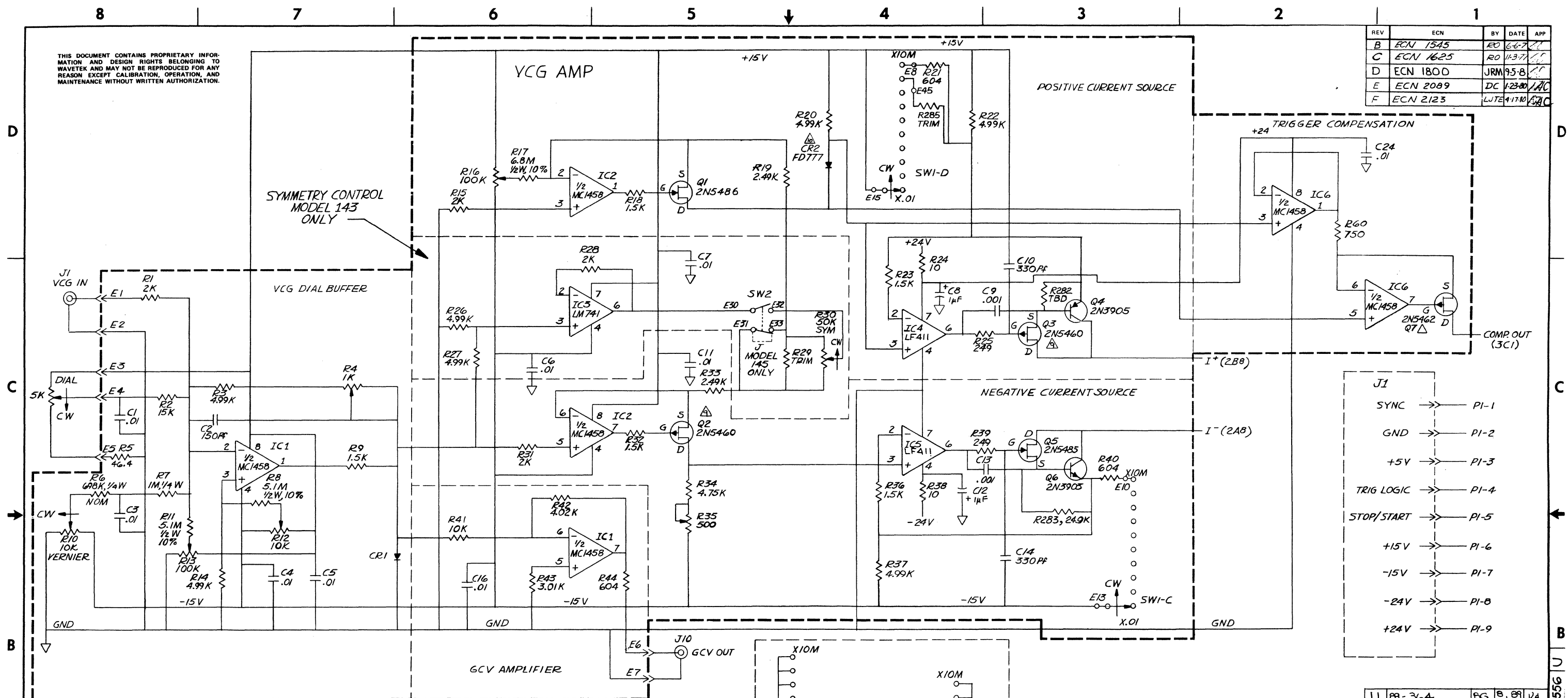

- * = NOMINAL VALUE CALLED OUT ON P/L.
- △ = MATCHED SET OF 3 RESISTORS
- ▲ = MATCHED PAIR OF FD-777 DIODES (OTHER ON SHT. 3 OF 4)
- ▲ = SELECTED COMPONENT
- △ = MATCHED SET OF (2) 2N5485
- ▲ = MATCHED SET OF (2) 2N3563
- △ = MATCHED SET OF (3) CAPACITORS
- ▲ = MATCHED SET OF (8) FD777 DIODES
- 4. DIODES ARE FD6666
- 3. RESISTORS ARE 1/8W, 1% MF
- 2. CAPACITANCE IN MICROFARADS
- 1. RESISTANCE IN OHMS

NOTE: UNLESS OTHERWISE SPECIFIED

SEE SEPARATE PART LIST
1100-00-0556

REMOVE ALL BURRS AND BREAK SHARP EDGES	DRAWN D. COFFEE	DATE 11/2/77
MATERIAL	PROJ ENGR	
FINISH WAVETEK PROCESS	RELEASE APPROV WAVETEK	TOLERANCE UNLESS OTHERWISE SPECIFIED XXX .010 ANGLES .1 XX .030
DO NOT SCALE DWG	MODEL NO 143/145	DWG NO 0103-00-0556
SCALE	CODE IDENT 23338	REV U

U	89-364	EG	B, B9	RA
T	7786	JT	12/2/86	A.R.T.
S	4938,6153	ACT	1/28/86	A.R.T.
R	4664,4864	DAH	1/22/85	A.R.T.
Q	4132,4133,4082	DTG	1/23/84	PT
-	#4074 (CL III)	DTG	1/19/84	PT
P	3881	FN	9/15/83	PT
-	3617 (CL III)	fn	3/22/83	PT
N	3516, 3517	fn	1/19/83	PT
M	2988,2985,2987,2984	DC	8-26-82	PT
L	2950, 2951	fn	12/15/81	PT
K	2877, 2878	fn	10/20/81	PT
J	ECN* 2817, 2819	DC	8-25-81	PT
H	2736	LDU	6-5-81	PT
G	ECN 2353, 2354	LOLU	11-7-80	PT

WAVETEK SAN DIEGO • CALIFORNIA
TITLE
SCHEMATIC GENERATOR BOARD

MODEL NO: 143/145
DWG NO: 0103-00-0556
REV: U
SHEET 1 OF 4

THIS DOCUMENT CONTAINS PROPRIETARY INFORMATION AND DESIGN RIGHTS BELONGING TO WAVETEK AND MAY NOT BE REPRODUCED FOR ANY REASON EXCEPT CALIBRATION, OPERATION, AND MAINTENANCE WITHOUT WRITTEN AUTHORIZATION.

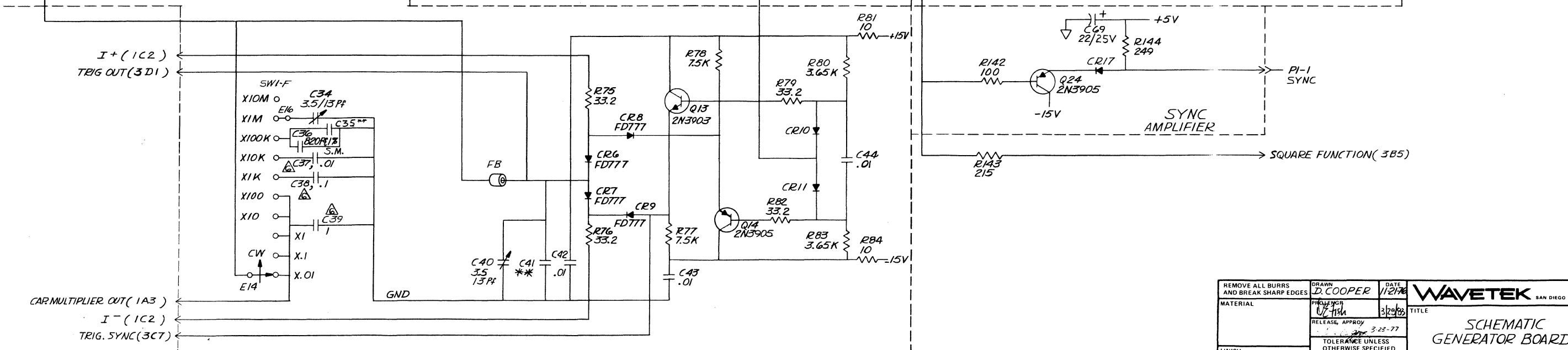
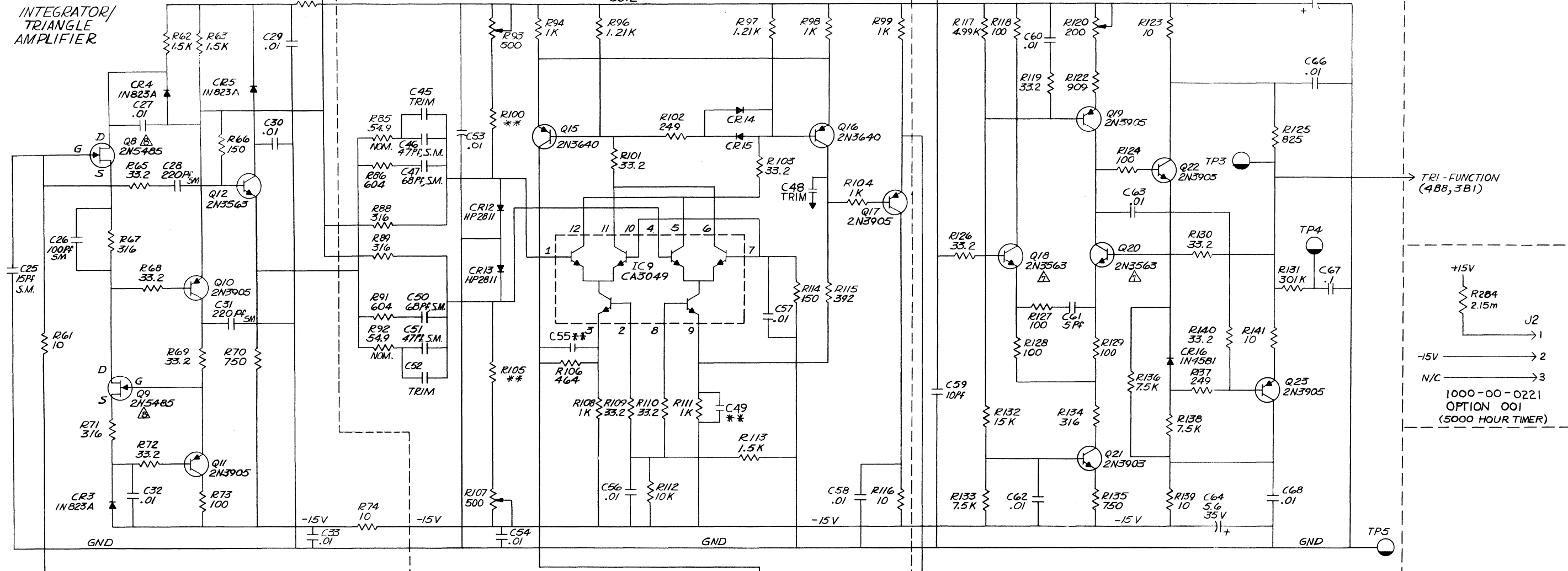

NOTE: UNLESS OTHERWISE SPECIFIED

REMOVE ALL BURRS AND BREAK SHARP EDGES	DRAWN D. COOPER	DATE 1/21/76	WAVETEK SAN DIEGO • CALIFORNIA
MATERIAL	PROJECTOR	3/29/76	
FINISH WAVETEK PROCESS	RELEASE APPROV	3-23-77	TITLE
	TOLERANCE UNLESS OTHERWISE SPECIFIED XXX .010 ANGLES 1:1 XX .030		SCHEMATIC GENERATOR BOARD
SCALE	DO NOT SCALE DWG	MODEL NO. 143/145	DWG NO. 0103-00-0556
		CODE IDENT 23338	REV U
		SHEET 2 OF 4	

0103-00-0556 T

THIS DOCUMENT CONTAINS PROPRIETARY INFORMATION AND DESIGN RIGHTS BELONGING TO WAVETEK AND MAY NOT BE REPRODUCED FOR ANY REASON EXCEPT CALIBRATION, OPERATION, AND MAINTENANCE WITHOUT WRITTEN AUTHORIZATION.

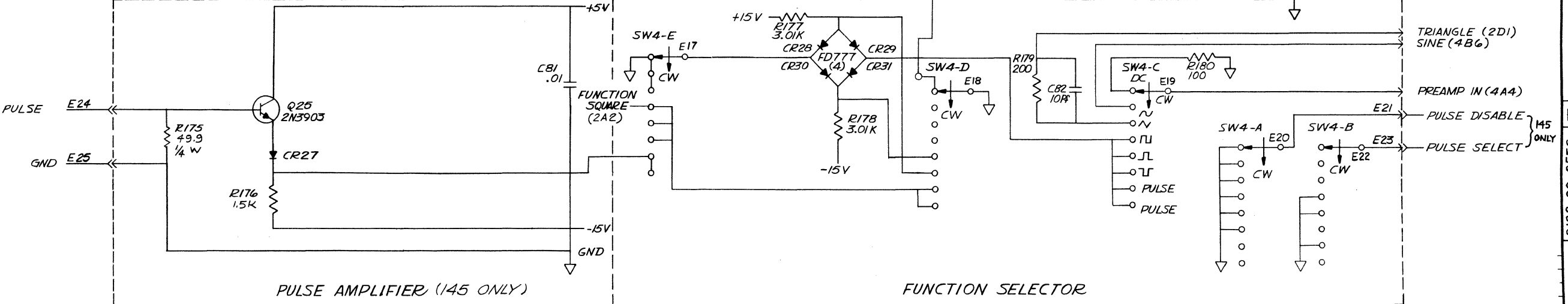
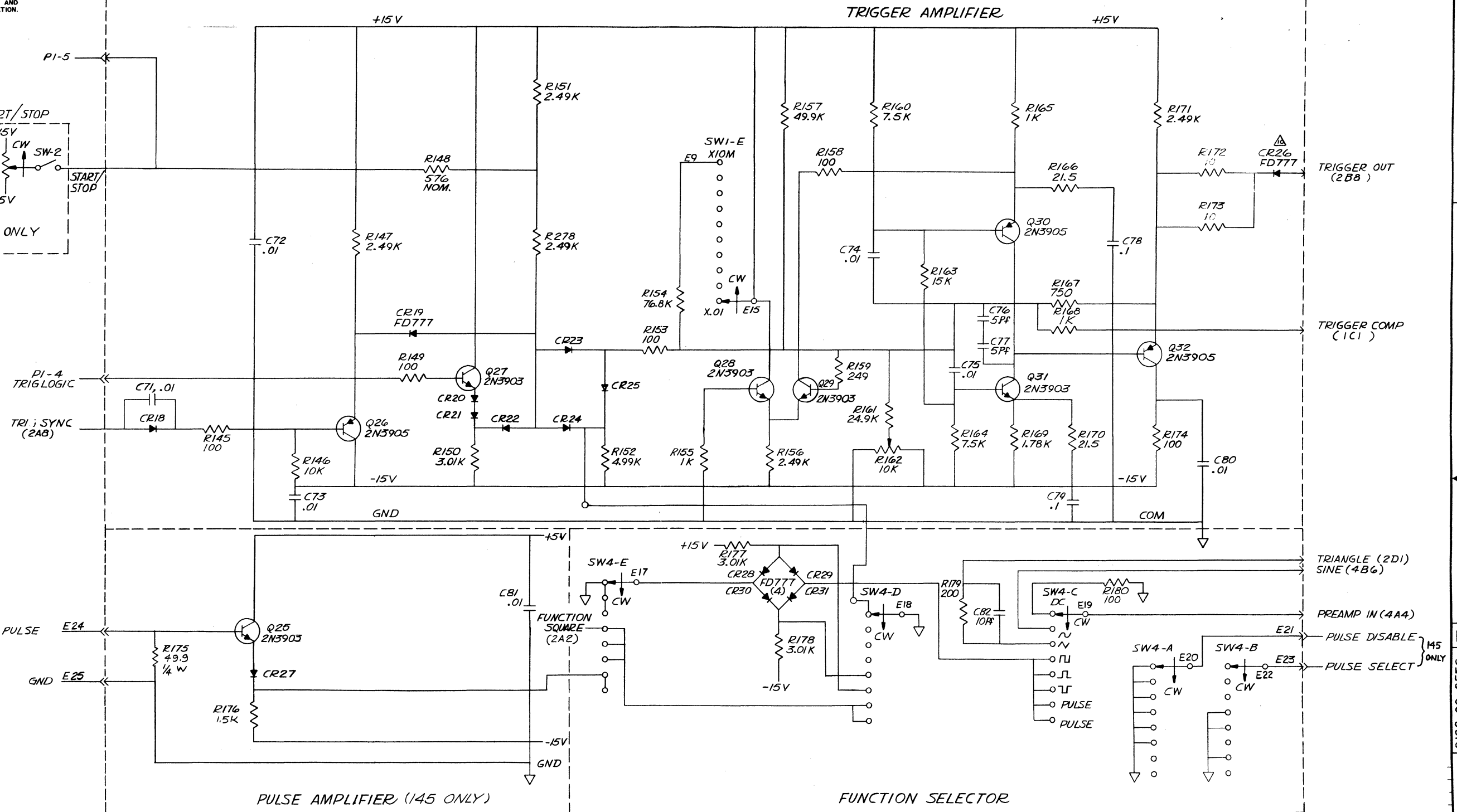
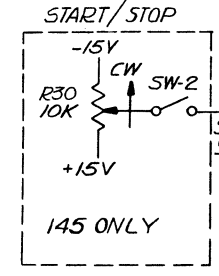

NOTE: UNLESS OTHERWISE SPECIFIED

REMOVE ALL BURRS AND BREAK SHARP EDGES	DRAWN D. COOPER	DATE 11-8-76	
MATERIAL	PROJ ENGR W. J. H.	DATE 7/1/78	
FINISH WAVETEK PROCESS	RELEASE APPROV J. L. H.	DATE 5-27-77	TOLERANCE UNLESS OTHERWISE SPECIFIED .XXX ± 0.10 ANGLES .1 XX ± .030 DO NOT SCALE DWG SCALE
			MODEL NO. 143/145 DWG NO. 0103-00-0556 REV U CODE IDENT 23338 SHEET 3 OF 4

0103-00-0556 T

THIS DOCUMENT CONTAINS PROPRIETARY INFORMATION AND DESIGN RIGHTS BELONGING TO WAVETEK AND MAY NOT BE REPRODUCED FOR ANY REASON EXCEPT CALIBRATION, OPERATION, AND MAINTENANCE WITHOUT WRITTEN AUTHORIZATION.

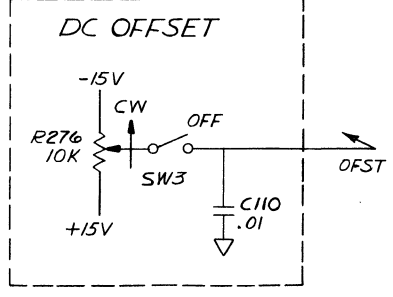
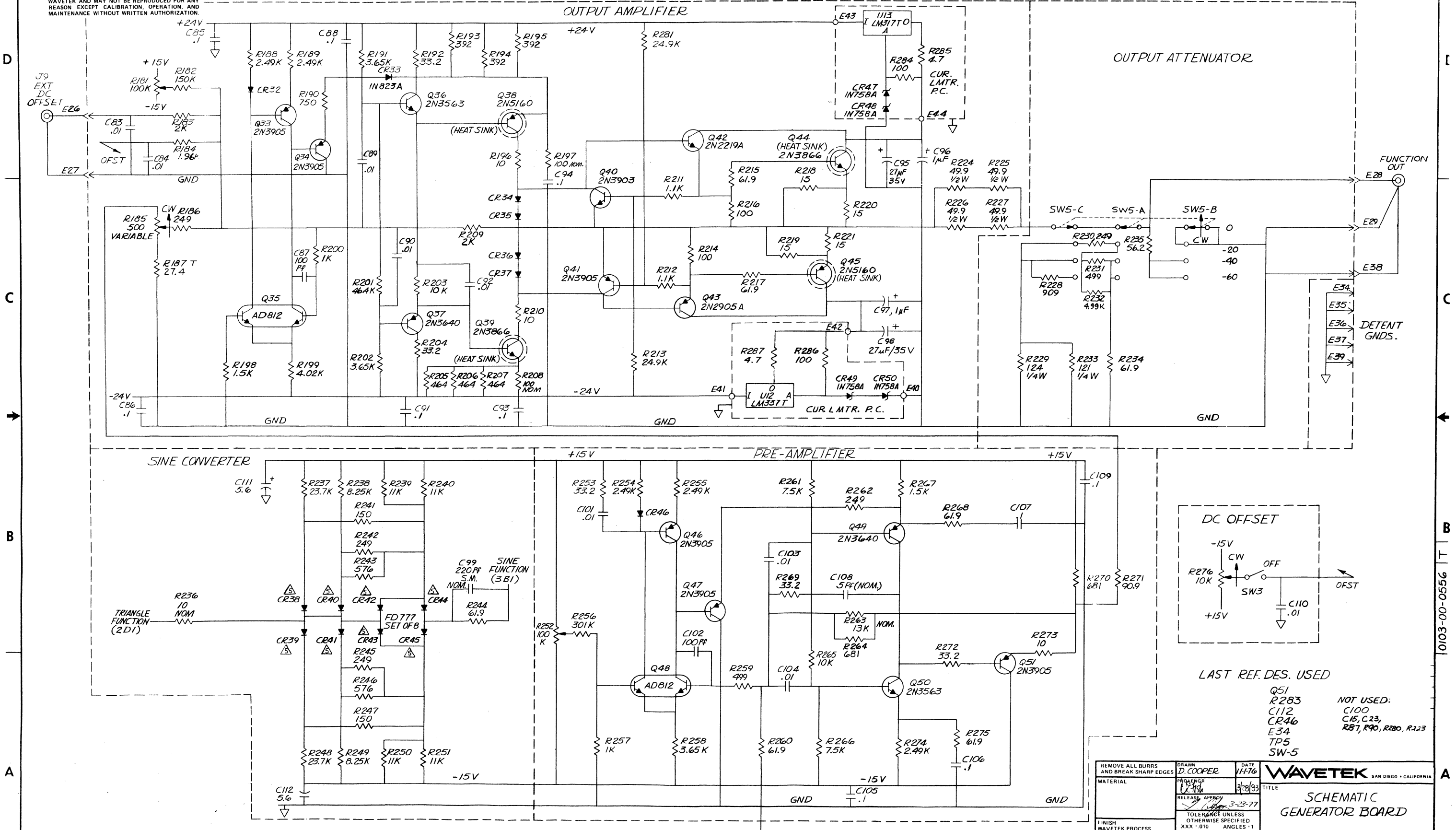

- LAST REF. DES. USED
- Q51
 - R283
 - C112
 - CR46
 - E34
 - TP5
 - SW-5
- NOT USED:
- C100
 - C15, C23
 - R87, R90, R80, R223

NOTE: UNLESS OTHERWISE SPECIFIED

REMOVE ALL BURRS AND BREAK SHARP EDGES	DRAWN D. COOPER	DATE 11/76	WAVETEK SAN DIEGO • CALIFORNIA
MATERIAL	PRODUCTION 1/8/83	RELEASE APPROVAL 3-23-77	TITLE SCHEMATIC GENERATOR BOARD
FINISH WAVETEK PROCESS	DO NOT SCALE DWG	MODEL NO. 143/145	DWG NO. 0103-00-0556
SCALE	CODE IDENT 23338	SHEET 4	OF 4

THIS DOCUMENT CONTAINS PROPRIETARY INFORMATION AND DESIGN RIGHTS BELONGING TO WAVETEK AND MAY NOT BE REPRODUCED FOR ANY REASON EXCEPT CALIBRATION, OPERATION, AND MAINTENANCE WITHOUT WRITTEN AUTHORIZATION.

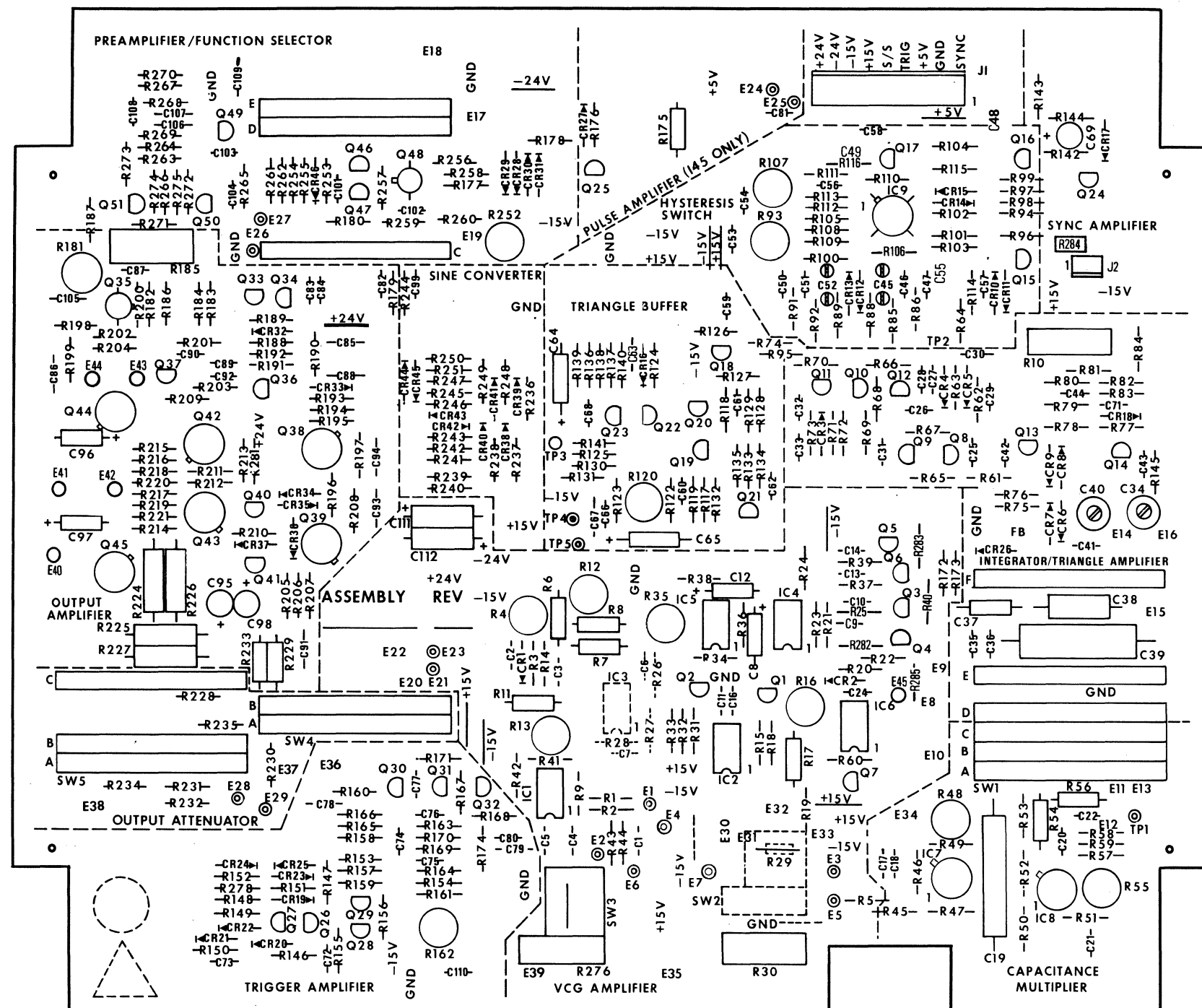

MADE FROM 0100-00-0556-3F

REMOVE ALL BURRS AND BREAK SHARP EDGES	DRAWN	DATE	WAVETEK SAN DIEGO • CALIFORNIA	
	PROJ ENGR			
FINISH WAVETEK PROCESS	RELEASE APPROV		TITLE PCA, GENERATOR BD	
	TOLERANCE UNLESS OTHERWISE SPECIFIED XXX - 010 ANGLES - 1 XX - 030			
	DO NOT SCALE DWG	MODEL NO	DWG NO	REV
	SCALE	145	1100-00-0556	
	CODE IDENT	23338	SHEET	OF

THIS DOCUMENT CONTAINS PROPRIETARY INFORMATION AND DESIGN RIGHTS BELONGING TO WAVETEK AND MAY NOT BE REPRODUCED FOR ANY REASON EXCEPT CALIBRATION, OPERATION, AND MAINTENANCE WITHOUT WRITTEN AUTHORIZATION.

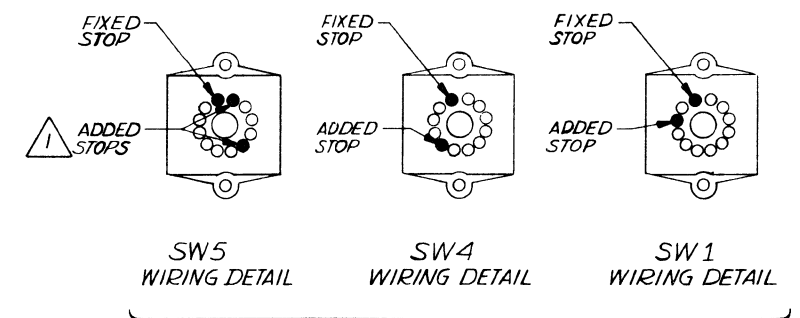
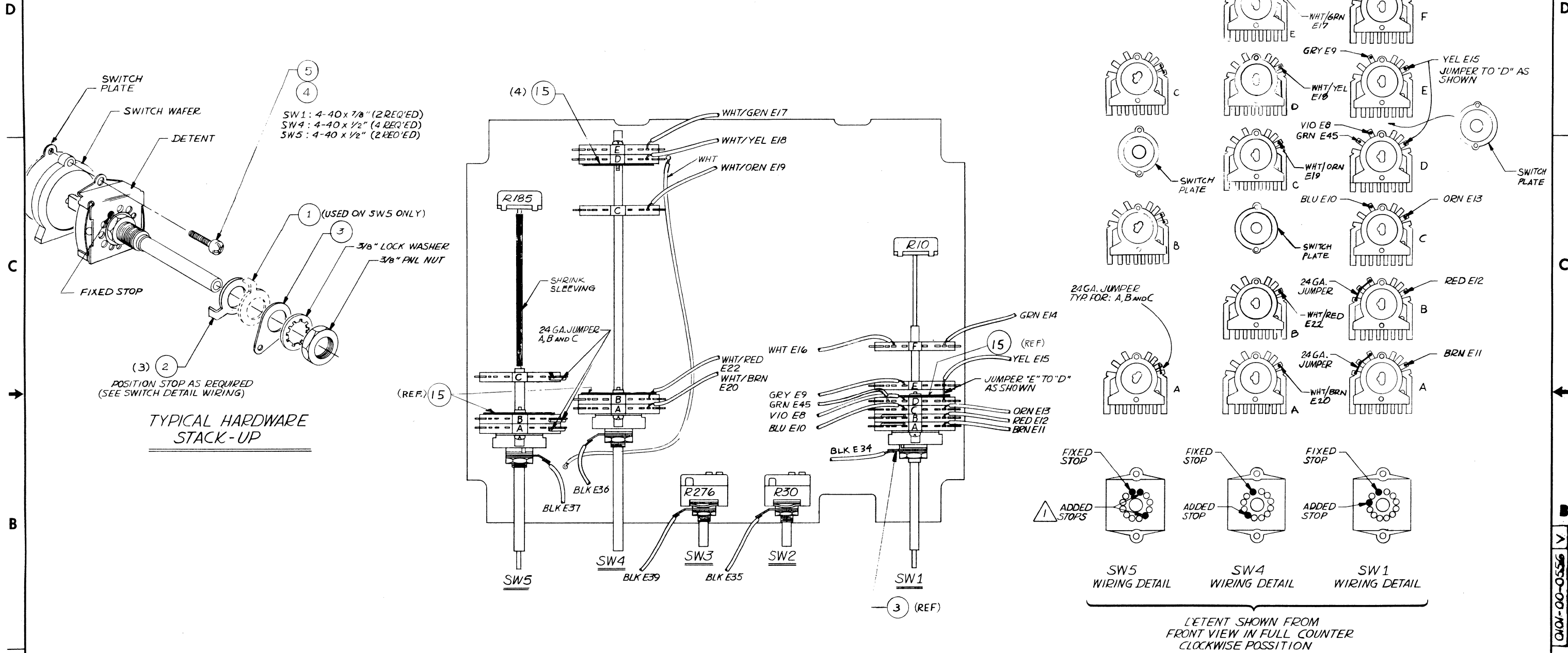

NOTE: UNLESS OTHERWISE SPECIFIED

REMOVE ALL BURRS AND BREAK SHARP EDGES	DRAWN D. COOPER	DATE 1/26/77	WAVETEK SAN DIEGO • CALIFORNIA	
MATERIAL #	PROJ ENGR 15	3/2/77	TITLE ASSEMBLY GENERATOR BOARD	
FINISH WAVETEK PROCESS	RELEASE APPROV		DO NOT SCALE DWG	MODEL NO 145
	TOLERANCE UNLESS OTHERWISE SPECIFIED XXX - .010 XX - .030		SCALE	DWG NO 0101-00-0556
				REV V
			CODE IDENT 23338	SHEET 2 OF 3

0101-00-0556 V

THIS DOCUMENT CONTAINS PROPRIETARY INFORMATION AND DESIGN RIGHTS BELONGING TO WAVETEK AND MAY NOT BE REPRODUCED FOR ANY REASON EXCEPT CALIBRATION, OPERATION, AND MAINTENANCE WITHOUT WRITTEN AUTHORIZATION.

REV	ECN	BY	DATE	APP
-----	-----	----	------	-----

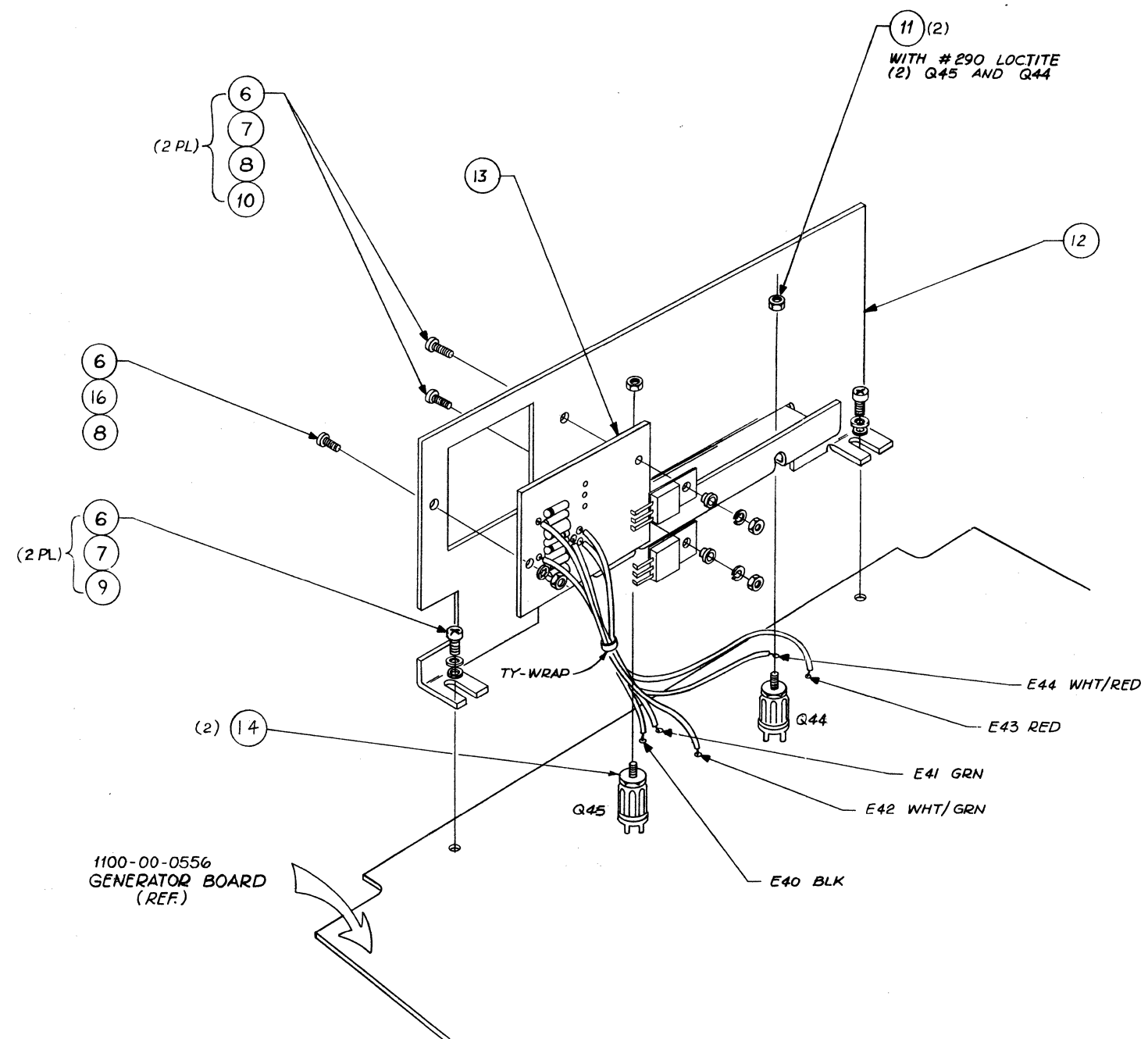

1100-00-0556
GENERATOR BOARD
(REF.)

NOTE: UNLESS OTHERWISE SPECIFIED

REMOVE ALL BURRS AND BREAK SHARP EDGES	DRAWN F.N. AQUINO	DATE 2/10/82	WAVETEK SAN DIEGO • CALIFORNIA	
MATERIAL	PROFENGR		TITLE ASSEMBLY GENERATOR BOARD	
FINISH WAVETEK PROCESS	RELEASE APPROV 3/24/83		MODEL NO 145	DWG NO 0101-00-0556
	TOLERANCE UNLESS OTHERWISE SPECIFIED XXX - 010 ANGLES - 1 XX - 030	DO NOT SCALE DWG	SCALE	REV V
	CODE IDENT 23338	SHEET 3	OF 3	

0101-00-0556 V

THIS DOCUMENT CONTAINS PROPRIETARY INFORMATION AND DESIGN RIGHTS BELONGING TO WAVETEK AND MAY NOT BE REPRODUCED FOR ANY REASON EXCEPT CALIBRATION, OPERATION, AND MAINTENANCE WITHOUT WRITTEN AUTHORIZATION.

REV ECO BY DATE APP

REFERENCE DESIGNATORS	PART DESCRIPTION	DRWG-MFGR-PART-NO	MFGR	WAVETEK NO.	QTY/PT
NONE	ASSY DRWG GENERATOR	0101-00-0556	WVTK	0101-00-0556	1
NONE	SCHEMATIC GENERATOR	0103-00-0556	WVTK	0103-00-0556	1
13	PCA, CURRENT LIMITER	143-100B	WVTK	1208-00-100B	1
NONE	KIT, PRE WAVE LOAD 145-0556	145-1563	WVTK	1208-00-1563	1
C49	CAP, CER, 56PF, 1KV	DD-560	CRL	1500-05-6001	1
C37 38 39	CAP SET, POLYCY MIXED MATCHED SET	1509-80-000B	BISHO	1509-80-000B	1
J1	CONN, 9PIN	09-60-1091	MOLEX	2100-02-0052	1
NONE	SOCKET, MINISERT	75060-012	BERG	2100-03-0076	4
NONE	KNOB STD	RB-67-1-SB-M	ROGAN	2400-01-0008	3
NONE	COAX KNOB SET	RB-67-1-SB+O-M-9	ROGAN	2400-01-0009	2
NONE	SUPER KIT	2500-0145-01	WVTK	2500-0145-01	1
NONE	HEAT SINK	207	WAKE	2800-11-0001	2
NONE	TRANSIPAD	531-218	BIVAR	2800-11-0004	2
14	HEATSINK	2606SH5E	WAKE	2800-11-0012	2
11	NUT, MACHINE SCREW, 18-8 SS, #6-32 SMALL PATTERN	NAS 671C6	CHMCL	2800-50-6100	2

WAVETEK PARTS LIST
TITLE: PCA, GENERATOR
ASSEMBLY NO. 1100-00-0556
PAGE 1
REV AC

REFERENCE DESIGNATORS	PART DESCRIPTION	DRWG-MFGR-PART-NO	MFGR	WAVETEK NO.	QTY/PT
NONE	ASSY DRWG, CURRENT LIMITER BOARD	0101-00-100B	WVTK	0101-00-100B	1
NONE	SCHEMATIC GENERATOR	0103-00-0556	WVTK	0103-00-0556	1
12	HEATSINK BRACKET	143-50B3	WVTK	1400-01-50B3	1
NONE	CURRENT LIMITER BD REF: SPEC 0008-00-0455 REV C	143-100B	WVTK	1700-00-100B	1
10	WASHER	5607-150	SESTM	2800-11-0015	2
7	WASHER, LOCK REQ, S/S #4	MS 3533B-135	CHMCL	2800-45-4000	2
16	LOCK WASHER, INTERNAL TOOTH, SS #4	MS 35333-70	CHMCL	2800-45-4001	1
6	SCREW PLPS PAN M/S 18-8 S/S 4-40X3/8	MS 51957-15	CHMCL	2800-48-4106	3
8	NUT, MACHINE SCREW, 18-8 SS, #4-40	NAS 671C4	CHMCL	2800-50-4100	3
R285 R287	RES, C, 1/2W, 5%, 4.7	RC-1/2-4R7J	STKPL	4700-25-0479	2
R284 R286	RES, MF, 1/8W, 1%, 100	RN55D-1000F	TRW	4701-03-1000	2
CR47 CR48 CR49 CR50	DIODE, ZENER, 10V	1N758A	FAIR	4801-01-0758	4
U13	VOLT REGULATOR, 3 TERMINAL ADJUSTABLE	LM317T	NSC	7000-03-1700	1

WAVETEK PARTS LIST
TITLE: PCA, CURRENT LIMITER
ASSEMBLY NO. 1208-00-100B
PAGE 1
REV B

REFERENCE DESIGNATORS	PART DESCRIPTION	DRWG-MFGR-PART-NO	MFGR	WAVETEK NO.	QTY/PT
NONE	ASSY DRWG GENERATOR	0101-00-0556	WVTK	0101-00-0556	1
NONE	SCHEMATIC GENERATOR	0103-00-0556	WVTK	0103-00-0556	1
NONE	PC BD PREPPED 145-0556	145-1564	WVTK	1208-00-1564	1
C55	CAP, CER, 5PF, 1KV	DD-050 LONG LEAD	CRL	1500-00-5001	1
C10BT C61 C76 C77	CAP, CER DISK, 5PF, 1KV, 10%	0311-0001B	WVTK	1500-00-5011	4
C59 C82	CAP, CER, 10PF, 1KV	DD-100	CRL	1500-01-0011	2
C102 C87	CAP, CER, 100PF, 1KV	DD-101	CRL	1500-01-0111	2
C13 C22 C9	CAP, CER, .001UF, 1KV	DD-102	CRL	1500-01-0211	3
C1 C101 C103 C104 C11 C110 C16 C17 C18 C20 C21 C24 C27 C29 C3 C30 C32 C33 C4 C42 C43 C44 C5 C53 C54 C56 C57 C58 C60 C62 C63 C66 C68 C71 C72 C73 C74 C75 C80 C81 C83 C84 C89 C90 C92	CAP, CER MON, .01MF 50V, AXIAL	CAC0225U103Z100A	CORNG	1500-01-0310	45
C105 C106 C107 C109 C67 C78 C79 C85 C86 C88 C91 C93 C94	CAP, CER, MON, .1MF, 50V, AXIAL	CAC0325U104Z050A	CORNG	1500-01-0405	13
C2	CAP, CER, 150PF, 1KV	DD-151	CRL	1500-01-5111	1
C10 C14	CAP, CER, 330PF, 1KV	DD-331	CRL	1500-03-3111	2

WAVETEK PARTS LIST
TITLE: KIT, PRE WAVE LOAD 145-0556
ASSEMBLY NO. 1208-00-1563
PAGE 1
REV AB

REFERENCE DESIGNATORS	PART DESCRIPTION	DRWG-MFGR-PART-NO	MFGR	WAVETEK NO.	QTY/PT
Q44	TRANS	2N3866	MOT	4901-03-8660	1
Q45	TRANS	2N5160-1B	MOT	4901-05-1600	1

WAVETEK PARTS LIST
TITLE: PCA, GENERATOR
ASSEMBLY NO. 1100-00-0556
PAGE 2
REV AC

REFERENCE DESIGNATORS	PART DESCRIPTION	DRWG-MFGR-PART-NO	MFGR	WAVETEK NO.	QTY/PT
U12	VOLT REGULATOR	LM337T	NSC	7000-03-3700	1

WAVETEK PARTS LIST
TITLE: PCA, CURRENT LIMITER
ASSEMBLY NO. 1208-00-100B
PAGE 2
REV B

REFERENCE DESIGNATORS	PART DESCRIPTION	DRWG-MFGR-PART-NO	MFGR	WAVETEK NO.	QTY/PT
C26	CAP, MICA, 100PF, 500V	DM15-101J	ARCO	1500-11-0100	1
C25	CAP, MICA, 15PF, 500V	DM15-150J	ARCO	1500-11-5000	1
C28 C31 C99T	CAP, MICA, 220PF, 500V, RADIAL	DM15-221J	ARCO	1500-12-2100	3
NONE	CAP, MICA, 30PF, 500V, RADIAL	DM15-300J	ARCO	1500-13-0000	1
C46 C51	CAP, MICA, 47PF, 500V	DM15-470J	ARCO	1500-14-7000	2
C47 C50 NONE	CAP, MICA, 68PF, 500V	DM15-680J	ARCO	1500-16-8000	3
C36	CAP, MICA, 820PF, 300V	DM15-821F	ARCO	1500-18-2101	1
C69	CAP, ELECT, 22MF, 25V, RADIAL	SRA25VB22RM6X7LL	UNCON	1500-32-2002	1
C19	CAP, POLYCY, 1MF, 100V, AXIAL	B1A105F	ELPAC	1500-41-0504	1
C34 C40	CAP, VAR, 3.5-13PF, 250V	78-TRIKD-02 3.5/13PF	TRIKD	1500-51-3000	2
C12 C8 C96 C97	CAP, TANT, 1MF, 35V	150D105X9035A2	SPRAG	1500-71-0502	4
C95 C98	CAP, TANT 27UF, 35V+/-10%, 0.25LS	199D276X9035FE4	SPRAG	1500-72-7602	2
C111 C112 C64 C65	CAP, TANT, 5.6MF, 35V	150D565X9035B2	SPRAG	1500-75-6502	4
NONE	TRANSIPAD	10123N	METRS	2800-11-0003	2

WAVETEK PARTS LIST
TITLE: KIT, PRE WAVE LOAD 145-0556
ASSEMBLY NO. 1208-00-1563
PAGE 2
REV AB

NOTE: UNLESS OTHERWISE SPECIFIED

REMOVE ALL BURRS AND BREAK SHARP EDGES	DRAWN	DATE	
MATERIAL	CHECKED		
FINISH: WAVETEK PROCESS	PROJ. ENGR.		
	RELEASE APPROV.		
UNLESS OTHERWISE SPECIFIED DIMENSIONS ARE IN INCHES TOLERANCES ARE: FRACTIONS DECIMALS ANGLES			TITLE PARTS LIST PCA, GENERATOR
DO NOT SCALE DRAWING	SIZE: D	SCALE: MODEL 145	
	DWG. NO. 23338	DWG. NO. 1100-00-0556	REV AC
		SHEET 1	OF 3

118888
 THIS DOCUMENT CONTAINS PROPRIETARY INFORMATION AND DESIGN RIGHTS BELONGING TO WAVETEK AND MAY NOT BE REPRODUCED FOR ANY REASON EXCEPT CALIBRATION, OPERATION, AND MAINTENANCE WITHOUT WRITTEN AUTHORIZATION.

REV ECO BY DATE APP

REFERENCE DESIGNATORS	PART DESCRIPTION	ORIG-MFG-PART-NO	MFG	WAVETEK NO.	QTY/PT
NONE	TRANSIPAD	531-218	BIVAR	2800-11-0004	2
FB1	FERRITE BEAD	56-590-65/38	FERRX	3100-00-0001	1
R4 R48	POT, TRIM, 1K	91AR1K	BECK	4600-01-0209	2
R12 R162 R55	POT, TRIM, 10K	91AR10K	BECK	4600-01-0315	3
R13 R16 R181 R252	POT, TRIM, 100K	91AR100K	BECK	4600-01-0402	4
R120	POT, TRIM, 200	91AR200	BECK	4600-02-0101	1
R107 R35 R93	POT, TRIM, 500	91AR500	BECK	4600-05-0104	3
R11 RB	RES. C, 1/2W, 10%, 5. 1M	RC-1/2-515J	STKPL	4700-25-5104	2
R17	RES. C, 1/2W, 10%, 6. 8M			4700-25-6804	1
R118 R124 R127 R128 R129 R142 R145 R149 R153 R158 R174 R180 R214 R216 R49 R57 R73	RES. MF, 1/BW, 1%, 100	RN55D-1000F	TRW	4701-03-1000	17
R104 R108 R111 R155 R165 R168 R200 R237 R45 R47 R51 R94 R98 R99	RES. MF, 1/BW, 1%, 1K	RN55D-1001F	TRW	4701-03-1001	14
R112 R146 R203 R265 R41	RES. MF, 1/BW, 1%, 10K	RN55D-1002F	TRW	4701-03-1002	5
R116 R123 R139 R141 R172 R173 R196 R210 R236T R24 R273 R38 R50 R61 R64 R74	RES. MF, 1/BW, 1%, 10	5043ED10R100F	MEPCO	4701-03-1009	18

WAVETEK PARTS LIST
 TITLE KIT, PRE WAVE LOAD 145-0556
 ASSEMBLY NO. 1208-00-1563
 PAGE 3
 REV AB

REFERENCE DESIGNATORS	PART DESCRIPTION	ORIG-MFG-PART-NO	MFG	WAVETEK NO.	QTY/PT
R237 R248	RES. MF, 1/BW, 1%, 23. 7K	RN55D-2372F	TRW	4701-03-2372	2
R102 R137 R144 R159 R186 R230 R242 R245 R25 R262 R39	RES. MF, 1/BW, 1%, 249	RN55D-2490F	TRW	4701-03-2490	11
R147 R151 R156 R171 R198 R189 R19 R254 R255 R274 R278 R33	RES. MF, 1/BW, 1%, 2. 49K	RN55D-2491F	TRW	4701-03-2491	12
R161 R213 R281 R283	RES. MF, 1/BW, 1%, 24. 9K	RN55D-2492F	TRW	4701-03-2492	4
R187T	RES. MF, 1/BW, 1%, 27. 4	RN55D-27R4F	TRW	4701-03-2749	1
R150 R177 R178 R43	RES. MF, 1/BW, 1%, 3. 01K	RN55D-3011F	TRW	4701-03-3011	4
R131 R256	RES. MF, 1/BW, 1%, 301K	RN55D-3013F	TRW	4701-03-3013	2
R134 R67 R71 R88 R89	RES. MF, 1/BW, 1%, 316	RN55D-3160F	TRW	4701-03-3160	5
R101 R103 R109 R110 R119 R126 R130 R140 R192 R204 R253 R269 R272 R65 R68 R69 R72 R75 R76 R79 R82 R95	RES. MF, 1/BW, 1%, 33. 2	RN55D-33R2F	TRW	4701-03-3329	22
R100T R105T	RES. MF, 1/BW, 1%, 3. 57K	RN55D-3571F	TRW	4701-03-3571	2
R191 R202 R298 R80 R83	RES. MF, 1/BW, 1%, 3. 65K	RN55D-3651F	TRW	4701-03-3651	5
R115 R193 R194 R195	RES. MF, 1/BW, 1%, 392	RN55D-3920F	TRW	4701-03-3920	4
R199 R42	RES. MF, 1/BW, 1%, 4. 02K	RN55D-4021F	TRW	4701-03-4021	2
R106 R205 R206 R207	RES. MF, 1/BW, 1%, 464	RN55D-4640F	TRW	4701-03-4640	4

WAVETEK PARTS LIST
 TITLE KIT, PRE WAVE LOAD 145-0556
 ASSEMBLY NO. 1208-00-1563
 PAGE 5
 REV AB

REFERENCE DESIGNATORS	PART DESCRIPTION	ORIG-MFG-PART-NO	MFG	WAVETEK NO.	QTY/PT
R154	RES. MF, 1/BW, 1%, 76. 8K	RN55D-7682F	TRW	4701-03-7682	1
R125	RES. MF, 1/BW, 1%, 825	RN55D-8250F	TRW	4701-03-8250	1
R238 R249 R58	RES. MF, 1/BW, 1%, 8. 25K	RN55D-8251F	TRW	4701-03-8251	3
R197T R208T R59	RES. MF, 1/BW, 1%, 82. 5	RN55D-82R5F	TRW	4701-03-8259	3
R122 R228	RES. MF, 1/BW, 1%, 909	RN55D-9090F	TRW	4701-03-9090	2
R271	RES. MF, 1/BW, 1%, 90. 9	RN55D-90R9F	TRW	4701-03-9099	1
R7	RES. MF, 1/4W, 1%, 1M	RN60D-1004F	TRW	4701-13-1004	1
R233	RES. MF, 1/4W, 1%, 121	RN60D-1210F	TRW	4701-13-1210	1
R229	RES. MF, 1/4W, 1%, 124	RN60D-1240F	TRW	4701-13-1240	1
R175	RES. MF, 1/4W, 1%, 49. 9	RN60D-49R9F	TRW	4701-13-4999	1
R6T	RES. MF, 1/4W, 1%, 698K	RN60D-6983F	TRW	4701-13-6983	1
R224 R225 R226 R227	RES. MF, 1/2W, 1%, 49. 9	RN65D-49R9F	TRW	4701-23-4999	4
R52 R53 R54	RES. MF, MIXED SET	4789-00-0043	IRC	4789-00-0043	1
R56	RES. MF, .6M, 1%, 10M	ML-181	CADDD	4799-00-0003	1
17	RES. 0 OHM JUMPER	JPO2T68Q	ROHM	4799-00-0087	9
CR3 CR33 CR4 CR5	DIODE, ZENER, 6. 2V, 1N823	1N823A	MOT	4801-01-0823	4

WAVETEK PARTS LIST
 TITLE KIT, PRE WAVE LOAD 145-0556
 ASSEMBLY NO. 1208-00-1563
 PAGE 7
 REV AB

REFERENCE DESIGNATORS	PART DESCRIPTION	ORIG-MFG-PART-NO	MFG	WAVETEK NO.	QTY/PT
R81 R84	RES. MF, 1/BW, 1%, 1. 1K	RN55D-1101F	TRW	4701-03-1101	2
R211 R212	RES. MF, 1/BW, 1%, 11K	RN55D-1102F	TRW	4701-03-1102	4
R239 R240 R250 R251	RES. MF, 1/BW, 1%, 1. 21K	RN55D-1211F	TRW	4701-03-1211	2
R96 R97	RES. MF, 1/BW, 1%, 150	RN55D-1500F	TRW	4701-03-1500	4
R114 R241 R247 R66	RES. MF, 1/BW, 1%, 1. 5K	RN55D-1501F	TRW	4701-03-1501	11
R113 R176 R18 R198 R23 R267 R32 R36 R62 R63 R9	RES. MF, 1/BW, 1%, 15K	RN55D-1502F	TRW	4701-03-1502	3
R132 R163 R2	RES. MF, 1/BW, 1%, 150K	RN55D-1503F	TRW	4701-03-1503	1
R182	RES. MF, 1/BW, 1%, 15	RN55D-150R0F	TRW	4701-03-1509	4
R218 R219 R220 R221	RES. MF, 1/BW, 1%, 17. 4K	RN55D-1742F	TRW	4701-03-1742	1
R263T	RES. MF, 1/BW, 1%, 1. 78K	RN55D-1781F	TRW	4701-03-1781	1
R169	RES. MF, 1/BW, 1%, 1. 96K	RN55D-1961F	TRW	4701-03-1961	1
R184	RES. MF, 1/BW, 1%, 200	RN55D-2000F	TRW	4701-03-2000	1
R179	RES. MF, 1/BW, 1%, 2K	RN55D-2001F	TRW	4701-03-2001	5
R1 R15 R183 R209 R31	RES. MF, 1/BW, 1%, 215	RN55D-2150F	TRW	4701-03-2150	1
R143	RES. MF, 1/BW, 1%, 21. 5	RN55D-21R5F	TRW	4701-03-2159	2
R166 R170	RES. MF, 1/BW, 1%, 46. 4K	RN55D-4642F	TRW	4701-03-4642	1
R5	RES. MF, 1. 8W, 1%, 46. 4	RN55D-46R4F	TRW	4701-03-4649	1
R34	RES. MF, 1/BW, 1%, 4. 75K	RN55D-4751F	TRW	4701-03-4751	1
R231 R259	RES. MF, 1/B, 1%, 499	RN55D-4990F	TRW	4701-03-4990	2
R117 R14 R152 R20 R22 R232 R3 R37	RES. MF, 1/BW, 1%, 4. 99K	RN55D-4991F	TRW	4701-03-4991	8
R157	RES. MF, 1/BW, 1%, 49. 9K	RN55D-4992F	TRW	4701-03-4992	1
R85T R92T	RES. MF, 1/BW, 1%, 54. 9	RN55D-54R9F	TRW	4701-03-5499	2
R235	RES. MF, 1/BW, 1%, 56. 2	RN55D-56R2F	TRW	4701-03-5629	1
R148T R243 R246	RES. MF, 1/BW, 1%, 576	RN55D-5760F	TRW	4701-03-5760	3
R21 R40 R44 R86 R91	RES. MF, 1/BW, 1%, 604	RN55D-6040F	TRW	4701-03-6040	5
R215 R217 R234 R244 R260 R268 R275	RES. MF, 1/BW, 1%, 61. 9	RN55D-61R9F	TRW	4701-03-6199	7
R264 R270	RES. MF, 1/BW, 1%, 681	RN55D-6810F	TRW	4701-03-6810	2
R46	RES. MF, 1/BW, 1%, 6. 98K	RN55D-6981F	TRW	4701-03-6981	1
R135 R167 R190 R60 R70	RES. MF, 1/BW, 1%, 750	RN55D-7500F	TRW	4701-03-7500	5
R133 R136 R138 R160 R164 R261 R266 R77 R78	RES. MF, 1/BW, 1%, 7. 5K	RN55D-7501F	TRW	4701-03-7501	9

WAVETEK PARTS LIST
 TITLE KIT, PRE WAVE LOAD 145-0556
 ASSEMBLY NO. 1208-00-1563
 PAGE 4
 REV AB

REFERENCE DESIGNATORS	PART DESCRIPTION	ORIG-MFG-PART-NO	MFG	WAVETEK NO.	QTY/PT
CR16	DIODE, REFERENCE, LOW LEVEL, TEMP COMP	1N4581	MICRO	4801-01-4581	1
CR19 CR28 CR29 CR30 CR31 CR6 CR7 CR8 CR9	DIODE, ULTRA FAST	1N4244	T/CBSF	4807-02-0777	9
CR1 CR10 CR11 CR14 CR15 CR17 CR18 CR20 CR21 CR22 CR23 CR24 CR25 CR27 CR32 CR34 CR35 CR36 CR37 CR46	DIODE 1N4148 COMPUTER, Q/P, 75V, 200M A, SWITCHING	1N4148	FAIR	4807-02-6666	20
CR12 CR13	DIODE 5082-2811 SCHOTTKY, 15V, 20MA	5082-2811	HP	4809-02-2811	2
CR2 26	DIODE, M/PR, FD-777 QTY: 2: 4807-02-0777	4898-00-0004	KLQ	4898-00-0004	1
CR38 39 40 41 42 43 44 45	DIODE, SET, 8-FD-777 QTY: 8: 4807-02-0777	4898-00-0010	KLQ	4898-00-0010	1
Q42	TRANS 2N2219A NPN GENERAL PURPOSE TO-5	2N2219A	NSC	4901-02-2191	1
Q43	TRANS 2N2905A PNP GENERAL PURPOSE TO-5	2N2905A	NSC	4901-02-9051	1
Q12 Q36 Q50	TRANS. NPN, TO-92	2N3563	FAIR	4901-03-5630	3
Q15 Q16 Q37 Q49	TRANS. PNP, TO-92	MPS3640	MOT	4901-03-6400	4
Q39	TRANS	2N3866	MOT	4901-03-8660	1

WAVETEK PARTS LIST
 TITLE KIT, PRE WAVE LOAD 145-0556
 ASSEMBLY NO. 1208-00-1563
 PAGE 8
 REV AB

NOTE: UNLESS OTHERWISE SPECIFIED

REMOVE ALL BURRS AND BREAK SHARP EDGES	DRAWN	DATE	
MATERIAL	CHECKED		
	PROJ. ENGR.		
	RELEASE APPROV.		
FINISH WAVETEK PROCESS	UNLESS OTHERWISE SPECIFIED DIMENSIONS ARE IN INCHES TOLERANCES ARE: FRACTIONS DECIMALS ANGLES		TITLE PARTS LIST PCA, GENERATOR
DO NOT SCALE DRAWING	SCALE	SIZE D 23338 FSCM NO. 1100-00-0556 DWG. NO. AC MODEL 145 SHEET 2 OF 3	

THIS DOCUMENT CONTAINS PROPRIETARY INFORMATION AND DESIGN RIGHTS BELONGING TO WAVETEK AND MAY NOT BE REPRODUCED FOR ANY REASON EXCEPT CALIBRATION, OPERATION, AND MAINTENANCE WITHOUT WRITTEN AUTHORIZATION.

REV ECO BY DATE APP

REFERENCE DESIGNATORS	PART DESCRIPTION	ORIG-MFGR-PART-NO	MFGR	WAVETEK NO.	QTY/PT
Q13 Q21 Q22 Q25 Q27 Q28 Q29 Q31 Q40 Q6	TRANS. GENERAL PURPOSE, NPN, TO-92	2N3903	NSC	4901-03-9030	10
Q10 Q11 Q14 Q17 Q19 Q23 Q24 Q26 Q30 Q32 Q33 Q34 Q4 Q41 Q46 Q47 Q51	TRANS. GENERAL PURPOSE, PNP, TO-92	2N3905	ITT	4901-03-9050	17
Q38	TRANS	2N5160-1B	MOT	4901-05-1600	1
Q3	TRANS, P-CHANNEL JFETS	2N5460	MOT	4901-05-4600	1
Q5	TRANS, N-CHANNEL JFETS	2N5485	MOT	4901-05-4850	1
Q1	TRANS N-CHANNEL JFETS	2N5486	MOT	4901-05-4860	1
Q18 20	TRANS, M/PR, 2N3563 QTY: 2: 4901-03-5630	4998-00-0004	KLG	4998-00-0004	1
Q2 Q7	TRANS, SEL, 2N5462 QTY: 1: 4901-05-4620	4998-00-0008	KLG	4998-00-0008	2
Q8 9	TRANS, M/PR, 2N5485 QTY: 2: 4901-05-4850	4998-00-0009	KLG	4998-00-0009	1
IC4 IC5	DP AMP, LOWOFFSET/DRIFT JFET INPUT TIONAL AMPLI	LF411CN	NSC	7000-04-1100	2
Q35 Q48	TRANS, MOND, DUAL, NPN	LS312-52	LINSY	7000-08-1200	2
IC1 IC2 IC6	DP AMP, DUAL, HIGH GAIN, INTERNALLY COMP	MC1458P1	MOT	7000-14-5800	3

WAVETEK
PARTS LIST

TITLE
KIT, PRE WAVE LOAD 145-0556

ASSEMBLY NO. 1208-00-1563

PAGE 9

REV
AB

REFERENCE DESIGNATORS	PART DESCRIPTION	ORIG-MFGR-PART-NO	MFGR	WAVETEK NO.	QTY/PT
NONE	ASSY, SWITCH SW-1 145-0556	145-1565	WVTK	1202-00-1565	1
NONE	ASSY, SWITCH SW-2 145-0556	145-1566	WVTK	1202-00-1566	1
NONE	ASSY, SWITCH SW-3 145-0556	145-1567	WVTK	1202-00-1567	1
NONE	ASSY, SWITCH SW-4 145-0556	145-1568	WVTK	1202-00-1568	1
NONE	ASSY, SWITCH SW-5 145-0556	145-1569	WVTK	1202-00-1569	1

WAVETEK
PARTS LIST

TITLE
SUPER KIT

ASSEMBLY NO. 2500-0145-01

PAGE 1

REV

REFERENCE DESIGNATORS	PART DESCRIPTION	ORIG-MFGR-PART-NO	MFGR	WAVETEK NO.	QTY/PT
IC9	DIFFERENTIAL AMP, DUAL HIGH FREQ	CA3049T	RCA	7000-30-4900	1
IC7 IC8	DP AMP, BIMOS MOSFET INPUT/BIPOLAR OUTPUT	CA3140S	RCA	7000-31-4001	2

WAVETEK
PARTS LIST

TITLE
KIT, PRE WAVE LOAD 145-0556

ASSEMBLY NO. 1208-00-1563

PAGE 10

REV
AB

REMOVE ALL BURRS AND BREAK SHARP EDGES	DRAWN	DATE	<p>WAVETEK SAN DIEGO • CALIFORNIA</p> <p>TITLE</p> <p>PARTS LIST PCA, GENERATOR</p>
MATERIAL	CHECKED		
	PROJ. ENGR.		
	RELEASE APPROV.		
FINISH WAVETEK PROCESS	UNLESS OTHERWISE SPECIFIED DIMENSIONS ARE IN INCHES TOLERANCES ARE: FRACTIONS DECIMALS ANGLES ± .XX ± .XXX ± °		<p>SIZE FSCM NO. DWG. NO. REV</p> <p>D 23338 1100-00-0556 AC</p>
DO NOT SCALE DRAWING	SCALE	MODEL 145	SHEET 3 OF 3

NOTE: UNLESS OTHERWISE SPECIFIED

REV	ECN	BY	DATE	APP
A	4938	A.T.	2/24/86	

THIS DOCUMENT CONTAINS PROPRIETARY INFORMATION AND DESIGN RIGHTS BELONGING TO WAVETEK AND MAY NOT BE REPRODUCED FOR ANY REASON EXCEPT CALIBRATION, OPERATION, AND MAINTENANCE WITHOUT WRITTEN AUTHORIZATION.

REFERENCE DESIGNATORS	PART DESCRIPTION	DRG-MFGR-PART-NO	MFGR	WAVETEK NO.	QTY/PT
NONE	ASSY DRWG, CURRENT LIMITER BOARD	0101-00-1008	WVTK	0101-00-1008	1
NONE	SCHEMATIC GENERATOR	0103-00-0556	WVTK	0103-00-0556	1
12	HEATSINK BRACKET	143-5083	WVTK	1400-01-5083	1
NONE	CURRENT LIMITER BD REF. SPEC 0008-00-0455 REV C	143-1008	WVTK	1700-00-1008	1
10	WASHER	5607-150	BESTM	2800-11-0015	2
7	WASHER, LOCK REG. S/S #4	MS 35338-135	CMRCL	2800-45-4000	2
16	LOCK WASHER, INTERNAL TOOTH, SS #4	MS 35333-70	CMRCL	2800-45-4001	1
6	SCREW PLPS PAN M/S 1/8-S S/S 4-40X3/8	MS 51957-15	CMRCL	2800-48-4106	3
8	NUT, MACHINE SCREW, 1/8-S SS, #4-40	NAS 671C4	CMRCL	2800-50-4100	3
R285 R287	RES, C, 1/2W, 5%, 4.7	RC-1/2-4R7J	STKPL	4700-25-0479	2
R284 R286	RES, MF, 1/8W, 1%, 100	RN55D-1000F	TRW	4701-03-1000	2
CR47 CR48 CR49 CR50	DIODE, ZENER, 10V	1N758A	FAIR	4801-01-0758	4
U13	VOLT REGULATOR, 3 TERMINAL ADJUSTABLE	LM317T	NSC	7000-03-1700	1

WAVETEK PARTS LIST TITLE: PCA, CURRENT LIMITER ASSEMBLY NO. 1208-00-1008 REV B
PAGE 1

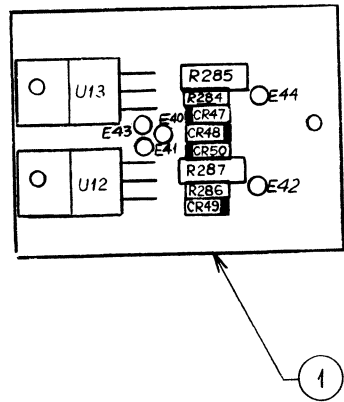

REFERENCE DESIGNATORS	PART DESCRIPTION	DRG-MFGR-PART-NO	MFGR	WAVETEK NO.	QTY/PT
U12	PDS VOLT REGULATOR	LM337T	NSC	7000-03-3700	1

WAVETEK PARTS LIST TITLE: PCA, CURRENT LIMITER ASSEMBLY NO. 1208-00-1008 REV B
PAGE 2

REMOVE ALL BURRS AND BREAK SHARP EDGES	DRAWN <i>RO FIFE</i>	DATE 1/23/83	WAVETEK SAN DIEGO • CALIFORNIA
MATERIAL	PROJ ENGR		
FINISH WAVETEK PROCESS	RELEASE APPROV <i>[Signature]</i>	3/1/83	TITLE ASSEMBLY CURRENT LIMITER BD.
	TOLERANCE UNLESS OTHERWISE SPECIFIED XXX - .010 ANGLES - 1 XX - .030		MODEL NO 145
	DO NOT SCALE DWG	SCALE 2/1	DWG NO 0101-00-1008
			REV A
			CODE IDENT 23338
			SHEET 1 OF 1

1. SEE 0103-00-0556 FOR SCHEMATIC.
NOTE: UNLESS OTHERWISE SPECIFIED

THIS DOCUMENT CONTAINS PROPRIETARY INFORMATION AND DESIGN RIGHTS BELONGING TO WAVETEK AND MAY NOT BE REPRODUCED FOR ANY REASON EXCEPT CALIBRATION, OPERATION, AND MAINTENANCE WITHOUT WRITTEN AUTHORIZATION.

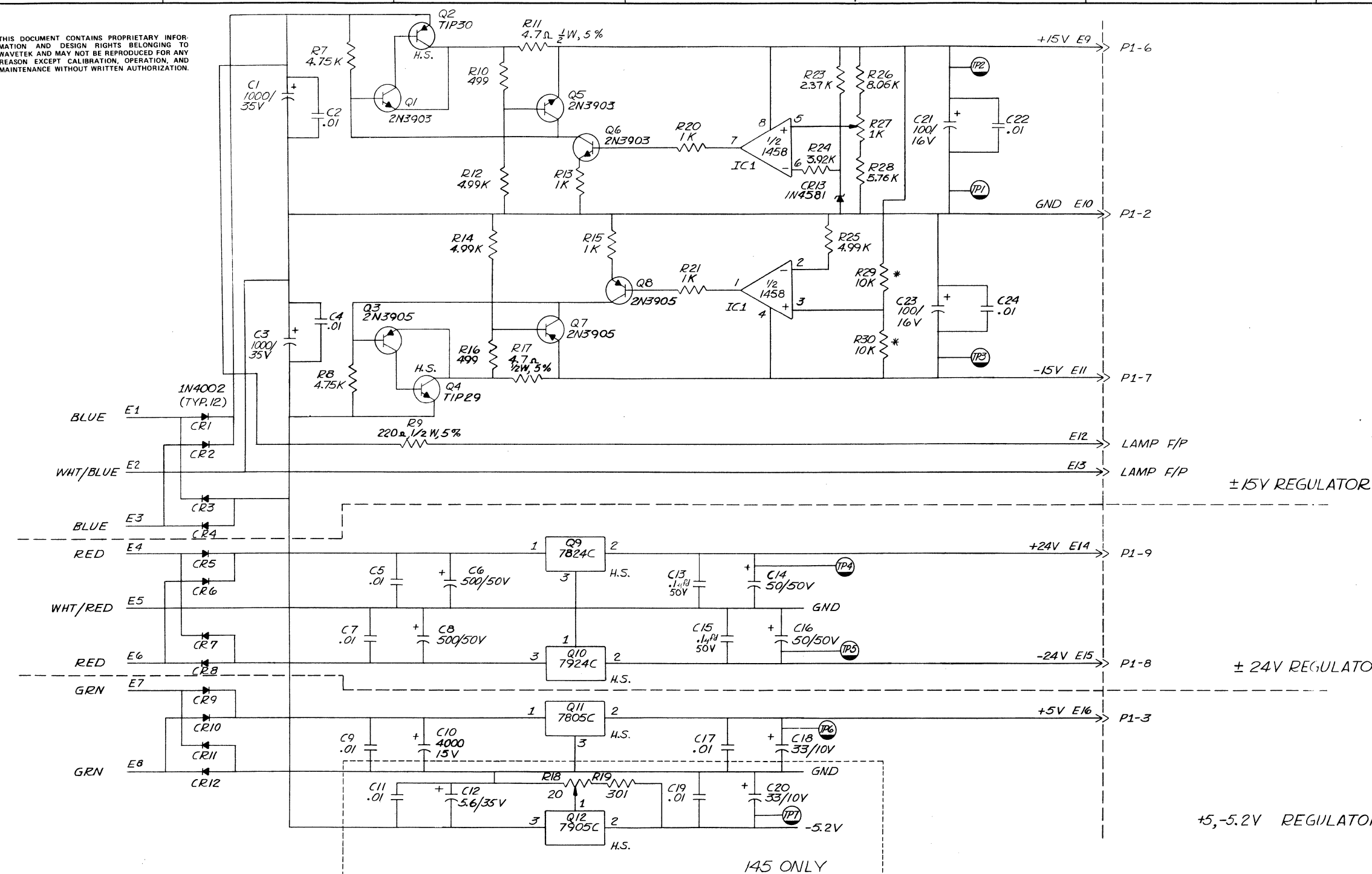

- 4. RESISTORS ARE 1/8W, 1%, M.F
- 3. RESISTANCE IN OHMS
- 2. CAPACITANCE IN MICROFARADS
- 1. * = M.P. 10K RESISTORS

NOTE: UNLESS OTHERWISE SPECIFIED

LAST REF DES USED
 C67
 CR36
 FB9
 IC14
 R72
 SW4
 Q21
 F2

REV	ECN	BY	DATE	APP
B	ECN 1674	RO	8/20/76	
C	ECN 1800	JRM	9-5-8	
D	ECN 2090	DC	12-30	
E	ECN # 412	DC	11-1-80	
F	ECN 2481	LDL	11-1-80	
G	ECN 2801	DC	8-25-80	
H	3195, 3196	JA	9-24-80	
I	3018 (CL II)	JA	9-24-80	
J	ECN 4417	KA	9/16/84	A.R.T.
K	ECN 4674	KA	1/31/85	A.R.T.
L	4664	DAM	7/22/85	A.R.T.
M	7554	HT	7/7/86	A.R.T.
N	89-410	BG	10-24-89	KA

REMOVE ALL BURRS AND BREAK SHARP EDGES	DRAWN D. COOPER	DATE 11-0-76	
MATERIAL	PROJ ENGR V. J. ...	DATE 3-23-77	
FINISH WAVETEK PROCESS	RELEASE APPROV 3-23-77	TOLERANCE UNLESS OTHERWISE SPECIFIED XXX ± 0.10 ANGLES .1 XX ± 0.30	TITLE SCHEMATIC TRIG/PULSE BOARD
SCALE	DO NOT SCALE DWG	MODEL NO. 143/145	DWG NO. 0103-00-0565
		REV N	
		CODE 23338	SHEET 1 OF 2

0103-00-0565

THIS DOCUMENT CONTAINS PROPRIETARY INFORMATION AND DESIGN RIGHTS BELONGING TO WAVETEK AND MAY NOT BE REPRODUCED FOR ANY REASON EXCEPT CALIBRATION, OPERATION, AND MAINTENANCE WITHOUT WRITTEN AUTHORIZATION.

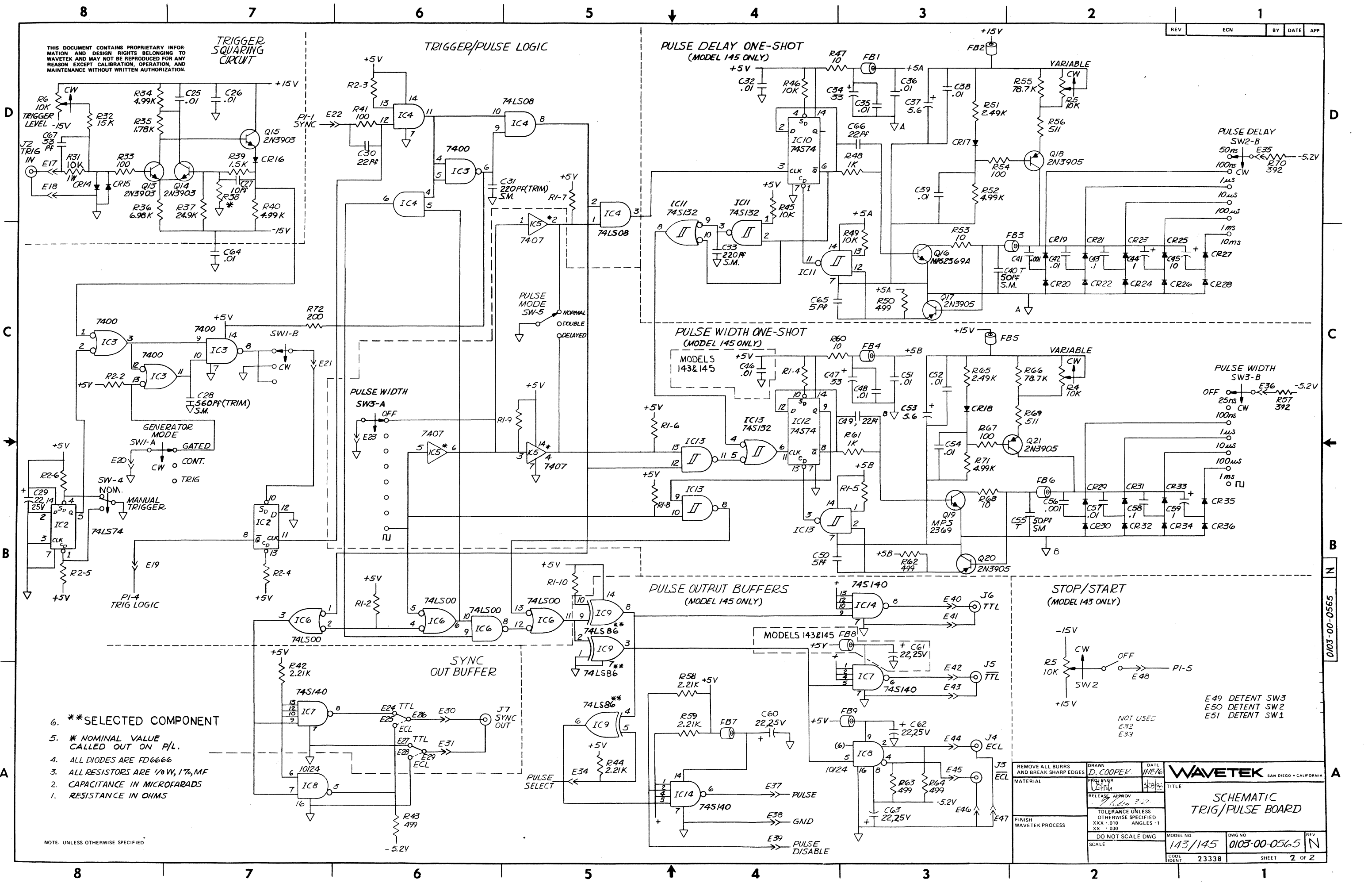

- 6. **SELECTED COMPONENT
- 5. * NOMINAL VALUE CALLED OUT ON P/L.
- 4. ALL DIODES ARE FD6666
- 3. ALL RESISTORS ARE 1/8W, 1%, MF
- 2. CAPACITANCE IN MICROFARADS
- 1. RESISTANCE IN OHMS

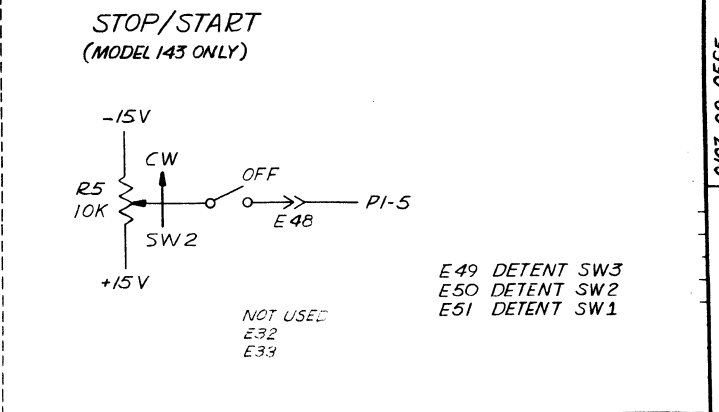

REMOVE ALL BURRS AND BREAK SHARP EDGES MATERIAL		FINISH WAVETEK PROCESS	SCALE
DRAWN D. COOPER	DATE 1/12/76	TOLERANCE UNLESS OTHERWISE SPECIFIED XXX - 010 ANGLES - 1 XX - 030	
TITLE SCHEMATIC TRIG/PULSE BOARD		MODEL NO 143/145	DWG NO 0103-00-0565
DO NOT SCALE DWG		REV N	REV 2 OF 2
CODE IDENT 23338		SHEET 2 OF 2	

E49 DETENT SW3
E50 DETENT SW2
E51 DETENT SW1

NOT USED
E32
E33

NOTE: UNLESS OTHERWISE SPECIFIED

0103-00-0565

THIS DOCUMENT CONTAINS PROPRIETARY INFORMATION AND DESIGN RIGHTS BELONGING TO WAVETEK AND MAY NOT BE REPRODUCED FOR ANY REASON EXCEPT CALIBRATION, OPERATION AND MAINTENANCE WITHOUT WRITTEN AUTHORIZATION

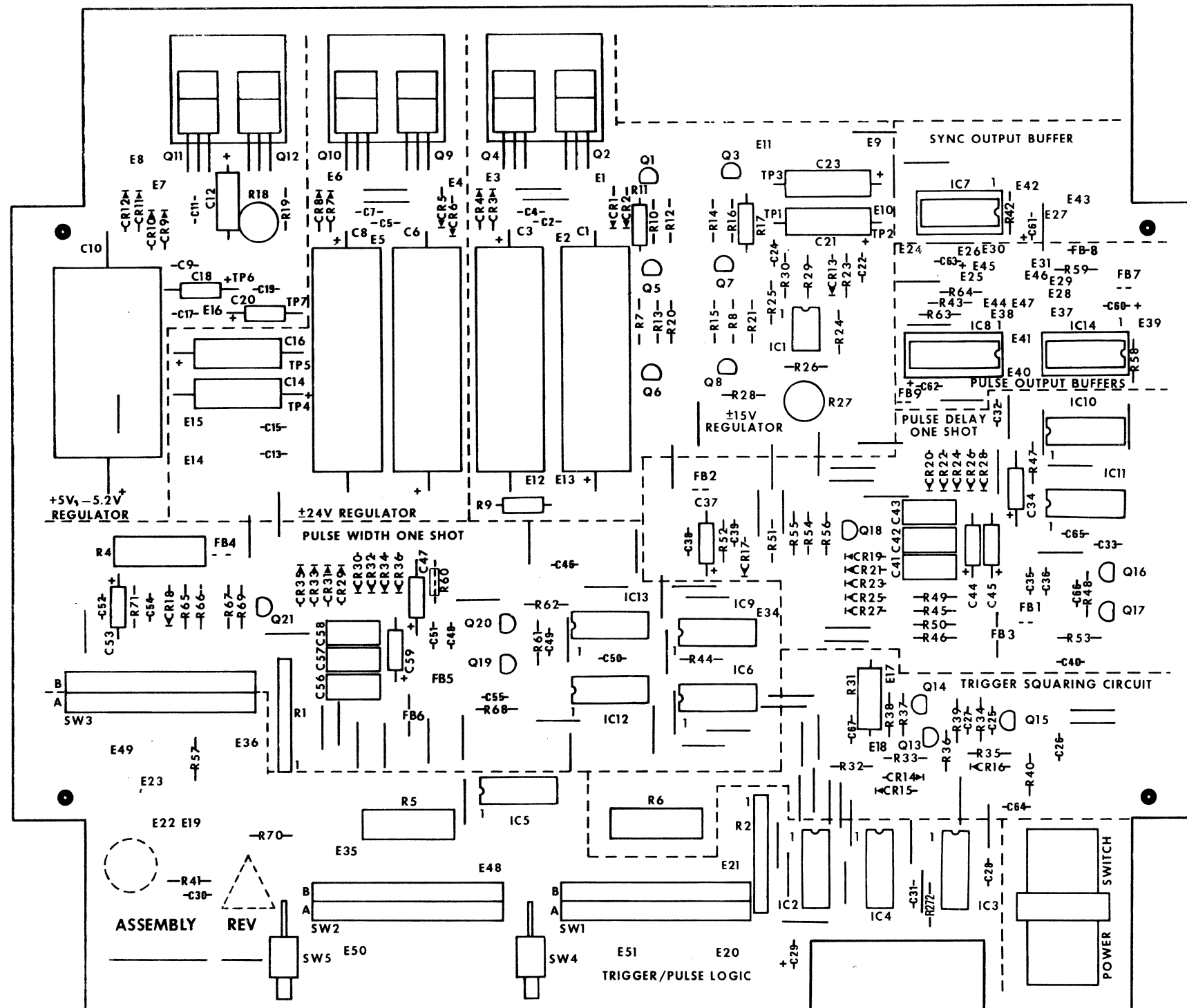

MADE FROM 0100-00-0565-3G

REMOVE ALL BURRS AND BREAK SHARP EDGES	DRAWN	DATE	WAVETEK SAN DIEGO, CALIFORNIA	
MATERIAL	PROJ ENGR		TITLE	
	RELEASE APPROV		PCA, TRIG/PULSE BD	
FINISH WAVETEK PROCESS	TOLERANCE UNLESS OTHERWISE SPECIFIED XXX .010 ANGLES .1 XX .030		MODEL NO	REV
	DO NOT SCALE DWG	SCALE	145	1100-00-0565
			CODE IDENT	SHEET OF
			23338	

8

7

6

5

4

3

2

1

REV ECN BY DATE APP

THIS DOCUMENT CONTAINS PROPRIETARY INFORMATION AND DESIGN RIGHTS BELONGING TO WAVETEK AND MAY NOT BE REPRODUCED FOR ANY REASON EXCEPT CALIBRATION, OPERATION, AND MAINTENANCE WITHOUT WRITTEN AUTHORIZATION.

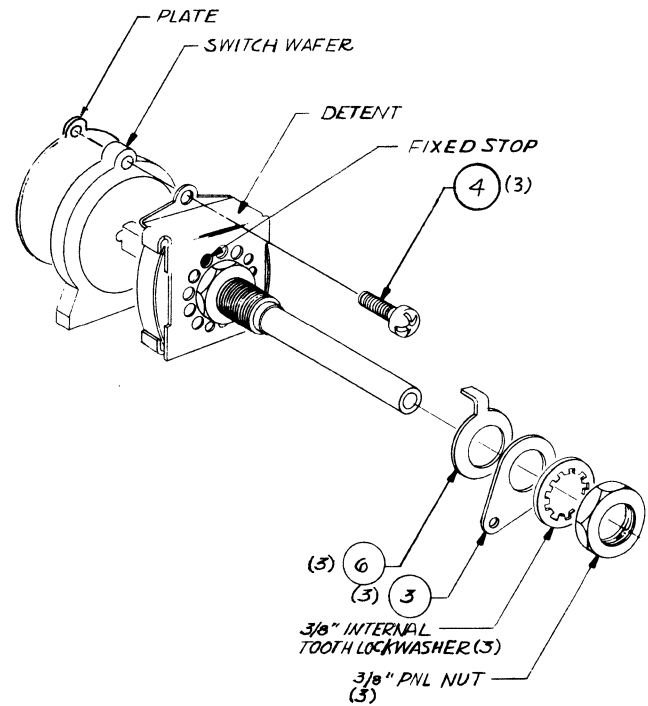

TYPICAL HARDWARE STACK-UP

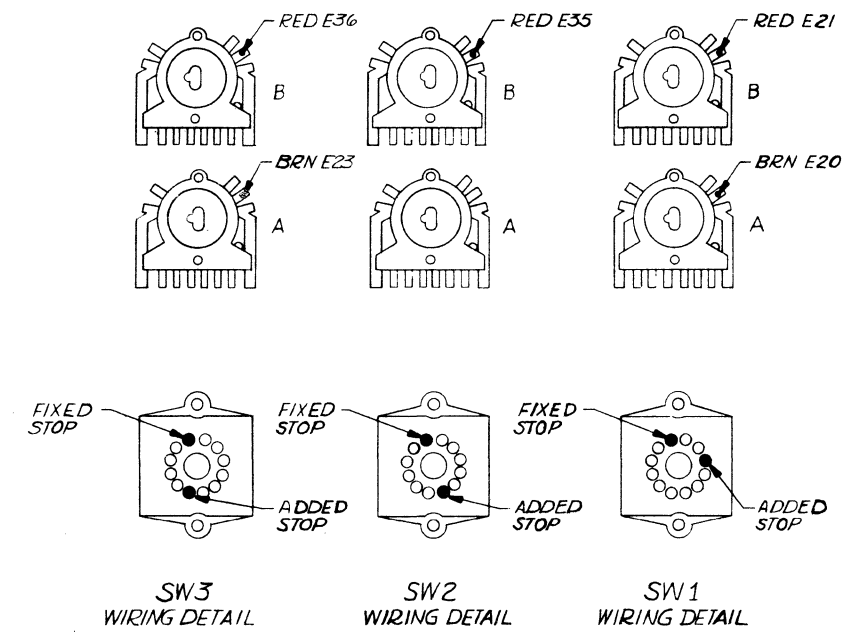
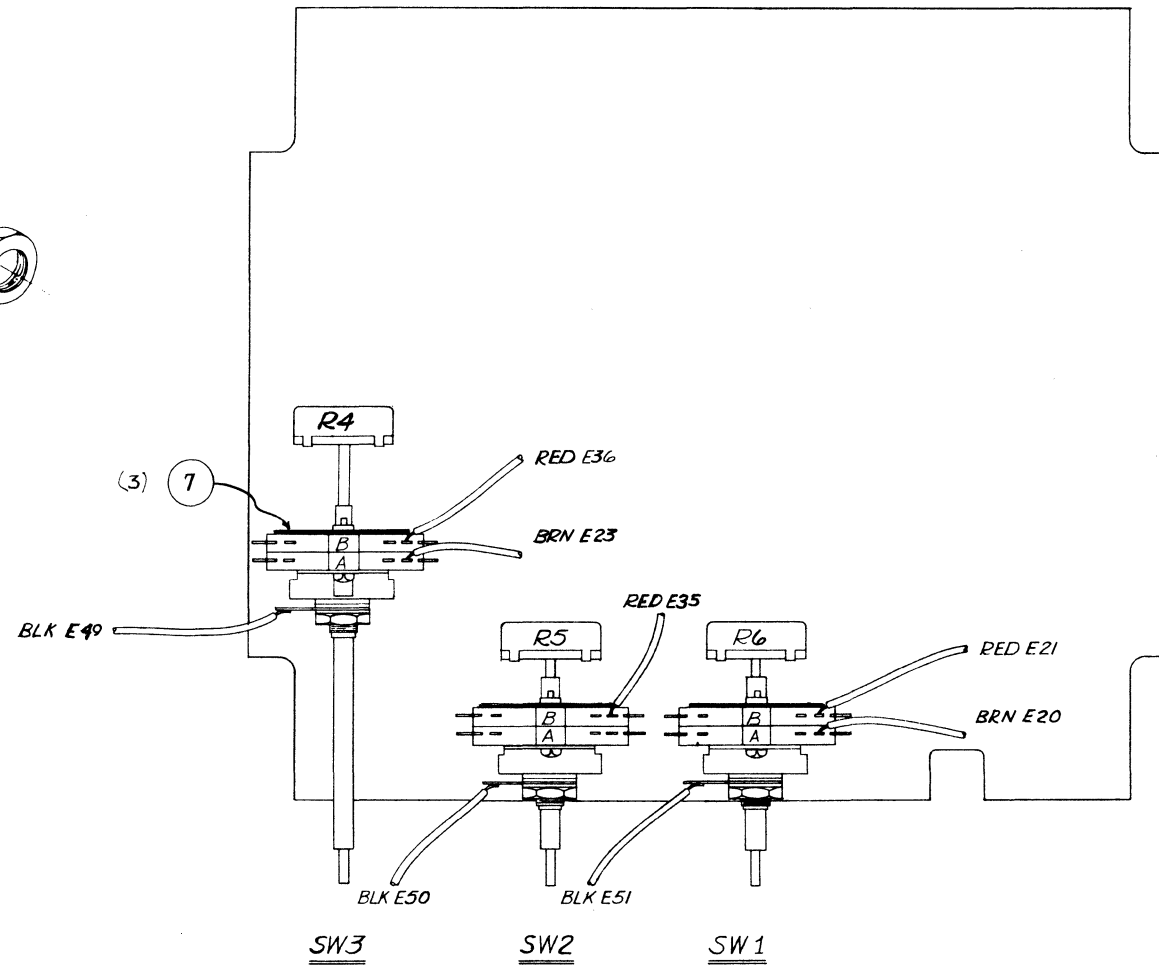

DETENT SHOWN FROM FRONT VIEW IN FULL COUNTER CLOCKWISE POSITION

NOTE: UNLESS OTHERWISE SPECIFIED

REMOVE ALL BURRS AND BREAK SHARP EDGES	DRAWN <i>D. COOPER</i>	DATE 12/77	WAVETEK SAN DIEGO • CALIFORNIA	
MATERIAL	PROJ ENGR		TITLE ASSEMBLY TRIG/PULSE BD.	
FINISH WAVETEK PROCESS	RELEASE, APPROV		MODEL NO 145	REV N
	TOLERANCE UNLESS OTHERWISE SPECIFIED XXX - 010 ANGLES - 1 XX - 030		DWG NO 0101-00-0565	
	DO NOT SCALE DWG		SCALE	CODE IDENT 23338
			SHEET 2 OF 2	

8

7

6

5

4

3

2

1

THIS DOCUMENT CONTAINS PROPRIETARY INFORMATION AND DESIGN RIGHTS BELONGING TO WAVETEK AND MAY NOT BE REPRODUCED FOR ANY REASON EXCEPT CALIBRATION, OPERATION, AND MAINTENANCE WITHOUT WRITTEN AUTHORIZATION.

REV	ECO	BY	DATE	APP
-----	-----	----	------	-----

REFERENCE DESIGNATORS	PART DESCRIPTION	DR10-MFGR-PART-NO	MFGR	WAVETEK NO.	QTY/PT
NONE	ASSY DRWG TRIG/PULSE	0101-00-0565	WVTK	0101-00-0565	1
NONE	SCHEMATIC TRIG/PULSE	0103-00-0565	WVTK	0103-00-0565	1
NONE	KIT, PRE WAVE LOAD 145-0565	145-1557	WVTK	1208-00-1557	1
NONE	BRKT, HEAT SINK	182-308	WVTK	1400-00-5143	3
NONE	SUPER KIT	2500-0145-02	WVTK	2500-0145-02	1
NONE	SUPER KIT	2500-0145-03	WVTK	2500-0145-03	1
NONE	STANDOFF 1.750 H, 250 HEX4-40	P-609-M03-F05-440	UNICP	2800-02-0016	4
1	WASHER	5607-150	SESTM	2800-11-0015	6
5	WASHER, LOCK REQ, S/S #4	MS 3533B-135	CMRCL	2800-45-4000	6
37	LOCK WASHER, INTERNAL TOOTH, SS #4	MS 35333-70	CMRCL	2800-45-4001	4
36	SCREW PLPS PAN M/S 18-8 S/S 4-40X1/4	MS 51957-13	CMRCL	2800-48-4104	4
4	MS, PH, PHLPS, 4-40 X 1/2, SS 18-8 SS, #4-40X1/2	MS 51957-17	CMRCL	2800-48-4108	6
7	NUT, MACHINE SCREW, 18-8 SS, #4-40	NAS 671C4	CMRCL	2800-50-4100	6

WAVETEK PARTS LIST	TITLE PCA, TRIGGER/PULSE	ASSEMBLY NO. 1100-00-0565	REV U
	PAGE 1		

REFERENCE DESIGNATORS	PART DESCRIPTION	DR10-MFGR-PART-NO	MFGR	WAVETEK NO.	QTY/PT
NONE	ASSY DRWG TRIG/PULSE	0101-00-0565	WVTK	0101-00-0565	1
NONE	SCHEMATIC TRIG/PULSE	0103-00-0565	WVTK	0103-00-0565	1
C50 C65	CAP, CER DISK, 5PF, 1KV, 10X	0311-00018	WVTK	1500-00-5011	2
C27	CAP, CER, 10PF, 1KV	DD-100	CRL	1500-01-0011	1
C11 C17 C19 C2 C22 C24 C25 C26 C32 C35 C36 C38 C39 C4 C46 C48 C5 C51 C52 C54 C64 C7 C9	CAP CER MON .01MF 50V, AXIAL	CAC0275U103Z100A	CORNG	1500-01-0310	23
C13 C15	CAP, CER, MON. .1MF, 50V, AXIAL	CAC0325U104Z050A	CORNG	1500-01-0405	2
C30 C49 C66	CAP, CER, 22PF, 1KV	DD-220	CRL	1500-02-2011	3
C67	CAP, CER, 33PF, 1KV	DD-330	CRL	1500-03-3011	1
C31T C33	CAP, MICA, 220PF, 500V, RADIAL	DM15-221J	ARCO	1500-12-2100	2
C40T C55T	CAP, MICA, 50PF, 500V	DM15-500J	ARCO	1500-15-0000	2
C28T	CAP, MICA, 560PF, 300V	DM15-561J	ARCO	1500-15-6100	1
C21 C23	CAP, ELECT, 100MF, 16V	ECEB1CU101	PANAS	1500-31-0101	2
C1 C3	CAP, ELECT, 1000MF, 35V	39D10800350L6	SPRAG	1500-31-0212	2
C29 C60 C61 C62 C63	CAP, ELECT, 22MF, 25V, RA	SRA25V822RM6X7LL	UNCON	1500-32-2002	5

WAVETEK PARTS LIST	TITLE KIT, PRE WAVE LOAD 145-0565	ASSEMBLY NO. 1208-00-1557	REV U
	PAGE 1		

REFERENCE DESIGNATORS	PART DESCRIPTION	DR10-MFGR-PART-NO	MFGR	WAVETEK NO.	QTY/PT
R27	POT, TRIM, 1K	91AR1K	BECK	4600-01-0209	1
R18	POT, TRIM, 20	91AR20	BECK	4600-02-0000	1
R11 R17	RES, C, 1/2W, 5%, 4.7	RC-1/2-4R7J	STKPL	4700-25-0479	2
R9	RES, C, 1/2W, 5%, 220	RC-1/2-221J	STKPL	4700-25-2200	1
R31	RES, C, 1W, 10%, 10K	RC326F103J	AB	4700-35-1002	1
R33 R41 R54 R67	RES, MF, 1/BW, 1%, 100	RN55D-1000F	TRW	4701-03-1000	4
R13 R15 R20 R21 R48 R61	RES, MF, 1/BW, 1%, 1K	RN55D-1001F	TRW	4701-03-1001	6
R45 R46 R49	RES, MF, 1/BW, 1%, 10K	RN55D-1002F	TRW	4701-03-1002	3
R47 R53 R60 R68	RES, MF, 1/BW, 1%, 10	5043ED10R100F	HEPCO	4701-03-1009	4
R39	RES, MF, 1/BW, 1%, 1.5K	RN55D-1501F	TRW	4701-03-1501	1
R32	RES, MF, 1/BW, 1%, 15K	RN55D-1502F	TRW	4701-03-1502	1
R35	RES, MF, 1/BW, 1%, 1.78K	RN55D-1781F	TRW	4701-03-1781	1
R272	RES, MF, 1/BW, 1%, 200	RN55D-2000F	TRW	4701-03-2000	1
R42 R44 R58 R59	RES, MF, 1/BW, 1%, 2.21K	RN55D-2211F	TRW	4701-03-2211	4
R23	RES, MF, 1/BW, 1%, 2.37K	RN55D-2371F	TRW	4701-03-2371	1
R51 R65	RES, MF, 1/BW, 1%, 2.49K	RN55D-2491F	TRW	4701-03-2491	2
R37	RES, MF, 1/BW, 1%, 24.9K	RN55D-2492F	TRW	4701-03-2492	1

WAVETEK PARTS LIST	TITLE KIT, PRE WAVE LOAD 145-0565	ASSEMBLY NO. 1208-00-1557	REV U
	PAGE 3		

REFERENCE DESIGNATORS	PART DESCRIPTION	DR10-MFGR-PART-NO	MFGR	WAVETEK NO.	QTY/PT
2	INSULATOR(TO-220)	60-11-8302-1674	CHOMR	3100-00-0010	6
R26	RES, MF, 1/BW, 1%, 8.06K	RN55D-8061F	TRW	4701-03-8061	1
Q4	TRANS, NPN, TO-220	TIP-29	MOT	4902-00-0290	1
Q2	TRANS, PNP, TO-220	TIP30	TI	4902-00-0300	1
SW5	SWITCH, TOGGLE	7103 P3Y9AV20	C&K	5106-00-0019	1
SW4	SWITCH, TOGGLE	7108 P3Y9AV20	C&K	5106-00-0020	1
Q9	VOLT REGULATOR, POSITIVE	7824	FAIR	7000-78-2400	1
Q12	VOLT REGULATOR, NEGATIVE	MC7905CP	MOT	7000-79-0500	1
Q10	VOLT REGULATOR, NEGATIVE	7924	FAIR	7000-79-2400	1
Q11	VOLT REGULATOR	MA7805UC	FAIR	8000-78-0500	1
IC8	XLATR, 4 TTL-ECL, ECL	MC10124P	MOT	8001-01-2400	1
IC14 IC7	LINE DRIVERS, DUAL 4 INPUT POSITIVE-NAND 50 OHM	74S140	TI	8007-41-4001	2

WAVETEK PARTS LIST	TITLE PCA, TRIGGER/PULSE	ASSEMBLY NO. 1100-00-0565	REV U
	PAGE 2		

REFERENCE DESIGNATORS	PART DESCRIPTION	DR10-MFGR-PART-NO	MFGR	WAVETEK NO.	QTY/PT
C10	DIAL				
C14 C16	CAP, ELECT, 4000MF, 15V	TC0402U015N1L	MAL	1500-34-0211	1
C6 C8	CAP, ELECT, 50MF, 50V	500D506050DD7	SPRAG	1500-35-0003	2
C41 C56	CAP, ELECT, 500MF, 50V	39D50700506L4	SPRAG	1500-35-0103	2
C42 C57	CAP, MYLAR, .001MF, 100V	225P10291MD3	SPRAG	1500-41-0204	2
C43 C58	CAP, MYLAR, .01MF, 100V	225P10391MD3	SPRAG	1500-41-0314	2
C44 C59	CAP, MYLAR, .1MF, 100V	225P10491MD3	SPRAG	1500-41-0444	2
C45	CAP, TANT, 1MF, 35V	150D105X9035A2	SPRAG	1500-71-0502	2
C18 C20 C34 C47	CAP, TANT, 10MF, 20V	150D106X9020B2	SPRAG	1500-71-0601	1
C12 C37 C53	CAP, TANT, 33MF, 10V	150D336X9010B2	SPRAG	1500-73-3601	4
NONE	CAP, TANT, 5.6MF, 35V	150D565X9035B2	SPRAG	1500-75-6502	3
NONE	TRIGGER/PULSE REF: SPEC 0008-00-0455 REV C	145-0565	WVTK	1700-00-0565	1
NONE	SKT, IC, 16PIN	D1LB16P-108T	BURND	2100-03-0028	1
NONE	SKT, IC, 14 PIN	D1LB14P-108T	BURND	2100-03-0066	2
FB1 FB2 FB3 FB4 FB5 FB6 FB7 FB8 FB9	FERRITE BEAD	56-590-65/38	FERRX	3100-00-0001	9

WAVETEK PARTS LIST	TITLE KIT, PRE WAVE LOAD 145-0565	ASSEMBLY NO. 1208-00-1557	REV U
	PAGE 2		

REFERENCE DESIGNATORS	PART DESCRIPTION	DR10-MFGR-PART-NO	MFGR	WAVETEK NO.	QTY/PT
R19	RES, MF, 1/BW, 1%, 301	RN55D-3010F	TRW	4701-03-3010	1
R57 R70	RES, MF, 1/BW, 1%, 392	RN55D-3920F	TRW	4701-03-3920	2
R24	RES, MF, 1/BW, 1%, 3.92K	RN55D-3921F	TRW	4701-03-3921	1
R38T	RES, MF, 1/BW, 1%, 432	RN55D-4320F	TRW	4701-03-4320	1
R7 RB	RES, MF, 1/BW, 1%, 4.75K	RN55D-4751F	TRW	4701-03-4751	2
R10 R16 R43 R50 R62 R63 R64	RES, MF, 1/BW, 1%, 4.99	RN55D-4990F	TRW	4701-03-4990	7
R12 R14 R25 R34 R40 R52 R71	RES, MF, 1/BW, 1%, 4.99K	RN55D-4991F	TRW	4701-03-4991	7
R56 R69	RES, MF, 1/BW, 1%, 511	RN55D-5110F	TRW	4701-03-5110	2
R28	RES, MF, 1/BW, 1%, 5.76K	RN55D-5761F	TRW	4701-03-5761	1
R36	RES, MF, 1/BW, 1%, 6.98K	RN55D-6981F	TRW	4701-03-6981	1
R55 R66	RES, MF, 1/BW, 1%, 78.7K	RN55D-7872F	TRW	4701-03-7872	2
R1 R2	RES NETWORK 10K 2% 10PIN SIP BUSS	4310R-101-103	BOURN	4770-00-0008	2
R29 30	RES, SET, 2-10K, 1/BW QTY: 2: 4701-03-1002	4789-00-0019	IRC	4789-00-0019	1
B	RES, 0 OHM JUMPER	JPO2T680	ROHM	4799-00-0087	9
CR13	DIODE, REFERENCE, LOW LEVEL, TEMP COMP	1N4581	MICRO	4801-01-4581	1

WAVETEK PARTS LIST	TITLE KIT, PRE WAVE LOAD 145-0565	ASSEMBLY NO. 1208-00-1557	REV U
	PAGE 4		

<p>REMOVE ALL BURRS AND BREAK SHARP EDGES</p> <p>MATERIAL</p> <p>DATE</p> <p>CHECKED</p> <p>PROJ ENGR.</p> <p>RELEASE APPROV.</p> <p>UNLESS OTHERWISE SPECIFIED DIMENSIONS ARE IN INCHES TOLERANCES ARE: FRACTIONS DECIMALS ANGLES</p> <p>DO NOT SCALE DRAWING</p>	<p>DRAWN</p> <p>DATE</p> <p>CHECKED</p> <p>PROJ ENGR.</p> <p>RELEASE APPROV.</p>	<p>WAVETEK SAN DIEGO • CALIFORNIA</p> <p>TITLE</p> <p>PARTS LIST</p> <p>PCA, TRIGGER/PULSE</p> <p>SIZE D FSCM NO. 23338 DWG. NO. 1100-00-0565 REV U</p> <p>SCALE MODEL 145 SHEET 1 OF 2</p>
--	--	---

NOTE: UNLESS OTHERWISE SPECIFIED

THIS DOCUMENT CONTAINS PROPRIETARY INFORMATION AND DESIGN RIGHTS BELONGING TO WAVETEK AND MAY NOT BE REPRODUCED FOR ANY REASON EXCEPT CALIBRATION, OPERATION, AND MAINTENANCE WITHOUT WRITTEN AUTHORIZATION.

REV ECO BY DATE APP

REFERENCE DESIGNATORS	PART DESCRIPTION	DR10-MFGR-PART-NO	MFGR	WAVETEK NO.	QTY/PT
CR1 CR10 CR11 CR12 CR2 CR3 CR4 CR5 CR6 CR7 CR8 CR9	DIODE, 1N4002 GEN PURPOSE RECT. 100V, 1A	1N4002	FAIR	4801-02-0001	12
CR14 CR15 CR16 CR17 CR18 CR19 CR20 CR21 CR22 CR23 CR24 CR25 CR26 CR27 CR28 CR29 CR30 CR31 CR32 CR33 CR34 CR35 CR36	DIODE 1N4148 COMPUTER, Q/P, 75V, 200M A, SWITCHING	1N4148	FAIR	4807-02-6666	23
Q1 Q13 Q14 Q15 Q5 Q6	TRANS, GENERAL PURPOSE, NPN, TO-92	2N3903	NSC	4901-03-9030	6
Q17 Q18 Q20 Q21 Q3 Q7 Q8	TRANS, GENERAL PURPOSE, PNP, TO-92	2N3905	ITT	4901-03-9050	7
Q16 Q19	TRANS, NPN, TO-92	MPS2369	MOT	4902-02-3690	2
IC1	OP AMP, DUAL, HIGH GAIN, INTERNALLY COMP	MC1458P1	MOT	7000-14-5800	1
IC3	GATE, NAND, QUAD 2-INPUT	7400	TI	8000-74-0000	1
IC6	GATE, NAND, QUAD 2-INP, TTL	SN74LS00N	TI	8000-74-0010	1
IC5	BUF/DRIVERS, HEX, W/DC HIGH VOLTAGE OUTPUTS	7407	TI	8000-74-0700	1
IC4	GATE AND, QUAD 2-INP, TTL	74LS08	TI	8000-74-0810	1
WAVETEK PARTS LIST		TITLE KIT, PRE WAVE LOAD 145-0565	ASSEMBLY NO. 1208-00-1557		REV U
PAGE 5					

REFERENCE DESIGNATORS	PART DESCRIPTION	DR10-MFGR-PART-NO	MFGR	WAVETEK NO.	QTY/PT
NONE	KIT, HARNESS & WIRE -145	145-1562	WVTK	1207-00-1562	1
NONE	ASSY, LAMP 143-145	143-145-1960	WVTK	1207-00-1960	1
NONE	ASSY, COAX 143-145-0585	143-145-1962	WVTK	1207-00-1962	1
NONE	ASSY, COAX 143-145-0585	143-145-1963	WVTK	1207-00-1963	1
NONE	ASSY, COAX 145-0565	145-1978	WVTK	1207-00-1978	1
NONE	ASSY, COAX 145-0565	145-1979	WVTK	1207-00-1979	1
NONE	ASSY, COAX 145-0565	145-1980	WVTK	1207-00-1980	1
NONE	ASSY, COAX 145-0565	145-1981	WVTK	1207-00-1981	1
NONE	ASSY, COAX 145-0565	145-1982	WVTK	1207-00-1982	1
NONE	ASSY, MOLEX CONNECTOR HARNESS 145-0565	145-1983	WVTK	1207-00-1983	1
WAVETEK PARTS LIST		TITLE SUPER KIT	ASSEMBLY NO. 2500-0145-02		REV
PAGE 1					

REFERENCE DESIGNATORS	PART DESCRIPTION	DR10-MFGR-PART-NO	MFGR	WAVETEK NO.	QTY/PT
IC10 IC12	FLIP-FLOP DUAL D- POS EDGE TRIG	74S74	TI	8000-74-7401	2
IC2	FLIP-FLOP DUAL, D-POS EDGE TRIG, TTL	74LS74	TI	8000-74-7410	1
IC9	GATE, XDR QUAD 2INP TIONLY	SN74LSB6N	TI	8000-74-8611	1
IC11 IC13	GATE, NAND, S/TRIG, QUAD 2-INP POS	74S132	TI	8007-41-3201	2
WAVETEK PARTS LIST		TITLE KIT, PRE WAVE LOAD 145-0565	ASSEMBLY NO. 1208-00-1557		REV U
PAGE 6					

REFERENCE DESIGNATORS	PART DESCRIPTION	DR10-MFGR-PART-NO	MFGR	WAVETEK NO.	QTY/PT
NONE	ASSY, SWITCH SW-1 145-0565	145-1559	WVTK	1202-00-1559	1
NONE	ASSY, SWITCH SW-2 145-0565	145-1560	WVTK	1202-00-1560	1
NONE	ASSY, SWITCH SW-3 145-0565	145-1561	WVTK	1202-00-1561	1
WAVETEK PARTS LIST		TITLE SUPER KIT	ASSEMBLY NO. 2500-0145-03		REV
PAGE 1					

NOTE: UNLESS OTHERWISE SPECIFIED

REMOVE ALL BURRS AND BREAK SHARP EDGES	DRAWN	DATE	WAVETEK SAN DIEGO • CALIFORNIA			
MATERIAL	CHECKED					
	PROJ. ENGR.					
	RELEASE APPROV.					
FINISH WAVETEK PROCESS	UNLESS OTHERWISE SPECIFIED DIMENSIONS ARE IN INCHES TOLERANCES ARE: FRACTIONS DECIMALS ANGLES ".XX" ".XXX"		SIZE D	FSCM NO. 23338	DWG. NO. 1100-00-0565	REV U
DO NOT SCALE DRAWING	SCALE	MODEL	145	SHEET	2 OF 2	

THIS DOCUMENT CONTAINS PROPRIETARY INFORMATION AND DESIGN RIGHTS BELONGING TO WAVETEK AND MAY NOT BE REPRODUCED FOR ANY REASON EXCEPT CALIBRATION, OPERATION, AND MAINTENANCE WITHOUT WRITTEN AUTHORIZATION.

REV	ECN	BY	DATE	APP
A	4073	JTC	12/10/83	JTC
E	4610	JTC	11-19-83	ALT.

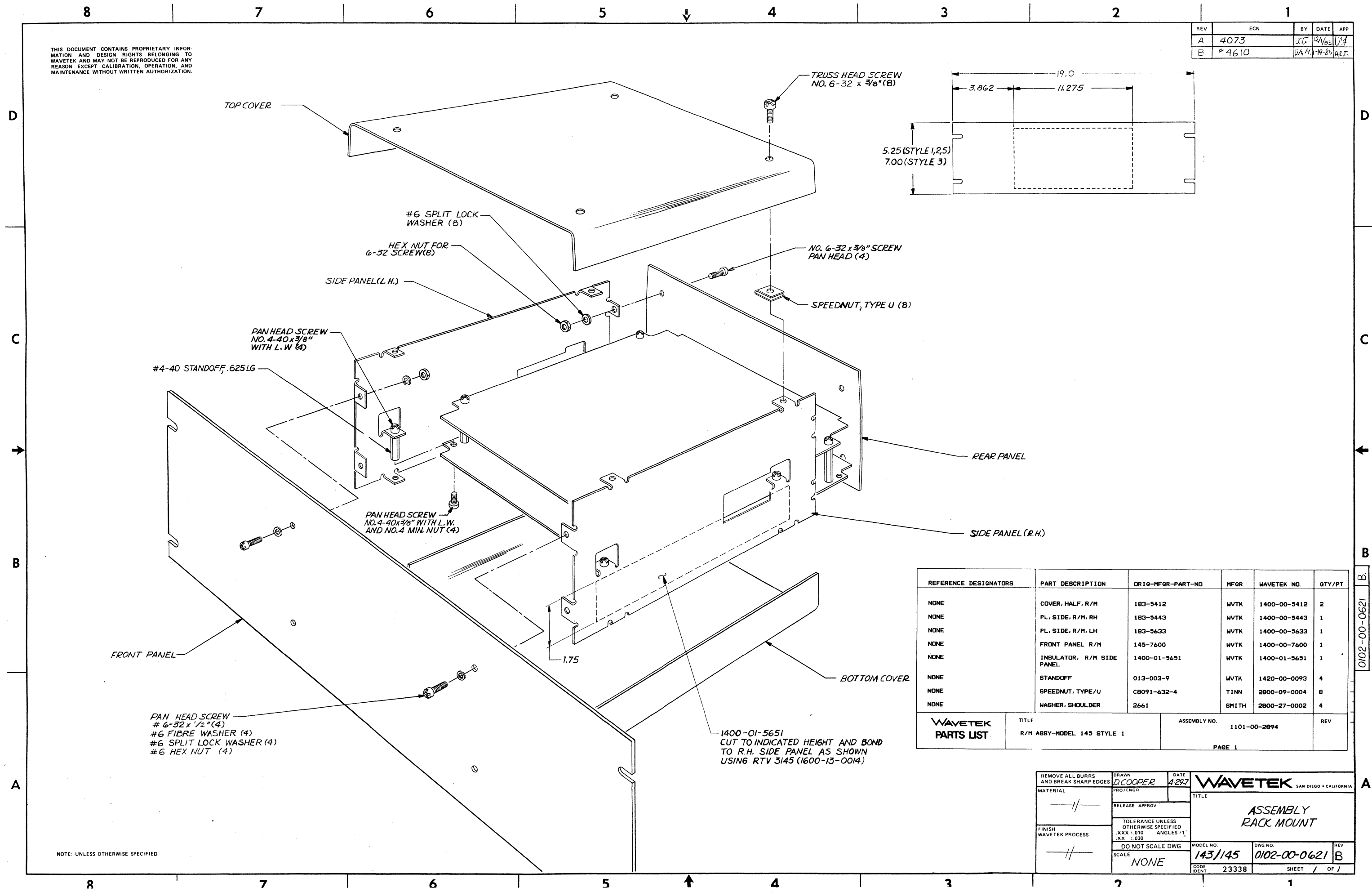

REFERENCE DESIGNATORS	PART DESCRIPTION	ORIG-MFOR-PART-NO	MFOR	WAVETEK NO.	QTY/PT
NONE	COVER, HALF, R/M	183-5412	WVTK	1400-00-5412	2
NONE	PL, SIDE, R/M, RH	183-3443	WVTK	1400-00-5443	1
NONE	PL, SIDE, R/M, LH	183-5633	WVTK	1400-00-5633	1
NONE	FRONT PANEL R/M	145-7600	WVTK	1400-00-7600	1
NONE	INSULATOR, R/M SIDE PANEL	1400-01-5651	WVTK	1400-01-5651	1
NONE	STANDOFF	013-003-9	WVTK	1420-00-0093	4
NONE	SPEEDNUT, TYPE/U	C8091-632-4	TINN	2800-09-0004	8
NONE	WASHER, SHOULDER	2661	SMITH	2800-27-0002	4

WAVETEK PARTS LIST	TITLE R/M ABBY-MODEL 145 STYLE 1	ASSEMBLY NO. 1101-00-2894	REV
PAGE 1			

REMOVE ALL BURRS AND BREAK SHARP EDGES	DRAWN D COOPER	DATE 4-29-7	WAVETEK SAN DIEGO • CALIFORNIA
MATERIAL	PROJ ENGR	RELEASE APPROV	TITLE ASSEMBLY RACK MOUNT
FINISH WAVETEK PROCESS	TOLERANCE UNLESS OTHERWISE SPECIFIED .XXX : .010 ANGLES : 1° XX : .030		MODEL NO. 143/145
SCALE NONE	DO NOT SCALE DWG	DWG NO. 0102-00-0621	REV B
	SCALE	CODE IDENT 23338	SHEET / OF /

NOTE: UNLESS OTHERWISE SPECIFIED

0102-00-0621

REV	ECN	BY	DATE	APP
A	ECO # 89-262	MS	4/21/89	AMB

THIS DOCUMENT CONTAINS PROPRIETARY INFORMATION AND DESIGN RIGHTS BELONGING TO WAVETEK AND MAY NOT BE REPRODUCED FOR ANY REASON EXCEPT CALIBRATION, OPERATION, AND MAINTENANCE WITHOUT WRITTEN AUTHORIZATION.

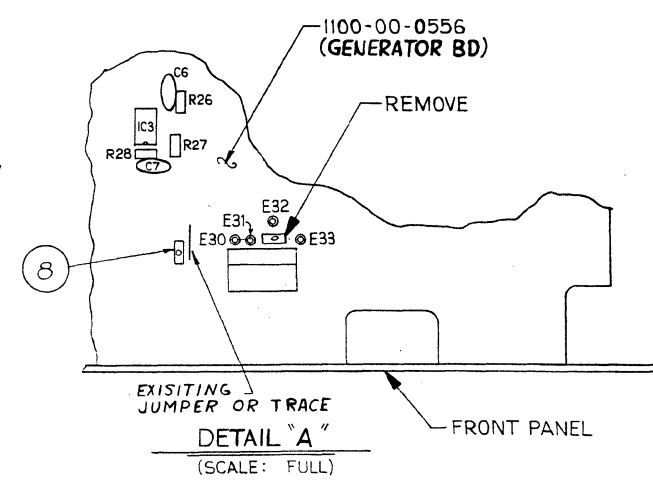
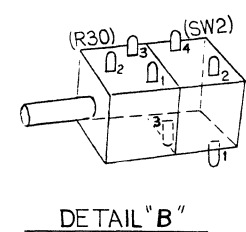
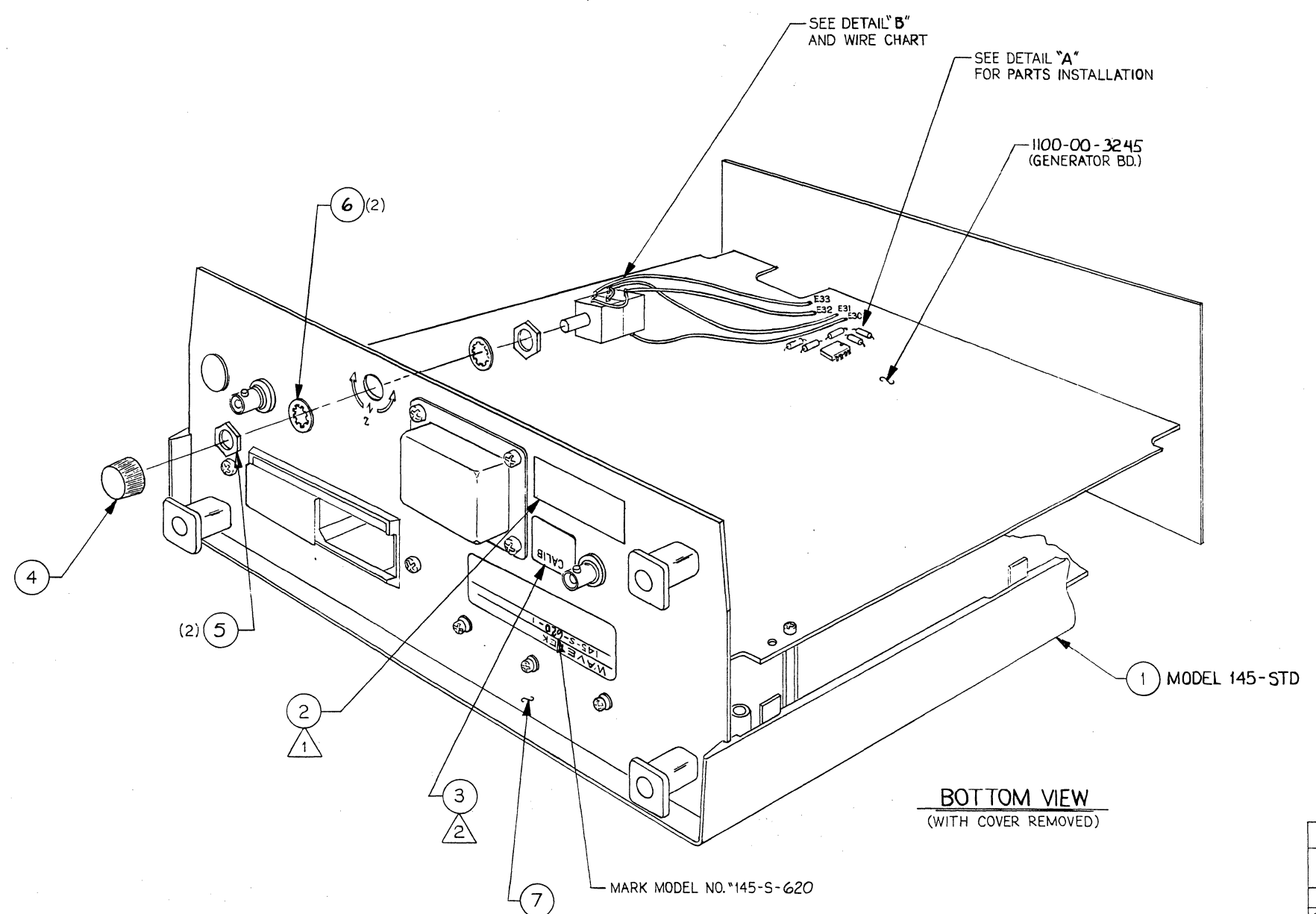

BOTTOM VIEW
(WITH COVER REMOVED)

WIRE CHART			
FROM	TO	WIRE COLOR	LENGTH
R30-1	SW2-4	BARE	0.5
SW2-4	E31	RED	9.0
R30-2	SW2-2	ORN	1.0
SW2-2	E32	ORN	9.0
R30-3	SW2-3	YEL	1.5
SW2-3	E33	YEL	9.0
SW2-1	E30	BRN	9.0

▲ UPON COMPLETION OF CALIBRATION AND QUALITY CONTROL ACCEPTANCE APPLY SIGNED CALIBRATION LABEL IN AREA INDICATED.

▲ MARK LABEL FOR OPTION 002

NOTE: UNLESS OTHERWISE SPECIFIED

REMOVE ALL BURRS AND BREAK SHARP EDGES	DRAWN: MELISSA SMITH	DATE: 4/21/89	
MATERIAL: /	PROJECTOR: /	RELEASE APPROV: /	
FINISH WAVETEK PROCESS: /	TOLERANCE UNLESS OTHERWISE SPECIFIED XXX - .010 ANGLES - 1° XX - .030		MODEL 145-002 OPTION SYMMETRY CONTROL
DO NOT SCALE DWG	SCALE: NONE	MODEL NO. 145-S-620	DWG NO. 1101-00-3243
		REV: A	CODE: 23338
			SHEET 1 OF 3

THIS DOCUMENT CONTAINS PROPRIETARY INFORMATION AND DESIGN RIGHTS BELONGING TO WAVETEK AND MAY NOT BE REPRODUCED FOR ANY REASON EXCEPT CALIBRATION, OPERATION, AND MAINTENANCE WITHOUT WRITTEN AUTHORIZATION.

NOTES:
ALL CONNECTIONS TO BE MECHANICALLY SECURE PRIOR TO SOLDERING GROUND WIRES.

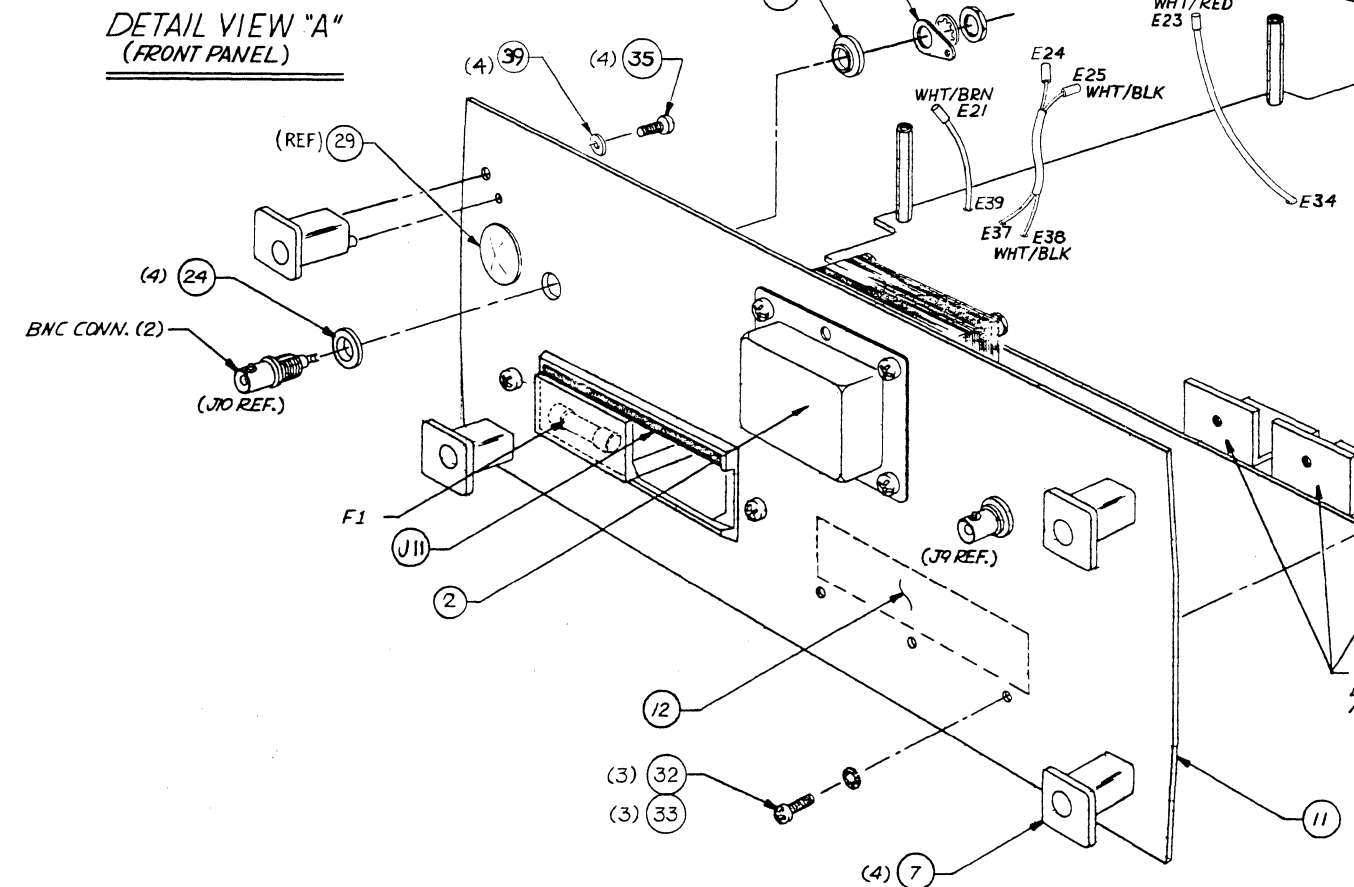
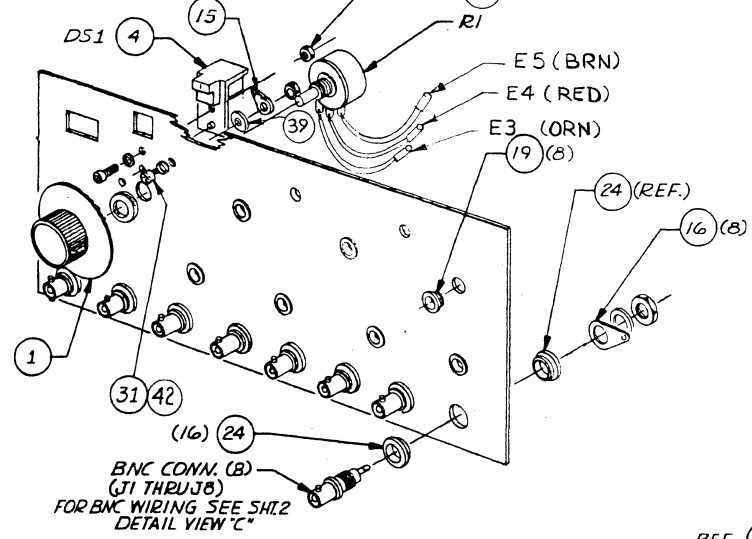
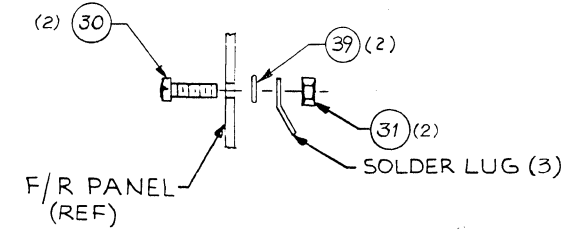

SEE DETAIL VIEW "A"
(FOR FRONT PANEL)

DETAIL VIEW "B"
REAR PANEL
FOR WIRING SEE
DETAIL "D"

SEE DETAIL "D"
& "E"

7. AFTER INSTALLATION OF FRONT AND REAR FEET APPLY (1) DROP OF LOCTITE 414 (OR EQUIV.) TO SCREW THREADS (6). ALLOW 1 HR. MIN. TO DRY WITH FEET UP

SEE DETAIL VIEW "B"
(FOR REAR PANEL)

- △ APPLY INSULATOR TO BOTTOM SIDE AS ARROW INDICATES
- △ INSTALL ITEM 28 USING DOW CORNING RTV 3140 TO COVER. THEN APPLY INSULATOR. SEE △
- △ CEMENT ITEM G(2) TO ITEM 5 (TYP. BOTH SIDES)
- △ MOUNT SWITCH TO RC. BOARD PRIOR TO INSTALLING FRONT PANEL. USE NO. 2-56 x 1/4 PAN HEAD SCREW WITH NUT (2)

T1 FOR WIRING SEE
DETAIL "D"
SHT 2 OF 2

SEE SEPARATE PARTS LIST 1100-00-3243

REMOVE ALL BURRS AND BREAK SHARP EDGES		DRAWN MELISSA SMITH	DATE 7/10/88	WAVETEK SAN DIEGO - CALIFORNIA	
MATERIAL		PROJ ENGR	TITLE ASSEMBLY STANDARD CHASSIS		
FINISH WAVETEK PROCESS		RELEASE, APPROV	TOLERANCE UNLESS OTHERWISE SPECIFIED XXX - 010 ANGLES - 1° XX - 030		
SCALE		DO NOT SCALE DWG	MODEL NO 145-S-620	DWG NO 1101-00-3243	REV A
			CODE IDENT 23338	SHEET 2 OF 3	

THIS DOCUMENT CONTAINS PROPRIETARY INFORMATION AND DESIGN RIGHTS BELONGING TO WAVETEK AND MAY NOT BE REPRODUCED FOR ANY REASON EXCEPT CALIBRATION, OPERATION, AND MAINTENANCE WITHOUT WRITTEN AUTHORIZATION.

REV ECN BY DATE APP

GROUND LUG FRONT PANEL (GRN/YEL)
ADD 1 FISH PAPER INSULATOR (P/N 1400-00-8370) BEFORE SHRINK TUBING

DETAIL VIEW "D"
REAR PANEL WIRING

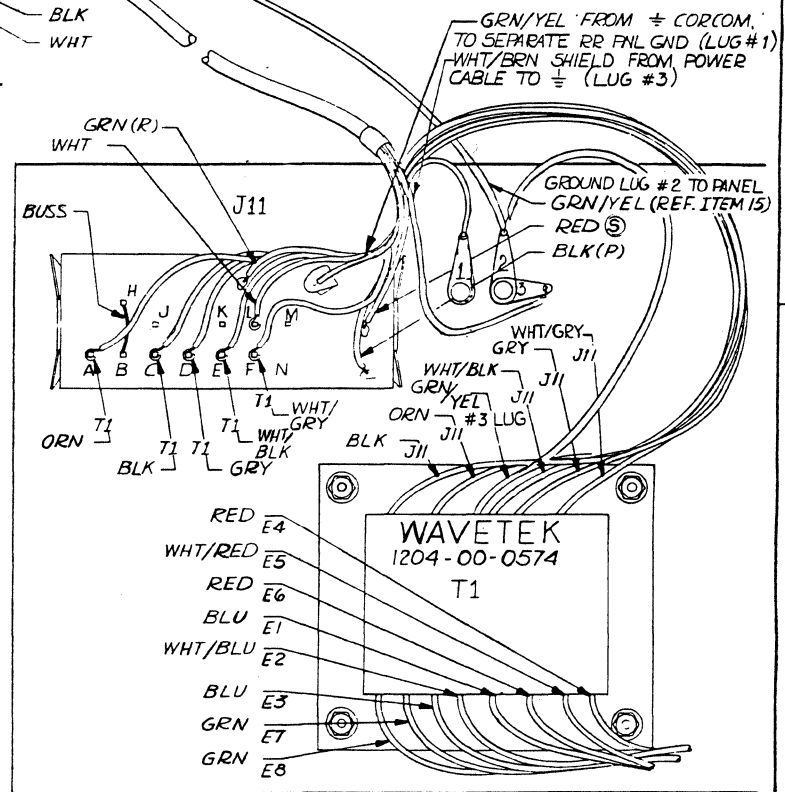

DETAIL VIEW "C"
BNC CONN. WIRING, FRONT PANEL

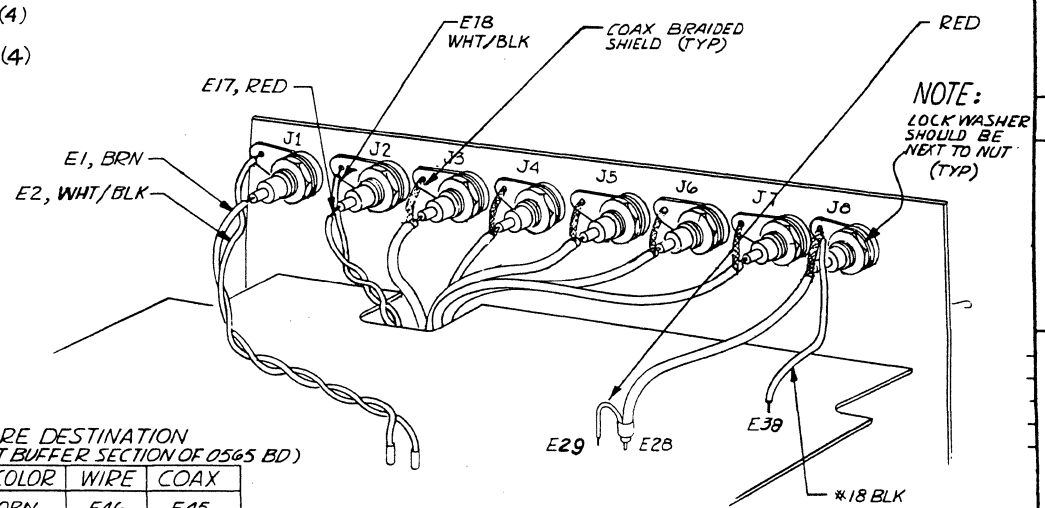

WIRE DESTINATION
(OUTPUT BUFFER SECTION OF 0565 BD)

FROM	WIRE COLOR	WIRE	COAX
J3	WHT/ORN	E46	E45
J4	WHT/YEL	E47	E44
J5	WHT/GRN	E43	E42
J6	WHT/BLU	E41	E40
J7	WHT/VIO	E31	E30

REMOVE ALL BURRS AND BREAK SHARP EDGES	DRAWN MELISSA SMITH	DATE 1/20/89	WAVETEK SAN DIEGO • CALIFORNIA
MATERIAL	PROJECT #	RELEASE APPROV	
FINISH WAVETEK PROCESS	TOLERANCE UNLESS OTHERWISE SPECIFIED XXX - 010 ANGLES - 1 XX - 030		TITLE ASSEMBLY STANDARD CHASSIS
DO NOT SCALE DWG		MODEL NO 145-5-620	DWG NO 1101-00-3243
SCALE		CODE 23338	REV A
		SHEET 3 OF 3	

NOTE: UNLESS OTHERWISE SPECIFIED

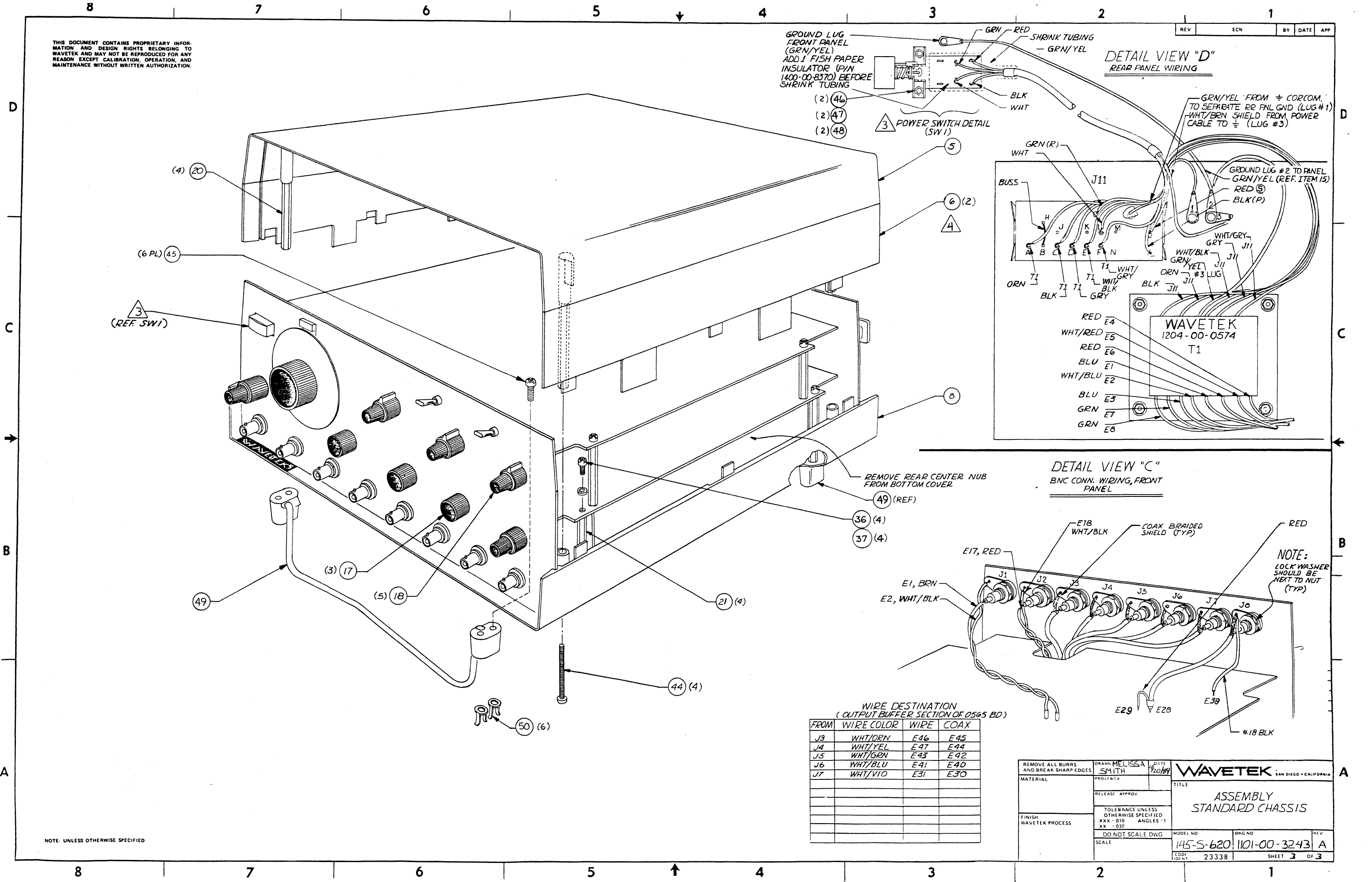

THIS DOCUMENT CONTAINS PROPRIETARY INFORMATION AND DESIGN RIGHTS BELONGING TO WAVETEK AND MAY NOT BE REPRODUCED FOR ANY REASON EXCEPT CALIBRATION, OPERATION, AND MAINTENANCE WITHOUT WRITTEN AUTHORIZATION.

REV	ECO	BY	DATE	APP
-----	-----	----	------	-----

REFERENCE DESIGNATORS	PART DESCRIPTION	DRG-MFGR-PART-NO	MFGR	WAVETEK NO.	QTY/PT
NONE	ASSY DRWG. 145-002 OPTION, SYMMETRY CONTROL	0102-00-0487	WVTK	0102-00-0487	1
NONE	PCA, TRIGGER/PULSE	145-565	WVTK	1100-00-0565	1
NONE	A/D CHASSIS 145-S-620	1101-00-3243	WVTK	1101-00-3243	1
NONE	REAR PANEL ASSY 145-S-620	1200-00-3244	WVTK	1200-00-3244	1
NONE	ASSY, FRONT PANEL -145	145-1555	WVTK	1206-00-1555	1
27	SHIELD, PWR	801-6210	WVTK	1400-00-6210	1
NONE	INSULATOR PLATE REF: 3200-03-0004	145-3931	WVTK	1400-01-3931	1
18	CDAX KNOB SET	RB-67-1-SB+0-M-9	ROGAN	2400-01-0009	3
NONE	CLAMP, CABLE	E-4	RICH	2800-00-0022	1
48	WASHER, LOCK, SPLIT S/S #2	MS35338-134	MS	2800-45-2000	2
33	WASHER, LOCK REG, S/S #4	MS 35338-135	CMRCL	2800-45-4000	3
39	WASHER, LOCK, REG S/S #6	MS 35338-136	CMRCL	2800-45-6000	9
40	WASHER, FLAT, SS, #6	AN 960C6	CMRCL	2800-46-6001	1

WAVETEK PARTS LIST
 TITLE CHASSIS ASSY 145-S-620
 ASSEMBLY NO. 1100-00-3243
 REV B
 PAGE 1

REFERENCE DESIGNATORS	PART DESCRIPTION	DRG-MFGR-PART-NO	MFGR	WAVETEK NO.	QTY/PT
NONE	ASSY DRWG. CHASSIS	0102-00-0575	WVTK	0102-00-0575	1
T1	TRANSFORMER	143-574	WVTK	1204-00-0574	1
NONE	ASSY, CONDUCTOR CABLE 143-145	143-145-1959	WVTK	1207-00-1959	1
2	END BELL	1400-00-0174	WVTK	1400-00-0174	1
7	POST	180-302	WVTK	1400-00-5020	4
NONE	INSULATOR, PWR SWITCH REF: 1600-99-0001	801-8370	WVTK	1400-00-8370	1
2	LABEL, OPTION, MODEL 23	1400-01-9890	WVTK	1400-01-9890	1
11	REAR PANEL	1400-02-0600		1400-02-0600	1
C1	CAP CER MON .01MF 50V, AXIAL	CAC0225U103Z100A	CORNG	1300-01-0310	1
J10 J9	CONN BNC	KC-7946	KING	2100-01-0002	2
J11	CONN, RECEPTACLE	6VJ1	CORCM	2100-03-0026	1
16A	SOLDER LUG	1497	SMITH	2100-04-0012	2
15A	SOLDER LUG	11A144	ZIER	2100-04-0025	3
4	KNOB STD	RB-67-1-SB-M	ROGAN	2400-01-0008	1
F1	FUSE, 1/2A, 250V	313.500	LITFU	2400-05-0010	1

WAVETEK PARTS LIST
 TITLE REAR PANEL ASSY 145-S-620
 ASSEMBLY NO. 1200-00-3244
 REV B
 PAGE 1

REFERENCE DESIGNATORS	PART DESCRIPTION	DRG-MFGR-PART-NO	MFGR	WAVETEK NO.	QTY/PT
NONE	ASSY DRWG. CHASSIS	0102-00-0575	WVTK	0102-00-0575	1
NONE	DIAL ASSY-145	1201-00-1885	WVTK	1201-00-1885	1
4	INDICATOR, DIAL	180-303	WVTK	1400-00-4970	1
9	PANEL, FRONT	145-6770	WVTK	1400-00-6770	1
J1 J2 J3 J4 J5 J6 J7 J8	CONN BNC	KC-7946	KING	2100-01-0002	8
16	SOLDER LUG	1497	SMITH	2100-04-0012	8
15	SOLDER LUG	11A144	ZIER	2100-04-0025	1
19	BUSHING NYLINER	4L2FF	THOMN	2800-01-0002	8
24	WASHER, SHOULDER, WHITE	2668	SMITH	2800-27-0004	16
55	WASHER, WAVE SPRING	5804-133-1	SEA	2800-28-0021	1
56	WASHER, FLAT, BRASS, .025 ID, .400 OD	5714-62-32	SESTM	2800-28-0022	1
33	WASHER, LOCK REG, S/S #4	MS 35338-135	CMRCL	2800-45-4000	1
32	SCREW PLPS PAN M/S 18-8 S/S 4-40X3/8	MS 51957-15	CMRCL	2800-48-4106	1
42	SCREW PLPS PAN M/S 18-8 S/S 6-32X3/8	MS 51957-28	CMRCL	2800-48-6106	1
34	NUT, MACHINE SCREW,	NAS 671C4	CMRCL	2800-50-4100	1

WAVETEK PARTS LIST
 TITLE ASSY, FRONT PANEL -145
 ASSEMBLY NO. 1206-00-1555
 REV B
 PAGE 1

REFERENCE DESIGNATORS	PART DESCRIPTION	DRG-MFGR-PART-NO	MFGR	WAVETEK NO.	QTY/PT
46	LARGE OUTLINE SCREW PLPS PAN M/S 18-8 S/S 2-56X1/4	SCREW PH 2-56X1/4S/S	CMRCL	2800-48-2104	2
32	SCREW PLPS PAN M/S 18-8 S/S 4-40X3/8	MS 51957-15	CMRCL	2800-48-4106	3
42	SCREW PLPS PAN M/S 18-8 S/S 6-32X3/8	MS 51957-28	CMRCL	2800-48-6106	1
38	SCREW, MACH, PH, PHLPS, 6-32 X 1/2, SS 18-8 SS, #6-32X1/2	MS 51957-30	CMRCL	2800-48-6108	1
47	NUT, MACHINE SCREW, 18-8 SS, #2-56	2-56 M/S NUT 18-8 S/S	CMRCL	2800-50-2100	2
41	NUT, MACHINE SCREW, 18-8 SS, #6-32	MS 35649-64	CMRCL	2800-50-6101	2

WAVETEK PARTS LIST
 TITLE CHASSIS ASSY 145-S-620
 ASSEMBLY NO. 1100-00-3243
 REV B
 PAGE 2

REFERENCE DESIGNATORS	PART DESCRIPTION	DRG-MFGR-PART-NO	MFGR	WAVETEK NO.	QTY/PT
5	NUT, PANEL, 3/8X1/2X.09 2.Z	3/8 X 1/2 NUT	CMRCL	2800-16-0000	2
24	WASHER, SHOULDER, WHITE	2668	SMITH	2800-27-0004	4
6	WASHER, INTERNAL TOOTH, 3/8 IN.	3/8ITLW	CMRCL	2800-28-0000	2
29	PLUG BUTTON	2663(BLACK)	HEYCO	2800-35-0004	1
39	WASHER, LOCK, REG S/S #6	MS 35338-136	CMRCL	2800-45-6000	4
NONE	WASHER, FLAT, SS, #6 LARGE OUTLINE	AN 960C6	CMRCL	2800-46-6001	4
43	MS, PH, PHLPS, 6-32 X 1 1/2, SS 18-8 SS, #6-32X1.5	MS 51957-36	CMRCL	2800-48-6124	4
30	SCREW, CAP, SOCKET HD, 6-32X3/8	MS 16995-17	CMRCL	2800-49-6106	2
41	NUT, MACHINE SCREW, 18-8 SS, #6-32	MS 35649-64	CMRCL	2800-50-6101	4
31	NUT, LOCKING, MS, 6-32, SS 18-8 SS, #6-32	MS 20364-632	CMRCL	2800-50-6102	2
35	SCREW, BELF-TAP, PH, PHL PS, #6 X 3/8, SS TYPE BF, #6X3/8	MS24626-19	CMRCL	2800-59-6006	4
R30	CONTROL SHAFT, SWITCH-POT, CERMET, LINEAR 50K 10%, CCH DETENT	72LIN048S503W	AB	4602-05-0304	1
SW1	SWITCH ASSY PB	1XTA0003TA100B-W/NE152	ECG	5102-00-0008	1
NONE	PWR CORD	17251	BELDN	6001-80-0005	1

WAVETEK PARTS LIST
 TITLE REAR PANEL ASSY 145-S-620
 ASSEMBLY NO. 1200-00-3244
 REV B
 PAGE 2

REFERENCE DESIGNATORS	PART DESCRIPTION	DRG-MFGR-PART-NO	MFGR	WAVETEK NO.	QTY/PT
31	18-8 SS, #4-40				
	NUT, LOCKING, MS, 6-32, SS 18-8 SS, #6-32	MS 20364-632	CMRCL	2800-50-6102	1
R1	POT, DIAL, 5K+/-5%, PRECISION, LINEAR	ECONOPOT MKIII 78PF-14	NEI	4600-05-0212	1

WAVETEK PARTS LIST
 TITLE ASSY, FRONT PANEL -145
 ASSEMBLY NO. 1206-00-1555
 REV B
 PAGE 2

NOTE: UNLESS OTHERWISE SPECIFIED

REMOVE ALL BURRS AND BREAK SHARP EDGES	DRAWN	DATE	WAVETEK SAN DIEGO & CALIFORNIA
MATERIAL	CHECKED		
	PROJ. ENGR.		
	RELEASE APPROV.		
FINISH WAVETEK PROCESS	UNLESS OTHERWISE SPECIFIED DIMENSIONS ARE IN INCHES TOLERANCES ARE: FRACTIONS DECIMALS ANGLES ± .XX ± .XXX ± °		REV
DO NOT SCALE DRAWING	SIZE D	FSCM NO. 23338	DWG. NO. 1100-00-3243
	SCALE	145-S-620	SHEET 1 OF 1

THIS DOCUMENT CONTAINS PROPRIETARY INFORMATION AND DESIGN RIGHTS BELONGING TO WAVETEK AND MAY NOT BE REPRODUCED FOR ANY REASON EXCEPT CALIBRATION, OPERATION, AND MAINTENANCE WITHOUT WRITTEN AUTHORIZATION.

REV	ECN	BY	DATE	APP
A	ECO # 89-262	ME	4/21/89	JMS

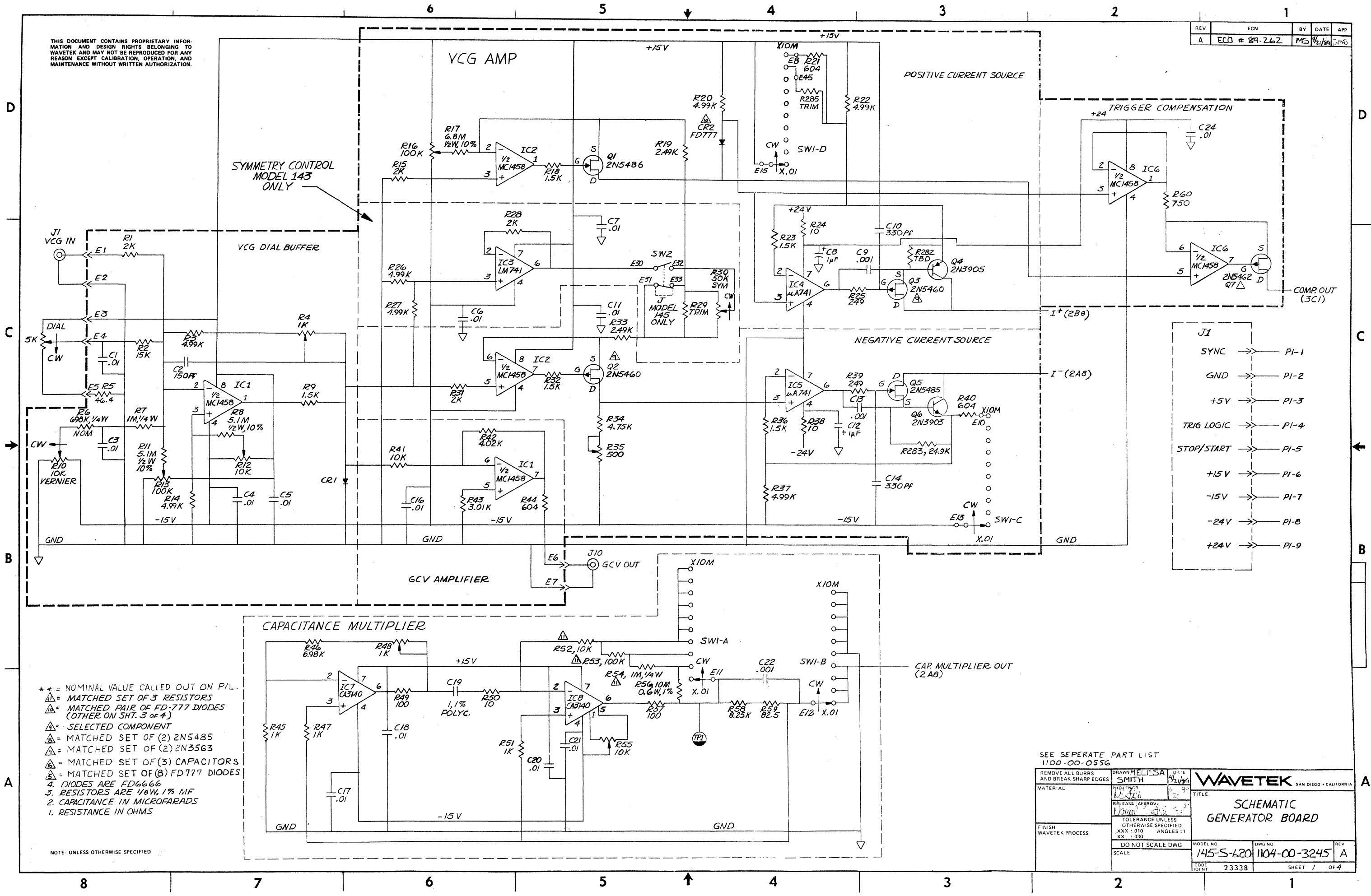

J1

SYNC	PI-1
GND	PI-2
+15V	PI-3
TRIG LOGIC	PI-4
STOP/START	PI-5
+15V	PI-6
-15V	PI-7
-24V	PI-8
+24V	PI-9

- ** = NOMINAL VALUE CALLED OUT ON P/L.
- △ = MATCHED SET OF 3 RESISTORS
- ▴ = MATCHED PAIR OF FD-777 DIODES (OTHER ON SHT. 3 OF 4)
- ▲ = SELECTED COMPONENT
- ▾ = MATCHED SET OF (2) 2N5485
- ▿ = MATCHED SET OF (2) 2N3563
- ⊖ = MATCHED SET OF (3) CAPACITORS
- ⊕ = MATCHED SET OF (8) FD777 DIODES
- 4. DIODES ARE FD6666
- 3. RESISTORS ARE 1/8W, 1% MF
- 2. CAPACITANCE IN MICROFARADS
- 1. RESISTANCE IN OHMS

NOTE: UNLESS OTHERWISE SPECIFIED

SEE SEPERATE PART LIST
1100-00-0556

REMOVE ALL BURRS AND BREAK SHARP EDGES	DRAWN MELISSA SMITH	DATE 4/21/89	
MATERIAL	PROFESSOR	REV 3	
FINISH WAVETEK PROCESS	RELEASE APPROV. [Signature]	DATE 4/21/89	TITLE
SCALE	TOLERANCE UNLESS OTHERWISE SPECIFIED .XXX ± 010 XX ± 030	DO NOT SCALE DWG	SCHMATIC GENERATOR BOARD
	MODEL NO. 145-S-620	DWG NO. 1104-00-3245	REV A
	CODE 23338	SHEET 1 OF 4	

THIS DOCUMENT CONTAINS PROPRIETARY INFORMATION AND DESIGN RIGHTS BELONGING TO WAVETEK AND MAY NOT BE REPRODUCED FOR ANY REASON EXCEPT CALIBRATION, OPERATION, AND MAINTENANCE WITHOUT WRITTEN AUTHORIZATION.

REV	ECN	BY	DATE	APP

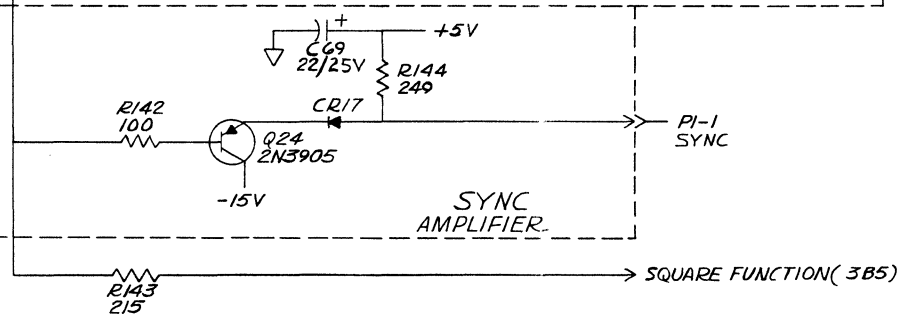
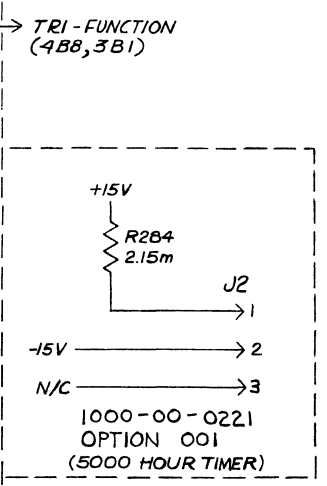
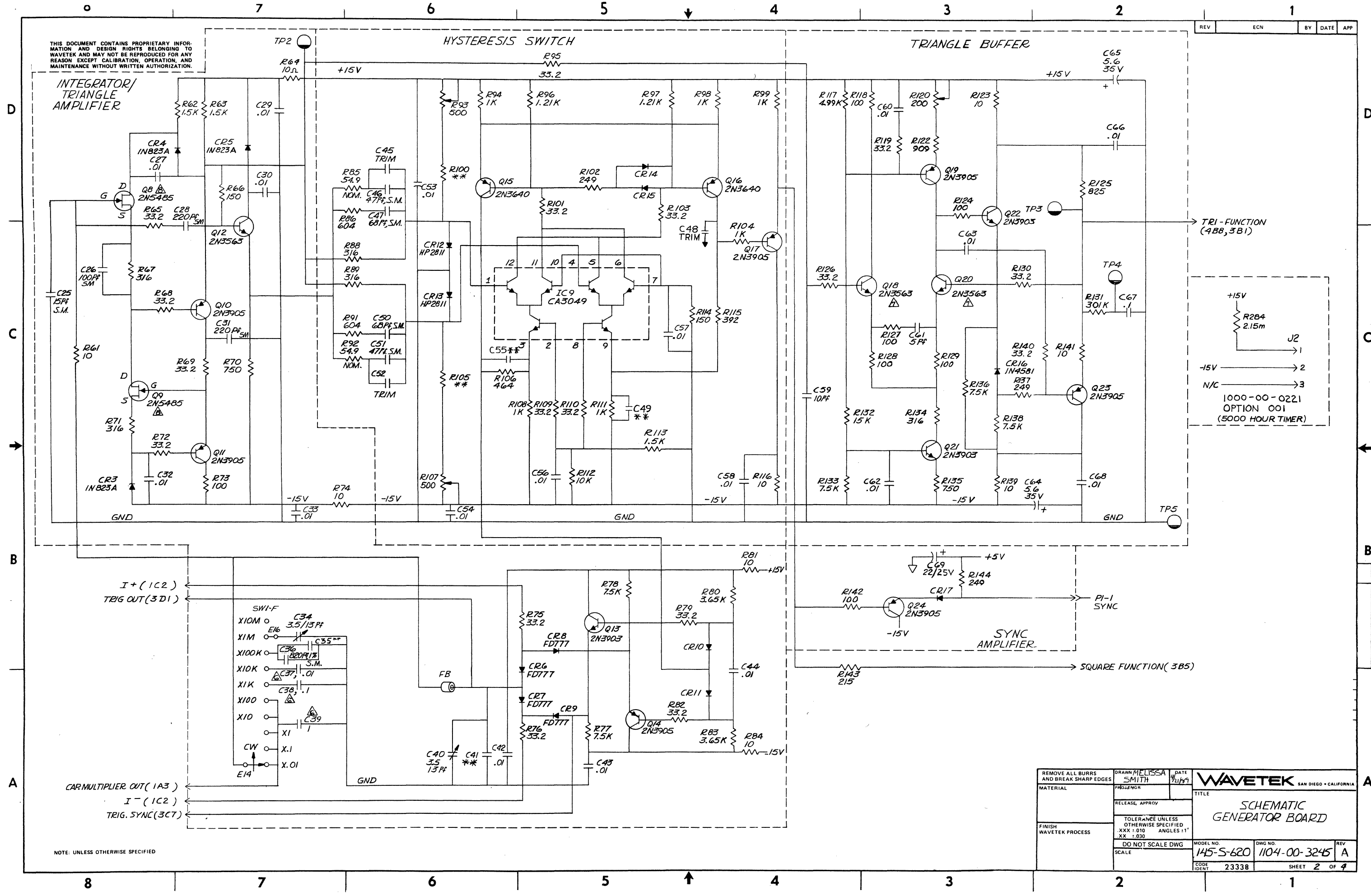

CAR MULTIPLIER OUT (1A3)
I+ (IC2)
TRIG. SYNC (3C7)
I- (IC2)

NOTE: UNLESS OTHERWISE SPECIFIED

REMOVE ALL BURRS AND BREAK SHARP EDGES	DRAWN: MELISSA SMITH	DATE: 4/21/79	WAVETEK SAN DIEGO • CALIFORNIA TITLE: SCHEMATIC GENERATOR BOARD
MATERIAL	PROJ: 4298	RELEASE, APPROV	
FINISH: WAVETEK PROCESS	TOLERANCE UNLESS OTHERWISE SPECIFIED: .XXX ± 010 ANGLES: 1° XX ± 030		MODEL NO.: 145-5-620 DWG NO.: 1104-00-3245 REV: A
SCALE	DO NOT SCALE DWG	CODE IDENT: 23338	

THIS DOCUMENT CONTAINS PROPRIETARY INFORMATION AND DESIGN RIGHTS BELONGING TO WAVETEK AND MAY NOT BE REPRODUCED FOR ANY REASON EXCEPT CALIBRATION, OPERATION, AND MAINTENANCE WITHOUT WRITTEN AUTHORIZATION.

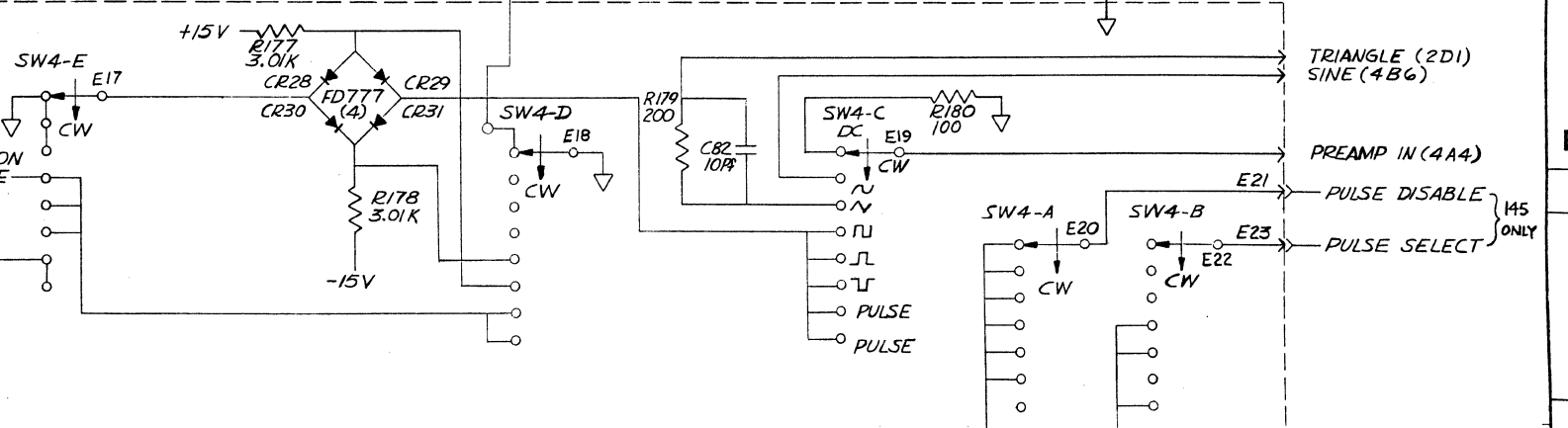
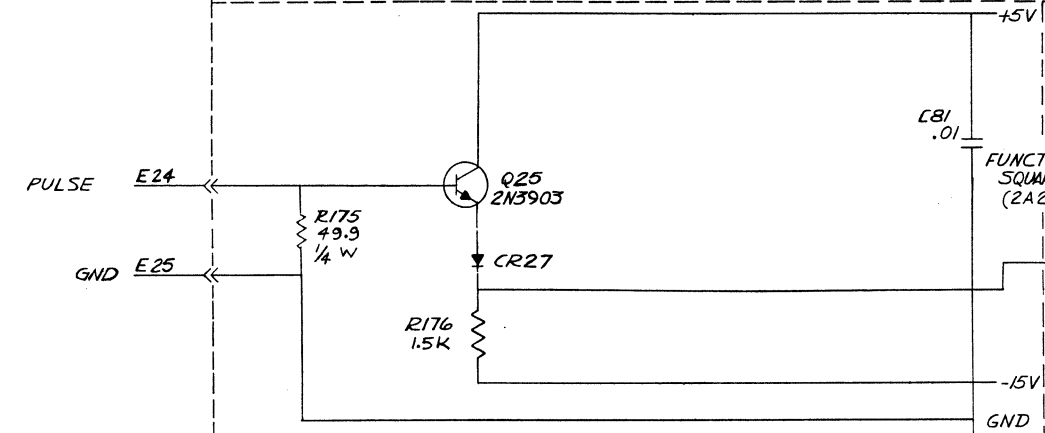
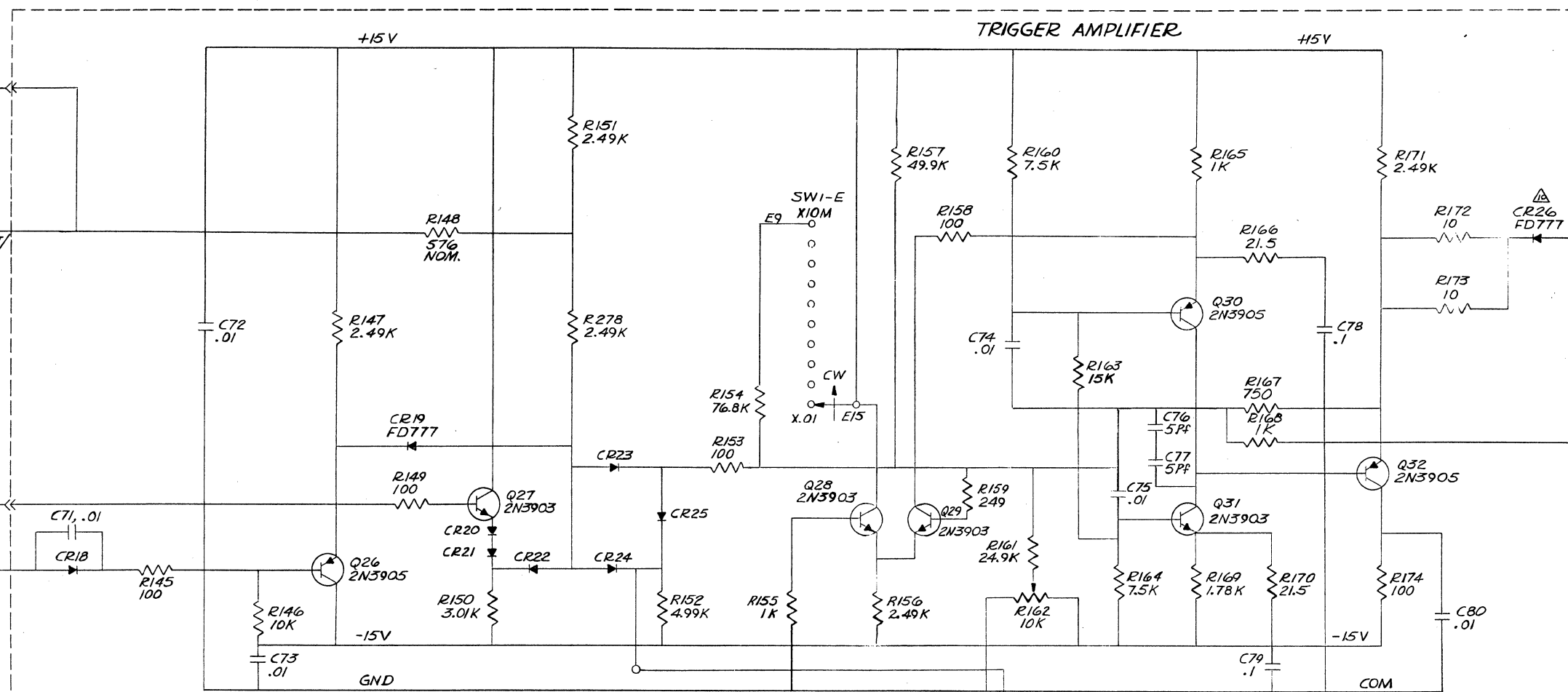
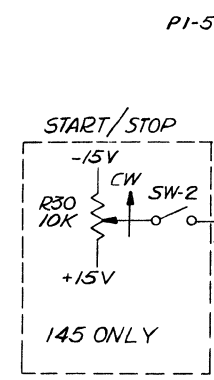

PULSE AMPLIFIER (145 ONLY)

FUNCTION SELECTOR

NOTE: UNLESS OTHERWISE SPECIFIED

REMOVE ALL BURRS AND BREAK SHARP EDGES	DRAWN	DATE	WAVETEK SAN DIEGO • CALIFORNIA
MATERIAL	PROJECT		
FINISH WAVETEK PROCESS	REVISION APPROV		TITLE
			SCHEMATIC GENERATOR BOARD
			TOLERANCE UNLESS OTHERWISE SPECIFIED XXX - 010 ANGLES 1 XX - 030
			DO NOT SCALE DWG
SCALE	MODEL NO	DWG NO	REV
	145-S-620	1104-00-3245	A
COUNT	23338	SHEET	3 OF 4

THIS DOCUMENT CONTAINS PROPRIETARY INFORMATION AND DESIGN RIGHTS BELONGING TO WAVETEK AND MAY NOT BE REPRODUCED FOR ANY REASON EXCEPT CALIBRATION, OPERATION, AND MAINTENANCE WITHOUT WRITTEN AUTHORIZATION.

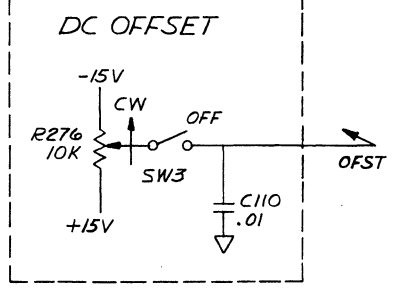
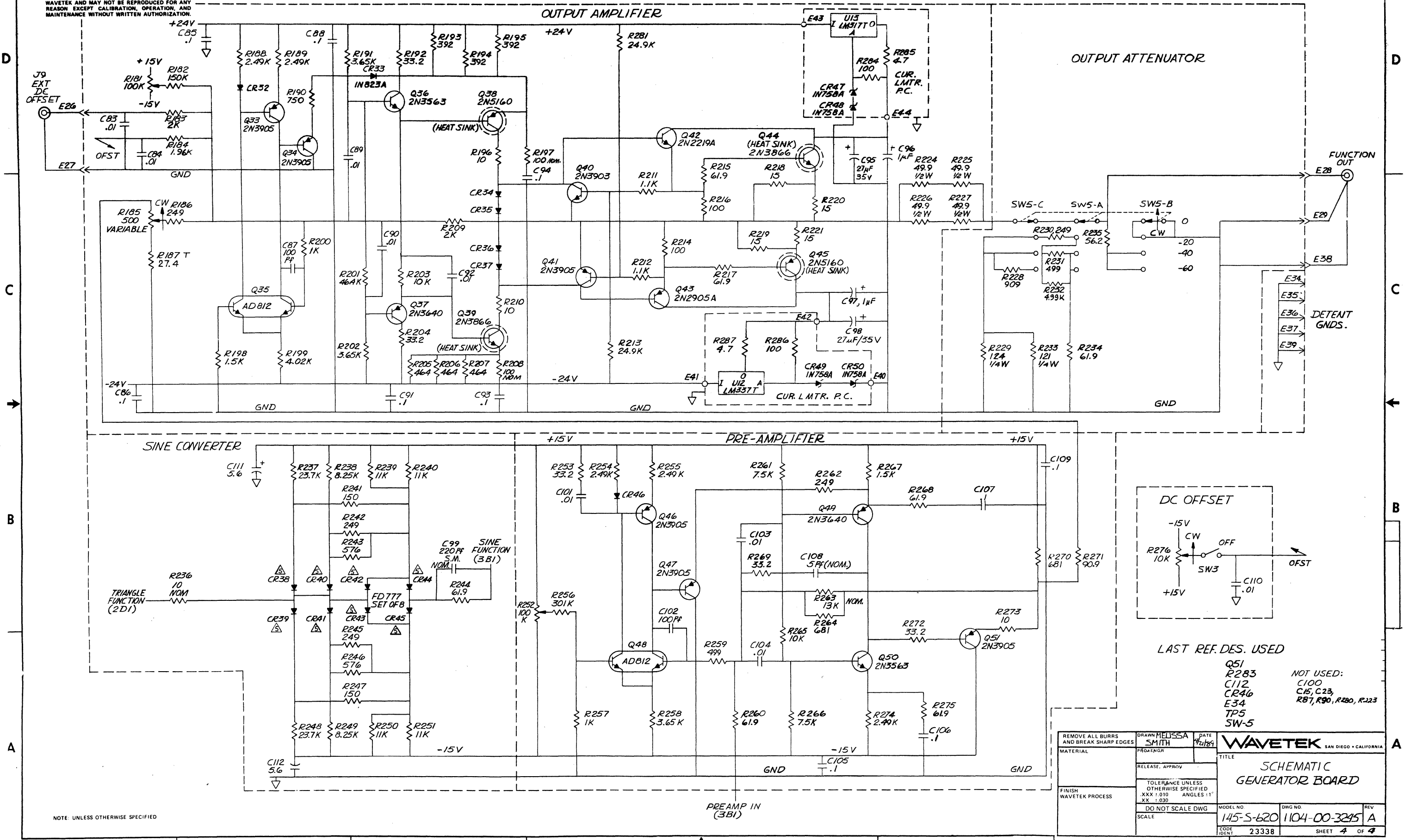

- LAST REF. DES. USED
- Q51
 - R283
 - C112
 - CR46
 - E34
 - TP5
 - SW-5
- NOT USED:
- C100
 - C15, C23
 - R87, R90, R280, R223

NOTE: UNLESS OTHERWISE SPECIFIED

REMOVE ALL BURRS AND BREAK SHARP EDGES	DRAWN MELISSA SMITH	DATE 7/21/84	WAVETEK SAN DIEGO • CALIFORNIA	
MATERIAL	PROJEENGR		TITLE	
	RELEASE: APPROV		SCHEMATIC GENERATOR BOARD	
FINISH WAVETEK PROCESS	TOLERANCE UNLESS OTHERWISE SPECIFIED XXX : 010 ANGLES : 1° XX : 030	DO NOT SCALE DWG	MODEL NO. 145-5-620	DWG NO. 1104-00-3245
	SCALE		REV A	
	CODE IDENT 23338		SHEET 4	OF 4

THIS DOCUMENT CONTAINS PROPRIETARY INFORMATION AND DESIGN RIGHTS BELONGING TO WAVETEK AND MAY NOT BE REPRODUCED FOR ANY REASON EXCEPT CALIBRATION, OPERATION, AND MAINTENANCE WITHOUT WRITTEN AUTHORIZATION

REV	ECO	BY	DATE	APP
A	ECO # 89-262	MS	1/24/89	DPM

D
C
B
A

D
C
B
A

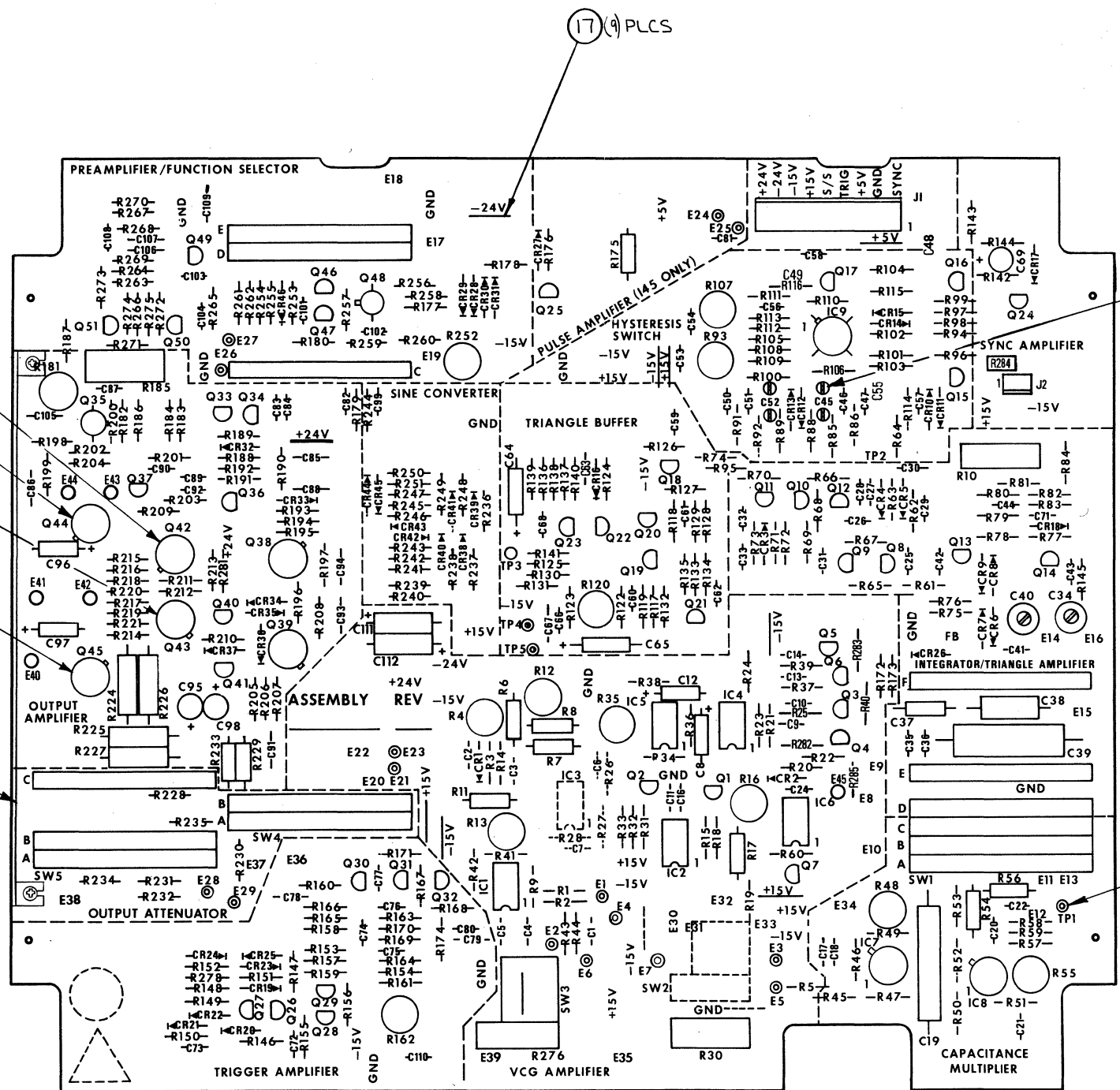

FOR INSTALLATION
SEE SHT 3 of 3
(REF: #12)

1 TURN TO FULL COUNTER CLOCKWISE POSITION THEN TURN BACK COUNTER CLOCKWISE ONE POSITION TO INSTALL BOTH STOPS.

NOTE UNLESS OTHERWISE SPECIFIED

REMOVE ALL BURRS AND BREAK SHARP EDGES	DRAWN MELISSA SMITH	DATE 1/24/89	WAVETEK SAN DIEGO 4 CALIFORNIA
MATERIAL	CHECKED D. BULLER	DATE 1/24/89	
FINISH WAVETEK PROCESS	PROJ ENGR V. J. J.	DATE 6/89	TITLE ASSEMBLY GENERATOR BOARD
	RELEASE APPROV. V. J. J.	DATE 6/89	
DO NOT SCALE DRAWING	UNLESS OTHERWISE SPECIFIED DIMENSIONS ARE IN INCHES FRACTIONS DECIMALS ANGLES	SIZE D	FSCM NO. 23338
		DWG. NO. 1101-00-3245	REV A
		SCALE	MODEL 145-S-620 SHEET 1 OF 3

THIS DOCUMENT CONTAINS PROPRIETARY INFORMATION AND DESIGN RIGHTS BELONGING TO WAVETEK AND MAY NOT BE REPRODUCED FOR ANY REASON EXCEPT CALIBRATION, OPERATION, AND MAINTENANCE WITHOUT WRITTEN AUTHORIZATION.

D
C
B
A

D
C
B
A

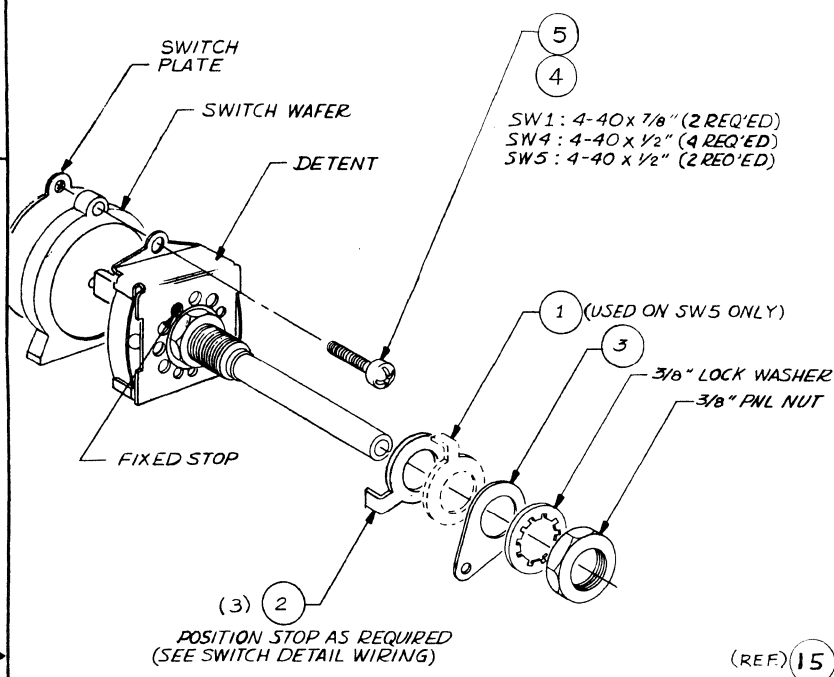

TYPICAL HARDWARE STACK-UP

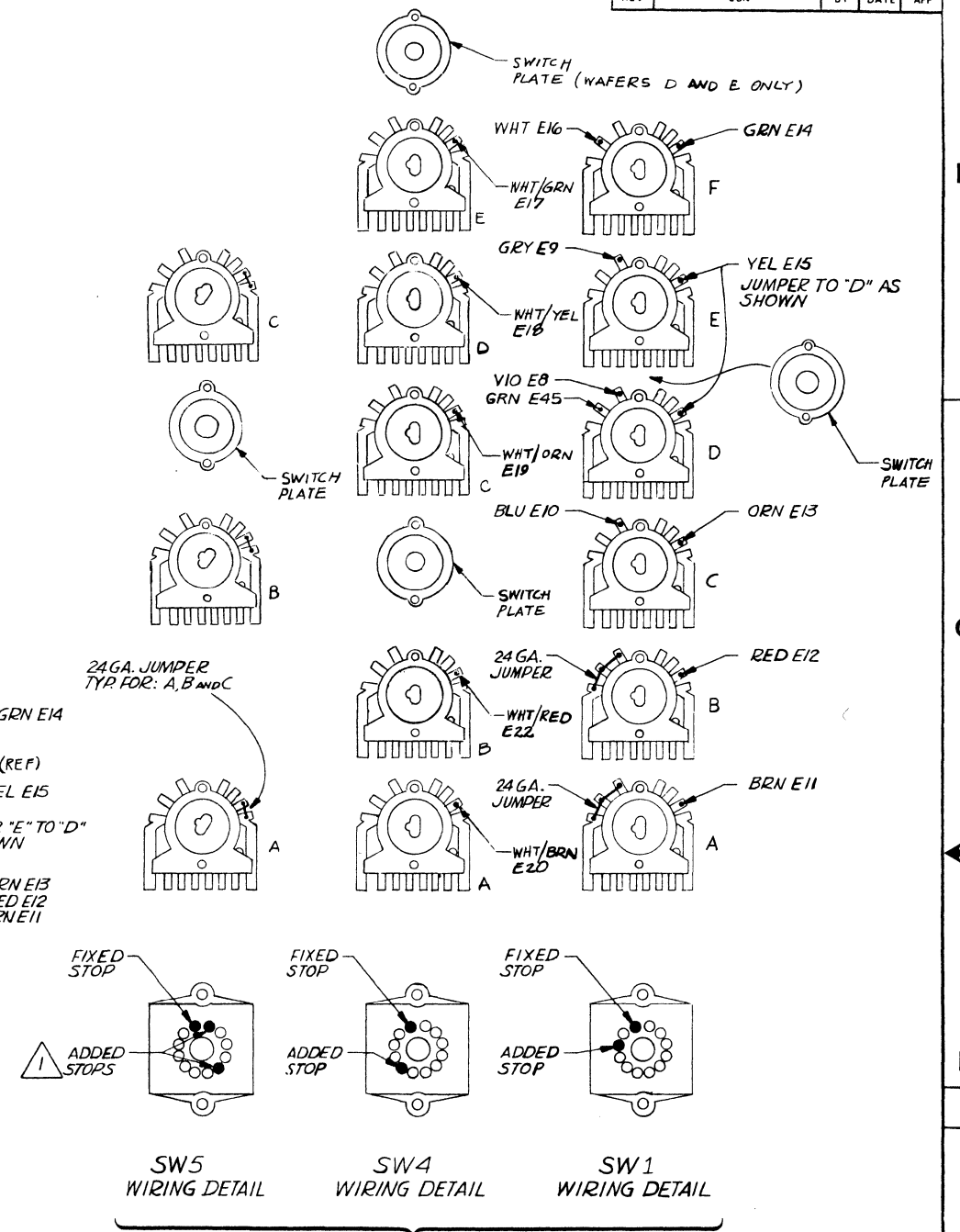
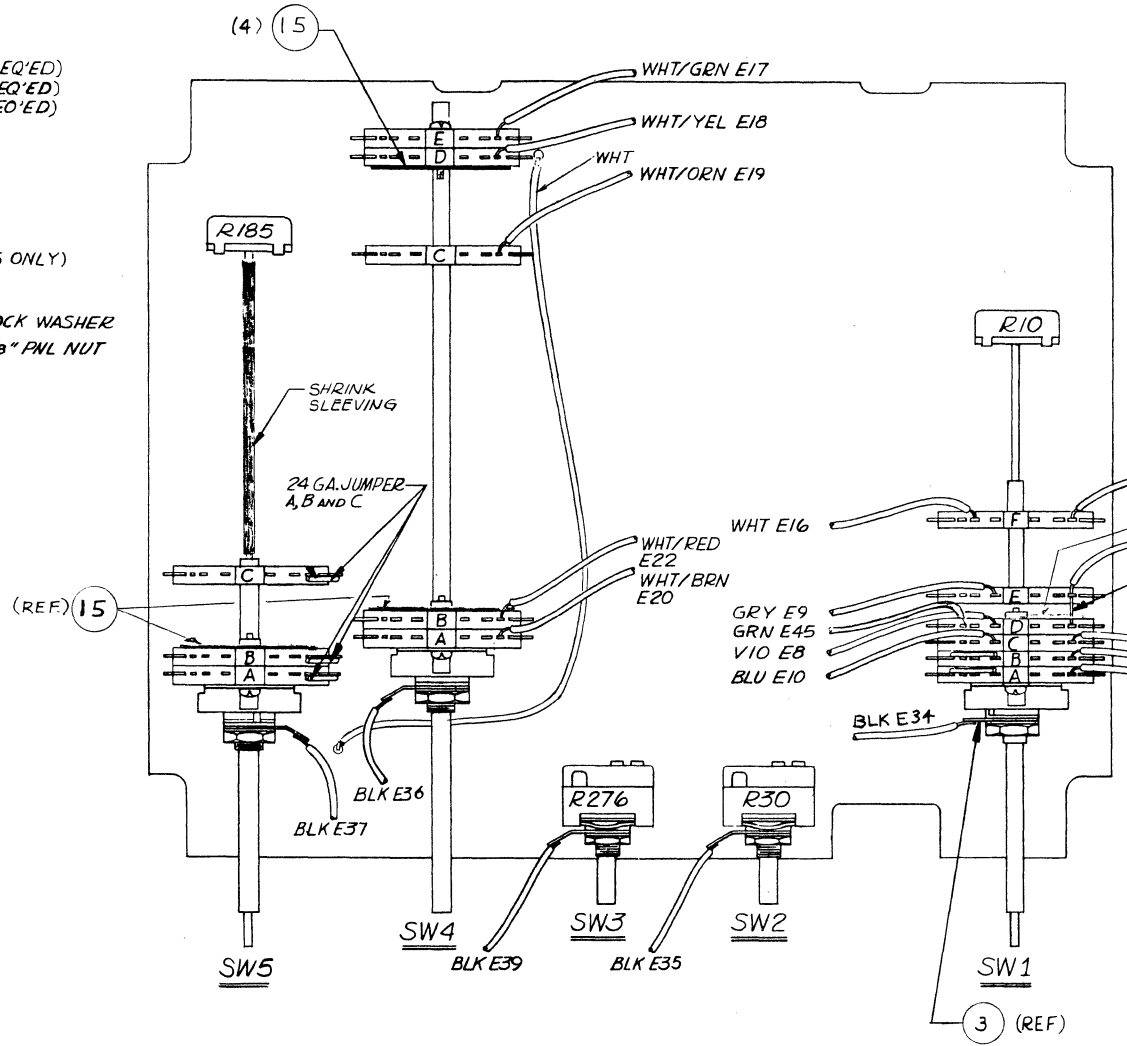

DETENT SHOWN FROM FRONT VIEW IN FULL COUNTER CLOCKWISE POSITION

NOTE: UNLESS OTHERWISE SPECIFIED

REMOVE ALL BURRS AND BREAK SHARP EDGES	DRAWN: MELISSA SMITH	DATE: 4/21/89	WAVETEK SAN DIEGO • CALIFORNIA	
MATERIAL: #	PROJ ENGR:	RELEASE APPROV:	TITLE: ASSEMBLY GENERATOR BOARD	
FINISH: WAVETEK PROCESS	TOLERANCE UNLESS OTHERWISE SPECIFIED XXX .010 ANGLES .1 XX .030		MODEL NO: 145-S-620	DWG NO: 1101-00-3245
	DO NOT SCALE DWG	SCALE:	REV: A	CODE IDENT: 23338
			SHEET 2 OF 3	

THIS DOCUMENT CONTAINS PROPRIETARY INFORMATION AND DESIGN RIGHTS BELONGING TO WAVETEK AND MAY NOT BE REPRODUCED FOR ANY REASON EXCEPT CALIBRATION, OPERATION, AND MAINTENANCE WITHOUT WRITTEN AUTHORIZATION.

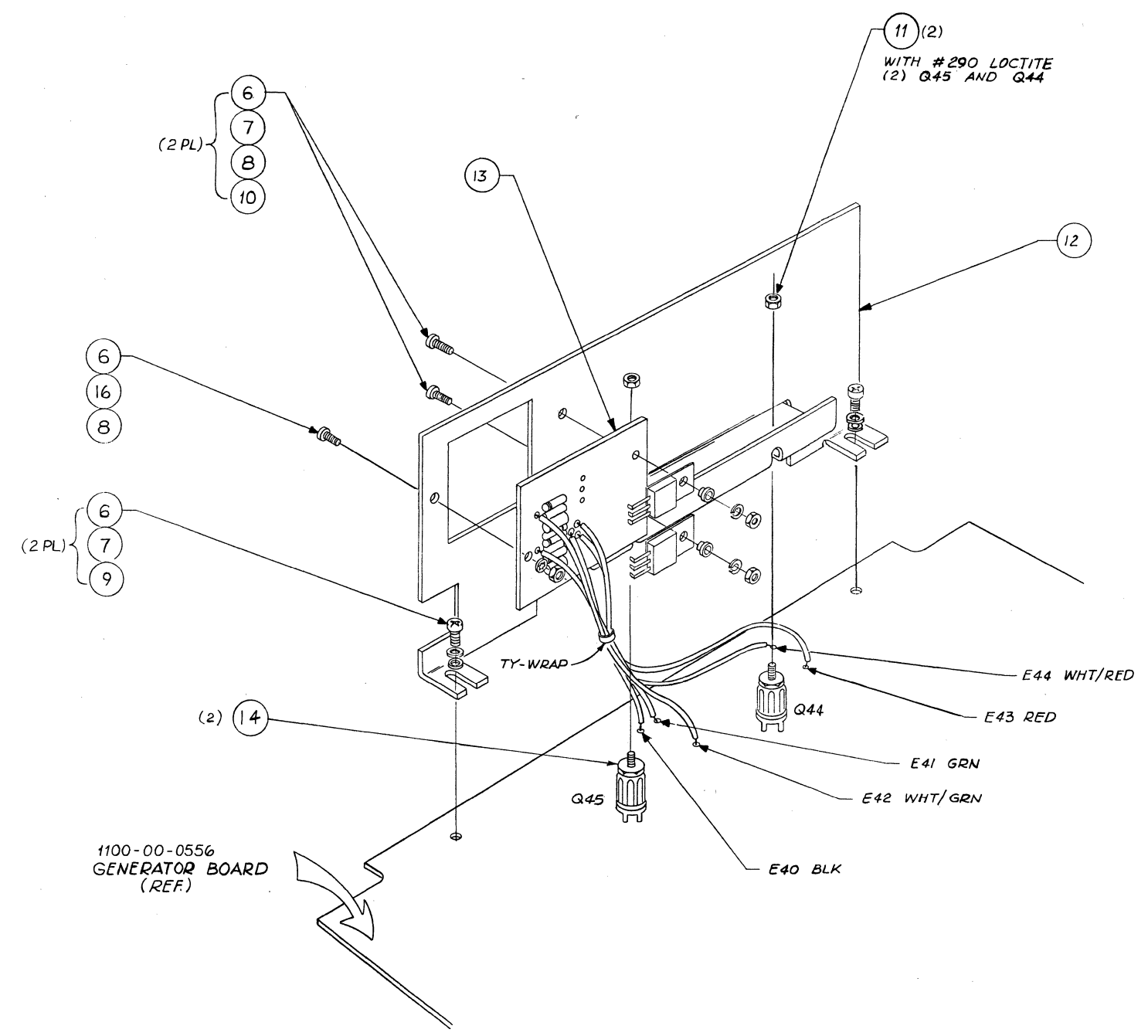

1100-00-0556
GENERATOR BOARD
(REF.)

NOTE: UNLESS OTHERWISE SPECIFIED

REMOVE ALL BURRS AND BREAK SHARP EDGES	DRAWN MELISSA SMITH PROJ ENGR	DATE 2/28/81	WAVETEK SAN DIEGO • CALIFORNIA	
MATERIAL	RELEASE APPROV	TITLE ASSEMBLY GENERATOR BOARD		
FINISH WAVETEK PROCESS	TOLERANCE UNLESS OTHERWISE SPECIFIED .XXX - .010 ANGLES .1 XX - .030	DO NOT SCALE DWG	MODEL NO 145-S-620	DWG NO 1101-00-3245
SCALE		SCALE	CODE IDENT 23338	REV A
			SHEET 3 OF 3	

THIS DOCUMENT CONTAINS PROPRIETARY INFORMATION AND DESIGN RIGHTS BELONGING TO WAVETEK AND MAY NOT BE REPRODUCED FOR ANY REASON EXCEPT CALIBRATION, OPERATION, AND MAINTENANCE WITHOUT WRITTEN AUTHORIZATION.

REV ECO BY DATE APP

REFERENCE DESIGNATORS	PART DESCRIPTION	DRG-MFGR-PART-NO	MFGR	WAVETEK NO.	QTY/PT
NONE	A/D GENERATOR BD 145-5-620	1101-00-3245	WVTK	1101-00-3245	1
NONE	SCHEMATIC GENERATOR BD 145-5-620	1104-00-3245	WVTK	1104-00-3245	1
13	PCA CURRENT LIMITER	143-1008	WVTK	1208-00-1008	1
NONE	KIT, PRE WAVE LOAD 145-3245	1208-00-3246	WVTK	1208-00-3246	1
C49	CAP. CER. 56PF, 1KV	DD-560	CRL	1500-05-6001	1
C37 38 39	CAP SET, POLYCY MIXED MATCHED SET	1509-80-0008	BISHD	1509-80-0008	1
J1	CONN, 9PIN	09-60-1091	MOLEX	2100-02-0052	1
18	SOCKET, MINISERT	75060-012	BERO	2100-03-0076	4
NONE	KNOB STD	RB-67-1-SB-M	ROGAN	2400-01-0008	3
NONE	COAX KNOB SET	RB-67-1-SB+O-M-9	ROGAN	2400-01-0009	2
NONE	SUPER KIT	2500-0145-01	WVTK	2500-0145-01	1
NONE	HEAT SINK	207	WAKE	2800-11-0001	2
NONE	TRANSIPAD	531-218	BIVAR	2800-11-0004	2
14	HEATSINK	2606SH5E	WAKE	2800-11-0012	2
11	NUT, MACHINE SCREW,	NAS 671C6	CMRCL	2800-50-6100	2

WAVETEK PARTS LIST
 TITLE PCA, GENERATOR BD 145-5-620
 ASSEMBLY NO. 1100-00-3245
 PAGE 1
 REV B

REFERENCE DESIGNATORS	PART DESCRIPTION	DRG-MFGR-PART-NO	MFGR	WAVETEK NO.	QTY/PT
NONE	ASSY DRWG, CURRENT LIMITER BOARD	0101-00-1008	WVTK	0101-00-1008	1
NONE	SCHEMATIC GENERATOR	0103-00-0556	WVTK	0103-00-0556	1
12	HEATSINK BRACKET	143-5083	WVTK	1400-01-5083	1
NONE	CURRENT LIMITER BD REF: SPEC 0008-00-0455 REV C	143-1008	WVTK	1700-00-1008	1
10	WASHER	5607-150	SESTM	2800-11-0015	2
7	WASHER, LOCK REG, S/S #4	MS 35338-135	CMRCL	2800-45-4000	2
16	LOCK WASHER, INTERNAL TOOTH, SS #4	MS 35333-70	CMRCL	2800-45-4001	1
6	SCREW PLPS PAN M/S 18-B S/S 4-40X3/8	MS 51957-15	CMRCL	2800-48-4106	3
8	NUT, MACHINE SCREW, 18-B SS, #4-40	NAS 671C4	CMRCL	2800-50-4100	3
R285 R287	RES. C, 1/2W, 5%, 4.7	RC-1/2-4R7J	STKPL	4700-25-0479	2
R284 R286	RES. MF, 1/8W, 1%, 100	RN55D-1000F	TRW	4701-03-1000	2
CR47 CR48 CR49 CR50	DIODE, ZENER, 10V	1N758A	FAIR	4801-01-0758	4
U13	VOLT REGULATOR, 3 TERMINAL ADJUSTABLE	LM317T	NSC	7000-03-1700	1

WAVETEK PARTS LIST
 TITLE PCA, CURRENT LIMITER
 ASSEMBLY NO. 1208-00-1008
 PAGE 1
 REV B

REFERENCE DESIGNATORS	PART DESCRIPTION	DRG-MFGR-PART-NO	MFGR	WAVETEK NO.	QTY/PT
NONE	ASSY DRWG GENERATOR	0101-00-0556	WVTK	0101-00-0556	1
NONE	SCHEMATIC GENERATOR	0103-00-0556	WVTK	0103-00-0556	1
C55	CAP. CER, 5PF, 1KV	DD-050 LDNG LEAD	CRL	1500-00-5001	1
C108T C61 C76 C77	CAP. CER DISK, 5PF, 1KV, 10%	0311-00018	WVTK	1500-00-5011	4
C59 C82	CAP. CER, 10PF, 1KV	DD-100	CRL	1500-01-0011	2
C102 C87	CAP. CER, 100PF, 1KV	DD-101	CRL	1500-01-0111	2
C13 C22 C9	CAP. CER, .001UF, 1KV	DD-102	CRL	1500-01-0211	3
C1 C101 C103 C104 C11 C110 C16 C17 C18 C20 C21 C24 C27 C29 C3 C30 C32 C33 C4 C42 C43 C44 C5 C53 C54 C56 C57 C58 C6 C60 C62 C63 C66 C68 C7 C71 C72 C73 C74 C75 C80 C81 C83 C84 C89 C90 C92	CAP CER MDN .01MF 50V, AXIAL	CAC025U103Z100A	CORNG	1500-01-0310	47
C105 C106 C107 C109 C67 C78 C79 C85 C86 C88 C91 C93 C94	CAP. CER, MDN, .1MF, 50V, AXIAL	CAC0325U104Z050A	CORNG	1500-01-0405	13
C2	CAP. CER, 150PF, 1KV	DD-151	CRL	1500-01-5111	1
C10 C14	CAP. CER, 330PF, 1KV	DD-331	CRL	1500-03-3111	2
C26	CAP. MICA, 100PF, 500V	DM15-101J	ARCO	1500-11-0100	1
C25	CAP. MICA, 15PF, 500V	DM15-150J	ARCO	1500-11-5000	1

WAVETEK PARTS LIST
 TITLE KIT, PRE WAVE LOAD 145-3245
 ASSEMBLY NO. 1208-00-3246
 PAGE 1
 REV A

REFERENCE DESIGNATORS	PART DESCRIPTION	DRG-MFGR-PART-NO	MFGR	WAVETEK NO.	QTY/PT
Q44	18-B SS, #6-32 SMALL PATTERN				
Q45	TRANS	2N3866	MOT	4901-03-8660	1
	TRANS	2N5160-18	MOT	4901-05-1600	1

WAVETEK PARTS LIST
 TITLE PCA, GENERATOR BD 145-5-620
 ASSEMBLY NO. 1100-00-3245
 PAGE 2
 REV B

REFERENCE DESIGNATORS	PART DESCRIPTION	DRG-MFGR-PART-NO	MFGR	WAVETEK NO.	QTY/PT
U12	POS VOLT REGULATOR	LM337T	NSC	7000-03-3700	1

WAVETEK PARTS LIST
 TITLE PCA, CURRENT LIMITER
 ASSEMBLY NO. 1208-00-1008
 PAGE 2
 REV B

REFERENCE DESIGNATORS	PART DESCRIPTION	DRG-MFGR-PART-NO	MFGR	WAVETEK NO.	QTY/PT
C28 C31 C99T	CAP. MICA, 220PF, 500V, RADIAL	DM15-221J	ARCO	1500-12-2100	3
C41T	CAP. MICA, 30PF, 500V, RADIAL	DM15-300J	ARCO	1500-13-0000	1
C46 C51	CAP. MICA, 47PF, 500V	DM15-470J	ARCO	1500-14-7000	2
C47 C50 NONE	CAP. MICA, 68PF, 500V	DM15-680J	ARCO	1500-16-8000	3
C36	CAP. MICA, 820PF, 300V	DM15-821F	ARCO	1500-18-2101	1
C69	CAP. ELECT, 22MF, 25V, RADIAL	SRA25VB22RM6X7LL	UNCON	1500-32-2002	1
C19	CAP. POLYCY, 1MF, 100V, AXIAL	B1A105F	ELPAC	1500-41-0504	1
C34 C40	CAP. VAR, 3.5-13PF, 250V	75-TRIKO-02 3.5/13PF	TRIKO	1500-51-3000	2
C12 C8 C96 C97	CAP. TANT, 1MF, 35V	150D105X9035A2	SPRAG	1500-71-0502	4
C95 C98	CAP. TANT 27UF, 35V+/-10%, 0.25LS	199D276X9035FE4	SPRAG	1500-72-7602	2
C111 C112 C64 C65	CAP. TANT, 5.6MF, 35V	150D565X9035B2	SPRAG	1500-75-6502	4
NONE	GENERATOR REF: SPEC 0008-00-0455 REV C	145-0556	WVTK	1700-00-0556	1
NONE	PIN, MALE	60809-2	AMP	2100-05-0020	20

WAVETEK PARTS LIST
 TITLE KIT, PRE WAVE LOAD 145-3245
 ASSEMBLY NO. 1208-00-3246
 PAGE 2
 REV A

NOTE: UNLESS OTHERWISE SPECIFIED

REMOVE ALL BURRS AND BREAK SHARP EDGES	DRAWN	DATE	
MATERIAL	CHECKED		
	PROJ ENGR		
	RELEASE APPROV.		
FINISH WAVETEK PROCESS	UNLESS OTHERWISE SPECIFIED DIMENSIONS ARE IN INCHES FRACTIONS DECIMALS ANGLES		TITLE PARTS LIST PCA, GENERATOR
DO NOT SCALE DRAWING	SIZE	FSCM NO.	DWG. NO.
	D	23338	1100-00-3245
	SCALE	145-S-620	SHEET 1 OF 3

THIS DOCUMENT CONTAINS PROPRIETARY INFORMATION AND DESIGN RIGHTS BELONGING TO WAVETEK AND MAY NOT BE REPRODUCED FOR ANY REASON EXCEPT CALIBRATION, OPERATION, AND MAINTENANCE WITHOUT WRITTEN AUTHORIZATION.

REV ECO BY DATE APP

REFERENCE DESIGNATORS	PART DESCRIPTION	ORIG-MFGR-PART-NO	MFGR	WAVETEK NO.	QTY/PT
NONE	TRANSIPAD	10123N	METRS	2800-11-0003	2
NONE	TRANSIPAD	531-218	BIVAR	2800-11-0004	2
FB1	FERRITE BEAD	56-590-65/3B	FERRX	3100-00-0001	1
R4 R48	POT. TRIM. 1K	91AR1K	BECK	4600-01-0209	2
R12 R162 R55	POT. TRIM. 10K	91AR10K	BECK	4600-01-0315	3
R13 R16 R181 R252	POT. TRIM. 100K	91AR100K	BECK	4600-01-0402	4
R120	POT. TRIM. 200	91AR200	BECK	4600-02-0101	1
R107 R35 R93	POT. TRIM. 500	91AR500	BECK	4600-05-0104	3
R11 R8	RES. C. 1/2W. 10X. 5. 1M	RC-1/2-515J	STKPL	4700-25-5104	2
R17	RES. C. 1/2W. 10X. 6. 8M			4700-25-6804	1
R118 R124 R127 R128 R129 R142 R145 R149 R153 R158 R174 R180 R214 R216 R49 R57 R73	RES. MF. 1/BW. 1X. 100	RN55D-1000F	TRW	4701-03-1000	17
R104 R108 R111 R155 R165 R168 R200 R257 R45 R47 R51 R94 R98 R99	RES. MF. 1/BW. 1X. 1K	RN55D-1001F	TRW	4701-03-1001	14
R112 R146 R203 R265 R41	RES. MF. 1/BW. 1X. 10K	RN55D-1002F	TRW	4701-03-1002	5
R116 R123 R139 R141 R172	RES. MF. 1/BW. 1X. 10	5043ED10R100F	MEPCO	4701-03-1009	18

WAVETEK PARTS LIST TITLE KIT, PRE WAVE LOAD 145-3245 ASSEMBLY NO. 1208-00-3246 REV A PAGE 3

REFERENCE DESIGNATORS	PART DESCRIPTION	ORIG-MFGR-PART-NO	MFGR	WAVETEK NO.	QTY/PT
R166 R170	RES. MF. 1/BW. 1X. 21. 5	RN55D-21R5F	TRW	4701-03-2159	2
R237 R248	RES. MF. 1/BW. 1X. 23. 7K	RN55D-2372F	TRW	4701-03-2372	2
R102 R137 R144 R159 R186 R230 R242 R245 R25 R262 R39	RES. MF. 1/BW. 1X. 249	RN55D-2490F	TRW	4701-03-2490	11
R147 R151 R156 R171 R188 R189 R19 R254 R255 R274 R278 R33	RES. MF. 1/BW. 1X. 2. 49K	RN55D-2491F	TRW	4701-03-2491	12
R161 R213 R281 R283	RES. MF. 1/BW. 1X. 24. 9K	RN55D-2492F	TRW	4701-03-2492	4
R187T	RES. MF. 1/BW. 1X. 27. 4	RN55D-27R4F	TRW	4701-03-2749	1
R150 R177 R178 R43	RES. MF. 1/BW. 1X. 3. 01K	RN55D-3011F	TRW	4701-03-3011	4
R131 R256	RES. MF. 1/BW. 1X. 301K	RN55D-3013F	TRW	4701-03-3013	2
R134 R67 R71 R88 R89	RES. MF. 1/BW. 1X. 316	RN55D-3160F	TRW	4701-03-3160	5
R101 R103 R109 R110 R119 R126 R130 R140 R192 R204 R253 R269 R272 R65 R68 R69 R72 R75 R76 R79 R82 R95	RES. MF. 1/BW. 1X. 33. 2	RN55D-33R2F	TRW	4701-03-3329	22
R100T R105T	RES. MF. 1/BW. 1X. 3. 57K	RN55D-3571F	TRW	4701-03-3571	2
R191 R202 R258 R80 R83	RES. MF. 1/BW. 1X. 3. 65K	RN55D-3651F	TRW	4701-03-3651	5
R115 R193 R194 R195	RES. MF. 1/BW. 1X. 392	RN55D-3920F	TRW	4701-03-3920	4
R199 R42	RES. MF. 1/BW. 1X. 4. 02K	RN55D-4021F	TRW	4701-03-4021	2

WAVETEK PARTS LIST TITLE KIT, PRE WAVE LOAD 145-3245 ASSEMBLY NO. 1208-00-3246 REV A PAGE 5

REFERENCE DESIGNATORS	PART DESCRIPTION	ORIG-MFGR-PART-NO	MFGR	WAVETEK NO.	QTY/PT
R133 R136 R138 R160 R164 R261 R266 R77 R78	RES. MF. 1/BW. 1X. 7. 5K	RN55D-7501F	TRW	4701-03-7501	9
R154	RES. MF. 1/BW. 1X. 76. 8K	RN55D-7682F	TRW	4701-03-7682	1
R125	RES. MF. 1/BW. 1X. 825	RN55D-8250F	TRW	4701-03-8250	1
R238 R249 R58	RES. MF. 1/BW. 1X. 8. 25K	RN55D-8251F	TRW	4701-03-8251	3
R197T R208T R59	RES. MF. 1/BW. 1X. 82. 5	RN55D-82R5F	TRW	4701-03-8259	3
R122 R228	RES. MF. 1/BW. 1X. 909	RN55D-9090F	TRW	4701-03-9090	2
R271	RES. MF. 1/BW. 1X. 90. 9	RN55D-90R9F	TRW	4701-03-9099	1
R7	RES. MF. 1/4W. 1X. 1M	RN60D-1004F	TRW	4701-13-1004	1
R233	RES. MF. 1/4W. 1X. 121	RN60D-1210F	TRW	4701-13-1210	1
R229	RES. MF. 1/4W. 1X. 124	RN60D-1240F	TRW	4701-13-1240	1
R175	RES. MF. 1/4W. 1X. 49. 9	RN60D-49R9F	TRW	4701-13-4999	1
R6T	RES. MF. 1/4W. 1X. 698K	RN60D-6983F	TRW	4701-13-6983	1
R224 R225 R226 R227	RES. MF. 1/2W. 1X. 49. 9	RN65D-49R9F	TRW	4701-23-4999	4
R52 R53 R54	RES. MF. MIXED SET	4789-00-0043	IRC	4789-00-0043	1
R56	RES. MF. .6M. 1X. 10M	ML-181	CADDD	4799-00-0003	1
17	RES. 0 OHM JUMPER	JP02T680	ROHM	4799-00-0087	10

WAVETEK PARTS LIST TITLE KIT, PRE WAVE LOAD 145-3245 ASSEMBLY NO. 1208-00-3246 REV A PAGE 7

REFERENCE DESIGNATORS	PART DESCRIPTION	ORIG-MFGR-PART-NO	MFGR	WAVETEK NO.	QTY/PT
R173 R196 R210 R236T R24 R273 R38 R50 R61 R64 R74 R81 R84					
R211 R212	RES. MF. 1/BW. 1X. 1. 1K	RN55D-1101F	TRW	4701-03-1101	2
R239 R240 R250 R251	RES. MF. 1/BW. 1X. 11K	RN55D-1102F	TRW	4701-03-1102	4
R96 R97	RES. MF. 1/BW. 1X. 1. 21K	RN55D-1211F	TRW	4701-03-1211	2
R114 R241 R247 R66	RES. MF. 1/BW. 1X. 150	RN55D-1500F	TRW	4701-03-1500	4
R113 R176 R18 R198 R23 R267 R32 R36 R62 R63 R9	RES. MF. 1/BW. 1X. 1. 5K	RN55D-1501F	TRW	4701-03-1501	11
R132 R163 R2	RES. MF. 1/BW. 1X. 15K	RN55D-1502F	TRW	4701-03-1502	3
R182	RES. MF. 1/BW. 1X. 150K	RN55D-1503F	TRW	4701-03-1503	1
R218 R219 R220 R221	RES. MF. 1/BW. 1X. 15	RN55D-15R0F	TRW	4701-03-1509	4
R263T	RES. MF. 1/BW. 1X. 17. 4K	RN55D-1742F	TRW	4701-03-1742	1
R169	RES. MF. 1/BW. 1X. 1. 78K	RN55D-1781F	TRW	4701-03-1781	1
R184	RES. MF. 1/BW. 1X. 1. 96K	RN55D-1961F	TRW	4701-03-1961	1
R179	RES. MF. 1/BW. 1X. 200	RN55D-2000F	TRW	4701-03-2000	1
R1 R15 R183 R209 R28 R31	RES. MF. 1/BW. 1X. 2K	RN55D-2001F	TRW	4701-03-2001	6
R143	RES. MF. 1/BW. 1X. 215	RN55D-2150F	TRW	4701-03-2150	1

WAVETEK PARTS LIST TITLE KIT, PRE WAVE LOAD 145-3245 ASSEMBLY NO. 1208-00-3246 REV A PAGE 4

REFERENCE DESIGNATORS	PART DESCRIPTION	ORIG-MFGR-PART-NO	MFGR	WAVETEK NO.	QTY/PT
R106 R205 R206 R207	RES. MF. 1/BW. 1X. 464	RN55D-4640F	TRW	4701-03-4640	4
R201	RES. MF. 1/BW. 1X. 46. 4K	RN55D-4642F	TRW	4701-03-4642	1
R5	RES. MF. 1. 8W. 1X. 46. 4	RN55D-46R4F	TRW	4701-03-4649	1
R34	RES. MF. 1/BW. 1X. 4. 75K	RN55D-4751F	TRW	4701-03-4751	1
R231 R259	RES. MF. 1/8. 1X. 499	RN55D-4990F	TRW	4701-03-4990	2
R117 R14 R152 R20 R22 R232 R26 R27 R3 R37	RES. MF. 1/BW. 1X. 4. 99K	RN55D-4991F	TRW	4701-03-4991	10
R157	RES. MF. 1/BW. 1X. 49. 9K	RN55D-4992F	TRW	4701-03-4992	1
R85T R92T	RES. MF. 1/BW. 1X. 54. 9	RN55D-54R9F	TRW	4701-03-5499	2
R235	RES. MF. 1/BW. 1X. 56. 2	RN55D-56R2F	TRW	4701-03-5629	1
R148T R243 R246	RES. MF. 1/BW. 1X. 576	RN55D-5760F	TRW	4701-03-5760	3
R21 R40 R44 R86 R91	RES. MF. 1/BW. 1X. 604	RN55D-6040F	TRW	4701-03-6040	5
R215 R217 R234 R244 R260 R268 R275	RES. MF. 1/BW. 1X. 61. 9	RN55D-61R9F	TRW	4701-03-6199	7
R264 R270	RES. MF. 1/BW. 1X. 681	RN55D-6810F	TRW	4701-03-6810	2
R46	RES. MF. 1/BW. 1X. 6. 98K	RN55D-6981F	TRW	4701-03-6981	1
R135 R167 R190 R60 R70	RES. MF. 1/BW. 1X. 750	RN55D-7500F	TRW	4701-03-7500	5

WAVETEK PARTS LIST TITLE KIT, PRE WAVE LOAD 145-3245 ASSEMBLY NO. 1208-00-3246 REV A PAGE 6

REFERENCE DESIGNATORS	PART DESCRIPTION	ORIG-MFGR-PART-NO	MFGR	WAVETEK NO.	QTY/PT
CR3 CR33 CR4 CR5	DIODE, ZENER, 6. 2V, 1W823	1N823A	MDT	4801-01-0823	4
CR16	DIODE, REFERENCE, LOW LEVEL, TEMP COMP	1N4581	MICRO	4801-01-4581	1
CR19 CR28 CR29 CR30 CR31 CR6 CR7 CR8 CR9	DIODE, ULTRA FAST	1N4244	T/CSF	4807-02-0777	9
CR1 CR10 CR11 CR14 CR15 CR17 CR18 CR20 CR21 CR22 CR23 CR24 CR25 CR27 CR32 CR34 CR35 CR36 CR37 CR46	DIODE 1N4148 COMPUTER, G/P, 75V, 200M A, SWITCHING	1N4148	FAIR	4807-02-6666	20
CR12 CR13	DIODE 5082-2811 SCHOTTKY, 15V, 20MA	5082-2811	HP	4809-02-2811	2
CR2 26	DIODE, M/PR, FD-777 QTY: 2: 4807-02-0777	4898-00-0004	KLQ	4898-00-0004	1
CR38 39 40 41 42 43 44 45	DIODE, SET, 8-FD-777 QTY: 8: 4807-02-0777	4898-00-0010	KLQ	4898-00-0010	1
G42	TRANS 2N2219A NPN GENERAL PURPOSE TO-5	2N2219A	NSC	4901-02-2191	1
G43	TRANS 2N2905A PNP GENERAL PURPOSE TO-5	2N2905A	NSC	4901-02-9051	1
G12 G36 G50	TRANS, NPN, TO-92	2N3563	FAIR	4901-03-5630	3
G15 G16 G37 G49	TRANS, PNP, TO-92	MPS3640	MDT	4901-03-6400	4

WAVETEK PARTS LIST TITLE KIT, PRE WAVE LOAD 145-3245 ASSEMBLY NO. 1208-00-3246 REV A PAGE 8

NOTE: UNLESS OTHERWISE SPECIFIED

REMOVE ALL BURRS AND BREAK SHARP EDGES	DRAWN	DATE	WAVETEK SAN DIEGO • CALIFORNIA
MATERIAL	CHECKED		
	PROJ. ENGR.		
	RELEASE APPROV.		
FINISH WAVETEK PROCESS	UNLESS OTHERWISE SPECIFIED DIMENSIONS ARE IN INCHES TOLERANCES ARE: FRACTIONS DECIMALS ANGLES XX ± XXX ±		TITLE PARTS LIST PCA, GENERATOR
DO NOT SCALE DRAWING	SIZE D 23338	PSCM NO. 1100-00-3245	DWG. NO. 1100-00-3245
	SCALE 145-S-620	SHEET 2 OF 3	REV B

115885
 THIS DOCUMENT CONTAINS PROPRIETARY INFORMATION AND DESIGN RIGHTS BELONGING TO WAVETEK AND MAY NOT BE REPRODUCED FOR ANY REASON EXCEPT CALIBRATION, OPERATION, AND MAINTENANCE WITHOUT WRITTEN AUTHORIZATION.

REV ECO BY DATE APP

REFERENCE DESIGNATORS	PART DESCRIPTION	DR10-MFGR-PART-NO	MFGR	WAVETEK NO.	QTY/PT
Q39	TRANS	2N3866	MDT	4901-03-8660	1
Q13 Q21 Q22 Q25 Q27 Q28 Q29 Q31 Q40 Q6	TRANS, GENERAL PURPOSE, NPN, TO-92	2N3903	NSC	4901-03-9030	10
Q10 Q11 Q14 Q17 Q19 Q23 Q24 Q26 Q30 Q32 Q33 Q34 Q4 Q41 Q46 Q47 Q51	TRANS, GENERAL PURPOSE, PNP, TO-92	2N3905	ITT	4901-03-9050	17
Q38	TRANS	2N5160-18	MDT	4901-05-1600	1
Q3	TRANS, P-CHANNEL JFETS	2N5460	MDT	4901-05-4600	1
Q5	TRANS, N-CHANNEL JFETS	2N5485	MDT	4901-05-4850	1
Q1	TRANS N-CHANNEL JFETS	2N5486	MDT	4901-05-4860	1
Q18 20	TRANS, M/PR, 2N3563 QTY: 2: 4901-03-5630	4998-00-0004	KLG	4998-00-0004	1
Q2 Q7	TRANS, SEL, 2N5462 QTY: 1: 4901-05-4620	4998-00-0008	KLG	4998-00-0008	2
Q8 9	TRANS, M/PR, 2N5485 QTY: 2: 4901-05-4850	4998-00-0009	KLG	4998-00-0009	1
IC4 IC5	OP AMP, LOW OFFSET/DRIFT JFET INPUT TIDNAL AMPLI	LF411CN	NSC	7000-04-1100	2
IC3	OP AMP, INTERNALLY COMP, HIGH	LM741CN	NSC	7000-07-4100	1

WAVETEK
PARTS LIST

TITLE
KIT, PRE WAVE LOAD 145-3245

ASSEMBLY NO. 1208-00-3246

PAGE 9

REV
A

REFERENCE DESIGNATORS	PART DESCRIPTION	DR10-MFGR-PART-NO	MFGR	WAVETEK NO.	QTY/PT
NONE	ASSY, SWITCH SW-1 145-0556	145-1565	WVTK	1202-00-1565	1
NONE	ASSY, SWITCH SW-2 145-0556	145-1566	WVTK	1202-00-1566	1
NONE	ASSY, SWITCH SW-3 145-0556	145-1567	WVTK	1202-00-1567	1
NONE	ASSY, SWITCH SW-4 145-0556	145-1568	WVTK	1202-00-1568	1
NONE	ASSY, SWITCH SW-5 145-0556	145-1569	WVTK	1202-00-1569	1

WAVETEK
PARTS LIST

TITLE
SUPER KIT

ASSEMBLY NO. 2500-0145-01

PAGE 1

REV

REFERENCE DESIGNATORS	PART DESCRIPTION	DR10-MFGR-PART-NO	MFGR	WAVETEK NO.	QTY/PT
Q35 Q48	PERFORMANCE TRANS, MONO, DUAL, NPN	LS312-52	LINSY	7000-08-1200	2
IC1 IC2 IC6	OP AMP, DUAL, HIGH GAIN, INTERNALLY COMP	MC1458P1	MDT	7000-14-5800	3
IC9	DIFFERENTIAL AMP, DUAL HIGH FREQ	CA3049T	RCA	7000-30-4900	1
IC7 IC8	OP AMP, BIPOLAR MOSFET INPUT/BIPOLAR OUTPUT	CA3140S	RCA	7000-31-4001	2

WAVETEK
PARTS LIST

TITLE
KIT, PRE WAVE LOAD 145-3245

ASSEMBLY NO. 1208-00-3246

PAGE 10

REV
A

REMOVE ALL BURRS AND BREAK SHARP EDGES	DRAWN	DATE	 WAVETEK SAN DIEGO • CALIFORNIA PARTS LIST PCA, GENERATOR
MATERIAL	CHECKED	PROJ. ENGR.	
FINISH WAVETEK PROCESS	RELEASE APPROV.	UNLESS OTHERWISE SPECIFIED DIMENSIONS ARE IN INCHES FRACTIONS DECIMALS ANGLES XX ± .XXX ±	
DO NOT SCALE DRAWING	SCALE	SHEET 3 OF 3	
TITLE		SIZE	DWG. NO.
D 23338		1100-00-3245	REV B
145-S-620		1	

NOTE: UNLESS OTHERWISE SPECIFIED

THIS DOCUMENT CONTAINS PROPRIETARY INFORMATION AND DESIGN RIGHTS BELONGING TO WAVETEK AND MAY NOT BE REPRODUCED FOR ANY REASON EXCEPT CALIBRATION, OPERATION, AND MAINTENANCE WITHOUT WRITTEN AUTHORIZATION.

REV	ECN	BY	DATE	APP
-----	-----	----	------	-----

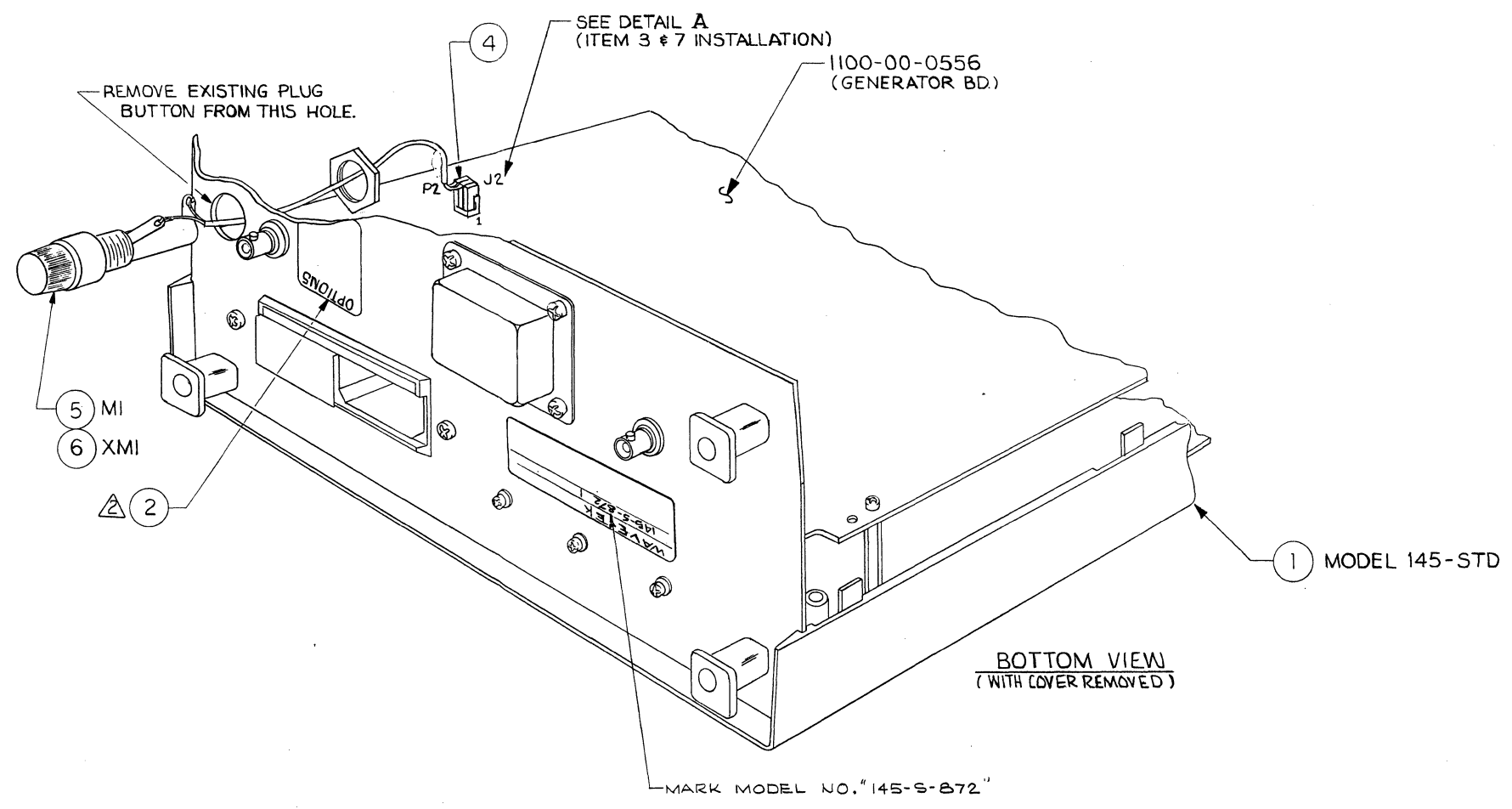
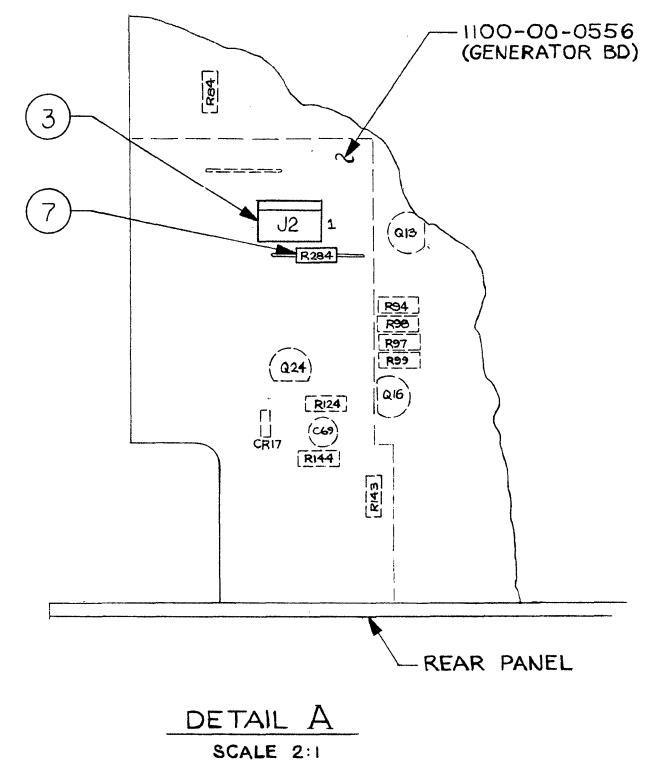
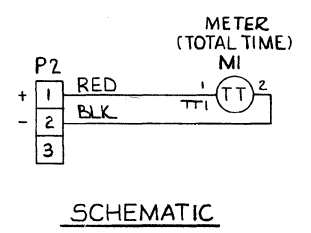
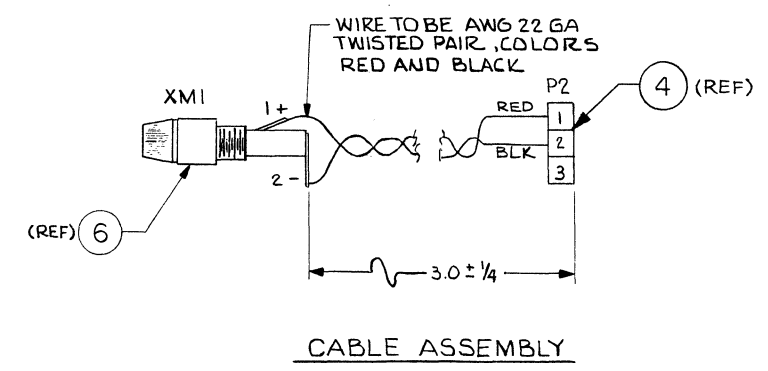

REFERENCE DESIGNATORS	PART DESCRIPTION	ORIG-MFGR-PART-NO	MFGR	WAVETEK NO.	QTY/PT
NONE	INSTALLATION DWG	0102-00-0221	WVTK	0102-00-0221	1
1	MODEL 145 20MHZ PULSE FUNCTIONGENERATOR	145-STD	WVTK	1000-00-0101	1
2	LABEL, OPTION	270-4960	WVTK	1400-01-4960	1
3	CONN HEADER 3 PIN	640456-3	AMP	2100-02-0116	1
4	HEADER, CONN 3 PIN	640440-3	AMP	2100-02-0117	1
5	INDICATOR, ELAPSED TIME (5000 HR)	T-000-4	FRED	2400-06-0006	1
6	HOLDER, TIMER	T-102	FRED	2400-06-0007	1
7	RES, MF, 1/8W, 1%, 2.15M	RN55D2154F	TRW	4701-03-2154	1

WAVETEK PARTS LIST

TITLE: MODEL 145-001 OPTION 5000 HOUR TIMER

ASSEMBLY NO.: 1000-00-0221

REV: PAGE 1

MARK LABEL FOR OPTION 001.

1. FOR PARTS LIST SEE 1000-00-0221

NOTE: UNLESS OTHERWISE SPECIFIED

REMOVE ALL BURRS AND BREAK SHARP EDGES	DRAWN S. MAGALUJA	DATE 7-5-5	WAVETEK SAN DIEGO • CALIFORNIA	
MATERIAL //	PROJ ENGR	RELEASE APPROV	TITLE MODEL 145-001 OPTION 5000 HOUR TIMER	
FINISH WAVETEK PROCESS //	TOLERANCE UNLESS OTHERWISE SPECIFIED XXX: 010 ANGLES: 1 XX: 030		MODEL NO. 145-001	DWG NO. 0102-00-0221
	DO NOT SCALE DWG	SCALE //	CODE IDENT 23338	REV
			SHEET (OF)	

REV	ECN	BY	DATE	APP
A	6153	A.T.	3/17/66	A.T.
B	770-	A.T.	7/11/66	A.T.

THIS DOCUMENT CONTAINS PROPRIETARY INFORMATION AND DESIGN RIGHTS BELONGING TO WAVETEK AND MAY NOT BE REPRODUCED FOR ANY REASON EXCEPT CALIBRATION, OPERATION, AND MAINTENANCE WITHOUT WRITTEN AUTHORIZATION.

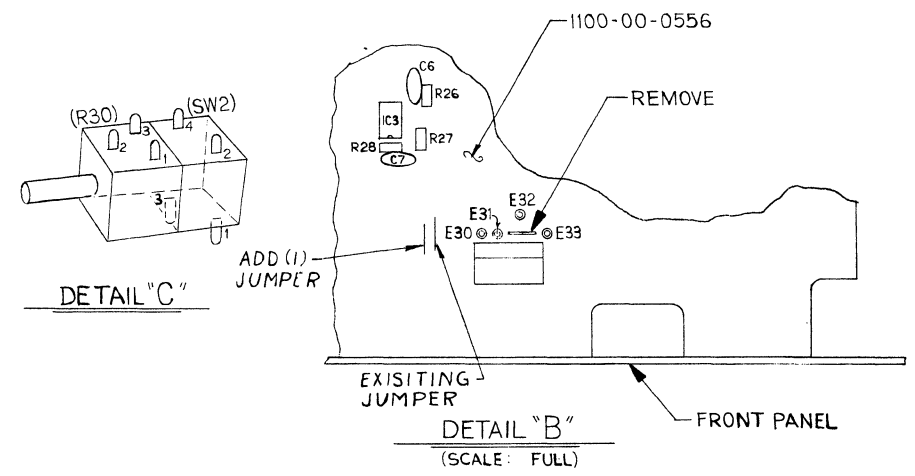
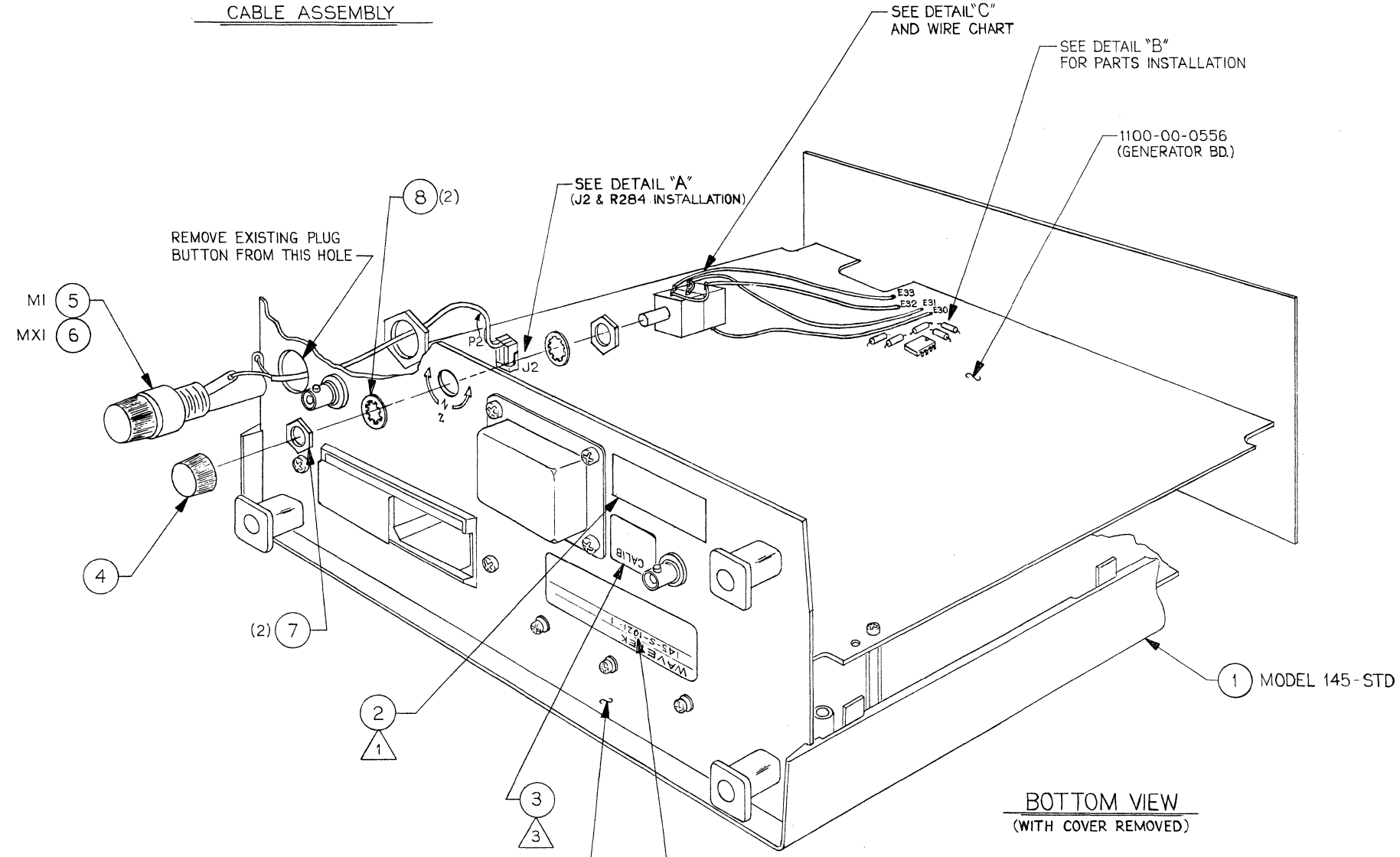
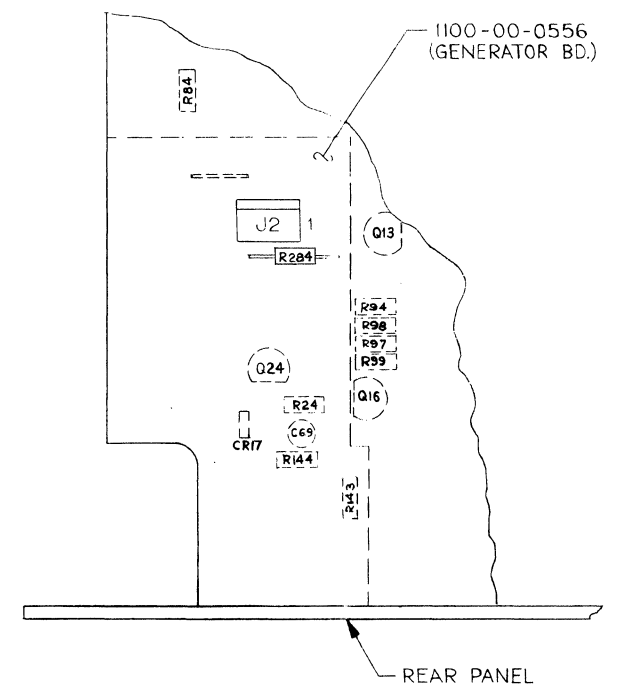
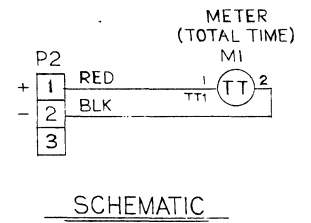
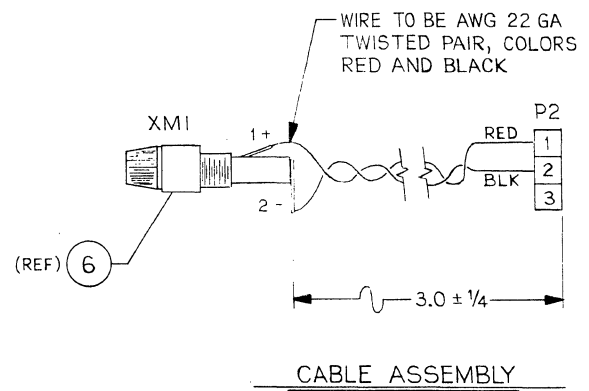

1. UPON COMPLETION OF CALIBRATION AND QUALITY CONTROL ACCEPTANCE APPLY SIGNED CALIBRATION LABEL IN AREA INDICATED.
2. REMOVE REAR PANEL 1400-00-6760 FROM FUNCTION GENERATOR 1000-00-0101 AND DRILL A .375 HOLE PER 1400-02-0603 AND SILKSCREEN REAR PANEL PER 1400-02-0600. REASSEMBLE REAR PANEL.
3. MARK LABEL FOR OPTION 003.
- NOTE: UNLESS OTHERWISE SPECIFIED

WIRE CHART			
FROM	TO	WIRE COLOR	LENGTH
R30-1	SW2-4	BARE	0.5
SW2-4	E31	RED	9.0
R30-2	SW2-2	ORN	1.0
SW2-2	E32	ORN	9.0
R30-3	SW2-3	YEL	1.5
SW2-3	E33	YEL	9.0
SW2-1	E30	BRN	9.0

SEE SEPARATE PARTS LIST 1000-00-0442

REMOVE ALL BURRS AND BREAK SHARP EDGES	DRAWN A. TALMADGE	DATE 3/17/66	
MATERIAL	PROJ ENGR D.E. FISH	DATE 3/17/66	
FINISH WAVETEK PROCESS	RELEASE APPROV	TOLERANCE UNLESS OTHERWISE SPECIFIED .XXX ± .010 ANGLES :1° XX ± .030	MODEL 145-003 OPTION 5000 HOUR TIMER & SYMMETRY CONTROL
SCALE NONE	DO NOT SCALE DWG	MODEL NO. 145-003 145-S-1021	DWG NO. 0102-00-0442
		CODE 23338	REV B

SHEET 1 OF 1

8

7

6

5

↓

4

3

2

1

REV ECN BY DATE APP

THIS DOCUMENT CONTAINS PROPRIETARY INFORMATION AND DESIGN RIGHTS BELONGING TO WAVETEK AND MAY NOT BE REPRODUCED FOR ANY REASON EXCEPT CALIBRATION, OPERATION, AND MAINTENANCE WITHOUT WRITTEN AUTHORIZATION.

D

D

REFERENCE DESIGNATORS	PART DESCRIPTION	ORIG-MFGR-PART-NO	MFGR	WAVETEK NO.	QTY/PT
NONE	SCHEMATIC, INSTRUMENT	0004-00-0101	WVTK	0004-00-0101	1
NONE	ASSY DRWG, MODEL 145 OPTION 5000 HOUR TIMER AND SYMMETRY CONTROL	0102-00-0442	WVTK	0102-00-0442	1
1	MODEL 145 20MHZ PULSE FUNCTIONGENERATOR	145	WVTK	1000-00-0101	1
NONE	ATP FOR MODEL 145 AND OPTIONS	1002-00-0101	WVTK	1002-00-0101	1
2	LABEL, OPTION, MODEL 23	1400-01-9890	WVTK	1400-01-9890	1
9	REAR PANEL	1400-02-0600		1400-02-0600	1
3	LABEL, WTK CALIB	1400-02-1460	WVTK	1400-02-1460	1
C6 C7	CAP CER MON .01MF 50V, AXIAL	CAC02Z5U103Z100A	CORNG	1500-01-0310	2
J2	CONN. HEADER, 3 PIN, .100 MTA	640456-3	AMP	2100-02-0116	1
P2	CONN. HEADER, 3 PIN	640440-3	AMP	2100-02-0117	1
4	KNOB STD	RB-67-1-SB-M	ROGAN	2400-01-0008	1
5	INDICATOR, ELAPSED TIME (5000 HR)	T-000-4	FRED	2400-06-0006	1

WAVETEK PARTS LIST TITLE MODEL 145 WITH SPECIAL OPTION S-1021 ASSEMBLY NO. 1000-00-0442 REV C
PAGE 1

C

C

REFERENCE DESIGNATORS	PART DESCRIPTION	ORIG-MFGR-PART-NO	MFGR	WAVETEK NO.	QTY/PT
6	HOLDER, TIMER	T-102	FRED	2400-06-0007	1
7	NUT, PANEL, 3/8X1/2X.09 2, Z	3/8 X 1/2 NUT	CHRCL	2800-16-0000	2
8	WASHER, INTERNAL TOOTH, 3/8 IN.	3/8ITLW	CHRCL	2800-28-0000	2
R30	CONTROL SHAFT, SWITCH-POT, CERMET, LINEAR 50K 10%, CCM DETENT	72LINO488503W	AB	4602-05-0304	1
R28	RES. MF, 1/8W, 1%, 2K	RN55D-2001F	TRW	4701-03-2001	1
R284	RES. MF, 1/8W, 1%, 2.15M	RN55D2154F	TRW	4701-03-2154	1
R26 R27	RES. MF, 1/8W, 1%, 4.99K	RN55D-4991F	TRW	4701-03-4991	2
IC3	OP AMP, INTERNALLY COMP. HIGH PERFORMANCE	LM741CN	NSC	7000-07-4100	1

WAVETEK PARTS LIST TITLE MODEL 145 WITH SPECIAL OPTION S-1021 ASSEMBLY NO. 1000-00-0442 REV C
PAGE 2

B

B

A

A

REMOVE ALL BURRS AND BREAK SHARP EDGES	DRAWN	DATE	WAVETEK SAN DIEGO • CALIFORNIA
MATERIAL	PROJENGR		
	RELEASE APPROV		TITLE PARTS LIST TIMER & SYMMETRY CONTROL
FINISH WAVETEK PROCESS	TOLERANCE UNLESS OTHERWISE SPECIFIED .XXX ±.010 ANGLES .1 XX ±.030		MODEL NO. 145-S-1021
	DO NOT SCALE DWG	SCALE	DWG NO. 1000-00-0442
			REV C
			CODE IDENT 23338 SHEET 1 OF 1

NOTE: UNLESS OTHERWISE SPECIFIED

8

7

6

5

↑

4

3

2

1