

WANG

III.B.4M-1

**CUSTOMER ENGINEERING REPRINT
FOR
TELEX 6253 MAGNETIC TAPE DRIVE
MAINTENANCE MANUAL**

JULY 1982

**REORDER NUMBER
729-1136**

Publication

Update

Bulletin

CUSTOMER SERVICE DOCUMENTATION

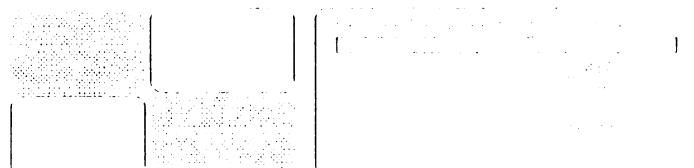

Date: 08/08/88 **Color:** Orange

Title: VS AB Tape Switch - Telex Drive Configuration

This PUB Affects: 729-1136
742-1136

Previous Notices: None

Reason For Change: This PUB adds Appendix C to the Telex Tape Drive Maintenance Manual which describes the VS AB Tape Switch as it is used in the Telex Tape Drive Model 2219V Configuration.

COMPANY PROPRIETARY STATEMENT

This document is the property of Wang Laboratories, Inc. All information contained herein is considered Company Proprietary, and its use is restricted solely to assisting you in servicing Wang products. Neither this document nor its contents may be disclosed, copied, revealed, or used in whole or in part for any other purpose without the prior written permission of Wang Laboratories, Inc. This document must be returned upon request of Wang Laboratories, Inc.

WANG

729-1136-1

COMPANY CONFIDENTIAL

Instructions: Remove and insert attached microfiche and/or pages as follows:

Remove Fiche:

1, 3, 4, &5

Insert Fiche:

1, 3, 4, 5, &6

Remove Page:

v

Insert Page:

v, Appendix C title
page, and pages C-1
thru C-11

This sheet constitutes a permanent record of revisions: place it directly following the title page and in front of any previous PUB cover sheets.



LIST OF EFFECTIVE PAGES

The total number of pages in this manual is 274

Page No.

i	to	vii
1-1	to	1-4
2-1	to	2-12
3-1	to	3-5
4-1	to	4-33
5-1	to	5-31
6-1	to	6-99
7-1	to	63 schematics
A-1	to	A17
B-1	to	B-2

RECORD OF REVISIONS

REVISION LEVEL	DATE	DESCRIPTION	CLC LEVEL
-------------------	------	-------------	--------------

MARCH 1980

Original Release

JUNE 1980

Reprint with corrections

CONTENTS

Paragraph Page

SECTION 1 GENERAL CHARACTERISTICS

1.1	Physical Description	1-1
1.2	Functional Description	1-1
1.3	Performance Characteristics	1-3
1.4	Optional Features	1-4

SECTION 2 INSTALLATION

2.1	General	2-1
2.2	Physical and Environmental Requirements	2-1
2.3	Pre-Installation Requirements	2-1
2.4	Equipment Rack	2-4
2.4.1	Physical Strength	2-4
2.4.2	Stability	2-4
2.5	External Cable Installation	2-4
2.6	Unpacking	2-5
2.7	Installation Procedures	2-5
2.7.1	Standard Telex Cabinet-Mount	2-5
2.7.2	Rack-Mount	2-9
2.8	I/O Interface Connection	2-10
2.9	AC Power Connection	2-12
2.10	Installation Checkout	2-12

SECTION 3 OPERATION

3.1	Tape Markers	3-1
3.2	File Protection	3-2
3.3	Operator Control Panel	3-2
3.4	Off-Line Operation	3-3
3.4.1	Loading Tape	3-3
3.4.2	Load Following Load Check	3-3
3.4.3	Rewinding Tape	3-4
3.4.4	Unloading Tape	3-4
3.4.5	Transfer from On-Line to Off-Line Status	3-4
3.5	On-Line Operation	3-4
3.5.1	Density Control	3-4
3.5.2	On-Line Control	3-4
3.6	Operator Maintenance	3-5
3.6.1	Cleaning the Tape Path	3-5
3.6.2	Lamp Replacement	3-5

SECTION 4 PRINCIPLES OF OPERATION

4.1	General	4-1
4.2	Power Supply	4-1
4.2.1	General	4-1
4.2.2	AC Power Control	4-2
4.2.3	Regulated Power Supply	4-2
4.2.4	Unregulated Power Supply	4-3
4.3	Pneumatic System	4-3
4.3.1	Pneumatic Supply	4-3
4.3.2	Diverter Valve	4-3
4.3.3	Cartridge Valve	4-3
4.3.4	Metering Valves	4-4
4.3.5	Differential Switches	4-4
4.4	Tape Deck	4-4
4.5	Capstan Drive System	4-4
4.6	Reel Drive System	4-7
4.6.1	Reel Motor and Drive Amplifiers	4-7
4.6.2	Analog Switching	4-8
4.6.3	Motor Torque	4-8
4.6.4	Vacuum Column Sensors	4-9
4.6.5	Reel Tachometer	4-9
4.6.6	Servo Logic	4-9
4.6.7	Vacuum Bias	4-9
4.6.8	Power Loss Relay	4-9
4.7	Control Logic	4-11
4.7.1	Autoload	4-11
4.7.2	Autoload Timing	4-17
4.7.3	Rewind or Unload	4-21
4.7.4	Tester	4-22
4.8	Telex Interface 92D72203	4-23
4.8.1	Commands	4-23
4.8.2	Status Reporting	4-25
4.8.3	Data Transfer	4-26
4.8.4	Tape Drive Inputs from Formatter	4-26
4.8.5	Tape Drive Outputs to Formatter	4-26
4.9	Data Electronics	4-27
4.9.1	NRZI/PE/GCR Write	4-27
4.9.2	PE/GCR Read	4-29
4.9.3	NRZI Read	4-31
4.10	Manual Density Selection and Forced Read	4-32
4.10.1	Computer Adapter Interface	4-32
4.10.2	Tape Unit Interface	4-32
4.10.3	Tape Unit Operator Control Panel	4-32
4.10.4	Subsystem Write Operations	4-33
4.10.5	Subsystem Read Operations	4-33

SECTION 5 MAINTENANCE

5.1	Preventive Maintenance	5-1
5.1.1	Daily Maintenance	5-1
5.1.2	Quarterly Maintenance	5-2
5.1.3	Semi-Annual Maintenance	5-2
5.1.4	Annual Maintenance	5-2
5.2	Service Checks and Adjustments	5-3
5.2.1	Power Supply Adjustment	5-3
5.2.2	Pack Sense Adjustment	5-6
5.2.3	BOT-EOT Adjustment	5-6
5.2.4	Reel Preamp Adjustment	5-6
5.2.5	Capstan Preamp Adjustment	5-7
5.2.6	Head Azimuth Adjustment	5-10
5.2.7	NRZI Read Skew Adjustment	5-11
5.2.8	Write Current Adjustment	5-12
5.2.9	Read Level Adjustment	5-13
5.2.10	Capstan Mechanical Alignment	5-13
5.2.11	Head Removal and Replacement	5-16
5.2.12	Tape Cleaner Adjustment	5-17
5.2.13	Crosstalk Shield Adjustments	5-19
5.2.14	BOT-EOT Mechanical Alignment	5-19
5.2.15	Reel Tachometer Mechanical Alignment	5-22
5.2.16	Belt Tension Adjustment	5-22
5.2.17	Pneumatic Adjustments	5-23
5.3	Tester Operation	5-29
5.3.1	Tape Motion Commands	5-29
5.3.2	Write Data	5-29
5.4	Reel Adjustments	5-30
5.4.1	File Reel Latch	5-30
5.4.2	Fixed Reel Installation and Alignment	5-30

SECTION 6 PARTS LIST

6.1	General	6-1
6.2	Numbering System	6-1
6.2.1	Drawing Number	6-1
6.2.2	Part and Assembly Number	6-2
6.2.3	Part Number for Purchased Part	6-2
6.3	6253 Assemblies	6-3

SECTION 7 LOGIC and SCHEMATIC DRAWINGS

7.1	Index of Logic and Schematic Drawings	7-1
-----	---------------------------------------	-----

APPENDIX

A	Signal Index	A-1
B	Power Supply	B-1
C	VS AB Tape Switch - Telex Configuration	C-1

ILLUSTRATIONS

Figure		Page
1-1	Telex 6253 Series Tape Drive in OEM Cabinet	--
1-2	Telex 6253 Series Tape Drive	1-2
2-1	Installation Specification	2-2
2-2	Rack Stability Diagram	2-6
2-3	Tape Drive in Packing Crate	2-7
2-4	Tape Drive Removal From Shipping Rack	2-8
2-5	Telex I/O Interface Cable Assembly	2-11
3-1	ANSI Standard Tape Markers	3-1
3-2	Operator Control Panel	3-2
4-1	Power Supply Panel	4-2
4-2	Tape Deck Components, Front	4-5
4-3	Tape Deck Components, Rear	4-6
4-4	Capstan Servo Simplified Circuit	4-7
4-5	Reel Servo Simplified Circuit (File reel)	4-8
4-6	Vacuum Column Sensor Control of Reel Motors	4-10
4-7	Load Sequencer Flow Chart	4-11
4-8	Load Sequencer Simplified Logic	4-12
4-9	Autoload Flow Chart	4-13
4-10	Autoload Timing Charts	4-17
4-11	Rewind or Unload Flow Chart	4-21
4-12	Telex Interface Commands	4-23
4-13	Command Decoding Flow Chart	4-24
4-14	Sense Bytes	4-25
4-15	6253 Write Electronics Simplified Logic	4-28
4-16	PE/NRZI Read Simplified Logic	4-30
4-17	6253 NRZI Read Simplified Logic	4-31
5-1	Power Supply Voltage Adjustments	5-4
5-2	Power Supply Internal Fuse Location	5-5
5-3	File Reel Hub with Timing Mark	5-5
5-4	Head Azimuth Adjustment	5-11
5-5	Capstan Mechanical Adjustment	5-15
5-6	Head Mounting Detail	5-17
5-7	Tape Cleaner Alignment Gauge	5-18
5-8	Tape Cleaner Alignment	5-18
5-9	Crosstalk Shield Assembly	5-20
5-10	BOT-EOT Assembly Mechanical Alignment	5-21
5-11	Reel Tachometer Mechanical Alignment	5-21
5-12	Belt Tensiometer	5-23
5-13	Vane Adjustment	5-24
5-14	Pneumatic Components, Front	5-26
5-15	Pneumatic Components, Rear	5-27
5-16	Card Cage and PCB	5-28
5-17	Collet Alignment Detail	5-31

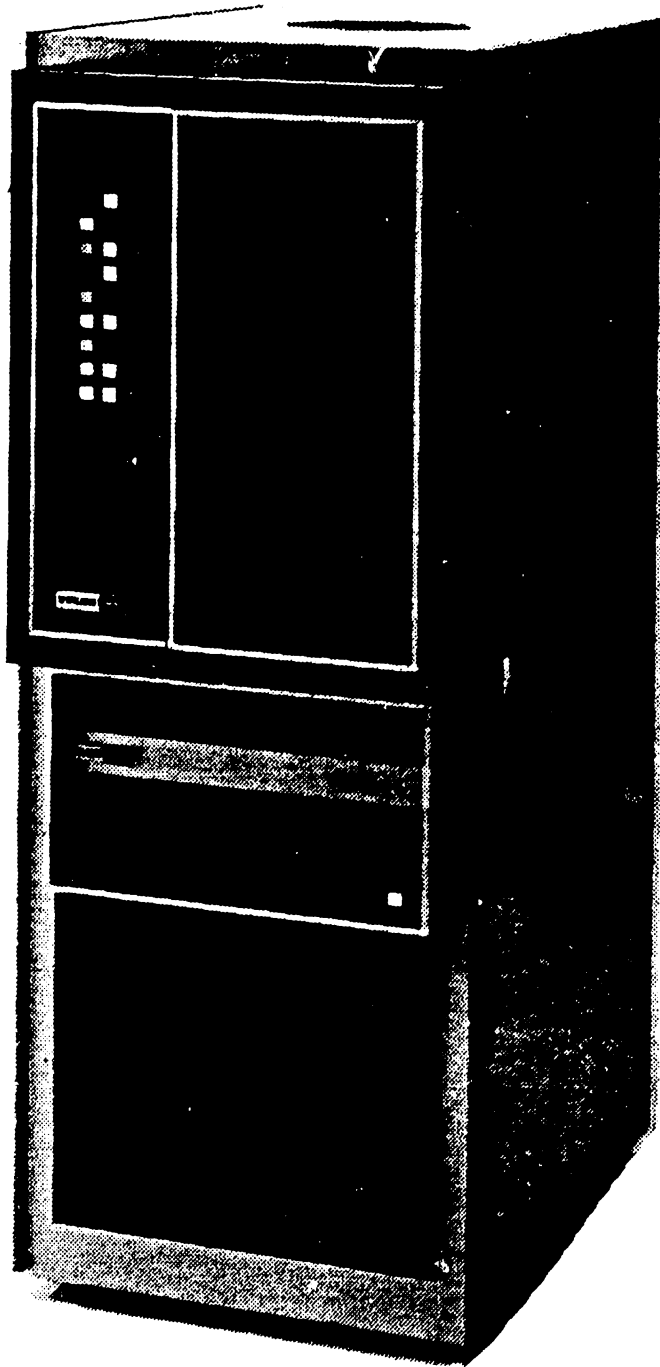

Figure 1-1. Telex 6253 Series Tape Drive in OEM Cabinet

SECTION

1

GENERAL

CHARACTERISTICS

SECTION 1

GENERAL DESCRIPTION AND CHARACTERISTICS

1.1 PHYSICAL DESCRIPTION

The Telex 6253 Series tape drive provides for selection of three formats, NRZI, PE, or GCR. It features maximum versatility and a unique design concept which reflects state-of-the-art technology throughout, such as the Supr-Lite™ minimal-mass capstan and the maximum-efficiency, canted vacuum columns.

The 6253 is designed to fit into a standard RETMA 19-inch rack and is 24.5 inches high, 19 inches wide, and 22.5 inches deep. The unit extends 4.15 inches in front of the rack mounting surface and requires no rack filler panels. The approximate weight is 300 pounds.

When mounted in the standard Telex cabinet the drive stands 60 inches high, is 24 inches wide and 31 inches deep, and weighs approximately 400 pounds.

With the exception of large power supply components all electronics are on plug-in assemblies accessible from the front of the unit.

The operator control panel is located on a hinged covering over the tape path to the left of the tape reels.

The AC power cable is installed at the rear of the unit in the power supply module. Interface cables are attached to mating connectors on the tape transport. Input/Output (I/O) electronics are on printed circuit boards.

1.2 FUNCTIONAL DESCRIPTION

The 6253 is a high-performance, computer compatible tape drive capable of transporting 0.5 inch magnetic tape over a speed range of 50 to 125 inches per second using a single capstan, direct drive system.

The unit consists of the tape drive mechanism with its associated read, write, servo, and control electronics, plus the necessary power supplies.

The unit operates at densities of 800 bpi NRZI, 1600 bpi PE or 6250 bpi GCR format in standard 9-track configuration. It automatically loads standard 10.5 inch tape reels as well as all tape reels of lesser diameter with operator assistance.

Autoload also functions with Easy Load I* and Easy Load II* cartridges. No configuration changes are necessary in the tape drive.

The patented tape path and patented Supr-Lite capstan employed by the tape drive give it the capability of starting and stopping within the requirements of both 0.6 and 0.3 inch interblock gaps in either reading or writing mode.

*TM IBM

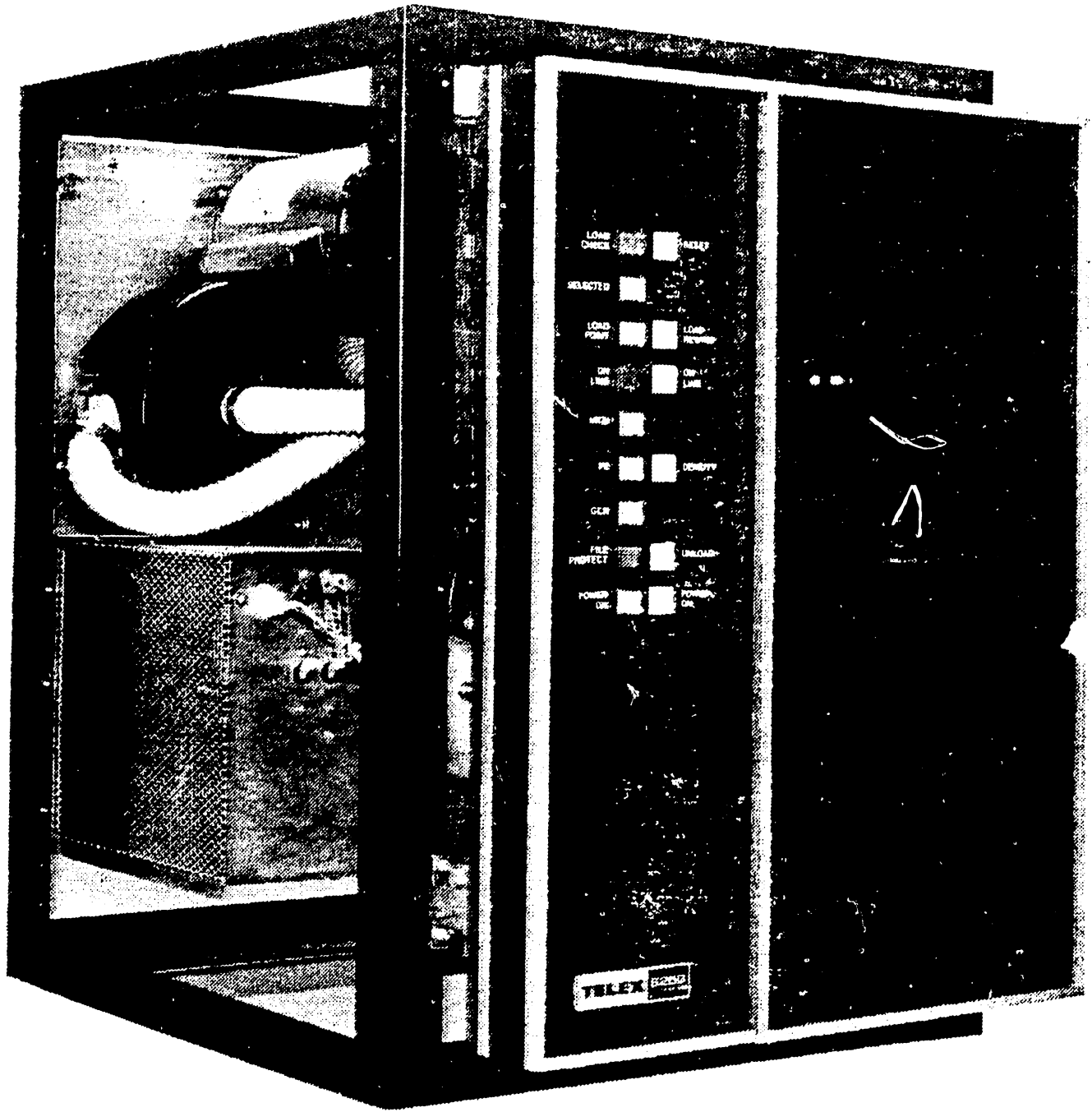

Figure 1-2. Telex 6253 Series Tape Drive

1.3 PERFORMANCE CHARACTERISTICS

The following table details the performance characteristics of the four versions of the 6253. All parameters are predicated upon the use of new, certified tape on a properly aligned and maintained tape drive.

Characteristics of 6253 Tape Drive

Performance	6253		
Tape Speed (ips)	6253-33	50 ips	
	6253-44	75 ips	
	6253-66	125 ips	
	6253-19	75 ips GCR/ 125 ips PE and NRZI	
Density (bpi)	800/1600/6250		
Recording Format	NRZI/PE/GCR		
Number of Tracks	9		
Data Transfer Rate (kb/sec)	40-100 NRZI 80-200 PE 312.5-781 GCR		
Interblock Gap (in)	0.6 PE and NRZI/0.3 GCR		
Start/Stop Time (ms)	50 ips	3.0(+or-)0.3 GCR	8.5(+or-)0.8 NRZI or PE
	75 ips	1.7(+or-)0.2 GCR	5.0(+or-)0.5 NRZI or PE
	125 ips	1.1(+or-)0.1 GCR	3.0(+or-)0.3 NRZI or PE
Start/Stop Distance (in)	0.065 (+or-) 0.016 GCR 0.190 (+or-)0.020 NRZI or PE		
Rewind Time, 2400 ft reel (sec)	60(+or-)10%		
Rewind Speed (ips)	500		
Environmental			
Operating Temperature	40-100° F (5-43°C.)		
Relative Humidity	30-80% (non-condensing)		
Operating Altitude (ft)	0-3500 (3500-7000 optional)		
Physical			
Mounting	19" EIA Rack		
Weight	300 lbs		
Height	24.5		
Width (in)	19		
Depth (in)	22.5		

Electrical

Interface	Telex Standard or OEM Industry compatible
Power	115 or 230 VAC, 50 Hz or 60 Hz
Power Consumption (watts)	Ready/On line, tape loaded- 1000 Operating with tape motion- 1440

1.4 OPTIONAL FEATURES

The following optional features currently available may be incorporated at the factory or in the field.

Option

Part Number	Name
95A20451	Unbiased Hinge Option
95A20455	High Altitude Option
95C20466	Shadow Box Assembly Option
95D20487	OEM Frame Assy.
95A20490	Power Frequency Conversion
94A20184	Voltage Conversion Kit

SECTION 2

INSTALLATION

SECTION 2

INSTALLATION

2.1 GENERAL

This section provides information for unpacking, installation, interfacing, and initial checkout of the Telex 6253 Series tape drive. It is applicable in both rack-mount and cabinet configurations.

2.2 PHYSICAL AND ENVIRONMENTAL REQUIREMENTS

Prior to adding the tape unit to a system, consideration must also be given to service access clearance in determining installation area requirements. Service boundary requirements are detailed in Figure 2-1.

The 6253 tape drive is designed to function optimally in a clean, air-conditioned computer room environment. However, OEM rack-mount versions may be used in light duty mobile applications, provided that the temperature, humidity and altitude specifications are observed.

2.3 PRE-INSTALLATION REQUIREMENTS

Before installation is begun, compliance with the following physical requirements of the facility should be verified;

1. Space and layout requirements
2. Air-conditioning system operation
3. Machine component layout
4. Floor construction
5. System power requirements
6. Safety and fire precautions

The following safety precautions should be observed during the installation;

1. At least two men should always be present whenever work is being done with power on the unit.
2. Use extreme caution when working near live power connectors, convenience outlets, or inside power supplies. Turn off power before removing any units or components. Be aware that in some areas potentially dangerous voltages remain even after the power is off.
3. Be certain that all test equipment is grounded.
4. Keep the machine room neat and clean. This will aid in preventing fire and accidents.

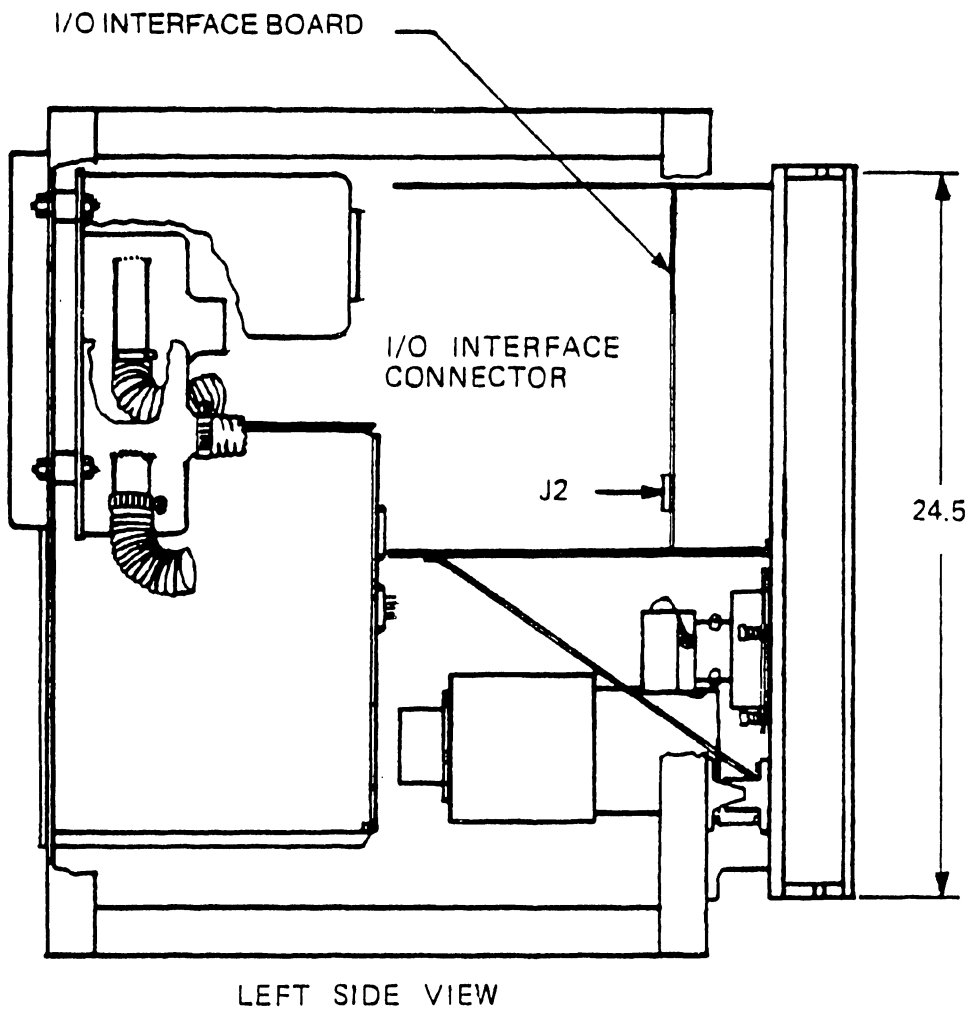
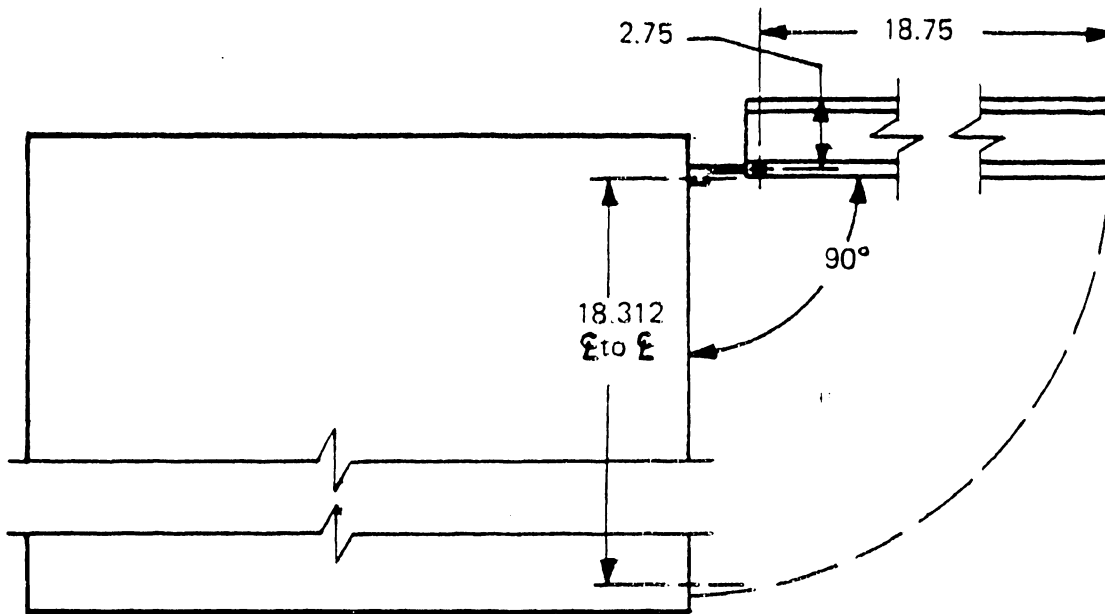

Figure 2-1. Installation Specification

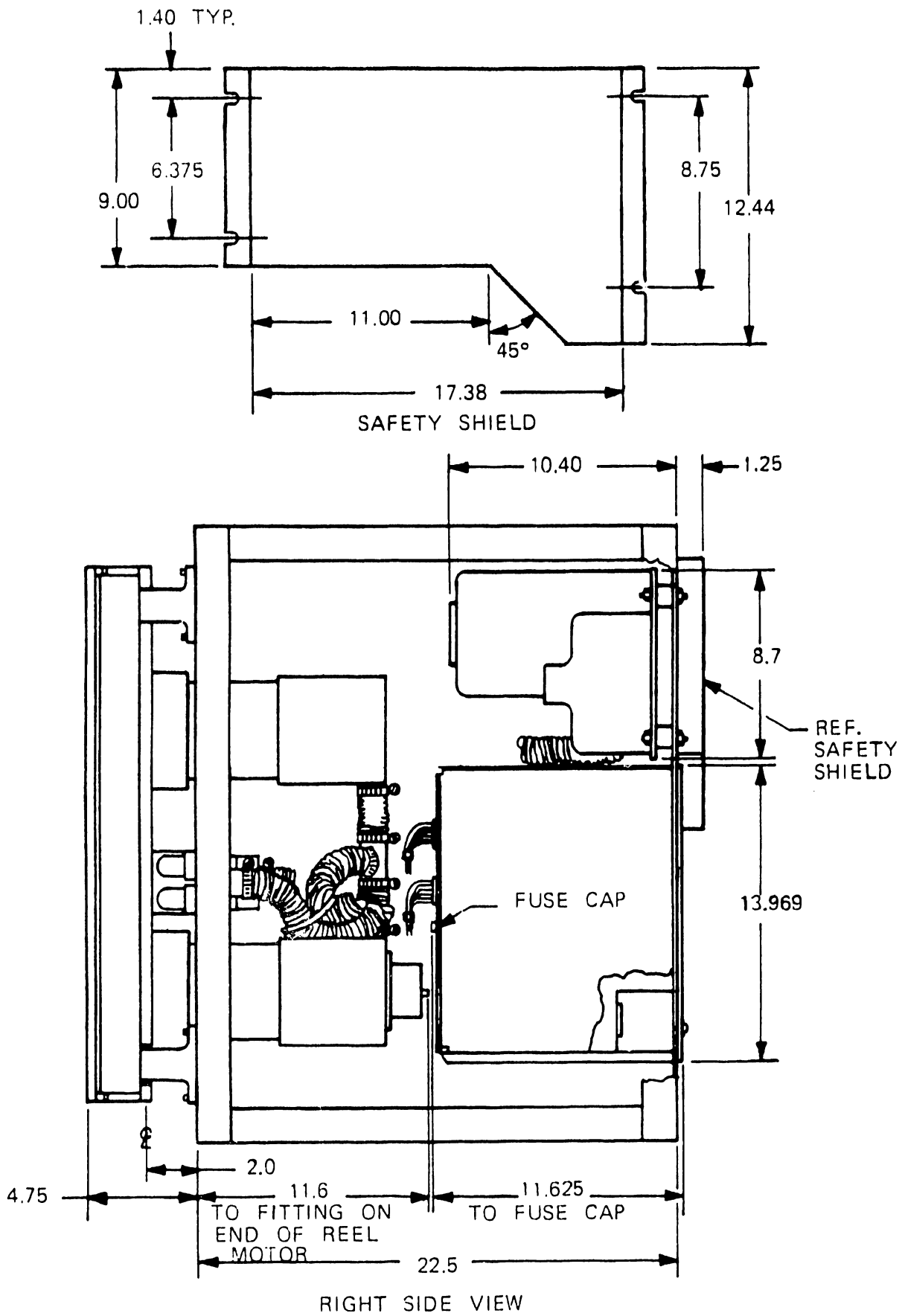

Figure 2-1. Installation Specification (Continued)

2.4 EQUIPMENT RACK

The tape drive depth dimension is 22.5 inches. Refer to Figure 2-2. This dimension can be increased. However if greater than 23 inches, the new dimension should be specified in order that the proper length hoses and cables can be supplied.

The vertical trim and corner mullions should not exceed the dimensions shown in Figure 2-2. The one and a half inch width is required on each side when the racks are to be ganged together. When the right side of the rack is against a wall or similar surface this dimension shall be three inches.

2.4.1 Physical Strength

The mounting surfaces of the cabinet or rack should be constructed from 12 gauge (0.1046 inch thick) cold rolled steel, CRS, or greater formed angles. All mounting holes are to be drilled and tapped to accept 10-32 NF-2B. Clearance holes and captive nuts are not recommended.

The formed angles should be secured to the structure of the rack within five inches of the hinge attachment points. The structure should be a rigid, all welded unit, with the corners braced to resist distortion when the tape deck is opened. A stiffener is provided to increase the torsional rigidity of the mounting surface.

2.4.2 Stability

The weight of the rack times the horizontal distance in inches between the center of gravity of the rack and the line of contact of the front supports, X, with the supporting surface shall be greater than:

$$2700 + 200E,$$

where E is the distance in inches between the mounting surface and the contact line. Refer to Figure 2-2 for further details.

2.5 EXTERNAL CABLE INSTALLATION

External interconnecting cables should be installed under a raised floor. They should be kept as short as possible not to exceed 20 feet in length. The required length is the distance between machine connectors measured along the intended route of the cable on the floor or other mounting surface. In installations with a raised floor, twice the floor height should be included in the cable length. Where there is no raised floor, cables should be protected from damage and scuffing, and arranged in a way that will not present a safety hazard to operating personnel.

External cables to be placed beneath a raised floor should be installed before the system components arrive in the computer area. Cables to be installed above the floor are placed on the floor last, after all tape units have been positioned.

When replacing an existing tape unit with a Telex 6253 unit, use the existing floor opening when possible. If it should prove necessary to remove panels to facilitate cable routing from the transport to the formatter, replace the panels immediately after cable installation is completed.

In a new installation check all floor openings for proper location and correct size before installing cables. A system floor plan should be available to show correct floor layout with floor openings marked to show machine location.

After completion of cable routing, connectors should be kept as much below floor level as possible until the units are in position. All connector coverings are to be kept on until the connections are made.

2.6 UNPACKING Ref. Figure 2-3

1. Inspect packing crate for evidence of mishandling.
2. Inspect unit for damage.
3. Be sure operator control panel is up.
4. Cut band and bag.

2.7 INSTALLATION PROCEDURES

CAUTION

Do not apply AC power to the unit until all aspects of the installation are complete. Refer to Paragraph 2.9 before making the power connection.

2.7.1 Standard Telex Cabinet-Mount

1. If the unit is to be installed on a raised floor, there should be an access opening in the floor to accommodate the cables.
2. Roll the unit on its casters to the installation position.
3. Turn each leveling pad counterclockwise until the cabinet is raised off its casters to the desired height.

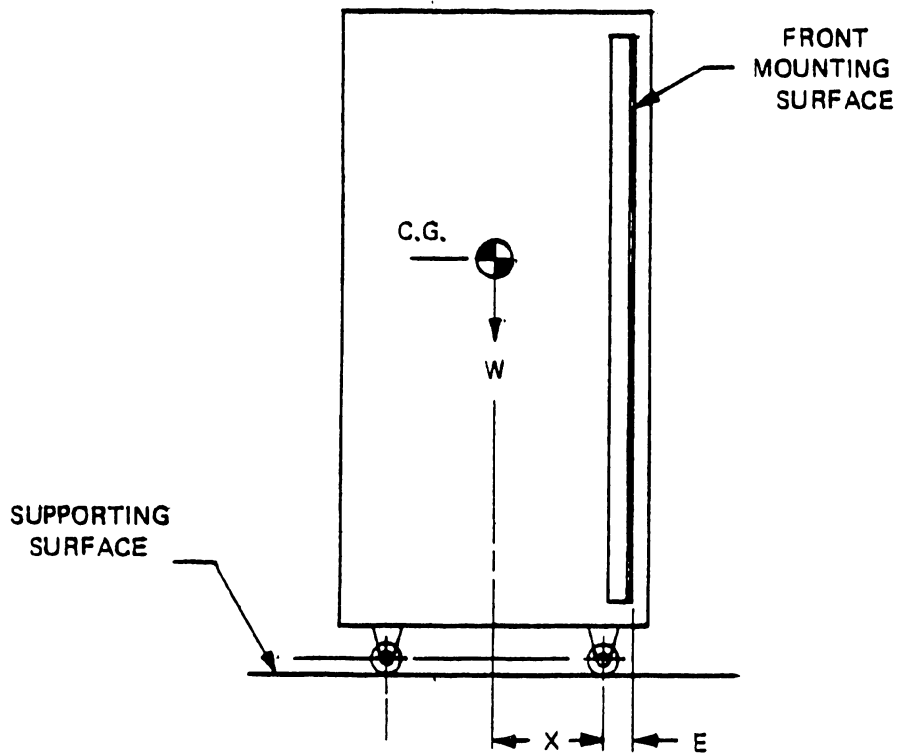
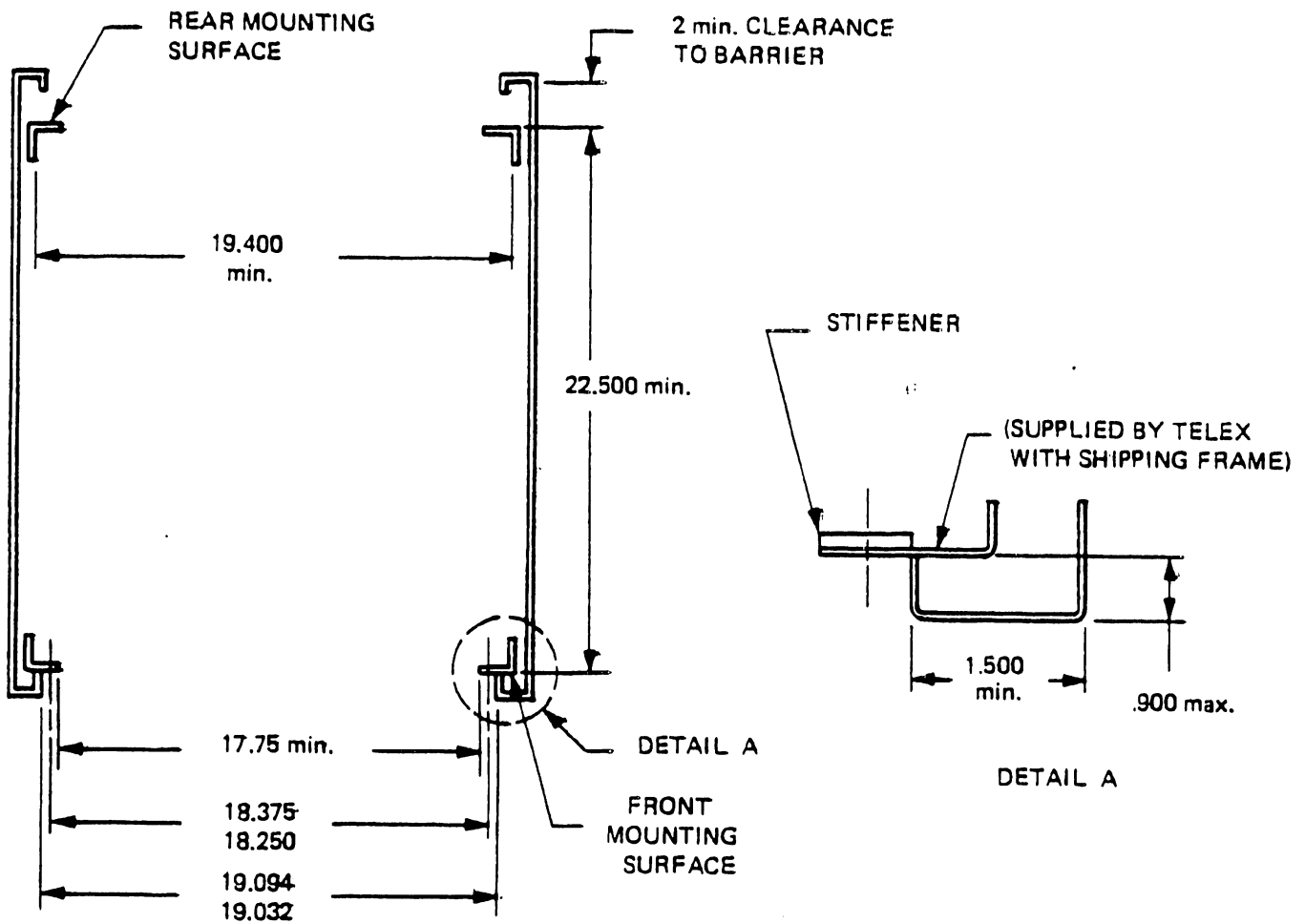

Figure 2-2. Rack Stability Diagram

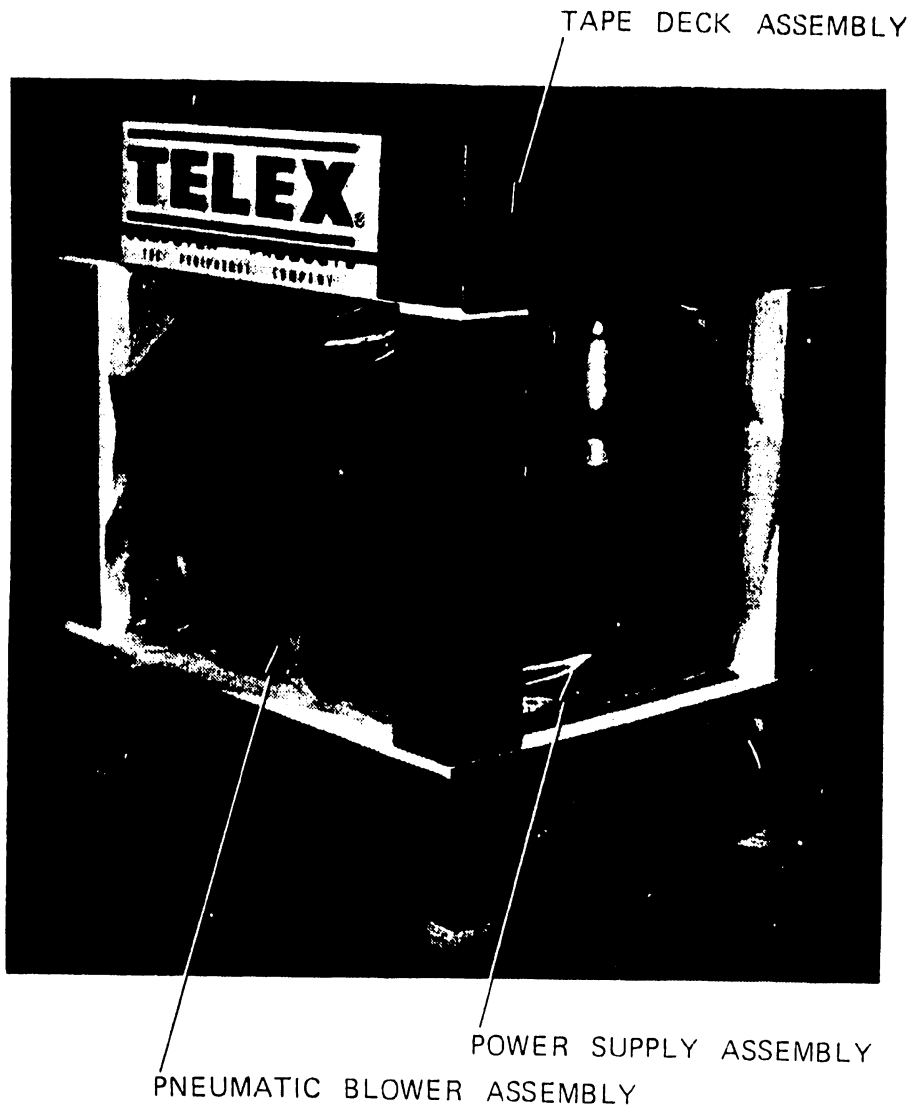

Figure 2-3. Tape Drive in Packing Crate

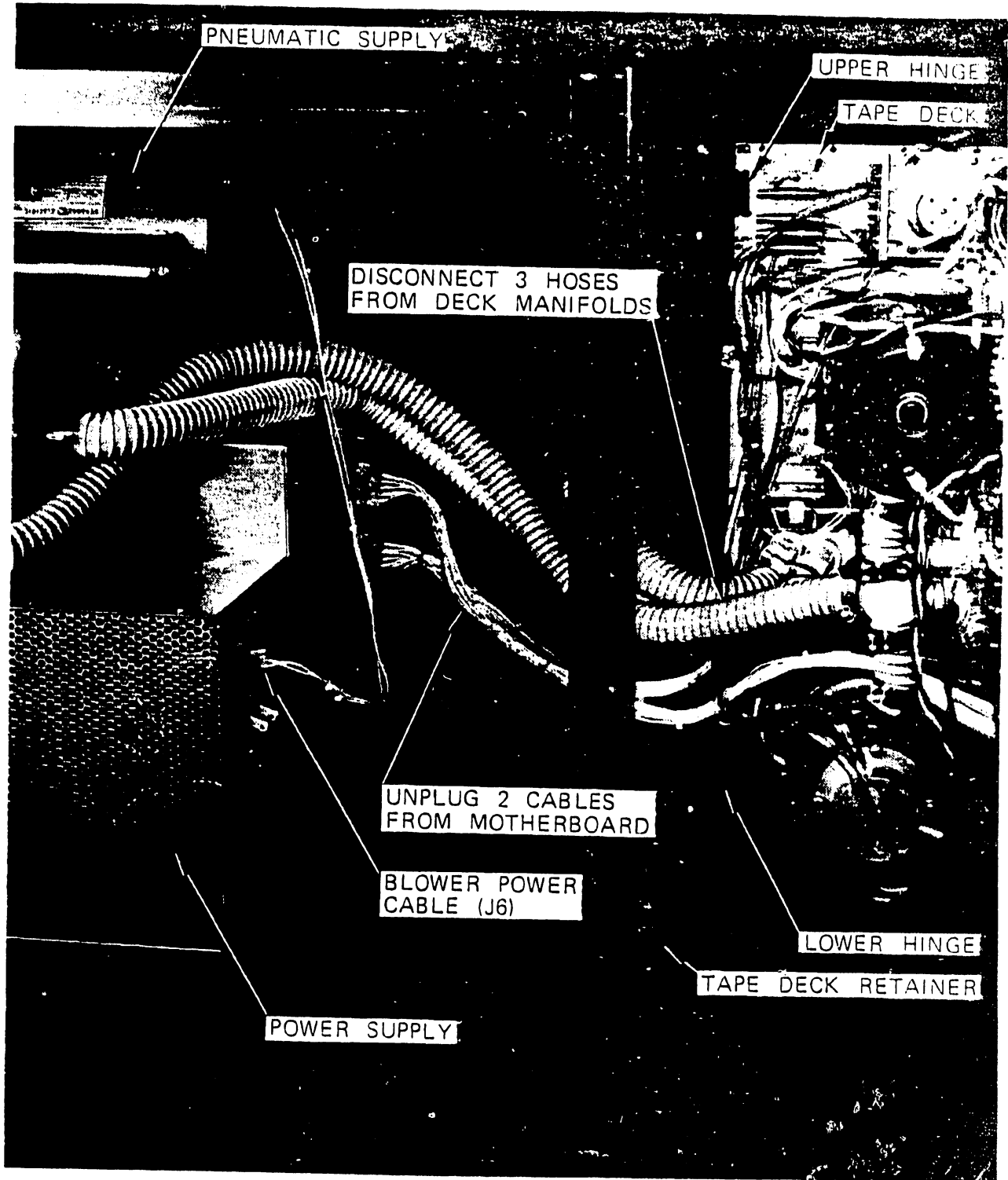

Figure 2-4. Tape Drive Removal From Shipping Rack

2.7.2 Rack-Mount Ref. Figure 2-4

1. Lay the empty user rack on its back.
2. Place the tape unit, still mounted in its shipping rack, on a stable work surface.
3. Open window to the right.
4. Pull out the vacuum column cover release latches and open the cover to the left.
5. Insert a Phillips screwdriver into the deck release screw access hole located in the lower left edge of the tape deck front.
6. Open the deck.
7. Unplug the two harness connectors from receptacles J16 and J17 on the card cage motherboard.
8. Disconnect the pressure and vacuum hoses from the manifolds on the rear of the tape deck.
9. Remove the tape deck retainer bracket from the shipping rack and transfer it to the left rail of the user rack.
10. Unscrew both deck hinges from the frame.
11. Remove the tape deck from the shipping rack and carefully install it inside the rack.
12. Disconnect the blower power cable from connector J6 on the power supply assembly.
13. Raise rack to vertical position.
14. Remove the belt cover plate, blower assembly, and power supply assembly from the shipping rack.
15. Unscrew the shock mounts and install them in the rack.
16. Reassemble the blower assembly, belt cover plate and power supply assembly on the back rails of the user equipment rack.
17. Reconnect the blower power cable to connector J6 on the power supply assembly.
18. Reconnect the power supply and tape deck cable to J16 and J17 on the motherboard. Route the cables over the reel motor.
19. Reconnect the vacuum and pressure hoses from the blower assembly to the manifold inlets on the rear of the tape deck.
20. Close the tape deck and turn the deck retainer screw clockwise to lock it in position. Should the deck retainer screw fail to engage the socket in the deck retainer bracket, a slight realignment of the bracket may be required.

2.8 I/O INTERFACE CONNECTION

1. Telex I/O Interface Signals

Signals to and from the unit are routed via a 50-pin connector mounted on the I/O board.

The table below lists the individual pin assignments.

2. Interface Cable

The interface cable is supplied by the user and is attached to the unit at connector J2 of the I/O board located in card slot 7. Figure 2-5 provides the necessary part numbers and dimensions for the cable.

Telex I/O Connector and Pin Assignments

Signal	J2 Pin No.	J2 Ground
TAG OUT	26	1
THLD OUT	27	2
OP OUT	28	3
BUS OUT P	29	4
BUS OUT 0	30	5
BUS OUT 1	31	6
BUS OUT 2	32	7
BUS OUT 3	33	8
BUS OUT 4	34	9
BUS OUT 5	35	10
BUS OUT 6	36	11
BUS OUT 7	37	12
STATA	38	13
BUS IN P	39	14
BUS IN 0	40	15
BUS IN 1	41	16
BUS IN 2	42	17
BUS IN 3	43	18
BUS IN 4	44	19
BUS IN 5	45	20
BUS IN 6	46	21
BUS IN 7	47	22
TRWNR	48	23
TAG IN	49	24
TACH IN	50	25

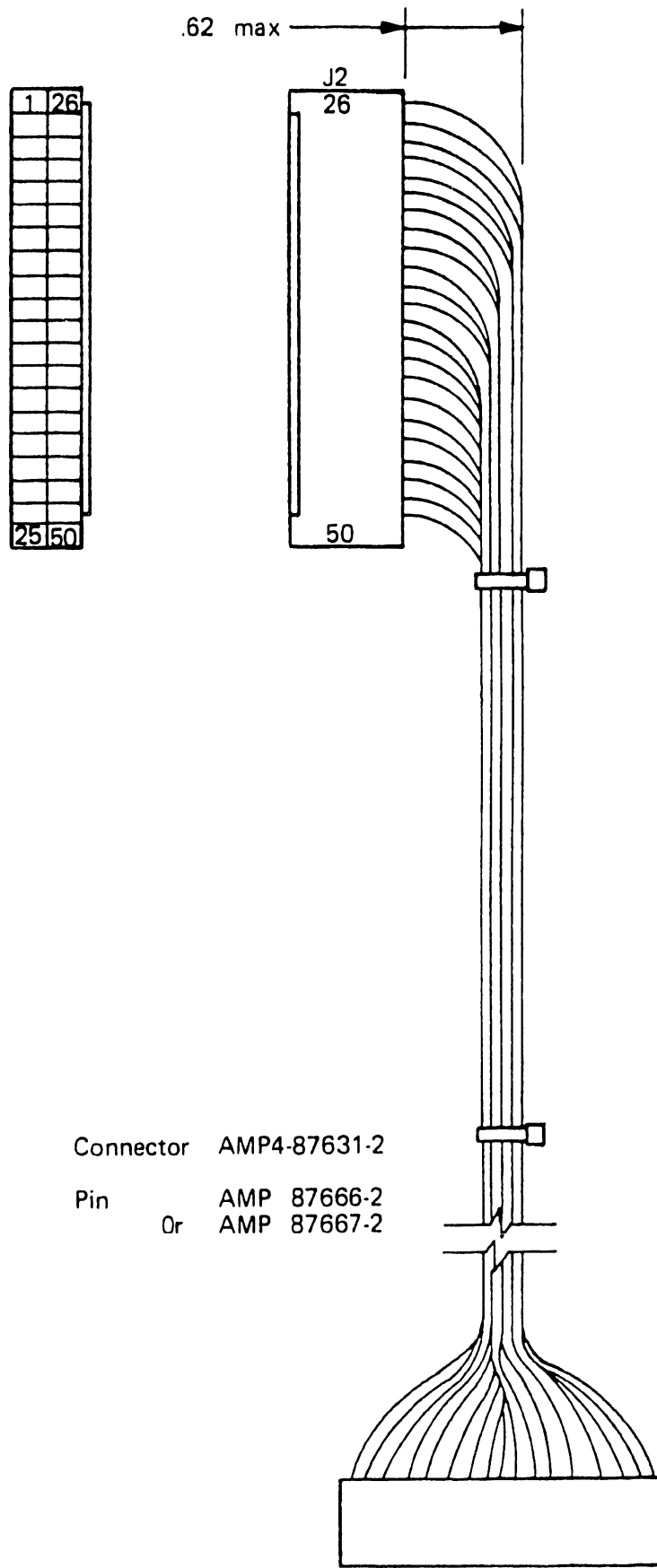

Connector AMP4-87631-2

Pin AMP 87666-2
Or AMP 87667-2

Figure 2-5. Telex I/O Interface Cable Assembly

2.9 AC POWER CONNECTION

The power cable for the tape unit may be constructed from the 3-wire twist-lock power connector in the shipping kit: Hubbell 2313 (125V 20A) or 2323 (250 V 20A). For connecting the tape unit to the site power receptacle, use a 14-gauge S3 or So-3 type 3-wire conductor equipped with a grounding plug. Conform to the following color code and pin assignments.

black-----hot line
white-----neutral
green-----power ground

The power input receptacle for the unit is recessed into the rear panel of the power supply assembly.

The voltage requirement for each unit is stamped on the equipment nameplate. The power transformer taps are set at the factory to the voltage specified on the equipment order. Before applying power to the unit, make certain that this voltage figure matches the voltage in use at the installation site.

NOTE

The AC power source should be protected by a 20 ampere slow tripping (motor starting curve) circuit breaker, due to the start up surge current.

2.10 INSTALLATION CHECKOUT

1. Check the cable connections from the power supply to the motherboard.
2. Inspect the cable from the operator control panel to the motherboard.
3. Be certain that all harness connectors are correctly plugged to the motherboard.
4. Check the motor lead connections to the terminal block at the edge of the motherboard.
5. Verify that all printed circuit boards are correctly seated into the card cage.

SECTION 3

OPERATION

SECTION 3

OPERATION

This section describes operating procedures. It provides specific instructions for tape handling, operator control functions, and the cleaning and maintenance procedures to be performed by the operator.

3.1 TAPE MARKERS

Magnetic tape must have some leader at the beginning of the reel to allow threading through the tape drive. The operator places two reflective markers on the tape which the drive senses as the beginning and end of the usable portion of the tape. The markers are small strips of aluminized plastic which are affixed to the base side of the tape.

1. Beginning-of-Tape marker (BOT) should be approximately 15 feet from the rim end of the tape. It must be parallel to the edge of the tape nearest the operator when the reel is mounted. The marker must be within 1/32 inch of the edge but not overlapping it.
2. End-of-Tape marker (EOT) is between 25 and 30 feet from the hub end of the tape. Its placement is similar to the BOT marker except that it is on the edge of the tape away from the operator.

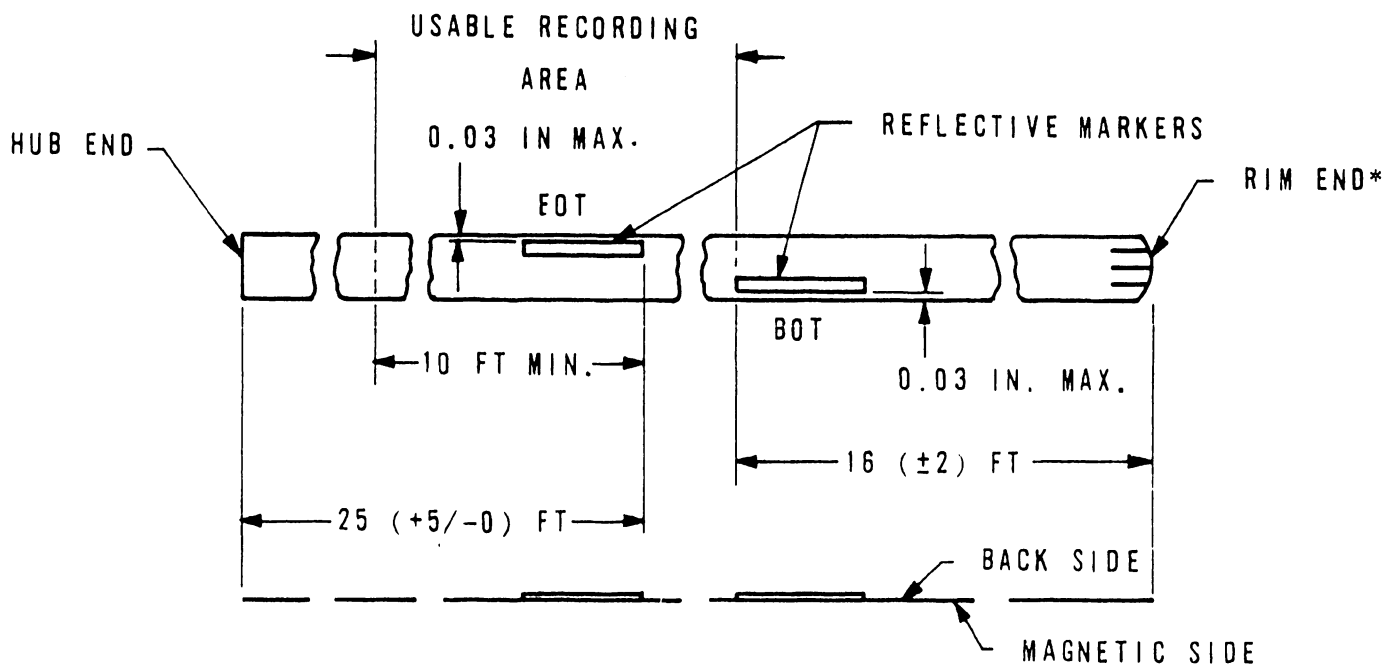

* PREPARED WITH IBM TAPE CRIMPER PN 2512063

Figure 3-1. ANSI Standard Tape Markers

3.2 FILE PROTECTION

Because a write operation erases any previous information on the tape, a file protection device is provided to prevent unintentional erasure. A plastic write-enable ring fits into a circular groove in the back of the tape reel. This ring is necessary to allow the tape drive to write on the tape. Without the ring only reading is possible; the tape file is protected from unintentional erasure.

The FILE PROTECT indicator on the Operator Control Panel indicates this condition. That is, when the indicator is on, the file is protected from erasure, only reading is possible.

3.3 OPERATOR CONTROL PANEL

The status indicators and operator controls in use during off-line operation are located on the Operator Control Panel shown below. The left bank consists of status indicators, and the right bank of pushbutton control switches.

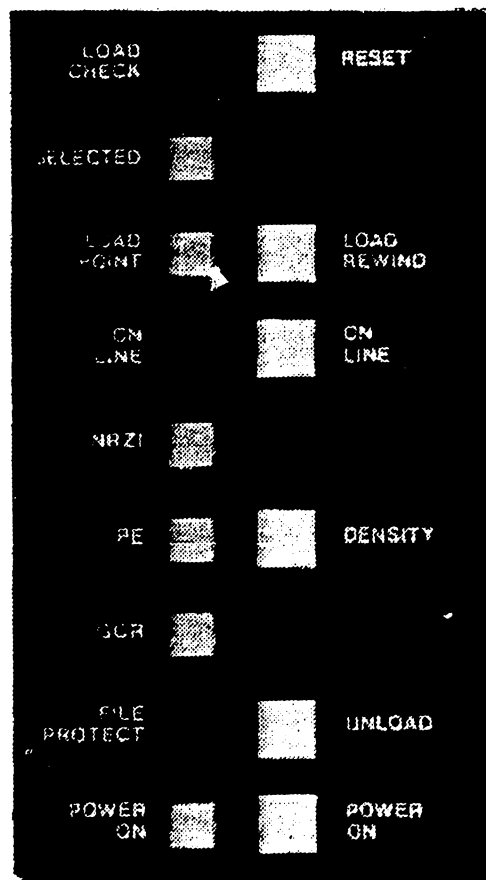

Figure 3-2. Operator Control Panel

3.4 OFF-LINE OPERATION

Basic off-line operation consists of loading and unloading tape, switching the unit on line, and monitoring tape unit status.

3.4.1 Loading Tape

If write capability is required, insert a write enable ring into the groove in the back of the file reel. File reels must conform to ANSI standard X3.40. Cartridges must conform to ANSI proposed standard X3B1/76-54.

1. Mount the file reel on the hub, with the write enable groove facing the tape unit.
2. Press the POWER ON switch if the unit is off; make certain the POWER ON indicator is on.
3. Press the LOAD REWIND pushbutton. The tape will load automatically, and stop with the BOT reflective marker at load point. The LOAD POINT indicator will turn on.

To load reels less than 10.5 inches in diameter follow steps 1 and 2 above. Then press the mini-reel load assist button located at the right between the reels. Insert the end of the tape into the threading orifice. The tape will be held in place by the air flow. Then depress the LOAD REWIND switch.

CAUTION

Avoid a prolonged time (several minutes) between pressing the mini-reel load assist button and the LOAD REWIND switch. This prevents excessive heating of the air valve solenoid.

If the load operation is unsuccessful, the unit attempts loading a second time. If the second attempt proves unsuccessful the loading sequence stops and the LOAD CHECK indicator lights.

3.4.2 Load Following Load Check

1. Press the RESET switch. The LOAD CHECK indicator will go out.
2. Press the LOAD REWIND switch to reinitiate the tape loading sequence.
3. If a load check condition occurs again, check the tape leader for creases or deterioration, or for a minimum length of 10 feet between the end and the BOT marker. If the tape leader cannot be repaired, manually load the tape as follows:
4. If a reel surround cartridge is used, remove it from the file reel.
5. Open the vacuum column cover by releasing the latches at the upper right and lower right corners of the cover.
6. Unwind approximately two feet of tape from the file reel.
7. Thread the tape through the path.

8. Wind the tape leader clockwise around the fixed reel hub three turns.
9. Close the vacuum column cover.
10. Press the LOAD REWIND switch to initiate the load sequence.

3.4.3 Rewinding Tape

Tape may be rewound by the formatter on-line, or by the operator off-line. In either case the tape operation is the same. The LOAD REWIND switch is disabled during on-line mode. In off-line (local) mode, press the LOAD REWIND switch. If there is enough tape pack on the fixed reel, the tape rewinds at high speed nearly to load point. Then it drives in reverse at normal speed and stops at the BOT marker. The LOAD POINT indicator lights.

3.4.4 Unloading Tape

Tape may be unloaded by the formatter on-line, or by the operator off-line. In either case the tape operation is the same. The UNLOAD switch is disabled during on-line mode. In local mode press the UNLOAD switch. The tape rewinds at high speed nearly to load point, then drives in reverse to load point at normal speed. At load point the tape unloads from the columns and winds slowly onto the file reel. The cartridge, if present, closes. If the tape is already at load point when the switch is pressed, the drive unloads without delay.

3.4.5 Transfer from On-Line to Off-Line Status

When the tape unit is operating in the on-line mode, pressing RESET will switch the unit to off-line (local) mode. Tape motion will cease and the ON LINE status indicator will go off.

3.5 ON-LINE OPERATION

3.5.1 Density Control

If the tape drive has the remote density select option, the formatter selects the density or mode. A drive with the manual density select option requires the operator to select the proper density with the DENSITY switch before going on-line. With either option, the tape drive must be at load point to change density. (See Paragraph 4.10)

3.5.2 On-Line Control

The On-Line (Ready) mode is initiated by the ON LINE switch. The switch may be depressed immediately after starting the load sequence with the LOAD REWIND switch. The tape unit will enter on-line status upon completion of the load sequence. The same results may be obtained by pressing the switch after the load sequence is complete.

When the tape unit enters on-line status, the ON LINE indicator lights. This signals the operator that the tape unit is ready to execute external commands when selected by the formatter. When the tape unit is selected by the formatter to execute a command, the SELECTED indicator lights.

3.6 OPERATOR MAINTENANCE

Basic operator maintenance requirements consist of cleaning the tape path, and replacing lamps. For more detailed procedure, refer to Daily Maintenance, Paragraph 5.1.1.

3.6.1 Cleaning the Tape Path

The tape path must be kept free of oxide, dust, and foreign matter which could cause data dropout or excessive wear of tape path components. The tape path should be cleaned once every eight hour shift.

Use only specified cleaning agents, since substitute cleaners may damage tape path components.

1. Unload the tape and remove the file reel.
2. Open the vacuum column cover by releasing the latches at the upper and lower right corners of the cover.
3. Moisten a lint-free cloth with TELEX Tape Transport Cleaner, A98X01723-01 and wipe clean all of the following tape path components:

- vacuum column cover
- vacuum columns and threading path
- air bearings
- roller tape guides
- ceramic tape guides
- BOT-EOT assembly lenses and mirror
- tape cleaner assembly
- magnetic head assembly
- capstan

CAUTION

The Supr-LiteTM capstan is extremely thin and light. Use care in cleaning. Clean with TELEX cleaner only. Do not use alcohol or other substitutes.

4. Close the vacuum column cover.
5. Clean the reel hubs and surrounding deck plate.

3.6.2 Lamp Replacement

All indicators on the Operator Control Panel contain flange based lamps reached by removing the lens cap. A lamp extractor is provided to simplify replacement. Replace lamps as follows:

1. Grasp the plastic lens cap between the thumb and forefinger and pull straight out.
2. Place a lamp extractor over the bulb, and pull the bulb straight out.
3. Insert the new bulb into its socket (use type T1-3/4 flanged base, 14-volt lamp).
4. Replace the lens cap over the lamp, pressing it into the OCP until it is securely seated.

SECTION

4

PRINCIPLES OF

OPERATION

SECTION 4

PRINCIPLES OF OPERATION

This section contains descriptions and diagrams which explain the principles of operation of the 6253 Tape Drive. It provides information of general interest to the user, provides a guide to the schematics in Section 7, and also serves as an aid in troubleshooting.

The section is divided into parts which parallel the functional assemblies of the tape drive:

● Power Supply	par. 4.2
● Pneumatic System	4.3
● Tape Deck	4.4
Capstan Drive System	4.5
Reel Drive System	4.6
Control Logic	4.7
I/O Interface	4.8
Data Electronics	4.9

Most of the figures in this section contain reference to corresponding elements on the appropriate logic diagram or schematic. This facilitates detailed circuit tracing.

4.1 GENERAL

The 6253 Tape Drive tape speed ranges from 50 to 125 inches per second. It can start and stop within the requirements of both 0.6 and 0.3-inch interblock gaps. Recording density and format are 800 bpi NRZI, 1600 bpi PE or 6250 bpi GCR depending on density selected.

All units autoload both open reel tapes and Easy Load I and II cartridges. A partial reel or minireel requires only that the operator place the end of the tape in the entrance to the tape path. The patented tape path utilizes vacuum columns with phototransistor tape sensing, fixed air bearings, digital tachometer rollers, and a capstan of extremely low mass to control tape motion. Only the read-write-erase head and tape cleaner blades touch the recording side of the tape. Rewind speed is 500 ips with tape in the columns, so it takes only a minute to rewind a 2400 ft. reel.

4.2 POWER SUPPLY

4.2.1 General

All of the power supply components are housed in an independent, ventilated metal cage mounted at the rear of the tape drive. Figures 1-2 and 2-4 show its general appearance. Primary input power enters at the rear panel through a 20-ampere connector. Circuit breakers, fuses, and output cables are on the front panel along with the covers of two printed circuit boards. The entire front panel hinges downward for access to the interior.

The supply consists of a regulated source of +5 volts, +12 volts, and -12 volts, a control circuit for this and for the pneumatic drive motor, and an unregulated source of +45 volts and -45 volts with a dump circuit.

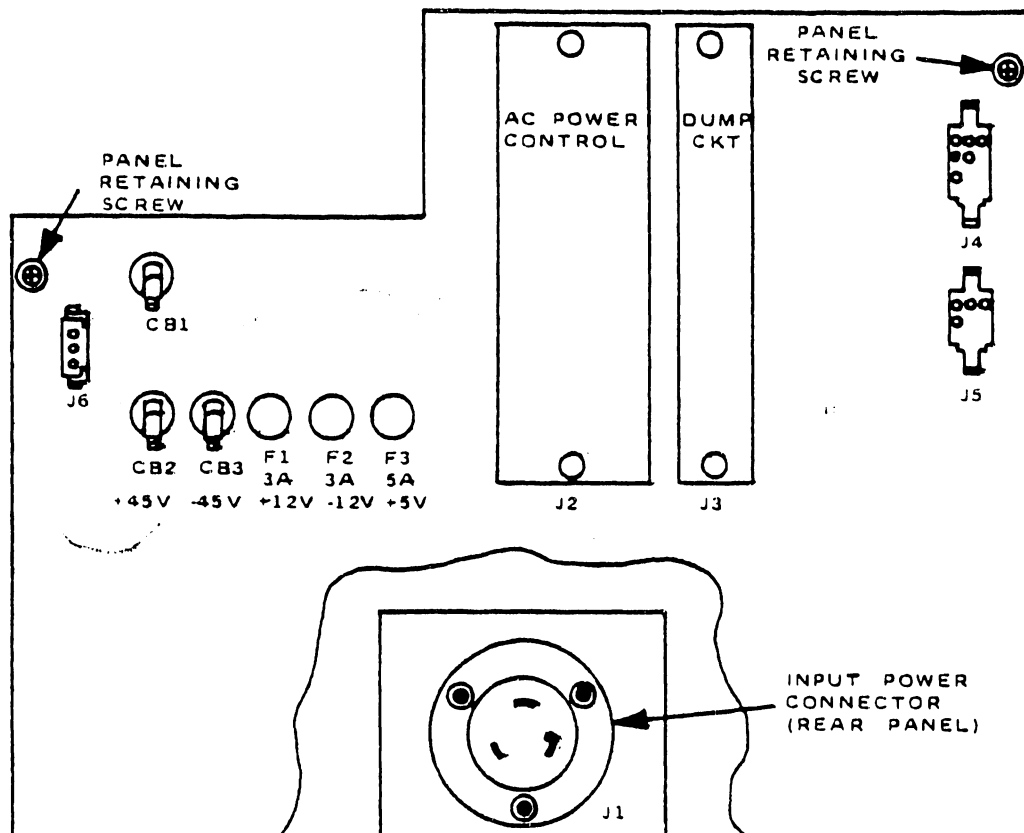

Figure 4-1. Power Supply Panel

Refer to Figure 4-1, and to schematic 92D20582. The input power connector J1 contains a hot line, neutral, and safety ground. FL1 is a bidirectional line filter that blocks noise on the power line. The main circuit breaker which follows opens both the phase and neutral lines. Note however that the breaker does not isolate the line filter.

4.2.2 AC Power Control

The AC Power Control circuit (J2) receives a power-on command from the operator, but delays execution until the input ac voltage is at a zero crossing. This reduces switching transients induced on the power line. The circuit enables the gate of Q3, a thyristor, which then applies power to the power supply PS1. An identical circuit applies power through thyristor Q4 to the pneumatic drive motor (VAC MTR) and 45-volt supply.

A .2A slow-blow fuse protects the circuit transformer primary and clips to the board itself. A 5A fuse protects the input to PS1. See Figure 5-2. The pneumatic motor control circuit includes a thermal safety switch S1 which closes above 160°F. This effectively shuts down the drive until the temperature drops and the switch opens again. The AC Power Control schematic is drawing 92D71800.

4.2.3 Regulated Power Supply

PS1 provides three regulated outputs for the tape drive: +5 volts (logic), +12 volts, and -12 volts. It protects against over voltage and senses each output remotely at the load for greater accuracy. Each output line contains a fuse mounted on the front panel. The power supply itself is a complete subassembly. Appendix B contains a schematic, assembly drawing, and parts list. Figure 5-1 is a photograph of the power supply.

4.2.4 Unregulated Power Supply

The remaining components of the supply constitute a source of +45 volts and -45 volts for the capstan and reel motors. The circuits are the same except for polarity. A high voltage transformer receives the pneumatic motor input through Q4, and neutral from CB1. A rectifier, filter, and circuit breaker CB2 complete the positive supply. The Dump Circuit (J3) compares the +45 volts to a reference derived from the +12-volt supply. Should the voltage exceed a present level, the circuit turns on Q1 shunting the voltage across R1 and dissipating the excess energy. This overvoltage could develop momentarily during dynamic braking when the motors act as generators. The Dump Circuit schematic is 92D71813.

4.3 PNEUMATIC SYSTEM

The tape deck requires an air flow at several points along the tape path in order to thread tape automatically. It also needs a vacuum applied to the columns during normal running. The pneumatic system provides air pressure and vacuum for these requirements and others, by means of two blowers operated by a single motor. Air moves through a system of tubing and valves on the tape deck which regulate the volume and destination. All pneumatic components and orifices on the tape deck are identified on Figures 4-2 and 4-3. The Pneumatic System Diagram is 92D20603. Also, Figure 5-14 calls out pneumatic components only.

4.3.1 Pneumatic Supply

The pneumatic supply or blower assembly is shock mounted at the rear of the tape drive. It consists of a 3/4-hp, single-phase motor and two blowers coupled by drive belts. The motor is strapped for either 115 or 230-volt operation. A four stage, pulley driven, centrifugal blower supplies pressure to the system. The head developed is about 50 inches of water. A similar blower develops the vacuum required. This is a three stage blower producing about 30 inches of water. The otherwise unused exhaust from the vacuum blower provides cooling to the reel motors. Note that the belts and pulleys (under a safety cover), and the input connector to the power supply are the only components that require access to the rear of the tape drive.

4.3.2 Diverter Valve

The output of each blower connects to diverter valve V1 by a 1-1/2-inch, reinforced, flexible hose and plastic fitting. The diverter valve is a two-path, two-position air switch. One path carries pressure, the other vacuum. One position is thread mode, the other run mode. Each of the four ducts has a butterfly valve with linkage to a solenoid and return spring. The system diagram shows the solenoid de-energized, the diverter valve in normal run mode. In this mode air pressure goes to the three air bearings, and vacuum to the columns, and tape cleaner. The solenoid energizes during thread mode, and the valve switches to its other state. Pressure goes to all of the threading jets and slots, vacuum to the hub on the lower reel. In both modes the inlet manifold supplies air pressure to the pneumatic reel latch.

4.3.3 Cartridge Valve

Autoload with the reel mounted in a cartridge requires a somewhat different arrangement of threading air. The jets and slot surrounding the cartridge are ineffective. Air pressure now goes inside the cartridge into its own plenum and series of angled jets, directed there by cartridge valve V6. An alignment tab on the cartridge itself physically transfers this valve as the operator mounts the reel.

4.3.4 Metering Valves

Three simple but effective gate valves provide the adjustment necessary to fine tune the autoloading process. Note the air bleed hole in V8 making it unique. Refer to paragraph 5.2.17 for the purpose of each valve and orifice. The settings made at the factory rarely need to be changed, but the adjustment procedure is given in the maintenance section.

4.3.5 Differential Switches

There must be some means of signaling the control logic when certain pneumatic events occur. Four differential switches provide both the sensing and the signaling. Pressure applied to the end marked P, or vacuum to the other end, closes a circuit between the ends. S1, S2, and S4 monitor vacuum, S3 monitors pressure, so switch orientation is significant. S1, S3, and S4 switch at 15 inches of water, S2 switches at 10, so there are two switch types.

4.4 TAPE DECK

Figures 4-2 and 4-3 identify the tape deck components of concern in this manual. The main exception is the card cage and its printed circuit boards which are detailed in the remainder of this section.

4.5 CAPSTAN DRIVE SYSTEM

The purpose of the capstan is control of tape motion past the read-write-erase head. This control is effective in both directions including high speed rewind. The capstan drive system is a linear servo using feedback from an analog tachometer to define tape speed. Tape must be loaded in the vacuum columns to enable the servo. The capstan servo imposes no restrictions on the program.

Figure 4-4 shows the servo in simplified form. A normal forward or reverse tape motion command results in a linear ramp voltage from a generator. This connects to the summing point with amplitude set by the SPEED adjustment. The preamplifier and power amplifier supply current of either polarity to the capstan. The motor accelerates at a constant rate to the running speed determined by the power amplifier. Then an analog tachometer on the capstan shaft adds speed information to the summing point to maintain precise speed. Also, a sample of the motor current itself returns to the summing point for additional control. A rewind command substitutes a different ramp generator which results in a longer ramp and much higher capstan speed. This long ramp connects to the reel servo as a field ramp.

The analog tachometer output also feeds through a precision rectifier to a voltage-to-frequency converter. This generates pulses at a frequency proportional to tape speed. One pulse equals .0047 inch of tape. Output from this digitized tachometer helps to position tape in PE and GCR formats and to track loop motion in the reel servo.

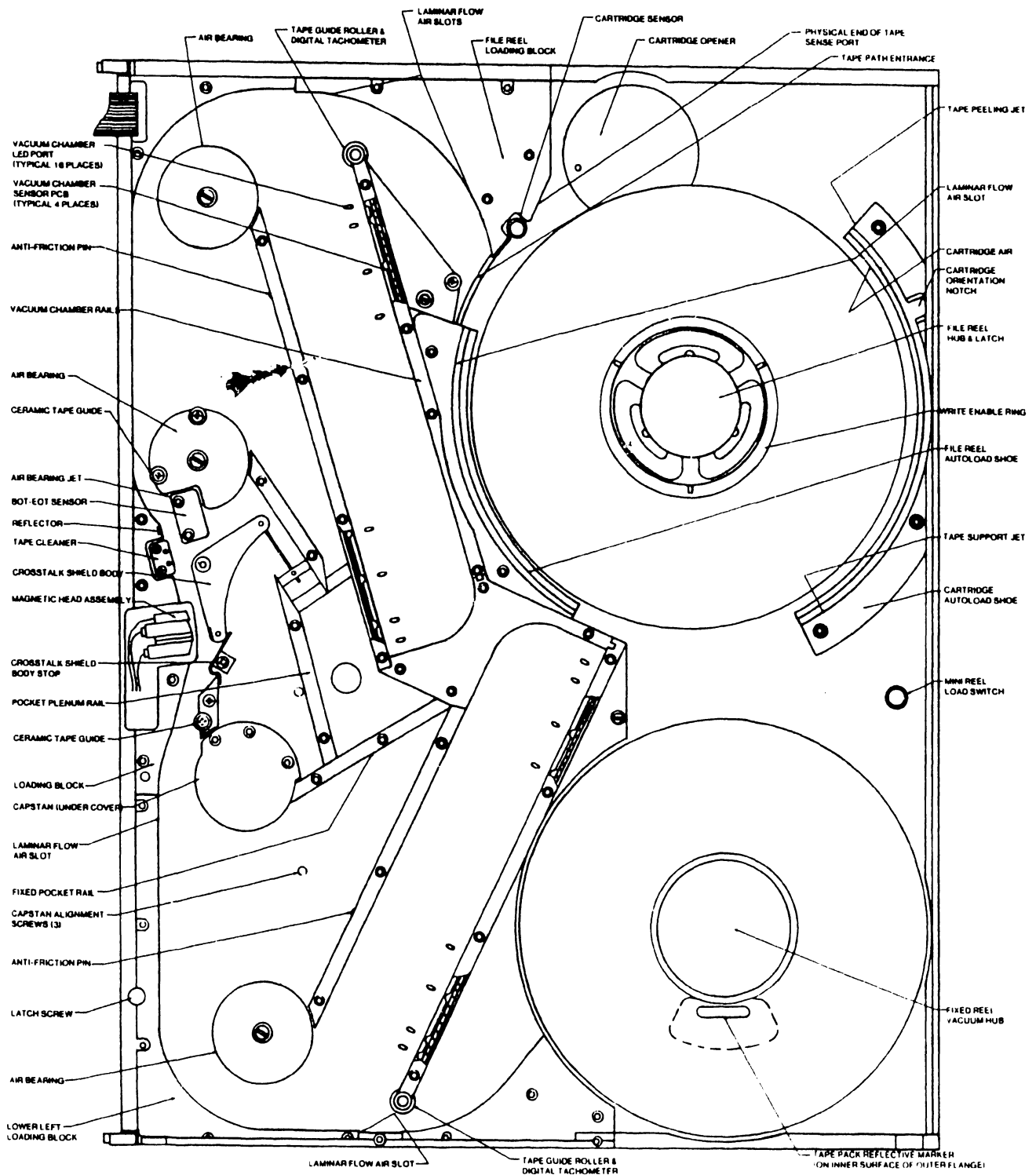

Figure 4-2. Tape Deck Components, Front

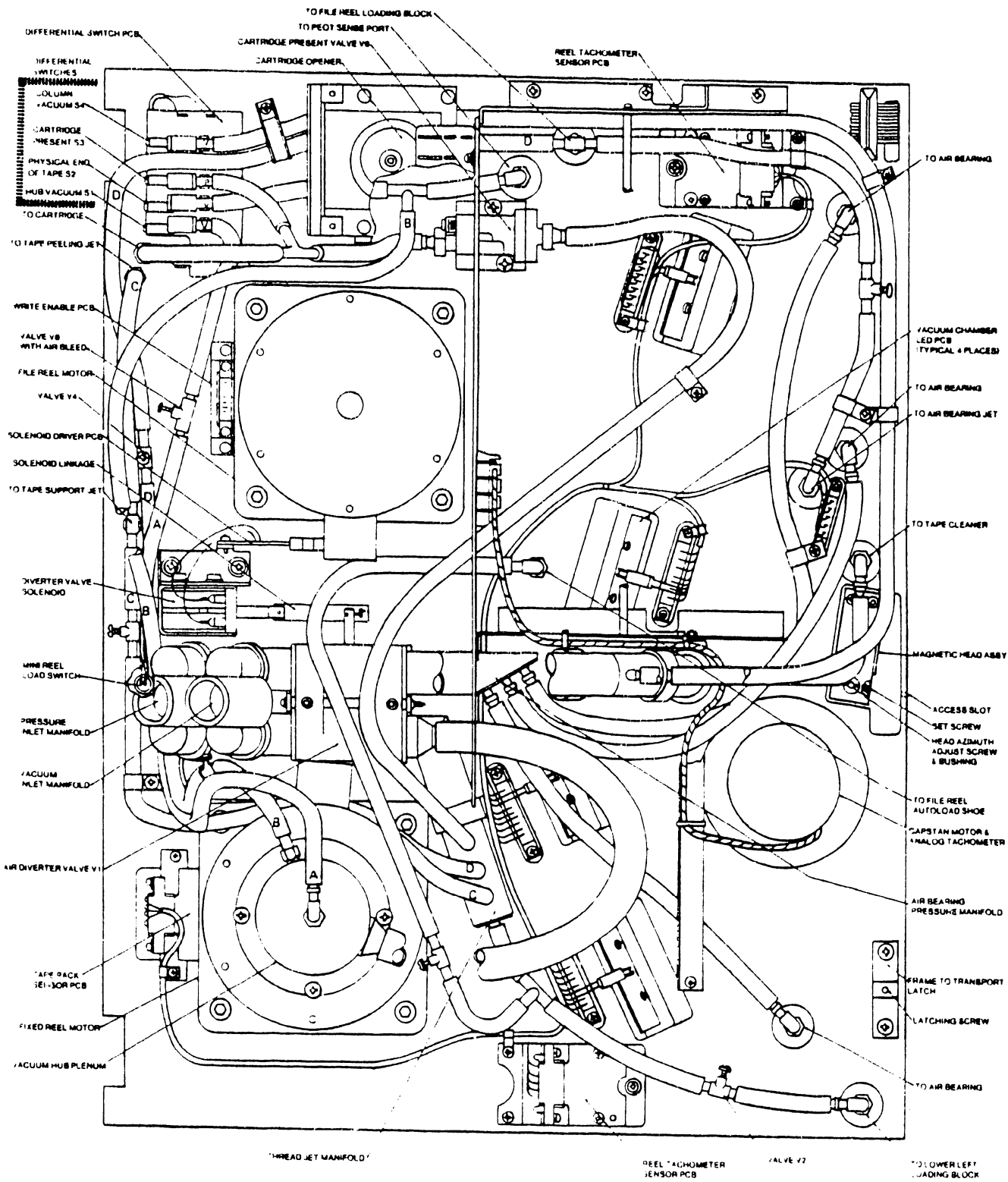

Figure 4-3. Tape Deck Components, Rear

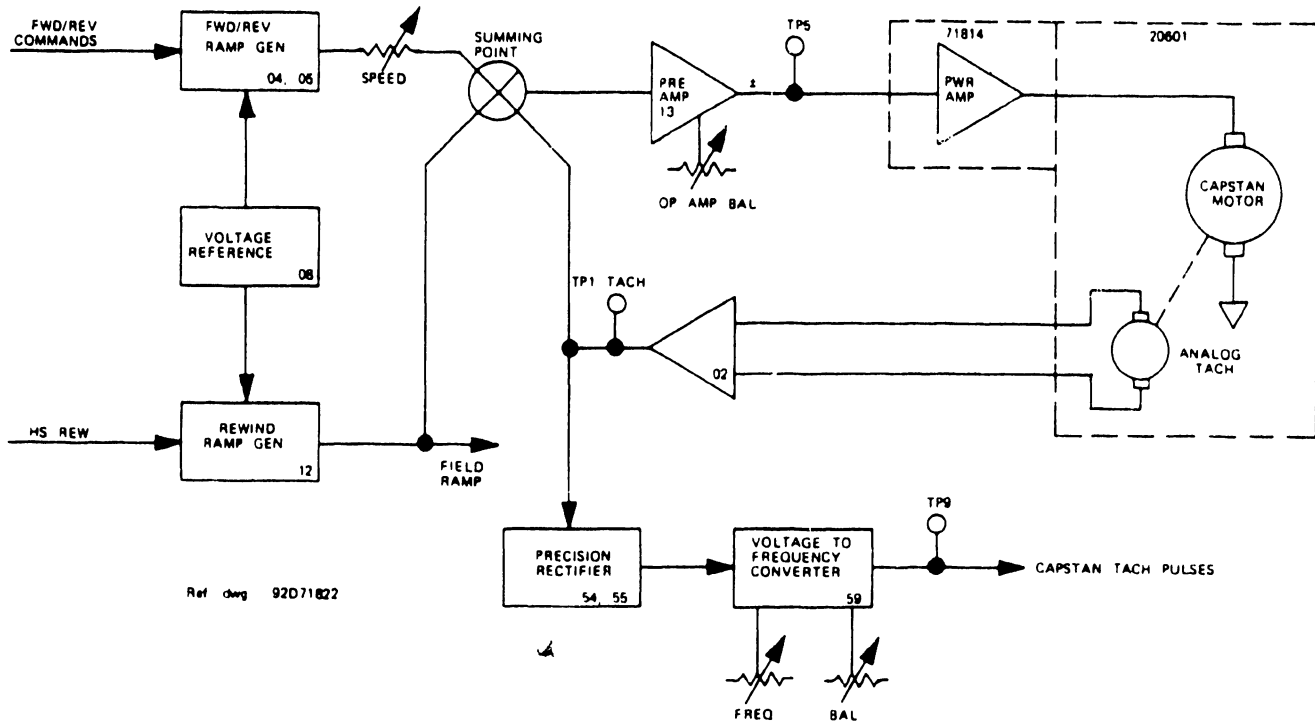

Figure 4-4. Capstan Servo Simplified Circuit

4.6 REEL DRIVE SYSTEM

The reel drive system is a switching servo utilizing the inductance of the motor armature to determine the switching speed. The tape deck contains two independent servos, one for each reel. The direction and average speed correlate with the direction and speed of the capstan.

A preamplifier and power amplifier supply current of either polarity to the motor armature to drive the reel in either direction. The polarity comes through servo logic from tape motion commands and tape position sensors. An analog switch changes these logic levels into proper analog voltages for the preamplifier. This voltage determines the basic speed of the motor. A sample of the motor current modifies the preamplifier input to give precise speed control.

Figure 4-5 shows the simplified circuit of the file reel motor, and refers to the logic diagrams and schematic. The fixed reel motor circuit is very similar.

4.6.1 Reel Motor and Drive Amplifiers

The inductance of the reel motor armature causes the drive current to increase exponentially when the preamplifier switches on. A low value resistor in series with the armature feeds back to the preamplifier a sample of this increase. When this current reaches a certain upper level, the preamplifier switches off. However, armature current continues through a discharge diode, decreasing exponentially until it falls below a certain lower level. At this value the preamplifier switches on again. This cycle repeats at a 3 to 5 KHz rate, and the high drive current of 22 amperes shows a ripple of 2 amperes.

The analog signal at the summing point varies between +10 volts and -10 volts. This input results in output to the armature such that voltage (drive current) controls speed and polarity controls direction of the reel motor.

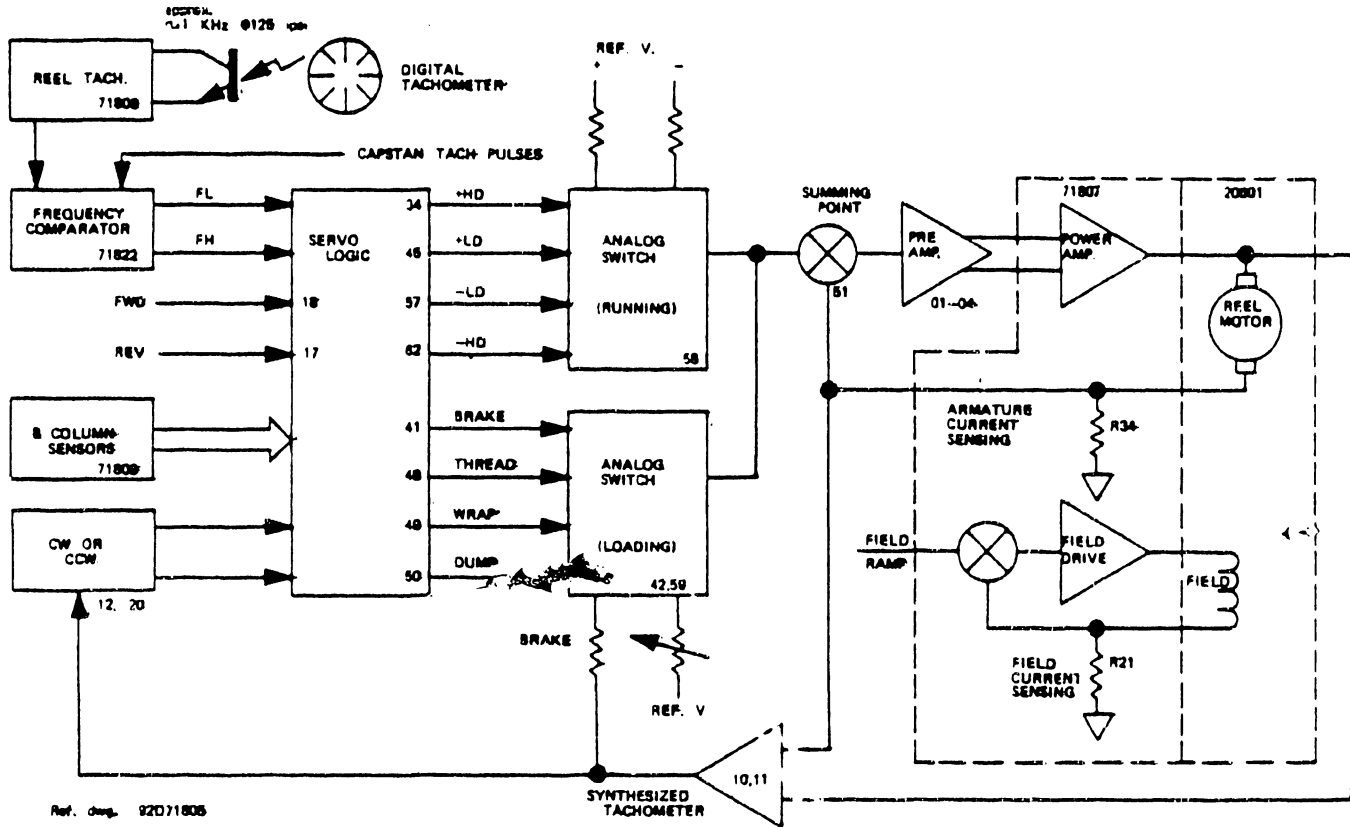

Figure 4-5. Reel Servo Simplified Circuit (File reel)

4.6.2 Analog Switching

A group of analog switches change the servo logic outputs into the correct analog voltage at the preamplifier input. A logic input to any one of the analog switches selects a reference voltage through a resistor to give the correct voltage and polarity for that input function. One group of inputs respond to forward and reverse tape motion commands along with information from eight sensors which give the position of the tape loops in the vacuum columns. These inputs select fixed voltage outputs. Another group comes into play during tape loading and unloading. These inputs select adjustable voltages.

4.6.3 Motor Torque

Normal start-stop, read-write operation requires that the reel motor produce high torque and rapid acceleration. Rewind at 500 ips requires low torque and mild accelerations. These opposing requirements are met by programming the motor field to change the motor torque constant. The field drive supplies high current for start-stop operation, but ramps down to a low level as the capstan drives slowly up to rewind speed. The torque constant of the reel motor is changed by a factor of about 4 to 1.

4.6.4 Vacuum Column Sensors

Near the entrance to each vacuum column is a group of four light emitting diodes and phototransistor sensors. There is another group of four LED-sensor pairs near the bottom of each column. Tape covers or uncovers various sensors as the loop moves up and down in the column, so these sensors indicate to the servo logic the position of the loop in the column. Refer to Figure 4-2.

4.6.5 Reel Tachometer

A tape guide roller is visible at the entrance to each vacuum column. At the other end of the roller is a digital tachometer, hidden from view in the deck plate. Figure 5-10 shows a cut-away drawing of this assembly. Alternate black and reflective segments on the tachometer disc, sensed by an LED-sensor pair, produce a pulse train as the tape moves over the roller. This digital tachometer provides accurate tape speed information to the servo logic. See Figure 4-5.

The reel and capstan tachometer signals come together in a frequency comparator. This determines if the tape speed at the entrance to the vacuum column is higher (FH) or lower (FL) than the capstan. The comparator is basically a pair of 5-bit binary counters (21,32) reset by the reel tachometer pulses and clocked by the capstan tachometer pulses which were converted from analog.

4.6.6 Servo Logic

The servo logic combines the Frequency High or Frequency Low signal with direction information from the reel motor itself through a synthesized tachometer to determine if the motor should be driven clockwise or counterclockwise. For example, if the loop is moving fast up (FU) and is near the top of the column, it is liable to loop out. The servo initiates a command to move the loop back toward the middle of the column. It handles a fast down (FD) loop in a similar manner. As soon as tape speed reaches 90% of its nominal value, the servo reduces armature current to that required for slow acceleration. The servo maintains this current until the tape reaches its nominal speed.

The synthesized tachometer also controls tape speed during load and unload. It senses motor current, derives a signal proportional to motor speed, and applies it as negative feedback through R28 (file reel) to the summing point. Braking is also directly related to this feedback signal. If braking is needed either in the normal column brake zone, or because tape bottomed or looped out, the analog switch increases gain in the feedback loop, and heavy braking occurs until reel motion stops.

4.6.7 Vacuum Bias

Another analog switch function, not shown in Figure 4-5, is active as long as tape is in the columns (COLVAC). This applies a constant bias, a small, additional motor current which tends to pull tape out of the column. Since the column vacuum tends to pull tape to the bottom, the bias exactly counterbalances it. The loop stabilizes when the capstan stops.

Figure 4-6 summarizes all this column action and relates details to particular logic gates in the logic diagram.

4.6.8 Power Loss Relay

As a fail safe feature a relay contact shorts the reel motor armature if power should fail. This provides maximum dynamic braking. The relay contacts appear only on the System Schematic 92D20651. The coil connects to -12 volts.

FILE REEL COLUMN (SHT 2)					FIXED REEL COLUMN (SHT 3)					
DIRECTION		DRIVE	GATE CONDITION (gate)		ZONE	DIRECTION		DRIVE	GATE CONDITION (gate)	
BRAKE		LOOPED OUT				BRAKE		LOOPED OUT		
↓	CW	HD	34		SAFETY	↓	CCW	HD	84	
↓	CW	HD	32	FU	ACCEL.	↓	CCW	HD	82	FU
↓	CW	LD	45B	$\overline{FU} \cdot \overline{FD}$ (31) + STOP * (56)		↓	CCW	LD	98B	$\overline{FU} \cdot \overline{FD}$ (81) + STOP (109)
RUNNING POINT						RUNNING POINT				
↓	CW	HD	33	FU	ACCEL.	↓	CCW	HD	83	FU
↓	CW	LD	45A	$\overline{FU} \cdot \overline{FD}$ STOP (52.1)		↓	CCW	LD	98A	$\overline{FU} \cdot \overline{FD} \cdot \text{STOP}$ (94.1)
			BRAKE 39	FD · REV					BRAKE 87	FD · REV RAMP
BRAKE 27 $\overline{WRAP} \cdot \overline{BKWRP}$ DECEL.						BRAKE 91				
BRAKE 37 FU · REV RAMP						BRAKE 89 FU · REV				
↑	CCW	LD	57A	$\overline{FU} \cdot \overline{FD} \cdot \text{STOP}$	ACCEL.	↑	CW	LD	105A	$\overline{FU} \cdot \overline{FD} \cdot \text{STOP}$
↑	CCW	HD	60	FD		↑	CW	HD	110	FD
RUNNING POINT						RUNNING POINT				
↑	CCW	LD	57B	$\overline{FU} \cdot \overline{FD}$ + STOP		↑	CW	LD	105B	$\overline{FU} \cdot \overline{FD}$ + STOP
↑	CCW	HD	61	FD	ACCEL.	↑	CW	HD	111	FD
↑	CCW	HD	62		SAFETY	↑	CW	HD	112	
BRAKE BOTTOMED						BRAKE BOTTOMED				

HD = HIGH DRIVE (22A)
 LD = LOW DRIVE (10A)
 FU = FAST UP
 FD = FAST DOWN
 $\overline{12}$ = SENSOR 1 COVERED, SENSOR 2 UNCOVERED
 * STOP = REV · FWD GATE 19

REF. DWG. 92D71805

Figure 4-6. Vacuum Column Sensor Control of Reel Motors

4.7 CONTROL LOGIC

The major functions of the Control Logic are controlling autoload, rewind, unload, and on-line tape motion. The circuit includes a tester by which the operator may exercise all tape motion off line.

Autoload involves finding the physical end of the tape on the file reel or opening the cartridge, threading the tape through the tape path, around the fixed reel hub, and dumping (loading) tape into the vacuum columns. Then the capstan moves the tape to load point.

Commands for forward and reverse tape motion, rewind or unload come from two sources. While the tape drive is loaded and off line, the operator may command all tape motion with controls on the built-in tester, and rewind or unload with front panel switches. When the unit is on line, all commands come from the formatter across the interface.

4.7.1 Autoload

A load sequencer controls all functions of the autoload process. Refer to Figure 4-7 Load Sequencer Flow Chart. Each block is a sequencer state and indicates the action of the reels during that state. Each connection is an event in the process from a switch or sensor. A normal load sequence begins at REST state with the LOAD REWIND pushbutton on the Operator Control Panel, and runs to completion automatically, returning to REST. Should the tape fail to load, the sequencer wraps it back onto the file reel and tries threading it a second time.

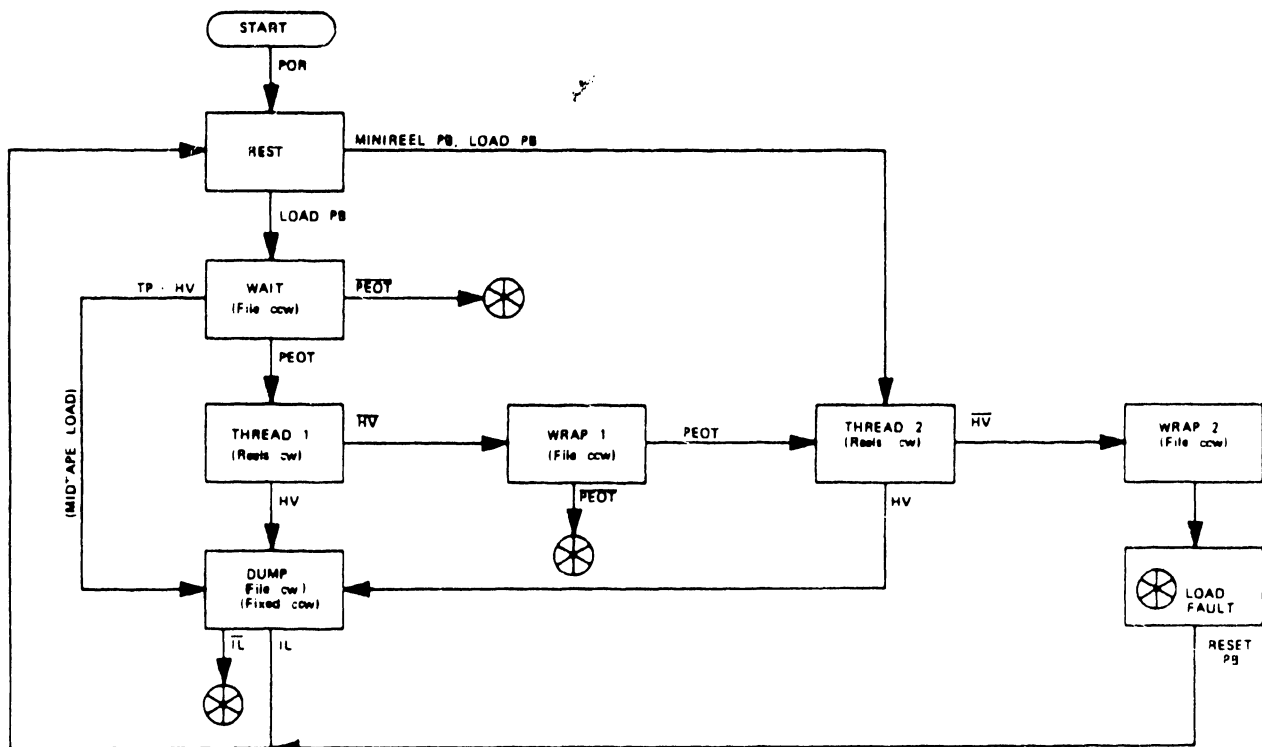

Figure 4-7. Load Sequencer Flow Chart

The load sequencer is embodied in four logic blocks. See the simplified logic diagram Figure 4-8. At its heart is a group of three binary latches which can store a count from 0 to 7. A binary decoder activates one of its eight outputs in response to this count to become the current sequencer state. It is this state which controls the action of the drive through a solenoid and five motors. The sequence logic accepts pushbutton commands, senses tape progress, considers the current sequencer state, and then determines the next state.

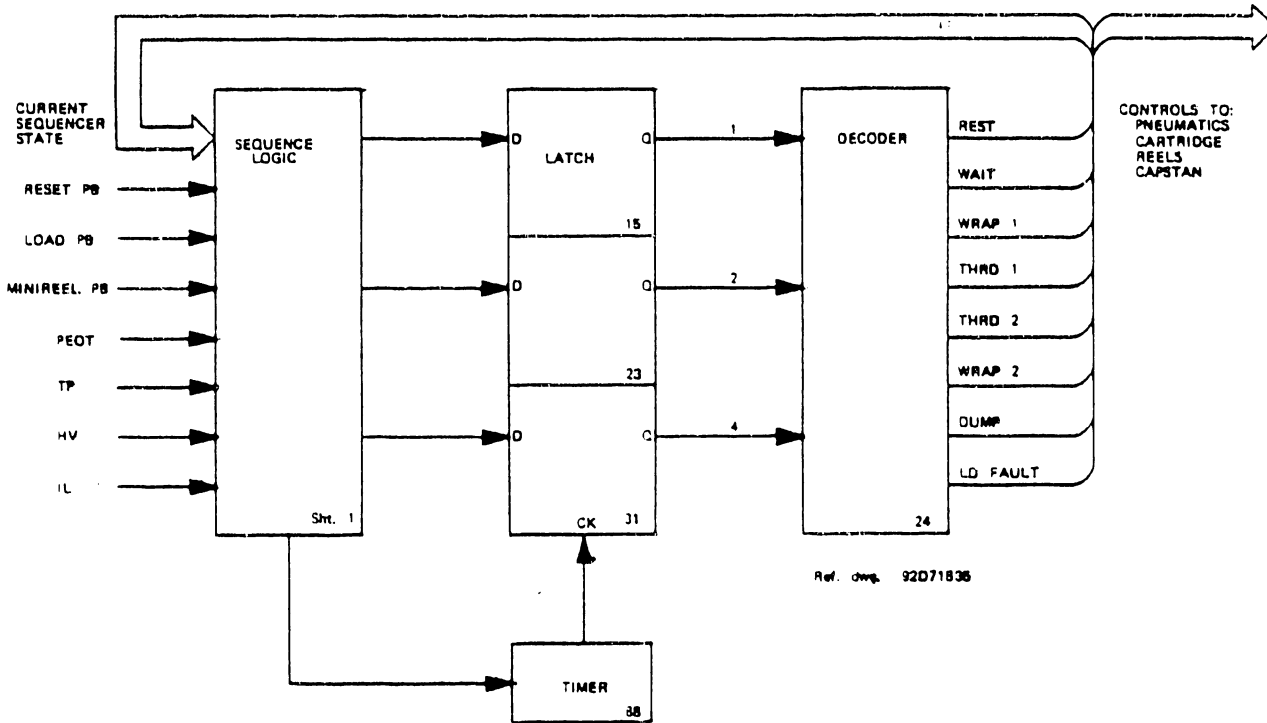
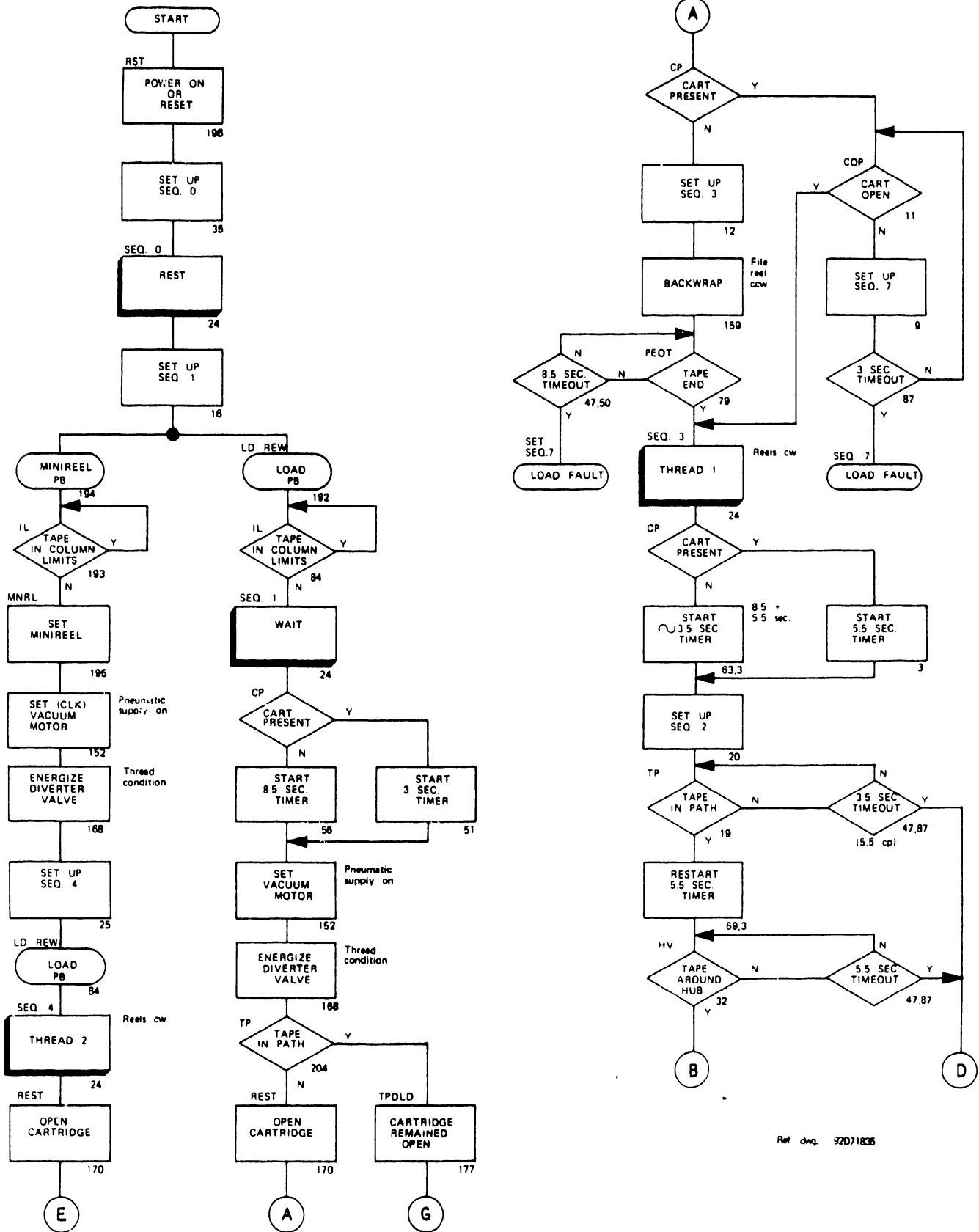

Figure 4-8. Load Sequencer Simplified Logic

The Autoload Flow Chart presents a detailed description of the autoload process. The heavy blocks show each of the eight sequencer states and the latch count which produces it. The number at the bottom of each block refers to the particular logic element which performs the function. This relates the flow chart to Control Logic Diagram 92D71835 in the Logic/Schematics section. Abbreviated logic signal names are defined in Appendix B.



Ref. dwg. 92071836

Figure 4-9. Autoload Flow Chart 1 of 4

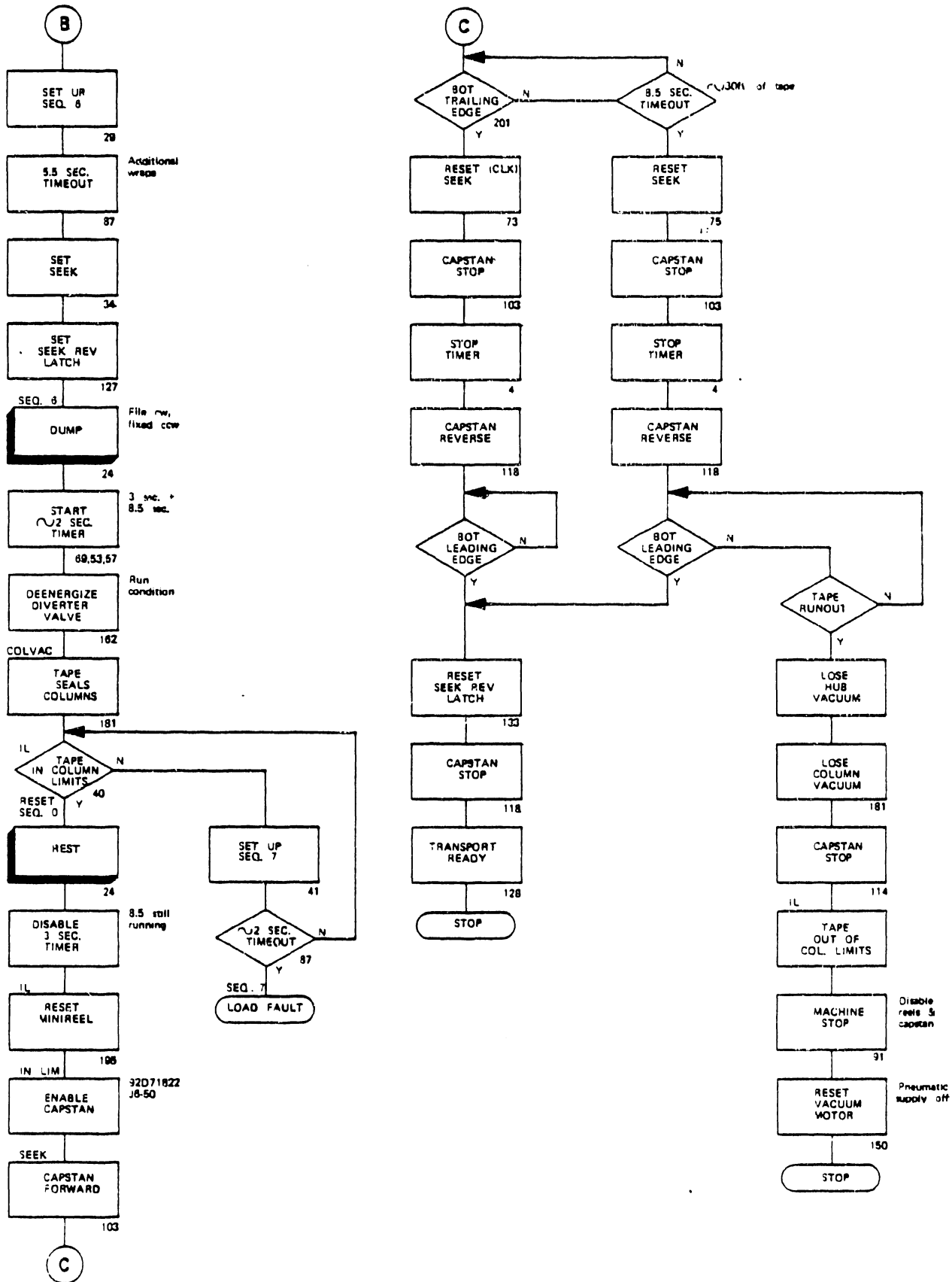

Figure 4-9. Autoload Flow Chart 2 of 4

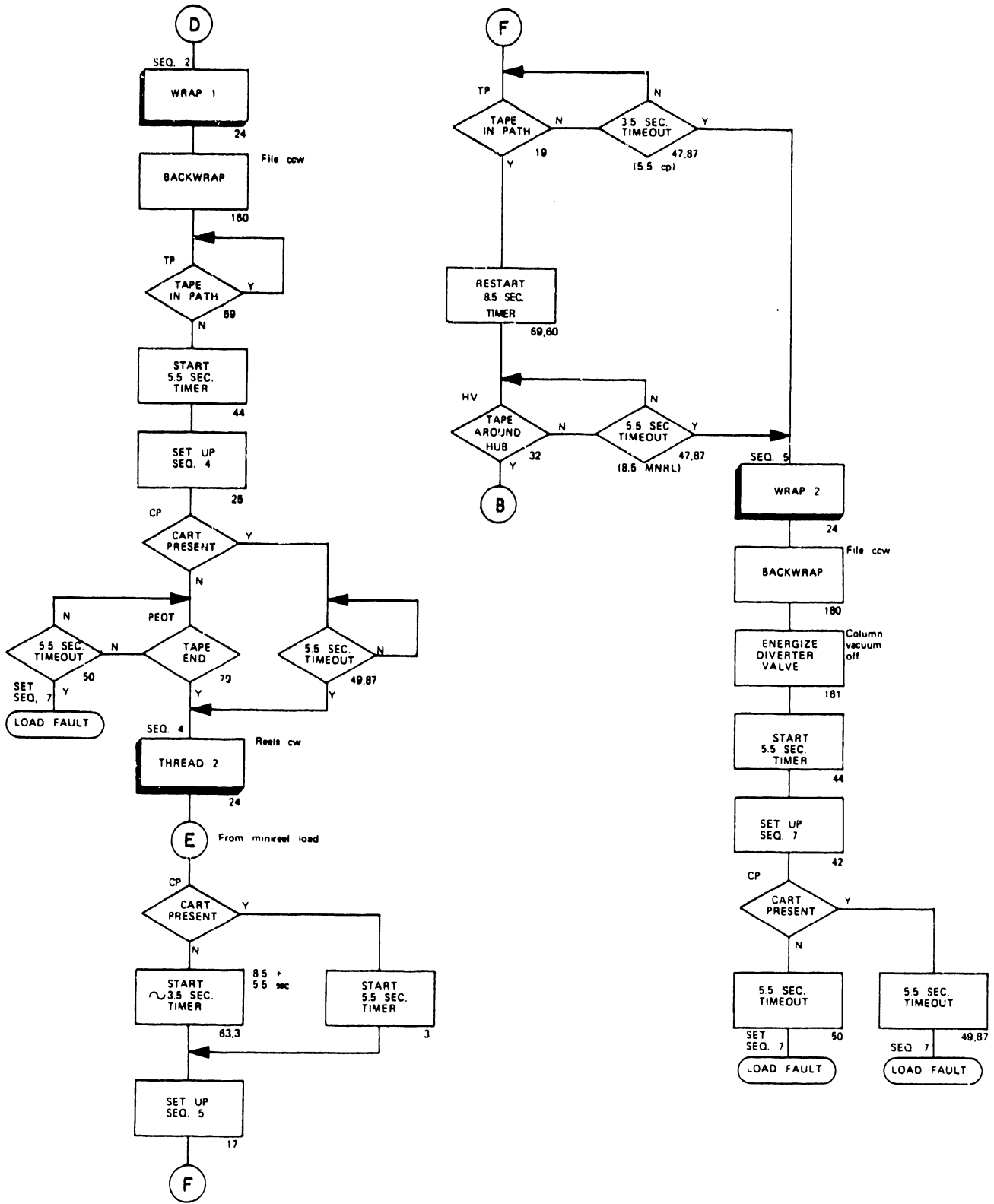

Figure 4-9. Autoload Flow Chart 3 of 4

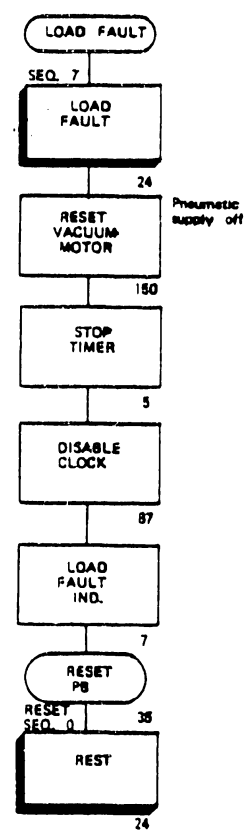
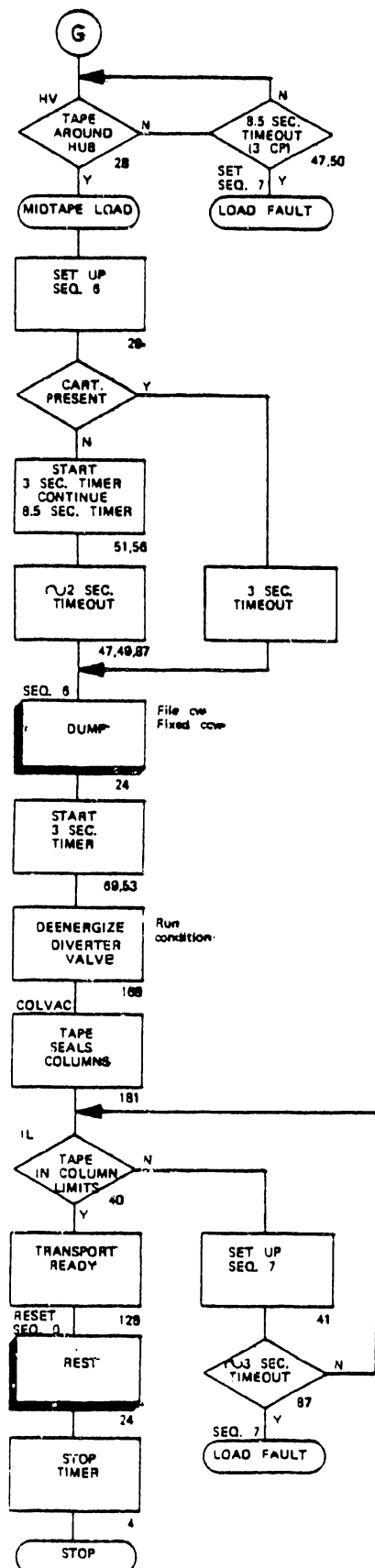

Figure 4-9. Autoload Flow Chart 4 of 4

4.7.2 Autoload Timing

Some typical timing relationships appear in the eight samples of autoload in Figure 4-10. These charts are derived from oscilloscope traces where the sweep speed is five seconds per major division (one second per tick mark). Each states the condition under which it was made. The same signals appear in each chart, except that No. 5 shows Tape Present instead of Load Fault.

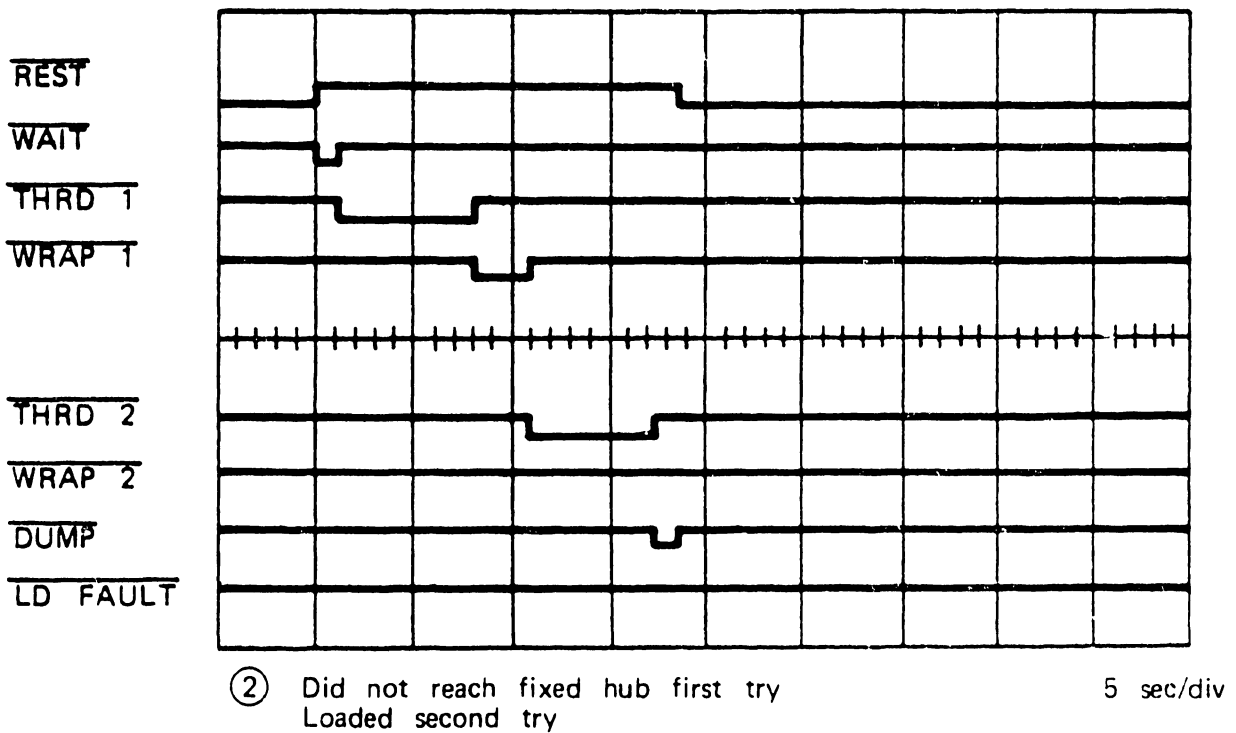
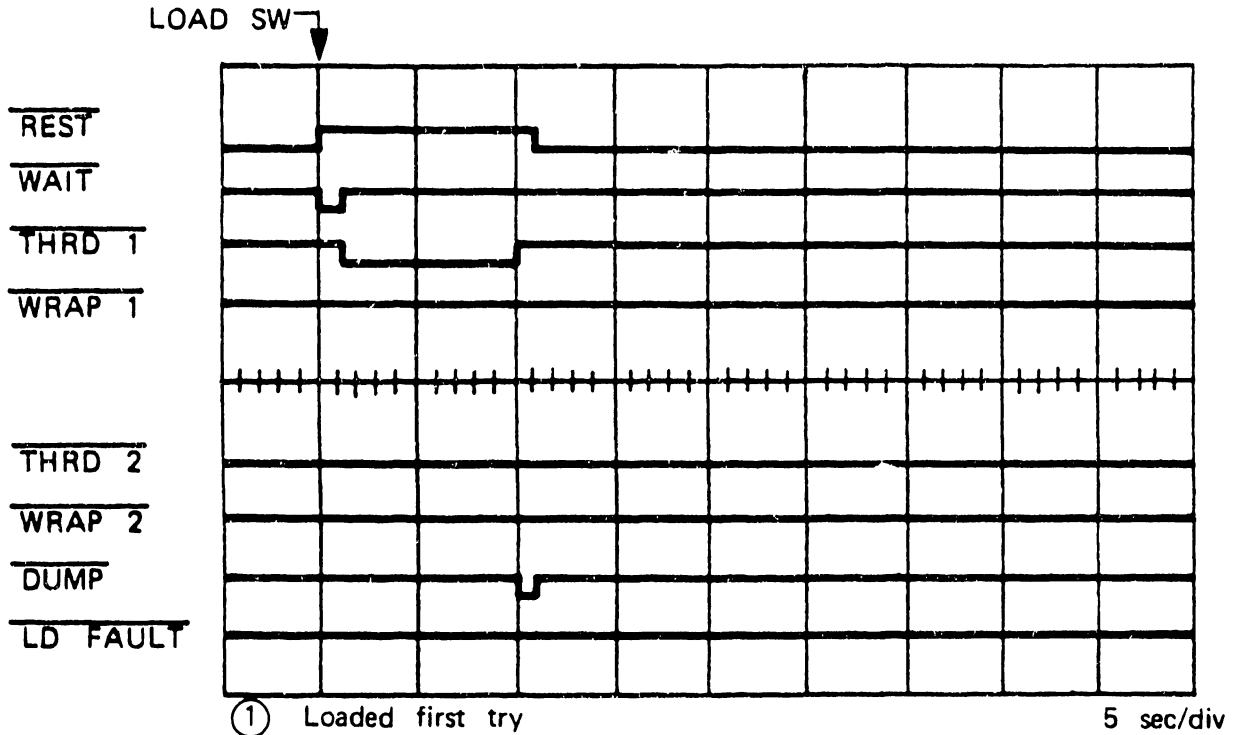
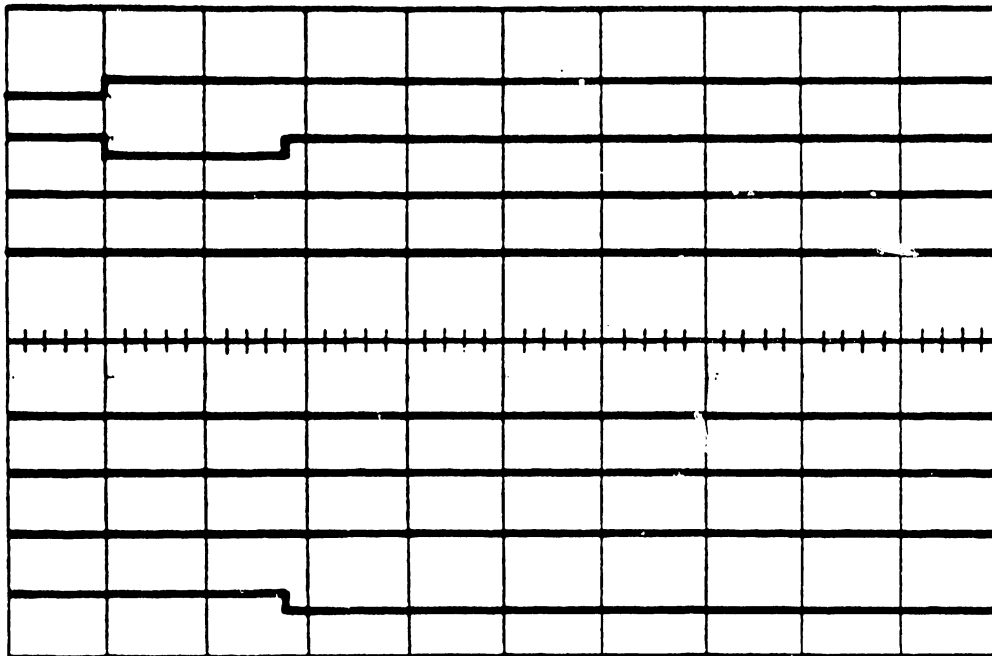

Figure 4-10. Autoload Timing Charts 1 of 4

REST
WAIT
THRD 1
WRAP 1

THRD 2
WRAP 2
DUMP
LD FAULT



③ Did not sense PEOT

5 sec/div

REST
WAIT
THRD 1
WRAP 1

THRD 2
WRAP 2
DUMP
LD FAULT

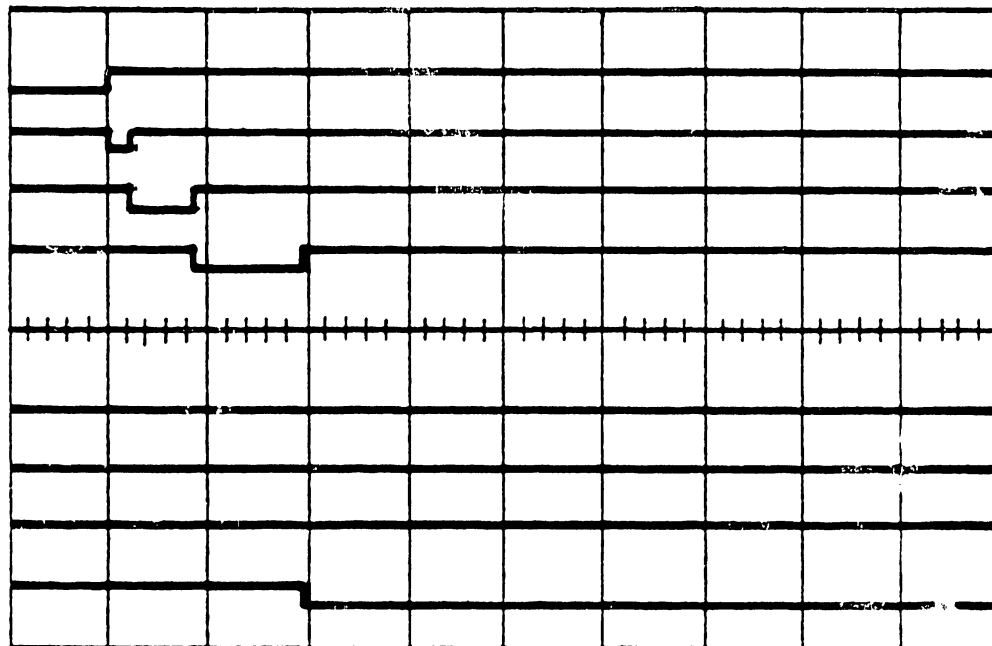

④ Did not reach TP first try
Did not sense PEOT second try

5 sec/div

Figure 4-10. Autoload Timing Charts 2 of 4

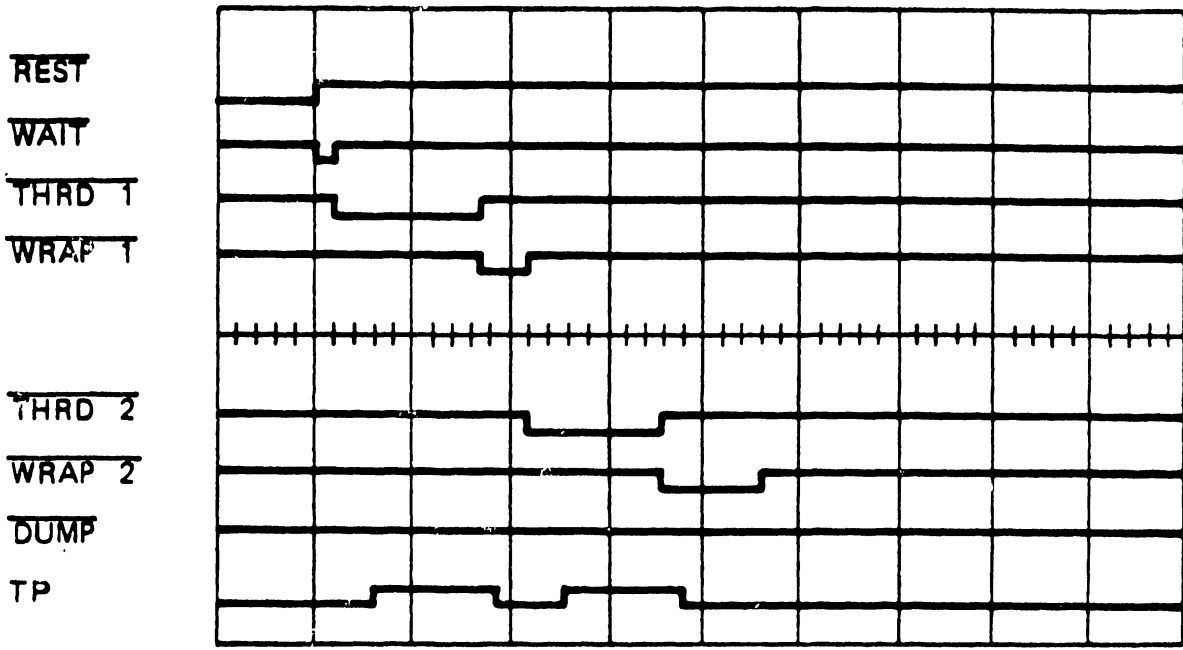

⑤ Did not reach fixed hub in two tries 5 sec/div

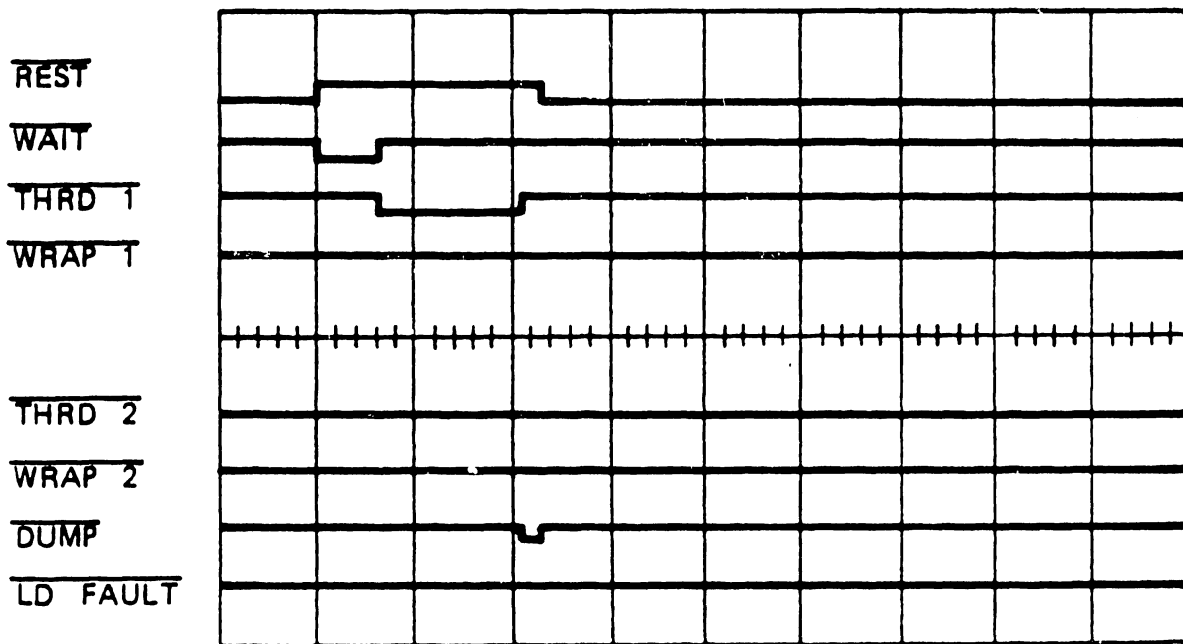

⑥ Cartridge present Loaded first try 5 sec/div

Figure 4-10. Autoload Timing Charts 3 of 4

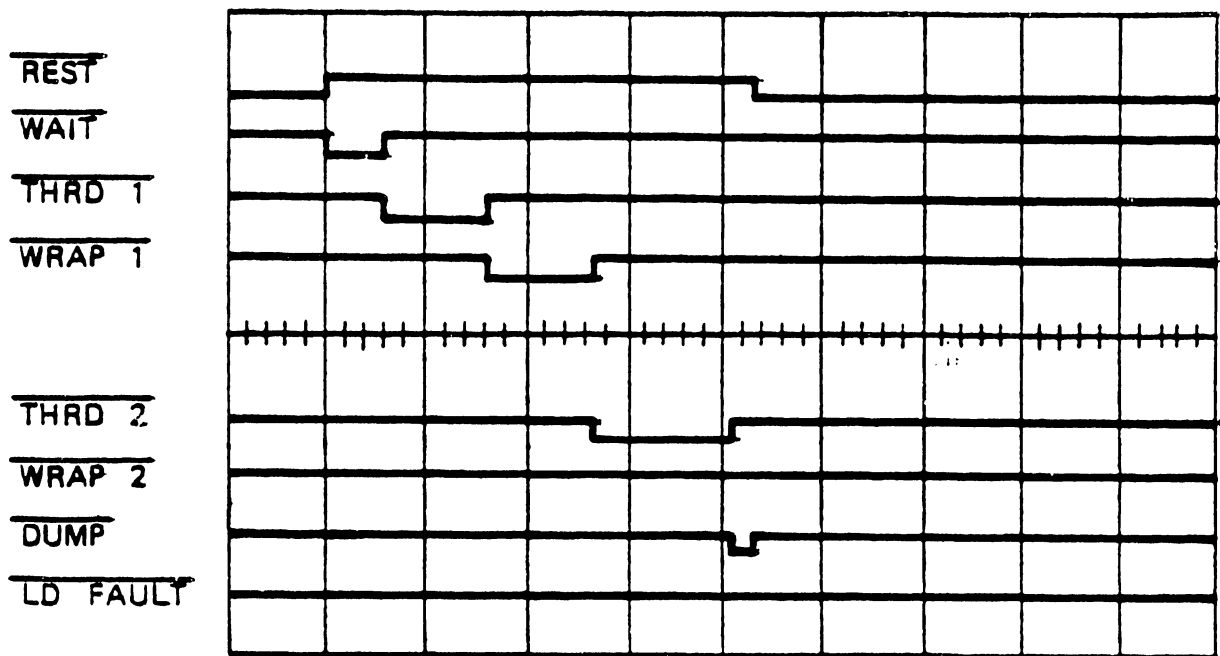

⑦ Cartridge present Loaded second try 5 sec/div

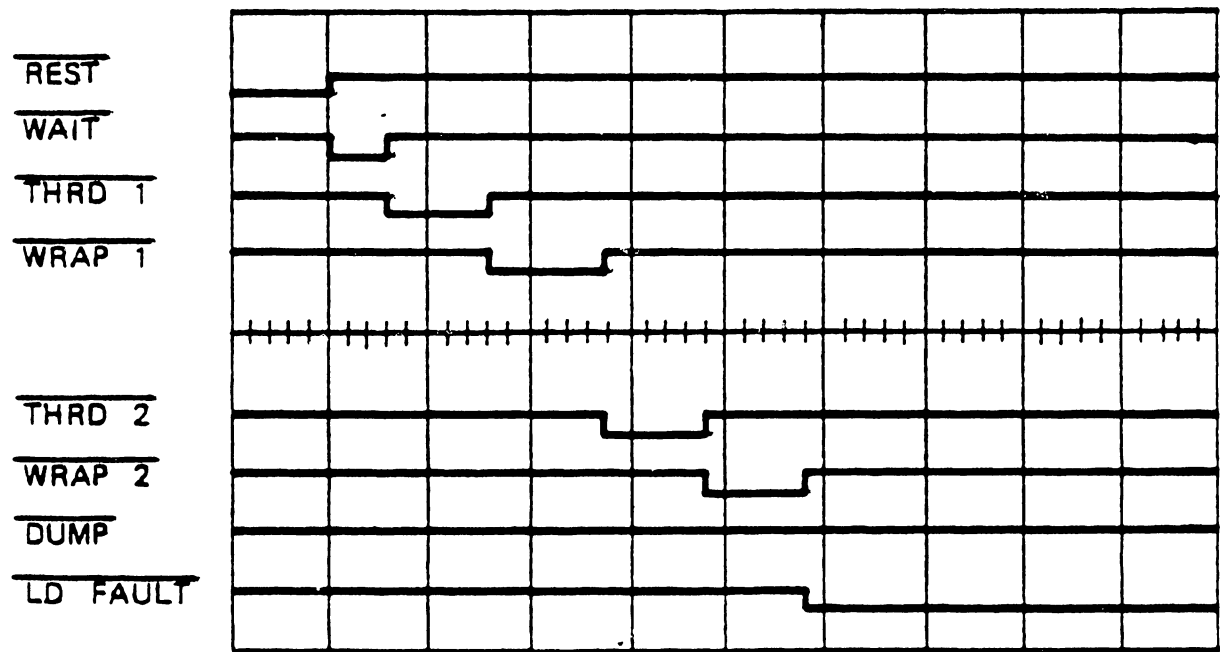

⑧ Cartridge present Failed two tries 5 sec/div

Figure 4-10. Autoload Timing Charts 4 of 4

4.7.3 Rewind or Unload

These functions are explained in the Rewind or Unload Flow Chart, Figure 4-11.

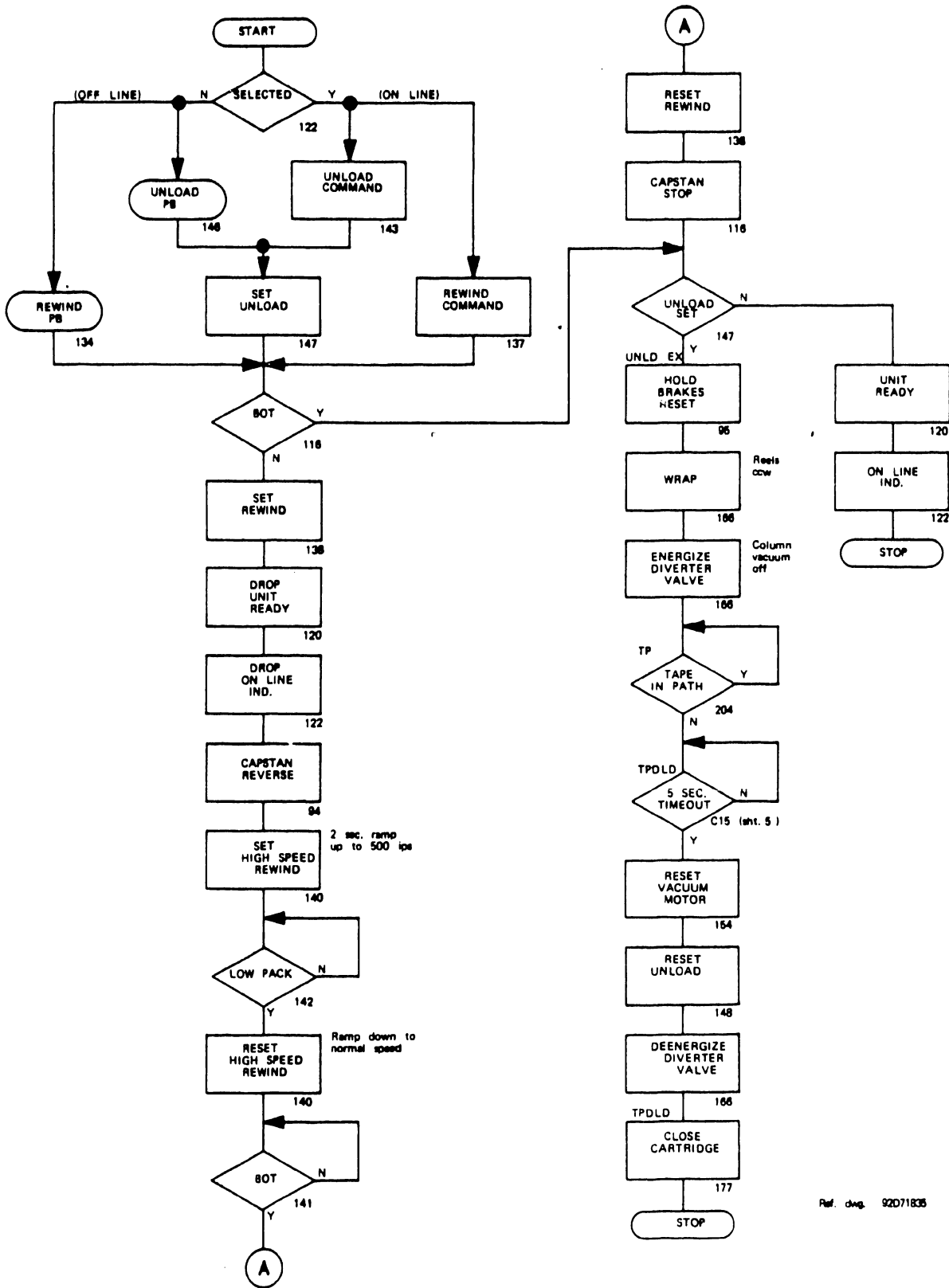

Ref. dwg. 92071835

Figure 4-11. Rewind or Unload Flow Chart

4.7.4 Tester

The tester built into the control logic gives the operator control over tape motion while the drive is off line. A pushbutton switch S3 on the board turns on the tester, the front panel RESET switch turns it off. Two independent multivibrators establish GO time and STOP time which can be varied readily over a considerable range. A flip-flop controls the direction of tape motion in conjunction with two toggle switches. There are six tester programs available, summarized below.

		S2		
		FWD (UP)	FWD/REV (MID)	REV (DOWN)
S1	GO (UP)	FWD	FWD, REV, etc. (no stop)	REV
	STOP (MID)	NO MOTION		
	GO / STOP (DOWN)	FWD, STOP, etc.	FWD, STOP, REV, STOP, etc.	REV, STOP, etc.

↑
times are variable

The tester components are shown on sheet 3 of the Control Logic Drawing. Operating instructions are in paragraph 5.3.

4.8 TELEX INTERFACE 92D72203

The Telex Interface transfers commands, status, and data on signal lines in a bus-tag configuration. A logic one (true) is high, a logic zero (false) is low. Levels are typically 2.4 and 0.2 volts.

4.8.1 Commands

The formatter sends a coded command in the form of an eight-bit byte on BUS OUT. The tape drive decodes this into discrete states which control machine functions. Figure 4-12 lists all the commands, their codes and conditions.

Command	Function	Conditions				Bus Out								
		Tag Out	Sense Status	Go Status	Write Status	P	0	1	2	3	4	5	6	7
CONTROL	SET WRITE	1	X	0	X	*	1	1	-	-	-	-	-	-
	RESET WRITE	1	X	0	X	*	1	0	-	-	-	-	-	
	SET BACKWARD	1	X	0	0	*	1	-	1	-	-	-	-	
	RESET BACKWARD	1	X	0	X	*	1	-	0	-	-	-	-	
	SET ALTERNATE DENSITY	1	X	0	X	*	1	-	-	1	-	-	-	
	SET GO	1	X	0	X	*	1	-	-	-	1	-	-	
	SET UNLOAD	1	X	0	0	*	1	-	-	-	-	1	-	
	SET REWIND	1	X	0	0	*	1	-	-	-	-	-	1	
	SET LOOP-WRITE-TO-READ	1	X	0	X	*	1	-	-	-	-	-	-	1
	RESET LOOP-WRITE-TO-READ	1	X	0	X	*	1	-	-	-	-	-	-	0
ADV SNS	ADVANCE SENSE COUNTER	1	1	0	X	0	0	0	0	0	0	0	0	
ERASE	ERASE TAPE WITHOUT WRITING	1	X	X	0	0	0	0	0	1	0	0	0	
SET NRZI	SET NRZI	1	X	0	X	0	0	0	1	1	0	0	0	
SENSE	SET SENSE STATUS	1	X	0	X	0	0	1	0	0	0	0	0	
ARA	INITIATE AUTO READ AMPLIFICATION	1	X	X	X	1	0	1	0	1	0	0	0	
SNS RESET	RESET SENSE ERROR INDICATORS	1	X	X	X	1	0	1	1	0	0	0	0	
STOP	RESET GO	1	X	1	X	X	X	X	X	X	X	X	X	
Write	WRITE DATA TO TAPE	0	0	1	1								DATA	

1 TRUE
 0 FALSE
 X DON'T CARE
 * ODD PARITY GENERATED
 - CONTROL FUNCTIONS WHICH CAN BE COMBINED

Figure 4-12. Telex Interface Commands

The flow chart, Figure 4-13, shows the sequence of events which begins with TAG OUT from the formatter. If a previous command has established GO status (tape is moving), this is a STOP command. Otherwise the logic decodes the command byte on BUS OUT. Bit 0 a one indicates a control type command. The byte, checked for parity and validity, registers in one or more control latches corresponding to the bits. Three latches can be either set or reset to give alternate functions: write/read, backward/forward, and loop-write-to-read. Write cannot combine with any reverse tape motion. Tape must be moving forward in write status in order to receive data. LWR ties the write data lines to BUS IN providing the formatter a check of the data interface.

If bit 0 is a zero a different type of command is on BUS OUT. A SENSE command requests current tape drive status information in the form of a sense byte. Each sense bit indicates a different condition. Sense status established by this command also enables the formatter to obtain four additional sense bytes by successive ADV SNS commands. A SNS RESET command clears the equipment failure indicators. ERASE status erases tape without writing. ARA initiates setting read gain for GCR.

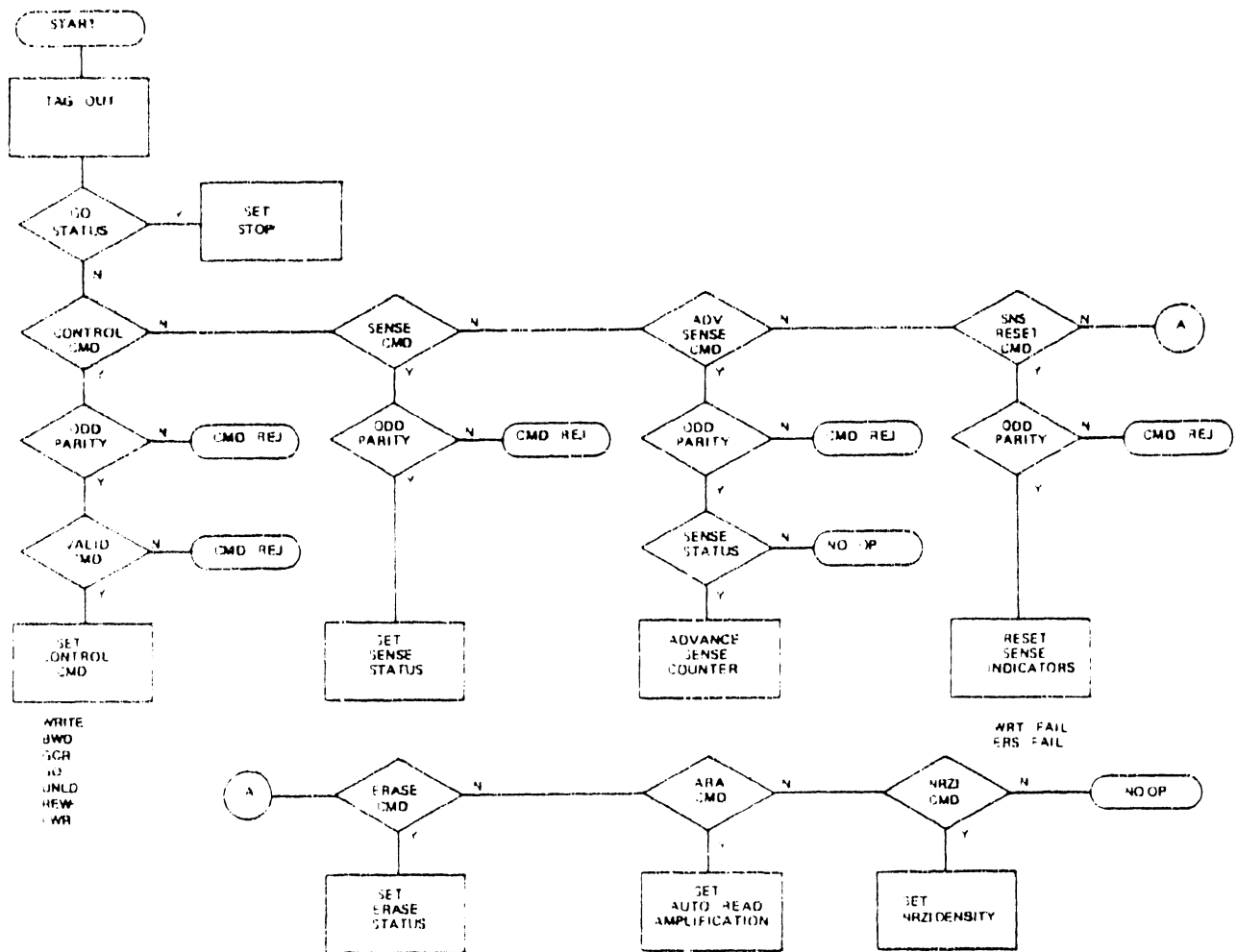

Figure 4-13. Command Decoding Flow Chart

4.8.2 Status Reporting

The current status of the tape drive collects in five sense bytes as shown in Figure 4-14. Some bits identify options installed, or model, others signal failure of a required condition. Sense byte 0 returns to the formatter at every TAG OUT. A SENSE command returns byte 0 too, but also conditions the logic to make the other four bytes available. Next, the formatter raises TAG OUT while holding BUS OUT false (ADV SNS command). Each TAG OUT fetches another sense byte. A control command resets sense status.

SENSE BYTE	BIT POSITION							
	0	1	2	3	4	5	6	7
0	LOAD POINT	NOT FILE PROTECTED	BACKWARD STATUS	WRITE STATUS	END OF TAPE	LO DENSITY	READY (ON LINE)	COMMAND REJECT
1	0	EQUIP FAIL	TU MODEL IDENTIFICATION BIT 0 BIT 1 BIT 2			6250 CAPABLE	LWR STATUS	0
2	IBG OVERFLOW	IBG COUNTER BIT 0 BIT 1 BIT 2 BIT 3 BIT 4 BIT 5 BIT 6						
3	LOAD CHECK	FORCE READ DENSITY	1 (DUAL DENS)	0	ERASE FAIL	0	LOOPOUT	0
4	ALT DFN REQUEST	1 (TRI DENSITY)	10in HEAD	0	WRITE CURRENT FAIL	ERASE STATUS	SAGC CHECK	0

* TU MODEL IDENTIFICATION

Bit 0 1 2	TU MODEL	TAPE SPEED
0 1 0	6253-33	45
0 1 1	6253-44	75
1 0 1	6253-66	125

Figure 4-14. Sense Bytes

4.8.3 Data Transfer

NRZI: Each BUS OUT line starts at logical zero (erase polarity), then reverses for each logical one data bit. No change represents a logical zero data bit. Any logical one to zero transition on BUS IN represents a logical one bit read from tape. No transition is a zero bit.

PE: A logical one to zero transition on BUS OUT is a logical one data bit. A zero to one transition is a zero data bit. Successive one or zero data bits have a phase bit or transition inserted midway between the data bits. Data is the same on BUS IN during a read.

GCR: A logical one data bit is a transition on BUS OUT or BUS IN, and a logical zero is no transition. Maximum transitions occur for all ones at 9042 flux reversals per inch.

4.8.4 Tape Drive inputs from Formatter

BUS OUT P, 0-7 are nine lines which transmit commands or data. When TAG OUT is true the BUS OUT lines contain a command to be executed. The tape drive checks for odd parity of the command byte. When TAG OUT is false and a previous write and go command have been issued, the BUS OUT lines contain data to be written on tape. In data mode the tape drive does not check parity. In addition, during a PE or GCR read operation the BUS OUT lines carry amplitude sense information to the formatter. Note that these lines are bidirectional. When the signal level of a tape track drops below the minimum threshold level for three consecutive bytes, an amplitude sense error warns the formatter that data from that particular track is deteriorating. This gives sufficient time to initiate correction procedures before losing any information.

OP OUT (Operational Out) allows the tape drive to communicate with the formatter. When false, OP OUT serves as a general reset.

THLD OUT (Threshold Out) allows the formatter to keep the BUS OUT lines enabled during a read operation while checking for the interblock gap (IBG). This is to insure that a crease in the tape is not mistaken for the IBG. When the AMP SNS levels drop, indicating no more data is being read, the formatter issues a stop command by raising TAG OUT. It also raises THLD OUT to keep BUS OUT active. If more data is not detected before the capstan speed decreases to seven percent of normal, the formatter logic assumes it has detected a normal IBG at the end of a data block. But if data activity does return, a crease evidently caused the false indication of a gap. In this case the formatter raises another go command and continues to search for the gap.

TAG OUT indicates that the BUS OUT lines carry a command to be executed by the tape drive. When the drive is executing a previously issued go command, TAG OUT is a stop command.

4.8.5 Tape Drive outputs to Formatter

BUS IN P, 0-7 are nine lines which transmit status or data. When TAG IN is true the BUS IN lines carry tape drive status information with odd parity. When TAG IN is false the BUS IN lines carry data read from tape. Data is in one of three forms: NRZI, PE, or GCR.

In NRZI a binary one is any transition. In PE and GCR data is a differentiated and squared version of the signal from tape.

TRWNR is true when the drive is rewinding or not ready. The line remains true until the drive is ready. TRWNR is also active when a go backward operation reaches load point. A stop command clears this condition.

TAG IN rises in response to TAG OUT from the formatter and indicates that a tape drive status byte is present on BUS IN. TAG IN falls when TAG OUT falls.

TACH IN supplies tachometer pulses to the formatter. These pulses indicate tape speed and distance at the rate of one pulse per .00471 inch of tape travel.

INTR (Interrupt) transfers and end-of-tape interrupt to the formatter.

4.9 DATA ELECTRONICS

The 6253 Tape Drive handles digital data in three recording modes. The 6253 operates in either 800 bpi NRZi (Non-Return to Zero, switch on 1's), 1600 PE (Phase Encoded) mode, or 6250 GCR (Group-Coded Recording).

4.9.1 NRZI/PE/GCR Write

Figure 4-15 simplifies the write electronics on logic diagram 92D72205 and refers to track 1 details as a typical data channel. Data to be written on tape arrives at the multiplexer from the formatter and I/O board. The multiplexer selects this write data (WT1) or an off-line test frequency from the built-in tester

A one-shot multivibrator provides a compensation pulse of adjustable width and adds it to the beginning of each data bit. This step of higher amplitude gives a more symmetrical written pattern on tape. It combines with the data to produce high current, double the normal current value, at the head. The write current driver converts logic level data into current changes through the write head. An adjustable write current regulator supplies operating voltage for each mode to the driver. NRZI mode saturates the regulator. The write power switch enables each head center tap through a 0.125A fusible resistor. An LED indicates write power on.

In PE or GCR mode a pair of one-shots monitor data activity on the identification tracks 4 and 6. They switch the write drivers to high current so the write head aids the erase head in creating a clean gap where no data is written. NRZI mode holds these one-shots clear to generate high current.

A separate driver supplies the dc erase head, and an LED indicates erase current on.

A degauss timer feeds a 4KHz oscillator output onto the data path for a few milliseconds at the end of write status. As the output from the write current regulator drops, the result is a decaying alternating current which degausses the head.

The built-in tester consists of an oscillator which provides a local substitute for write data. While tape moves forward under local control of the tape motion exerciser on the Control Logic board (TESTER ENABLED), a five section DIP switch S1 selects one of five data rates to be written. Switch 1 turns the generator on and off. Switches 2-5 select a particular, nominal data rate useful for PE and GCR modes. Switch 1 alone generates 800 fci for NRZI mode. Paragraph 5.3 gives operating instructions for the tester.

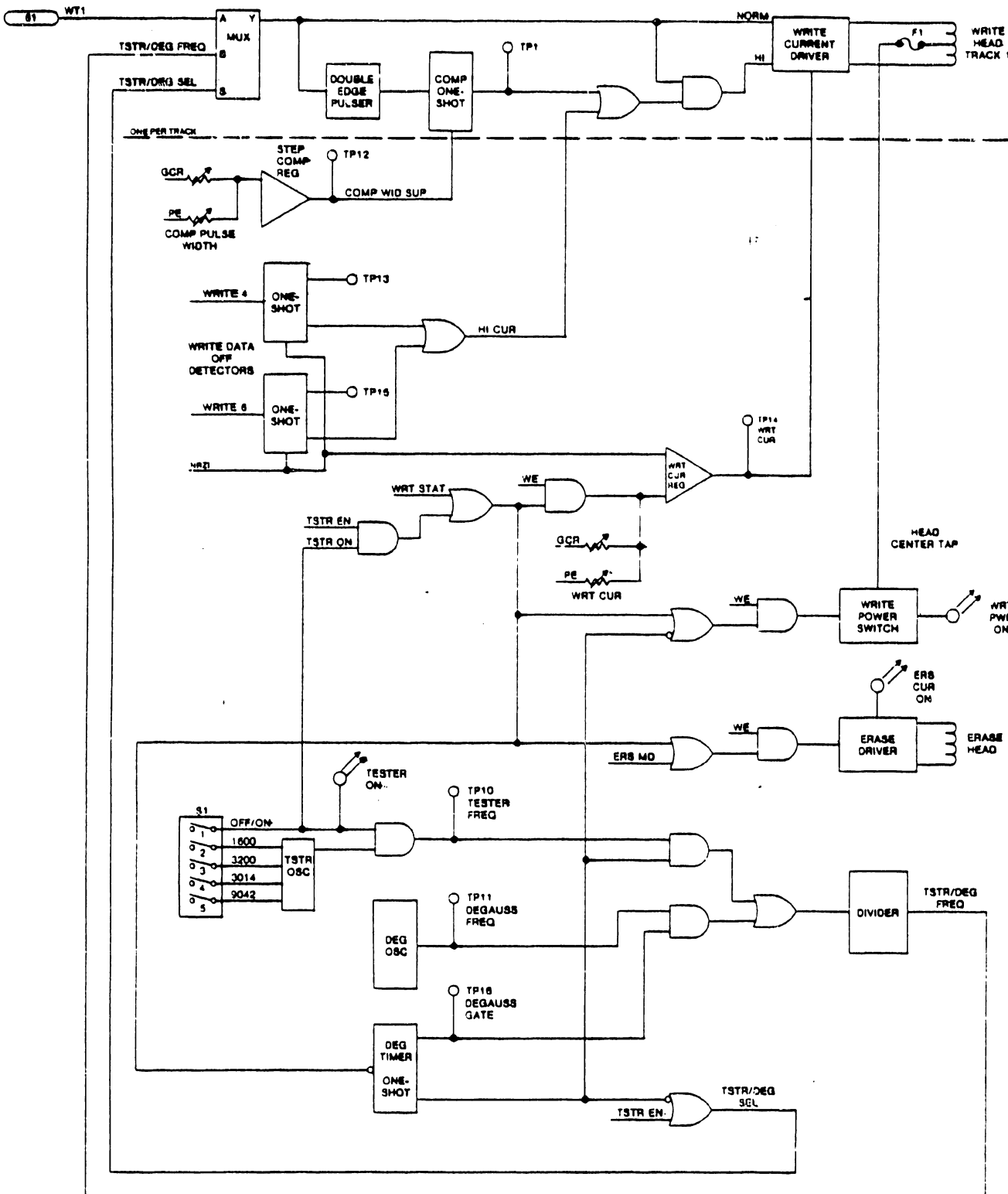

REFERENCE DRAWING 72206

Figure 4-15 6253 Write Electronics Simplified Logic

4.9.2 FE/GCR Read

Refer to Figure 4-16 and logic diagrams 92D72201 and 92D71830. The read head picks up data from tape in all three modes and applies it to a differential preamplifier U7. This increases the voltage level by 100X. The differential signal (PREAMP 1) jumpers to the next board for use in NRZI mode. PE and GCR signals encounter an active differentiator Q1, Q2, Q37; an automatic step attenuator for GCR controlled by analog switches U1, U4; and an adjustable gain pot for PE. An amplifier Q4, Q3 boosts the signal and drives a low pass RLC filter optimized for GCR. The signal then goes to three components: a test point for observation of the analog signal, the Zero Crossing Detector U2 for conversion to digital logic levels, and the amplitude sensor detector U6 for level detection. During a read, logic gates apply the digital data to a tri-state driver and out to the formatter via the I/O board.

The Amplitude Sense Detector compares the analog signal level to a fixed threshold voltage and indicates when the data level exceeds the threshold (OVR TH 1). The four fixed threshold voltages from generator U56-U58 depend on the mode (GCR/not GCR) and whether reading or writing (read after write). An Amplitude Sense Delay circuit provides gating and other functions by establishing AMP SNS 1 after OVR TH 1 has been active for some period (a few data cells). Conversely, the delay circuit drops AMP SNS 1 after a lesser period of data amplitude below threshold. During write (read after write) the logic allows data to the bus driver for each track only if AMP SNS has been established for that track.

GCR mode offers automatic gain setting from the ARA Burst on the tape. The ARA Burst contains all ones in all tracks for at least 5.2 inches and follows the GCR ID Burst. The Gain Bit Latches (U5) for each track reset while the drive is in PE mode at load point (RST GAIN). After the formatter identifies a GCR tape it issues the INIT ARA command (Initiate Auto Read Amplification). This initializes the automatic gain logic: clears the Gain Set Latch (O2, O3 for track 1), turns on the Oscillator Control Latch O7, O10, starts the AGC Step Oscillator 16, and clears the Step Counter 19. While reading the ARA Burst the logic steps the gain setting of each track as necessary to attain a standard level of 1 volt at TP1 (3 volts into the data detector).

The Step Counter at zero addresses the Attenuator ROM which establishes a starting gain bit pattern. The Gain Bit Latches for each track store this pattern to apply maximum attenuation to the ARA Burst signal from the head. While setting gain the Amplitude Sense Detector compares the level from the ARA Burst and attenuators to an AGC threshold level set at 0.925 volts (referred to TP1). The AGC Step Oscillator generates an output step once each quarter inch of the ARA Burst that passes. If AMP SNS 1 is not established with the initial, maximum attenuator setting (not likely to be) the step oscillator clocks the counter, addressing the ROM for a new gain bit pattern, and triggers the Track Clock Generator to store this pattern in the Gain Bit Latches (CLK TK 1). At each new setting the level increases 15% over the previous one. Until AMP SNS 1 is established this cycle continues, the level increasing in 15% steps every quarter inch of the ARA Burst. When AMP SNS 1 rises it sets the Gain Set Latch for track 1 and locks in the current attenuator setting (no further CLK TK 1). Other tracks may continue their search for gain set condition. As enough tracks reach gain set the Zone Logic turns off the Oscillator Control Latch and ends the stepping. If gain set fails to occur within 15 steps for a Read command (13 for Write), gate 25 declares Set Automatic Gain Check (SAGC) to the formatter and shuts off the stepping logic. Now, in preparation for reading the data blocks, the Threshold Generator switches to a lower level based on the variables explained above.

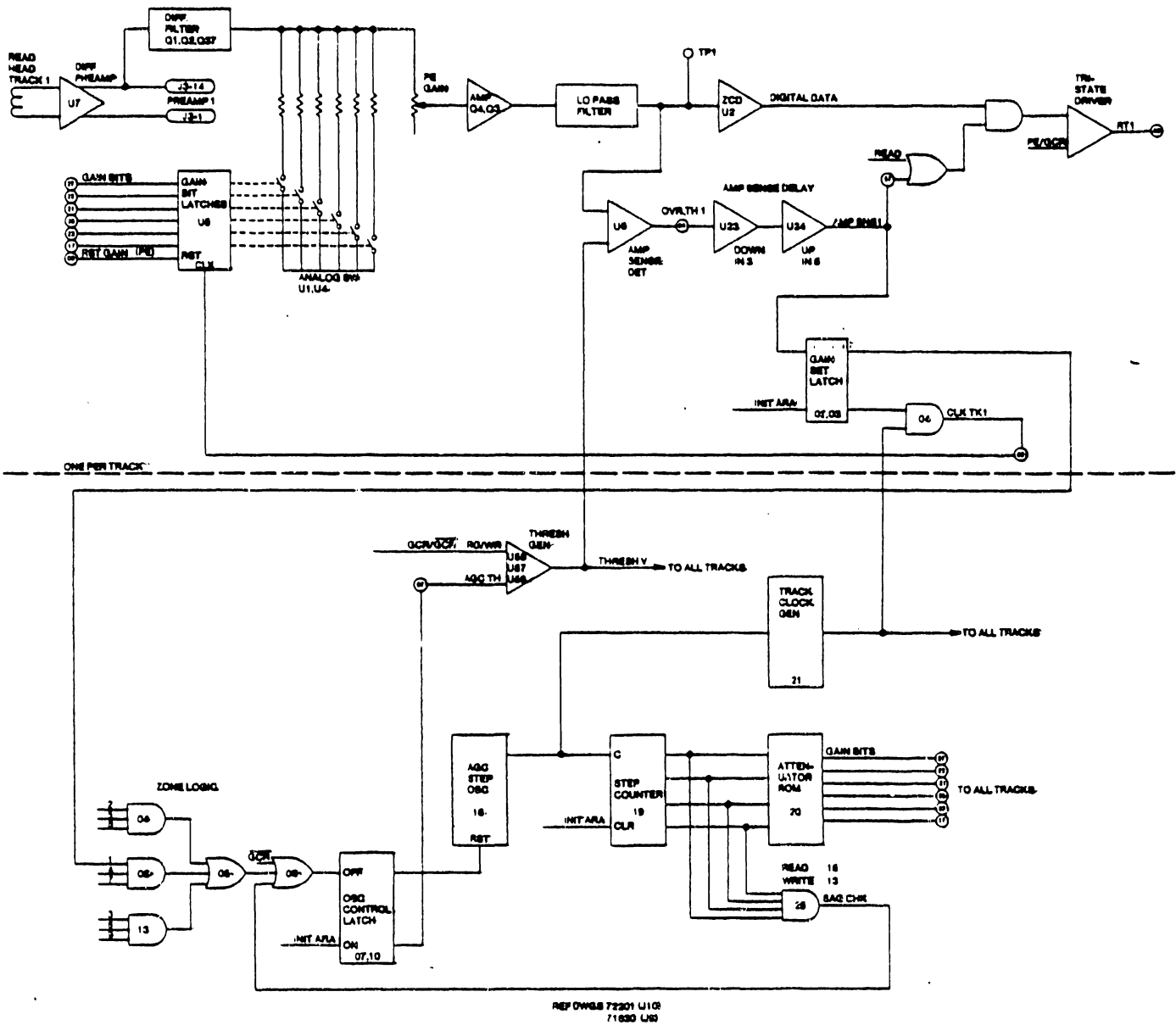
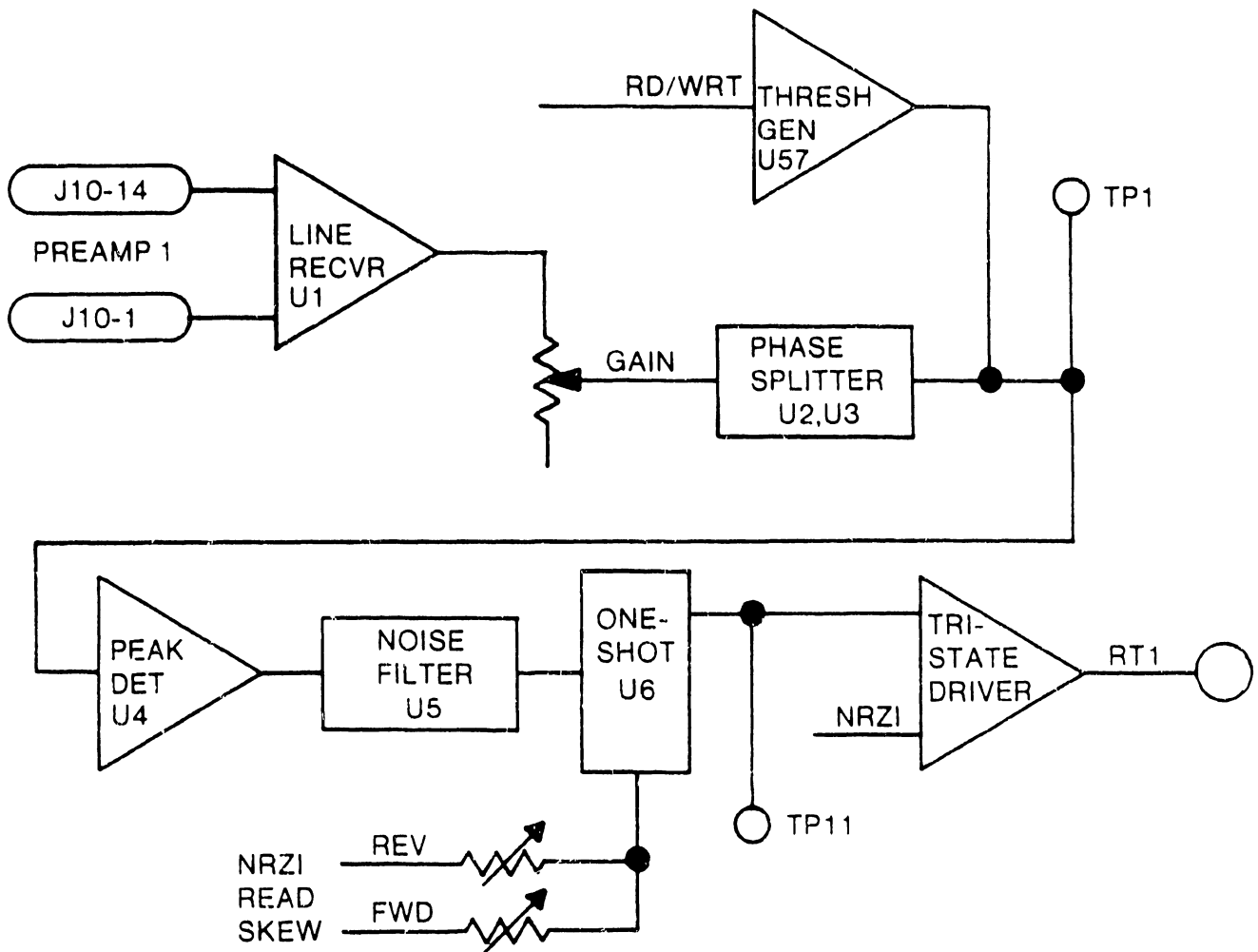

Figure 4-16. PE/GCR Read Simplified Logic

4.9.3 NRZI Read

Figure 4-17 simplifies the NRZI Read electronics for track 1 on logic diagram 92D72202. Read data from the head flows through a preamplifier on the PE/GCR Read board and jumpers to this board. It enters the line receiver U1 as a differential signal (PREAMP 1) and exits as a single ended signal applied to the gain control. A phase splitter converts the data to two equal and opposite signals. A pair of diodes rectifies the signals at TP1. The Threshold Generator adds a fixed threshold voltage dependent on read or write mode. Element U4 is a peak detector; U5 a noise filter. One-shot delay U6 provides read data skew adjustment in both directions of tape motion. In NRZI mode the tri-state driver accepts the aligned data. The driver output RT1 is a bus common to the PE/GCR read output. The tri-state drivers of both boards insure that only one board at a time feeds data onto the bus.



REF DWG 72202

Figure 4-17 6253 NRZI Read Simplified Logic

4.10 MANUAL DENSITY SELECTION AND FORCED READ

4.10.1 Computer Adapter Interface

Density Select bits 0 and 1 (DS0 and DS1) are signals generated by the Adapter in the formatter to command the formatter to write in a density selected by the system or to relinquish write density selection to the tape unit operator. The Density Select bits are decoded by the formatter according to the following table:

DS0	DS1	Function Decode
0	0	Write PE
0	1	Write NRZI
1	0	Write GCR
1	1	Write in Manually Selected Density

4.10.2 Tape Unit Interface

The following tape unit sense bits provide information to the formatter necessary for density selection:

Sense Byte	Bit	Function
0	0	Load Point
0	5	* Low Density Indicates PE when in PE/GCR mode or NRZI when in NRZI/PE mode.
1	5	* 6250 Capable Indicates when high that tape unit is in PE/GCR mode or when low, NRZI/PE mode.
4	0	Alternate Density Request Indicates that either GCR or NRZI is requested.
4	1	Triple Density Indicates that tape unit is triple density capable.

*These sense bits provide actual tape unit status when unit is online and in midtape. They provide manually selected status when offline or when online at loadpoint.

4.10.3 Tape Unit Operator Control Panel

There are three density indicators (NRZI, PE, and GCR) and one DENSITY selector switch. If the Manual Density Select feature is installed then the operation is as follows:

- Offline. Repeated operation of the DENSITY switch selects NRZI, PE, and GCR in rotation.
- Online at Loadpoint. Density indicators indicate density manually selected when tape drive was offline. DENSITY switch is inhibited.
- Online in midtape. Density indicators indicate true operational density. DENSITY switch is inhibited.

If the Manual Density Select feature is not installed then the operation is as follows:

- Offline. Repeated Operation of the Density Switch selects NRZI, PE & GCR in rotation.
- Online at Loadpoint. Density switch is inhibited.
- Online in Midtape. Density switch is inhibited.

4.10.4 Subsystem Write Operations

Write operations are performed in the density commanded by the DS0 and DS1 signals at the Computer Adapter Interface. When these two signals are in the 11 configuration the Computer Adapter is relinquishing density control to the tape unit. This can have useful results only if the Manual Density Select feature is activated in the tape unit. In this case the operator can select the desired density on the tape unit while the tape unit is offline. Write operations at loadpoint will be made in the selected density. Note that the formatter will never make density changes in midtape.

4.10.5 Subsystem Read Operations

Normally, read operations are performed in the density indicated by reading the ID burst information written in the area of the BOT marker.

The read density may be selected by the operator if the Manual Density Select feature is installed and the Force Read status is switched on. Density changes are effected only at loadpoint in read operations as is the case in write operations. If the operator selects the wrong density then read errors are to be expected.

The operation of the DENSITY push button and the density indicators is summarized in the table below.

DENSITY INDICATOR OPERATION

<u>Tape Unit State</u>	<u>MANUAL Density Select</u>	<u>Automatic Density Select</u>
Offline	as manually selected	as manually selected
Online at Load Point	as manually selected	PE
Online in mid-tape	actual density in use	actual density in use

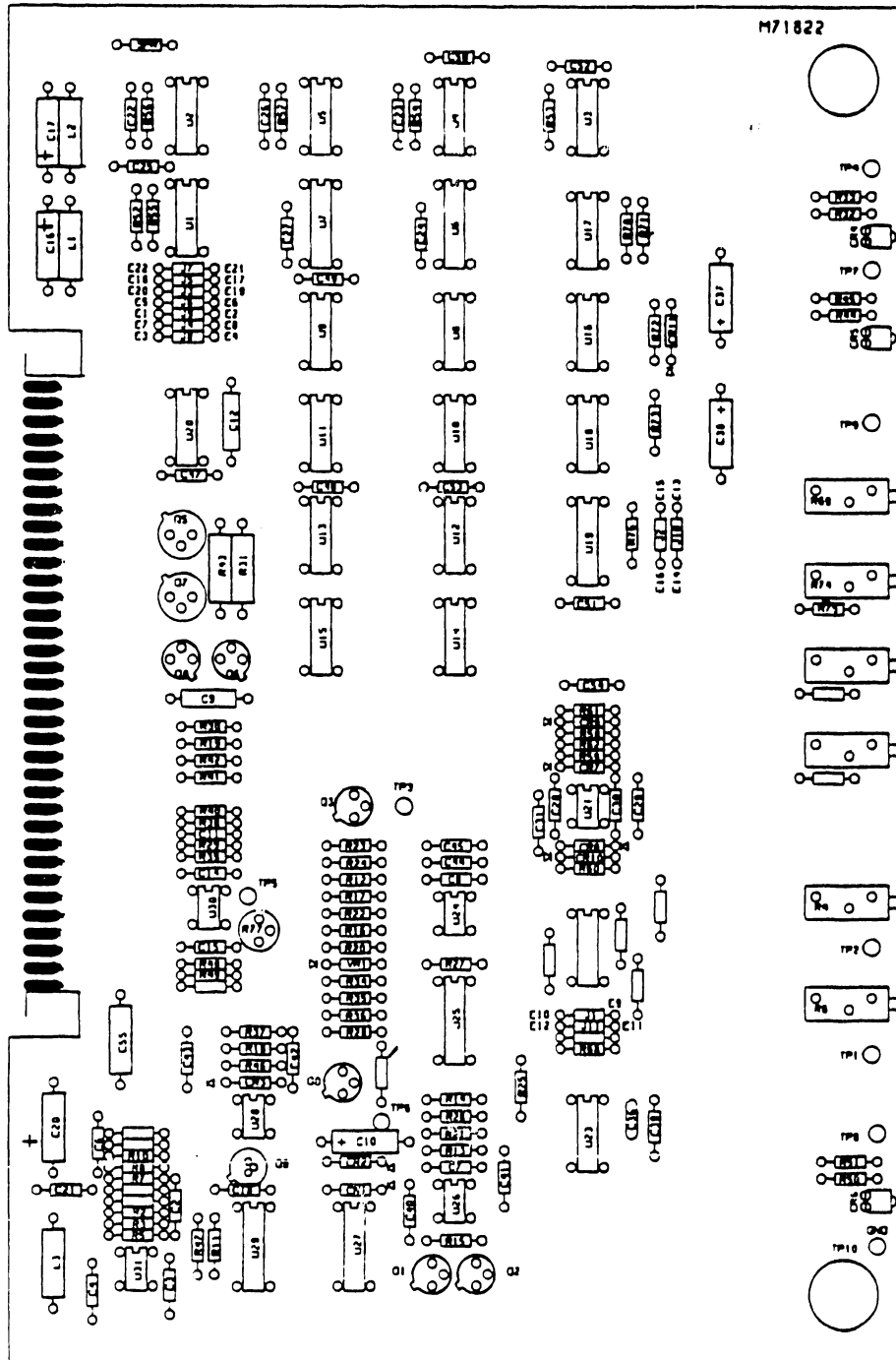

91D71822 Capstan Preamp

REF NUMBER	SCH REF NUMBER	NOMENCLATURE	REF PART NUMBER	QTY
		PCB Assembly, Capstan Preamp	91D71822(P)	
2		Transistor Pad, TO-5	A42X00935-01	2
3		Transistor Pad, TO-18	A42X00936-01	5
4	Q1,6,9	Transistor, 2N2222	A42X00822-01	3
5	Q2,4	Transistor, 2N2907	A42X00788-01	2
6	Q5	Transistor, 2N5320	A42X01071-01	1
7	Q7	Transistor, 2N5322	A42X00772-01	1
8	Q3	Transistor, 2N5640	A42X01555-01	1
9	Q8	Transistor, MPS 404A	A42X01556-01	1
10	CR1-3,7-11	Diode, 1N914	A42X00664-01	8
11	VR1	Diode, 1N821A	A42X01019-01	1
12	CR4-6	Diode, LED PCH-125R	A42X01486-01	3
13	U21,24,28	I.C. MC 1458	A42X01144-01	3
14	U25,29	I.C. HI-201-5	A42X01487-01	2
15	U26,30,31	I.C. MC1741	A42X01545-01	3
16	U1	I.C. 74LS14	A42X01493-01	1
18	U27	Speed Module (See Top Assy)	91D22268	REF
19	U16,20	I.C. 74LS132	A42X01495-01	2
20	U6,7,19	I.C. 74LS161	A42X01460-01	3
21	U2,3,14,15,18	I.C. 74LS74	A42X01452-01	5
22	U12,13	I.C. 74LS02	A42X01447-01	2
23	U8,9	I.C. 74LS32	A42X01485-01	2
24	U10,11,17	I.C. 74LS08	A42X01395-01	3
25	U4,5	I.C. 74LS00	A42X01445-01	2
26	L1,2,3	Inductor, 100 uH, 10%	A31X00338-01	3
27	C55	Capacitor 0.22uf, 50V, 10%	A27X00120-01	1
28	C7,28,54	Capacitor, .0022 uf, 100V, 10%	A27X00140-01	3
30	C23,26	Capacitor, .0047 uf, 50V, 10%	A27X00198-01	2
31	C24,27	Capacitor, .01 uf, 100V, 10%	A27X00116-01	2
32	C22,25	Capacitor, .018 uf, 50V, 10%	A27X00197-01	2
33	C3,4,8,14,15,18,21,30,31,39,40-45,47-53	Capacitor, .1 uf, 50V, 10%	A27X00176-01	23
34	C9,12	Capacitor, .33 uf, 50V, 10%	A27X00175-01	2
35	C16,17,20	Capacitor, 10 uf, 20V, 10%	A24X00098-01	3
36	C10,37,38	Capacitor, 15 uf, 20V, 10%	A24X00048-01	3
37	R24	Resistor, 1.78K, 1/8W, 1%	A13X02231-01	1
38	R3,8	Resistor, 2.94K, 1/8W, 1%	A13X01730-01	2
39	R5,7	Resistor, 5.11K, 1/8W, 1%	A13X01896-01	2
40	R23	Resistor, 6.19K, 1/8W, 1%	A13X02389-01	1
42	R17,22	Resistor, 10K, 1/8W, 1%	A13X00302-01	2
43	R58,59,61,62,81	Resistor, 15K, 1/8W, 1%	A13X01878-01	5
44	R26	Resistor, 19.6K, 1/8W, 1%	A13X02390-01	1
45	R13,21	Resistor, 20K, 1/8W, 1%	A13X01881-01	2

		PCB Assembly, Capstan Preamp (Cont'd)	91D71822	
46	R20	Resistor, 237 ohm, 1/8W, 1%	A13X02388-01	1
47	R29	Resistor, 10 ohm, 1/4W, 5%	A13X01864-01	1
48	R31,43	Resistor, 33 ohm, 3W, 5%	A13X02387-01	2
49	R41	Resistor, 100 ohm, 1/4W, 5%	A13X01868-01	1
50	R28,54,57	Resistor, 470 ohm, 1/4W, 5%	A13X01814-01	3
52	R19,30,33,42, 45,50-53,55, 56,68,76	Resistor, 1K, 1/4W, 5%	A13X01277-01	13
53	R16	Resistor, 1.2K, 1/4W, 5%	A13X01833-01	1
54	R32,39,44,72	Resistor, 2K, 1/4W, 5%	A13X01063-01	4
55	R47	Resistor, 2.4K, 1/4W, 5%	A13X01800-01	1
56	R14,15	Resistor, 4.7K, 1/4W, 5%	A13X01860-01	2
57	R60	Resistor, 7.5K, 1/4W, 5%	A13X02023-01	1
58	R18	Resistor, 39K, 1/4W, 5%	A13X01935-01	1
59	R46	Resistor, 30K, 1/4W, 5%	A13X01976-01	1
61	R75	Resistor, 5.1K, 1/4W, 5%	A13X01909-01	1
62	R77	Potentiometer, 10K, 1/2W, 10%	A14X00462-01	1
63	R27,34,36	Resistor, 100K, 1/4W, 5%	A13X01977-01	3
64	R35	Resistor, 200K, 1/4W, 5%	A13X02055-01	1
65	R4	Potentiometer, 10K, 3/4W, 5%	A14X00490-01	1
68	R74	Potentiometer, 2K, 3/4W, 5%	A14X00498-01	1
69	R69	Potentiometer, 20K, 3/4W, 10%	A14X00489-01	1
71	U23	I.C. AD 537	A42X01554-01	1
72	C29	Capacitor, .001 uf, 100V, 10%	A27X00115-01	1
73	C36	Capacitor, .001 uf, 100V, 1%	A21X00221-01	1
74	J4	Jumper Component (Dual Speed)	A51X00908-01	1
74	J1,2,3	Jumper Component	A51X00908-01	3
75	R11,12,25, 37,70,71,73	Resistor, 10K, 1/4W, 5%	A13X01065-01	7
77	XU27	Socket, 16 Pin Dip I.C.	A42X01161-01	1
78	R6	Potentiometer, 50K, 3/4W, 10% (Dual Speed)	A14X00501-01	1
80	TP1-10	Terminal, Subminiature	A59X00079-01	10
81	R38	Resistor, 23.2K, 1/8W, 1%	A13X02469-01	1
82	C11	Capacitor, .0015uf, 100V, 10%	A27X00138-01	1
83	L4	Inductor, 5.6mh, 10%	A13X00313-01	1
84	R78,79	Resistor, 51 ohms, 1/4W, 5%	A13X01980-01	2
85	R80	Resistor, 1.62K, 1/4W, 1%	A13X01288-01	1
86	C56	Capacitor, 0.15uf, 50V, 10%	A27X00216-01	1

B71827

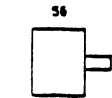
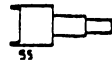
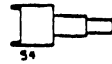
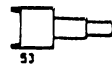
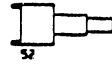
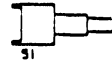

91D71827 Switch Board

REF NUMBER	SCH REF NUMBER	NOMENCLATURE	REF PART NUMBER	QTY
		PWB Assembly, Switch Board	91D71827(E)	
2	S1-5	Switch, Toggle, 3 Position	A43X01287-01	5
3	S6	Switch, Push Button	A43X01289-01	1
4	CR1	Diode, HP 2800	A42X00915-01	1
5	R1-7	Resistor, 1.5K, 1/4W, 5%	A13X01797-01	7
11		Terminal, Subminiature	A59X00079-01	8



071830

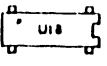
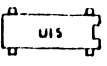
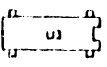
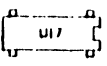
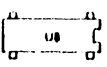
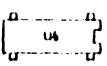
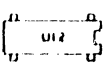
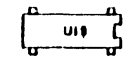
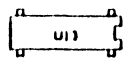
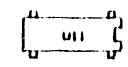
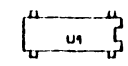
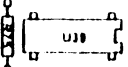
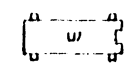
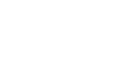
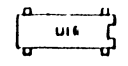
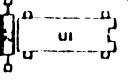
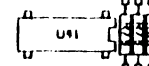
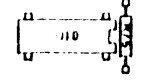
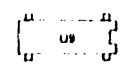
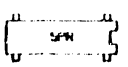

91D71830 AGC & AMP Sense

TP1

GND

REF NUMBER	SCH REF NUMBER	NOMENCLATURE	REF PART NUMBER	QTY
		PWB Assembly AGC & AMP Sense	91D71830(H)	
2	U41	I.C., 7406	A42X01007-01	1
3	U1,16	I.C., 74LS04	A42X01396-01	2
4	U2,5	I.C., 74C04	A42X01567-01	2
5	U3,4,6,7, 8,11,12, 17,19,39	I.C., 74LS00	A42X01445-01	10
6	U10	I.C., 74LS11	A42X01449-01	1
7	U13	I.C., Prom	A42A20214-01	1
8	U14	I.C., 555 Timer	A42X01306-01	1
9	U15	I.C., 74LS93	A42X01509-01	1
10	U18	I.C., 74H21	A42X00978-01	1
11	U20	I.C., 96L02	A42X01494-01	1
12	U21-U38	I.C., 311 Comparator	A42X01342-01	18
13	CR1-CR27,CR1- 45(-5&-6)	Diode IN914	A42X00664-01	27
14	U9	I.C., 74LS10	A42X01448-01	1
15	Q1	Transistor, 2N2907	A42X00788-01	1
16	R1,2,3,4, 11,15,16, 18,20	Resistor, 10K, 1/4W, 5%	A13X01065-01	9
17	R5,6,7,8,9, 10,14,19,23, 28,31,32,35, 40,43,44,47, 52,55,56,59, 64,67,68,71, 74,75,76,77, 79,80	Resistor, 2.2K, 1/4W, 5%	A13X01343-01	31
18	R12	Resistor, 49.9K, 1/8W, 1%	A13X02104-01	1
19	R12(-2&-6); R22,27,34,39, 46,51,58,63, 70(-03 only)	Resistor, 28.7K, 1/8W, 1%	A13X02147-01	1
20	R12	Resistor, 20.0K, 1/8W, 1%	A13X01881-01	1
21	R12	Resistor, 15.0K, 1/8W, 1%	A13X01878-01	1
24	R13	Resistor, 2.67K, 1/8W, 1%	A13X02374-01	1
25	R17	Resistor, 22K, 1/4W, 5%	A13X01866-01	1
26	R21,26,33, 38,45,50,57, 62,69(-01&-05) R22,27,34,39, 46,51,58,63, 70(-2 &-6)	Resistor, 37.4K, 1/8W, 1%	A13X02456-01	9
27	R21,26,33, 38,45,50,57, 62,69(-2&-6) R22, 27, 34, 39, 46,51,58,63, 70(-4 only)	Resistor, 22.6K, 1/8W, 1%	A13X02495-01	9

28	R21,26,33,38, 45,50,57,62, 69	PWB Assembly AGC & AMP Sense (Cont'd) Resistor, 16.9K, 1/8W, 1%	91D71830(H) A13X02494-01	9
29	R21,26,33, 38,45,50,57, 62,69	Resistor, 13.7K, 1/8W, 1%	A13X02493-01	9
32	R22,27,34, 39,46,51,58, 63,70	Resistor, 64.9K, 1/8W, 1%	A13X02219-01	9
33	R24,25,29, 30,36,37,41, 42,48,49,53, 54,60,61,65, 66,72,73,78	Resistor, 510 ohm, 1/4W, 5%	A13X01811-01	19
34	R81,83,85, 87,89,91,93, 95,97(-5 only) R82,84,86, 88,90,92, 94,96,98 (-6 only)	Resistor, 53.6K, 1/8W, 1%	A13X02479-01	9
35	R81,83,85, 87,89,91,93, 95,97	Resistor, 32.4K, 1/8W, 1%	A13X01884-01	9
36	R82,84,86, 88,90,92,94, 96,98	Resistor, 82.5K, 1/8W, 1%	A13X02200-01	9
40	C1,2,3,4 5,6,10,11,12	Capacitor, .0056uf, 50V, 10%	A27X00215-01	9
41	C7	Capacitor, 0.15uf, 50V, 10%	A27X00216-01	1
42	C8	Capacitor, .01uf, 100V, 10%	A27X00116-01	1
43	C9	Capacitor, 1000pf, 100V, 10%	A27X00115-01	1
44	C13-C30	Capacitor, .0022uf, 100V, 10%	A27X00140-01	18
45	C31,35,39	Capacitor, 15uf, 20V, 10%	A24X00048-01	3
46	C32-34,36-38, C40-61	Capacitor, 0.1uf, 50V, 20%	A27X00176-01	28
47	J2	Jumper Component	A51X00908-01	1
48	XQ1	Pad, Transistor	A42X00936-01	1
49	L1,2,3	Inductor, 100uh, 10%	A31X00338-01	3
50	XU13,XU40	Socket, 16 Pin	A42X01161-01	2
52	TP1, TP GRD	Terminal, Turret	A59X00015-01	2
54	R99	Resistor, 1K, 1/4W, 5%	A13X01277-01	1

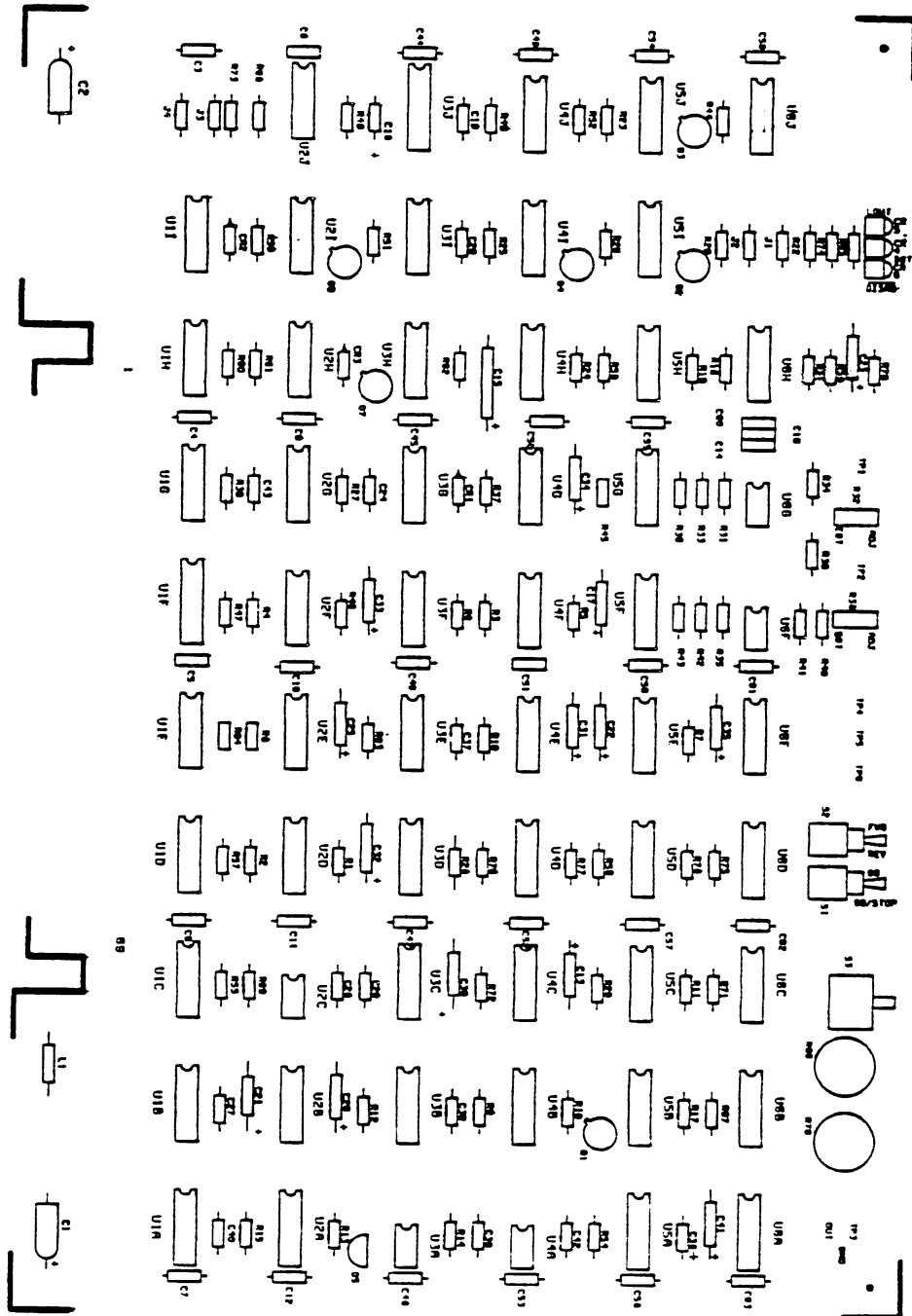

91D71835 Control Logic

REF NUMBER	SCH REF NUMBER	NOMENCLATURE	REF PART NUMBER	QTY
2	U1B,2I,3C, 3D,3F,3I, 4E,4H,5G, 6A	PWB Assembly, Control Logic I.C., 74LS00	91D71835(F) A42X01445-01	10
3	U1A,1H,2G, 3E,4F,4G, 5C,5D,5H, 6D	I.C., 74LS02	A42X01447-01	10
4	U1E,2D,3H	I.C., 74LS04	A42X01396-01	3
5	U6E	I.C., 74LS05	A42X01536-01	1
6	U1C,1I,2F, 2J,6J	I.C., 74LS08	A42X01395-01	5
7	U2B,3B,5F	I.C., 74LS10	A42X01448-01	3
8	U2A,3G,4D, 5E	I.C., 74LS14	A42X01493-01	4
9	U1G,2E	I.C., 7416	A42X00990-01	2
10	U6B,6C,6H	I.C., 74LS27	A42X01451-01	3
11	U4C,5I,5J	I.C., 74LS32	A42X01485-01	3
12	U4B	I.C., 74LS42	A42X01499-01	1
13	U1D,2H,4I, 4J,5A,5B	I.C., 74LS74	A42X01452-01	6
14	U2C,3A,4A	I.C., NE 555	A42X01306-01	3
15	U3J	I.C., 96L02	A42X01494-01	1
16	U6F,6G	I.C., LM311	A42X01342-01	2
17	U1F	I.C., ULN 2003	A42X01538-01	1
18	Q1,6,7	Transistor, 2N2222	A42X00822-01	3
19	Q2,3,4	Transistor, 2N2907	A42X00788-01	3
20	Q5	Transistor, 2N6427	A42X01544-01	1
21	CR2,3	Diode, 1N 914	A42X00664-01	2
22	CR4,5,6	LED, PCH 125	A42X01486-01	3
23	R2,4,6,8, 16,28,46, 55,57,59	Resistor, 68 ohm, 1/4W, 5%	A13X01836-01	10
24	R72	Resistor, 100 ohm, 1/4W, 5%	A13X01868-01	1
25	R67,71	Resistor, 200 ohm, 1/4W, 5%	A13X01862-01	2
26	R11,34,41, 64	Resistor, 430 ohm, 1/4W, 5%	A13X01805-01	4
27	R9,10,13, 14,15,17, 30,33,36, 39,43,44,47, 52,65,68,73, 74,80	Resistor, 1K, 1/4W, 5%	A13X01277-01	19
28	R37	Resistor, 1.5K, 1/4W, 5%	A13X01797-01	1
29	R19,22,25	Resistor, 2K, 1/4W, 5%	A13X01063-01	3
30	R18,21,24	Resistor, 3K, 1/4W, 5%	A13X01807-01	3

REF NUMBER	SCH REF NUMBER	NOMENCLATURE	REF PART NUMBER	QTY
		PWB Assembly, Control Logic (Cont'd)	91D71835	
31	R31,35,40,42	Resistor, 4.7K, 1/4W, 5%	A13X01860-01	4
32	R1,5,7,27,29,45,49,50,54,56,58,62,63,75,78,79	Resistor, 10K, 1/4W, 5%	A13X01065-01	16
33	R60	Resistor, 15K, 1/4W, 5%	A13X01852-01	1
34	R77	Resistor, 20K, 1/4W, 5%	A13X01781-01	1
35	R69	Resistor, 27K, 1/4W, 5%	A13X02080-01	1
36	R48	Resistor, 43K, 1/4W, 5%	A13X01959-01	1
37	R20,51,61	Resistor, 100K, 1/4W, 5%	A13X01977-01	3
38	R23	Resistor, 200K, 1/4W, 5%	A13X02055-01	1
39	R26	Resistor, 330K, 1/4W, 5%	A13X02049-01	1
40	R12,81	Resistor, 470K, 1/4W, 5%	A13X02085-01	2
41	R32,38	Potentiometer, 25K, 1/2W, 10%	A14X00520-01	2
42	R66,70	Potentiometer, 100K, 30%	A14X00521-01	2
43	C19,28,37	Capacitor, 1000 pf, 100V, 10%	A27X00115-01	3
44	C24,27,29	Capacitor, 0.01 uf, 100V, 10%	A27X00116-01	3
45	C3-12,14,16,20,36,39,40,42-63	Capacitor, 0.1 uf, 50V, 20%	A27X00176-01	38
46	C18,38	Capacitor, 2.7 uf, 10V, 10%	A24X00131-01	2
47	C13,17,21,22,23,25,32,35	Capacitor, 4.7 uf, 10V, 10%	A24X00060-01	8
48	C26,30	Capacitor, 10 uf, 15V, 10%	A24X00118-01	2
49	C1,2,33,34,41	Capacitor, 22 uf, 15V, 10%	A24X00099-01	5
50	C31	Capacitor, 100 uf, 6V, 10%	A24X00110-01	1
51	L1	Inductor, 100 uH, 10%	A31X00338-01	1
52	S1,2	Switch	A43X01287-01	2
54	J2,J3	Jumper Component	A51X00908-01	2
56	S3	Switch, Push Button	A43X01289-01	1
57	C15	Capacitor, 330 uf, 6V, 10%	A24X00133-01	1
59	CR1	Diode, 1N5711	A42X00915-01	1
60	TP1-6	Terminal, Sub-Miniature	A59X00079-01	6
		PWB Assy, Control Logic 91D71835 only		
61	R3	Resistor, 18K	A13X01936-01	1

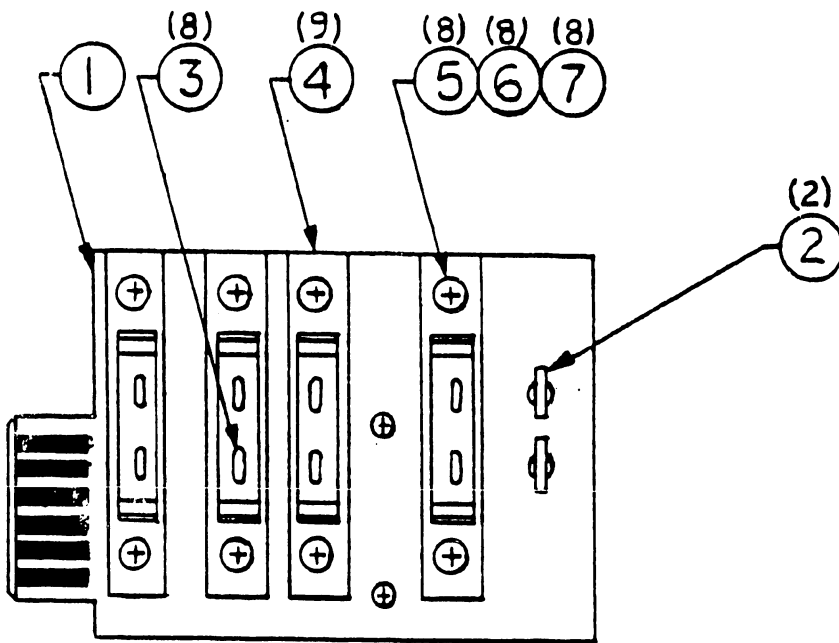

91C71837 Differential Switch

REF NUMBER	SCH REF NUMBER	NOMENCLATURE	REF PART NUMBER	QTY
2		PCB Assembly, Differential Switch	91C71837(C)	
3		Faston, .205 Male	A59X00329-01	2
4		Faston, .187 Female	A59X00414-01	8
5		Clamp, Vacuum Switch Mtg.	A86X00784-01	4
6		Screw, Pan Hd., 4-40 x .312 Lg.	A61X00992-01	8
7		Washer, Flat #4	A63X00627-01	8
8		Nut, Kep 4-40	A62X00029-01	8
8		Switch, Differential	A43C20058-01	3
9		Switch, Differential	A43C20058-02	1

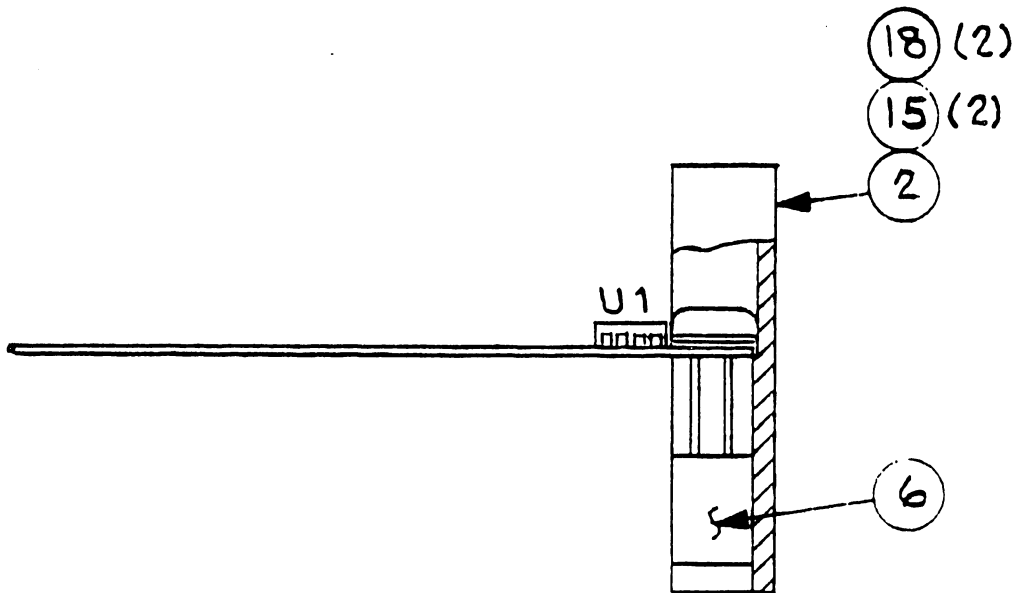
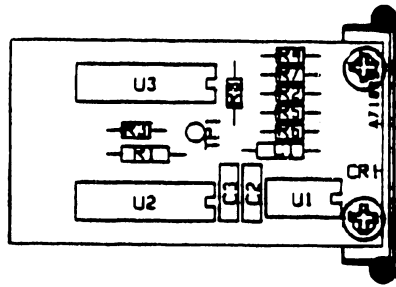

91C71839 Write Enable

REF NUMBER	SCH REF NUMBER	NOMENCLATURE	REF PART NUMBER	QTY
		PWB Assembly, Write Enable	91C71839(1)	
2		Housing, Write Enable	B89C20703-01	1
3	U1	I.C. LM 311	A42\01342-01	1
4	U2	I.C. 74LS00	A42\01445-01	1
5	U3	I.C. 7404	A42\00849-01	1
6	CR1	Optosensor, MCA 7	A42\01557-01	1
7	R1	Resistor, 100 ohm, 1/4W, 5%	A13\01868-01	1
8	R2,7	Resistor, 3.01K, 1/8W, 1%	A13\02124-01	2
9	R3,8	Resistor, 1K, 1/4W, 5%	A13\01277-01	2
10	R4	Resistor, 27K, 1/4W, 5%	A13\02080-01	1
11	R5	Resistor, 100K, 1/4W, 5%	A13\01977-01	1
12	R6	Resistor, 1.5K, 1/4W, 5%	A13\01797-01	1
13	C1	Capacitor, 6.8 uf, 6V, 10%	A24\00065-01	1
14	C2,3	Capacitor, 0.1 uf, 50V, 10%	A27\00146-01	2
15		Screw, Pan Hd. #4x0.312 Lg.	A65\00204-01	2
16	TP1	Terminal, Subminiature	A59\00079-01	1
18		Washer, Nylon #2	A63\00673-01	2

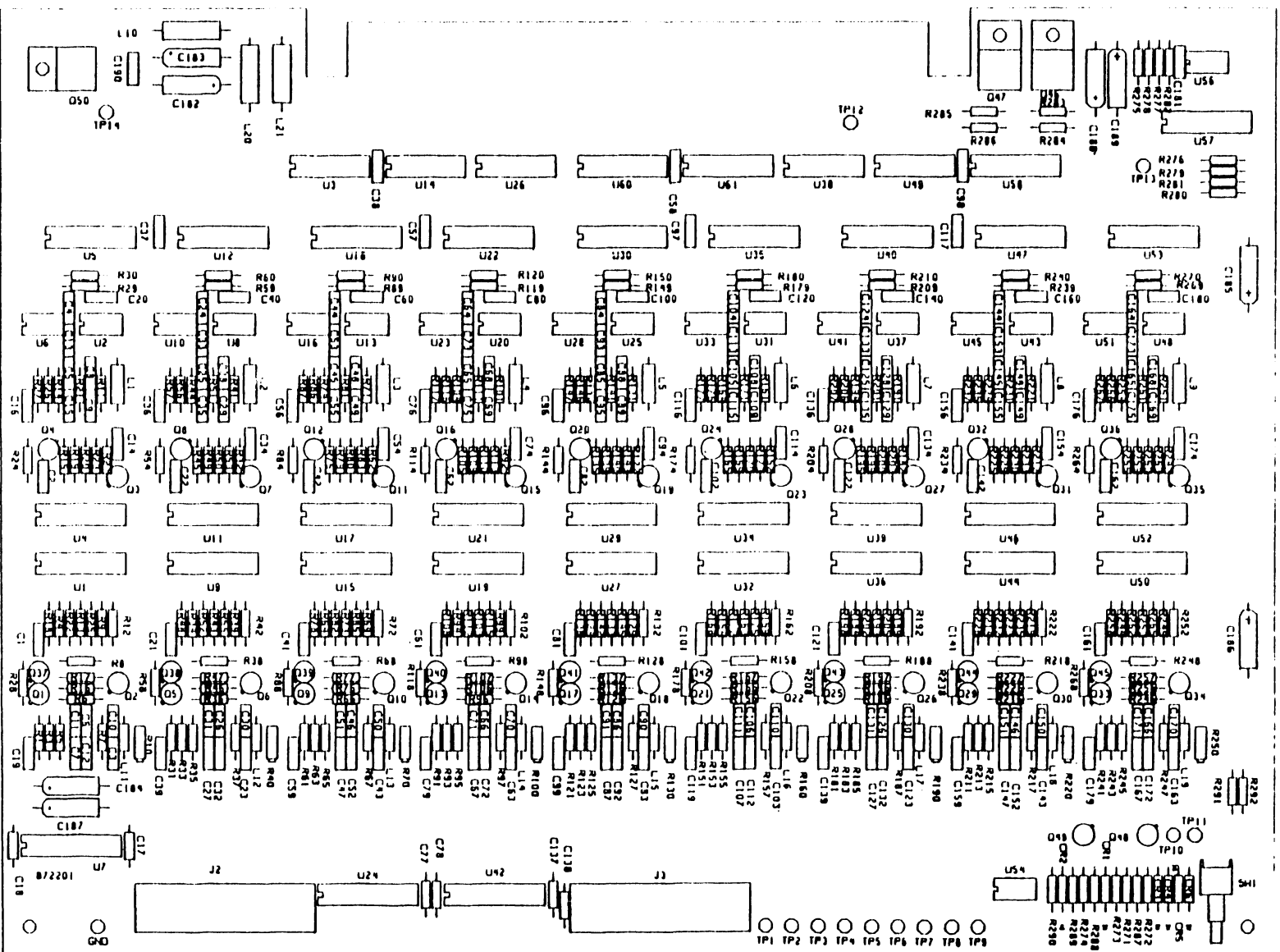

91C72201 PE-GCR Read Electronics

REF NUMBER	SCH REF NUMBER	NOMENCLATURE	REF PART NUMBER	QTY
2	U1,4,9,11, 15,17,19,21, 27,29,32,34, 36,39,44,46, 50,52,57	PWB Assembly PE-GCR Read Electronics I.C. HI-1-0201-5	91C72201(A) A42X01487-01	19
3	U2,8,13,20, 25,31,37,43, 48	I.C. LM360	A42X01361-01	9
4	U3,14,26, 38,49	I.C. 74LS02	A42X01447-01	5
5	U5,12,18,22, 30,35,40,47, 53	I.C. 74LS174	A42X01462-01	9
6	U6,10,16,23, 28,33,41,45, 51	I.C. 311	A42X01342-01	9
7	U7,24,42	I.C. MC3467	A42X01491-01	3
8	U56	I.C. 748	A42X01001-01	1
9	U58	I.C. 74S139	A42X01303-01	1
10	Q50	I.C. 7906	A42X01489-01	1
11	U54	I.C. 393	A42X01619-01	1
12	U60,61	I.C. 74367A	A42X01570-01	2
13	Q1,2,4-6, 8-10,12-14, 16-18,20-22, 24-26,28-30, 32-34,36-45, 48,49	Transistor, 2N3904	A42X00393-01	38
14	Q3,7,11,15, 19,23,27,31, 35	Transistor, 2N2907	A42X00788-01	9
15	Q46	Transistor, 2N6045	A42X01541-01	1
16	Q47	Transistor, 2N6042	A42X01540-01	1
17	CR1-6	Diode, 1N914	A42X00664-01	6
18	R1,31,61,91, 121,151,181, 211,241	Resistor, 1K, 1/8W, 1%	A13X01891-01	9
19	R2,32,62,92, 122,152,182, 212,242	Resistor, 340 ohms, 1/8W, 1%	A13X02287-01	9
20	R3,30,33,60, 63,90,93,120, 123,150,153, 180,183,210, 213,240,243, 268,270,277, 284	Resistor, 47 ohms, 1/4W, 5%	A13X01867-01	21
21	R4,34,64, 94,124,154, 184,214,244	Resistor, 3.40K, 1/8W, 1%	A13X01729-01	9

PWB Assembly PE-GCR Read (Cont'd)		91C72201(A)	
22	R5,7,35,37, 65,67,95,97, 125,127,155, 157,185,187, 215,217,245, 247	Resistor, 3.01K, 1/8W, 1%	A13X02124-01 18
23	R6,25,36,55, 66,85,96,115, 126,145,156, 175,186,205, 216,235,246, 265 (-01,-02,-05) R25,55,85,115, 145,175,205, 235,265(-04)	Resistor, 100 ohms, 1/8W, 1%	A13X02220-01 18
24	R6,36,66,96, 126,156,186, 216,246	Resistor, 133 ohms, 1/8W, 1%	A13X02126-01 9
25	R8,38,68,98, 128,158,188, 218,248	Resistor, 56 ohms, 1/4W, 5%	A13X01939-01 9
26	R8,38,68,98, 128,158,188, 218,248	Resistor, 33 ohms, 1/4W, 5%	A13X01992-01 9
27	R9,39,69,99, 129,159,189, 219,249	Resistor, 1.54K, 1/8W, 1%	A13X01925-01 9
28	R10,40,70, 100,130,160, 190,220,250	Pot, 10K, 1/2W, 10%	A14X00528-01 9
29	R11,29,41, 59,71,89,101, 119,131,149, 161,179,191, 209,221,239, 251,269,273	Resistor, 1K, 1/4W, 5%	A13X01277-01 19
30	R12,42,72,102, 132,162,192, 222,252	Resistor, 909 ohm, 1/8W, 1%	A13X02196-01 9
31	R13,43,73,103, 133,163,193, 223,253,287, 289	Resistor, 2.2K, 1/4W, 5%	A13X01343-01 11
32	R14,21,44,51, 74,81,104, 111,134,141, 164,171,194, 201,224,231, 254,261	Resistor, 1.2K, 1/4W, 5%	A13X01833-01 18

33	R15,45,75, 105,135,165, 195,225,255, 271,272,274	PWB Assembly PE-GCR Read (Cont'd) Resistor, 5.6K, 1/4W, 5%	91C72201(A) A13X01865-01	12
34	R16,17,46,47, 76,77,106,107, 136,137,166, 167,196,197, 226,227,256, 257	Resistor, 1.65K, 1/8W, 1%	A13X02283-01	18
35	R18,48,78, 108,138,168, 198,228,258	Resistor, 619 ohms, 1/8W, 1%	A13X02221-01	9
36	R19,49,79, 109,139,169, 199,229,259	Resistor, 100 ohms, 1/4W, 5%	A13X01868-01	9
37	R20,50,80,110, 140,170,200, 230,260	Resistor, 1.5K, 1/4W, 5%	A13X01797-01	9
38	R22,52,82,112, 142,172,202, 232,262	Resistor, 274 ohms 1/8W, 1%	A13X02476-01	9
39	R23,53,83,113, 143,173,203, 233,263	Resistor, 3.92K, 1/8W, 1%	A13X01997-01	9
40	R24,54,84,114, 144,174,204, 234,264	Resistor, 2K, 1/8W, 1%	A13X01874-01	9
41	R26,56,86,116, 146,176,206, 236,266,279, 281	Resistor, 4.02K, 1/8W, 1%	A13X01892-01	11
42	R27,57,87,117, 147,177,207, 237,267,282, 288,290	Resistor, 10K, 1/4W, 5%	A13X01065-01	12
43	R28,58,88,118, 148,178,208, 238,268,285, 283	Resistor, 549 ohms, 1/8W, 1%	A13X02475-01	11
44	R275	Resistor, 182K, 1/8W, 1%	A13X02483-01	1
45	R276,280	Resistor, 2.49K, 1/8W, 1%	A13X01895-01	2
46	R278	Resistor, 24.3K, 1/8W, 1%	A13X01731-01	1
47	C1,5,21,25, 41,45,61,65, 81,85,101, 105,121,125, 141,145,161, 165,190	Capacitor, 0.33uf, 50V, 20%	A27X00142-01	19
48	C2,22,42,62, 82,102,122, 142,162	Capacitor, 270 pf, 200V, 10%	A27X00186-01	9

49	C3,23,43,63, 83,103,123, 143,163(-04&-05) C7,27,47,67, 87,107,127,147, 167(-04 only) C10,30,50,70, 90,110,130, 150,170(-02 &-05)	PWB Assembly PE-GCR Read (Cont'd) Capacitor, .0022uf, 100V, 10%	91C72201(A) A27X00151-01	18
50	C3,23,43,63, 83,103,123, 143,163	Capacitor, .0056uf, 100V, 10%	A27X00195-01	9
51	C3,23,43,63, 83,103,123, 143,163(-01 only) C6,26,46,66, 86,106,126, 146,166(-02 only)	Capacitor, .01uf, 100V, 10%	A27X00196-01	9
52	C4,11-13,15, 19,24,31-33,35, 37-39,44,51- 53,55,57-59, 64,71-73, 75,79,84, 91-93,95,97- 99,104,111- 113,115,117, 119,124,131- 133,135,139, 144,151-153, 155,159,164, 171-173,175, 179	Capacitor, 0.1uf, 50V, 10%	A27X00146-01	61
53	C6,26,46,66, 86,106,126, 146,166(-04 & -05) C7,27,47,67, 87,107,127, 147,167(-01, -02 & -05)	Capacitor, .0047uf, 100V, 10%	A27X00209-01	18
54	C6,26,46,66, 86,106,126, 146,166	Capacitor, .022uf, 50V, 10%	A27X00232-01	9

55	C8,9,28,29,48, 49,68,69,88, 89,108,109, 128,129,148, 149,168,169	PWB Assembly PE-GCR Read (Cont'd) Capacitor, 200pf, 300V, 5%	91C72201(A) A21X00637-01	18
56	C8,9,28,29, 48,49,68,69, 88,89,108, 109,128,129, 148,149,168, 169	Capacitor, 120pf, 100V, 5%	A21X00664-01	18
57	C8,9,28,29, 48,49,68,69, 88,89,108, 109,128,129, 148,149,168, 169	Capacitor, 330pf, 100V, 5%	A21X00674-01	18
58	C16,36,56,76, 96,116,136, 156,176 C10,30,50,70, 90,110,130, 150,170(-04)	Capacitor, 1000pf, 200V, 10%	A27X00145-01	9
59	C10,30,50,70, 90,110,130, 150,170	Capacitor, .0018uf, 100V, 10%	A27X00192-01	9
60	C14,34,54,74, 94,114,134, 154,174	Capacitor, 8.2uf, 15V, 10%	A24X00122-01	9
61	C17,18,77,78, 137,138	Capacitor, 0.1uf, 50V, 20%	A27X00176-01	6
62	C20,40,60,80, 100,120,140, 160,180,181	Capacitor, 91pf, 100V, 5%	A21X00559-01	10
63	C182,183,184, 185,186,187, 188,189	Capacitor, 22uf, 15V, 10%	A24X00099-01	8
64	L1-9	Inductor, 390uh, 5%	A31X00355-01	9
65	L1-9	Inductor, 220uh, 10%	A31X00331-01	9
66	L1-9	Inductor, 680uh, 5%	A31X00302-01	9
67	L11-19	Inductor, 82uh, 10%	A31X00349-01	9
68	L11-19	Inductor, 56uh, 10%	A31X00348-01	9
69	L11-19	Inductor, 150uh, 10%	A31X00360-01	9
70	L10,20,21	Inductor, 50uh, 10%	A31X00350-01	3
71	XU59	Heat Sink	A66X01669-01	1
72		Nut, Kep, 4-40	A62X00029-01	3
73		Screw, Pan Hd. 4-40x.312 L.g.	A61X00992-01	3

74	J2	PWB Assembly PE-GCR Read (Cont'd)	91C72201(A)	
75		Connector, 34 Pin	A55X01400-01	1
76	R291,292	Terminal, Turret TP1-14, TP-GND	A59X00015-01	15
77	J3	Jumper Component	A51X00908-01	2
		Header Assy, 26 Pin	A55X01523-01	1

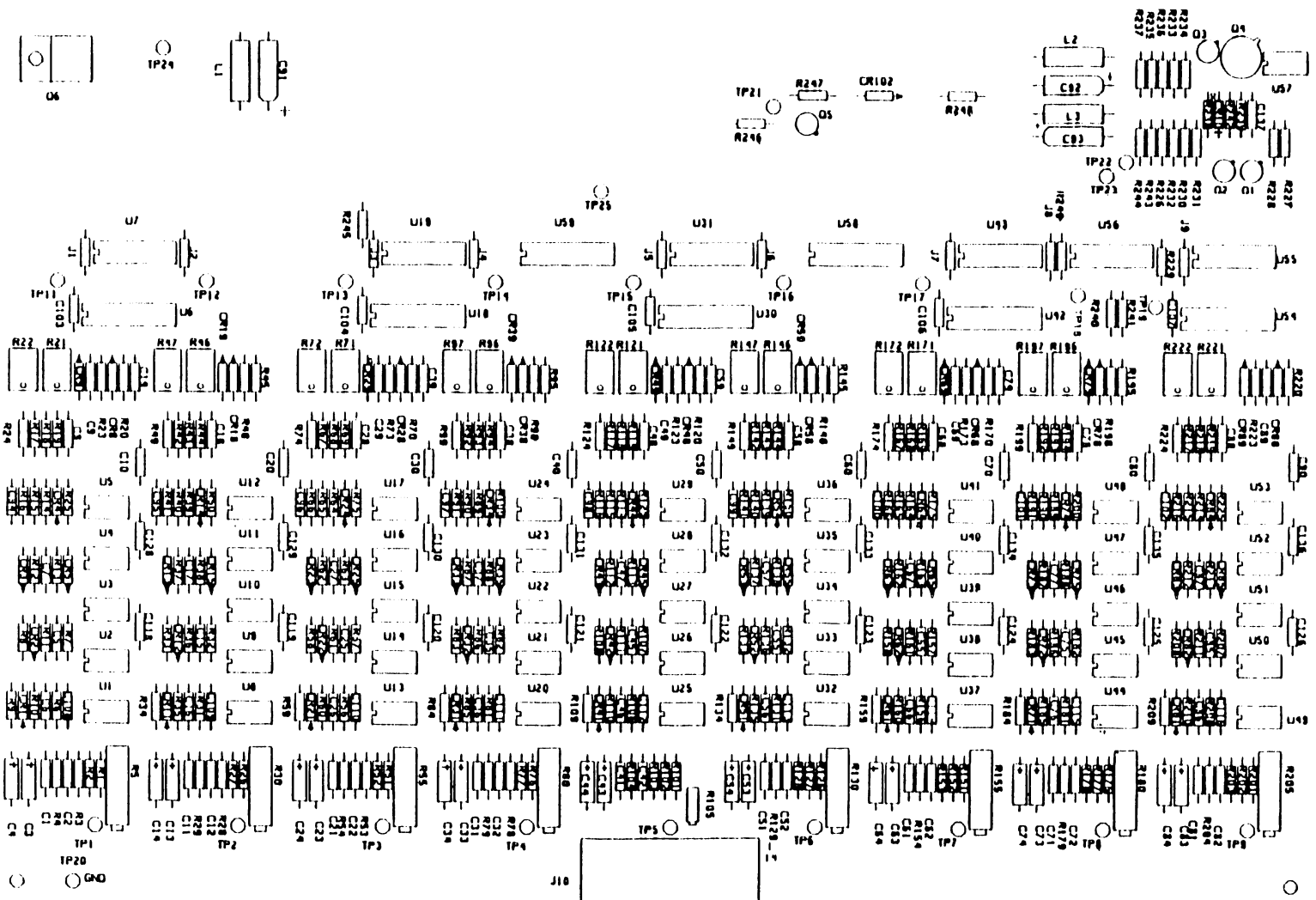

91C72202 NRZE Read Electronics

REF NUMBER	SCH REF NUMBER	NOMENCLATURE	REF PART NUMBER	QTY
2	U1,2,3,8,9, 10,13,14,15, 20,21,22,25, 26,27,32,33, 34,37,38,39, 44,45,46,49, 50,51	PWB Assembly, NRZI Read Electronics I.C. 318	91C72202(A) A42X01346-01	27
3	U4,5,11,12, 16,17,23,24, 28,29,35,36, 40,41,47,48, 52,53	I.C. 311	A42X01342-01	18
4	U6,18,30,42,54	I.C. 96L02	A42X01494-01	5
6	U56	I.C. 7406	A42X01007-01	1
7	U57	I.C. 748	A42X01001-01	1
8	U58,59	I.C. 74367A	A42X01570-01	2
9	Q6	I.C. 7906	A42X01489-01	1
10	CR1,2,4,5,11, 12,14,15,21,22, 24,25,31,32,34, 35,41,42,44,45, 51,52,54,55,61, 62,64,65,71,72, 74,75,81,82,84, 85	Diode, 1N5711	A42X00915-01	36
11	CR3,8,9,13, 18,19,23,28,29, 33,38,39,43,48, 49,53,58,59,63, 68,69,73,78,79, 83,88,89,101	Diode, 1N914	A42X00664-01	28
12	Q1,2,3,5	Transistor, 2N2907	A42X00788-01	4
13	Q4	Transistor, 2N2905	A42X00392-01	1
14	R1,2,26,27, 51,52,76,77, 101,102,126, 127,151,152, 176,177,201, 202	Resistor, 6.04K, 1/8W, 1%	A13X01898-01	18
15	R3,4,28,29, 53,54,78,79, 103,104,128, 129,153,154, 178,179,203, 204	Resistor, 40.2K, 1/8W, 1%	A13X01989-01	18

PWB Assembly, NRZI Read Electronics 91C72202(A)
(Cont'd)

16	R3,4,28,29, 53,54,78,79, 103,104,128, 129,153,154, 178,179,203, 204	Resistor, 64.9K, 1/8W, 1%	A13X02219-01	18
17	R3,4,28,29, 53,54,78,79 103,104,128, 129,153,154, 178,179,203, 204	Resistor, 100K, 1/8W, 1%	A13X01876-01	18
18	R5,30,55,80, 130,155,180 205	Potentiometer, 2K, 3/4W, 5%	A14X00498-01	8
19	R6,7,31,32, 56,57,81,82, 106,107,131, 132,156,157, 181,182,206, 207	Resistor, 8.87K, 1/8W, 1%	A13X01889-01	18
20	R8,33,58,83, 108,133,158, 183,208	Resistor, 12.1K, 1/8W, 1%	A13X02284-01	9
21	R9,34,59,84, 109,134,159, 184,209	Resistor, 6.81K, 1/8W, 1%	A13X02100-01	9
22	R10,11,35,36, 60,61,85,86, 110,111,135, 136,160,161, 185,186,210, 211	Resistor, 32.4K, 1/8W, 1%	A13X01884-01	18
23	R12,37,62,87, 112,137,162, 187,212,229, 233,238,247, 249	Resistor, 2K, 1/4W, 5%	A13X01063-01	14
24	R13,38,63,88, 113,138,163, 188,213	Resistor, 5.11K, 1/8W, 1%	A13X01896-01	9
25	R14,39,64,89, 114,139,164, 189,214,243, 244	Resistor, 100 ohm, 1/4W, 5%	A13X01868-01	11
26	R15,25,40,50, 65,75,90,100, 115,125,140, 150,165,175, 190,200,215, 225	Resistor, 10K, 1/4W, 5%	A13X01065-01	18

PWB Assembly, NRZI Read Electronics 91C72202(A)
(Cont'd)

27	R16,18,20,41, 43,45,66,68, 70,91,93,95, 116,118,120, 141,143,145, 166,168,170, 191,193,195, 216,218,220, 226,228,230, 232,239,245,	Resistor, 1K, 1/4W, 5%	A13X01277-01	33
28	R17,42,67,92, 117,142,167, 192,217	Resistor, 2.2K, 1/4W, 5%	A13X01343-01	9
29	R19,44,69,94, 119,144,169, 194,219	Resistor, 22K, 1/4W, 5%	A13X01866-01	9
30	R21,22,46,47, 71,72,96,97, 121,122,146, 147,171,172, 196,197,221, 222	Potentiometer, 100K, 1/2W, 10%	A14X00494-01	18
31	R23,48,73,98, 123,148,173, 198,223	Resistor, 18K, 1/4W, 5%	A13X01936-01	9
32	R24,49,74,99, 124,149,174, 199,224	Resistor, 8.2K, 1/4W, 5%	A13X01801-01	9
33	R227,231,234, 246	Resistor, 510 ohm, 1/4W, 5%	A13X01811-01	4
34	R235	Resistor, 1.62K, 1/8W, 1%	A13X02375-01	1
35	R236	Resistor, 6.49K, 1/8W, 1%	A13X01871-01	1
36	R242	Resistor, 10 ohm, 1/4W, 5%	A13X01864-01	1
37	R248	Resistor, 9.31K, 1/8W, 1%	A13X01869-01	1
38	C1,2,11,12,21, 22,31,32,41, 42,51,52,61, 62,71,72,81, 82	Capacitor, 22pf, 100V, 10%	A27X00109-01	18
39	C3,4,13,14, 23,24,33,34, 43,44,53,54, 63,64,73,74, 83,84	Capacitor, 3.3uf, 15V, 10%	A24X00053-01	18
40	C5,7,9,15,17, 19,25,27,29,35, 37,39,45,47,49, 55,57,59,65,67, 69,75,77,79,85, 87,89(-01) C8,18,28,38, 48,58,68,78, 88(-04 only)	Capacitor, 270pf, 50V, 10%	A27X00181-01	27

		PWB Assembly, NRZI Read Electronics	91C72202(A)		
41	C5,15,25,35, 45,55,65,75, 85	Capacitor, 180pf, 100V, 10%	A27X00219-01	9	
42	C137(-01,-02) C5,7,9,15,17, 19,25,27,29, 35,37,39,45, 47,49,55,57, 59,65,67,69, 75,77,79,85, 87,89(-04 only)	Capacitor, 100pf, 100V, 10%	A27X00113-01	1	
43	C6,16,26,36, 46,56,66,76, 86	Capacitor, 82pf, 100V, 10%	A27X00112-01	9	
44	C6,16,26,36, 46,56,66,76, 86	Capacitor, 47pf, 100V, 10%	A27X00111-01	9	
45	C6,16,26,36, 46,56,66,76, 86	Capacitor, 27pf, 100V, 10%	A27X00218-01	9	
46	C7,9,17,19, 27,29,37,39, 47,49,57,59, 67,69,77,79, 87,89	Capacitor, 150pf, 100V, 10%	A27X00136-01	18	
47	C8,18,28,38, 48,58,68,78, 88	Capacitor, 820pf, 100V, 10%	A27X00231-01	9	
48	C8,18,28,38, 48,58,68,78, 88	Capacitor, 470pf, 100V, 10%	A27X00173-01	9	
49	C10,20,30,40, 50,60,70,80, 90,94-116,118- 126,128-136, 138	Capacitor, 0.1uf, 50V, 20%	A27X00176-01	51	
50	C91,92,93	Capacitor, 15uf, 20V, 1u%	A24X00048-01	3	
51	L1,2,3	Inductor, 50uh, 10%	A31X00350-01	3	
52	XQ1,2,3,5	Pad, Transistor, TO-18	A42X00936-01	4	
53	XQ4	Pad, Transistor, TO-5	A42X00935-01	1	
54	XQ6	Heat Sink, TO-220	A66X01669-01	1	
55		Nut, Kep, 4-40	A62X00029-01	1	
56		Screw, Pan Hd, 4-40x.312 LG.	A61X00992-01	1	
57	TP1-9,11-25	Terminal, Turret	A59X00015-01	24	
58	J1-9,J11	Jumper	A51X00908-01	10	
59	R105	Potentiometer, 2K, 1W, 10%	A14X00386-01	1	
60	J10	Header Assy, 26 Pin	A55X01523-01	1	

91C72203 Telex Interface

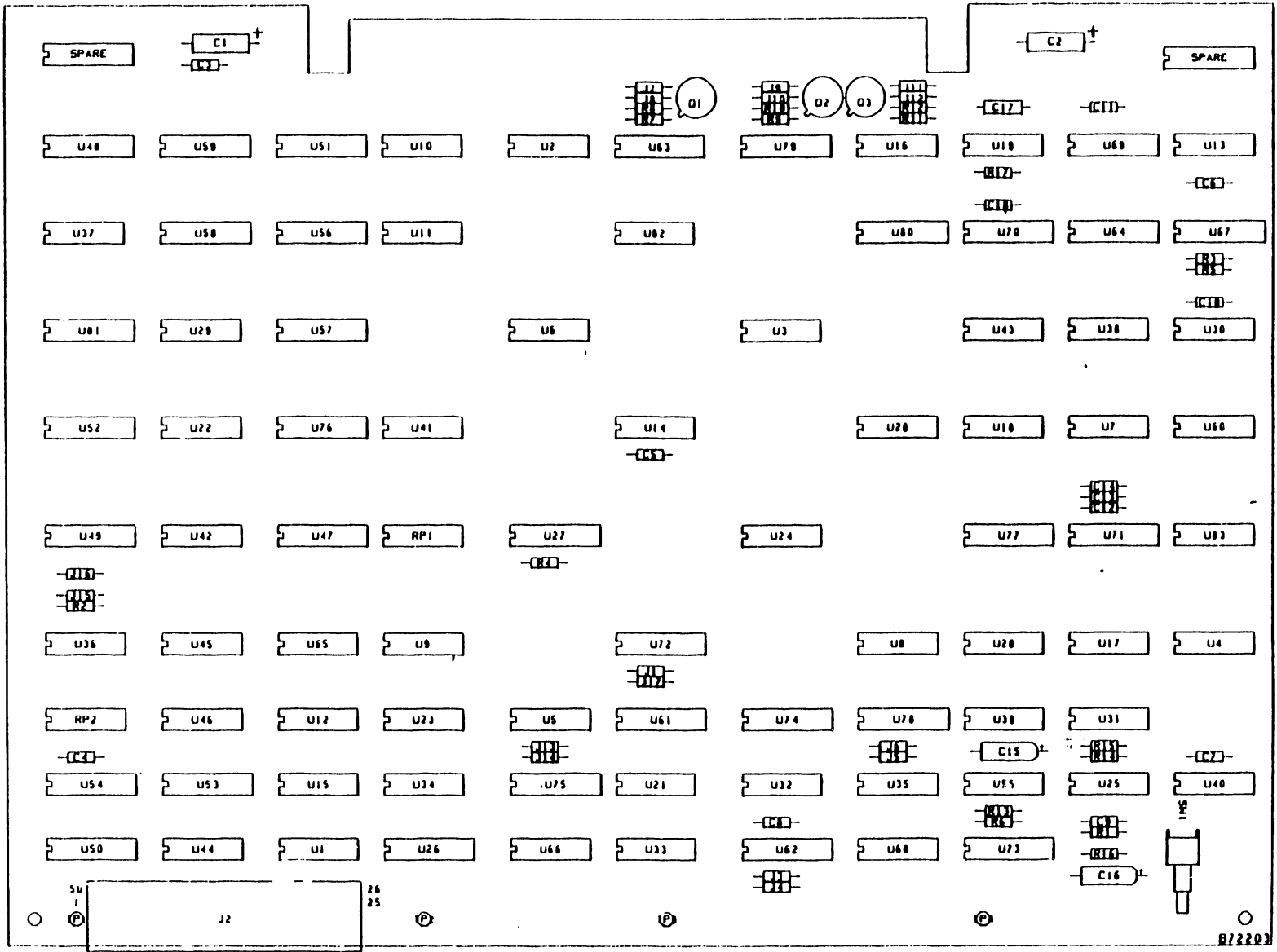

REF NUMBER	SCH REF NUMBER	NOMENCLATURE	REF PART NUMBER	QTY
		PWB Assembly Telex Interface	91C72203(A)	
2	U1-6	I.C. 74LS00	A42X01445-01	6
3	U7-13	I.C. 74LS02	A42X01447-01	7
4	U14-19	I.C. 74LS04	A42X01396-01	6
5	U20,21,22	I.C. 74LS08	A42X01395-01	3
6	U23,24,55	I.C. 74LS10	A42X01448-01	3
7	U25	I.C. 74LS14	A42X01493-01	1
8	U28,29	I.C. 74LS32	A42X01485-01	2
9	U60	I.C. 74LS51	A42X01500-01	1
10	U30-43	I.C. 74LS74A	A42X01452-01	14
11	U26,27	I.C. 74LS75	A42X01504-01	2
12	U83	I.C. 74LS86	A42X01454-01	1
13	U68	I.C. 74LS93	A42X01509-01	1
14	U44,45,46	I.C. 74LS132	A42X01495-01	3
15	U61	I.C. 74LS138	A42X01456-01	1
16	U62,72-78	I.C. 74LS151	A42X01457-01	8
17	U63,79	I.C. 74LS157	A42X01459-01	2
18	U64,80,81	I.C. 74LS161A	A42X01460-01	3
19	U65,82	I.C. 74LS280	A42X01470-01	2
20	U66	I.C. 74LS293	A42X01531-01	1
21	U47	I.C. 74LS368	A42X01590-01	1
22	U67	I.C. 96L02	A42X01494-01	1
23	U48-54,56-59	I.C. 8T23	A42X01077-01	11
24	U69	I.C. Prom (256X4)	A42X20216-01	1
25	U70	I.C. Prom (256X4)	A42X20234-01	1
26	U71	I.C. Prom	A42A20252-01	1
27	RP1,2	Resistor, Pack, 91 ohm	A13X02448-01	2
28	Q1,2,3	Transistor, 2N2222	A42X00822-01	3
29	R15,17	Resistor, 100 ohm, 1/4W, 5%	A13X01868-01	2
30	R1	Resistor, 560 ohm, 1/4W, 5%	A13X01974-01	1
31	R2,4,6,16	Resistor, 1K, 1/4W, 5%	A13X01277-01	4
32	R7-12	Resistor, 2.4K, 1/4W, 5%	A13X01800-01	6
33	R5,13,14	Resistor, 10K, 1/4W, 5%	A13X01065-01	3
34	R3	Resistor, 20K, 1/4W, 5%	A13X01781-01	1
35	C17	Capacitor, .068uf, 50V, 2%	A22X00851-01	1
36	C16	Capacitor, 6.8uf, 6V, 10%	A24X00065-01	1
37	C1,2	Capacitor, 22uf, 15V, 10%	A24X00099-01	2
38	C15	Capacitor, 10uf, 15V, 10%	A24X00118-01	1
39	C11-14,18	Capacitor, 1500pf, 100V, 10%	A27X00138-01	5
40	C8	Capacitor, .0033uf, 100V, 10%	A27X00141-01	1
41	C3-7,10	Capacitor, .1uf, 50V, 20%	A27X00176-01	6
42	C9	Capacitor, 270pf, 50V, 10%	A27X00181-01	1
43	S1	Switch, Toggle, SPDT	A43X01287-01	1
44	TP1,2,3,4	Terminal, Turret	A59X00015-01	4
45	XU69,70,71	I.C. Socket	A42X01161-01	3
46	J2	Connector, 50 Pin	A55X01401-01	1
47		Jumper Component	A51X00908-01	

91C72204 Operator Control Panel

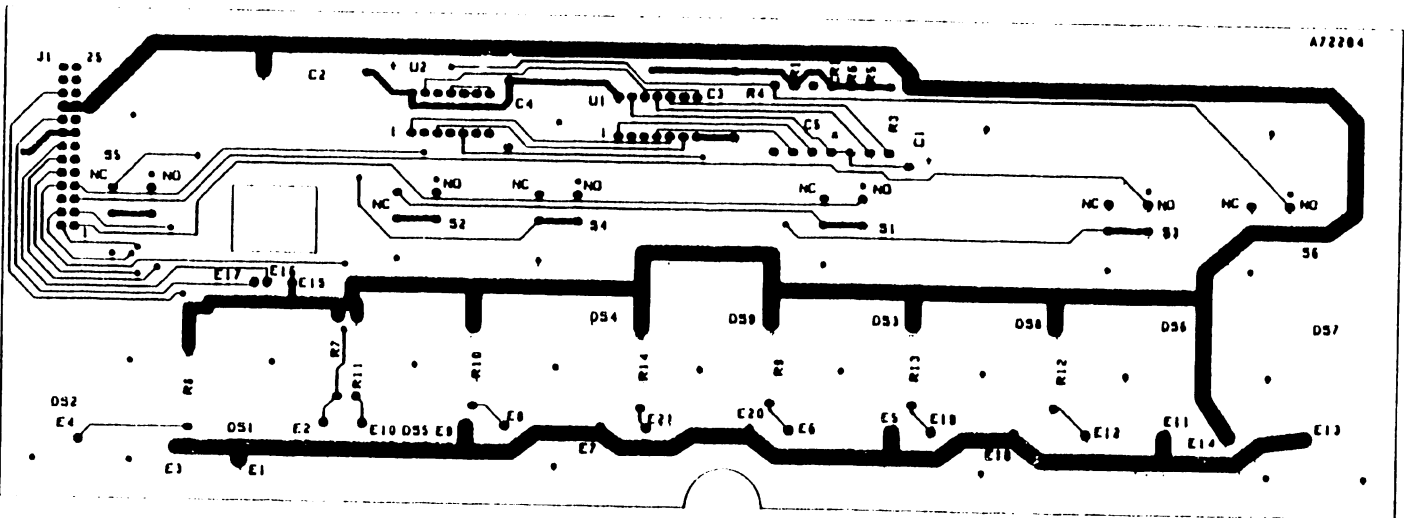

REF NUMBER	SCH REF NUMBER	NOMENCLATURE	REF PART NUMBER	QTY
2		PWB Assembly Operator Control Panel	91D72204(A)	
3	S1-6	Bracket Indicator Mounting	A71C21225-01	1
4	XDS1-9	Switch, White	A43X01283-01	6
5		Indicator Assembly	A41X00379-01	9
6		Lens Cap, Red	A41X00380-01	2
7		Lens Cap, White	A41X00381-01	6
8	U1	Lens Cap, Green	A41X00382-01	1
9	U2	I.C., 74LS74	A42X01452-01	1
10	CR1	I.C., 74LS05	A42X01536-01	1
11	C1	Diode, IN914	A42X00664-01	1
12	R1,3-6	Capacitor, 10uf, 15V, 10%	A24X00118-01	1
13	R7-14	Resistor, 1K, 1/4W, 5%	A13X01277-01	5
14		Resistor, 330 ohm, 1/2W, 5%	A13X00505-01	8
15	C2	Wire Stranded, 22 AWG, White	A51X00939-01	1'
16	R15-23	Capacitor, 100uf, 10V, 10%	A24X00117-01	1
17	C3,4	Resistor, 18 ohm, 1/4W, 5%	A13X01900-01	9
18		Capacitor, 0.1uf, 50V, 20%	A27X00176-01	2
19		Screw Pan Head, 6-32x0.31 Lg.	A61X01076-01	2
20	J1	Nut, Kep, 6-32	A62X00010-01	2
21	DS1-9	Header, 26 Pin	A55X01538-01	1
22	C5	Lamp, CM 386	A41X00323-01	9
		Capacitor, .001uf, 100V, 10%	A27X00115-01	1

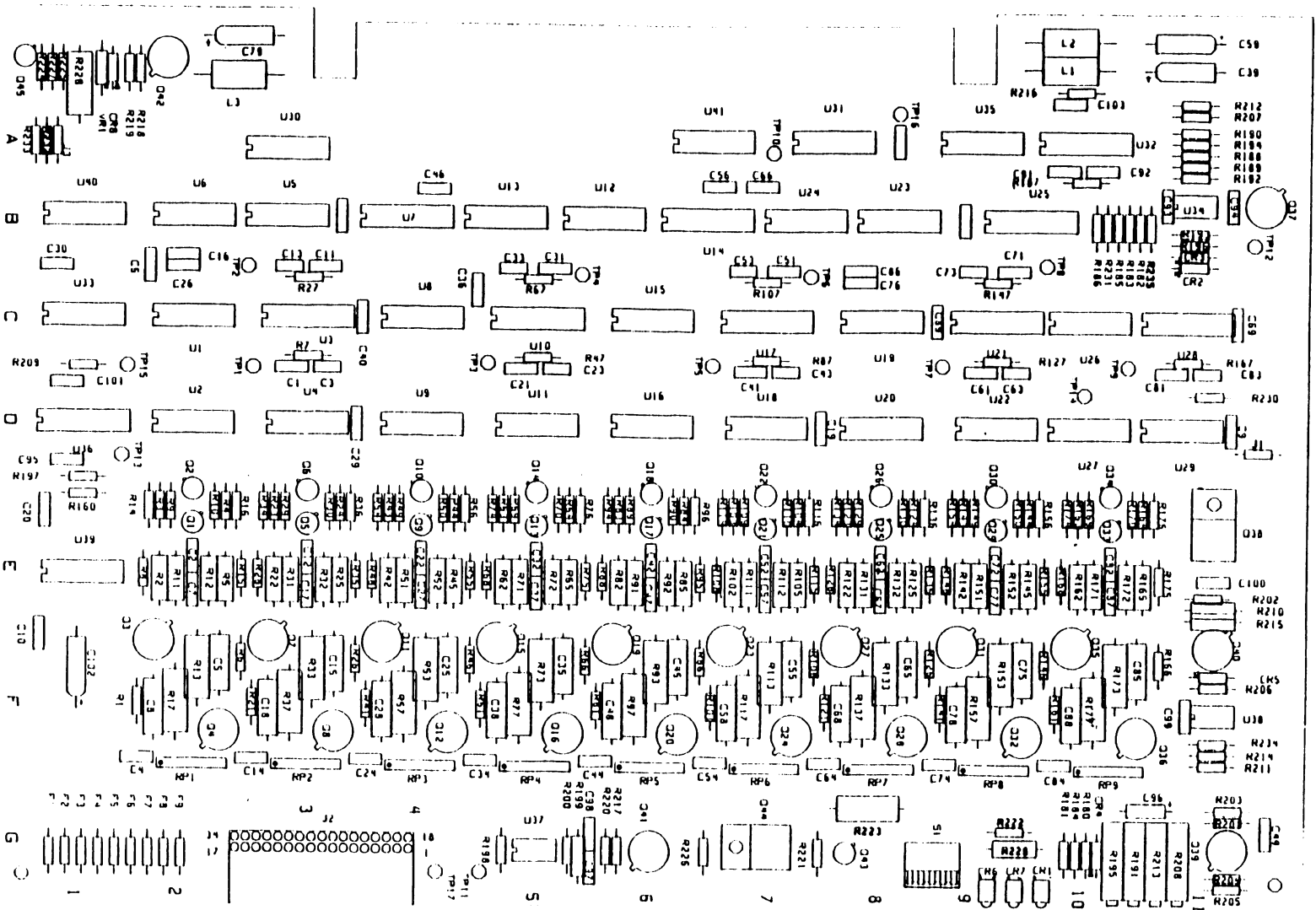

91C72205 Write Electronics

REF NUMBER	SCH REF NUMBER	NOMENCLATURE	REF PART NUMBER	QTY
		PWB Assembly, Write Electronics	91C72205(A)	
2	U1,8,15,19,26	I.C. 74S00	A42X01035-01	5
3	U2,9,16,20,27,39	I.C. 7426	A42X01028-01	6
4	U3,10,17,21, 28	I.C. 74221	A42X01562-01	5
5	U4,11,18,22, 29,35	I.C. 7406	A42X01007-01	6
6	U5,12,23	I.C. 74LS86	A42X01454-01	3
7	U6,13,24	I.C. 74C04	A42X01567-01	3
8	U7,14,25	I.C. 74LS157	A42X01459-01	3
9	U30	I.C. 74LS74A	A42X01452-01	1
10	U31,33,41	I.C. 74LS00	A42X01445-01	3
11	U32	I.C. 96S02	A42X01631-01	1
12	U34,38	I.C. 748	A42X01001-01	2
13	U36	I.C. 96L02	A42X01494-01	1
14	U37	I.C., 555 Timer	A42X01306-01	1
15	U40	I.C., 74LS04	A42X01396-01	1
16	Q1,2,5,6,9, 10,13,14,17, 18,21,22,25, 26,29,30,33, 34	Transistor, 2N2907	A42X00788-01	18
17	Q3,4,7,8, 11,12,15,16, 19,20,23,24 27,28,31,32, 35,36,39,41, 42	Transistor, 2N2905	A42X00392-01	21
18	Q37	Transistor, 2N5322	A42X00772-01	1
19	Q38	Transistor, 2N6126	A42X01023-01	1
20	Q40	Transistor, 2N2219	A42X00670-01	1
21	Q43,45	Transistor, 2N2222	A42X00822-01	2
22	Q44	Transistor, 2N6101	A42X01024-01	1
23	CR1,6,7	LED, PCH 125	A42X01486-01	3
24	CR2-5,8	Diode, IN914	A42X00664-01	5
25	VR1	Diode, Zener 1N4744	A42X00444-01	1
26	RP1-9	Resistor Pack, 560 ohm	A13X02484-01	9
27	R1,6,21,26, 41,46,61,66, 81,86,101, 106,121,126, 141,146,161, 166,188,193, 196,211,214	Resistor, 1K, 1/8W, 1%	A13X01891-01	23

		PWB Assembly, Write Electronics (Cont'd)	91C72205(A)	
28	R2,5,11, 12,22,25,31, 32,42,45,51, 52,62,65,71, 72,82,85,91, 92,102,105, 111,112,122, 125,131,132, 142,145,151, 152,162,165, 171,172,215	Resistor, 200 ohms, 1/2W, 1%	A13X02513-01	37
29	R3,4,23,24, 43,44,63,64, 83,84,103, 104,123,124, 143,144,160, 163,164,184, 189,204,206, 217,218,221, 222,224,227, 230,231	Resistor, 1K, 1/4W, 5%	A13X01277-01	31
30	R7,27,47,67, 87,107,127, 147,167	Resistor, 3.92K, 1/8W, 1%	A13X01997-01	9
31	R8,15,28,35, 48,55,68,75, 88,95,108, 115,128,135, 148,155,168, 175	Resistor, 221 ohms, 1/8W, 1%	A13X01877-01	18
32	R9,10,29,30, 49,50,69,70, 89,90,109, 110,129,130, 149,150,169, 170,198,205, 219,220,225	Resistor, 2.2K, 1/4W, 5%	A13X01343-01	23
33	R13,17,33,37, 53,57,73,77, 93,97,113, 117,133,137, 153,157,173, 177	Resistor, 120 ohms, 1W, 5%	A13X00392-01	18
34	R14,16,34,36, 54,56,74,76, 94,96,114, 116,134,136, 154,156,174, 176	Resistor, 1.21K, 1/8W, 1%	A13X02046-01	18
35	R180,190,194, 201,207,212 R234 (-1,-2, -4,-5)	Resistor, 100 ohms, 1/4W, 5%	A13X01868-01	7

		PWB Assembly, Write Electronics (Cont'd)	91C72205(A)	
36	R181,187	Resistor, 330 ohms, 1/4W, 5%	A13X01832-01	2
37	R182	Resistor, 24.9K, 1/8W, 1%	A13X02103-01	1
38	R182,186	Resistor, 24.3K, 1/8W, 1%	A13X01731-01	2
39	R182	Resistor, 26.1K, 1/8W, 1%	A13X02503-01	1
40	R183	Resistor, 8.06K, 1/8W, 1%	A13X01875-01	1
41	R183	Resistor, 7.87K, 1/8W, 1%	A13X02168-01	1
42	R185 (-2,-7) R183 (-4,-5,-9, -10)	Resistor, 8.45K, 1/8W, 1%	A13X02515-01	1
43	R185	Resistor, 8.87K, 1/8W, 1%	A13X01889-01	1
44	R185	Resistor, 9.31K, 1/8W, 1%	A13X01869-01	1
45	R185	Resistor, 21K, 1/8W, 1%	A13X01897-01	1
46	R235	Resistor, 2.71K, 1/8W, 1%	A13X01715-01	1
47	R235	Resistor, 2.1K, 1/8W, 1%	A13X02096-01	1
48	R235	Resistor, 4.22K, 1/8W, 1%	A13X02517-01	1
49	R186	Resistor, 25.5K, 1/8W, 1%	A13X02519-01	1
50	R186	Resistor, 26.7K, 1/8W, 1%	A13X02508-01	1
51	R191,195,208, 213	POT, 1K, 3/4W, 5%	A14X00492-01	4
52	R192,232,233	Resistor, 10K, 1/4W, 5%	A13X01065-01	3
53	R197,209	Resistor, 64.9K, 1/8W, 1%	A13X02219-01	2
54	R197,209	Resistor, 37.4K, 1/8W, 1%	A13X02456-01	2
55	R197,209	Resistor, 20.5K, 1/8W, 1%	A13X01893-01	2
56	R199	Resistor, 17.4K, 1/4W, 1%	A13X02317-01	1
57	R200	Resistor, 10K, 1/8W, 1%	A13X00302-01	1
58	R202,226	Resistor, 510 ohms, 1/4W, 5%	A13X01811-01	2
59	R203	Resistor, 909 ohms, 1/8W, 1%	A13X02196-01	1
60	R210	Resistor, 100 ohms, 1/2W, 5%	A13X00503-01	1
61	R216	Resistor, 39.2K, 1/8W, 1%	A13X02098-01	1
62	R223	Resistor, 360 ohms, 1W, 5%	A13X01649-01	1
63	R228	Resistor, 100 ohms, 1W, 5%	A13X00595-01	1
64	R229	Resistor, 2.2K, 1/2W, 5%	A13X02519-01	1
65	C1,2,7,9,10, 11,12,17,19, 20,21,22,27, 29,30,31,32, 37,40-42,47, 49,51,52,57, 61,62,67,69, 71,72,77,81, 82,87,89,104, 105,106	Capacitor, .1uf, 50V, 10%	A27X00146-01	40
66	C3,13,23,33, 43,53,63,73, 83	Capacitor, 200pf, 300V, 5%	A21X00637-01	9
67	C4,14,24,34, 44,54,64,74, 84	Capacitor, 51pf, 100V, 5%	A21X00642-01	9
68	C5,8,15,18, 25,28,35,38, 45,48,55,58, 65,68,75,78, 85,88	Capacitor, .1uf, 100V, 10%	A22X00724-01	18

		PWB Assembly, Write Electronics (Cont'd)	
69	C6,16,26,36, 46,56,66,76, 86,94,100	Capacitor, 100pf, 200V, 10%	91C72205(A) A27X00184-01 11
70	C39,59	Capacitor, 68uf, 15V, 10%	A24X00068-01 2
71	C79,102	Capacitor, 15uf, 20V, 10%	A24X00048-01 2
72	C91	Capacitor, 2000pf, 100V, 1%	A27X00223-01 1
73	C91	Capacitor, 1200pf, 100V, 1%	A27X00222-01 1
74	C91	Capacitor, 620pf, 100V, 1%	A27X00220-01 1
75	C92	Capacitor, 150pf, 200V, 10%	A27X00203-01 1
76	C93	Capacitor, 33pf, 100V, 5%	A21X00639-01 1
77	C95,101	Capacitor, 3300pf, 50V, 10%	A27X00124-01 2
78	C96	Capacitor, 1uf, 20V, 10%	A24X00096-01 1
79	C97,98	Capacitor, .01uf, 100V, 10%	A27X00196-01 2
80	C99	Capacitor, 270pf, 100V, 5%	A21X00644-01 1
81	C103	Capacitor, 0.33uf, 50V, 20%	A27X00142-01 1
82	L1,2,3	Inductor, 50uh, 10%	A31X00350-01 3
83	S1	Switch, Dip, SPST, (5)	A43X01329-01 1
84	F1-9	Fuse, 0.25 AMP, 125V	A53X00104-01 9
85	TP1-17	Terminal, Turret	A59X00015-01 17
86	J3	Jumper Component	A51X00908-01 1
87	J2	Connector, 34 Pin	A55X01400-01 1
88	XQ1,2,5,6,9, 10,13,14,17, 18,21,22,25, 26,29,30,33, 34,43,45	Transistor Pad TO18	A42X00936-01 20
89	XQ3,4,7,8,11, 12,15,16,19, 20,23,24,27, 27,28,31,32, 35,36,37, 39-42	Transistor Pad TO5	A42X00935-01 23
90	XQ3,4,7,8,11, 12,15,16,19, 20,23,24,27, 28,31,32,35, 36	Heat Sink, TO5	A42X00787-01 18
91	XQ38	Heat Sink	A66X01669-01 1
92		Screw, Pan Hd. 4-40x.312 Lg.	A61X00992-01 2
93		Nut, Kep, 4-40	A62X00029-01 2

▲ APPLY ADHESIVE, ITEM 30 ON SHAFT OF ITEM 1
 KEEP ADHESIVE AWAY FROM MOTOR HOUSING
 INSERT ITEM 2 ON MOTOR SHAFT PER DIMENSION
 SHOWN & INSERT 4 SET SCREWS, ITEM 4, INTO
 ITEM 1 TIGHTEN REAR SCREWS & COVER WITH
 ADHESIVE, ITEM 31

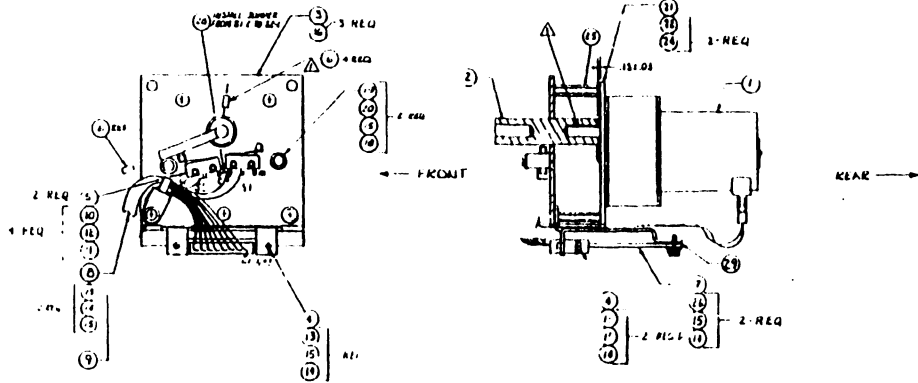

1	MOLO RELEASE		
2	10 0185		
3	REL PWR 100 4117 0		
4	REV PER 100 11 2000		
5	REV PER 100 11 2000		
6	REV PER 100 11 2000		
7	REV PER 100 11 2000		
8	REV PER 100 11 2000		

RELEASED DATE: 2/15/74 BY: [Signature] TITLE: [Signature]	SPEC. NO.: 9102274 REV: 1 DATE: 11/73	TRUMP ASSEMBLY, CARTRIDGE OPENER D 91022274
--	---	---

REF NUMBER	SCH REF NUMBER	NOMENCLATURE	REF PART NUMBER	QTY
		Cartridge Opener Assembly	91D22274(E)	
1		Motor, Cartridge Opener	A35C20042-01	1
2		Shaft, Switch Actuator	B91B22267-01	1
3		Plate, Switch Mounting	B71C21066-01	1
4		Bracket, PCB Mount	A71C21065-01	1
5		Switch, 5A, 250V Unimax 2 LMW-E	A43X01276-01	2
6		Set Screw, Cup Pt., #8-32 x .25 Lg.	A61X00369-01	4
7		PWB Assy, Cartridge Opener	A91C71810-01	1
8		Cable Assy, Cartridge Opener	D91C22275-01	1
9		Cable Tie	A66X01009-01	1
10		Screw, Pan Hd., #2-56 x .44 Lg.	A61X02151-01	4
11		Washer, Flat #2	A63X00104-01	4
12		Washer, Lock #2	A63X00406-01	4
13		Screw, Pan Hd., #4-40 x .44 Lg.	A61X00989-01	4
14		Washer, Flat #4	A63X00627-01	6
15		Washer, Lock #4	A63X00090-01	8
16		Screw, Flat Hd., #8-32 x .38 Lg.	A61X00468-01	3
18		Screw, Pan Hd., #4-40 x .62 Lg.	A61X00991-01	2
19		Spacer, 1/4 O.D. x 3/8 Lg., Smith 8482	A66X01673-01	2
20		Tubing, Rubber 1/4 I.D. x .38 Lg.	A52X00456-01	.07'
21		Plate, Motor Mounting	B71C21082-01	1
22		Screw, Pan Hd., #10-32 x .38 Lg.	A61X01367-01	2
24		Washer, Lock #10	A63X00086-01	2
25		Standoff Hex, 1/4 x .875 Lg. #8-32 Thd.	A66X01672-01	3
26		Screw, Pan Hd., #4-40 x .25 Lg.	A61X01273-01	2
29		Washer, Nylon	A63X00543-01	2

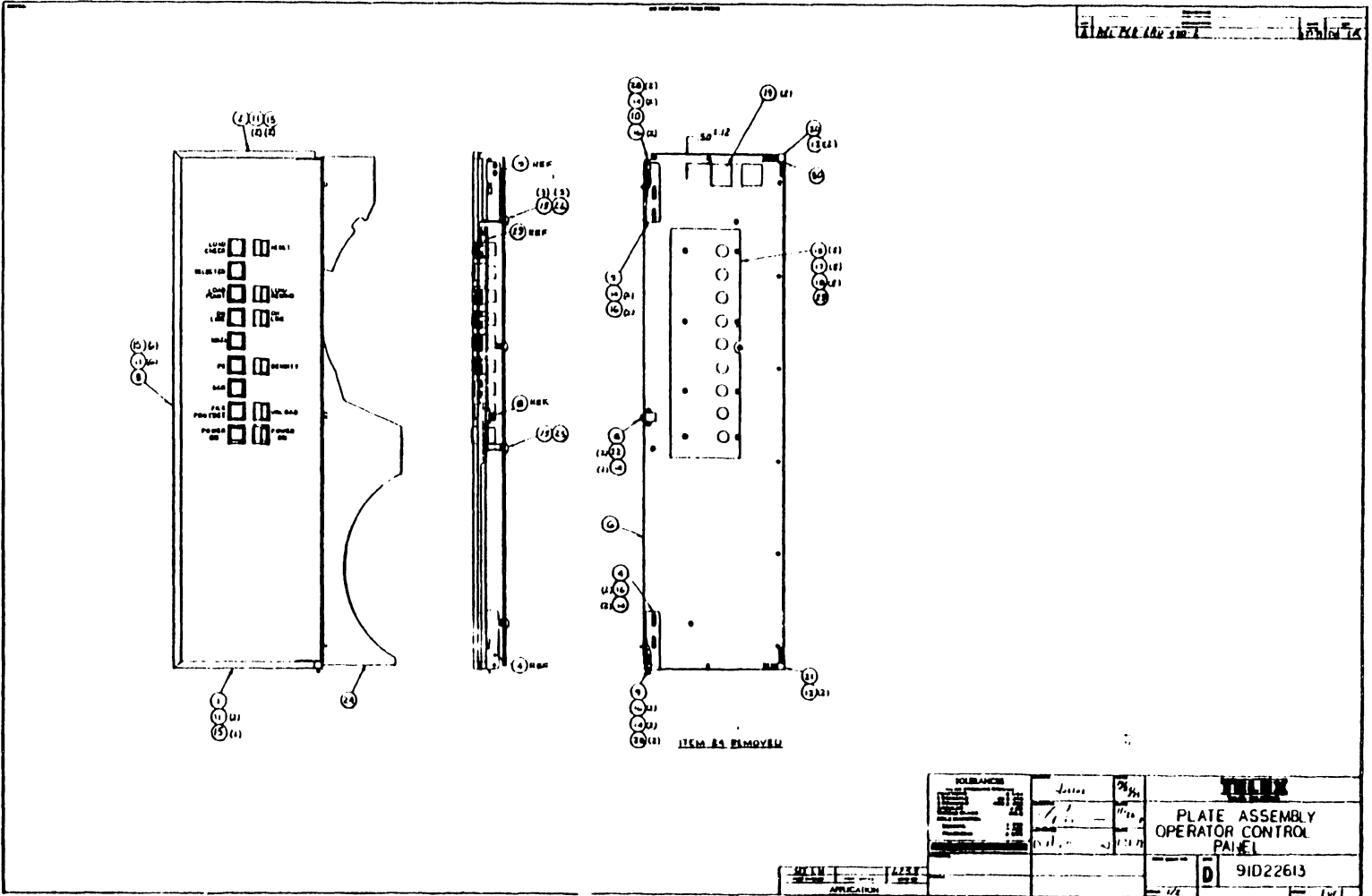

11/24/74

REF NUMBER	SCH REF NUMBER	NOMENCLATURE	REF PART NUMBER	QTY
		Plate Assy. Operator Control Panel	91D22613(B)	
1		Rail, Vacuum Chamber Door	B78C20514-01	1
2		Rail, Vacuum Chamber Door	C78C20515-01	1
3		Rail, Vacuum Chamber Door	B78C20516-01	1
4		Catch Adaptor Assy, Vac. Chamber	B91B22288-01	1
5		Catch Adaptor Assy, Vac. Chamber	B91B22288-02	1
6		Detail Assembly, Operator Control Panel	A91E22597-01	1
8		Nylatch Roller Catch	A66X01685-01	1
9		Pull-Pin, Rel. Hinge (L.H.)	A66X01684-01	1
10		Pull-Pin, Rel. Hinge (R.H.)	A66X01683-01	1
11		Screw, #4-40x0.25 Lg. Pan Hd.	A61X00997-01	10
12		Screw, #4-40x0.31 Lg. Flat Hd.	A61X01954-01	4
13		Screw, #6-32x0.31 Lg. Pan Hd.	A61X01076-01	12
14		Washer, Flat, #4	A63X00300-01	10
15		Washer, Lock, #4	A63X00090-01	10
16		Nut, Kep, #4-40	A62X00029-01	8
17		Washer, Flat, #6	A63X00230-01	8
18		Washer, Lock, #6	A63X00237-01	8
19		Clamp, Flat Cable	A66X01743-01	2
20		Hinge Block, Vacuum Chamber	B73C20113-01	1
21		Hinge Block, Vacuum Chamber	C73C20113-02	1
22		Nut, #4-40 with Nylon Insert	A62X00429-01	2
24		Plate Assembly, Vacuum Chamber	D91D22367-01	1
25		Spring, Vacuum Chamber Plate	A77B20042-01	1
26		Spring, Vacuum Chamber Plate	A77B20042-02	3
28		Screw, #4-40x0.31 Lg. Pan Hd.	A61X00992-01	4
29		PWBA, Operator Control Panel	A91D72204-01	1
30		Washer, Flat #4 Nylon	A63X00707-01	1

SECTION

7

**LOGIC AND
SCHEMATIC
DIAGRAMS**

SCHEMATICS ARE ON THE LAST FICHE IN THE SET

APPENDIX

A & B

DRAWING 92A20646
DATE

6253 REVISION C - RELEASE DLC 11/18/80
6253 MOTHER BOARD INTERCONNECTIONS - FACT

PAGE 1A
REVISION C

NOTES:

1. * INDICATES SOURCE OF SIGNAL.
2. \$ INDICATES POINT OF SIGNAL ON BACKPLANE.
3. @ THIS REPRESENTS A BAR (LOW) SIGNAL.
4. THESE POINTS ARE TIED TOGETHER AND ARE FLOATING AND UNUSED.
5. C1 BACKPLANE +45 VDC SERVO POWER, REFERENCE SYSTEM SCHEMATIC 92020651
6. C1 BACKPLANE -45 VDC SERVO POWER, REFERENCE SYSTEM SCHEMATIC 92020651
7. K1 POWER CONTROL RELAY, REFERENCE SYSTEM SCHEMATIC 92020651
8. L THIS COLUMN IS THE E NUMBERS ON THE BACKPLANE WHICH ARE THE ORIGIN OR TERMINATING POINTS FOR BACKPLANE I/O WIRES THAT ARE NOT WIRE WRAPPED. THIS POINT IS PART OF THE COMPLETE NET AS DEFINED BY THE MNEMONIC IN THE FIRST COLUMN.
9. L THIS COLUMN DESCRIBES THE LEVEL AND TYPE OF INTERCONNECT ITS ASSOCIATED ROW HAS, AS DEFINED BY THE FOLLOWING:
 - BLANK - THERE IS NO INTERCONNECT ASSOCIATED WITH THIS POINT.
 - 0 - THE INTERCONNECT IS BY MEANS OF PRINTED CIRCUIT AND IS AT A LEVEL ZERO.
 - 1 - THE INTERCONNECT IS BY MEANS OF WIRE WRAP AND IS AT A LEVEL ONE.
 - 2 - THE INTERCONNECT IS BY MEANS OF WIRE WRAP AND IS AT A LEVEL TWO.
 - 3 - THE INTERCONNECT IS BY MEANS OF WIRE WRAP AND IS AT A LEVEL THREE. THIS LEVEL IS RESERVED FOR ECR ONLY.
 - W - THE INTERCONNECT IS BY MEANS OF WIRE OTHER THAN WIRE WRAP.
10. PINS ARE COMMON TO NET ONLY WITH CARD INSERTED INTO ITS SLOT.
11. K1-10 & -11 CORRESPOND TO A & B RESPECTIVELY ON RELAY
12. THIS MNEMONIC USED IN 6240/41 CONFIGURATION.
13. USED IN OFM I/O
14. TB1 TERMINAL BOARD
K1 RELAY
J1 PCBA FIX REEL PWR AMP
J2 PCBA FILE REEL PWR AMP
J3 PCBA CASIAN PWR AMP
J4 PCBA REEL PREAMP
J5 PCBA CONTROL LOGIC

DRAWING 92A20646

DATE

6253 REVISION C - RELEASE DLC 11/18/80

6253 MOTHER BOARD INTERCONNECTIONS - FACT

PAGE 2

REVISION C

J6 PCBA PREAMP
J7 PCBA INTERFACE
J8 PCBA WRITE
J9 PCBA AGC & AMP SNS (6253 ONLY) - NOT USED ON 6240/41
J9A PCBA READ #2 (6241/6253) OR AGC & AMP SNS ON 6250
J10 PCBA READ #1
J11 DECK HARNESS
J12 DECK HARNESS
J13 CARTRIDGE OPENER
J14 OPERATOR CONTROL PANEL
J16 PWR SUPPLY - HIGH VOLTAGE
J17 PWR SUPPLY - LOW VOLTAGE

DRAWING 92A20646
DATE

6253 REVISION C - RELEASE DLC 11/18/80
6253 MOTHER BOARD INTERCONNECTIONS - FACT

PAGE 3
REVISION C

SIGNAL NAME	NET	TB1	K1	J1	J2	J3	J4	J5	J6	J7	J8	J9	J9A	J10	J11	J12	J13	J14	J16	J17	NOTE	E	L
+ CAP DR	1					13																	0
+ CAP DR	1					14																	0
+ CAP FDBK	2					15																	0
+ CAP FDBK	2					16			16														0
+12V	3			55	55		3	3	3		3	3	3	3									0
+12V	3			56	56		4	4	4		4	4	4	4									0
+12V	3								3							40					16		0
+12V	3								3							30							1
+12V	3								4							35							1
+12V	3						3										1				15		1
+12V	3										3										16		1
+12V	3								3		4										\$ 5		44
+12V	3								4												\$ 7		45
+45V	4																				\$ 1	C1+	53
+45V	4																				\$ 2	C1+	54
+45V	4																				\$ 3		55
+45V	4			4	4	4																	0
+45V	4			5	5	5																	0
+45V	4			6	6	6																	0
+45V	4			7	7	7																	0
+45V	4			8	8	8																	0
+45V	4			9	9	9																	0
+45V	4			10	10	10																	0
+45V	4			1	1	1																	0
+45V	4			2	2	2																	0
+45V	4			3	3	3																	0
+5V	5						65	65	65	65	65	65	65	65	65	65	65	65	65	65		1	0
+5V	5						66	66	66	66	66	66	66	66	66	66	66	66	66	66			0

XXXXXXXXXXXX OXO
SIGNAL NAME NET TB1 K1 J1 J2 J3 J4 J5 J6 J7 J8 J9 J9A J10 J11 J12 J13 J14 J16 J17 NOTE E L

DRAWING 92A20646
DATE

6253 REVISION C - RELEASE DLC 11/18/80
6253 MOTHER BOARD INTERCONNECTIONS - FACT

PAGE 4
REVISION C

SIGNAL NAME	NET	T01	K1	J1	J2	J3	J4	J5	J6	J7	J8	J9	J9A	J10	J11	J12	J13	J14	J16	J17	NOTE	E	L	
XXXXXXXXXXXX	OXO	OXO	OXO	OXO	OXO	OXO	OXO	OXO	OXO	OXO	OXO	OXO	OXO	OXO	OXO	OXO	OXO	OXO	OXO	OXO	OXO	OXO	OXO	
+5V	5						67	67	67	67	67	67	67	67	3								0	
+5V	5						68	68	68	68	68	68	68	68									0	
+5V	5														11								0	
+5V	5																						0	
+5V	5														13								0	
+5V	5														21								0	
+5V	5														23								0	
+5V	5														31								0	
+5V	5														33								0	
+5V	5						68									4							1	
+5V	5							65								12							1	
+5V	5							66								20							1	
+5V	5							67								31							1	
+5V	5								68							36							1	
+5V	5						65										5				\$ 1	46	W	
+5V	5																						1	
- CAP DR	6					57			\$41												\$ 3	47	W	
- CAP DR	6					58			42														0	
- CAP FDBK	7					55			*39														0	
- CAP FDBK	7					56			40														0	
-12V	8			51	51		5	5	5		5	5	5	5									0	
-12V	8			52	52		6	6	6		6	6	6	6							\$11	43	W	
-12V	8								5							39							1	
-12V	8							5															1	
-12V	8							6								25							1	
-12V	8						5									34			10				1	
-12V	8																				\$ 9	42	W	
K1 COIL B	8		11																			K1-B	23	W
K1 COIL B	8						6																23	W
XXXXXXXXXXXX	OXO	OXO	OXO	OXO	OXO	OXO	OXO	OXO	OXO	OXO	OXO	OXO	OXO	OXO	OXO	OXO	OXO	OXO	OXO	OXO	OXO	OXO	OXO	
SIGNAL NAME	NET	T01	K1	J1	J2	J3	J4	J5	J6	J7	J8	J9	J9A	J10	J11	J12	J13	J14	J16	J17	NOTE	E	L	

DRAWING 92A20646
DATE

6253 REVISION C - RELEASE DLC 11/18/80
6253 MOTHER BOARD INTERCONNECTIONS - FACT

PAGE 5
REVISION C

SIGNAL NAME	NET	T01	K1	J1	J2	J3	J4	J5	J6	J7	J8	J9	J9A	J10	J11	J12	J13	J14	J16	J17	NOTE	E	L		
-45V	9			61	61	61																60	0		
-45V	9			62	62	62																61	0		
-45V	9																				\$ 4	C2-	60	W	
-45V	9																								
-45V	9																					\$ 5	C2-	61	W
-45V	9			63	63	63																\$ 6		62	W
-45V	9																								
-45V	9			64	64	64																			
-45V	9			65	65	65																			
-45V	9			66	66	66																			
-45V	9			67	67	67																			
-45V	9			68	68	68																			
-45V	9			69	69	69																			
-45V	9			70	70	70																			
ADDR 1	10																								
ADDR 2	11									12															
AGC TH	12											7	7	7											
RD TH	12											8	8	8											
RD TH	12																					12			
AMPSNS 1	13									59		57	57	57											
AMPSNS 2	14									57		55	55	55											
AMPSNS 3	15											53	53	53											
AMPSNS 4	16											51	51	51											
AMPSNS 5	17											49	49	49											
AMPSNS 6	18											47	47	47											
AMPSNS 7	19											45	45	45											
AMPSNS 8	20											43	43	43											
AMPSNS 9	21											41	41	41											
BKWRP	22							7	7																
DDT SNS	23							24																	
XXXXXXXXXX	OXO	OXO	OXO	OXO	OXO	OXO	OXO	OXO	OXO	OXO	OXO	OXO	OXO	OXO	OXO	OXO	OXO	OXO	OXO	OXO	OXO	OXO	OXO	OXO	OXO
SIGNAL NAME	NFT	T01	K1	J1	J2	J3	J4	J5	J6	J7	J8	J9	J9A	J10	J11	J12	J13	J14	J16	J17	NOTE	E	L		

DRAWING 92A20646
DATE

6253 REVISION C - RELEASE DLC 11/18/80
6253 MOTHER BOARD INTERCONNECTIONS - FACT

PAGE 6
REVISION C

SIGNAL NAME	NET	T01	K1	J1	J2	J3	J4	J5	J6	J7	J8	J9	J9A	J10	J11	J12	J13	J14	J16	J17	NOTE	E	L
BRKFS 2	24						42	39														0	0
BRKFS 2	24							*39		39												0	1
CAP MTR	25					19			22													40	0
CAP MTR	25						20																0
CAP MTR	25						*21																0
CAP MTR	25						22																0
CAP MTR	25						23																0
CAP MTR	25						24																0
CAP MTR	25						25																0
CAP MTR	25						26																0
CAP MTR	25						27																0
CAP MTR	25						28																0
CAP MTR	25	13																				40	W
CAP MTR R1N	26						*43															41	0
CAP MTR R1N	26						44																0
CAP MTR R1N	26						45																0
CAP MTR R1N	26						46																0
CAP MTR R1N	26						47																0
CAP MTR R1N	26						48																0
CAP MTR R1N	26						49																0
CAP MTR R1N	26						50																0
CAP MTR R1N	26						51																0
CAP MTR R1N	26						52																0
CAP MTR R1N	26	14																				41	W
CL TK 1	27										62	62	62										0
PREAMP 1	27											62	62								12		0
CL TK 2	28										58	58	58										0
PREAMP 2	28											58	58										0
CL TK 3	29										54	54	54										0
PREAMP 3	29											54	54										0
XXXXXXXXXXXX	OXO	OXO	OXO	OXO	OXO	OXO	OXO	OXO	OXO	OXO	OXO	OXO	OXO	OXO	OXO	OXO	OXO	OXO	OXO	OXO	OXO	OXO	OXO
SIGNAL NAME	NET	T01	K1	J1	J2	J3	J4	J5	J6	J7	J8	J9	J9A	J10	J11	J12	J13	J14	J16	J17	NOTE	E	L

DATE

6253 MOTHER BOARD INTERCONNECTIONS - FACT

REVISION C

SIGNAL NAME	NET	J01	K1	J1	J2	J3	J4	J5	J6	J7	J8	J9	J9A	J10	J11	J12	J13	J14	J16	J17	NOTE	F	L
PREAMP 9	95												25	25							12	0	
GN BIT 5	96												*23	23								0	
GN BIT 6	97												*17	17								0	
GN BIT 6	97								18	18	18											0	
GRD (LOGIC)	98				1	1	1	1	1	1	1	1	1	1	2							0	
GRD (LOGIC)	98														4							0	
GRD (LOGIC)	98				69	69	69	69	69	69	69	69	69	69								0	
GRD (LOGIC)	98				70	70	70	70	70	70	70	70	70	70								0	
GRD (LOGIC)	98														12							0	
GRD (LOGIC)	98														14							0	
GRD (LOGIC)	98														22							0	
GRD (LOGIC)	98																7					1	
GRD (LOGIC)	98																					1	
GRD (LOGIC)	98																					1	
GRD (LOGIC)	98																					1	
GRD (LOGIC)	98																					1	
GRD (LOGIC)	98																					0	
GRD (LOGIC)	98																					0	
GRD (LOGIC)	98																					0	
GRD (LOGIC)	98																					1	
GRD (LOGIC)	98																					1	
GRD (LOGIC)	98																					1	
GRD (LOGIC)	98																					1	
GRD (LOGIC)	98																					1	
GRD (LOGIC)	98																					1	
GRD (LOGIC)	98																					1	
GRD (LOGIC)	98																					1	
GRD (LOGIC)	98																					1	
GRD (LOGIC)	98																					1	
GRD (LOGIC)	98																					1	
GRD (LOGIC)	98																					1	
GRD (LOGIC)	98																					1	
GRD (LOGIC)	98																					1	
GRD (LOGIC)	98																					1	
GRD (LOGIC)	98																					1	
GRD (LOGIC)	98																					1	
GRD (LOGIC)	98																					1	
GRD (LOGIC)	98																					1	
GRD (LOGIC)	98																					1	
GRD (LOGIC)	98																					1	
GRD (LOGIC)	98																					1	
GRD (LOGIC)	98																					1	
GRD (LOGIC)	98																					1	
GRD (LOGIC)	98																					1	
GRD (LOGIC)	98																					1	
GRD (LOGIC)	98																					1	
GRD (LOGIC)	98																					1	
GRD (LOGIC)	98																					1	
GRD (LOGIC)	98																					1	
GRD (LOGIC)	98																					1	
GRD (LOGIC)	98																					1	
GRD (LOGIC)	98																					1	
GRD (LOGIC)	98																					1	
GRD (LOGIC)	98																					1	
GRD (LOGIC)	98																					1	
GRD (LOGIC)	98																					1	
GRD (LOGIC)	98																					1	
GRD (LOGIC)	98																					1	
GRD (LOGIC)	98																					1	
GRD (LOGIC)	98																					1	
GRD (LOGIC)	98																					1	
GRD (LOGIC)	98																					1	
GRD (LOGIC)	98																					1	
GRD (LOGIC)	98																					1	
GRD (LOGIC)	98																					1	
GRD (LOGIC)	98																					1	
GRD (LOGIC)	98																					1	
GRD (LOGIC)	98																					1	
GRD (LOGIC)	98																					1	
GRD (LOGIC)	98																					1	
GRD (LOGIC)	98																					1	
GRD (LOGIC)	98																					1	
GRD (LOGIC)	98																					1	
GRD (LOGIC)	98																					1	
GRD (LOGIC)	98																					1	
GRD (LOGIC)	98																					1	
GRD (LOGIC)	98																					1	
GRD (LOGIC)	98																					1	
GRD (LOGIC)	98																					1	
GRD (LOGIC)	98																					1	
GRD (LOGIC)	98																					1	
GRD (LOGIC)	98																					1	
GRD (LOGIC)	98																					1	
GRD (LOGIC)	98																					1	
GRD (LOGIC)	98																					1	
GRD (LOGIC)	98																						

DRAWING 92A20646

6253 REVISION C - RELEASE DLC 11/18/80

PAGE 13

DATE

6253 MOTHER BOARD INTERCONNECTIONS - FACT

REVISION C

SIGNAL NAME	N11	TB1	K1	J1	J2	J3	J4	J5	J6	J7	J8	J9	J9A	J10	J11	J12	J13	J14	J16	J17	NOTE	E	L		
GRD (LOGIC)	98													1											
GRD (LOGIC)	98													2											
K1 COIL A	98		10																			K1-A	22	W	
K1 COIL A	98							2															22	0	
GRD (SERVO)	99																						22	0	
GRD (SERVO)	99																						7	W	
GRD (SERVO)	99																						8	W	
GRD (SERVO)	99																								
GRD (SERVO)	99																						9	W	
GRD (SERVO)	99																						10	W	
GRD (SERVO)	99				35	35	35																		
GRD (SERVO)	99				36	36	36																		
GRD (SERVO)	99				37	37	37																		
GRD (SERVO)	99				38	38	38																		
GRD (SERVO)	99				39	39	39																		
GRD (SERVO)	99				40	40	40																		
GRD (SERVO)	99				31	31	31	+17																	
GRD (SERVO)	99				32	32	32	18																	
GRD (SERVO)	99				33	33	33	+59																	
GRD (SERVO)	99				34	34	34	60																	
HS RFW	100							*27	27																
HUB VAC SW	101							44																	
IL	102							*40	48	50															
IL	102							48																	
INITARA	103									*64	63	63	63												
UNED	104							*32															9		
K1 RELAY 7	105	3	7																				C1	5	
LD CHK	106							*8	27																
LD FLT IND	107							*17																	
LD/REW PB	108																								
LDPT	109							*54																	
LDPT IND	110							*47	19																
XXXXXXXXXX	OXO	OXO	OXO	OXO	OXO	OXO	OXO	OXO	OXO	OXO	OXO	OXO	OXO	OXO	OXO	OXO	OXO	OXO	OXO	OXO	OXO	OXO	OXO	OXO	
SIGNAL NAME	HFT	TB1	K1	J1	J2	J3	J4	J5	J6	J7	J8	J9	J9A	J10	J11	J12	J13	J14	J16	J17	NOTE	E	L		

DRAWING 92A20646

6253 REVISION C - RELEASE DLC 11/18/80

PAGE 14

DATE

6253 MOTHER BOARD INTERCONNECTIONS - FACT

REVISION C

SIGNAL NAME	NFI	I1	K1	J1	J2	J3	J4	J5	J6	J7	J8	J9	J9A	J10	J11	J12	J13	J14	J16	J17	NOTE	E	L
XXXXXXXXXX	OXO	OXO	OXO	OXO	OXO	OXO	OXO	OXO	OXO	OXO	OXO	OXO	OXO	OXO	OXO	OXO	OXO	OXO	OXO	OXO	OXO	OXO	OXO
LDPT1 2	111													42	42	42							0
LDPT1 3	111							45						42									1
LEOT	112							*51	22														1
LOW PACK 2	113							39															1
LRTH 2	114									30				19	19	19				\$ 1			0
LRTH 2	114													20	20	20							0
LSPD	115																						0
MNRL SW 2	116							63	*59	44													0
ALTDENS 2	117								64	14	13	13	13	13						\$18			0
NRZI 2	117								64	*14	13	13	13	13									0
NRZI INO 2	118									*4													0
OCP +5V	119																				22		0
																					6		68
OCP +5V	119																						0
ONL	120																				14		68
ONL HST 2	121							*33		33													0
										61													1
ONLN PB	122																						1
OPN CART 2	123							10															1
OVR TH 1 2	124							*53															1
														64	64	64							0
PREFAMP 1	124																						0
OVR TH 2 2	125																						0
PREFAMP 2	125													60	60	60							0
														60	60	60							0
OVR TH 3 2	126																						0
PREFAMP 3	126													56	56	56							0
OVR TH 4 2	127													52	52	52							0
																							0
PREFAMP 4	127																						0
OVR TH 5 2	128													48	52	52							0
PREFAMP 5	128													48	48	48							0
														48	48	48							0
OVR TH 6 2	129																						0
OVR TH 7 2	130													44	44	44							0
PREFAMP 6	130													39	39	39							0
														39	39	39							0
XXXXXXXXXX	OXO	OXO	OXO	OXO	OXO	OXO	OXO	OXO	OXO	OXO	OXO	OXO	OXO	OXO	OXO	OXO	OXO	OXO	OXO	OXO	OXO	OXO	OXO
SIGNAL NAME	NFI	TB1	K1	J1	J2	J3	J4	J5	J6	J7	J8	J9	J9A	J10	J11	J12	J13	J14	J16	J17	NOTE	E	L

DRAWING 92A20646
DATE

6253 REVISION C - RELEASE DLC 11/18/80
6253 MOTHER BOARD INTERCONNECTIONS - FACT

PAGE 16
REVISION C

SIGNAL NAME	NFT	T01	K1	J1	J2	J3	J4	J5	J6	J7	J8	J9	J9A	J10	J11	J12	J13	J14	J16	J17	NOTE	E	L		
RT 9	155									24		24	24	24									0		
RWG	156							+35		15													1		
SAGCHK @	157									63		61	61	61									0		
SEL IND @	158							+56								17							1		
OPQUT @	159									+41													0		
SLCT @	159							40		+41											13		0		
SPARE0	160									3												4	1		
SPARE1	161									6												4	1		
TACH +	162								56														63	0	
TACH -	163	+15																					63	W	
TACH -	163	+16							60														65	W	
TACH PLS @	164									+9	18													0	
TACH SHLD	165									+58													64	0	
TACH SHLD	165	17																					64	W	
IHRD @	166							28	+57															0	
ISTR EN @	167								+12															0	
ISTR EN @	167										9													0	
UNLD PB @	168								34															1	
URDY @	169								+11	11														0	
VAC MTR @	170								+41															67	0
VAC MTR @	170																							67	W
WE 1 @	171								42	17														0	
WE 1 @	171								42															1	
WE 2 @	172																							1	
WE 2 @	172																							0	
WPON @	173								26	21	21													0	
WPON @	173																							0	
WRAP @	174							30	+61															1	
WRT STAT @	175																							0	
XXXXXXXXXX	OXO	OXO	OXO	OXO	OXO	OXO	OXO	OXO	OXO	OXO	OXO	OXO	OXO	OXO	OXO	OXO	OXO	OXO	OXO	OXO	OXO	OXO	OXO	OXO	
SIGNAL NAME	NFT	T01	K1	J1	J2	J3	J4	J5	J6	J7	J8	J9	J9A	J10	J11	J12	J13	J14	J16	J17	NOTE	E	L		

DRAWING 92A20646
DATE

6253 REVISION C - RELEASE DLC 11/18/80
6253 MOTHER BOARD INTERCONNECTIONS - FACT

PAGE 17
REVISION C

SIGNAL NAME	NET	T01	K1	J1	J2	J3	J4	J5	J6	J7	J8	J9	J9A	J10	J11	J12	J13	J14	J16	J17	NOTE	E	L
WRT STAT @	175																						
WT 1	176									+62	61	16	16	16									0
WT 1	176										62												0
WT 2	177									+60	59												0
WT 2	177										60												0
WT 3	178									+58	57												0
WT 3	178										58												0
WT 4	179									+56	55												0
WT 4	179										56												0
WT 5	180									+54	53												0
WT 5	180										54												0
WT 6	181									+52	51												0
WT 6	181										52												0
WT 7	182									+50	49												0
WT 7	182										50												0
WT 8	183									+48	47												0
WT 8	183										48												0
WT 9	184									+46	45												0
WT 9	184										46												0
12 VAC	185								9														0
12 VAC	185																			15			66 0
FWD HIICH @	186																						0
TSPT 1	187																						9
TSPT 2	188																						9
K1 RELAY 9	189	9	9																				C2 13 W

XXXXXXXXXX OXO
SIGNAL NAME NET T01 K1 J1 J2 J3 J4 J5 J6 J7 J8 J9 J9A J10 J11 J12 J13 J14 J16 J17 NOTE E L

This drawing and specifications, herein, are the property of POWER-ONE INC and shall not be reproduced or copied or used in whole or in part as the basis for the manufacture or sale of items without written permission.

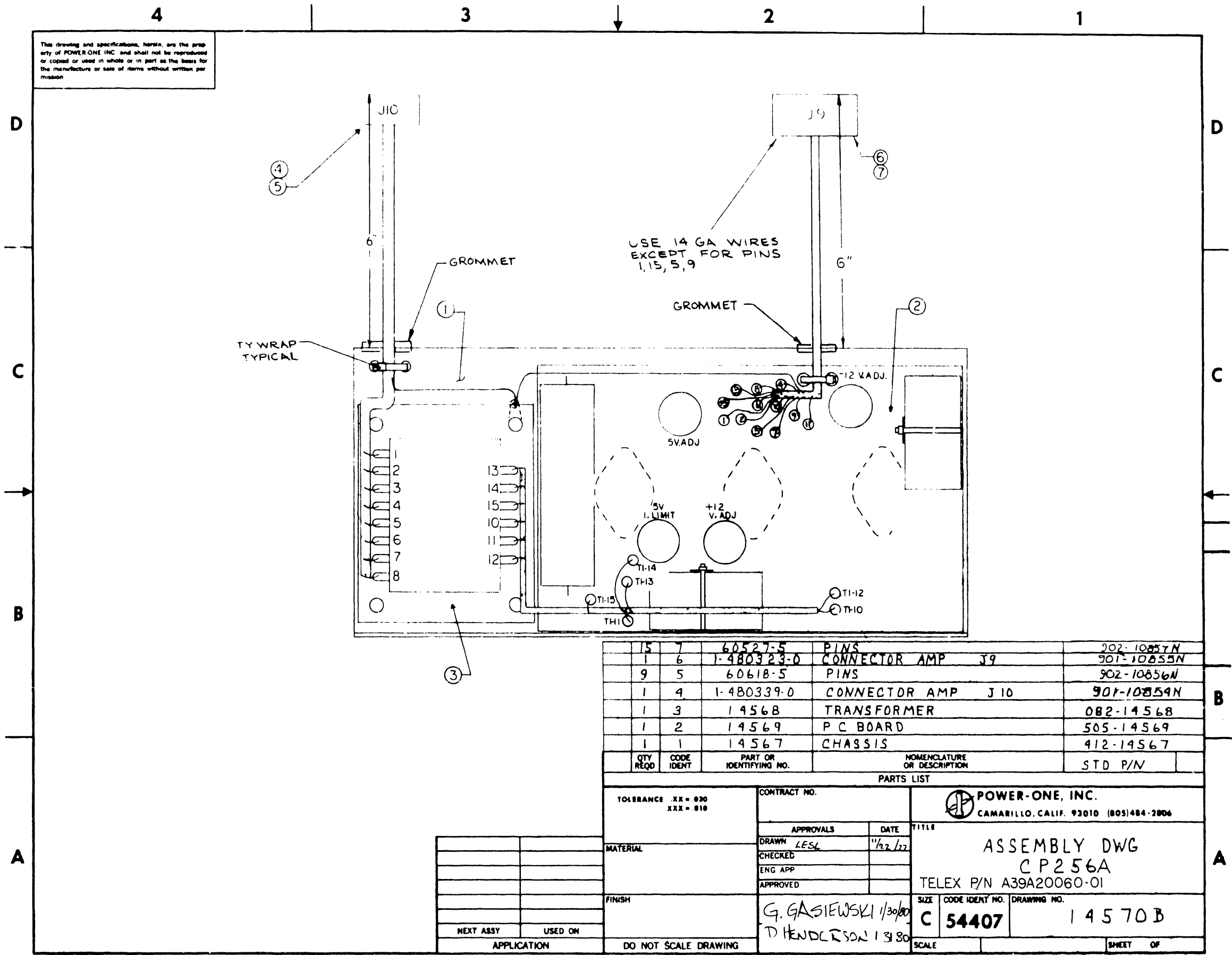

15	7	60527-5	PINS	902-10857N
1	6	1-480323-0	CONNECTOR AMP J9	901-10855N
9	5	60618-5	PINS	902-10856N
1	4	1-480339-0	CONNECTOR AMP J10	901-10854N
1	3	14568	TRANSFORMER	082-14568
1	2	14569	P C BOARD	505-14569
1	1	14567	CHASSIS	412-14567
QTY REQD	CODE IDENT	PART OR IDENTIFYING NO.	NOMENCLATURE OR DESCRIPTION	STD P/N

TOLERANCE .XX = .030 XXX = .010		CONTRACT NO.		POWER-ONE, INC. CAMARILLO, CALIF. 93010 (805)484-2806	
MATERIAL		APPROVALS	DATE	TITLE	
FINISH		DRAWN LESL	11/22/77	ASSEMBLY DWG CP256A	
NEXT ASSY		CHECKED		TELEX P/N A39A20060-01	
USED ON		ENG APP		SIZE	CODE IDENT NO. DRAWING NO.
APPLICATION		APPROVED		C	54407 14570B
DO NOT SCALE DRAWING		G. GASIEWSKI 1/30/80 D. HENDERSON 1/31/80		SCALE	SHEET OF

This drawing and specifications, herein, are the property of POWER ONE INC. and shall not be reproduced or copied or used in whole or in part on the basis of the information or data of these without written permission.

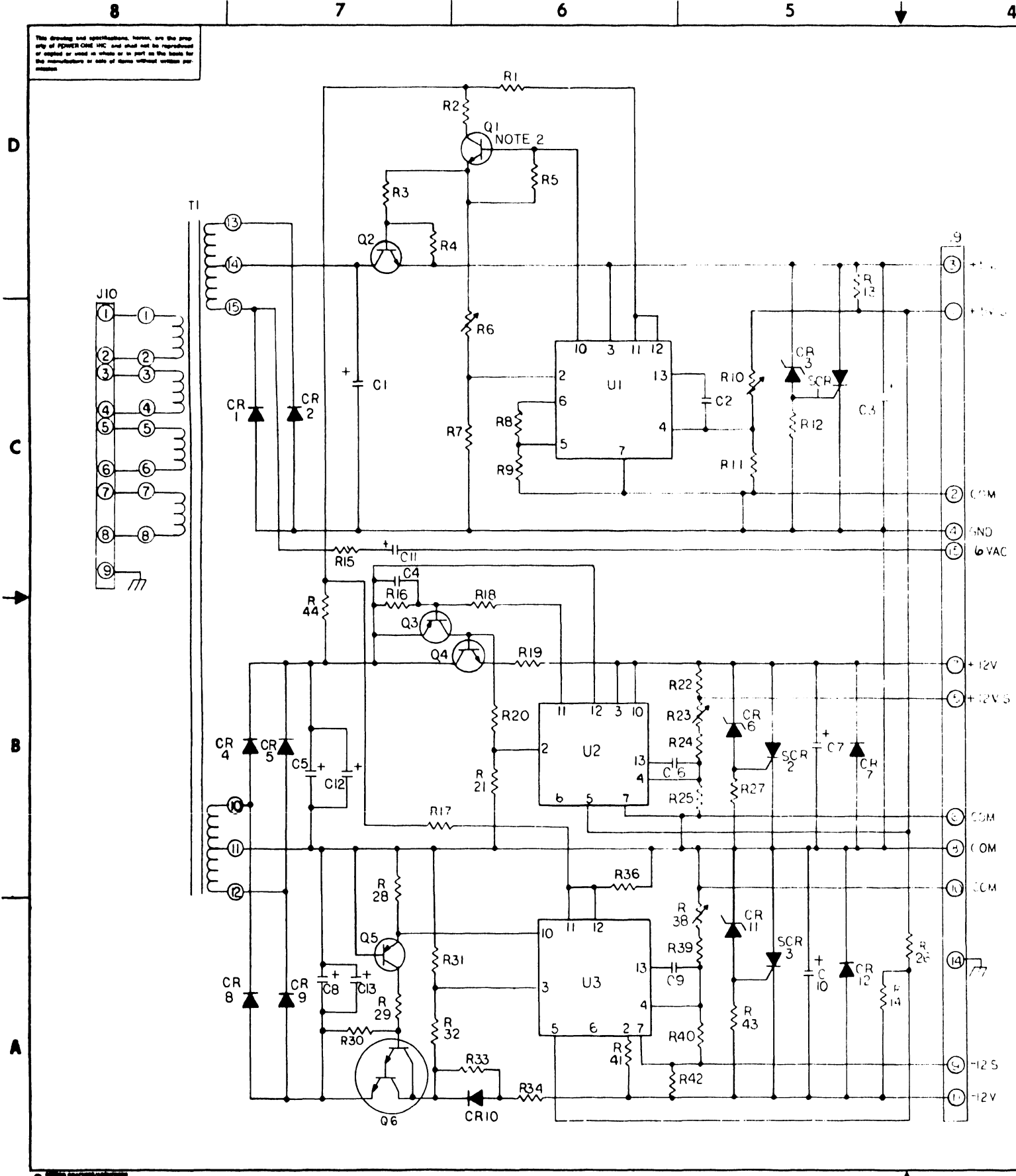

NOTES:
 1 USE IC SOCKETS FOR U1, U2, & U3.
 2 HEATSINK WITH 13920.
 3 C5, C12 AND C8, C13 USE 2 CLAMPS AND ONE TYPICAL WRAP BOTTOM HALF OF CLAMP TO FACE INSIDE OF BOARD. CLAMP WILL NOT FIT BETWEEN BOARD AND S/M.

REF DES	PART OR IDENTIFYING NO.	DESCRIPTION	STANDARD PART NO.
C1	10000/5	CAPACITOR ALUM.ELECT	02-0096
C2	100/35	ALUM.ELECT	10-0107
C3, 8, 12, 13	3300/35		02-0099
C4, 10	100/35		101-0110
C5	10000/100	MYLAR	104-10092
C6	101/100	CAPACITOR MYLAR	04-10095
C7	0.1/50	CAPACITOR MYLAR	104-10094
CR1, 2	MR750	DIODE	111-10256
CR3	1N753A		112-10006
CR4, 5, 9, 10	AE5B		112-10252
CR6, 11	1N458		112-10009
CR7, 12	AE1C	DIODE	112-10251
C11	10/25	CAPACITOR	101-10114
Q1	2N6551	TRANSISTOR	72-0249
Q2	12505-2		7-0262
Q3	12500-3		7-0261
Q4	2N6554		172-0250
Q5	2N2907A		72-0248
Q6	2N6055	TRANSISTOR	71-10263
SCR1	5050BLS3	SCR	60-0013
SCR2, 3	5030BLS3	SCR	120-10258
U1, 2, 3	uLc 723	IC VOLTAGE REGULATOR	130-10287
R1, 15	45K	RESISTOR	151-10380
R2, 4	82K	RESISTOR 1/2 W 5% CF	151-10339
R11, 14	2K	RESISTOR 1/2 W 2% MF	152-10511
R7	3.9K		151-10379
R8, 9, 5	2.2K		151-10373
R20	4.70K		151-10357
R3, 3	2.7K		151-10305
R10	1K		151-10365
R1, 7, 8, 4, 27	330K		151-10353
R28, 29, 43	330K		151-10353
R30, 31	4.7K		151-10381
R13, 12	6.8K		151-10313
R22, 42	6.8K		151-10313
R32	2.7K		151-10351
R36	1.6K	5% CF	151-10370
R40	4.7K	1/2W 2% MF	152-10521
R24	1.2K	1/2W 2% MF	152-10527
R19, 34	0.22K	RESISTOR 2W WW BWH	158-10079
R26, 37	27K	RESISTOR 1/2W 2% MF	152-10515
R40, 23, 38	1.5K	POTENTIOMETER	155-10085
R25	1.6K	RESISTOR 1/2W 2% MF	152-10510
T1	14568	TRANSFORMER	082-14568
PCB	14569	PRINTED CIRCUIT BOARD	505-14569
CHASSIS	14567	CHASSIS-ALUM	412-4567

TOLERANCE XX-030 XXX-010		CONTRACT NO.		POWER-ONE INC 331 DAWSON DRIVE CAMARILLO CALIF 93010 805-484-2806	
MATERIAL		APPROVALS	DATE	TITLE	
FINISH		DRAWN	3/2/80	SCHEMATIC	
NEXT ASSY		CHECKED		CP256A	
USED ON		ENG APP		TELEX P/N 439A2006J-01	
APPLICATION		APPROVED	4/2/80	SIZE	CODE IDENT NO
DO NOT SCALE DRAWING		G. GASIEWICZ	1/29/80	D	54407
		D. HENDERSON	1/31/80	DRAWING NO	14566
				SCALE	SHEET OF

**APPENDIX
C
VS AB TAPE SWITCH
TELEX
CONFIGURATION**

APPENDIX C

MODEL 7092 VS AB TAPE SWITCH

2219V/2248V TELEX TAPE DRIVE CONFIGURATION

TABLE OF CONTENTS

1.0 Introduction.....	C-1
2.0 Controls and Indicators.....	C-2
3.0 Operation.....	C-3
4.0 Parts Replacement.....	C-4
4.1 Cover Removal Procedure.....	C-4
4.2 AB Tape Switch PCA (210-9181) Removal Procedure.....	C-5
4.3 Power Supply (WLI 725-2850) Removal Procedure.....	C-6
5.0 Installation.....	C-7
5.1 Installation Using Telex Tape Drive Configuration.....	C-7
5.2 Installation Procedures for Model 7092-KIT-1.....	C-8
5.3 VS 300/7000 Telex Tape Drive Connectors.....	C-9
6.0 Field Replaceable Units (FRUs) Listed By Wang Part Number..	C-10
7.0 Specifications.....	C-11

1.0 INTRODUCTION

The Model 7092 VS Tape AB Switch is an electronic tape drive switch that allows switching a 2219V/2248V Telex Tape drive between any combination of two Wang VS 85/100, 300, or 7000 series CPUs. The switch allows switching to an alternate or backup VS system with a minimum of delay. In addition, the unit allows sharing a tape drive between two VS systems. The switch can be activated remotely at a distance of up to 1000 feet. (Note that the switch must be in the "A" position to be activated remotely.)

An installation cable kit is available for the 2219V/2248V Telex tape drive (7092-KIT-1).

An optional Key Switch (Model 7090-KS, WLI 289-0974) is a small plastic box with a two position key switch and a BNC connector that may be used for remote switching, up to a distance of 1000 feet. A 25' BNC-BNC Coax Cable (WLI 220-0356) is the standard cable provided with the 7090-KS.

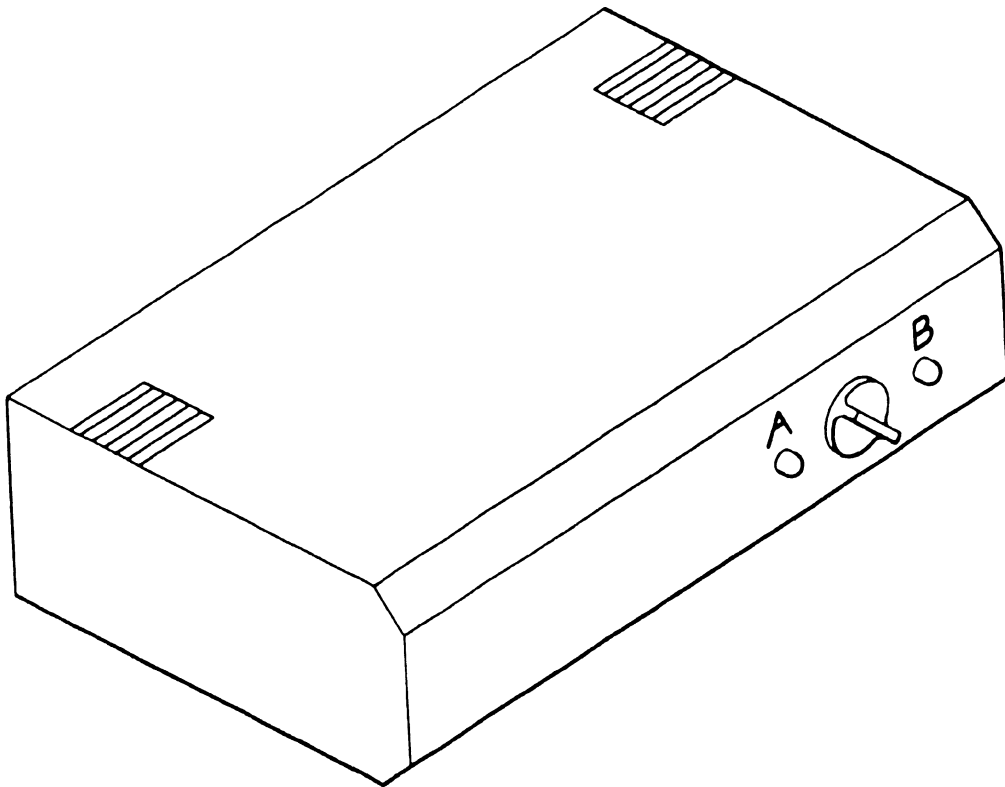

Figure 1. Model 7092 Tape AB Switch Box

2.0 CONTROLS AND INDICATORS

The Model 7092 consists of a switch assembly box (Figure 2), enclosing a 210-9181 PCB and Power Supply, on the front of which is a key switch and two LEDs, labeled "A" and "B" positioned on either side of the keyswitch. When an LED is on, it indicates the CPU which has been selected.

On the rear panel of the Model 7092 (Figure 3) is a voltage selection switch (110/220 VAC), Power ON/OFF switch, two BNC connectors for remote or daisy chain of the switch control, AC Power Cord input connector and nine connectors (three each for CPU A, CPU B and Tape Drive).

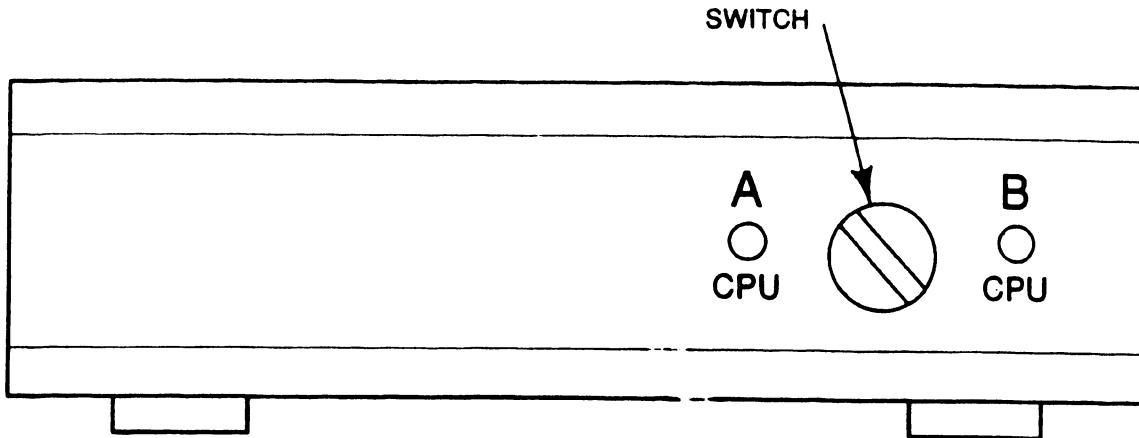

Figure 2. Front View Controls and Indicators

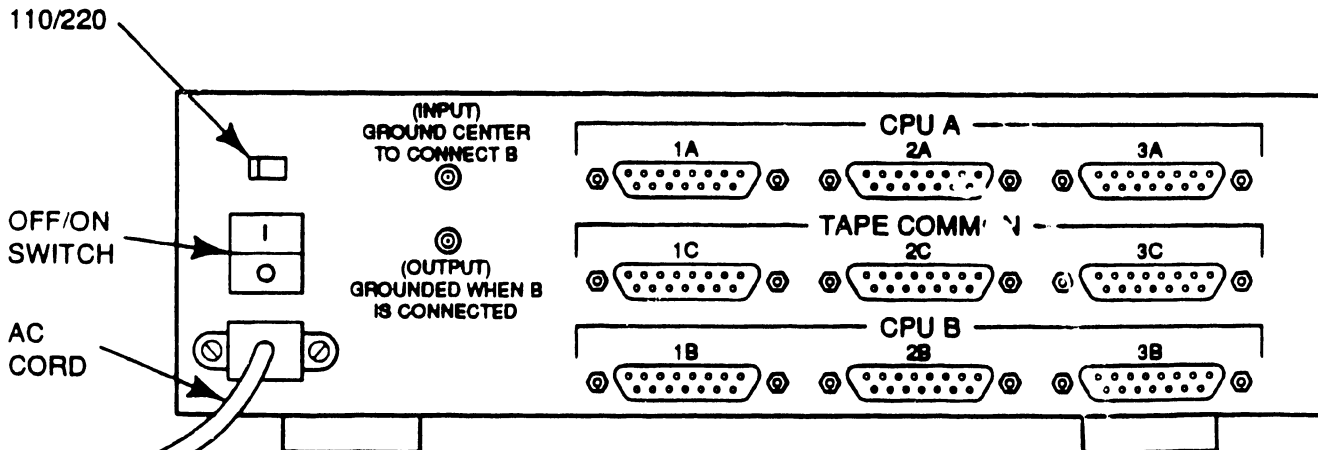

Figure 3. Rear View Controls and Indicators

3.0 OPERATION

A keyswitch located on the front panel of the Model 7092 VS Tape AB switch allows electronic switching of the tape drive between two VS Systems. Two LEDs, positioned on either side of the keyswitch, are labeled "A" and "B"; the LED that is on indicates which CPU has been selected. (Figure 4).

CAUTION

Do not switch between the two CPUs while the tape drive is performing I/O operations. Switching while the drive is operating could result in the loss or damage of information on the tape. Before making any CPU selections, stop the tape drive, then select the CPU that you want to use with the tape drive.

An optional Key Switch (7090-KS) is a small plastic box with a two position key switch and a BNC connector that may be used for remote switching, up to a distance of 1000 feet. A 25' BNC-BNC Coax Cable (WLI 220-0356) is the standard cable provided with the 7090-KS.

NOTE

Switch must be in the "A" position to be activated remotely.

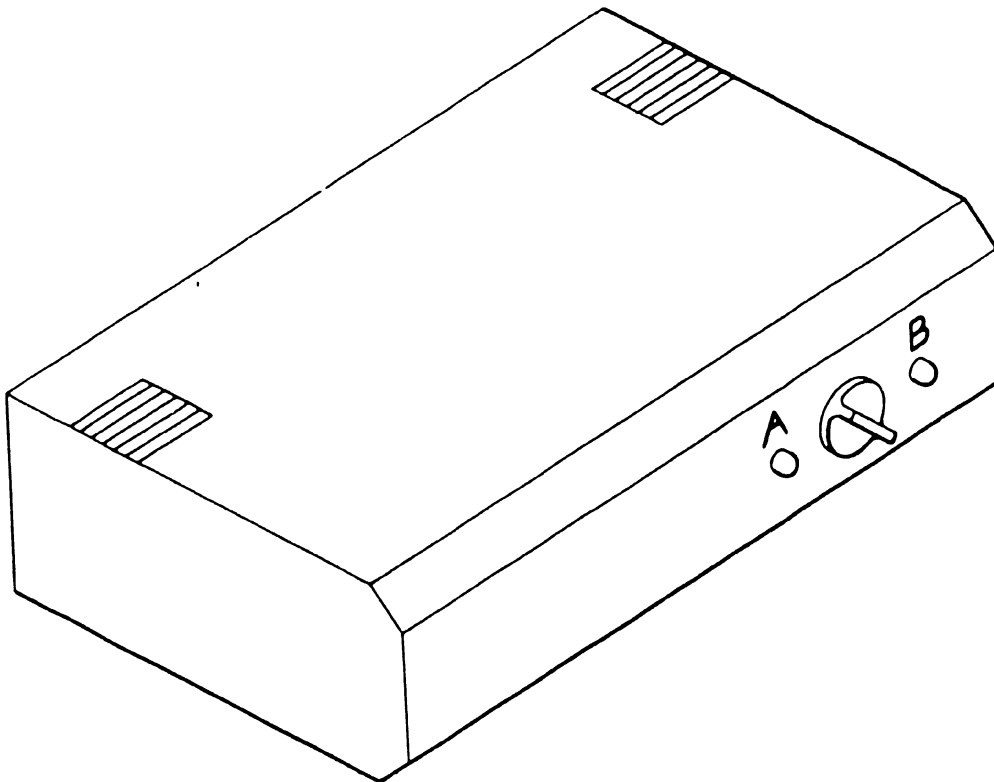

Figure 4. Model 7092 Tape AB Switch Box

4.0 PARTS REPLACEMENT

4.1 Cover Removal Procedure

1. Remove six Phillips screws from rear of unit. Two each from outside edges, and two from top of rear panel. (Figure 5)
2. Push cover forward approximately two inches to disengage it from bottom clamps.
3. Once cover is freed from unit, stand cover on front edge and disconnect key switch cable (WLI 220-2101) from connector J10 on AB Tape Switch PCA (WLI 210-9181). (Figure 6)

NOTE

The key switch cable is not keyed. Pin 1 is the light brown wire.

4. Cover may now be removed from unit.

Reverse removal procedure to replace cover.

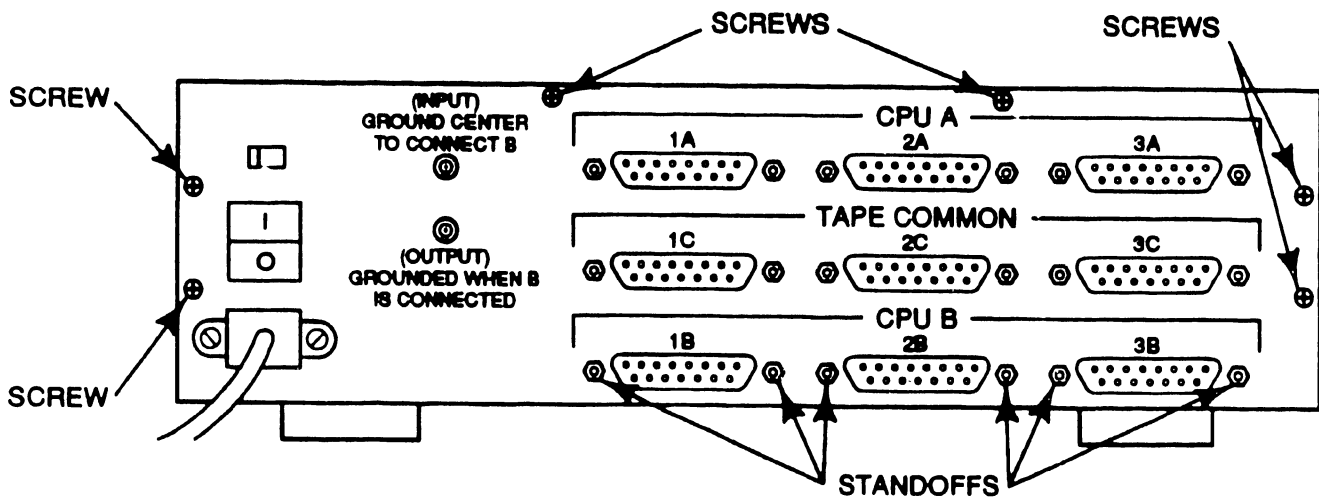

Figure 5 Cover Removal Procedure

4.0 PARTS REPLACEMENT (Cont.)

4.2 AB Tape Switch PCA (210-9181) Removal Procedure

1. Remove cover and disconnect key switch cable from connector J10 on 210-9181 PCA. (Paragraph 4.1)
2. Disconnect two-pin plug from connector J11 on 210-9181 PCA. Plug is keyed +5V (red wire) and Ground (black wire). (Figure 6)
3. Disconnect four-pin plug for remote coax connectors from J12 on 210-9181 PCA.
4. Disconnect cable (220-3506) between rear panel connectors 3A, 2A and 1A and connectors J1, J2 and J3 on the 210-9181 PCA. (Pin 1 is Red).
5. Disconnect cable (220-3506) between rear panel connectors 3C, 2C and 1C and connectors J4, J5 and J6 on the 210-9181 PCA. (Pin 1 is Red).
6. Remove six one-quarter inch standoffs from rear panel connectors 3B, 2B and 1B. (Figure 5)
7. Remove five Phillips screws from top of 210-9181 PCA and remove from unit.

Reverse removal procedure to replace AB Tape Switch PCA (210-9181).

WARNING

On revision 0 artwork (210-9181-0), nylon washers were used to insulate top and bottom etches near the two center screws. These washers were located near locations J5 and J5. Ensure these washers are replaced when replacing a 210-9181 PCA on any early unit. This problem was corrected with revision 1 artwork (210-9181-1). Only artwork revisions 1 and above should be in the field.

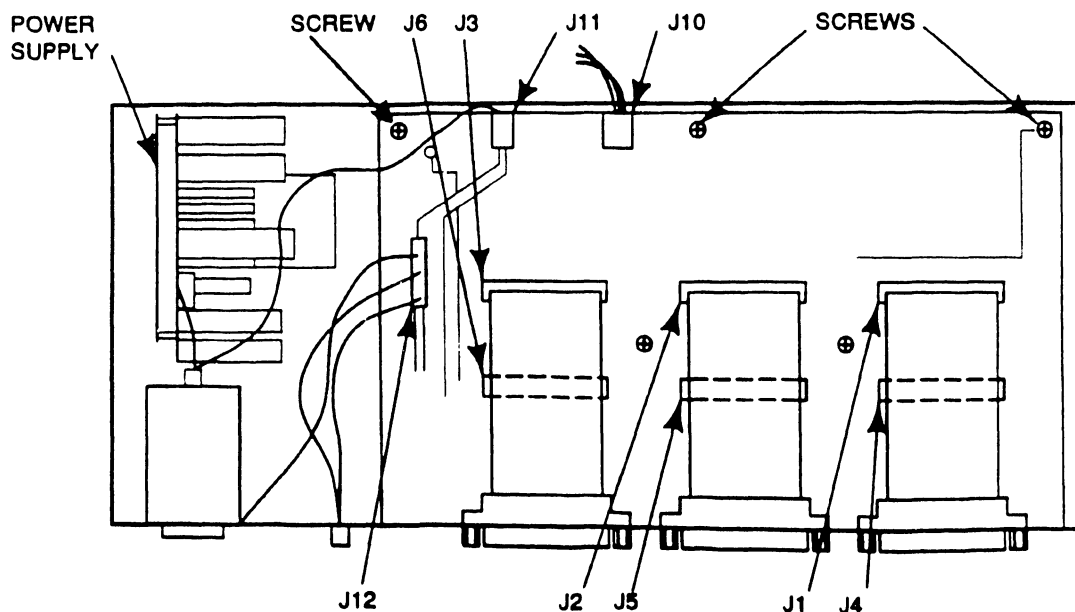

Figure 6 210-9181 PCA Removal Procedure

4.0 PARTS REPLACEMENT (Cont.)

4.3 Power Supply (WLI 725-2850) Removal Procedure

NOTE

Before removing power supply for failure, check fuse on power supply PCB. Fuse ratings: 115V - 1.0 Amp (50/60 Hz), 230V - 0.5 Amp (50/60 Hz).

1. Power off VS AB Tape Switch unit.
2. Remove Cover from unit. (Paragraph 4.1)
3. Disconnect (pull off) white wire from ON/OFF switch to power supply PCB from pin labeled 230V. (Black and white wires are in clear plastic tubing from line filter). (Figure 7)
4. Disconnect single black wire from pin labeled 115V on power supply PCB. (Black and white wires are in clear plastic tubing from line filter). (Figure 7)
5. Disconnect three-pin cable, with brown top wire and blue bottom wire, from power supply PCB.
6. Disconnect (pull off) frame ground (light green single wire) from upper left corner of power supply PCB.
7. Disconnect +5V cable (Red and Black) from connector J4 of power supply PCB. (Other end of cable connects to J11 on 210-9181 PCA).
8. Disconnect keyed plug with resistor from connector J6 of power supply PCB.
9. Remove four Phillips screws, one from each corner of the power supply PCB.

Reverse removal procedure to replace power supply.

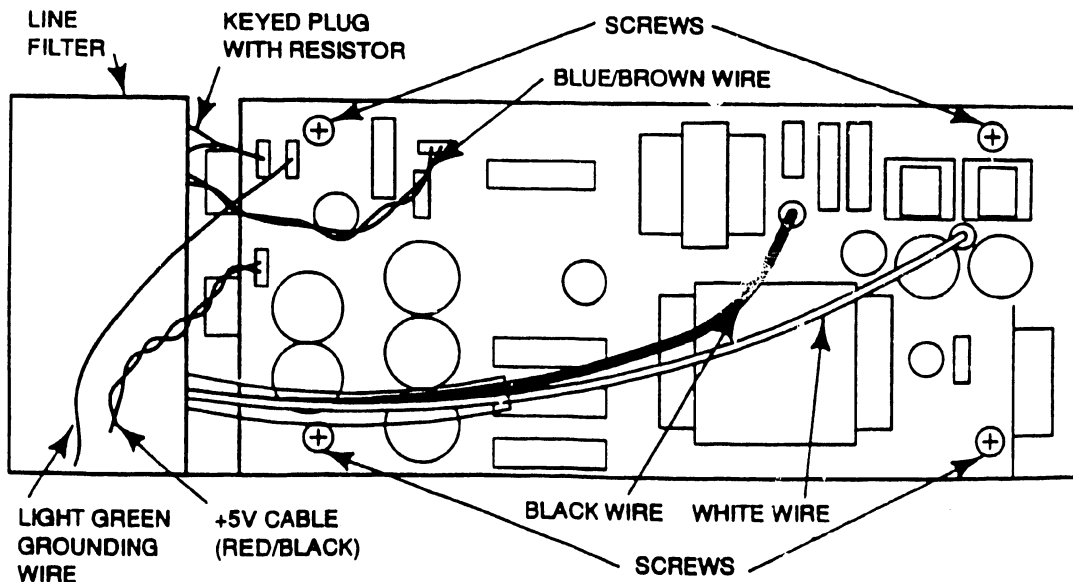

Figure 7 Power Supply Removal Procedure

5.0 INSTALLATION

5.1 Installation Using Telex Tape Drive Configuration

When used with the Telex Model 2219V/2248V tape drives, each of the VS systems is connected to the tape drive switch by 3 I/O cables. (A total of 9 cables are supplied with the installation kit.)

NOTE

Each VS system must have a 2219V/2248V tape drive Input/Output Processor (IOP) installed in order for the Model 7092 Tape Drive Switch to operate. The VS 85/100 requires a 22V15-2 IOP, and the VS 300/7000 requires a 23V95-2 IOC.

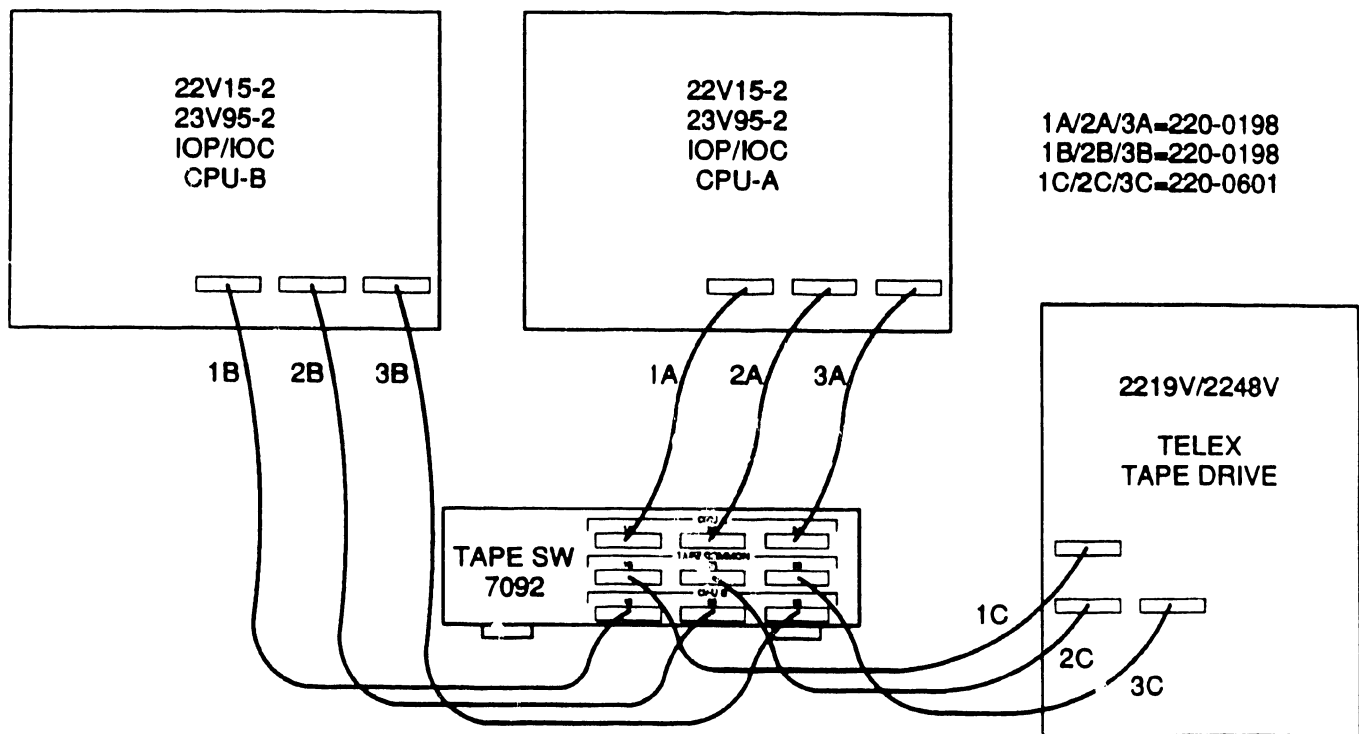

Figure 8. Typical Model 2219V/2248V Tape Drive Configuration

5.0 INSTALLATION (Cont.)

5.2 Installation Procedures for Model 7092-KIT-1:

The Model 7092-KIT-1 installation kit contains the following cables:

Six cables (WLI 220-0198)

Three cables (WLI 220-0601)

Use the following procedure to install the Model 2219V/2248V tape drive switch:

1. Turn off the tape drive power.
2. Turn off power to VS CPU A and VS CPU B systems.
3. Disconnect three cables that are attached to existing VS system and 2219V/2248V Telex drive. Connect three cables (WLI 220-0601) to three I/O connectors on the 2219V Telex drive. (Figure 8)
4. Plug free ends of three cables in Step 3 into corresponding connectors 1C, 2C, and 3C on the rear panel of the Model 7092 Tape Drive Switch unit. (Figure 8)
5. Connect three cables (WLI 220-0198) from VS CPU A I/O tape panel to corresponding connectors 1A, 2A, and 3A on the rear panel of the Model 7092 Tape Drive Switch unit. (Figure 8)
6. Connect three cables (WLI 220-0198) from VS CPU B I/O tape panel to corresponding connectors 1B, 2B, and 3B on the rear panel of the Model 7092 Tape Drive Switch unit. (Figure 8)
7. Connect AC power cord. (Figure 3)

NOTE

Ensure all cables are plugged into correct connectors and securely fastened with screws provided in the cable connectors.

5.0 INSTALLATION (Cont.)

5.3 VS 300/7000 Telex Tape Drive Connectors

The Telex tape connector assembly (WLI 270-1007) is used when one or more Telex tape drives are connected to the VS 300/7000 mainframe. Three 50-pin sockets (labeled 0, 1, and 2) are located on the assembly for connection to the drives.

NOTE

Check orientation of cable plugs when inserting them into 50-pin sockets.

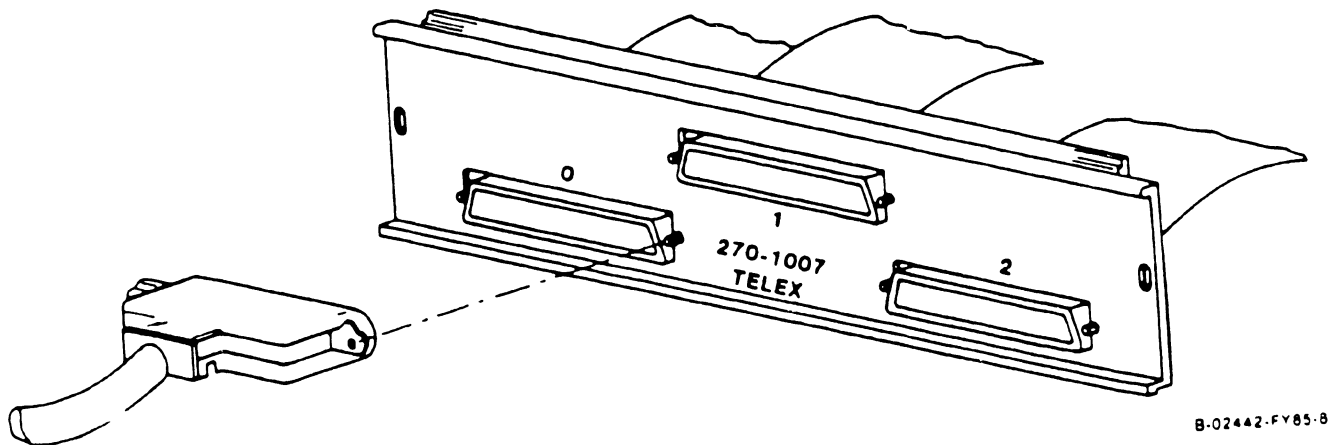

Figure 9. 270-1007 Telex Tape Drive Connector Assembly

6.0 FIELD REPLACEABLE UNITS (FRUs) LISTED BY WANG PART NUMBER

Model 7092 Telex VS AB Tape Switch

Model No. 7092
CEI No. 157/177-7551

Table 1.1 7092 VS AB Tape Switch FRUs

<u>WLI Number</u>	<u>Description</u>
210-9181	AB Tape Switch PCA
725-2820	Power Supply
220-0356	Cable, BNC-BNC, 25 ft.
220-0198	Cable, VS to SW, 14.0 ft.
220-0601	Cable, SW to Frmttr, 5.0 ft.
420-2040	AC Power Cord, NEMA 5-15P, 8 ft.

7.0 SPECIFICATIONS

Temperature Range

Storage (packaged)	0 to 120 degrees F (-17 to 50 degrees C)
Non-operating	0 to 120 degrees F (-17 to 50 degrees C)
Operating	60 to 90 degrees F (16 to 32 degrees C)

Operating temp. change/hr. 12 degrees F (6.5 degrees C)

Voltage Range

AC Input Voltage 115 or 220 VAC 50/60 Hz. (Switch Selectable).

Humidity Range

Storage (packaged)	10% to 90%
Non-operating (unpackaged)	10% to 90%
Operating (non-condensing)	20% to 80%

Physical Specifications

14" D x 19" W x 6" H
Weight 3 lbs.

Service Space Requirements

Front	12 inches.
Rear	12 inches
Left	2 inches
Right	2 inches
Top	6 inches

Input Current

115 VAC @ 1.0 Amps.
220 VAC @ 0.5 Amps.

Input Power

Each AB Tape Switch installed will result in an 11 Watt load on the external power source.

Heat Loss

37 BTU/hr. (9.3 KgCal/hr.)

Power Cord Data

Plug Type	NEMA 5-15P
Length	8 ft.

SECTION

7

**LOGIC AND
SCHEMATIC
DRAWINGS**

SECTION 7

7.1 INDEX of LOGIC and SCHEMATIC DRAWINGS

Drawing No.	Sheets	Title	PCB Location
92D20582		Power Supply	
92D20651		System Schematic	
92D20603		Pneumatic System	
92D71800		AC Power Control	
92C71801		Vacuum Chamber LED	
92C71803		Sensor, BOT-EOT	
92D71805	3	Reel Preamp	J4
92C71806		Sensor, Reel Tachometer	
92D71807		Reel Power Amp	J1 (Fixed), J2 (File)
92C71808		Sensor, Tape Pack	
92C71809		Sensor, Vacuum Chamber	
92C71810		Cartridge Opener	
92C71812		Solenoid Driver	
92C71813		Dump Circuit	
92D71814		Capstan Power Amp	J3
92D71822	2	Capstan Preamp	J6
92D71827		Switch Board	
92D71830	3	AGC & AMP Sense	J9
92D71835	5	Control Logic	J5
92D71837		Differential Switch	
92C71839		Sensor, Write Enable	
92D72201	10	PE/GCR Read Electronics	J11
92D72202	8	NRZI Read Electronics	J10
92D72203	6	Telex Interface	J7
92D72204		Operator Control Panel	
92D72205	5	Write Electronics	J8
92D72206		Card Index	

- NOTES
- FOR ASSEMBLY DRAWING SEE 91022279.
 - PARTIAL REFERENCE DESIGNATIONS ARE SHOWN. FOR COMPLETE REF. DES., PREFIX WITH UNIT NO. OR SUBASSEMBLY DES. EXAMPLE: A1 IS A2A1.
 - ▽ DENOTES LOGIC GRD.
 - ▽ DENOTES SERVO GRD.
 - W DENOTES BUS BAR.
 - E DENOTES TERMINAL TO CHASSIS GRD.
 - H INDICATES HEAT SINK.
 - SEE CABLE ASS'Y 91C22379.
 - INSULATE & TY-BACK WIRE NO. 50 & 57 WHEN NOT IN USE.

DO NOT SCALE THIS PRINT

REVISIONS			
LT#	DESCRIPTION	DATE	APP
1	REV. REF. CON. # 2/1979	12/17/79	PEJ
2	REV. REF. CON. # 1-0190-2	1-8-80	PEJ

TRANSFORMER TERMINATION										
TERM	1	2	3	4	5	6	7	8	9	10
VOLTS	100	115	200	220	230	240	250	200	220	230
JUMPERS										

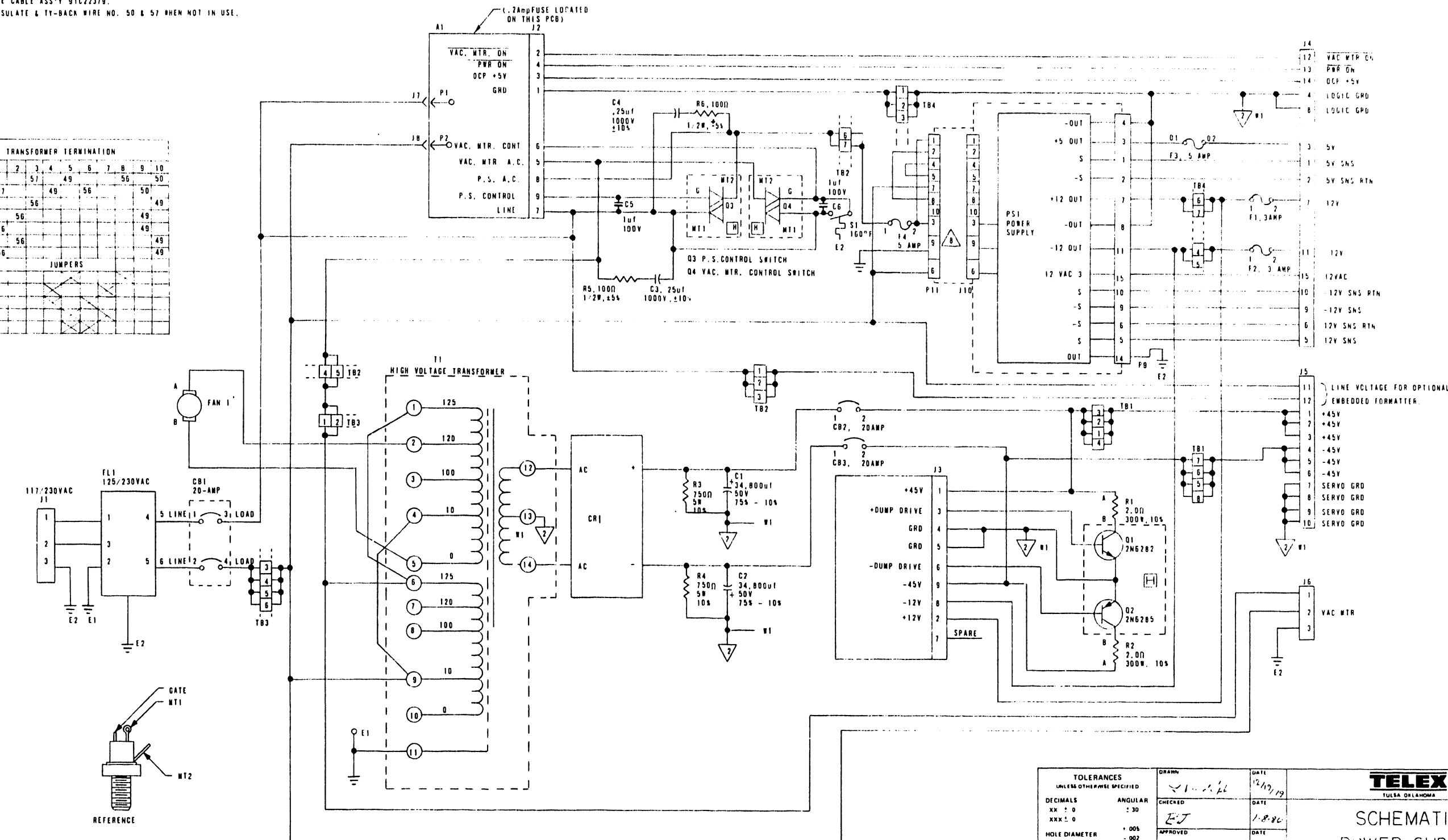

TOLERANCES UNLESS OTHERWISE SPECIFIED		DRAWN	DATE
DECIMALS	ANGULAR	✓ 1-2-79	12/17/79
XX ± 0	± 30	CHECKED	DATE
XXX ± 0		PEJ	1-8-80
HOLE DIAMETER	± 0.05	APPROVED	DATE
THREAD CLASS	NO 2		

TELEX
TULSA OKLAHOMA

**SCHEMATIC-
POWER SUPPLY**

PART NUMBER	91E22279	6250/40	FINISH	
NEXT ASSEMBLY		USED ON		
APPLICATION				

CODE IDENT NO		SIZE	D
SCALE	1:1	SHEET	1 OF 1

92D20582

NOTES

DO NOT SCALE THIS PRINT

REV	DESCRIPTION	DATE	APP
A	REVISED TO 490-A	11/70	LK/TJ

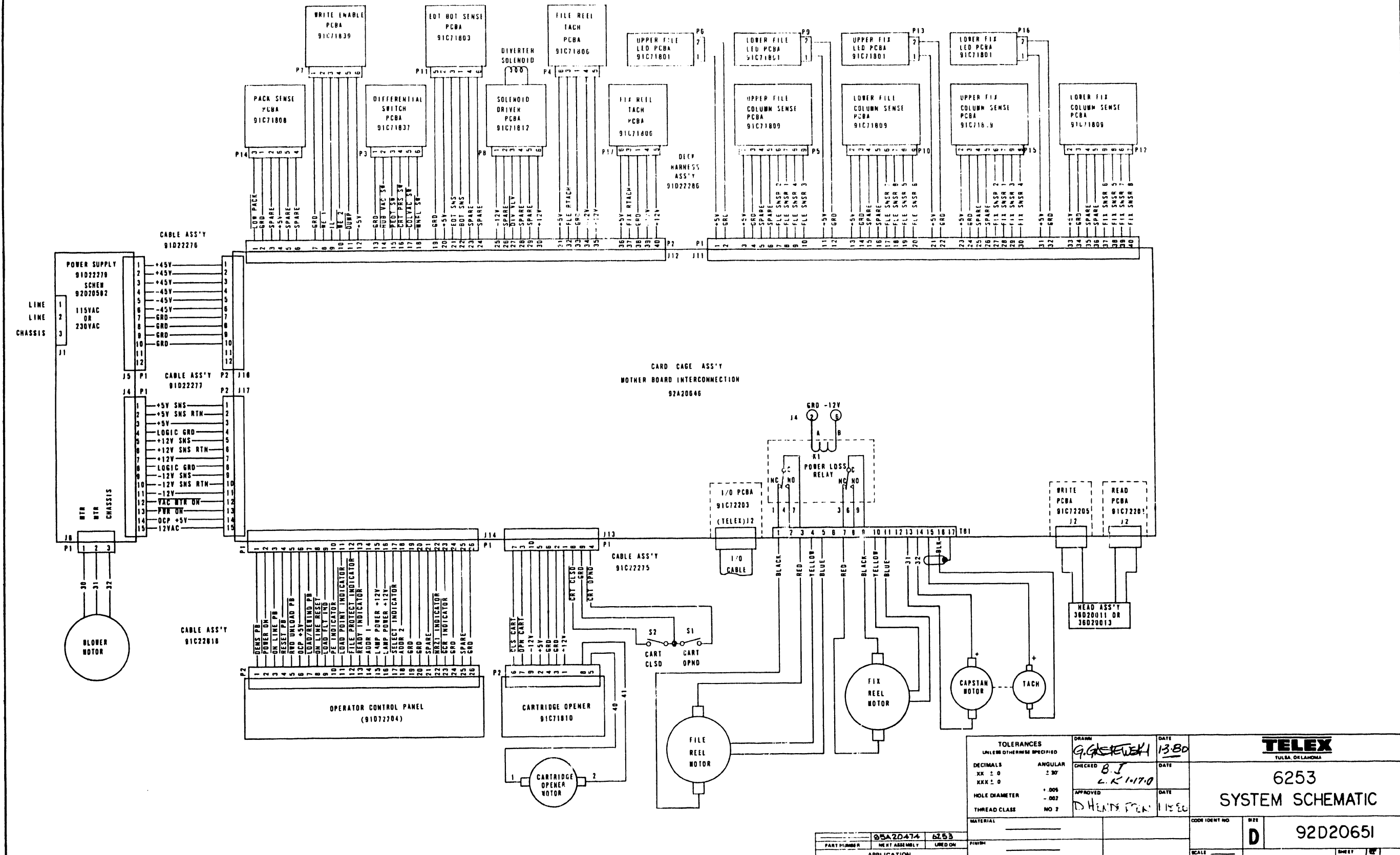

TOLERANCES UNLESS OTHERWISE SPECIFIED		DRAWN	DATE	TELEX TULSA, OKLAHOMA		
DECIMALS	ANGULAR	9. G. STEVENSON	13.80			
XX ± 0	± 30'	CHECKED	DATE	6253 SYSTEM SCHEMATIC		
XXX ± 0		B. J.				
HOLE DIAMETER	+ .005	L. K. 11/70				
THREAD CLASS	- .002	APPROVED	DATE	D. HEATLY FOR		
MATERIAL	NO 2		11/80			
PART NUMBER	92A20474	6253		CODE IDENT NO	D	92D20651
NEXT ASSEMBLY	USED ON	FINISH		SCALE		SHEET 1/1
APPLICATION						

NOTES

DO NOT SCALE THIS PRINT

REV	DESCRIPTION	DATE	BY
A	REV PER DCN # 457-23	10-17-77	...
B	REV PER DCN # 1-3602-2	2-6-78	...
C	REV PER DCN # 1-3395	1-16-78	...
D	REV PER DCN # 1-3414	1-27-79	...
E	REV PER DCN # 1-3602-2	1-27-79	...
F	REV PER DCN # 1-5410-3	10-21-80	...
G	REV PER DCN # 1-5441	10-21-80	...

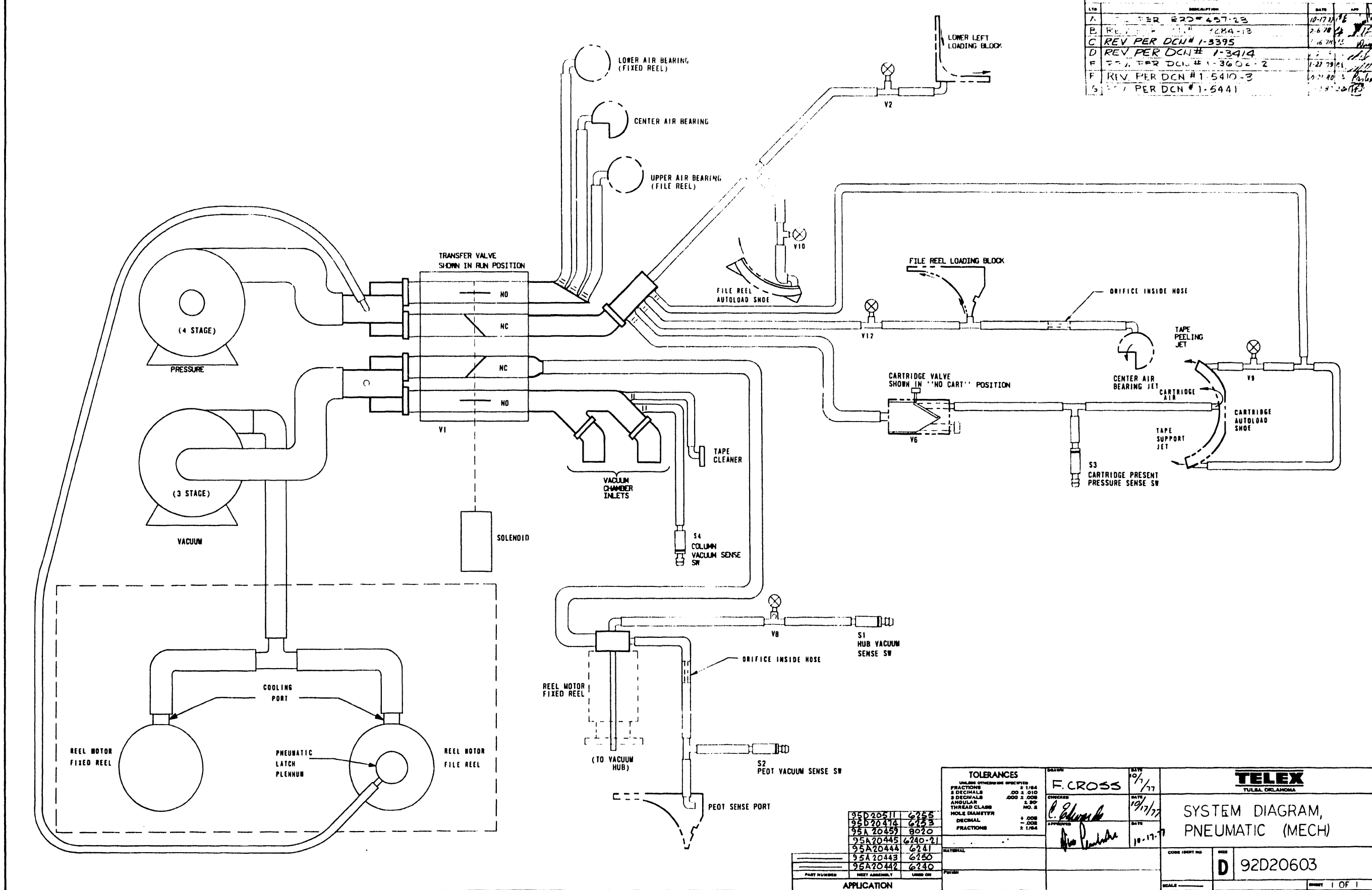

95D20511	6255
95D20474	6253
95A20457	8020
95A20445	6240-21
95A20444	6241
95A20443	6250
95A20442	6240

TOLERANCES	
UNLESS OTHERWISE SPECIFIED	± 1/64
FRACTIONS	± .010
DECIMALS	± .005
ANGULAR	± .30°
THREAD CLASS	NO. 2
HOLE DIAMETER	± .005
DECIMAL	± .005
FRACTIONS	± 1/64

DATE	10/17/77
BY	F. CROSS
DATE	10/17/77
BY	...
DATE	10-17-77
BY	...

TELEX	
TULSA, OKLAHOMA	
SYSTEM DIAGRAM, PNEUMATIC (MECH)	
CORE (PRINT NO.)	D 92D20603
SCALE	INCH 1 OF 1

NOTES:

- UNLESS OTHERWISE SPECIFIED:
1. RESISTANCE VALUES ARE IN OHMS, 1/4 W
 2. CAPACITANCE VALUES ARE MICROFARADS.
 3. A-01 PRIMARY 117 VOLT
A-02 PRIMARY 220 VOLT

DO NOT SCALE THIS PRINT

REVISIONS			
LTR	DESCRIPTION	DATE	APP
A	REVISED TO #488-10	10-28-80	LR
B	REV. PER DCN #1-5468	1-5-91	TR

1-5550

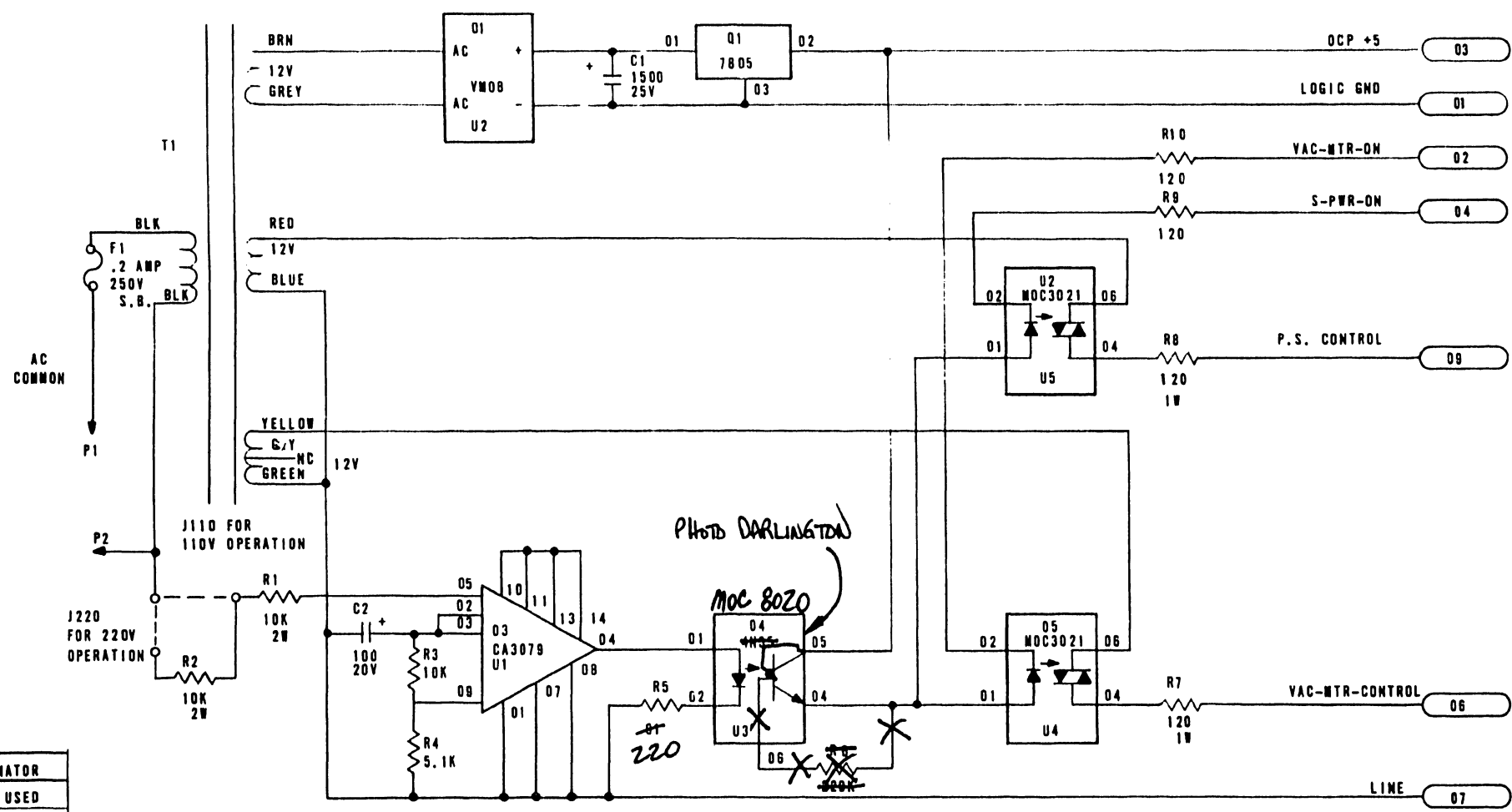

REFERENCE DESIGNATOR	
LAST USED	NOT USED
C2	
R10	
Q1	
T1	
U5	

B	92C72261-02	6200/8020
B	92C72261-01	6200
	PART NUMBER	USED ON
	NEXT ASSEMBLY	
	APPLICATION	

<p>TOLERANCES UNLESS OTHERWISE SPECIFIED</p> <p>DECIMALS .XX ± .0 XXX ± .0</p> <p>HOLE DIAMETER +.005 -.002</p> <p>THREAD CLASS NO. 2</p>	<p>DRAWN K. ABERNATHY</p> <p>CHECKED C. Edwards</p> <p>APPROVED K. Abernathy</p>	<p>DATE 10/8/80</p> <p>DATE 10/17/80</p> <p>DATE 11/13/80</p>	<p>TELEX TULSA, OKLAHOMA</p> <p>SCHMATIC AC POWER CONTROL</p>	
	<p>MATERIAL</p>			<p>CODE IDENT NO.</p>
	<p>FINISH</p>			<p>SIZE C</p>
	<p>APPLICATION</p>			<p>SCALE NOTE</p>

SHEET 1 OF 1

NOTES

1. RESISTANCE VALUES ARE IN OHMS 1/4W, 5%.
2. DIODES ARE SE5455-4.

DO NOT SCALE THIS PRINT

REVISIONS			
LTR	DESCRIPTION	DATE	APP.
	PROTO RELEASE		
A	EO 0036		
B	EO 0090		
C	EO 0181		
D	EO 0195		
E	RELEASE PER ERO 457-7	5-3-77	JLD
F	REV. PER DCN # 1-3418	5-30-78	CS JLD
G	REV. PER DCN # 1-3678-2	4-5-79	LK DH
H	REV. PER DCN # 1-4084	1-7-80	BJ WTY

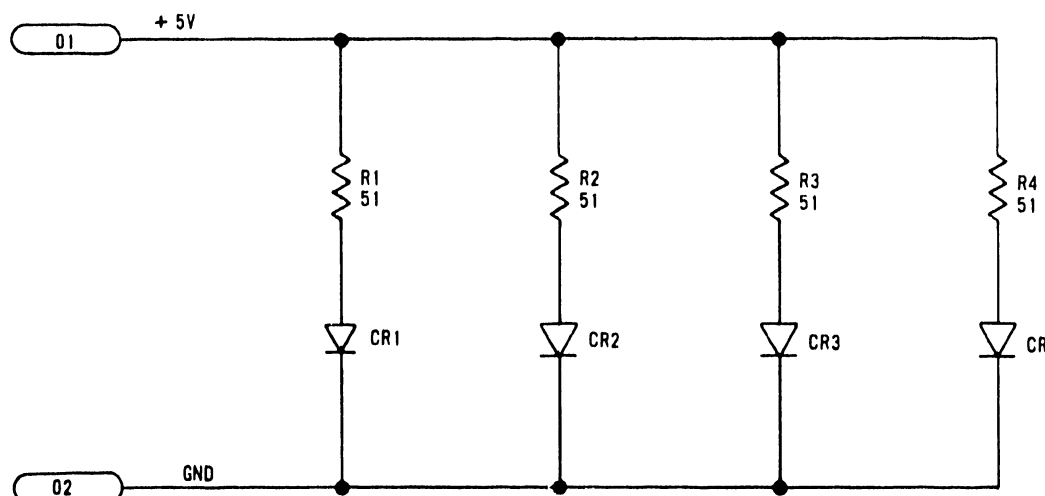

CR4	
R4	
LAST USED	NOT USED

TOLERANCES <small>UNLESS OTHERWISE SPECIFIED</small> FRACTIONS ± 1/64 2 DECIMALS .00 ± .010 3 DECIMALS .000 ± .008 ANGULAR ± 30' THREAD CLASS NO. 2 HOLE DIAMETER DECIMAL + .008 - .002 FRACTIONS ± 1/64		DRAWN J. E. HEWITT CHECKED <i>[Signature]</i> APPROVED <i>[Signature]</i>	DATE 4/20/1977 DATE 4/28/77 DATE 5-2-77	TULSA, OKLAHOMA TELEX SCHEMATIC - VACUUM CHAMBER L E D A8
MATERIAL FINISH		CODE IDENT NO. C	SIZE 92C71801	SCALE NONE SHEET 1 OF 1

C91C71801-01		6250/40
C91C71801-02		6250/30
PART NUMBER	NEXT ASSEMBLY	USED ON
APPLICATION		

NOTES:

DO NOT SCALE THIS PRINT

REVISIONS			
LTR	DESCRIPTION	DATE	APP.
-	PROTO RELEASE		
A	EO D190 Δ_1 - Δ_2		
B	RELEASE PER ERO 457-7	4/23/77	<i>[Signature]</i>
C	REV PER DCN # 1-3395	5-16-78	<i>[Signature]</i>
D	REV PER DCN # 1-3418	5-30-78	<i>[Signature]</i>
E	REV PER DCN # 1-4084	1-7-80	<i>[Signature]</i>

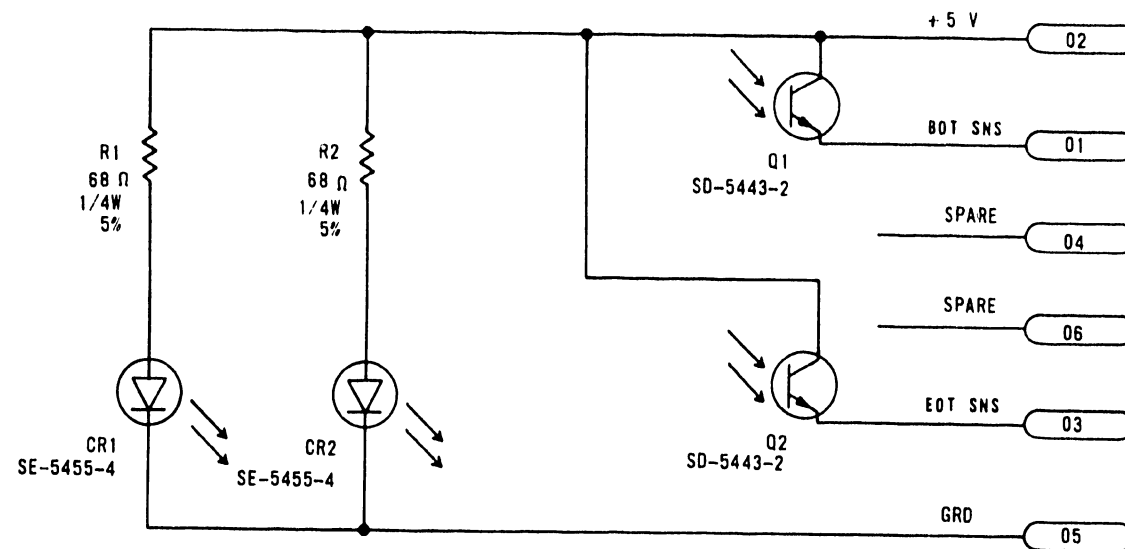

Q2	
CR2	
R2	
LAST USED	NOT USED

A91C71803-01	6250/40
PART NUMBER	USED ON
APPLICATION	

TOLERANCES UNLESS OTHERWISE SPECIFIED FRACTIONS $\pm 1/64$ 2 DECIMALS $\pm .010$ 3 DECIMALS $\pm .008$ ANGULAR $\pm 30'$ THREAD CLASS NO. 2 HOLE DIAMETER DECIMAL $+.008$ DECIMAL $-.002$ FRACTIONS $\pm 1/64$	DRAWN J.E. HEWITT DATE 4/14/77	TELEX TULSA, OKLAHOMA SCHEMATIC - EOT / BOT CODE IDENT NO. C 92C71803 SCALE NONE	
	CHECKED <i>[Signature]</i> DATE 4-28-77		DATE 4/30/77
	APPROVED <i>[Signature]</i>		

NOTES:
 1 INTERNAL CKT GRD UNLESS OTHERWISE SPECIFIED. RESISTORS ARE 1% 4W, 5% DIODES ARE 1N914 14 PIN IC'S - CONNECT PIN 14 TO GND
 2 SINGLE ALPHA CHARACTERS DENOTES SHEET TO SHEET CONNECTION. DOUBLE ALPHA CHARACTERS DENOTES INTERNAL CONNECTION G-SMT 2

REV	DESCRIPTION	DATE	APP
1	REVISED DRAWING # 1-5256-2	10-31-77	J4
2	REVISED DRAWING # 1-5237-2	10-31-77	J4
3	REVISED DRAWING # 1-5309	10-31-77	J4
4	REVISED DRAWING # 1-5314	10-31-77	J4
M	REVISED DRAWING # 1-5325-5	10-31-77	J4

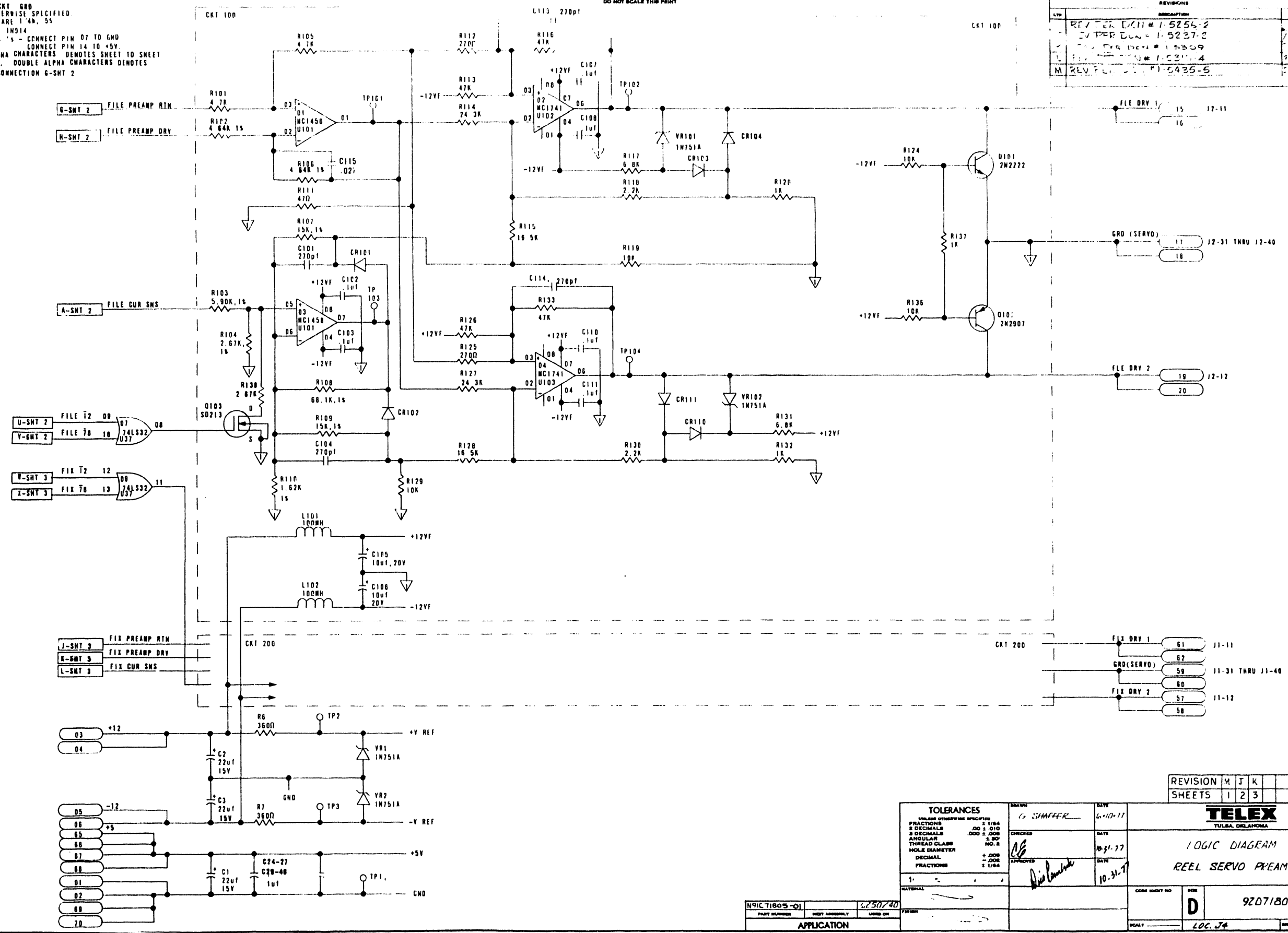

REVISION	M	J	K		J4
SHEETS	1	2	3		

TOLERANCES
 UNLESS OTHERWISE SPECIFIED:
 FRACTIONS ± 1/64
 5 DECIMALS .00 ± 0.10
 3 DECIMALS .000 ± .008
 ANGULAR ± 30'
 THREAD CLASS NO. 2
 HOLE DIAMETER + .008
 DECIMAL - .008
 FRACTIONS ± 1/64

DATE: 10-31-77
 DRAWN: G. SHAFER
 CHECKED: [Signature]
 APPROVED: [Signature]

TELEX
 TULSA, OKLAHOMA

LOGIC DIAGRAM
 REEL SERVO PREAMP

92071805-01	REVISED DRAWING # 1-5256-2	DATE: 10-31-77	SCALE: LOG J4
APPLICATION	92071805	DATE: 10-31-77	SCALE: 1 OF 5

NOTES

DO NOT SCALE THIS PRINT

REVISIONS			
REV	DESCRIPTION	DATE	APP
H	REV PER DCN # 1-5237-2	7-5-77	
J	REV PER DCN # 1-5315-4	1-10-78	

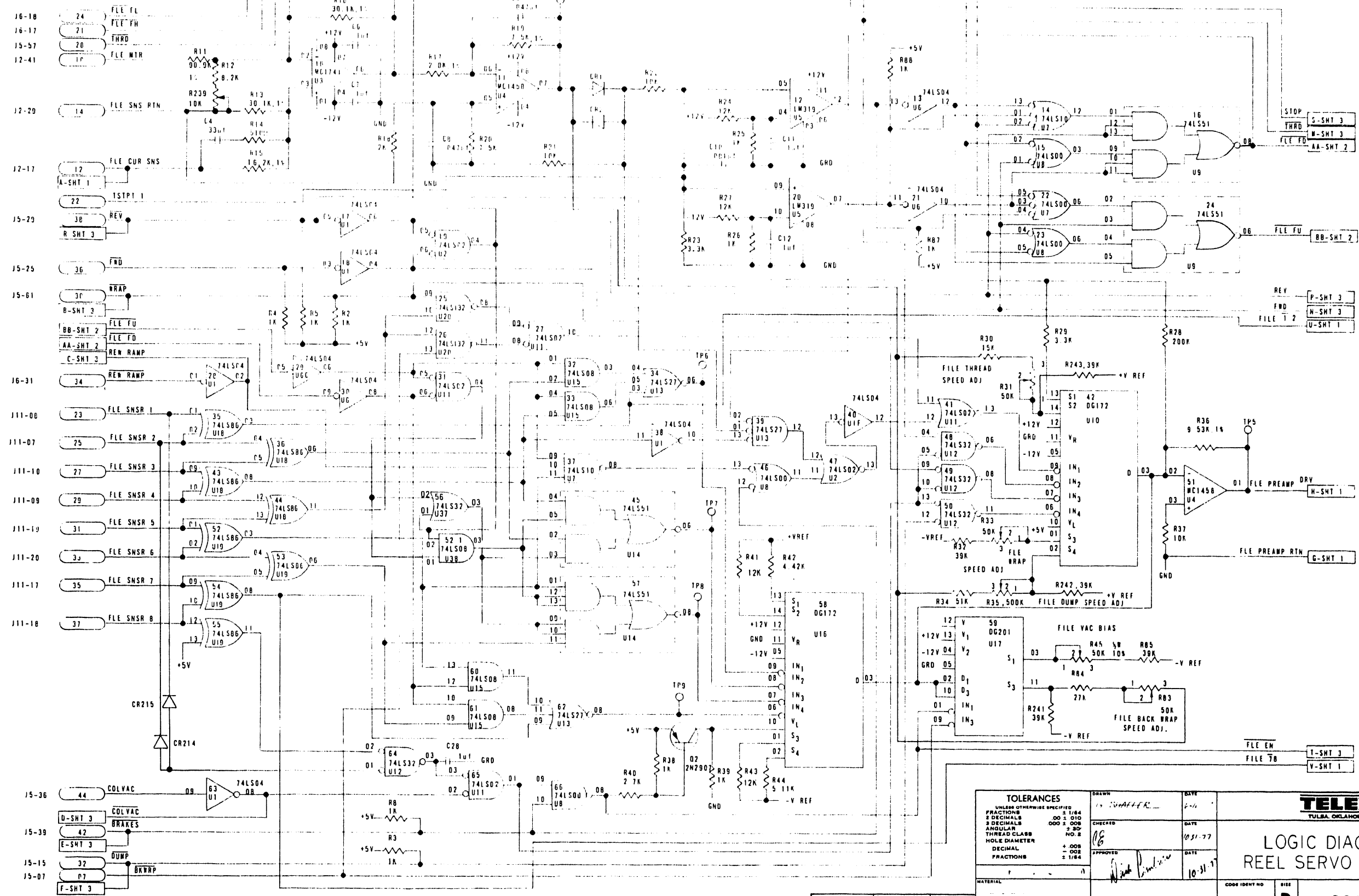

- 16-18 24 FLE FL
- 16-17 21 FLE FH
- 15-57 20 THRD
- 12-41 1P FLE MTR
- 12-20 14 FLE SNS RTN
- 12-17 12 FLE CUR SNS
- 15-20 22 1STPT 1
- 38 REV
- 15-25 36 FRD
- 15-61 30 WRAP
- B-SHT 3
- BB-SHT 2 FLE FU
- AA-SHT 2 FLE FD
- C-SHT 3 REN RAMP
- 16-31 34 REN RAMP
- 111-06 23 FLE SNR 1
- 111-07 25 FLE SNR 2
- 111-10 27 FLE SNR 3
- 111-09 29 FLE SNR 4
- 111-19 31 FLE SNR 5
- 111-20 32 FLE SNR 6
- 111-17 35 FLE SNR 7
- 111-18 37 FLE SNR 8
- 15-36 44 COL VAC
- 15-39 42 COL VAC
- E-SHT 3 BRAKES
- 15-15 32 DUMP
- 15-07 17 BKWRP

TOLERANCES		DATE
UNLESS OTHERWISE SPECIFIED		10-31-77
FRACTIONS	± 1/64	
DECIMALS	± 0.010	
3 DECIMALS	± 0.005	
ANGULAR	± 30'	
THREAD CLASS	NO. 2	
HOLE DIAMETER	+0.000	
DECIMAL	-0.002	
FRACTIONS	± 1/64	

TELEX		DATE
TULSA, OKLAHOMA		10-31-77
LOGIC DIAGRAM		
REEL SERVO PREAMP		

PART NUMBER	SEE SHT. 1 250/40	FINISH	
APPLICATION		SCALE	LOC J4
CODE IDENT NO	D	SHEET	2 OF 3
	92D71805		

NOTES:

DO NOT SCALE THIS PRINT

REV	DESCRIPTION	DATE	APP
B	REV PER DCN # 1-3205	10-11-77	...
C	REV PER DCN # 1-3395
F	REV PER DCN # 1-3430-2
F	REV PER DCN # 1-3673-3
G	REV PER DCN # 1-5230-2
H	REV PER DCN # 1-5256-2
J	REV PER DCN # 1-5227-2
K	REV PER DCN # 1-5435-5

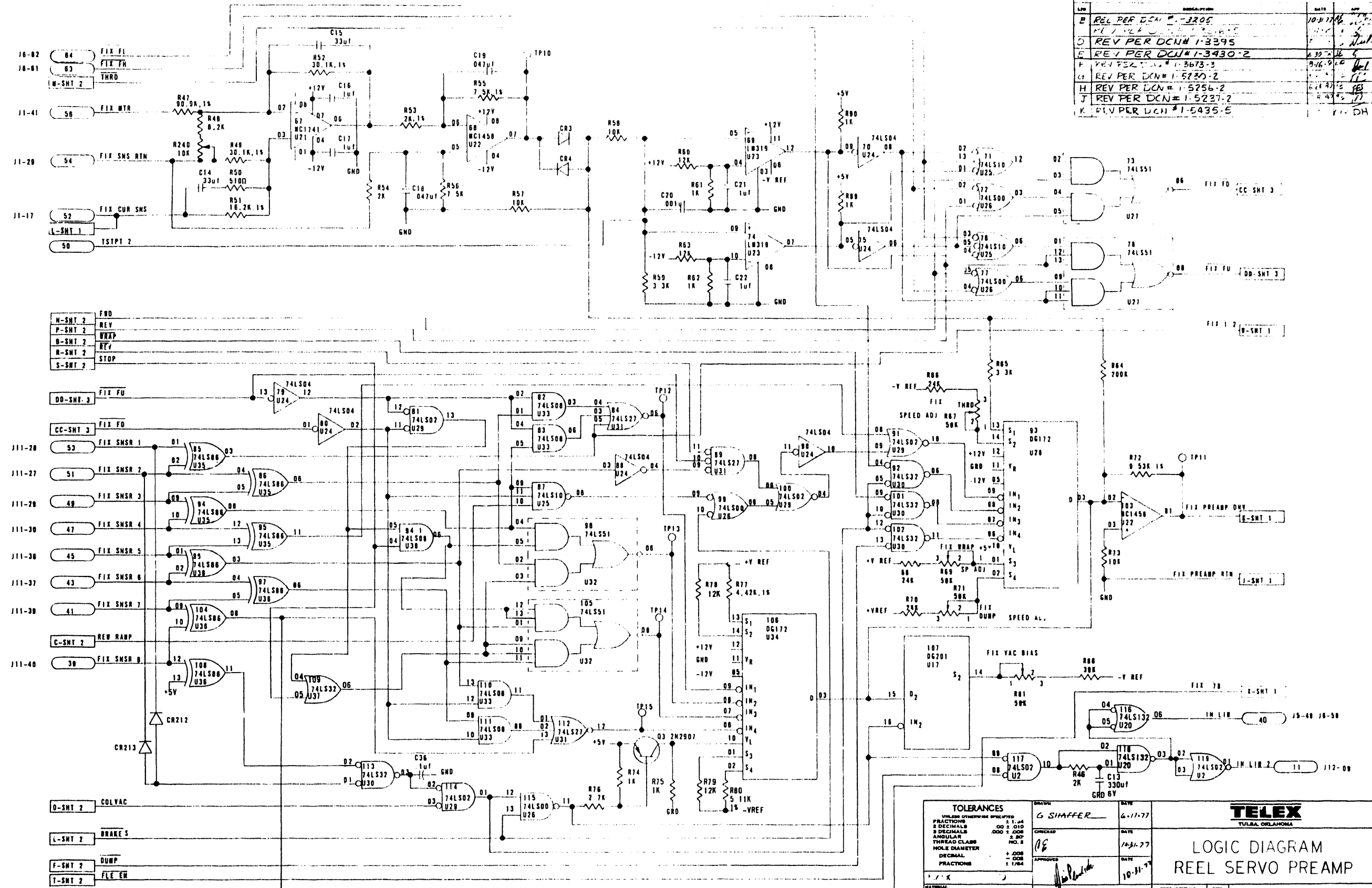

- FBD
- M-SMT 2 REV
- P-SMT 2 WRAP
- B-SMT 2 REV
- R-SMT 2 STOP
- S-SMT 2

- DD-SMT 3 FIX FU
- CC-SMT 3 FIX FD
- 111-20 53 FIX SNR 1
- 111-27 51 FIX SNR 2
- 111-20 49 FIX SNR 3
- 111-30 47 FIX SNR 4
- 111-38 45 FIX SNR 5
- 111-37 43 FIX SNR 6
- 111-38 41 FIX SNR 7
- C-SMT 2 REW RAMP
- 111-40 38 FIX SNR 8

- D-SMT 2 COL VAC
- L-SMT 2 BRAKE S
- F-SMT 2 DUMP
- T-SMT 2 FLE EN

TOLERANCES	
UNLESS OTHERWISE SPECIFIED	1/16"
FRACTIONS	002, 010
DECIMALS	002, 008
ANGULAR	30"
THREAD CLASS	NO. 2
HOLE DIAMETER	0.008
DECIMAL	0.008
FRACTIONS	1/64"

DRAWN	G SIMAFFER	DATE	6-11-77
CHECKED	...	DATE	10-31-77
APPROVED	...	DATE	10-31-77

TELEX
TULSA, OKLAHOMA

LOGIC DIAGRAM
REEL SERVO PREAMP

PART NUMBER	92D7180.5	REVISED	6250140
APPLICATION	...		
SCALE	LOC 74	SHEET	3 OF 3

- NOTES
- 1 RESISTANCE VALUES ARE IN OHMS 5% 1/4W
 - 2 CAPACITANCE VALUES ARE IN MICRO-FARADS, 20%, 50V

DO NOT SCALE THIS PRINT

REVISIONS			
LTR	DESCRIPTION	DATE	APP.
C	REV PER DCN # 1-4084	1/7/80	BJ
H	REV PER DCN # 1-5186-2	8/16/81	Bl

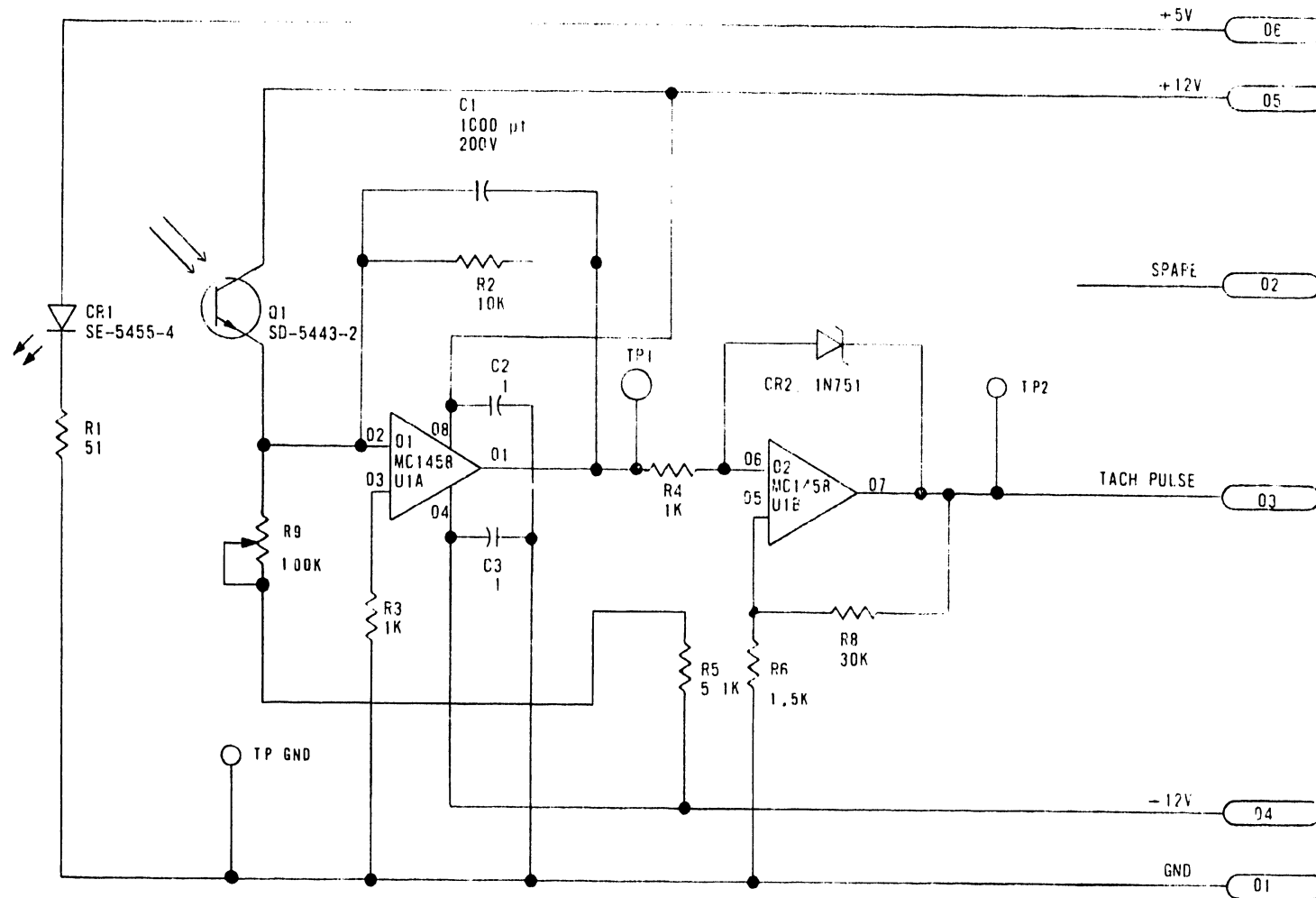

REFERENCE DESIGNATIONS	
LAST USED	NOT USED
R8	
CR2	
C3	
U1	
Q1	

TOLERANCES		DRAWN	DATE
UNLESS OTHERWISE SPECIFIED		<i>[Signature]</i>	1/6/76
FRACTIONS	± 1/64	CHECKED	DATE
2 DECIMALS	± 0.010	<i>[Signature]</i>	4/29/77
3 DECIMALS	± 0.005	APPROVED	DATE
ANGULAR	± 30'	<i>[Signature]</i>	4/6/77
THREAD CLASS	NO. 2		
HOLE DIAMETER	+ .005		
DECIMAL	- .002		
FRACTIONS	± 1/64		
MATERIAL			
FINISH			

TELEX	
TULSA, OKLAHOMA	
SCHEMATIC - SENSOR, REEL TACH	
CODE IDENT NO	SIZE
	C
92C71806	
SCALE NONE	SHEET 1 OF 1

PART NUMBER	NEXT ASSEMBLY	USED ON
92C71806-01		6250/40
APPLICATION		

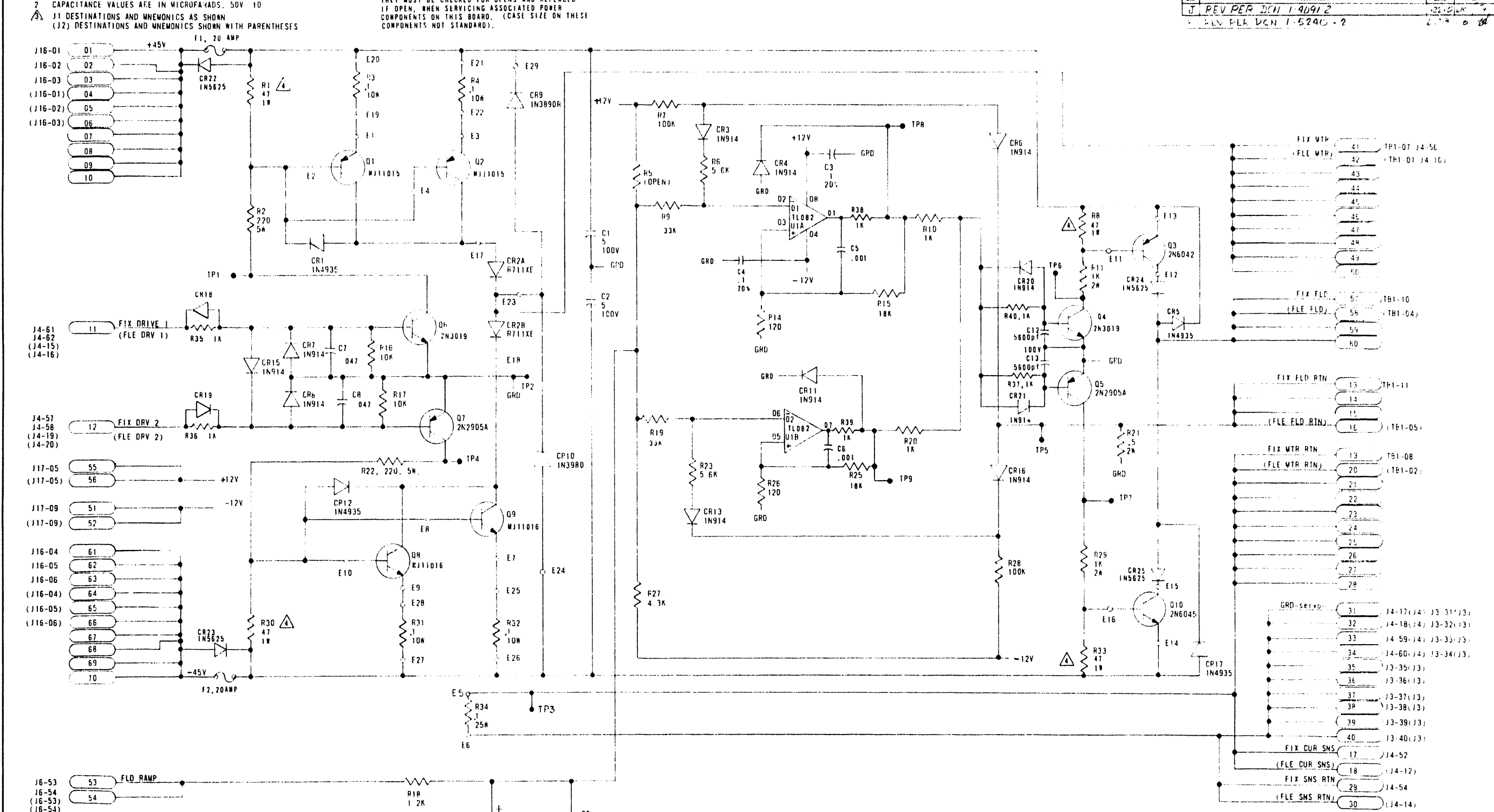

LAST USED	NOT USED
P40	R13, 24
U1	
Q10	
C13	
CR25	CR14

TOLERANCES		DATE
UNLESS OTHERWISE SPECIFIED	± 1/84	5-17
FRACTIONS	± 0.010	
DECIMALS	± 0.005	
ANGULAR	± 30'	
THREAD CLASS	NO 2	
HOLE DIAMETER	+ 0.005	
DECIMAL	- 0.005	
FRACTIONS	± 1/84	

DRAWN: *F. CROSS*
 CHECKED: *J. [unclear]*
 APPROVED: *W. [unclear]*

TELEX
TULSA, OKLAHOMA

LOGIC DIAGRAM
REEL POWER AMP

DATE: 5-17
 DATE: 5-4-77
 DATE: 5/2/77

MATERIAL: [blank]
 FINISH: [blank]

CODE IDENT NO: [blank]
 SIZE: **D**
 92D71807

SCALE: 1/8" = 1" (LOC J14/J2)
 SHEET: 1 of 1

PART NUMBER	NEXT ASSEMBLY	USED ON	FINISH
K92D71807-01		6250/40	

APPLICATION

NOTES

1. UNLESS OTHERWISE SPECIFIED, RESISTANCE VALUES ARE IN OHMS 1/4W, 5%.

DO NOT SCALE THIS PRINT

REVISIONS			
LTR	DESCRIPTION	DATE	APP.
-	PROTO RELEASE		
A	EO 0009		
B	EO 0086		
C	RELEASE PER ERO 457-7	4/29/77	Schell
D	REV PER DCN # 1-3145	7-18-78	DM
E	REV PER DCN # 1-3395	5-16-78	DM
F	REV. PER DCN # 1-3418	5-30-78	DM
G	REV. PER DCN # 1-3841-2	8-23-94	DM

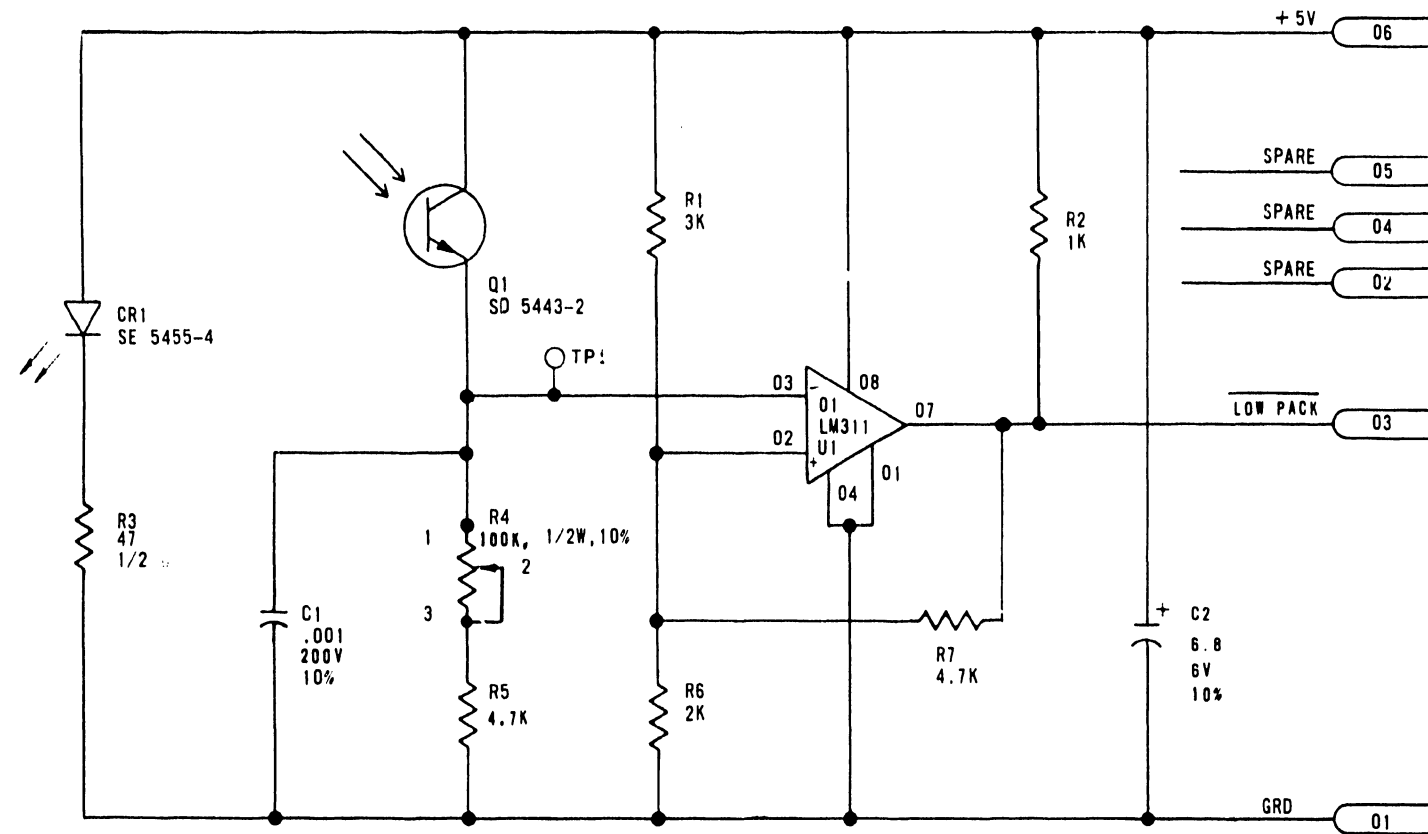

Q1	
U1	
C2	
CR1	
R7	
LAST USED	NOT USED

92C71808-01	6250/40
PART NUMBER	USED ON
APPLICATION	

TOLERANCES UNLESS OTHERWISE SPECIFIED FRACTIONS ± 1/64 2 DECIMALS 0 ± .010 3 DECIMALS .000 ± .005 ANGULAR ± 30' THREAD CLASS NO. 2 HOLE DIAMETER + .005 DECIMAL - .002 FRACTIONS ± 1/64	DRAWN J.E. HEWITT DATE 4/18/77	 TULSA, OKLAHOMA SCHEMATIC - PACK SENSE A3	
	CHECKED [Signature] DATE 4/28-77		APPROVED [Signature] DATE 4/30/77
	MATERIAL FINISH		
CODE IDENT NO.		SIZE C	
SCALE NONE		SHEET 1 OF 1	

NOTES

- 1 RESISTANCE VALUES ARE IN OHMS, 1/4W, 5%
- 2 TRANSISTORS ARE 2N5780

DO NOT SCALE THIS PRINT

REVISIONS			
LTR	DESCRIPTION	DATE	APP.
-	PROTO RELEASE		
A	EO 0011		
B	EO 0023		
C	EO 0194		
D	REL PER ERO #457-8	5/5/77	<i>[Signature]</i>
E	REV. PER DCN # 1-3418	5-30-78	<i>[Signature]</i>
F	REV PER DCN # 1-4084	1-7-80	<i>[Signature]</i>
G	REV PER DCN # 1-5071-2	2-25-0	<i>[Signature]</i>
H	REV. PER DCN # 1-5408	10-10-80	<i>[Signature]</i>

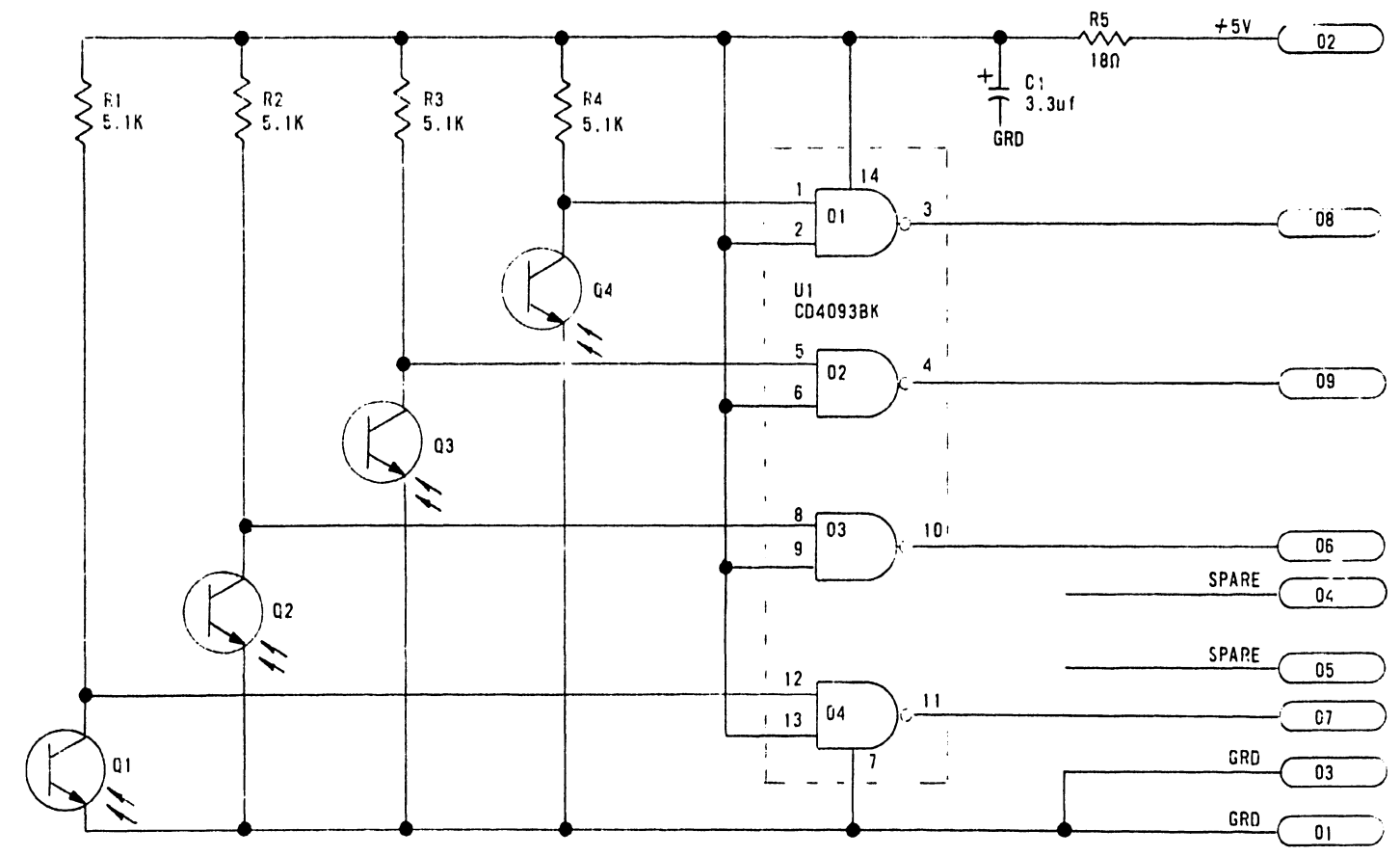

LAST USED	NOT USED
R 5	
U 1	
Q 4	
C 1	

PART NUMBER	NEXT ASSEMBLY	USED ON
C91C71809-01		6250/40
C91C71809-02		6250/40
C91C71809-01		6250/40
C91C71809-02		6250/40

TOLERANCES		DRAWN	DATE
UNLESS OTHERWISE SPECIFIED		F. CROSS	9 29 77
FRACTIONS	± 1/64	CHECKED	DATE
2 DECIMALS	.00 ± .010	<i>[Signature]</i>	5-2-77
3 DECIMALS	.000 ± .005	APPROVED	DATE
ANGULAR	± 30'	<i>[Signature]</i>	5/5/77
THREAD CLASS	NO. 2		
DECIMAL	+ .005		
FRACTIONS	- .002		
	± 1/64		

TELEX TULSA, OKLAHOMA	
SCHEMATIC, VACUUM CHAMBER SENSOR A1A16	
CODE IDENT NO.	SIZE
	C 92C71809
SCALE	SHEET 1 OF 1

NOTES

- RESISTANCE VALUES ARE IN OHMS 5%, 1/4 WATT, UNLESS OTHERWISE SPECIFIED.
- DIODES 1N4001, UNLESS OTHERWISE SPECIFIED.

DO NOT SCALE THIS PRINT

REVISIONS			
LTR	DESCRIPTION	DATE	APP.
-	PROTO RELEASE		
A	EQ 205 $\Delta 1$ - $\Delta 4$		
B	REL PER ERO #457-7	4-15-77	W.P.
C	REV PER DCN # 1-3395	5-17-78	W.P.
D	REV PER DCN # 1-3418	5-30-78	W.P.
E	REV PER DCN # 1-4084	1-7-80	B.I.
F	REV PER DCN 1-5216-3	6-5-80	C.E.

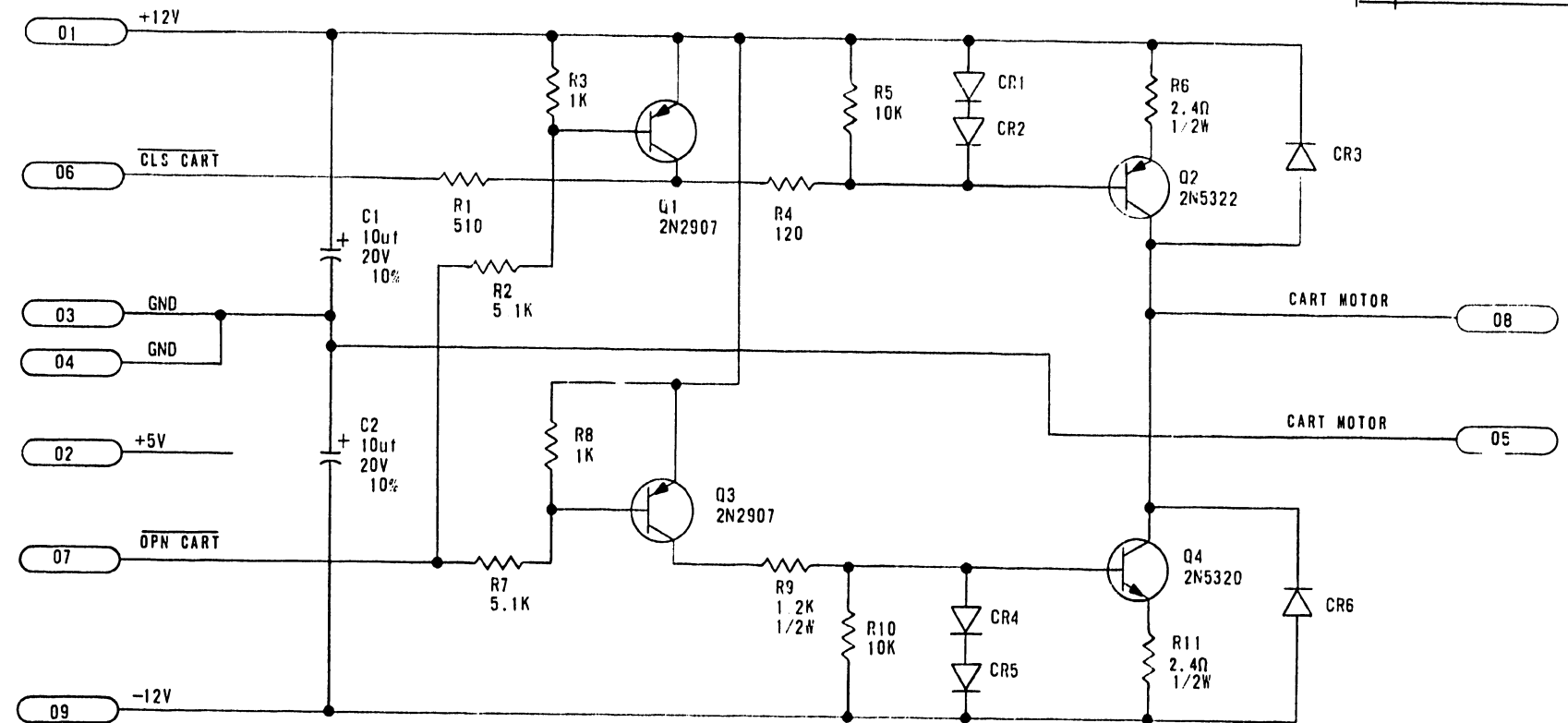

REFERENCE DESIGNATIONS	
LAST USED	NOT USED
C2	
R11	
Q4	
CR6	
S2	
B1	
P1	

TOLERANCES UNLESS OTHERWISE SPECIFIED FRACTIONS ± 1/64 2 DECIMALS .00 ± .010 3 DECIMALS .000 ± .005 ANGULAR ± 30' THREAD CLASS NO. 2 HOLE DIAMETER DECIMAL + .005 - .002 FRACTIONS ± 1/64	DRAWN <i>[Signature]</i> DATE 4/25/77	TELEX TULSA, OKLAHOMA SCHEMATIC, CARTRIDGE OPENER A3A1
	CHECKED <i>[Signature]</i> DATE 4-29-77	
	APPROVED <i>[Signature]</i> DATE 5-1-77	
MATERIAL MARK PER MIL - STD - 110	CODE IDENT NO. SIZE C	92C71810
APPLICATION 891C71810-01 SEE LM 8020 891C71810-01 SEE LM 6250/40	SCALE NONE	SHEET 1 OF 1

NOTES:

DO NOT SCALE THIS PRINT

REVISIONS			
LTR	DESCRIPTION	DATE	APP.
C	REV PER DCN # 1-3226-2	1-9-78	B. W.
D	REV PER DCN # 1-3395	1-10-78	B. W.
E	REV PER DCN # 1-3416	1-20-78	B. W.
F	REV PER DCN # 1-4094	1-20-78	B. W.
G	REV PER DCN # 1-5057	2-20-78	B. W.
H	REV PER DCN # 1-5267-3	10-3-78	B. W.

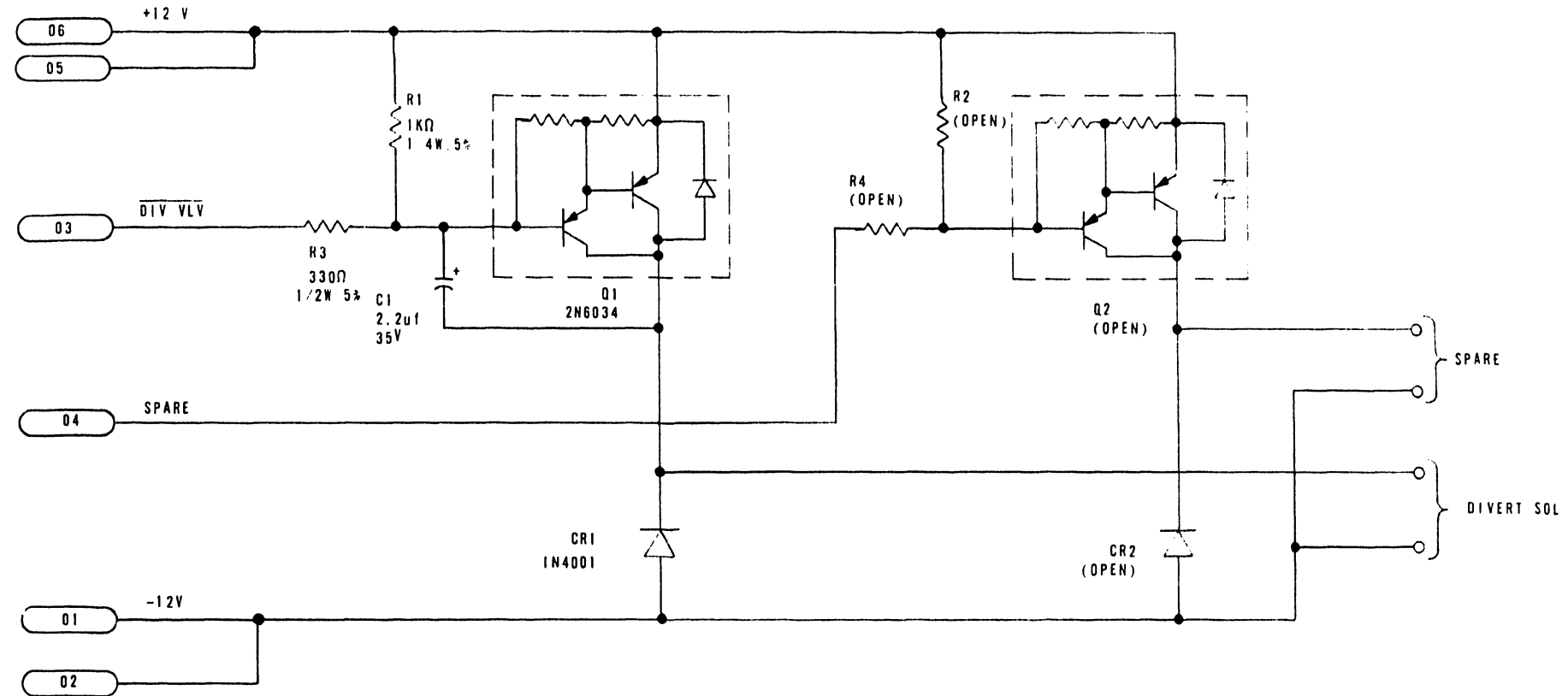

C1	
Q2	
CR2	
R4	
LAST USED	NOT USED

TOLERANCES UNLESS OTHERWISE SPECIFIED FRACTIONS ± 1/64 2 DECIMALS .00 ± .010 3 DECIMALS .000 ± .005 ANGULAR ± 30° THREAD CLASS NO. 2 HOLE DIAMETER DECIMAL + .005 - .002 FRACTIONS ± 1/64		DRAWN <i>A. W. ...</i> DATE 1-6-78	TELEX TULSA, OKLAHOMA
CHECKED <i>D. Edwards</i> DATE 1/9/78		APPROVED <i>D. H. ...</i> DATE 1-11-78	
MATERIAL FINISH		CODE IDENT NO. C	SIZE 92C71812
APPLICATION B91C71812-01 NEXT ASSEMBLY USED ON 6250/40		SCALE NONE	SHEET 1 OF 1

NOTES: 1. UNLESS OTHERWISE SPECIFIED
RESISTANCE VALUES ARE IN OHMS 1/4W, 5%
AND CAPACITANCE VALUES ARE IN MICROFARADS

DO NOT SCALE THIS PRINT

REVISIONS			
LTR	DESCRIPTION	DATE	APP.
	PROTO RELEASE		
A	EO 0192		
B	RELEASE PER ERO 457-7	4/22/77	[Signature]
C	REV. PER DCN # 1-3418	5-30-78	[Signature]
D	REV. PER DCN # 1-4084	1-7-80	[Signature]
E	REV. PER DCN # 1-5244-2	7-3-80	[Signature]

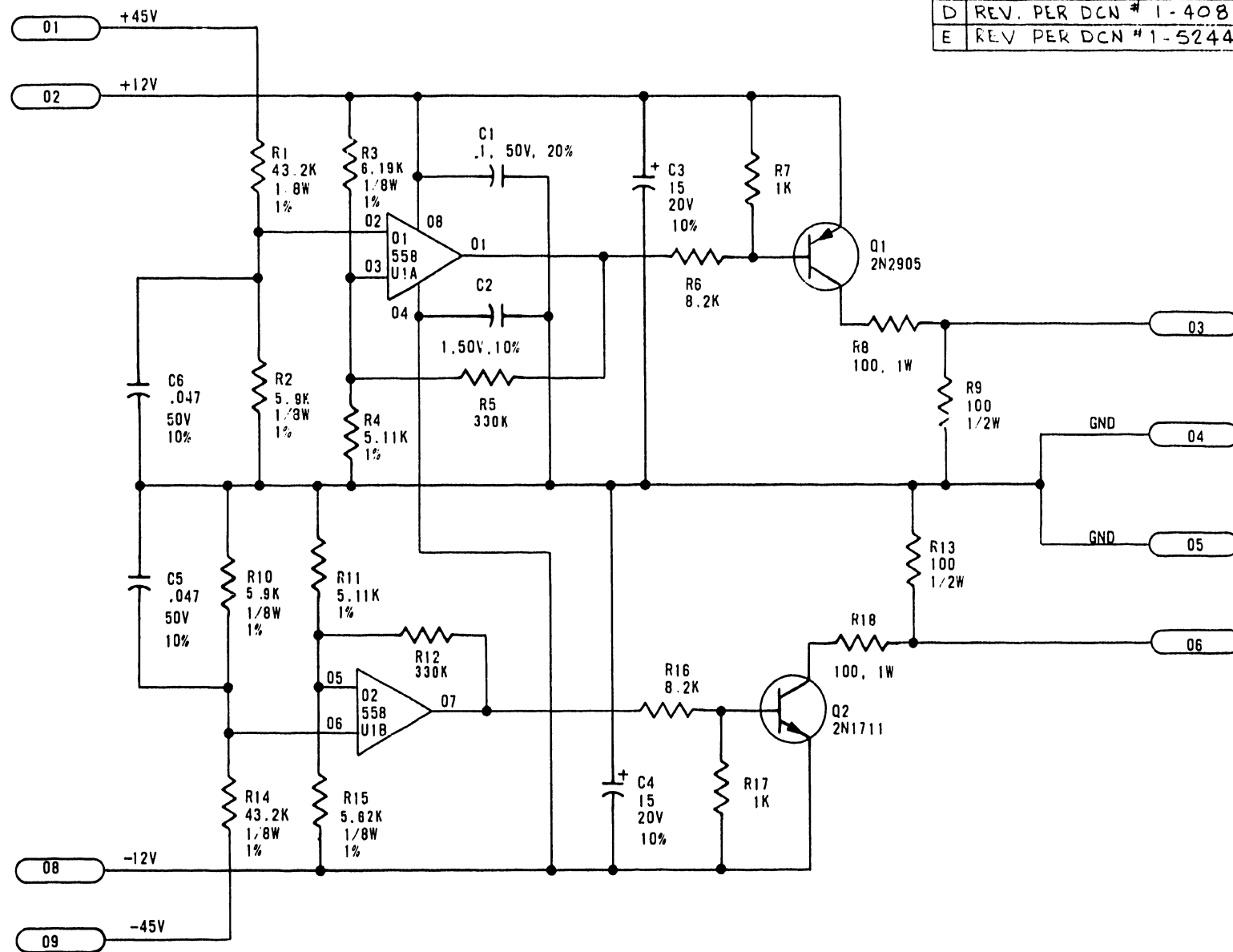

TOLERANCES	
UNLESS OTHERWISE SPECIFIED	
FRACTIONS	± 1/64
2 DECIMALS	.00 ± .010
3 DECIMALS	.000 ± .005
ANGULAR	± 30'
THREAD CLASS	NO. 2
HOLE DIAMETER	
DECIMAL	+ .005
	- .002
FRACTIONS	± 1/64

DRAWN	J.E. HEWITT	DATE	4/21/1977
CHECKED	[Signature]	DATE	4/29/77
APPROVED	[Signature]	DATE	4/30/77

TELEX
TULSA, OKLAHOMA

SCHEMATIC -
DUMP CIRCUIT

D91C71813-01		8020
C91C71813-01		5250/40
PART NUMBER	NEXT ASSEMBLY	USED ON
APPLICATION		

MATERIAL	
FINISH	

CODE IDENT NO.	SIZE	92C71813
SCALE	NONE	SHEET 1 OF 1

- NOTES:
1. RESISTANCE VALUES ARE IN OHMS, 1/4W, 5%
 2. CAPACITANCE VALUES ARE IN PICOFARADS, 200V, 10%
 3. [H] INDICATES COMPONENTS MOUNTED ON HEAT SINK.

DO NOT SCALE THIS PRINT

REV	DESCRIPTION	DATE	APP
-	PROTO RELEASE		
A	FO 196		
B	REL PER ERO #457-B	2-2-77	W. Cross
C	REL PER DCN #1-3212	11-7-77	W. Cross
D	REV PER DCN #1-3395	4-17-78	W. Cross
E	REV PER DCN #1-348	5-3-78	W. Cross
F	REV PER DCN #1-449-2	12-11-78	W. Cross

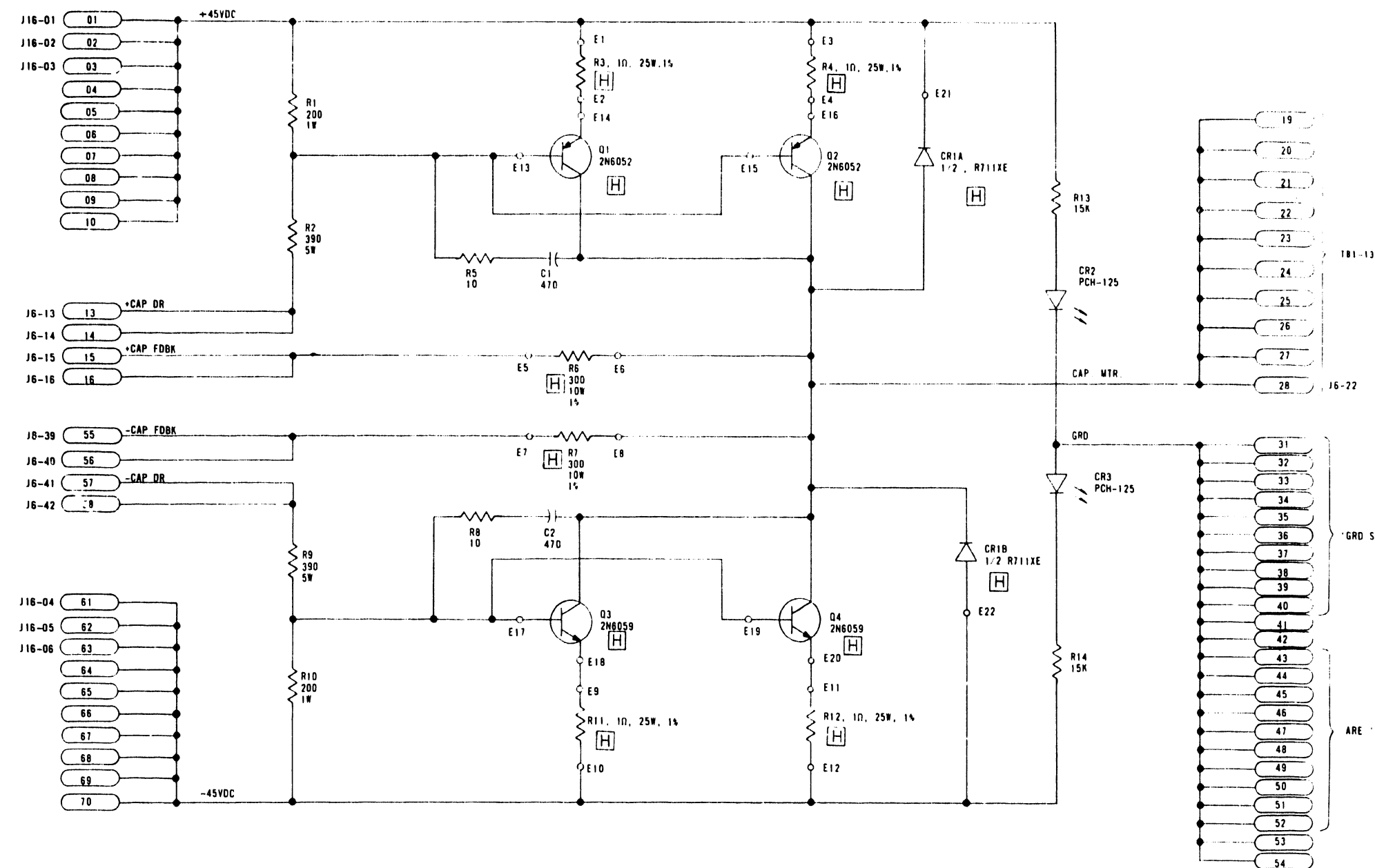

REF DESIGNATION	
LAST USED	NOT USED
Q4	
R14	
CR3	
C2	

TOLERANCES UNLESS OTHERWISE SPECIFIED FRACTIONS ± 1/64 DECIMALS ± 0.010 ANGULAR ± 30' HOLE DIAMETER ± 0.005 FRACTIONS ± 1/64		DRAWN F. CROSS CHECKED APPROVED W. Cross	DATE 4/24/77 DATE 5/5/77	SIZE 4 21 77	TELEX TULSA, OKLAHOMA
LOGIC DIAGRAM CAPSTAN POWER AMP A27					
PART NUMBER 92D71814-01		NEXT ASSEMBLY 6250/40		CODE IDENT NO D	SIZE 92D71814
APPLICATION					
SCALE 1:1					

- NOTES: UNLESS OTHERWISE SPECIFIED
1. 14 PIN I.C. - PIN 7 TO GROUND
- PIN 14 TO +5VDC
 2. 16 PIN I.C. - PIN 8 TO GROUND
- PIN 16 TO +5VDC
 3. RESISTORS ARE $\frac{1}{4}$ W, 5%, 1-BW ARE 1%
 4. CAPACITANCE VALUES ARE IN MICROFARADS. 50V, 20%
SEE JUMPER TABLE BELOW

DO NOT SCALE THIS PRINT

REVISIONS			
LTR	DESCRIPTION	DATE	APP
S	REV # REDRAWN PER DCN 1-5133-6	4-25-80	CE TXA
T	REV PER DCN # 1-5220	5-20-80	CE DNP
U	REV PER DCN # 1-5309	7-15-80	CE DPK
V	REV PER DCN 1-5404-2	10-14-80	CE TXA

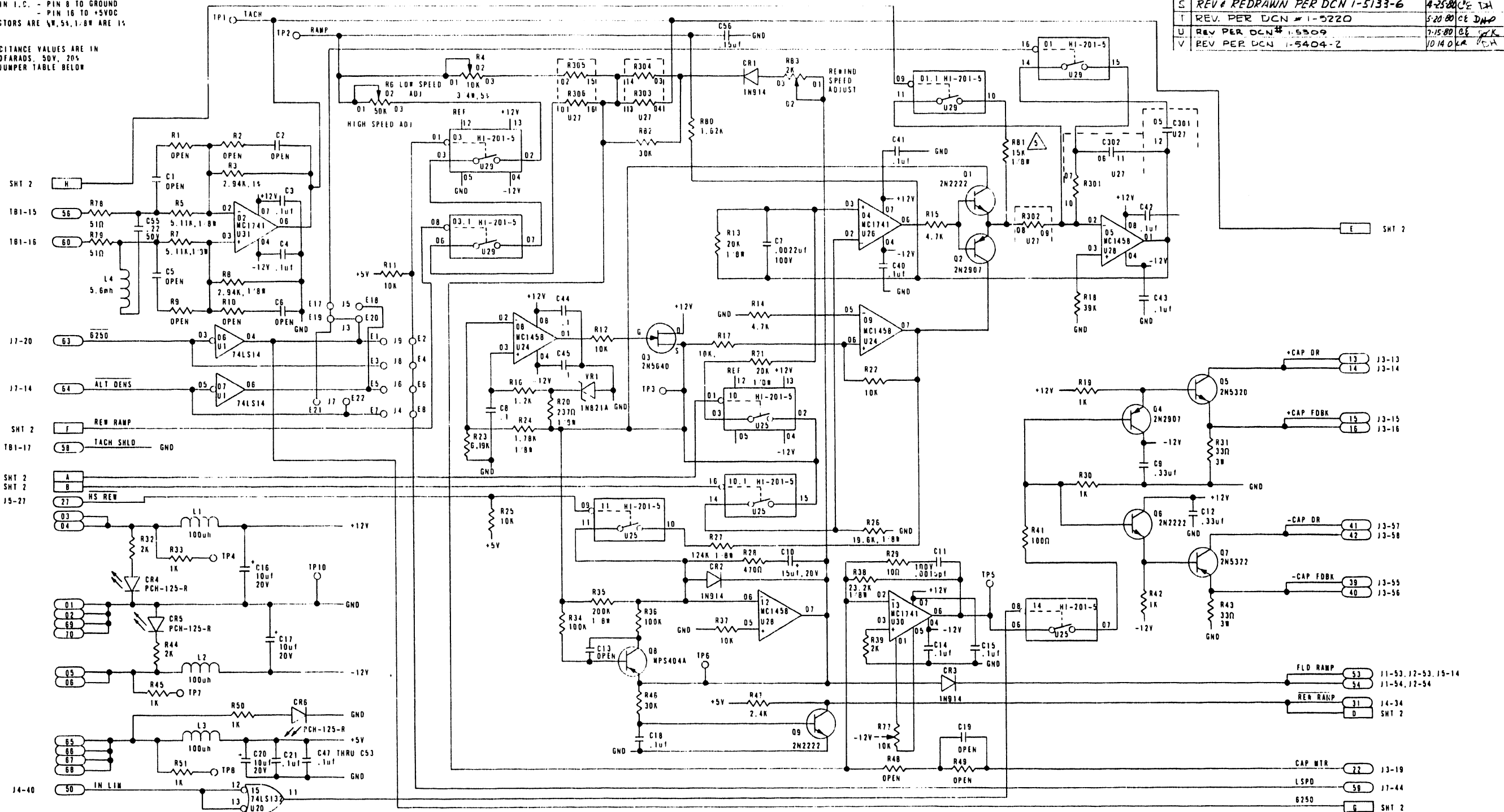

(REF 91022268)	SPEED MODULE OPTIONS								
DASH NO.	SPEED	R301	R302	R303	R304	R305	R306	C301	C302
-01	45 IPS	10K	84.5K	2.94K	3.40K	27K	OPEN	.068uF	.033uF
-02	75 IPS	6.2K	49.9K	2.94K	3.65K	15K	OPEN	.068uF	.027uF
-03	100 IPS	5.1K	35.7K	2.94K	3.92K	10K	OPEN	.068uF	.027uF
-04	125 IPS	3.6K	27.4K	2.94K	4.12K	8.8K	OPEN	.068uF	.027uF
-05	45 PE 75 HRZ	6.2K	84.5K	2.94K	3.40K	27K	36K	.033uF	.027uF
-06	75 GCR 125 PE	5.6K	48.4K	2.94K	3.65K	13.3K	9.1K	.027uF	.027uF
-07	75 PE 125 NRZ	3.6K	78.7K	2.94K	3.65K	13.3K	9.1K	.027uF	.033uF
-08	50 IPS	10K	95.3K	2.94K	3.40K	24K	OPEN	.068uF	.027uF

JUMPER TABLE												
VERSION	J1	J2	J3	J4	J5	J6	J7	J8	J9	J10	J11	R81
-01												
-02												
-03												
-04												

TOLERANCES UNLESS OTHERWISE SPECIFIED		DATE
DECIMALS	ANGULAR	3/27/80
XX ± 0	± 30	
XXX ± 0		
HOLE DIAMETER	-.005	
	-.002	
THREAD CLASS	NO 2	

REVISION	V	K			J6
SHEETS	1	2			

TELEX
TULSA, OKLAHOMA

LOGIC DIAGRAM
CAPSTAN PREAMP

B51C71827-04	6253
K91C71822-03	6750/40
R91C71822-02	6250/40
U91-71822-01	6253 6750/40
PART NUMBER	NEXT ASSEMBLY USED ON
APPLICATION	FINISH

CODE IDENT NO	SIZE
D	92D71822
SCALE NONE	LOC J6
	SHEET 1 OF 2

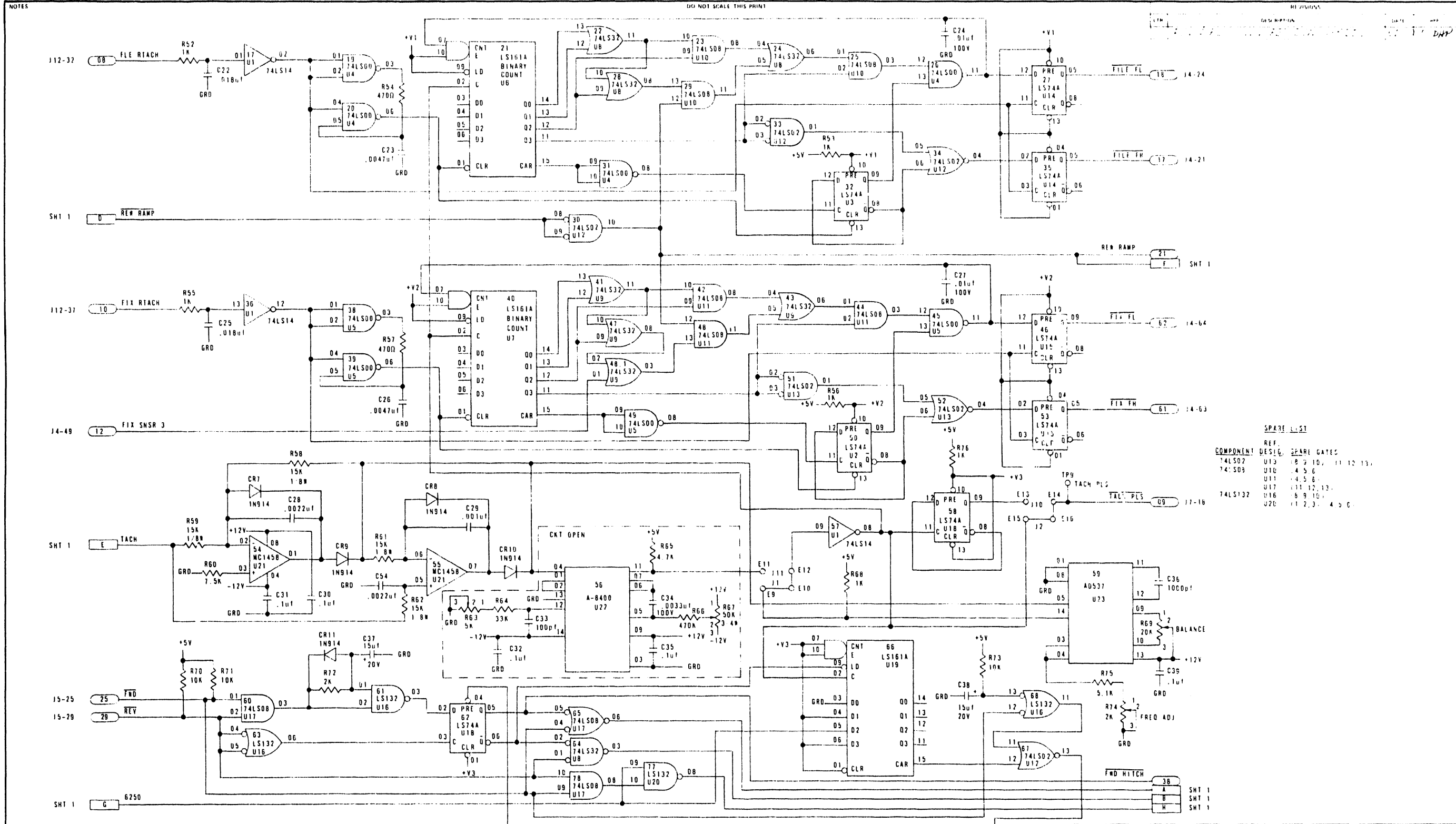

SPARE LIST

COMPONENT	REF. DESIG.	SPARE QTY	SPARE GATES
74LS02	U13	10	11 12 13
74LS08	U10	4	5 6
U11	4	5 6	
U17	11	12 13	
U16	6	9 10	
U20	1	2 3 4 5 6	

TOLERANCES UNLESS OTHERWISE SPECIFIED		DRAWN ECROSS		DATE	
DECIMALS XX : 0	ANGULAR XXX : 0	CHECKED	DATE	TELEX TULSA OKLAHOMA	
HOLE DIAMETER + .005	THREAD CLASS - .002	APPROVED <i>D. J. Hunt</i>	DATE 7/10/70	LOGIC DIAGRAM CAPSTAN PREAMP	
MATERIAL		CODE IDENT NO		SHEET	
SEE SHT 1		6250/40		D 92D71822	
PART NUMBER		NEXT ASSEMBLY USED ON		SCALE 100 V6	
APPLICATION		FINISH		SHEET 2 OF 2	

NOTES

1. ALL RESISTORS ARE 1/4W, 5%

DO NOT SCALE THIS PRINT

REVISIONS			
REV	DESCRIPTION	DATE	APP
D	REV. & REDRAWN PER DCIN # 1-4097-2	1-21-80	JF
E	REV. PER DCIN # 1-5109-2	1-5-80	III

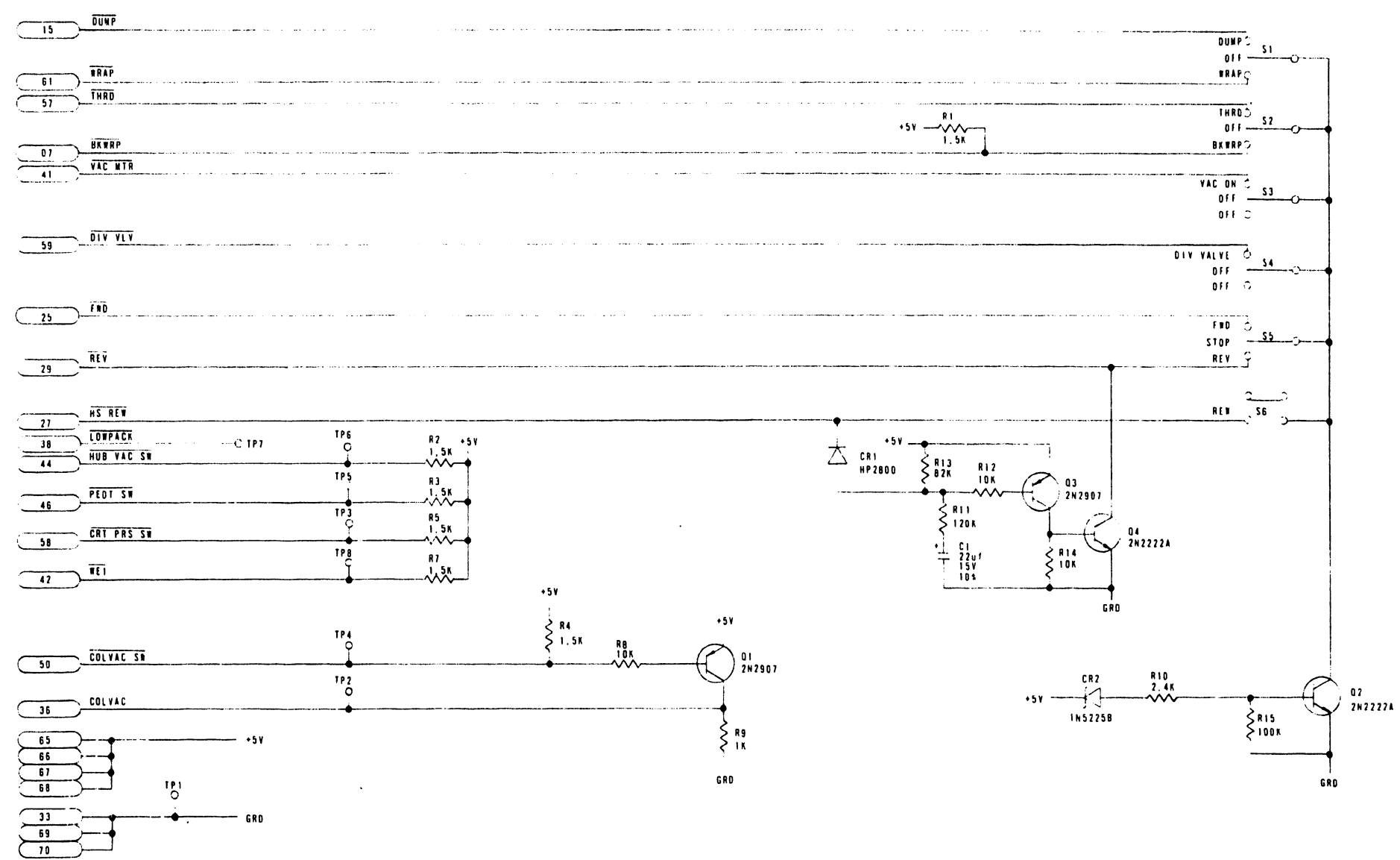

TOLERANCES UNLESS OTHERWISE SPECIFIED DECIMALS ± 0.10 ANGULAR ± 30° HOLE DIAMETER - 0.005 THREAD CLASS NO. 2		DRAWN F. CRÖE DATE 1/16/80	TELEX TULSA, OKLAHOMA
CHECKER C. E. JONES DATE 1/22/80	APPROVED J. M. ... DATE 1/22/80	SCHEMATIC DIAGRAM SWITCH BOARD	
MATERIAL:		CODE IDENT NO.	SIZE D
PART NUMBER: 92D71827-01		USED ON: 6250/40	SHEET OF

NOTES UNLESS OTHERWISE SPECIFIED:

- ALL I.C.'s 74---
- 14 PIN I.C. - CONNECT PIN 07 TO GRD
- CONNECT PIN 14 TO +5VDC
- 16 PIN I.C. - CONNECT PIN 08 TO GRD
- CONNECT PIN 16 TO +5VDC
- I.C. 74LS93 - CONNECT PIN 10 TO GRD
- CONNECT PIN 05 TO +5VDC
- ALL DIODES ARE 1N914
- RESISTANCE VALUES ARE IN OHMS, 1/4W, 5%
- CAPACITANCE VALUES ARE IN MICROFARADS, 100, 10K
- *SEE SPEED MODULE CHART

SEE FOR -07 CONDITION ONLY.

DO NOT SCALE THIS PRINT

REV	DESCRIPTION	DATE	APP
9	REV PER DCN # 5300	10/15/66	
11	REV PER DCN # 5301	10/15/66	
12	REV PER DCN # 5309	10/15/66	
13	REV PER DCN # 5300-B	10/15/66	

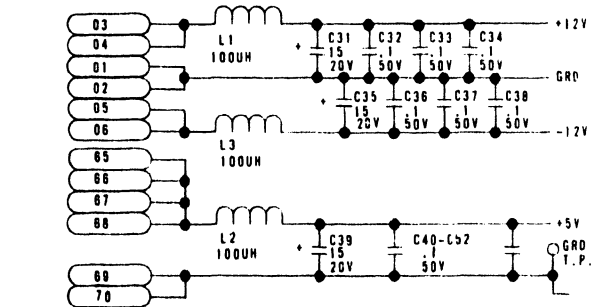
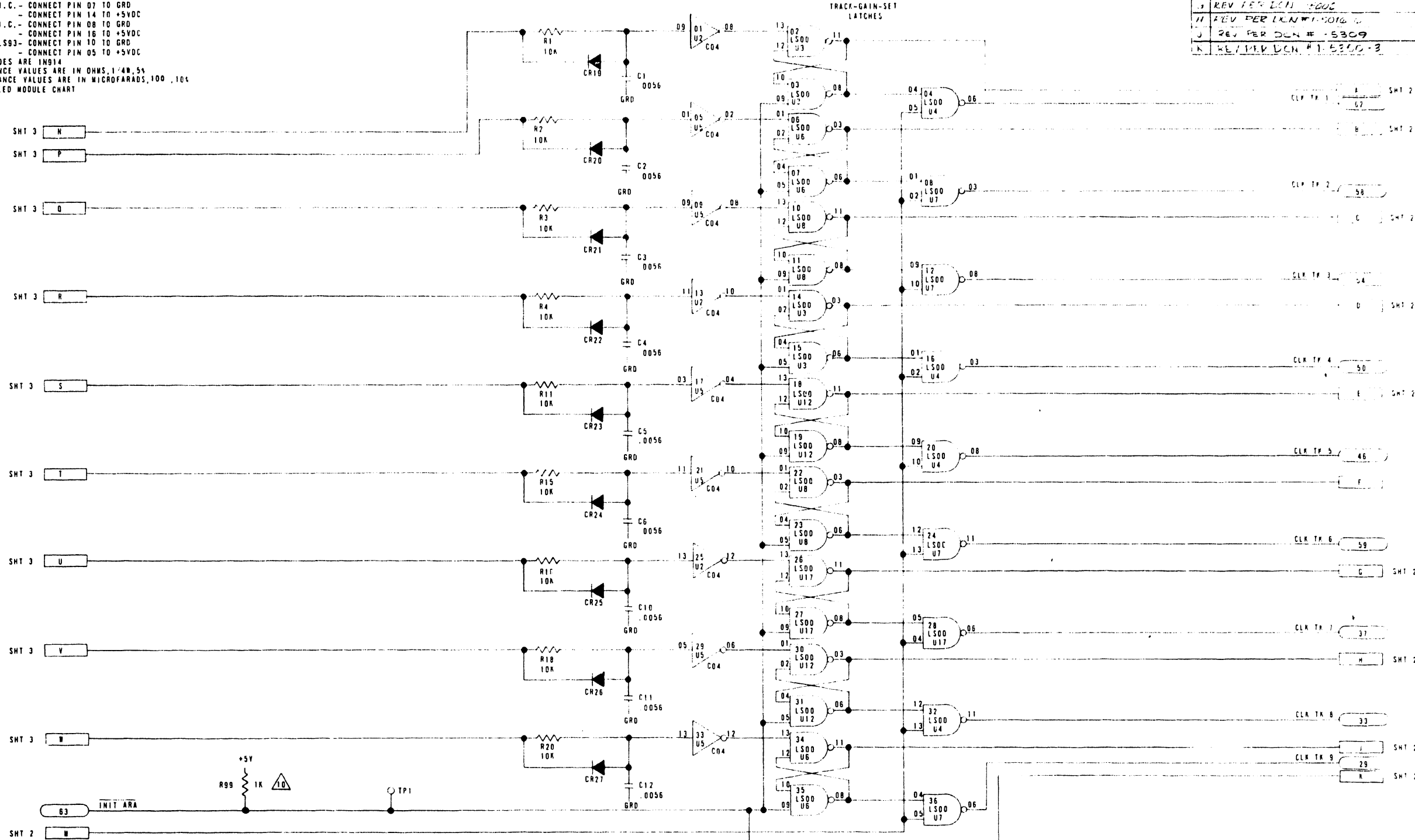

SPEED MODULE CHART

DASH NO.	ALT PICK	R12	DROP	PICF	ALT DROP	CR28-45	JUMPER COMPONENT
	R87, 84, 86, 88, 90, 92, 94, 96, 98		R21, 26, 33, 38, 45, 50, 57, 62, 69	R22, 27, 34, 39, 46, 51, 58, 63, 70	R81, 83, 85, 87, 89, 91, 93, 95, 97		
-1(45 or 50)ps		49.9K	20.5K	37.4K			
-2(75)ps		28.7K	12.4K	22.6K			
-4(125)ps		15.0K	7.87K	13.7K			
-6(125PE, 756CR)	32.4K	28.7K	12.4K	22.6K	22.6K	1N914	72
-7(75)ps, T.I.		28.7K	22.6K	37.4K			

89D71830-07	6250/11
89D71830-06	6250/40
89D71830-0A	6250/4C
89D71830-02	6250/4G
89D71830-01	6250/4Q

TOLERANCES
UNLESS OTHERWISE SPECIFIED:
FRACTIONS 1/64
DECIMALS .005
ANGULAR HOLE DIAMETER .005
DECIMAL FRACTIONS .005

DRAWN FCROSS
CHECKED
APPROVED
DATE 7/2/68

REVISION 0 B
SHEETS 1 2 3 J9

TELEX
TULSA, OKLAHOMA

LOGIC DIAGRAM
AGC & AMP SENSE

CODE IDENT NO. **D**
SIZE 92D71830
SHEET 3 OF 3

NOTES

DO NOT SCALE THIS PRINT

REV	DESCRIPTION	DATE	APP
C	REV & REDRAWN PER DCN #1-3535	10-11-78	46 CA
D	REV PER DCN #1-5033-3	2-15-80	66 T-1
E	REV PER DCN #1-5350-4	2-17-81	46 CA

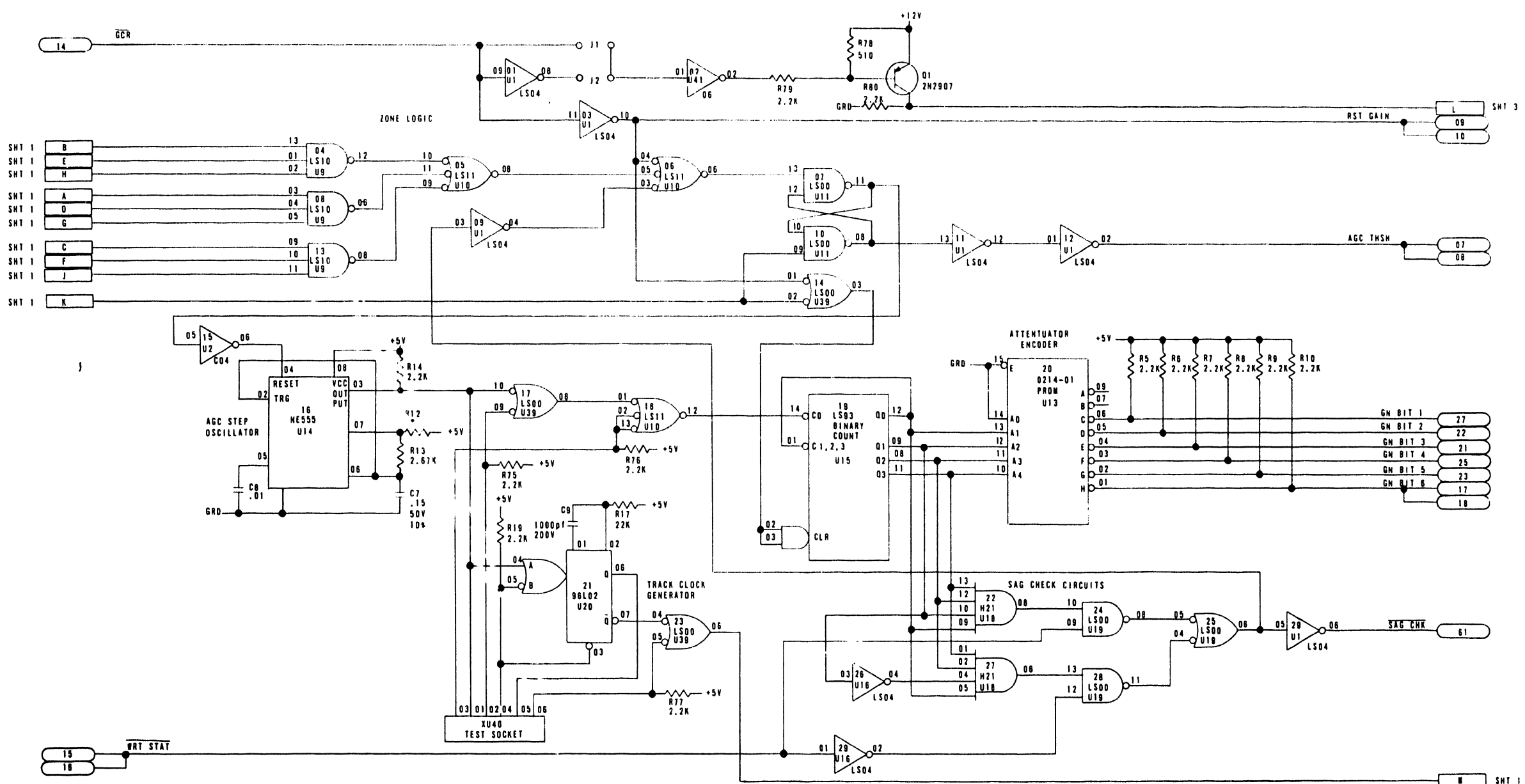

SPARE GATES		
COMPONENT	REF. DESIG.	GATES
74LS00	U11	(01, 02, 03), (04, 05, 06)
	U17	(01, 02, 03)
	U18	(01, 02, 03)
	U39	(11, 12, 13)
74LS04	U16	(05, 06), (08, 09), (10, 11), (12, 13)
74C04	U2	(01, 02), (03, 04)
7408	U41	(03, 04), (05, 06), (08, 09), (10, 11), (12, 13)
96L02	U20	(09, 10, 11, 12, 13, 14, 15)

TOLERANCES DIMENSIONS UNLESS OTHERWISE SPECIFIED FRACTIONS ± 1/64 DECIMALS ± .010 ANGULAR ± .90° HOLE DIAMETER ± .008 FRACTIONS ± 1/64	DRAWN F. CROSS DATE 7/21/78	TELEX TULSA, OKLAHOMA LOGIC DIAGRAM AGC & AMP SENSE
	CHECKED <i>P. Edwards</i> DATE 10/23/78	
MATERIAL		CODE IDENT NO D
PART NUMBER 6250/40		SIZE 92D71830
APPLICATION		SCALE 2 OF 3

NOTES

DO NOT SCALE THIS PRINT

REVISIONS		DATE	APP
A	REL PER DCN #1-3535	3-3-78	CH
B	REV PER DCN #1-5131	3-17-80	LK (E)

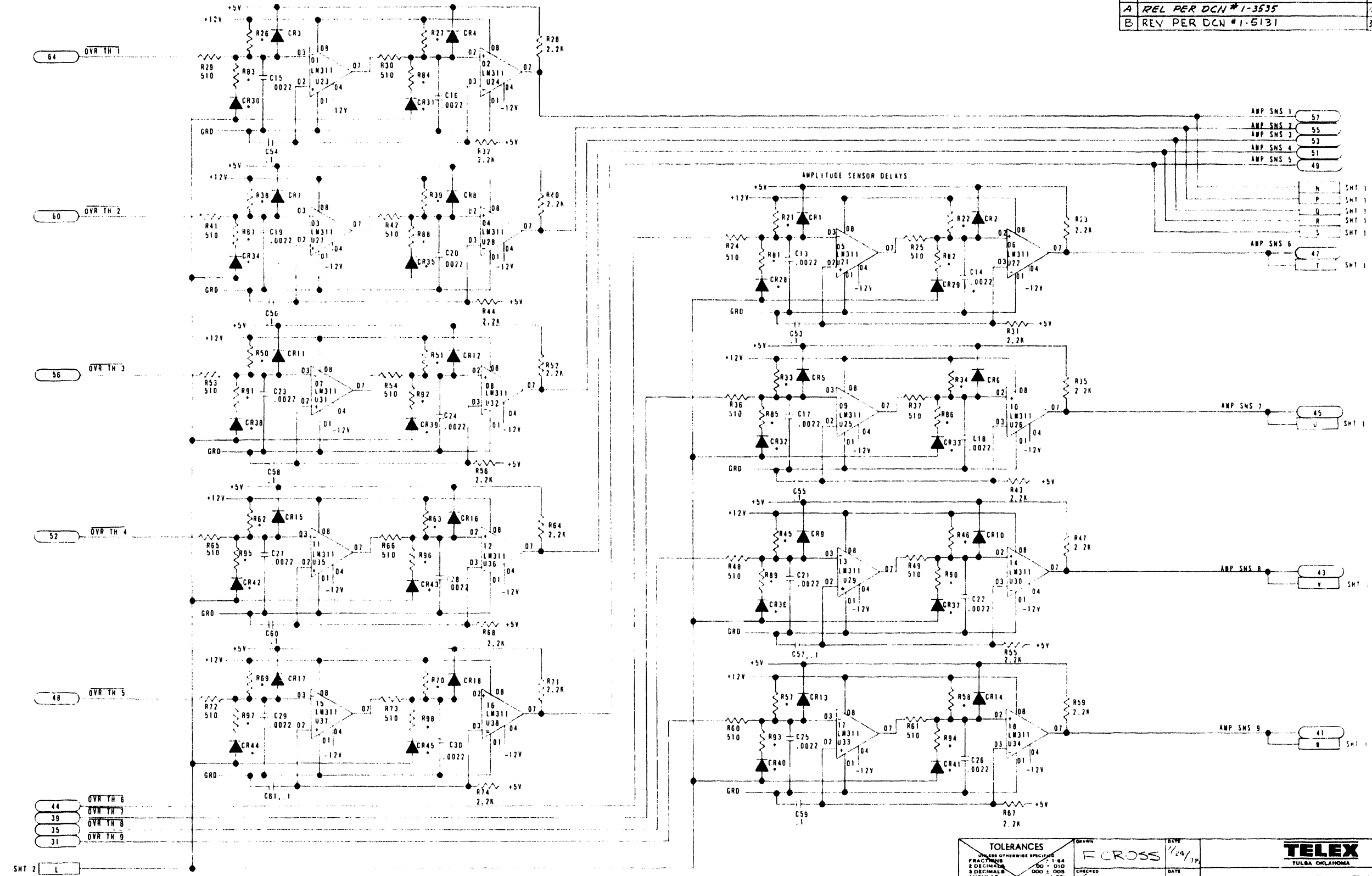

- 64 OVR TH 1
- 60 OVR TH 2
- 56 OVR TH 3
- 52 OVR TH 4
- 48 OVR TH 5
- 44 OVR TH 6
- 39 OVR TH 7
- 35 OVR TH 8
- 31 OVR TH 9

- AMP SNS 1 57
- AMP SNS 2 55
- AMP SNS 3 53
- AMP SNS 4 51
- AMP SNS 5 49
- AMP SNS 6 47
- AMP SNS 7 45
- AMP SNS 8 43
- AMP SNS 9 41

TOLERANCES UNLESS OTHERWISE SPECIFIED FRACTIONS ± 1/64 DECIMALS ± 0.10 3 DECIMALS ± 0.005 ANGULAR ± 30' NO. 8 THREAD CLASS HOLE DIAMETER ± 0.005 DECIMAL ± 0.002 FRACTIONS ± 1/64	DRAWN F CROSS	ESTD 1/24/78	TELEX TULSA OKLAHOMA LOGIC DIAGRAM AGC & AMP SENSE
	CHECKED <i>[Signature]</i>	DATE 3/29/78	
MATERIAL	FINISH	PART NUMBER 92571830	SHEET 3 OF 3

PART NUMBER	92571830
APPROVED	[Signature]
DATE	3/29/78

NOTES:

DO NOT SCALE THIS PRINT

REV	DESCRIPTION	DATE	APP
1A	REL PER DCU #		
1B	REL PER DCU #		

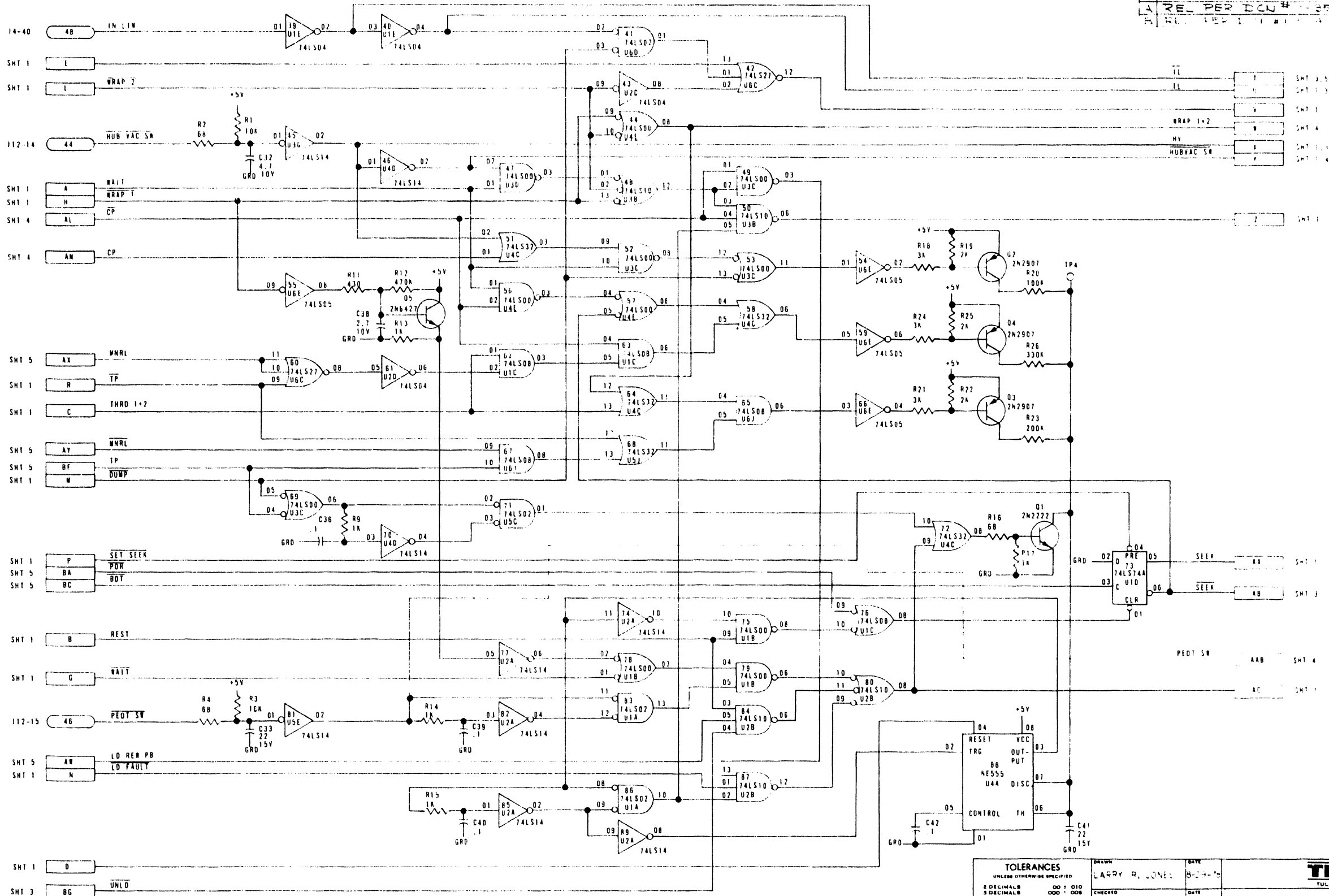

TOLERANCES		UNLESS OTHERWISE SPECIFIED	DRAWN	DATE
2 DECIMALS	001	010	LARRY R. JONES	8-24-75
3 DECIMALS	000	008		
ANGULAR		± 30'		
THREAD CLASS		NO 2		
HOLE DIAMETER		± 0.0005		
DECIMAL		± 0.003		

CHECKED	DATE	
APPROVED	DATE	

MATERIAL	CODE IDENT NO.	SIZE
		D

APPLICATION	REVISIONS
	CONTROL LOG

NOTES:
 SMT 1 R YP
 SMT 2 X HV
 SMT 2 U IL
 SMT 4 AH UNLD L1
 SMT 5 AZ POR
 SMT 2 AB SEEK
 SMT 3 AJ REV
 17-08 16 REM FWD
 SMT 4 AU LCL FWD
 SMT 5 BB EOT
 17-07 16 REM REV
 SMT 4 AT LCL REV
 17-42 20 ERSWD
 SMT 5 BD BOT
 SMT 3 AH TSTR SET
 SMT 2 Y IL
 SMT 4 AS DISAB
 114-03 10 ON LN PB
 SMT 4 AR AC TRIG
 SMT 5 AV LD/REV PB
 17-08 28 REM REV
 112-01 38 LOW PACK
 17-10 30 REM UNLD
 114-05 34 UNLD PB
 SMT 1 G WAIT
 SMT 1 M LD FAULT
 SMT 8 AX UNRL
 SMT 8 BE FPLD
 18-21 21 REV RAMP

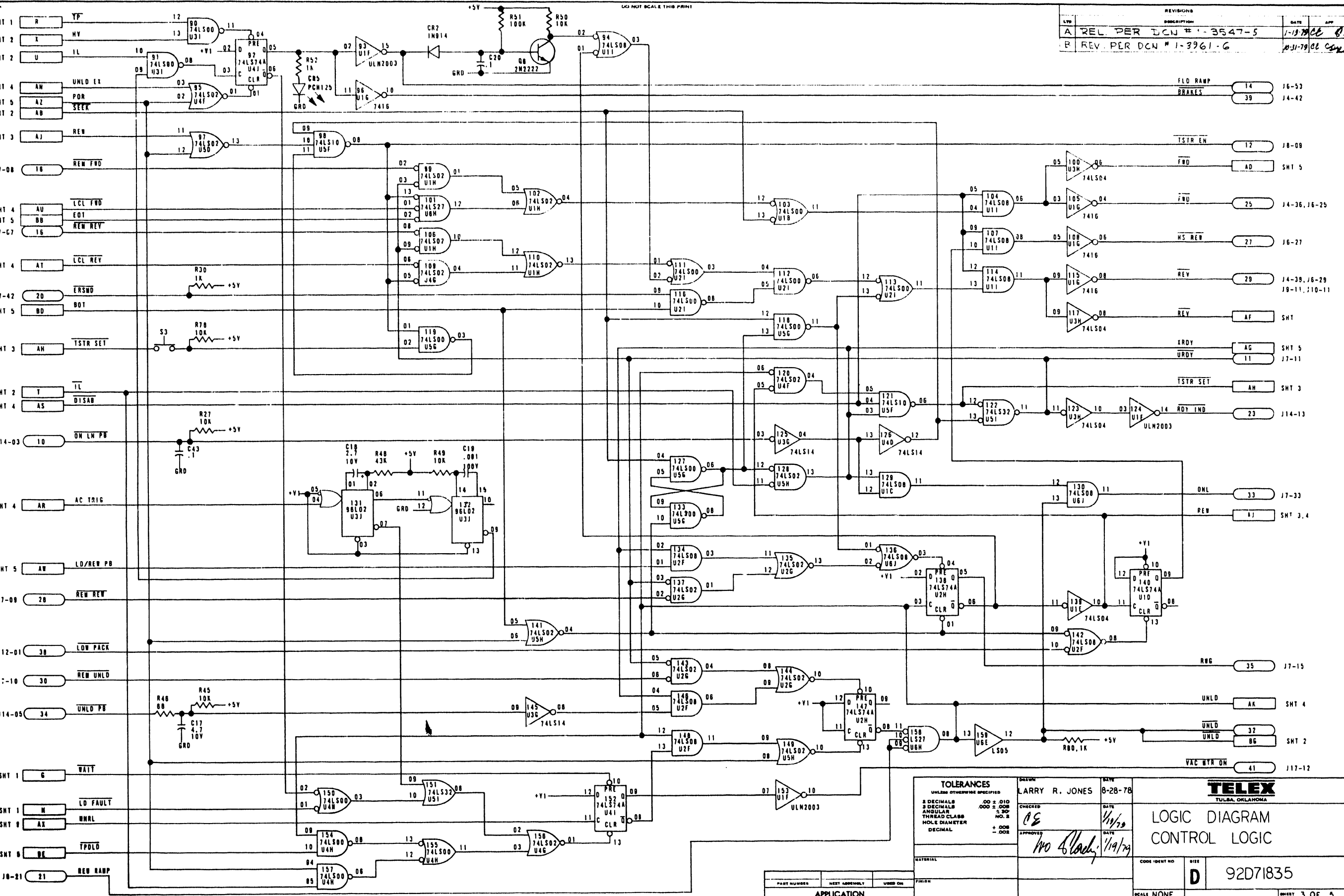

REV	DESCRIPTION	DATE	APP
A	REL PER DCN # 1-3547-5	1-19-78	CS
B	REV PER DCN # 1-3961-6	10-31-79	CS

FLO RAMP	14	16-53
BRKES	39	14-42
TSTR EN	12	18-09
FWD	AD	SMT 5
FWD	25	14-36, 16-25
HS REV	27	16-27
REV	29	14-38, 16-29
RELY	AF	SMT
XRDY	AG	SMT 5
URDY	11	17-11
TSTR SET	AH	SMT 3
RDY IND	23	114-13
DNL	33	17-33
REV	41	SMT 3, 4
RNG	35	17-15
UNLD	AK	SMT 4
UNLD	32	SMT 2
UNLD	BG	SMT 2
VAC WTR ON	41	117-12

TOLERANCES		DRAWN		DATE	
UNLESS OTHERWISE SPECIFIED		LARRY R. JONES		8-28-78	
3 DECIMALS	± 0.10	CHECKED		DATE	1/19/79
2 DECIMALS	± 0.05	APPROVED		DATE	1/19/79
ANGULAR	± 30'	TELEX TULSA, OKLAHOMA			
THREAD CLASS	NO. 3	LOGIC DIAGRAM CONTROL LOGIC			
HOLE DIAMETER	± 0.02	CODE IDENT NO			
DECIMAL	± 0.02	D 92D71835			
MATERIAL		SCALE		NONE	
APPLICATION		INVEST		3 OF 5	

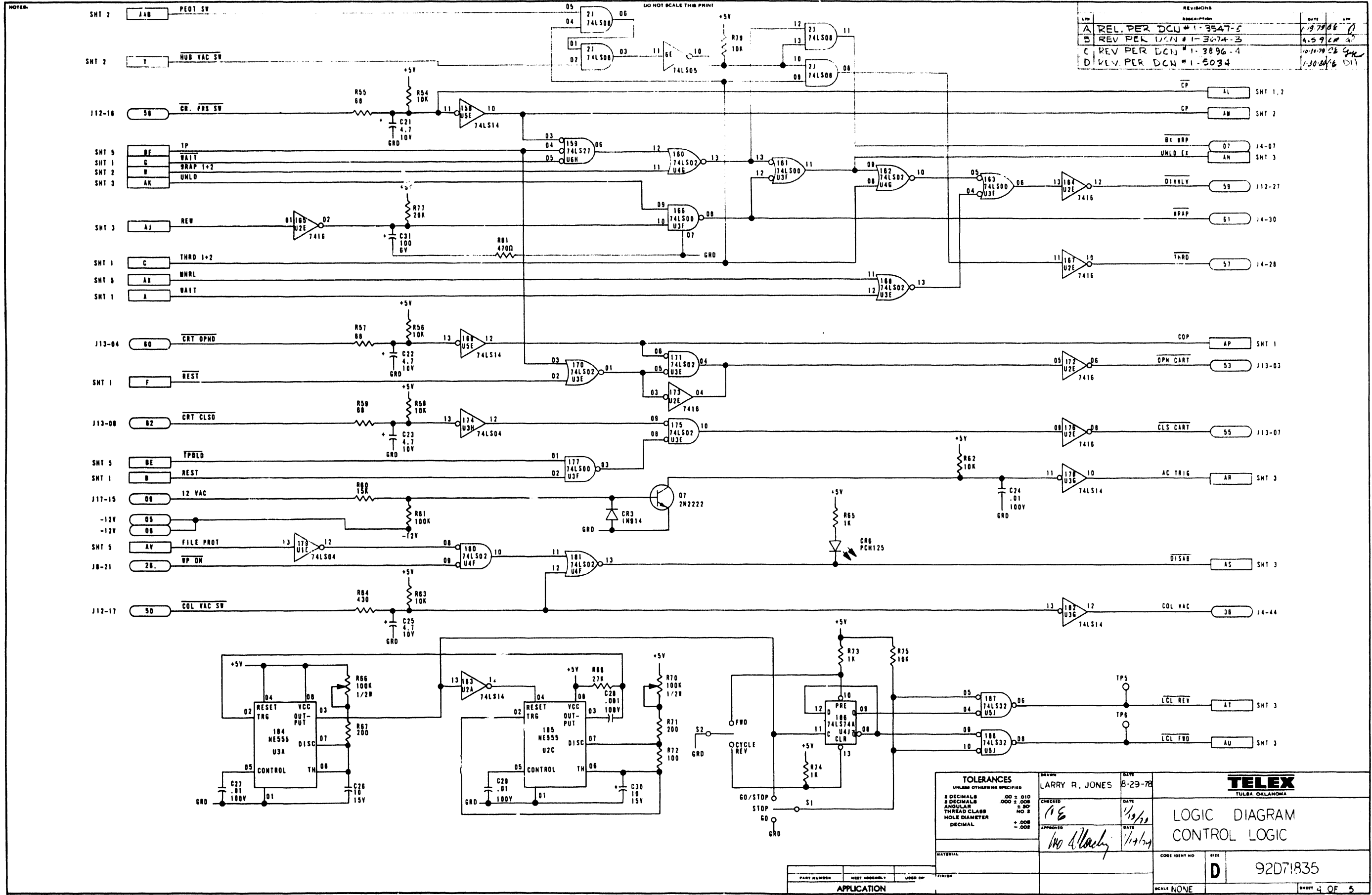

REV	DESCRIPTION	DATE	BY
A	REL. PER DCN # 1-3547-5	1-19-78	DR
B	REV PER DCN # 1-3674-3	4-5-78	DR
C	REV PER DCN # 1-3896-4	10-31-78	DR
D	REV PER DCN # 1-5034	1-30-81	DR

TOLERANCES		UNLESS OTHERWISE SPECIFIED
2 DECIMALS	± .010	
3 DECIMALS	± .005	
ANGULAR	± .30°	
THREAD CLASS	NO 3	
HOLE DIAMETER	+ .008	
DECIMAL	- .008	

DRAWN LARRY R. JONES 8-29-78 CHECKED 1/8 1/19/79 APPROVED 1/10/79	TELEX TULSA OKLAHOMA LOGIC DIAGRAM CONTROL LOGIC CODE IDENT NO D 92D71835 SCALE NONE SHEET 4 OF 5
--	---

PART NUMBER	NEXT ASSEMBLY	USED ON	FINISH
APPLICATION			

NOTES:

DO NOT SCALE THIS PRINT

NOTES:

DO NOT SCALE THIS PRINT

REVISING

DATE 8/29/78

DESCRIPTION

A. KEL PER DCN # 3547'S

P. FSV PER DCN # 1-0461

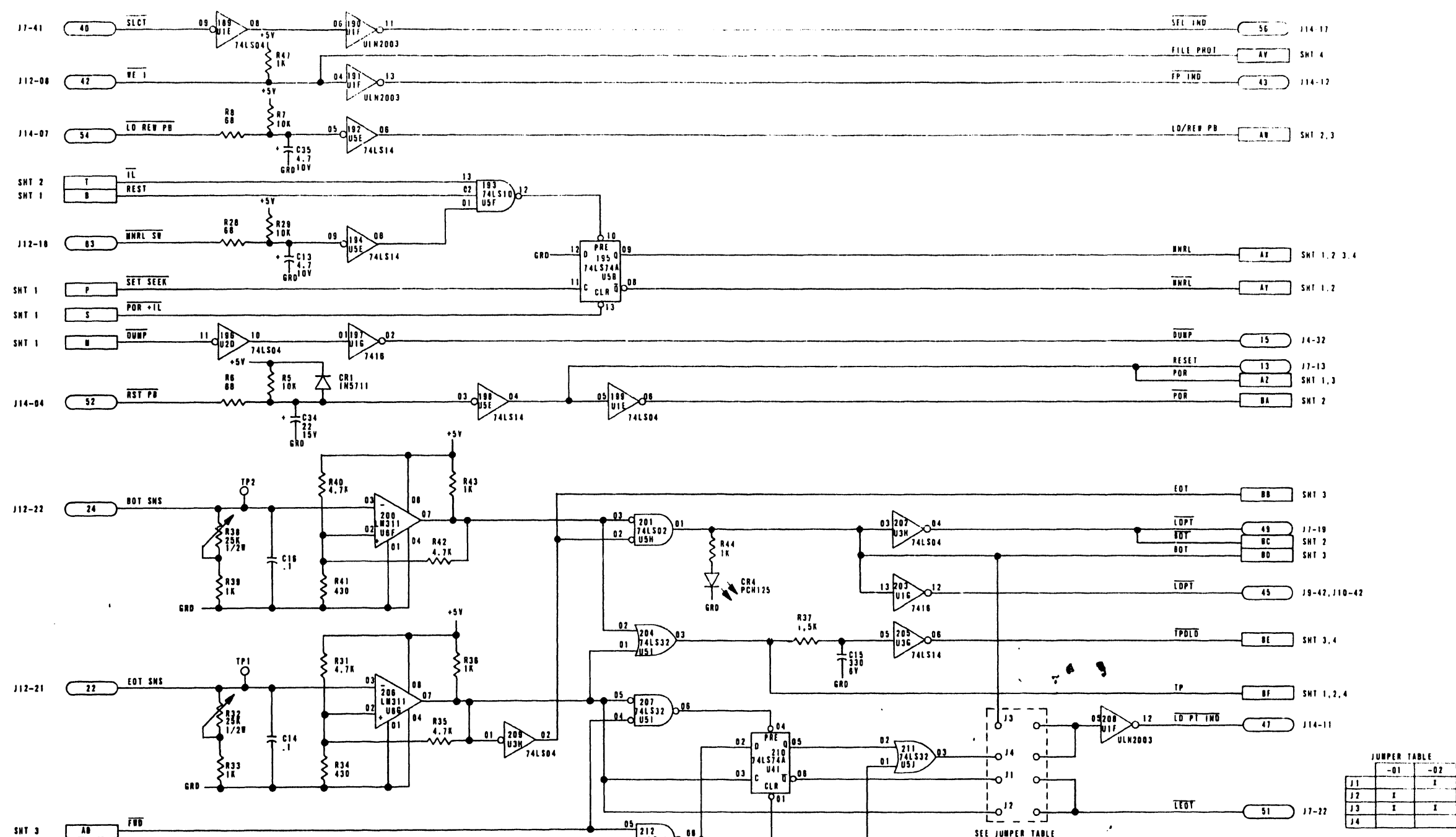

JUMPER TABLE

	-01	-02
J1		X
J2	X	
J3	X	X
J4		

TOLERANCES
UNLESS OTHERWISE SPECIFIED

2 DECIMALS .00 ± .010
3 DECIMALS .000 ± .005
ANGULAR ± .50°
THREAD CLASS NO. 2
HOLE DIAMETER + .005
DECIMAL - .005

DESIGN LARRY R. JONES DATE 8-29-78
CHECKED O.E. DATE 11/9/78
APPROVED W.D. Black DATE 11/9/78

TELEX
TULSA, OKLAHOMA

LOGIC DIAGRAM
CONTROL LOGIC

MATERIAL

CODE IDENT NO. DATE
D 92D71835

SCALE NONE SHEET 5 OF 5

SEE SH1 1

APPICATION

NOTES

DO NOT SCALE THIS PRINT

REVISIONS			
LTR	DESCRIPTION	DATE	APP
A	REL PER ERO 457-33	2-6-79	L.R. Jones
B	REV PER DCN 1-4045	1-3-80	L.R. Jones

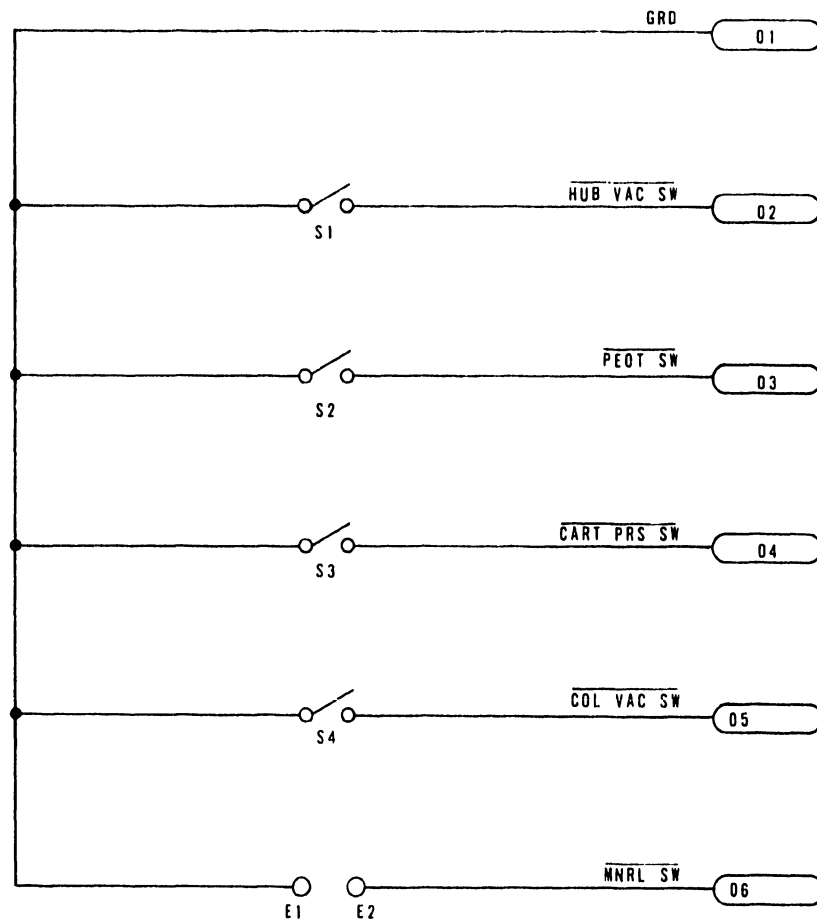

A91C71837-01	6250/40
PART NUMBER	USED ON

APPLICATION

TOLERANCES UNLESS OTHERWISE SPECIFIED 2 DECIMALS .00 ± .010 3 DECIMALS .000 ± .005 ANGULAR ± 30' THREAD CLASS NO. 2 HOLE DIAMETER + .005 DECIMAL - .002	DRAWN LARRY R. JONES	DATE 2-1-79	TELEX TULSA, OKLAHOMA
	CHECKED <i>K. Jones</i>	DATE 2-3-79	
MATERIAL	APPROVED <i>L.R. Jones</i>	DATE 2-6-79	CODE IDENT NO.
			SIZE C
			92C71837
			SCALE NONE
			SHEET 1 OF 1

NOTES:

1. RESISTANCE VALUES ARE IN OHMS, 1/4 WATT, 5%.
2. CAPACITANCE VALUES ARE MICROFARADS.
3. 14 PIN I.C. CONNECT PIN 07 TO GRD. CONNECT PIN 14 TO +5V.

DO NOT SCALE THIS PRINT

REVISIONS

ITR	DESCRIPTION	DATE	APP
A	KEL PER ERO # 457-46	8-27-79	LR EK
B	REV PER DCN # 1-4040-2	12-14-79	LR (18)
C	REV PER DCN # 1-5013-2	1-22-80	LR

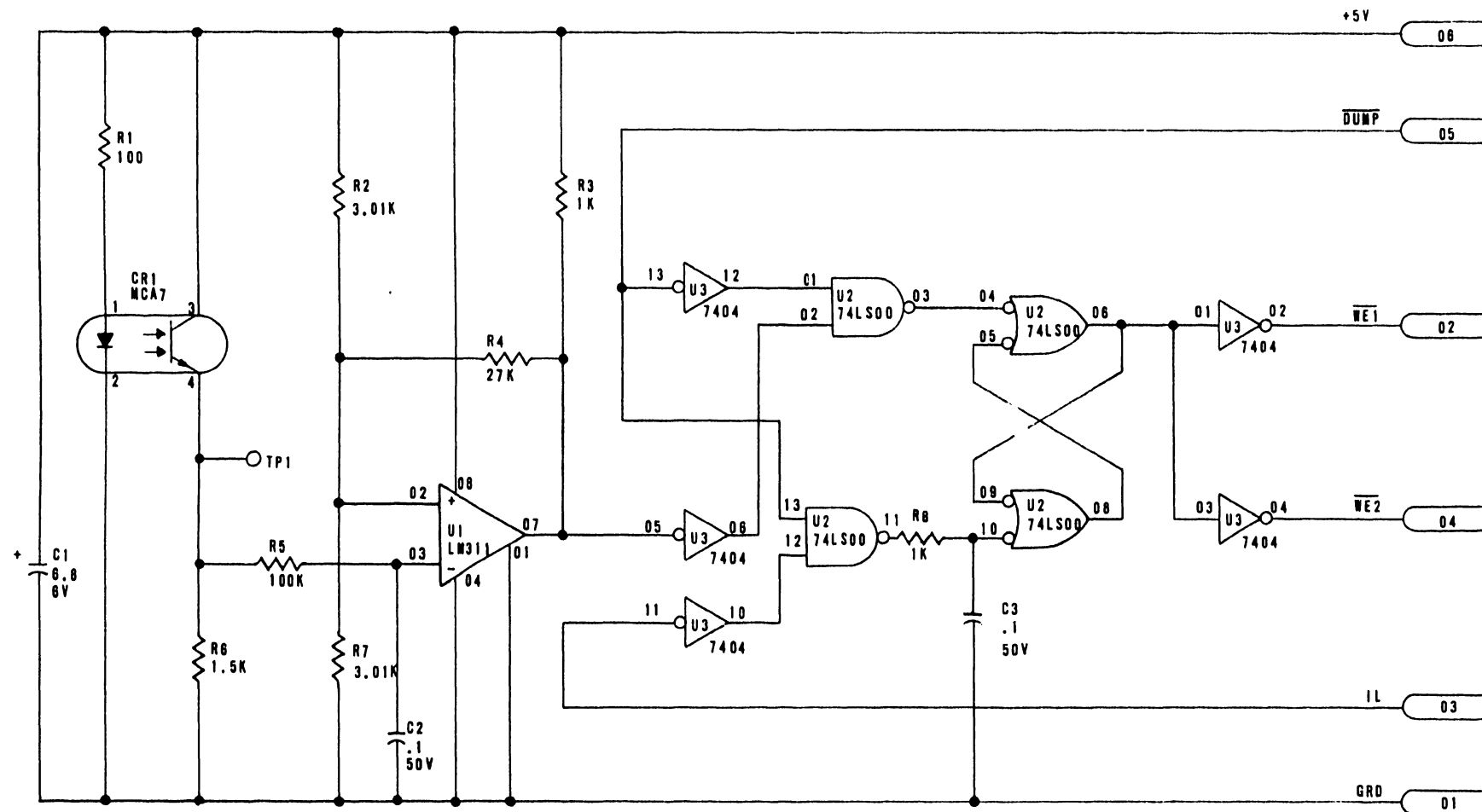

REFERENCE DESIGNATIONS	
LAST USED	NOT USED
U3	
CR1	
R8	
C3	
TP1	

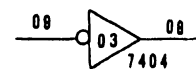

TOLERANCES UNLESS OTHERWISE SPECIFIED DECIMALS .XX ± 0 .XXX ± 0 HOLE DIAMETER +.005 -.002 THREAD CLASS NO. 2		DRAWN <i>Randolph</i> DATE 7/13/79	TELEX TULSA, OKLAHOMA SCHEMATIC, WRITE ENABLE
MATERIAL 8020 6250/40		CHECKED LR 8-27-79 DATE	
PART NUMBER C91C71839-01 C91C71839-01		APPROVED <i>Don Horn</i> DATE	CODE IDENT NO. SIZE C
APPLICATION		SCALE NONE	SHEET 1 OF 1

- UNLESS OTHERWISE SPECIFIED:
- 14 PIN I.C. - CONNECT PIN 07 TO GRD.
 - 16 PIN I.C. - CONNECT PIN 14 TO +5VDC.
 - RESISTANCE VALUES ARE IN OHMS. 1/4W ARE 5%.
 - CAPACITANCE VALUES ARE IN MICROFARADS 100V, 10%.
SEE SCHEDULE BELOW.

DO NOT SCALE THIS PRINT

REVISIONS			
REV	DESCRIPTION	DATE	APP
D	REV PER DCN # 1-5051	2-12-80	DK
E	REV PER DCN # 1-5133-5	4-22-80	DK
F	REV PER DCN 1-5250-3	6-9-80	DK
G	REV PER DCN 1-5312	7-15-80	DK
H	REV PER DCN 1-5350-3	10-14-80	DK
I	REV PER DCN 1-5378-3	11-10-80	DK

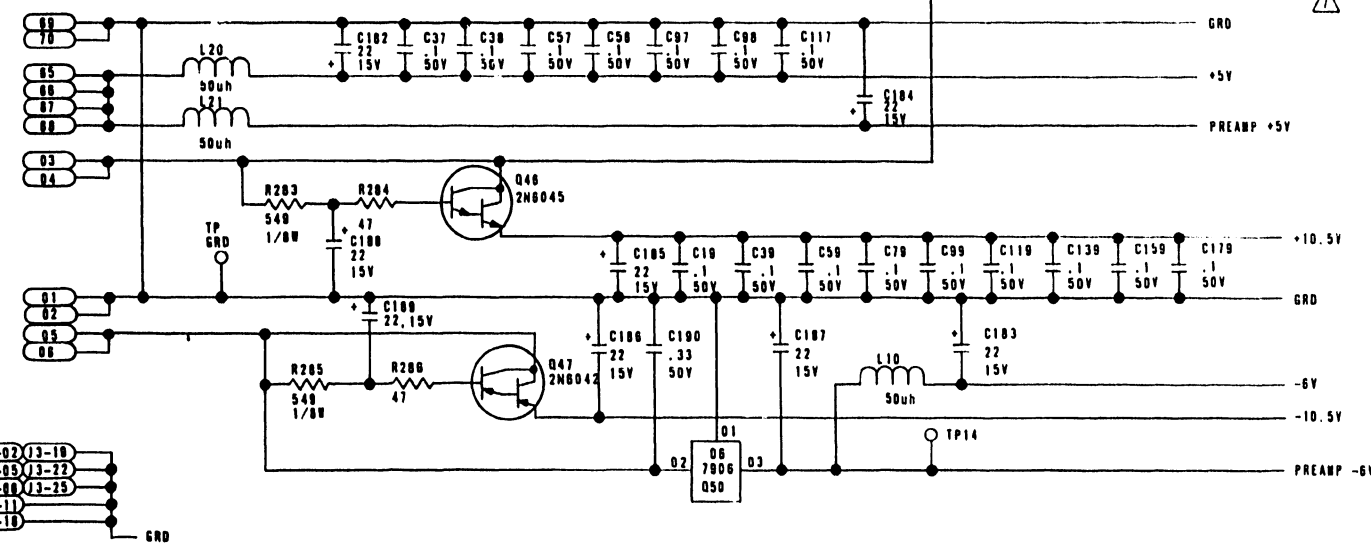
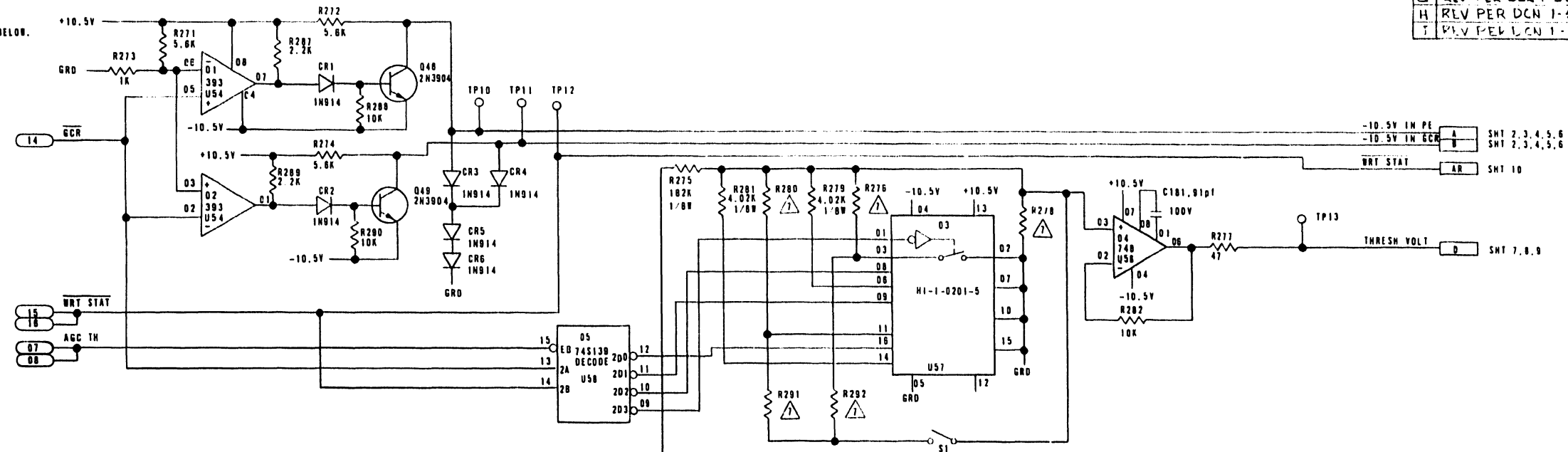

COMPONENT	SPARE LIST	REF DESIG	SPARES
74LS139	U58	01, 02, 03, 04, 05, 06, 07	
74LS02	U48	08, 09, 10	

REF DESIG	
LAST USED	NOT USED
C100	
CR6	
L21	
Q50	
R280	
TP14	
U51	U55, U59

MODEL	C3, 23, 43, 63, 83, 103, 123, 143, 163	C8, 28, 48, 68, 88, 108, 128, 148, 168	C7, 27, 47, 67, 87, 107, 127, 147, 167	C6, 26, 46, 66, 86, 106, 126, 146, 166, 186, 196, 206	C10, 30, 50, 70, 90, 110, 130, 150, 170, 190, 210, 230, 250	R8, 38, 68, 98, 128, 158, 188, 218, 248	R9, 39, 69, 99, 129, 159, 189, 219, 249	L1-9	L11-10
-01 (50 IPS)	.0056	.0002	.0047	300pf	.0018	100	33	500uh	220uh
-02 (75 IPS)	.0056	.01	.0047	200pf	.0022	100	33	300uh	82uh
-04 (125 IPS)	.0022	.0047	.0022	120pf	.001	133	56	220uh	50uh
-06 (50 IPS)	.0056	.0002	.0047	300pf	.0018	100	33	500uh	220uh
-07 (75 IPS)	.0056	.01	.0047	200pf	.0022	100	33	300uh	82uh
-09 (125 IPS)	.0022	.0047	.0022	120pf	.001	133	56	220uh	50uh

PART NUMBER	NEXT ASSEMBLY	USED ON
A 9127201-09		G253
A 9127201-07		
A 9127201-06		
C 9127201-04		
E 9127201-01		

REVISION	J	C	C	C	C	C	C	C	D	J10
SHEETS	1	2	3	4	5	6	7	8	9	10

TELEX
TULSA, OKLAHOMA

LOGIC DIAGRAM
PE-GCR READ

DATE: 1-25-80
DRAWN: W. TAYLOR
CHECKED: C. Edwards
DATE: 2/1/80
APPROVED: D. HENDERSON
DATE: 2-15-80

92D72201

SHEET 1 OF 10

NOTES

DO NOT SCALE THIS PRINT

REVISIONS		DATE	APP
C1	REV PER DCN #1-6051	1/12/80	DM

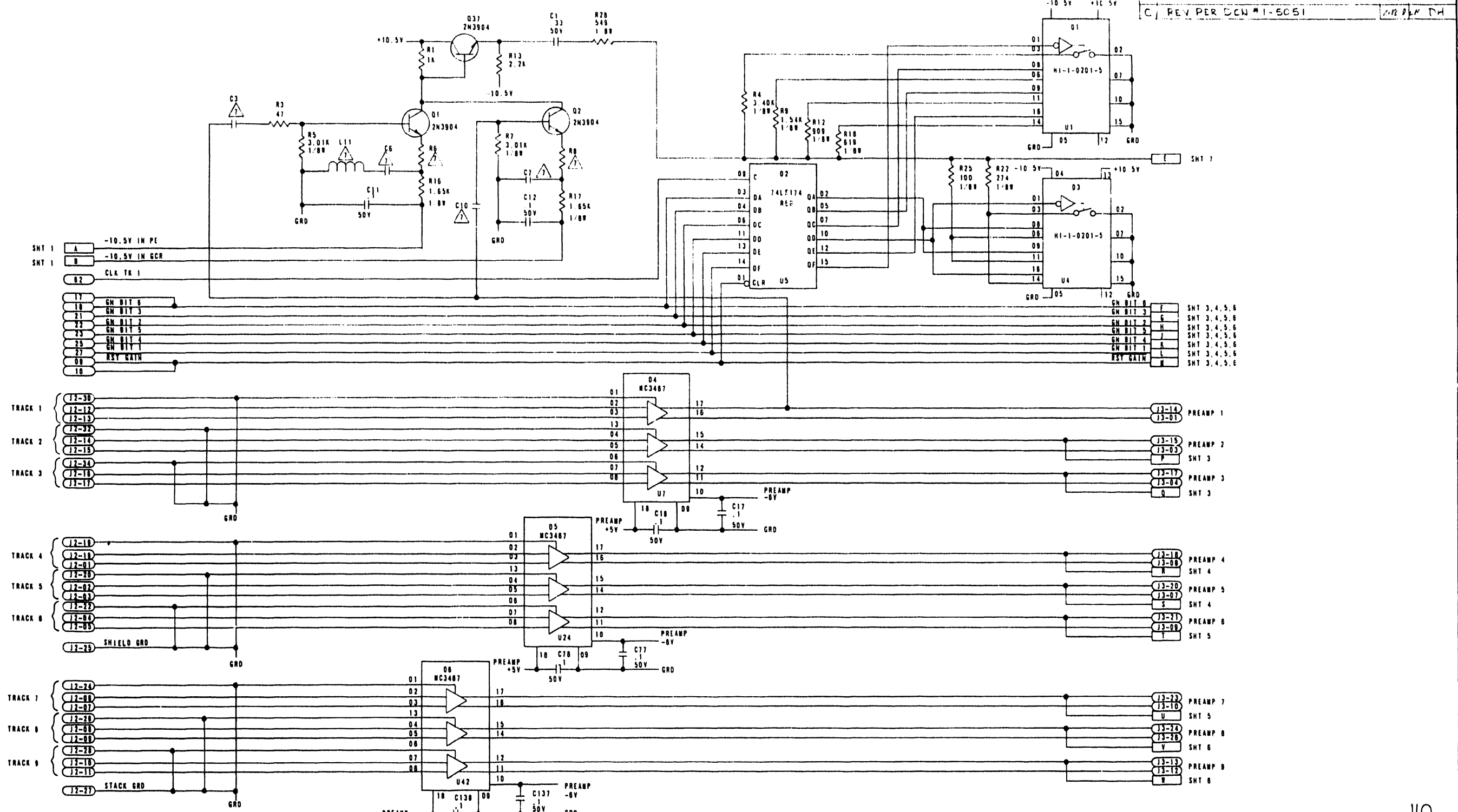

GH BIT 6	GH BIT 5	GH BIT 4	GH BIT 3	RSY GATH
SHT 3, 4, 5, 6	SHT 3, 4, 5, 6	SHT 3, 4, 5, 6	SHT 3, 4, 5, 6	SHT 3, 4, 5, 6

J2-14	J2-15	J2-16	J2-17	J2-18
PREAMP 1	PREAMP 2	PREAMP 3	PREAMP 3	PREAMP 4

J2-19	J2-20	J2-21	J2-22
PREAMP 4	PREAMP 5	PREAMP 6	PREAMP 7

J2-23	J2-24	J2-25	J2-26	J2-27
PREAMP 7	PREAMP 8	PREAMP 8	PREAMP 8	PREAMP 8

TOLERANCES UNLESS OTHERWISE SPECIFIED	DECIMALS XX ± 0 XXX ± 0	ANGULAR ± 30° ± 008 ± 002	HOLE DIAMETER	THREAD CLASS
NO 2				

DRAWN: F. CROSS	DATE: 2/23/80	TELEX TULSA, OKLAHOMA LOGIC DIAGRAM PE-GCR READ	
CHECKED: R. Edwards	DATE: 2/1/80		
APPROVED: D. Henderson	DATE: 2/1/80		
PART NUMBER: 6253	FINISH: USED ON: APPLICATION:	CODE IDENT NO: D	SIZE: 92D72201

J10

SEE SHY	6253
PART NUMBER	USED ON
APPLICATION	

NOTES

DO NOT SCALE THIS PRINT

REVISIONS			
LTN	DESCRIPTION	DATE	APP
C	REV PER DCN #1-5051	2-12-064	DH

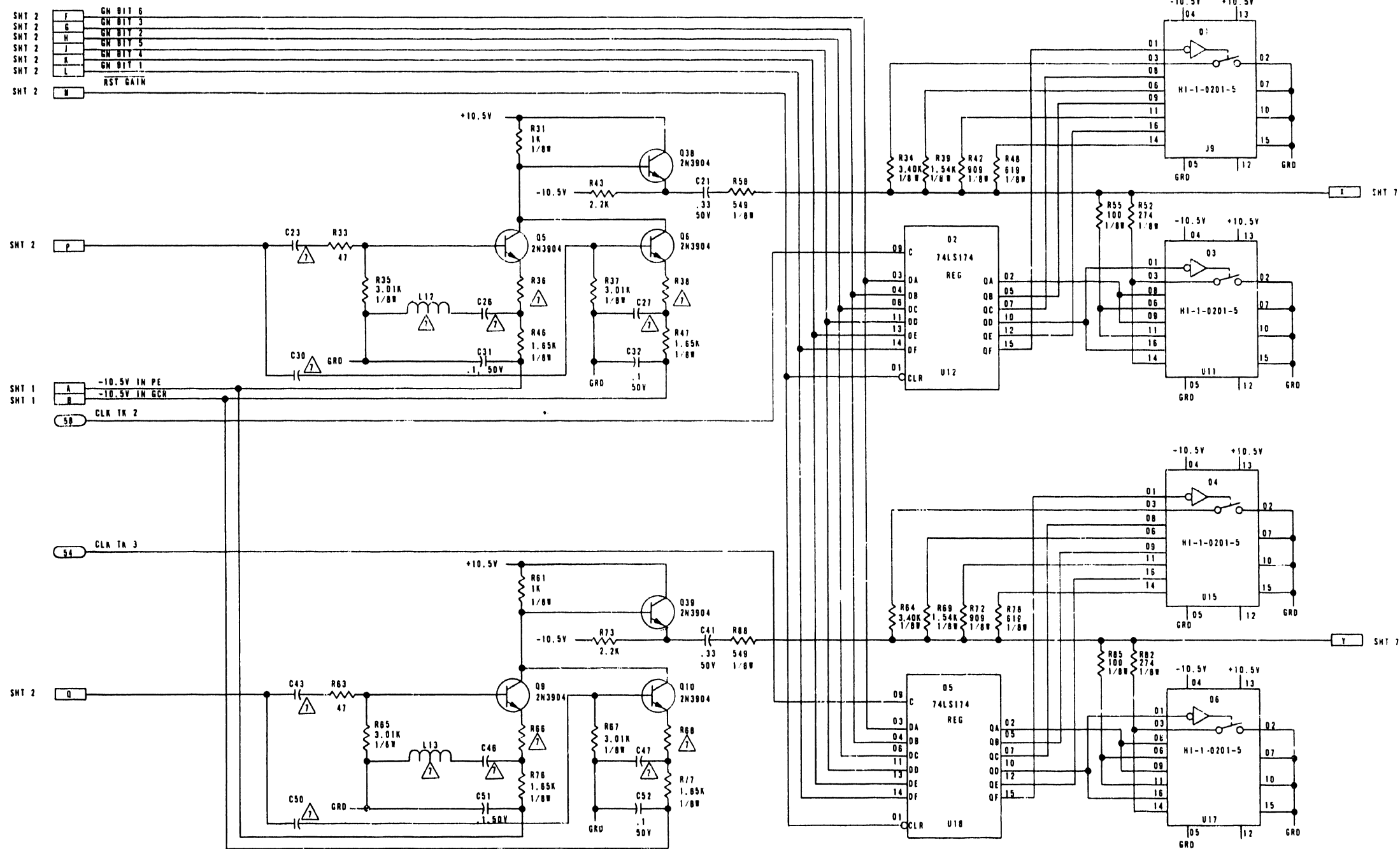

J10

TOLERANCES UNLESS OTHERWISE SPECIFIED		DRAWN	DATE
DECIMALS	ANGULAR	<i>R. Edwards</i>	1/23/80
XX ± 0	± 30		
XAX ± 0			
HOLE DIAMETER	+ .005		
THREAD CLASS	NO 2		

TELEX
TULSA, OKLAHOMA

LOGIC DIAGRAM
PE-GCR READ

SEE SHY	6253
PART NUMBER	NEXT ASSEMBLY USED ON
APPLICATION	FINISH

COOK IDENT NO	SIZE
	D
SCALE	NONE
	92D72201
	SHEET 3 OF 10

NOTES

DO NOT SCALE THIS PRINT

REV	DESCRIPTION	DATE	APP
1	REV PER UCN #1-80E1	12-10-80	AK/DIT

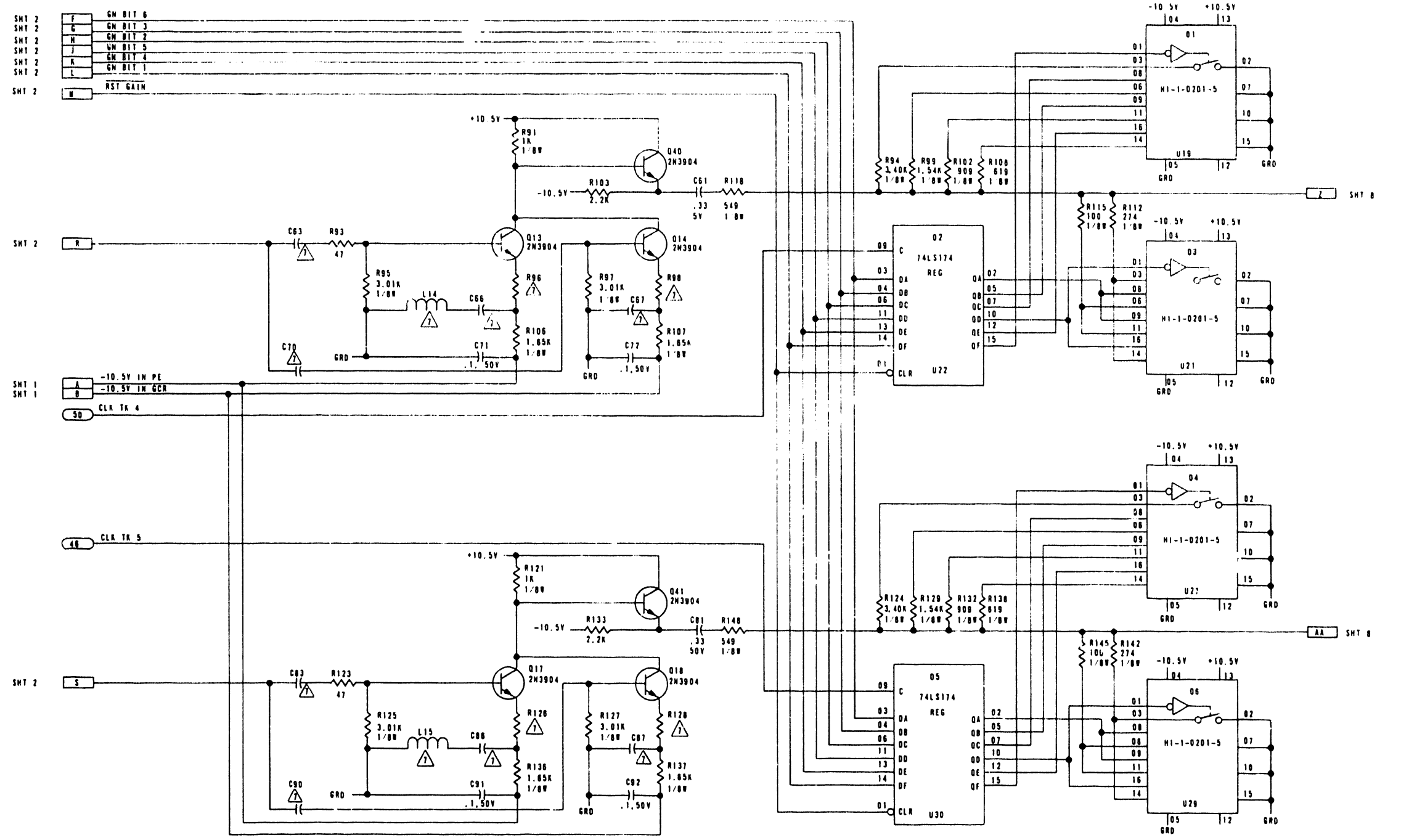

- SHT 2 F GN BIT 6
- SHT 2 G GN BIT 3
- SHT 2 H GN BIT 2
- SHT 2 J GN BIT 5
- SHT 2 K GN BIT 4
- SHT 2 L GN BIT 1
- SHT 2 M RST GAIN

- SHT 2 R
- SHT 1 A -10.5V IN PE
- SHT 1 B -10.5V IN GCR
- 50 CLR TR 4

48 CLR TR 5

- SHT 2 S

J10

TOLERANCES UNLESS OTHERWISE SPECIFIED		DRAWN	DATE	TELEX TULSA OKLAHOMA	
DECIMALS	ANGULAR	<i>L. Edwards</i>	1/13/80	LOGIC DIAGRAM PE-GCR READ	
XX ± 0	: 30	<i>C. Edwards</i>	2/9/80		
HOLE DIAMETER	+ .006	APPROVED	DATE		
THREAD CLASS	- .002	<i>D. Henderson</i>	2/15/80	MATERIAL	
SEE SHY 1		6253		CODE IDENT NO	SIZE
PART NUMBER	NEXT ASSEMBLY	USED ON	FINISH	D	92D72201
APPLICATION				SCALE	NONE
				SHEET 4 OF 10	

NOTES

DO NOT SCALE THIS PRINT

REVISIONS			
LT#	DESCRIPTION	DATE	APP
C	REV PER DCN #1-5051	2-10-60	LK JH

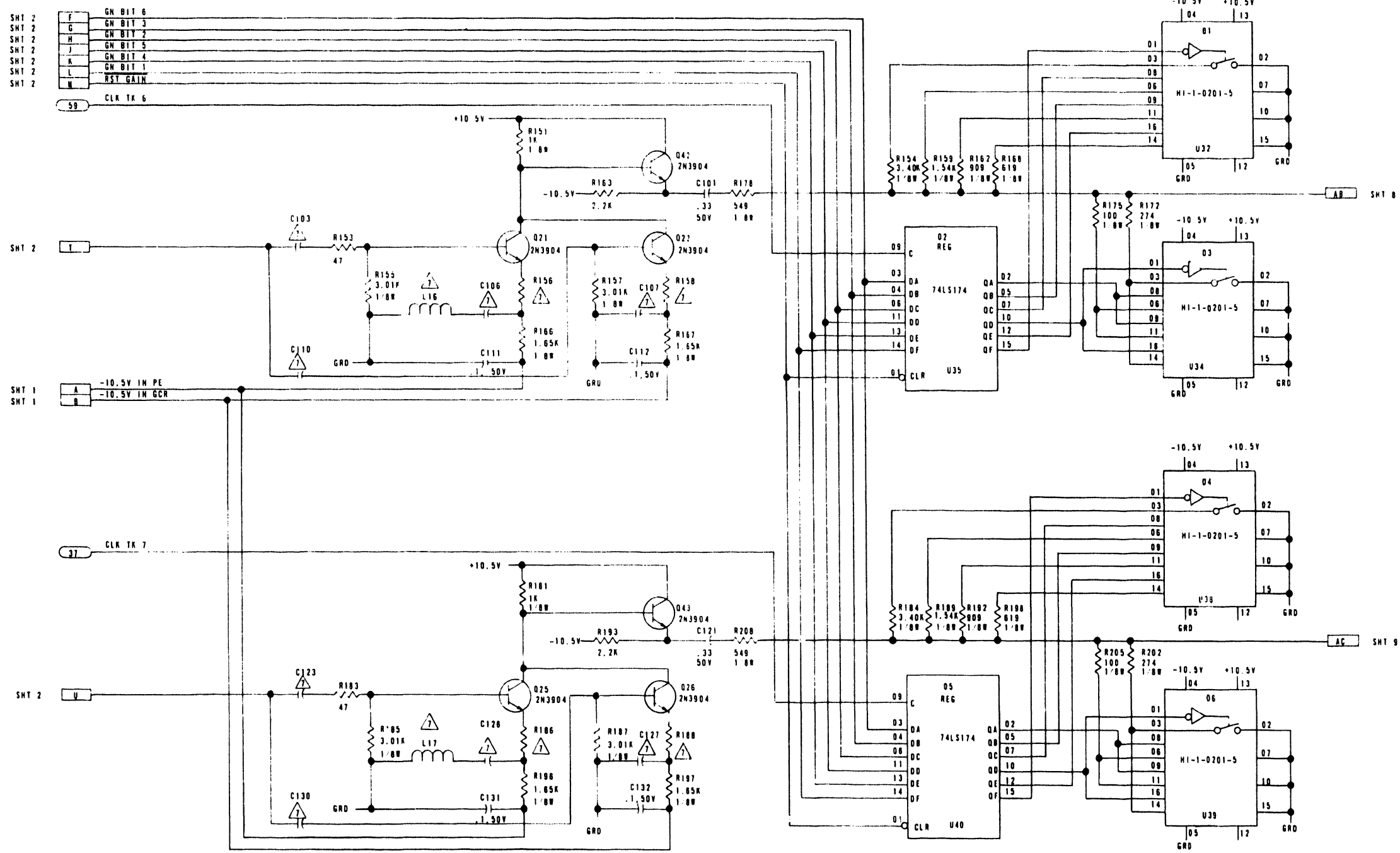

- SHT 2 F GN BIT 6
- SHT 2 G GN BIT 3
- SHT 2 H GN BIT 2
- SHT 2 J GN BIT 5
- SHT 2 K GN BIT 4
- SHT 2 L GN BIT 1
- SHT 2 M RST GAIN

- SHT 1 A -10.5V IN PE
- SHT 1 B -10.5V IN GCR

- SHT 2 U

J10

TOLERANCES UNLESS OTHERWISE SPECIFIED		DRAWN	DATE	TELEX TULSA, OKLAHOMA
DECIMALS	ANGULAR	W. TAYLOR	1-23-80	
XX ± 0	± 30'	CHECKED C. Edwards	2/1/60	LOGIC DIAGRAM PE-GCR READ
XXX ± 0		APPROVED D. HENDERSON	2/5/80	
MOLE DIAMETER	- .002			
THREAD CLASS	NO 2			
MATERIAL				CODE IDENT NO
FINISH				SIZE
SCALE				D
				92D72201
				SHEET 5 OF 10

SEE SHT 1	6253
PART NUMBER	NEXT ASSEMBLY
APPLICATION	USED ON

NOTES

DO NOT SCALE THIS PRINT

REVISONS		DATE	APP
1	REV. PART ON #1 5051	2/18/60	ESJ

- SMT 2 F GM BIT 6
- SMT 2 G GM BIT 3
- SMT 2 H GM BIT 2
- SMT 2 J GM BIT 5
- SMT 2 K GM BIT 4
- SMT 2 L GM BIT 1
- SMT 2 M RST GATE

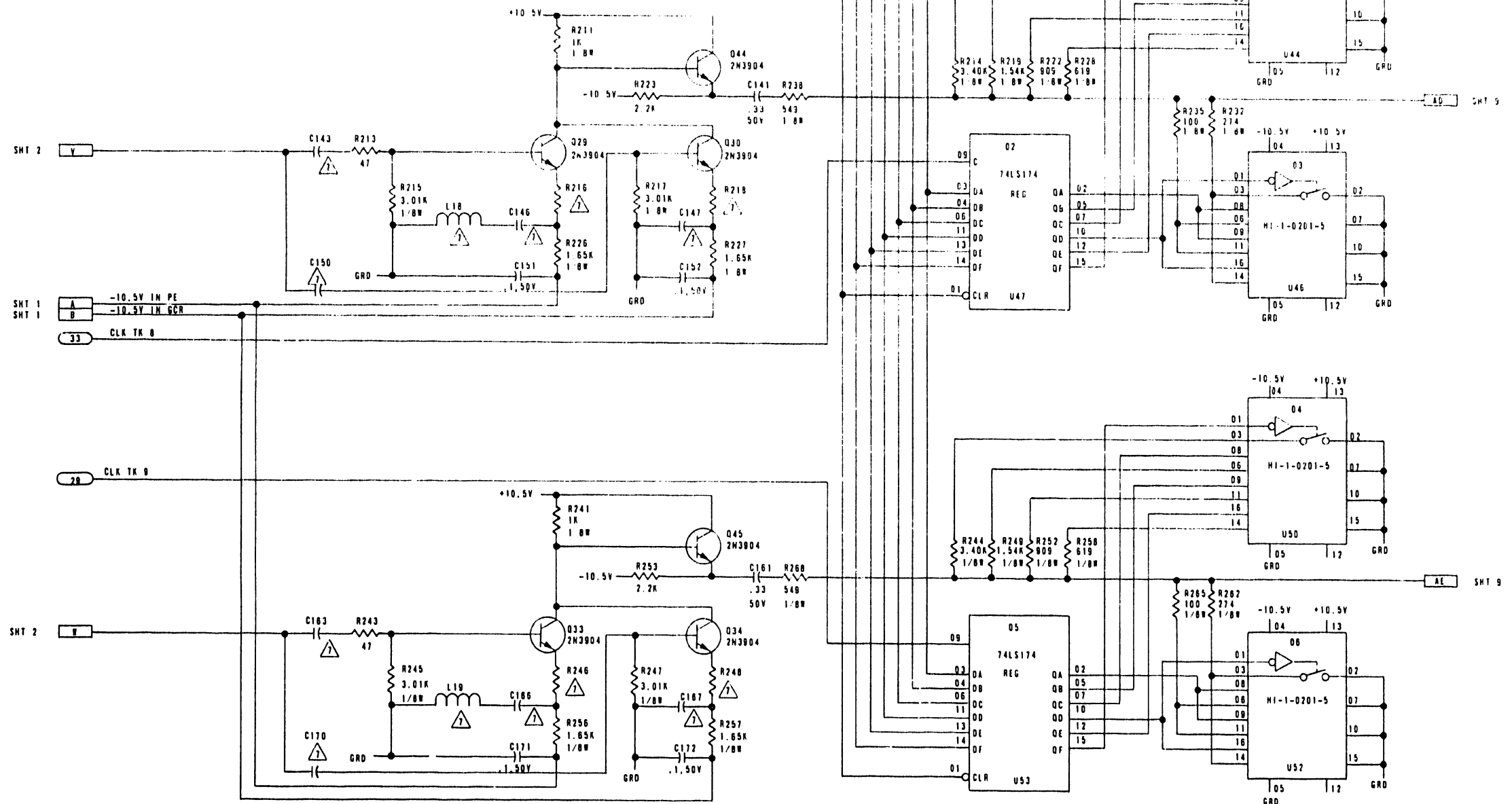

J10

TOLERANCES UNLESS OTHERWISE SPECIFIED		DRAWN	DATE
DECIMALS	ANGULAR	<i>h.w. 1/2</i>	1/24/60
XX ± 0	± 30	CHECKED	DATE
XXX ± 0		<i>C. Edwards</i>	2/1/60
HOLE DIAMETER	+ .008	APPROVED	DATE
THREAD CLASS	- .002	<i>D. ...</i>	2/1/60

TELEX TULSA OKLAHOMA

LOGIC DIAGRAM PE-GCR READ

SEE SMT 1	6253
PART NUMBER	NEXT ASSEMBLY
APPLICATION	USED ON

MATERIAL	CODE / IDENT NO	SIZE
		D
		92D72201
SCALE NONE		SHEET 6 OF 10

NOTES

DO NOT SCALE THIS PRINT

REVISIONS			
LTN	DESCRIPTION	DATE	APP
C	REV PER DCN M1-5051	7/18/60	CR DSH

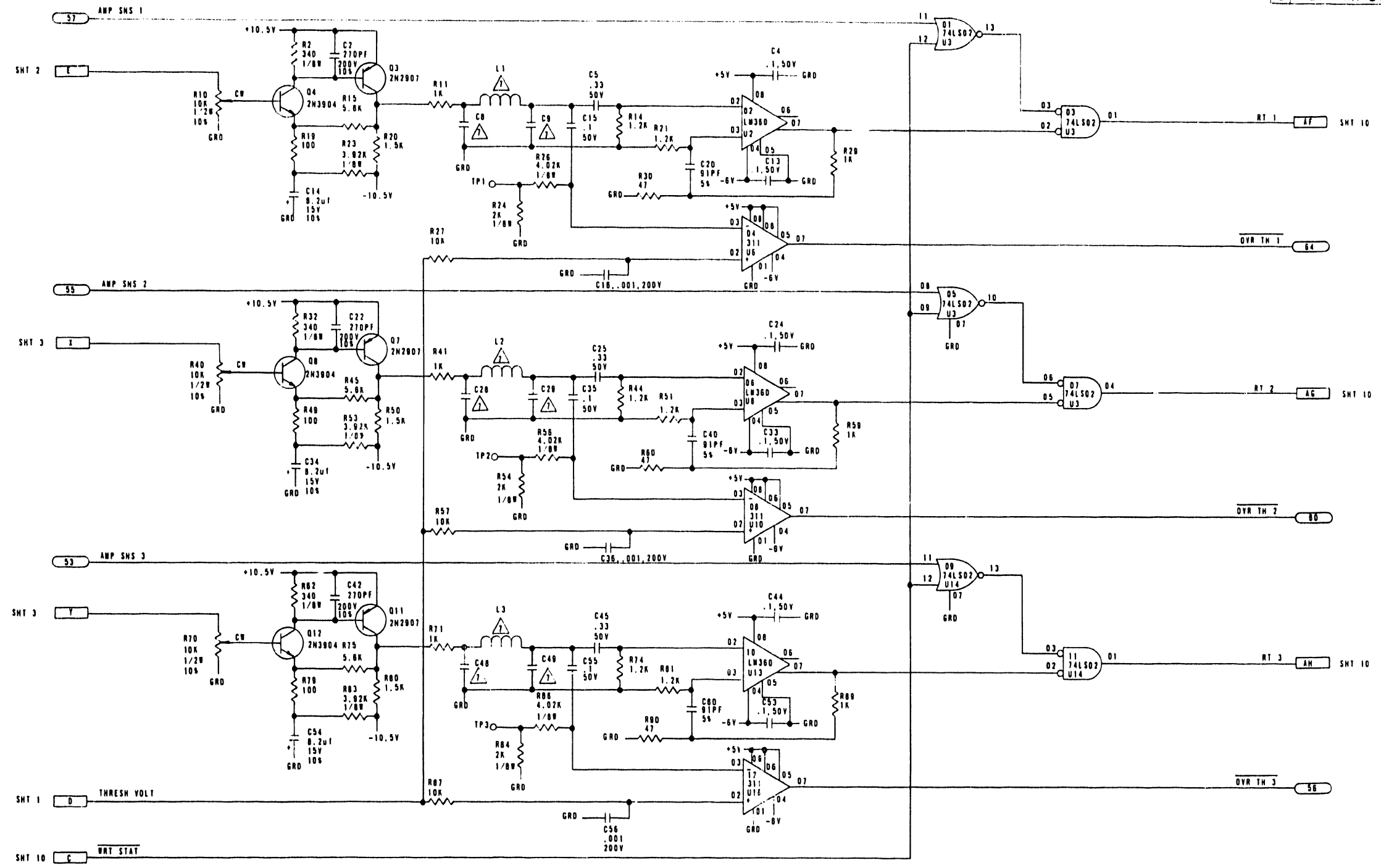

J10

TOLERANCES UNLESS OTHERWISE SPECIFIED		DATE
DECIMALS	ANGULAR	7/24/60
XX ± 0	± 30'	CHECKED
XXX ± 0		<i>A. Edwards</i>
HOLE DIAMETER	+ .005	DATE
THREAD CLASS	- .002	7/15/60
MATERIAL	NO 2	APPROVED
		<i>D. HENDRICKS</i>

TELEX

TULSA OKLAHOMA

LOGIC DIAGRAM
PE-GCR READ

SEE SHY 1	6253
PART NUMBER	USED ON
NEXT ASSEMBLY	
APPLICATION	

CODE IDENT NO	SIZE
	D
MATERIAL	92072201
SCALE	SHEET 7 OF 10

NOTES

DO NOT LEAVE THIS PRINT

REVISIONS

DATE: 1/25/80
DRAWN BY: W. TAYLOR
CHECKED BY: C. Edwards
APPROVED BY: D. H. ...

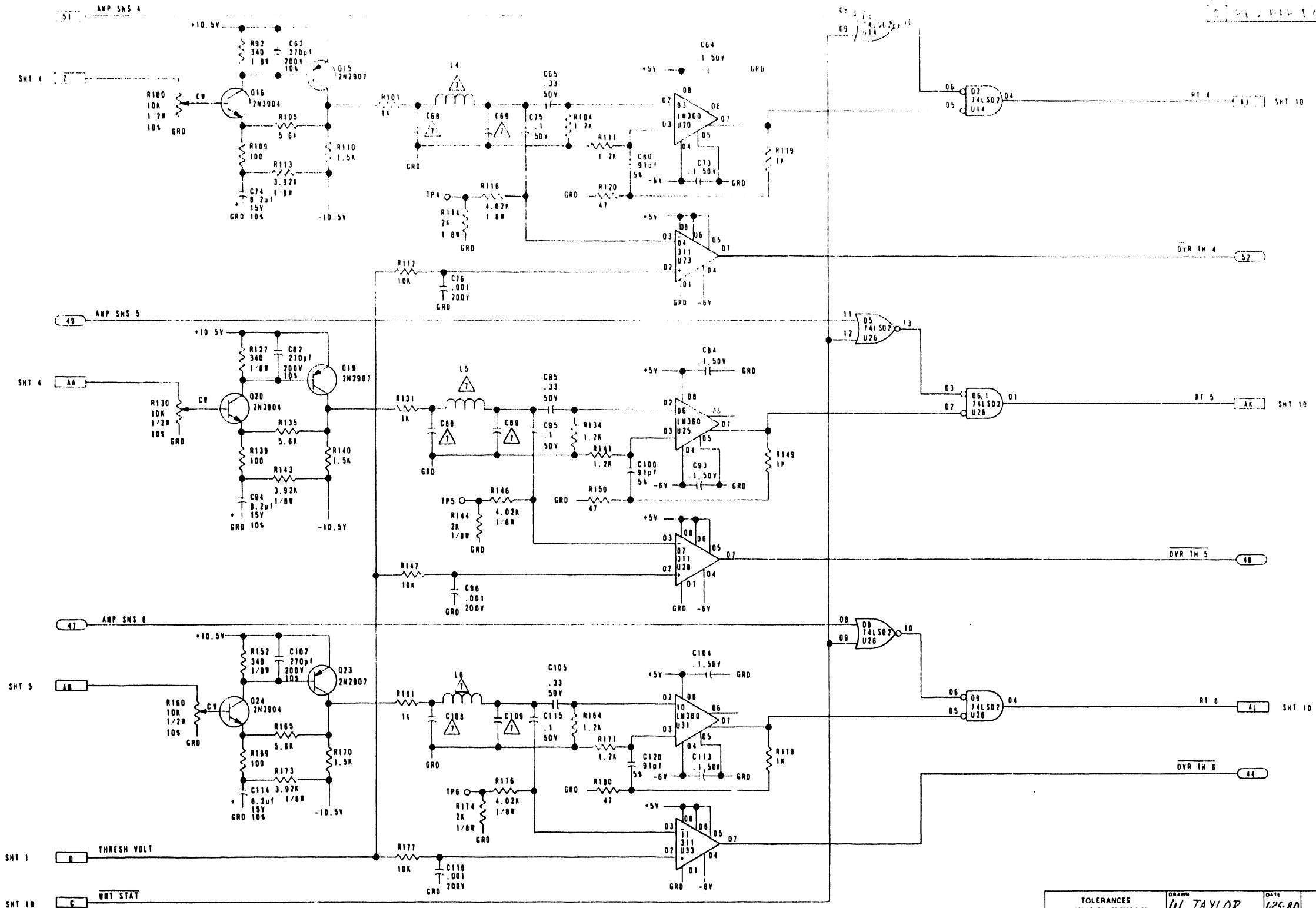

SHT 1 THRESH VOLT

SHT 10 WRT STAT

J10

TOLERANCES UNLESS OTHERWISE SPECIFIED		DRAWN W. TAYLOR	DATE 1/25/80
DECIMALS .30	ANGULAR .30	CHECKED C. Edwards	DATE 2/7/80
HOLE DIAMETER .005	THREAD CLASS NO. 2	APPROVED D. H. ...	DATE 1/25/80

TELEX
TULSA OKLAHOMA

LOGIC DIAGRAM
PE-GCR READ

SEE SHY 1	1/25/80
PART NUMBER	NEXT ASSEMBLY
APPLICATION	UMED ON

CODE IDENT NO	SIZE
D	92D72201
SCALE	SHEET 8 OF 10

NOTES

DO NOT SCALE THIS PRINT

REVISIONS			
REV	DESCRIPTION	DATE	APP
C	REV PER DCN #1-5051	2-18-80	AR 1st

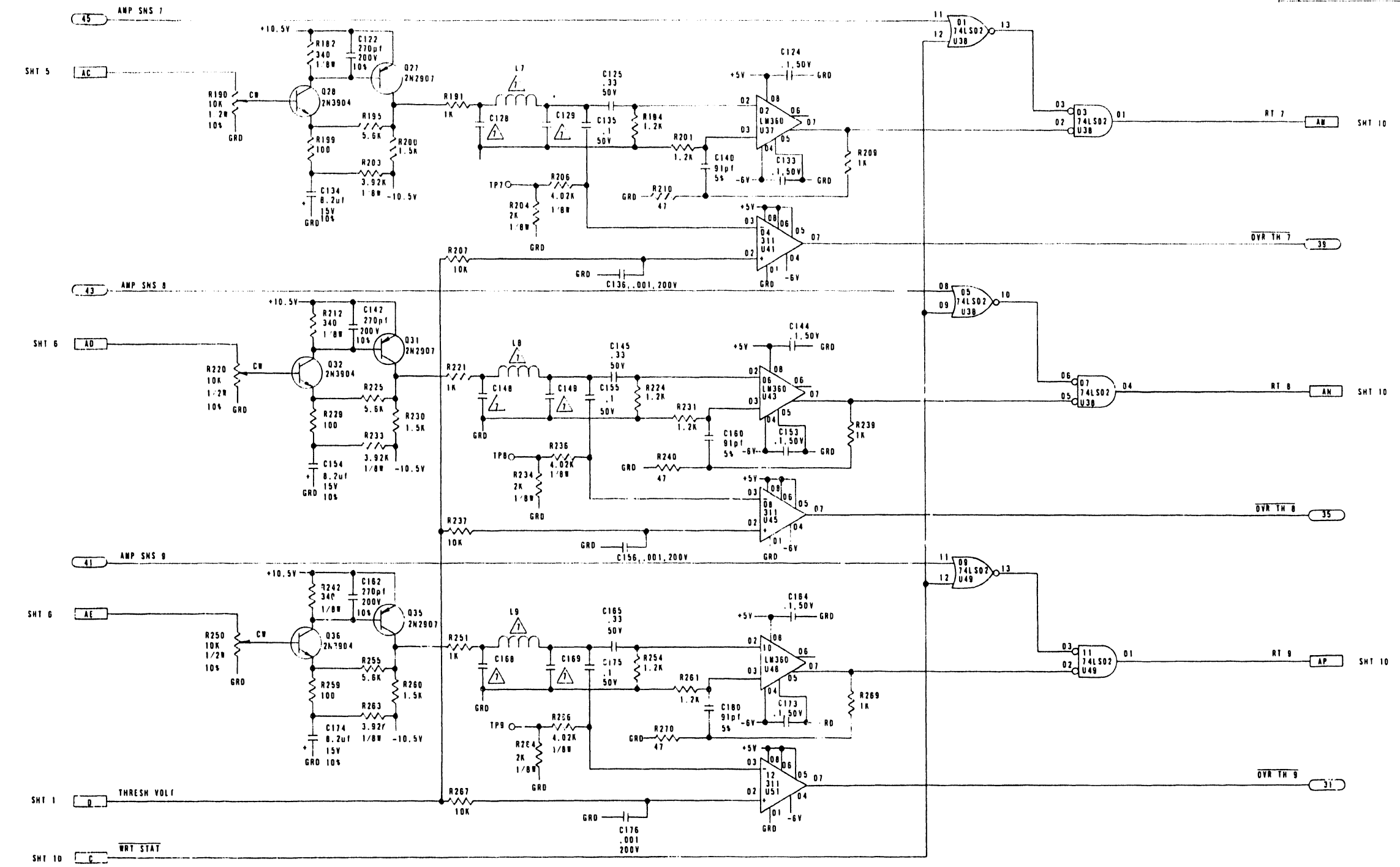

J10

TOLERANCES UNLESS OTHERWISE SPECIFIED		DRAWN F. CROSS	DATE 1/24/80	TELEX TULSA OKLAHOMA
DECIMALS XX ≤ 0	ANGULAR XXX ≤ 0	CHECKED C. Edwards	DATE 2/1/80	
MATERIAL		APPROVED	DATE 2/15/80	LOGIC DIAGRAM PE-GCR READ
PART NUMBER		CODE IDENT NO	SIZE	92D72201
NEXT ASSEMBLY USED ON		SCALE		SHEET 9 OF 10

SEE SHY 1	6253
APPLICATION	

NOTES

DO NOT SCALE THIS PRINT

DATE	1/21/80
DESIGNER	...
CHECKED	...
APPROVED	...
DATE	...

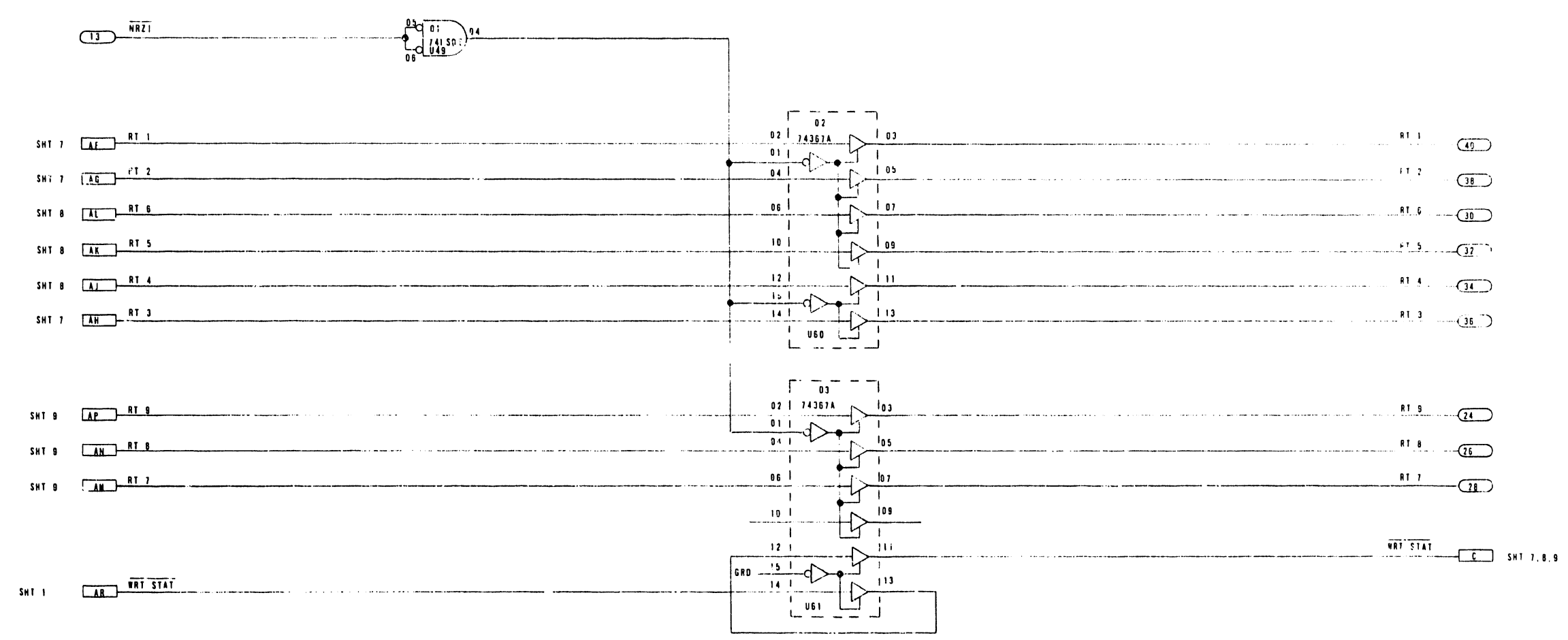

J10

TOLERANCES UNLESS OTHERWISE SPECIFIED		DRAWN	DATE	TELEX TULSA, OKLAHOMA	
DECIMALS	ANGULAR	CHECKED	DATE		
XX ± 0	± 30'	<i>[Signature]</i>	2/3	LOGIC DIAGRAM PE-GCR READ	
XXX ± 0		APPROVED	DATE		
HOLE DIAMETER		MATERIAL		CODE IDENT NO	SIZE
- .002					D
THREAD CLASS		FINISH		SCALE	SHEET
NO 2				NONE	10 OF 10

SEE SHY	6253
PART NUMBER	USED ON
APPLICATION	

- NOTES:
- SEE CHART FOR DASH NUMBER CONVERSION.
 - 14 PIN I.C. - CONNECT PIN 07 TO GND & PIN 14 TO +5VDC.
 - 16 PIN I.C. - CONNECT PIN 08 TO GND & PIN 16 TO +5VDC.
 - RESISTANCE VALUES ARE IN OHMS, 1/4W, 5% UNLESS SPECIFIED.
 - CAPACITANCE VALUES ARE IN MICROFARADS, 100V UNLESS SPECIFIED.
 - ALL DIODES TYPE 1N9711 UNLESS SPECIFIED.

DO NOT SCALE THIS PRINT

REVISIONS			
LTN	DESCRIPTION	DATE	APP
	DESIGN PER DCN # 1553	7/15/80	DH
	REVISED PER DCN # 15507-2	8/4/80	NH

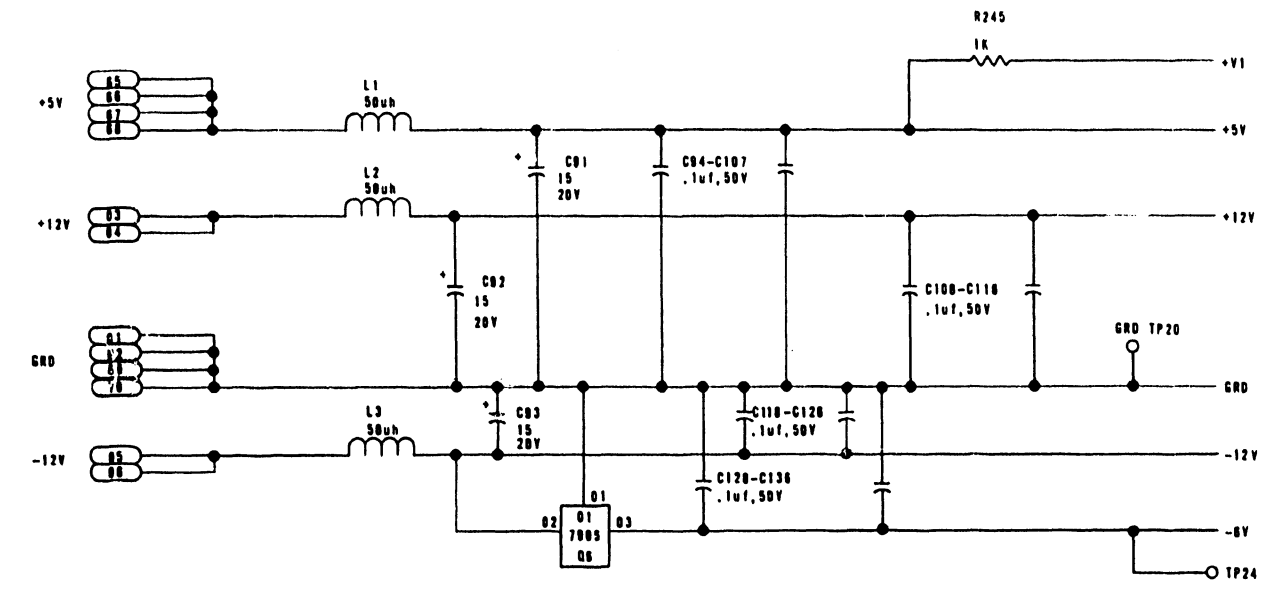

SPARES LIST		
COMPONENT	REF DESIG	SPARES
7400	U50	05, 06
96L02	U54	11, 12, 13, 14, 15, 00, 10

REF DESIGNATION MODEL SPEED	R3, 4, 20, 20, 53, 54, 70, 70, 103, 104, 120, 120, 153, 154, 170, 170, 203, 204	C5, 15, 25, 35, 45, 55, 65, 75, 85	C6, 16, 20, 30, 40, 50, 60, 70, 80	C7, 17, 27, 37, 47, 57, 67, 77, 87	C8, 18, 20, 30, 40, 50, 60, 70, 80	C9, 19, 20, 30, 40, 50, 60, 70, 80	S1	JUMPERS	C1, 2, 11, 12, 21, 22, 31, 32, 41, 42, 51, 52, 61, 62, 71, 72, 81, 82	R235	R236	R237	R240
-01 50 IPS	34.0K	270pf	80pf	270pf	800pf	270pf		J1-J8, J11	80pf	1.02K	6.40K	-	9.31K
-02 75 IPS	64.0K	100pf	47pf	150pf	470pf	150pf		J1-J8, J11	22pf	1.02K	6.40K	-	9.31K
-03													
-04 125 IPS	40.2K	100pf	27pf	100pf	270pf	100pf		J1-J8, J11	22pf	1.02K	6.40K	-	9.31K
-05 50 IPS	34.0K	270pf	80pf	270pf	800pf	270pf	X	J1-J8	80pf	1K	10.2K	6.40K	100K
-06 75 IPS	64.0K	100pf	47pf	150pf	470pf	150pf	X	J1-J8	22pf	1K	10.2K	6.40K	100K
-08 125 IPS	40.2K	100pf	27pf	100pf	270pf	100pf	X	J1-J8	22pf	1K	10.2K	6.40K	100K

REFERENCE DESIGNATION	
LAST USED	NOT USED
C137	C117, 127
CR101	CR6, 7, 10, 16, 17, 20, 26, 27, 30, 30, 37, 40, 40, 47, 50, 50, 57, 60, 60, 67, 70, 70, 77, 80, 80, 87, 90-100
J11	-
L3	-
Q8	-
R240	R 240, 241
TP25	TP10
U50	U7, 10, 31, 43, 55

891C12202-06	6253
891C12202-05	6253
891C12202-05	6253
891C12202-04	6253
891C12202-02	6253
891C12202-01	6253
PART NUMBER	USE IT ASSEMBLY
USED ON	FRSH
APPLICATION	

TOLERANCES UNLESS OTHERWISE SPECIFIED		DATE
DECIMALS	ANGULAR	1-25-80
.XX ± 0	± 30'	
.XXX ± 0		
HOLE DIAMETER	+ .005	DATE
THREAD CLASS	- .002	3/13/80
		APPROVED
		D. HENDERSON 7/3/80
		DATE
		7/3/80

REVISION	H	D	C	C	C	C	C	C	C	J9A
SHEETS	1	2	3	4	5	6	7			

TELEX
TULSA, OKLAHOMA

LOGIC DIAGRAM
NRZI READ ELECTRONICS

CODE IDENT NO: **D** 92D72202

SHEET 1 OF 7

NOTES:

DO NOT SCALE THIS PRINT

REVISIONS		DATE	APP
1	REWORKED PER D.W. #1 5503	7/31/80	DH

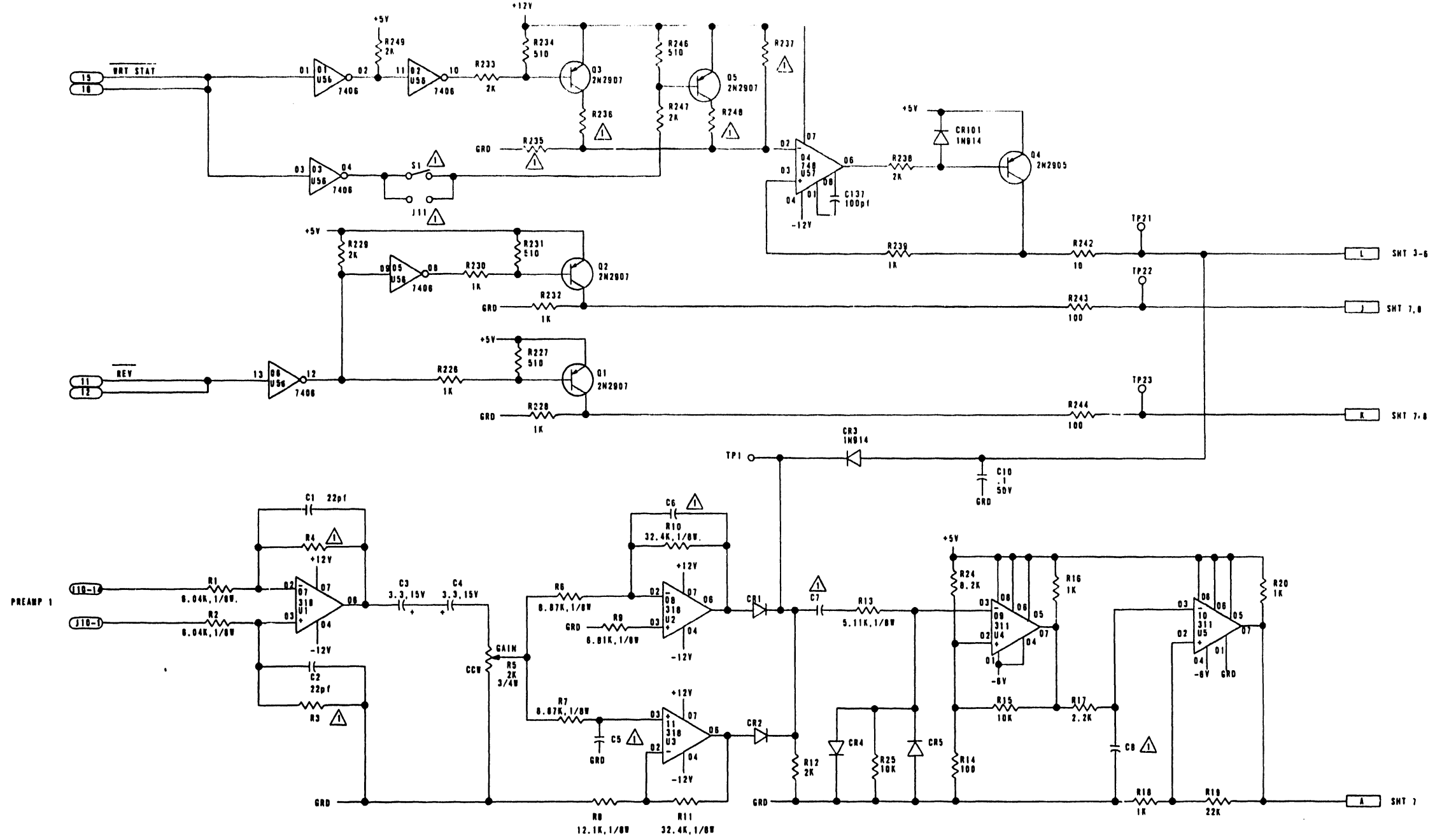

J9A

TOLERANCES UNLESS OTHERWISE SPECIFIED		DRAWN	DATE	TELEX TULSA, OKLAHOMA
DECIMALS	ANGULAR	<i>W. TAYLOR</i>	<i>1-28-80</i>	
.XX ± 0	± 30'	CHECKED	DATE	LOGIC DIAGRAM NRZI READ ELECTRONICS
.XXX ± 0		<i>22-3-5-0</i>		
HOLE DIAMETER	+ .006	APPROVED	DATE	
THREAD CLASS	NO. 2	<i>D. HENDERSON</i>	<i>7/31/80</i>	
MATERIAL				CODE IDENT NO.
				D 92D72202
				SCALE
				SHEET 2 OF 7

SEE SH. 1	6253
PART NUMBER	NEXT ASSEMBLY USED ON
APPLICATION	

NOTES

DO NOT SCALE THIS PRINT

REVISIONS			
LTR	DESCRIPTION	DATE	APP
C	PELLAHIN PCB DCN # 1-5503	2/3/81	DH

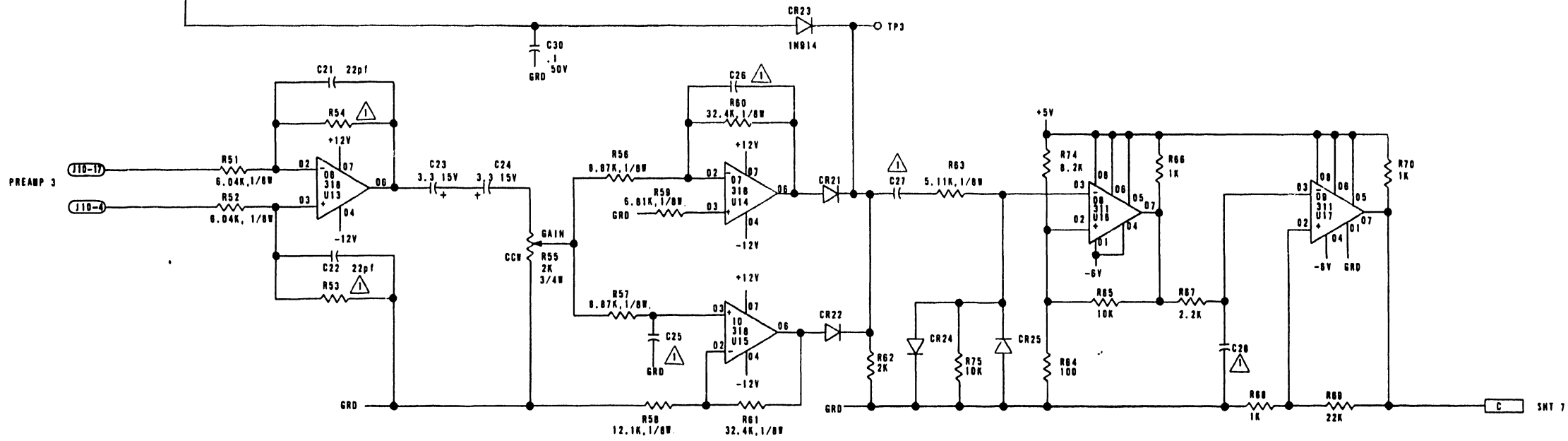
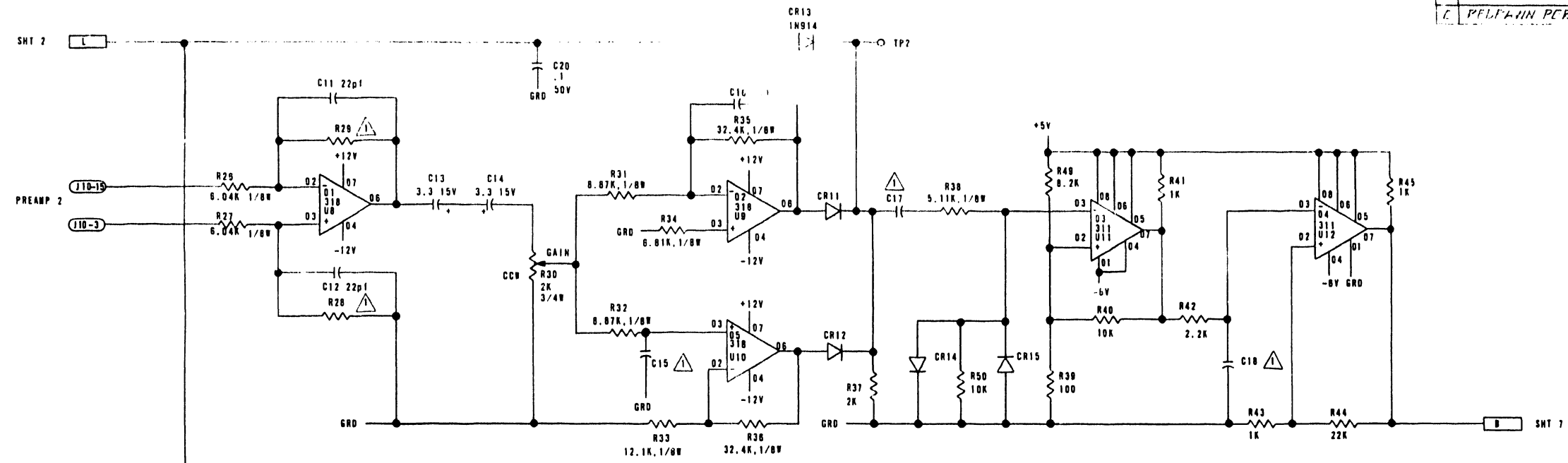

J9A

TOLERANCES UNLESS OTHERWISE SPECIFIED	DRAWN W. TAYLOR	DATE 1-28-80	TELEX TULSA, OKLAHOMA
DECIMALS .XX ± .0	CHECKED CR 3.5.0	DATE	
ANGULAR .XXX ± .0	APPROVED D. HENDERSON	DATE 2/3/81	NRZI READ ELECTRONICS
HOLE DIAMETER .006			
THREAD CLASS NO. 2			
MATERIAL			CODE IDENT NO
			SIZE
			D
			92D72202
			SHEET 3 OF 7

SEE SHT. 1	6253
PART NUMBER	USED ON
NEXT ASSEMBLY	
APPLICATION	

NOTES:

DO NOT SCALE THIS PRINT

REVISIONS		DATE	APP
111	DESCRIPTION		
	REWORK FOR D.W. #10003	2/3/81	DH

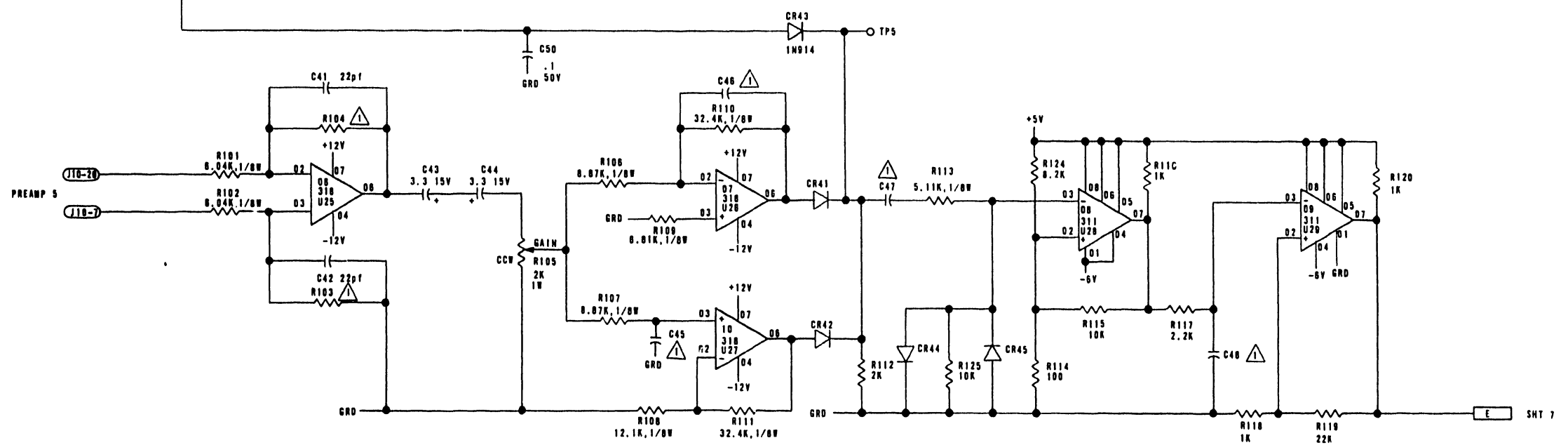
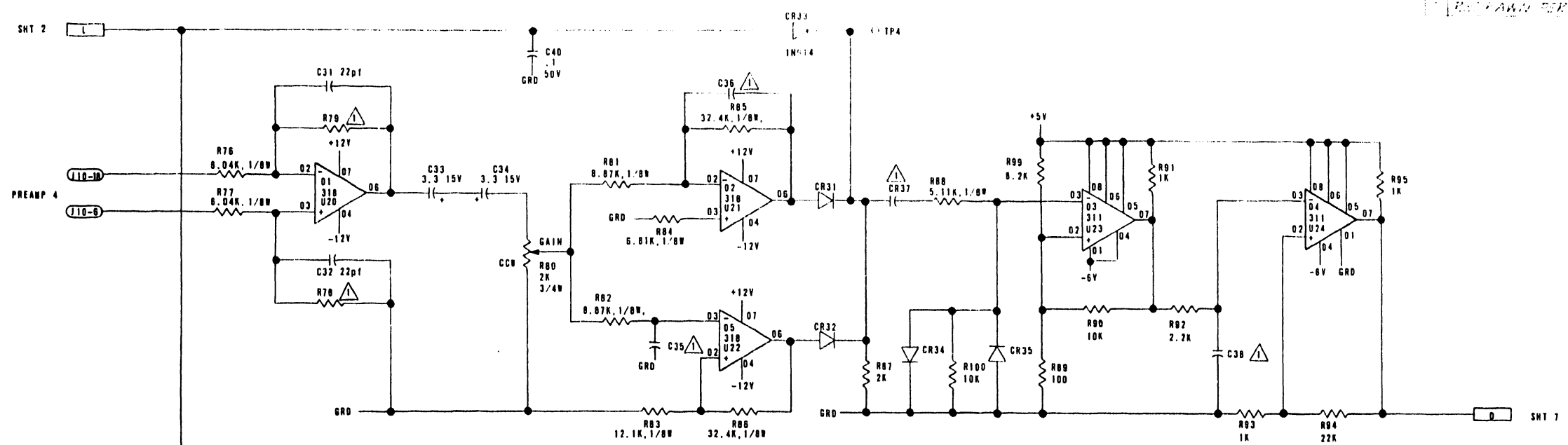

J9A

TOLERANCES UNLESS OTHERWISE SPECIFIED		DRAWN	DATE	TELEX TULSA, OKLAHOMA
DECIMALS	ANGULAR	<i>W. TAYLOR</i>	1-28-80	
.XX ± 0	± 30'	CHECKED	DATE	LOGIC DIAGRAM NRZI READ ELECTRONICS
.XXX ± 0		<i>R 5.5.0</i>		
HOLE DIAMETER	± .005	APPROVED	DATE	CODE IDENT NO
THREAD CLASS	NO. 2	<i>D. HENDERSON</i>	2/3/81	
MATERIAL				SIZE
				D
				92D72202
				SHEET 4 OF 7

SEE SHT 1	6253
PART NUMBER	NO. XT ASSEMBLY
	USED ON
APPLICATION	

NOTES:

DO NOT SCALE THIS PRINT

REVISIONS			
LTN	DESCRIPTION	DATE	APP
1	PEDPAWN PER DLN # 15503	7/3/81	DM CES

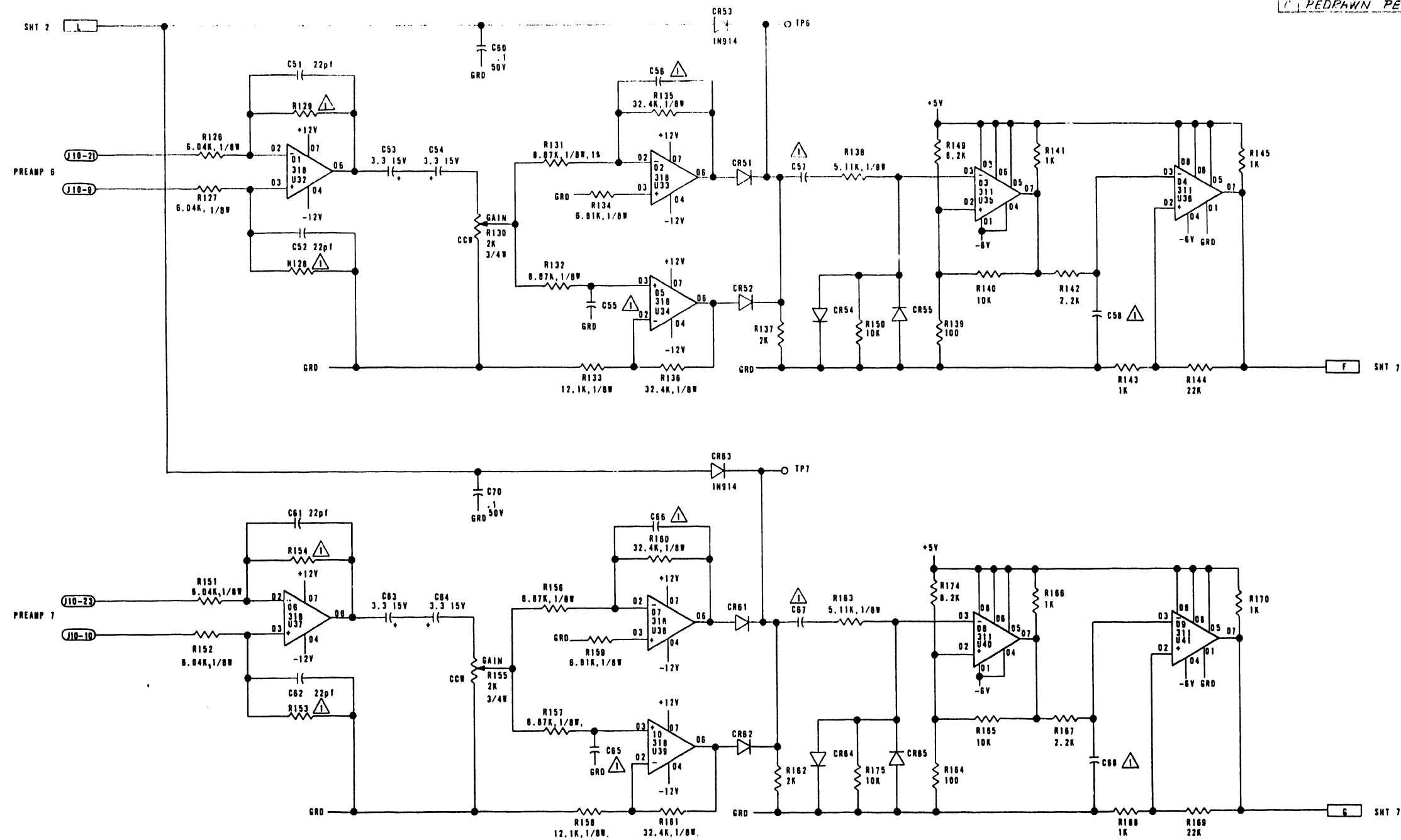

J9A

TOLERANCES UNLESS OTHERWISE SPECIFIED		DRAWN	DATE	TELEX TULSA, OKLAHOMA
DECIMALS	ANGULAR	W. TAYLOR	1/29/80	
.XX ± 0	± 30'	CHECKED	2/2 3:50	LOGIC DIAGRAM NRZI READ ELECTRONICS
.XXX ± 0		APPROVED	2/3/81	
HOLE DIAMETER	+ .006			CODE IDENT NO. SIZE
THREAD CLASS	- .002			
MATERIAL		APPLICATION		SCALE
SEE SHY 1		6253		SHEET 5 OF 7

NOTES:

DO NOT SCALE THIS PRINT

REVISIONS			
LTN	DESCRIPTION	DATE	APP
1	REVISION	2/3/81	DH

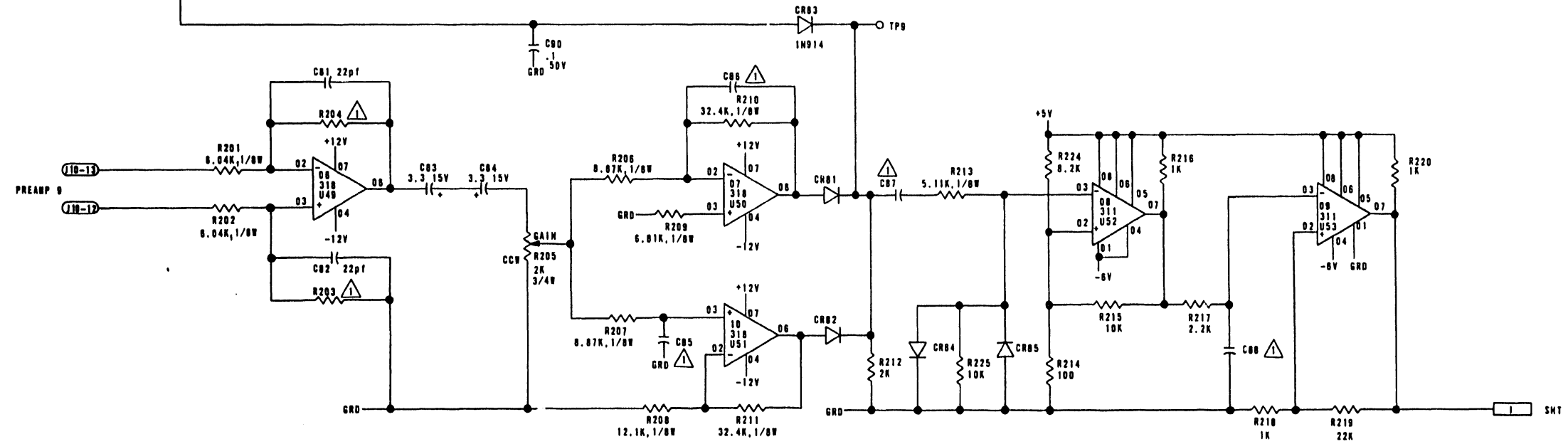
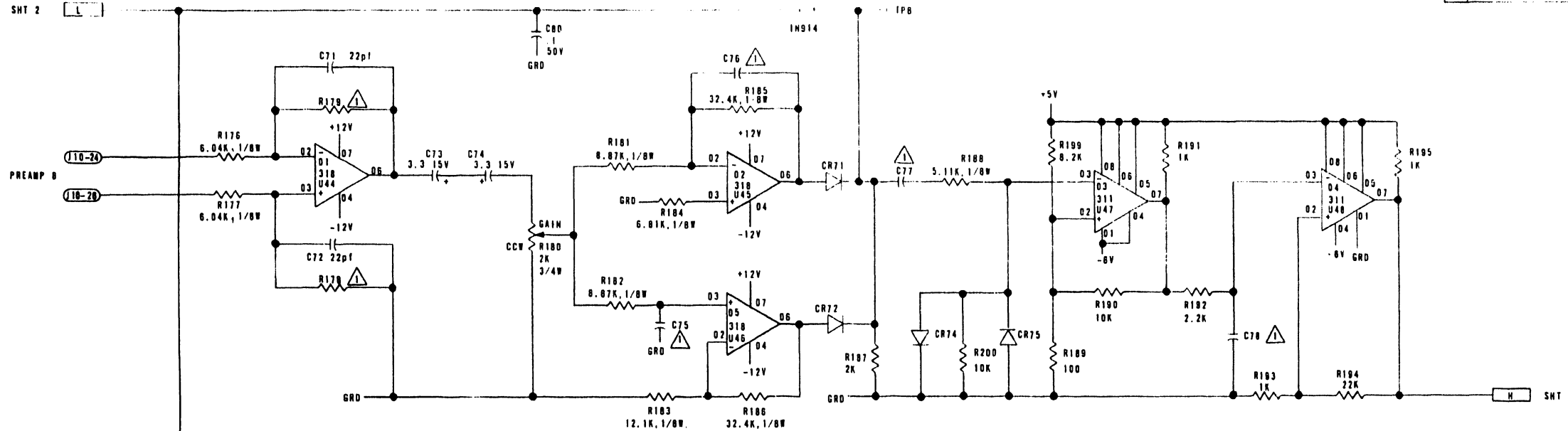

J9A

TOLERANCES UNLESS OTHERWISE SPECIFIED		DRAWN W. TAYLOR	DATE 1/29/80	TELEX TULSA, OKLAHOMA
DECIMALS .XX ± .0	ANGULAR ± 30'	CHECKED L.L. 3-5-80	DATE	
HOLE DIAMETER ± .005		APPROVED D. HENDERSON	DATE 2/3/81	
THREAD CLASS NO. 2				
MATERIAL				CODE IDENT NO. D
FINISH				SIZE 92D72202
APPLICATION				SCALE

SEE SHT. 1	4253
PART NUMBER	NEXT ASSEMBLY
USED ON	

NOTES:

DO NOT SCALE THIS PRINT

REVISIONS			
LTN	DESCRIPTION	DATE	APP
C	REDRAWN PER DWN # 1-5505	2/10/60	DT

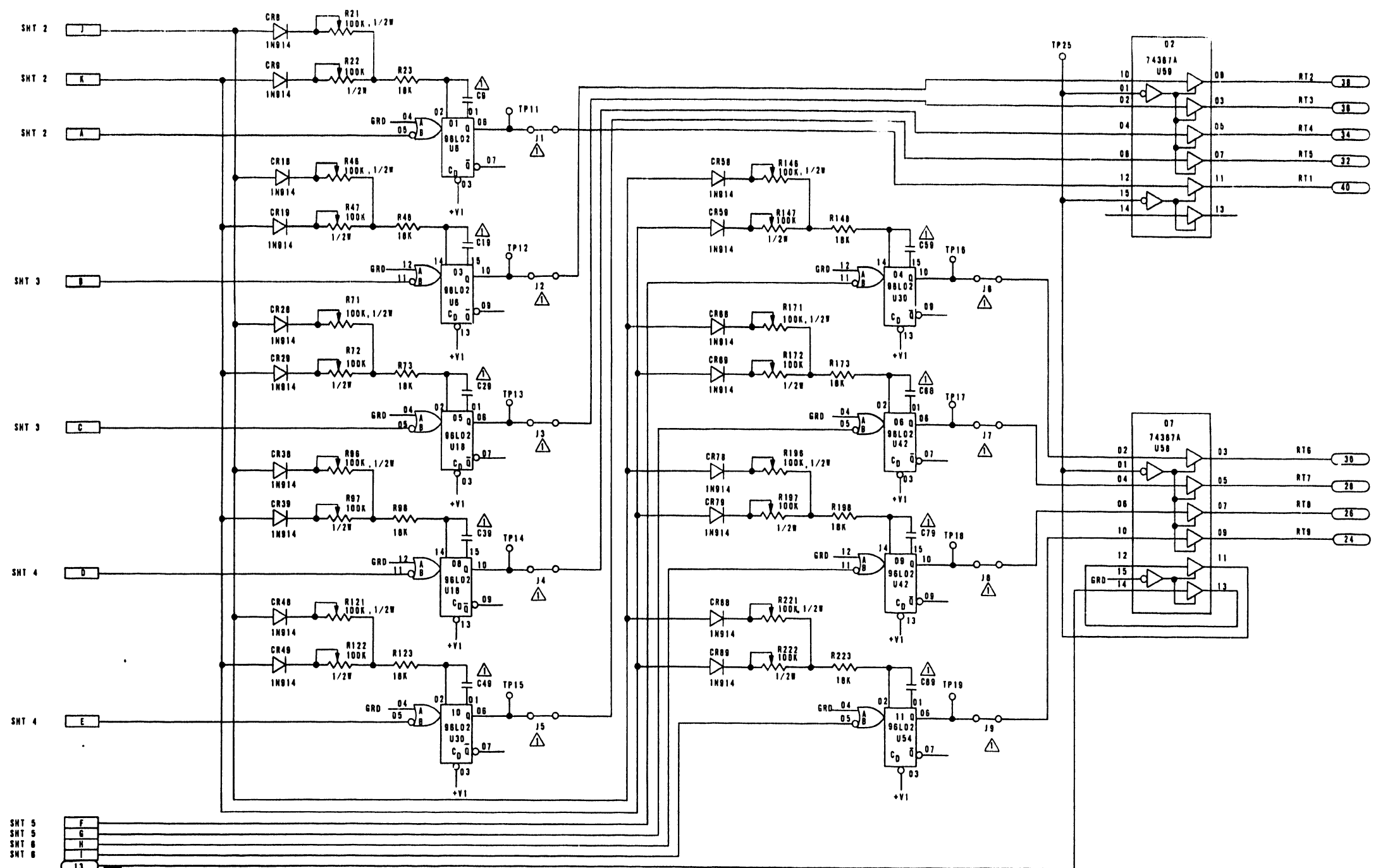

J9A

TOLERANCES UNLESS OTHERWISE SPECIFIED		DRAWN F. CROSS	DATE 1/29/60	TELEX TULSA, OKLAHOMA
DECIMALS .XX ± 0 .XXX ± 0	ANGLE ± 30'	CHECKED DE	DATE 3/15/60	
HOLE DIAMETER + .005 - .002	THREAD CLASS NO. 2	APPROVED D. HENDERSON	DATE 2/23/61	LOGIC DIAGRAM NRZI READ ELECTRONICS
MATERIAL				CODE IDENT NO D
SEE SHT. 1	6253			SIZE 92D72202
PART NUMBER	NEXT ASSEMBLY	USED ON	FINISH	SCALE
APPLICATION				SHEET 7 OF 7

NOTES: UNLESS OTHERWISE SPECIFIED:
 1. 14 PIN I.C. - CONNECT PIN 07 TO GRD
 -CONNECT PIN 14 TO +5VDC
 2. 16 PIN I.C. - CONNECT PIN 08 TO GRD
 -CONNECT PIN 16 TO +5VDC
 3. RESISTANCE VALUES ARE IN OHMS, 1K, 5K, 10K, 100K, 1M, 5M, 10M, 50M, 100M, 500M, 1G.
 4. ALL I.C.'S ARE 74...
 ⚠ AT 23 GRD PINS 01, 02, 03, 04, 10, 11, 12, 13
 SIMPLIFIED SYMBS JL 76 Y
 ⚠ TP1 NOT USED ON -19.

REVISIONS		DATE	APP.
1	REVISION #1	10/17/75	WJ
2			
3			

TAG IN	A	SHT. 6
TAG OUT	B	SHT. 5
U20	C	SHT. 3

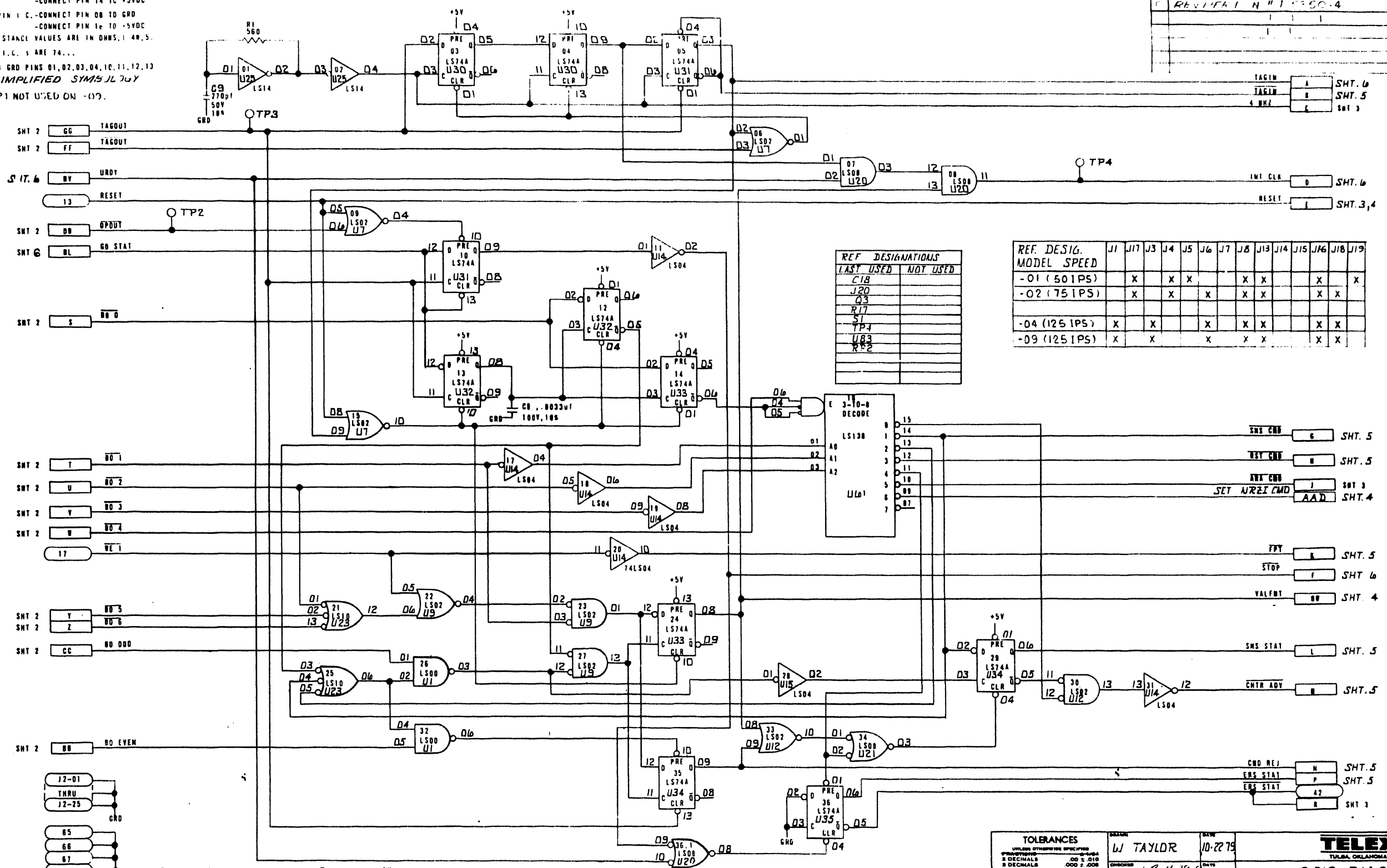

REF DESIGNATIONS	
LAST USED	NOT USED
C18	
J20	
R17	
S1	
TP1	
U83	
R42	

REF. DESIG.	J1	J17	J3	J4	J5	J6	J7	J8	J13	J14	J15	J16	J18	J19
MODEL SPEED														
-01 (50 IPS)	X	X	X	X	X	X	X	X	X	X	X	X	X	X
-02 (75 IPS)	X	X	X	X	X	X	X	X	X	X	X	X	X	X
-04 (125 IPS)	X	X	X	X	X	X	X	X	X	X	X	X	X	X
-09 (125 IPS)	X	X	X	X	X	X	X	X	X	X	X	X	X	X

- SHT 2 GG TAGOUT
- SHT 2 FF TAGOUT
- SHT 6 BY URDY
- 13 RESET
- SHT 2 DD 07DUT
- SHT 6 BL GO STAT
- SHT 2 S 00 0
- SHT 2 T 00 1
- SHT 2 U 00 2
- SHT 2 Y 00 3
- SHT 2 W 00 4
- 17 WE 1
- SHT 2 Y 00 3
- SHT 2 Z 00 6
- SHT 2 CC 00 000
- SHT 2 00 00 EVEN
- J2-01 THRU J2-25
- 01
- 02
- 05
- 06
- 07
- 08
- 09
- 10

- SHT 5 SWS CMD 6
- SHT 5 TEST CMD 8
- SHT 3 SWA CMD 7
- SHT 4 SET URZE CMD AAD
- SHT 5 FFY 6
- SHT 6 STOP 7
- SHT 4 VALFRT 00
- SHT 5 SWS STAT L
- SHT 5 CNTR ADV 8
- SHT 5 CMD REJ H
- SHT 5 ERS STAT P
- SHT 3 ERS STAT 42

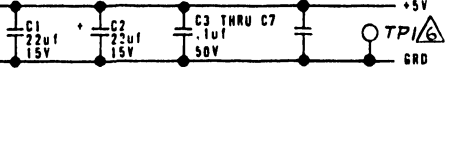

COMPONENT	REF. DESIG.	SPARES
74LS00	U2	04, 05, 06
74LS08	U22	12, 13, 11
74LS10	U55	09, 10, 11, 08
74LS04	U16, U19	(03, 08) (09, 09)
74LS74A	U43	01 THRU 06
74LS02	U8, U13	(11, 12, 13) (04, 05, 06) (08, 09, 10)
74LS36B	U47	14, 13, 15

DATE	DESIGN	APP.
10-22-75	WJ TAYLOR	

TOLERANCES	
UNLESS OTHERWISE SPECIFIED:	
FRACTIONS	100 ± 0.04
DECIMALS	00 ± 0.10
3 DECIMALS	000 ± 0.005
ANGULAR	± 30'
THREAD CLASS	NO. 2
HOLE DIAMETER	+ 0.005
DECIMAL	- 0.005
FRACTIONS	± 0.005

TELEX
TULSA, OKLAHOMA

LOGIC DIAGRAM
TELEX INTERFACE

92D72203

REVISION J B B D D A
SHEETS 1 2 3 4 5 6

NOTES:

DO NOT SCALE THIS PRINT

REV	DESCRIPTION	DATE	APP
A	REL PER EPO 480-3	12-11-79	WJL
B	REV. PER DCN # 1-4095	1-2-80	DH

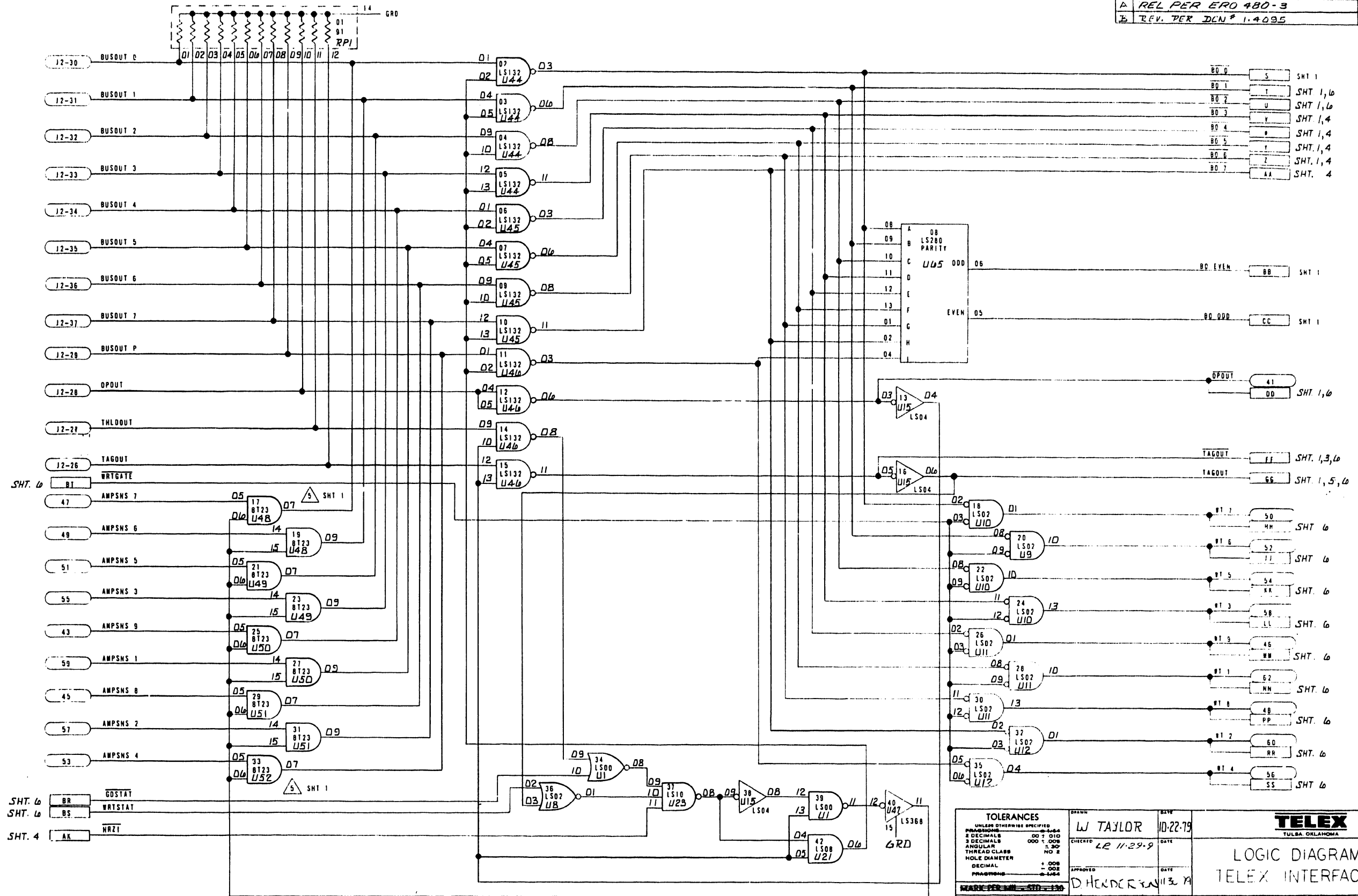

J7

TOLERANCES UNLESS OTHERWISE SPECIFIED FRACTIONS: ±0.005 DECIMALS: ±0.010 ANGULAR: ±0.005 HOLE DIAMETER: +0.005 DECIMAL: ±0.005 FRACTIONS: ±0.005		DRAWN: W TAYLOR CHECKED: LE 11-29-79 DATE: 10-22-79	TELEX TULSA, OKLAHOMA
APPLICATION: SEE SHT. 4, 6253		APPROVED: D HENDERSON DATE: 11-3-79	LOGIC DIAGRAM TELEX INTERFACE
MATERIAL:		CODE IDENT NO: D	PART NO: 92D72203

NOTES

DO NOT SCALE THIS PRINT

REVISIONS

REV	DESCRIPTION	DATE	APP
A	REL PER ERO# 480-3	11-29-79	LR
B	REV PER DCN # 1.4035	11-29-79	DA

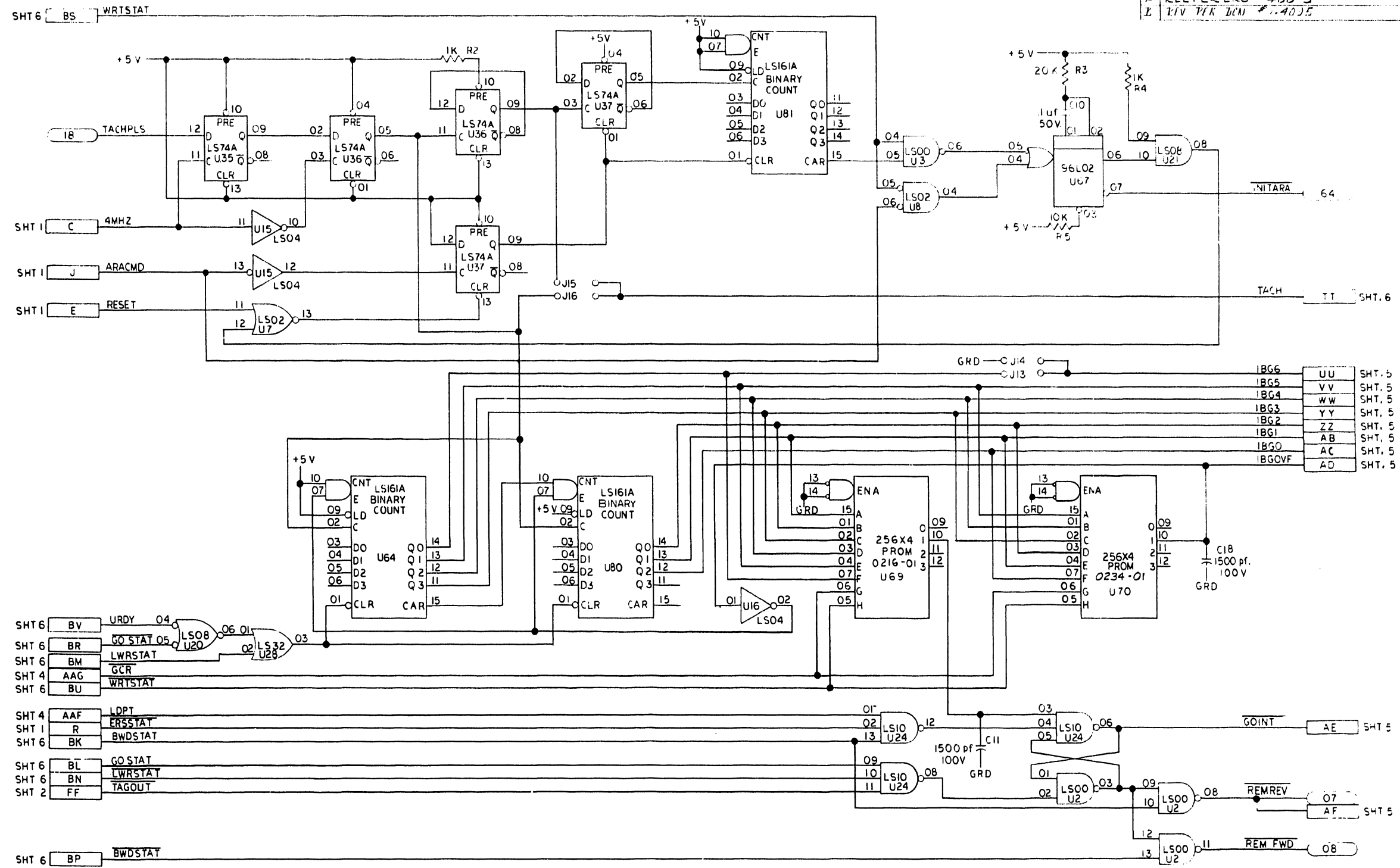

IBG6	UU	SHT. 5
IBG5	VV	SHT. 5
IBG4	WW	SHT. 5
IBG3	YY	SHT. 5
IBG2	ZZ	SHT. 5
IBG1	AB	SHT. 5
IBG0	AC	SHT. 5
IBGOVF	AD	SHT. 5

SHT 6	BY	URDY	04	LS08	06	01	LS32	03
SHT 6	BR	GO STAT	05	LS08	06	01	LS32	03
SHT 6	BM	LWRSTAT	05	LS08	06	01	LS32	03
SHT 4	AAG	GCR						
SHT 6	BU	WRTSTAT						
SHT 4	AAF	LDPT						
SHT 1	R	ERSSTAT						
SHT 6	BK	BWDSTAT						
SHT 6	BL	GO STAT						
SHT 6	BN	LWRSTAT						
SHT 2	FF	TAGOUT						

SHT 6	BP	BWDSTAT						
-------	----	---------	--	--	--	--	--	--

J7

TOLERANCES UNLESS OTHERWISE SPECIFIED	DECIMALS .XX ± 0 — .XXX ± 0 —	ANGULAR ± 30	HOLE DIAMETER .005 — .002	THREAD CLASS NO 2	MATERIAL	FINISH	SCALE	SHEET 3 OF 6
DRAWN GREG GASIEWSKI		DATE 7-24-79	CHECKED LR 11-29-79		DATE	TELEX TULSA OKLAHOMA		
APPROVED D HENDEL RSCN		DATE 11-30-79	LOGIC DIAGRAM, TELEX INTERFACE			CODE IDENT NO	SIZE D	92D722C3
SEE SHT. 1	PART NUMBER	NEXT ASSEMBLY USED ON	APPLICATION	6253				

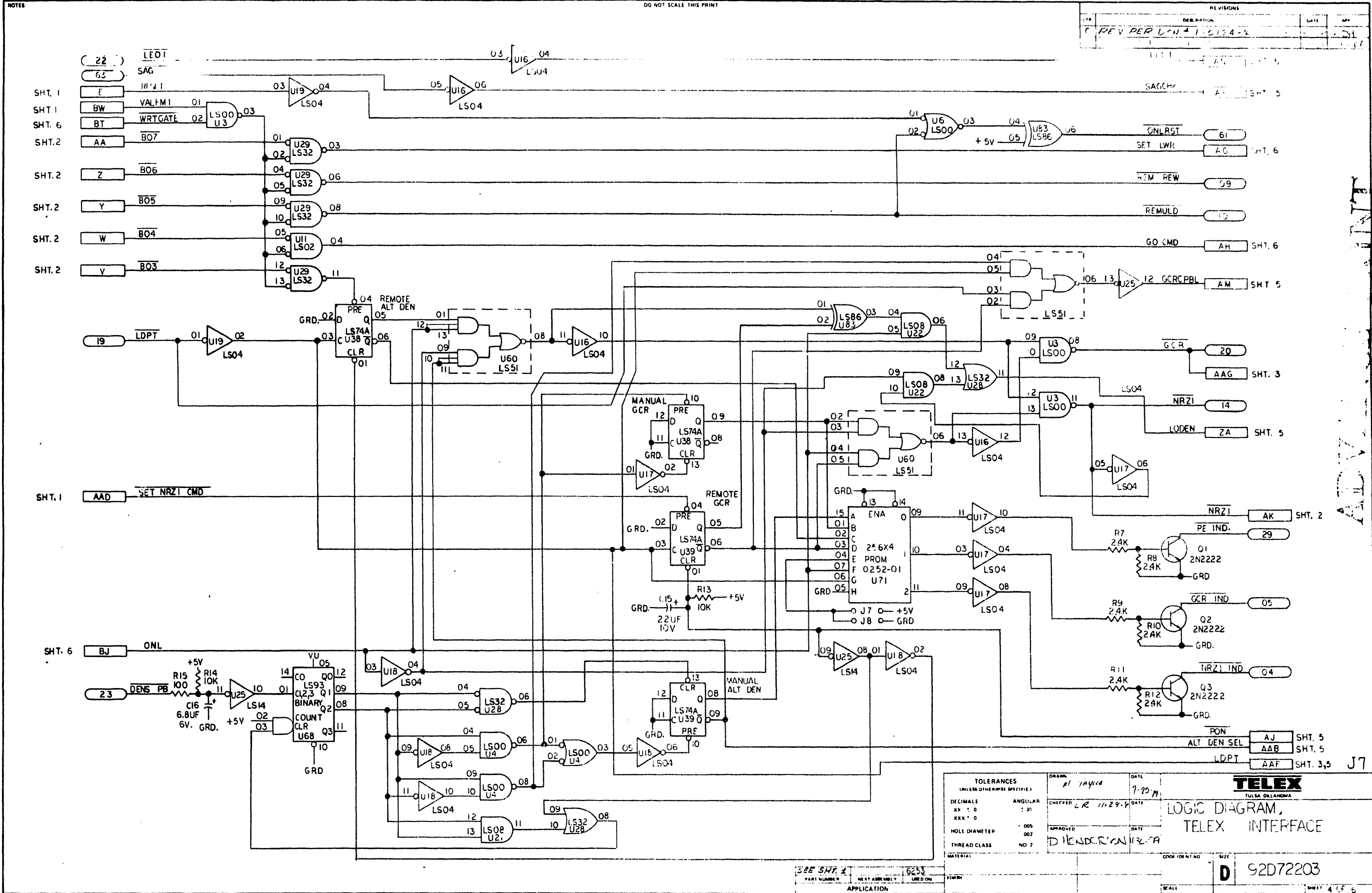

NOTES:

DO NOT SCALE THIS PRINT

REV	DESCRIPTION	DATE	APP
A	REV PER DCN # 1-0134-2	11-29-79	DM
B	REV PER DCN # 1-0136-2	11-29-79	DM
C	REV PER DCN # 1-0134-2	11-29-79	DM
D	REV PER DCN # 1-0134-2	11-29-79	DM

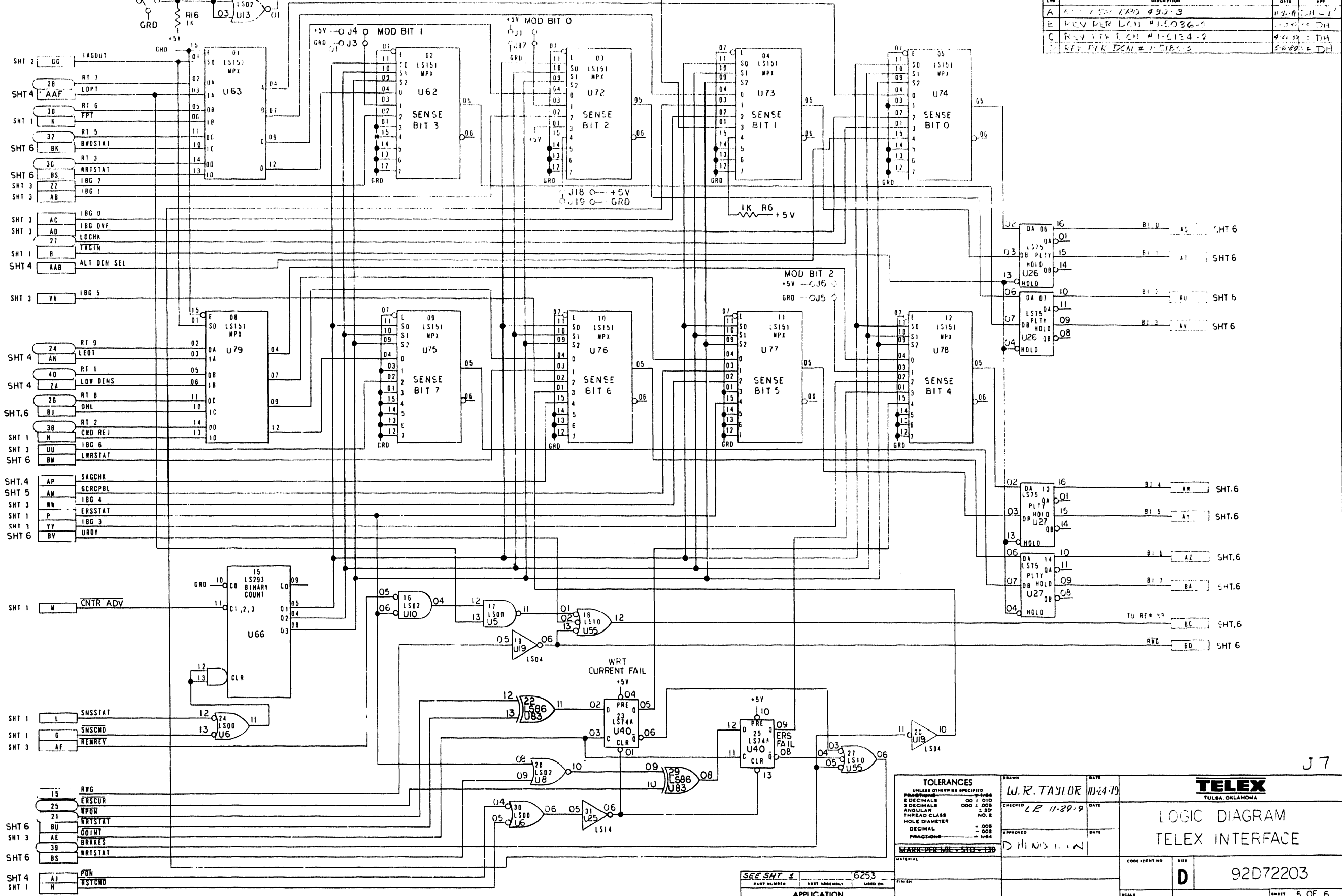

J 7

TOLERANCES UNLESS OTHERWISE SPECIFIED DIMENSIONS: 0.001 ANGULAR: 0.001 HOLE DIAMETER: +0.002 DECIMAL: -0.002 FRACTIONS: -1/64		DRAWN: W.R. TAYLOR DATE: 11-24-79 CHECKED: L.R. 11-29-79 DATE: APPROVED: D. HINDS DATE:	TELEX TULSA, OKLAHOMA LOGIC DIAGRAM TELEX INTERFACE
MATERIAL: MARK PER MIL-STD-130 PART NUMBER: SEE SHT 4 REPT ASSEMBLY: 6253 USED ON: FINISH:	CODE IDENT NO: D SIZE: 92D72203	SCALE:	SHEET 5 OF 6

NOTES:

DO NOT SCALE THIS PRINT

REV	DESCRIPTION	DATE	APP
A	REL PER ERO 480-3	11/21/71	PHL

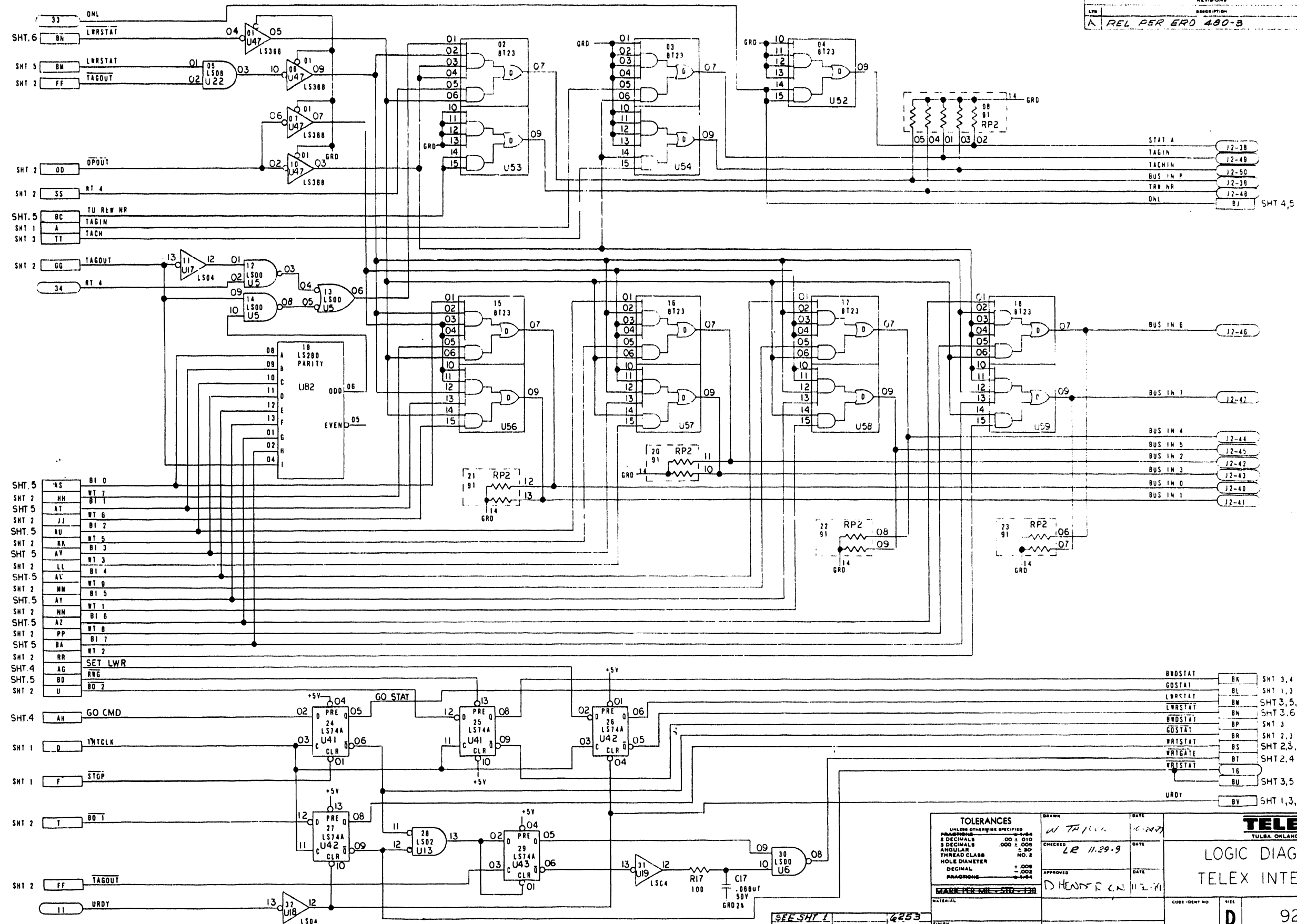

SHT. 5	AS	BI 0
SHT. 2	NN	BI 7
SHT. 5	AT	BI 1
SHT. 2	JJ	WT 6
SHT. 5	AU	BI 2
SHT. 2	RR	WT 5
SHT. 5	AV	BI 3
SHT. 2	LL	WT 3
SHT. 5	AL	BI 4
SHT. 2	NN	WT 9
SHT. 5	AY	BI 5
SHT. 2	NN	WT 1
SHT. 5	AZ	BI 6
SHT. 2	PP	WT 8
SHT. 5	BA	BI 7
SHT. 2	RR	WT 2
SHT. 4	AG	SET LWR
SHT. 5	BD	RRG
SHT. 2	U	BD 2

BROSTAT	BK	SHT 3,4
GOSTAT	BL	SHT 1,3
LRRSTAT	BM	SHT 3,5,6
LWRSTAT	BN	SHT 3,6
BROSTAT	BP	SHT 3
GOSTAT	BR	SHT 2,3
WRSTAT	BS	SHT 2,3,5
WRGATE	BT	SHT 2,4
WRSTAT	BU	SHT 3,5
URDT	BV	SHT 1,3,5

TOLERANCES	
UNLESS OTHERWISE SPECIFIED	
FRACTIONS	± 0.004
DECIMALS	± 0.010
2 DECIMALS	± 0.005
ANGULAR	± 30'
THREAD CLASS	NO. 2
HOLE DIAMETER	+ 0.008
DECIMAL	- 0.002
PLACEMENT	± 0.004

DRAWN	W. Taylor	DATE	11-29-71
CHECKED	LR 11-29-71	DATE	
APPROVED	D. Henry	DATE	11-2-71

TELEX TULSA, OKLAHOMA	
LOGIC DIAGRAM TELEX INTERFACE	
CODE IDENT NO.	D
TITLE	92D72203
SCALE	
SHEET	6 OF 6

SEE SHT 1	6253
PART NUMBER	USED ON
NEXT ASSEMBLY	FINISH
APPLICATION	

NOTES:

DO NOT SCALE THIS PRINT

REVISIONS			
LTN	DESCRIPTION	DA-15	APP
1	FR. MARKS 19	10-1-64	

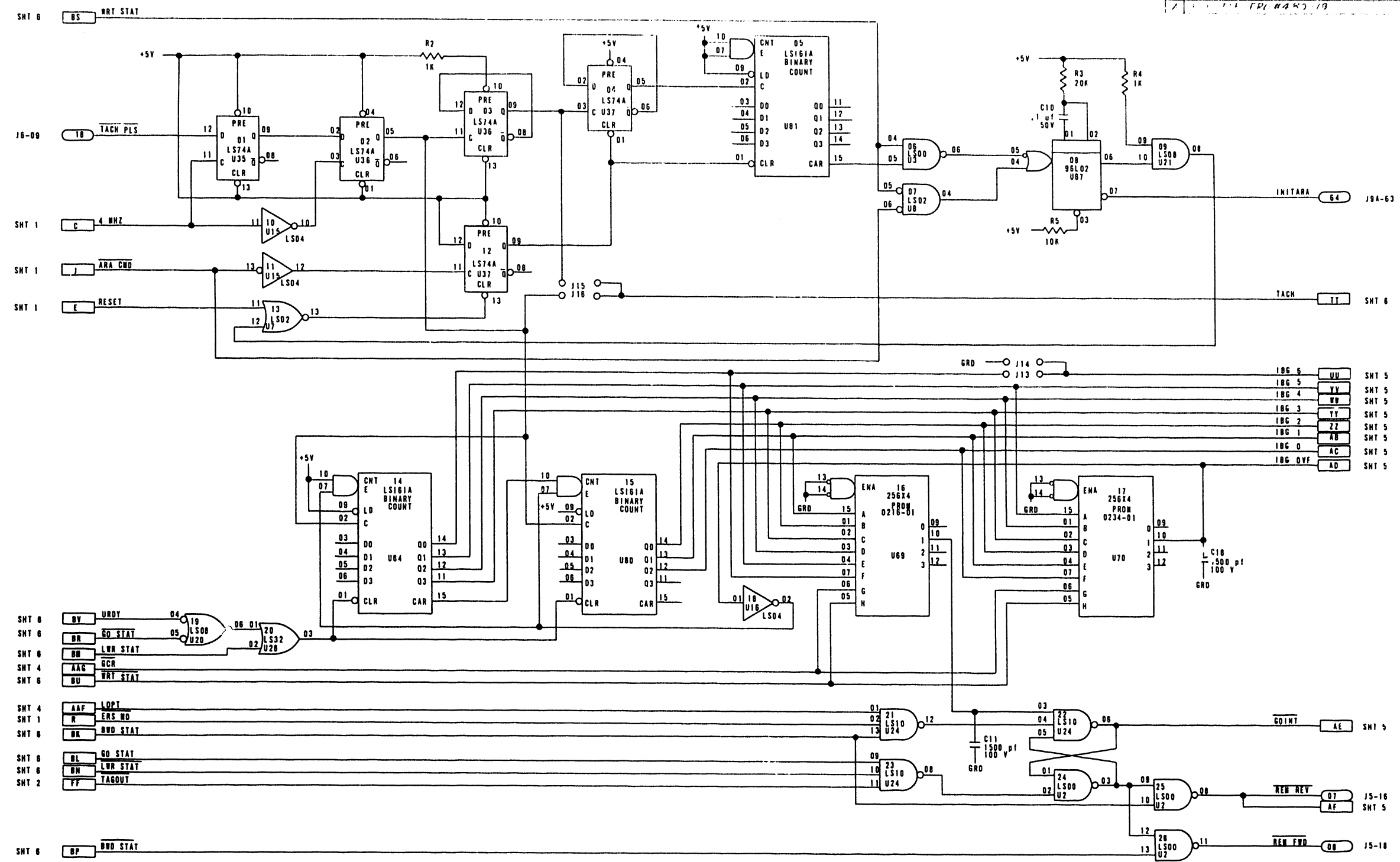

TOLERANCES UNLESS OTHERWISE SPECIFIED		DRAWN	DATE
DECIMALS	ANGULAR	<i>L Randolph</i>	
.XX ± 0	± 30'	CHECKED	DATE
.XXX ± 0		<i>L R 10-30-64</i>	
HOLE DIAMETER	+ .005	APPROVED	DATE
THREAD CLASS	- .002	<i>D. HENDEL</i>	<i>11/3/60</i>
MATERIAL			

SEE SHT 1		4253	
PART NUMBER	NEXT ASSEMBLY	USED ON	FINISH
APPLICATION		CODE IDENT NO	SIZE
			D
		92D72273	
SCALE NONE		SHEET 3 OF 6	

J7

TELEX
TULSA, OKLAHOMA

LOGIC DIAGRAM
TELEX INTERFACE

NOTES

DO NOT SCALE THIS PRINT

REVISIONS			
LTN	DESCRIPTION	DATE	APP
1	REVISED FROM #1-5466-19	11-5-60	DM
2	REVISED FROM #1-5466-2	11-5-60	DM

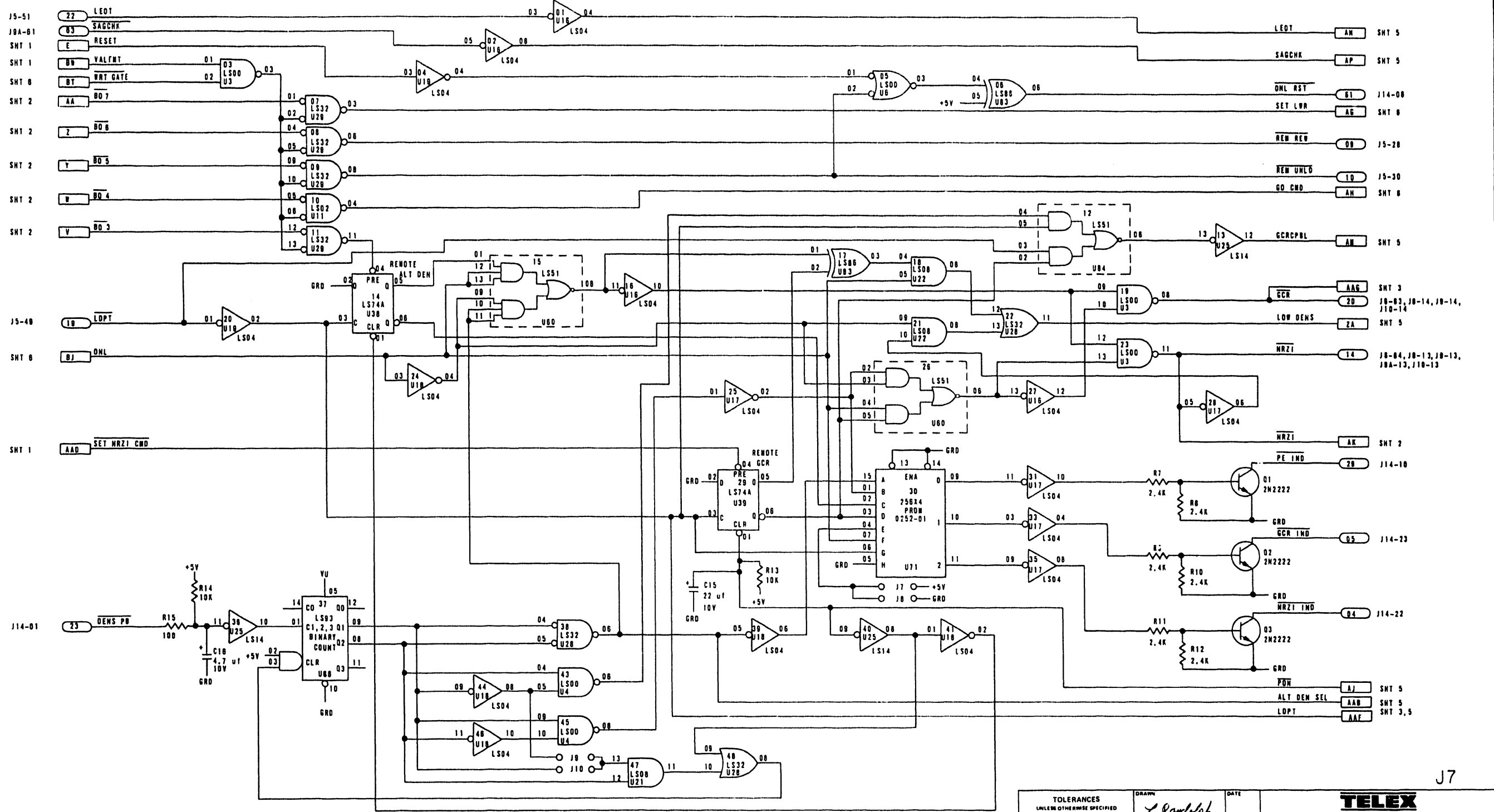

TOLERANCES UNLESS OTHERWISE SPECIFIED		DATE
DECIMALS	ANGULAR	
XX ± 0	± 30'	
XXX ± 0		
HOLE DIAMETER	+ .005	
THREAD CLASS	- .002	
MATERIAL		

DRAWN <i>L Randolph</i> CHECKED <i>CE</i> APPROVED <i>D HENDERSON</i>	DATE 11/10/60 DATE 11/13/60	TELEX TULSA, OKLAHOMA LOGIC DIAGRAM TELEX INTERFACE
CODE IDENT NO D	SIZE 92D72273	SHEET 4 OF 6

SEE SHT 1	W 25 B
PART NUMBER	USE'D ON
NEXT ASSEMBLY	FINISH
APPLICATION	

J7

NOTES

DO NOT SCALE THIS PRINT

REVISIONS			
LTR	DESCRIPTION	DATE	APP

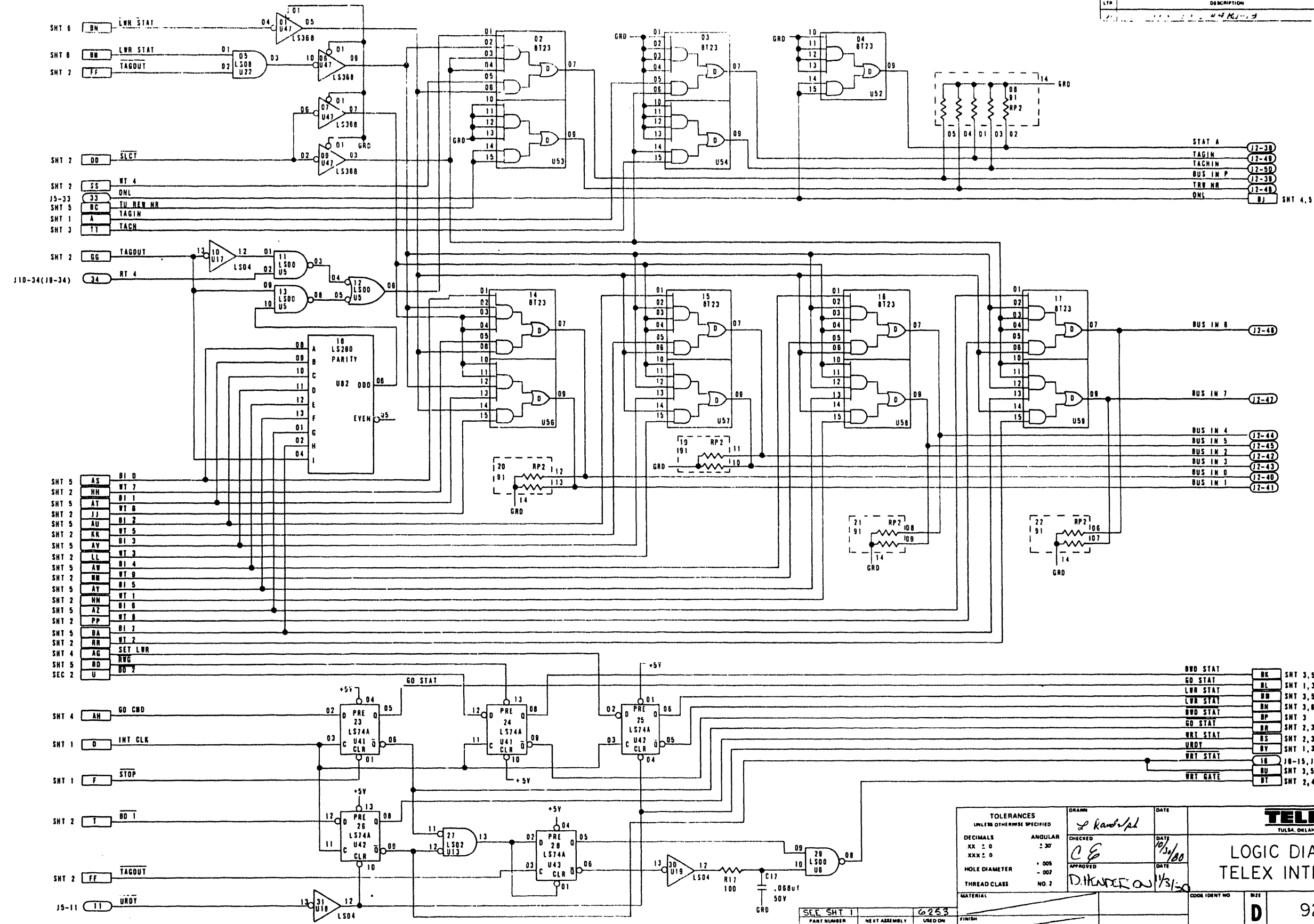

BWD STAT	BK	SHT 3,5
GO STAT	BL	SHT 1,3
LWR STAT	BM	SHT 3,5,6
BWD STAT	BN	SHT 3,6
GO STAT	BP	SHT 3
WRT STAT	BR	SHT 2,3
WRT STAT	BS	SHT 2,3,5
WRT STAT	BT	SHT 1,3,5
WRT STAT	BU	J8-15, J9-15, J8A-15, J10-15
WRT GATE	BT	SHT 2,4

TOLERANCES UNLESS OTHERWISE SPECIFIED		DRAWN	DATE
DECIMALS	ANGULAR	<i>L. Kambel</i>	
XX ± 0	± 30'	CHECKED	DATE
XXX ± 0		<i>CE</i>	<i>10/21/80</i>
HOLE DIAMETER	+ .005	APPROVED	DATE
THREAD CLASS	- .002	<i>D. HENDERSON</i>	<i>11/3/80</i>

J7

TELEX
TULSA, OKLAHOMA

LOGIC DIAGRAM
TELEX INTERFACE

CODE IDENT NO. **D** SIZE **D** 92D72273

SCALE NONE SHEET 6 OF 6

SEE SHT	PART NUMBER	NEXT ASSEMBLY	USED ON	FINISH	APPLICATION
1					

- NOTES
- UNLESS OTHERWISE SPECIFIED:
1 14 PIN I.C. -CONNECT PIN 7 TO GRD
-CONNECT PIN 14 TO 5VDC
 - RESISTORS ARE 1/4W UNLESS OTHERWISE SPECIFIED. VALUES IN OHMS.
 - INTEGRATED CIRCUITS PREFIX 74

DO NOT SCALE THIS PRINT

REVISIONS			
LT#	DESCRIPTION	DATE	APP
A	REL LEP ERO # 480-2	11-17-79	DH LP
B	REV PER DCN 1-5032-1b	2-7-80	6

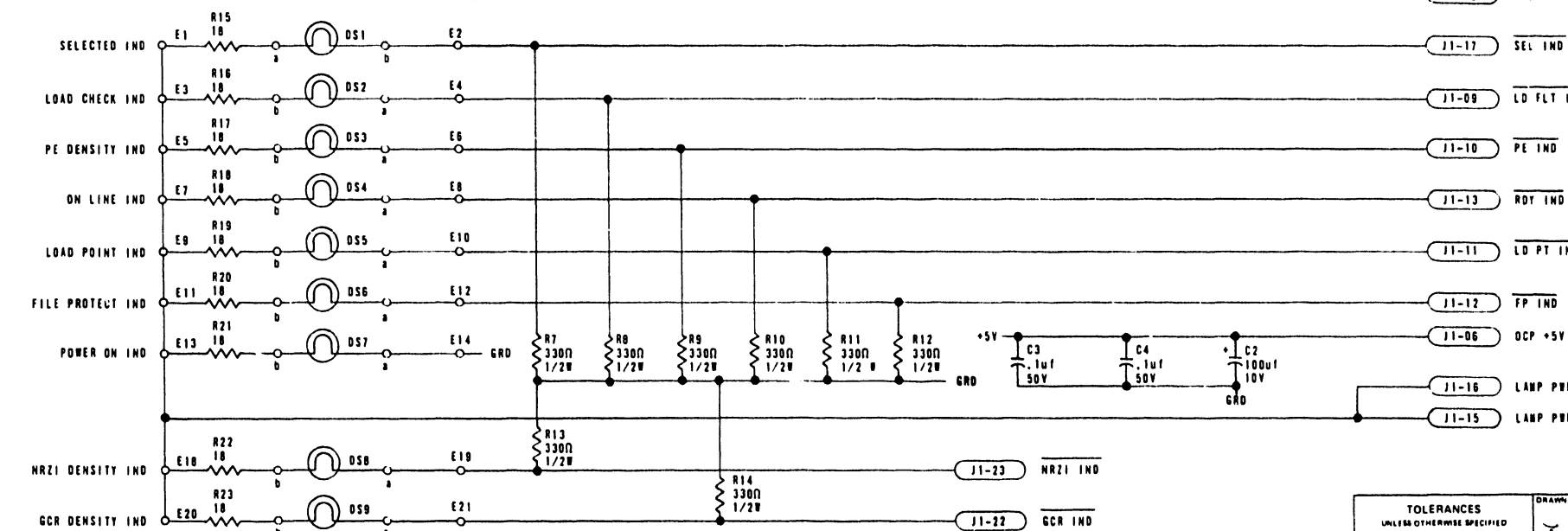
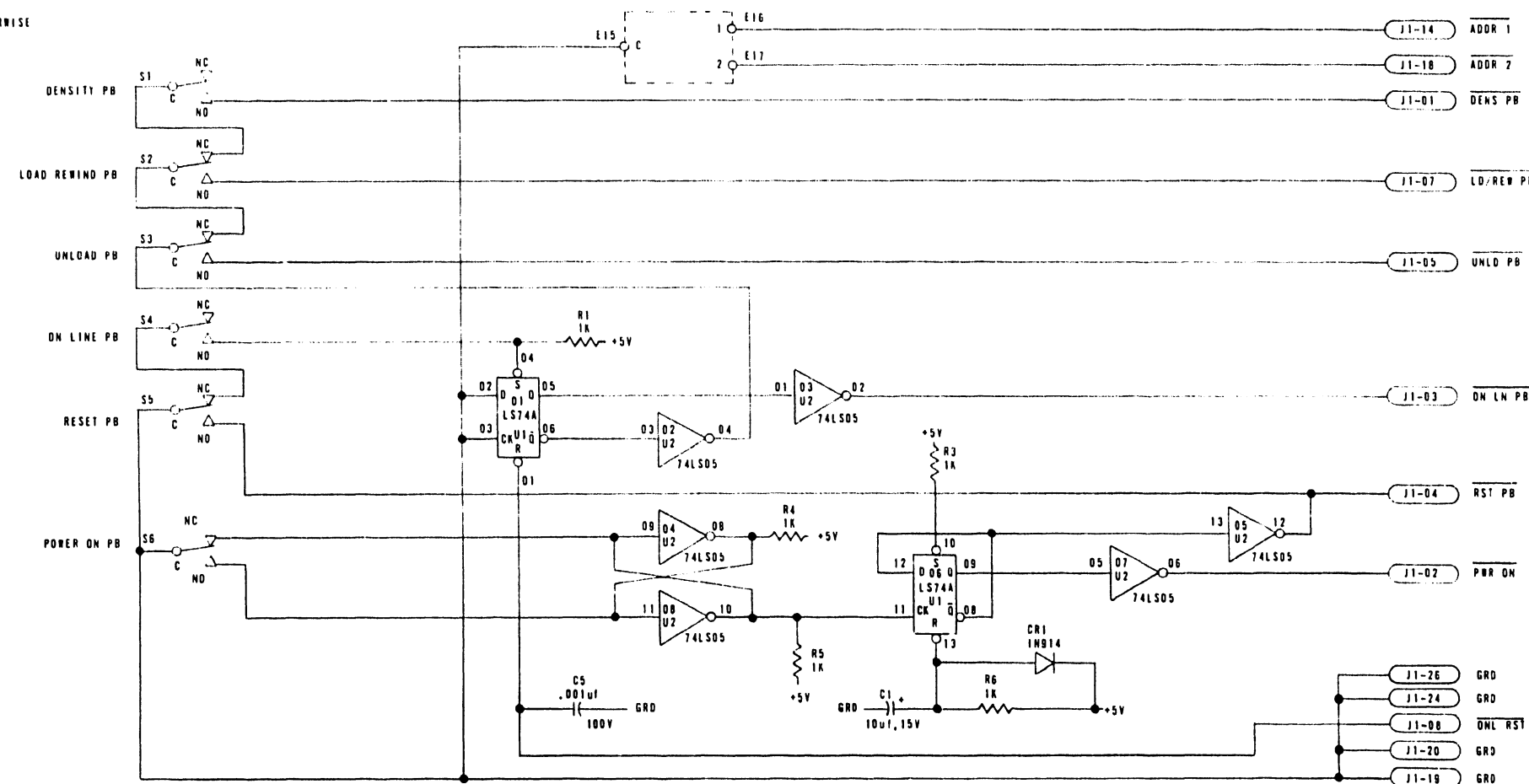

REFERENCE DESIGNATION	
LAST USED	NOT USED
C5	
CR1	
DS9	
J1	
R2	
R23	R2
U2	

TOLERANCES UNLESS OTHERWISE SPECIFIED		DRAWN	DATE	TELEX TULSA, OKLAHOMA
DECIMALS XX ± 0 XXX ± 0	ANGULAR : 30'	CHECKED	DATE	
HOLE DIAMETER	+ .005	APPROVED	DATE	LOGIC DIAGRAM, OPERATOR CONTROL PANEL
THREAD CLASS	- .002	DATE		
MATERIAL				CODE IDENT NO
PART NUMBER		92D72204-01	6253	SIZE
NEXT ASSEMBLY				D
APPLICATION				92D72204
FINISH				SCALE NONE
SHEET 1 OF 1				

NOTES

DO NOT SCALE THIS PRINT

REVISIONS		DATE	BY
1	REV PER ICI 1-5054		
2	REV PER DCA 1-5351-A		

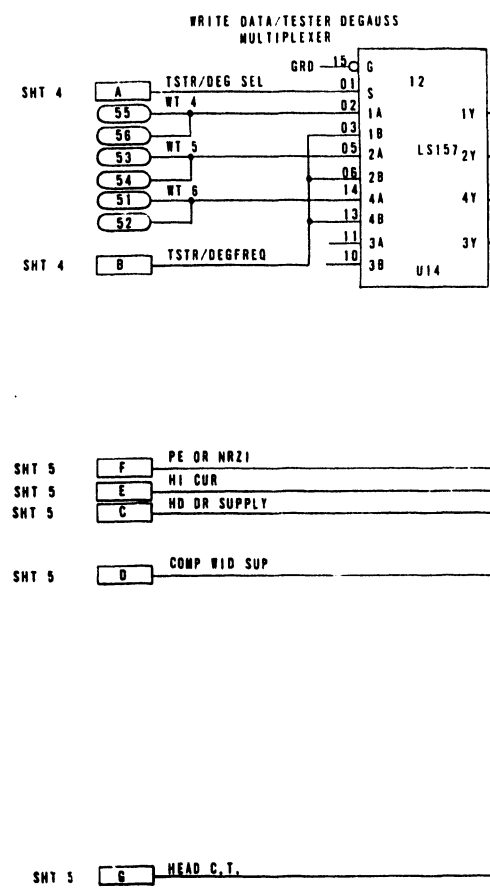
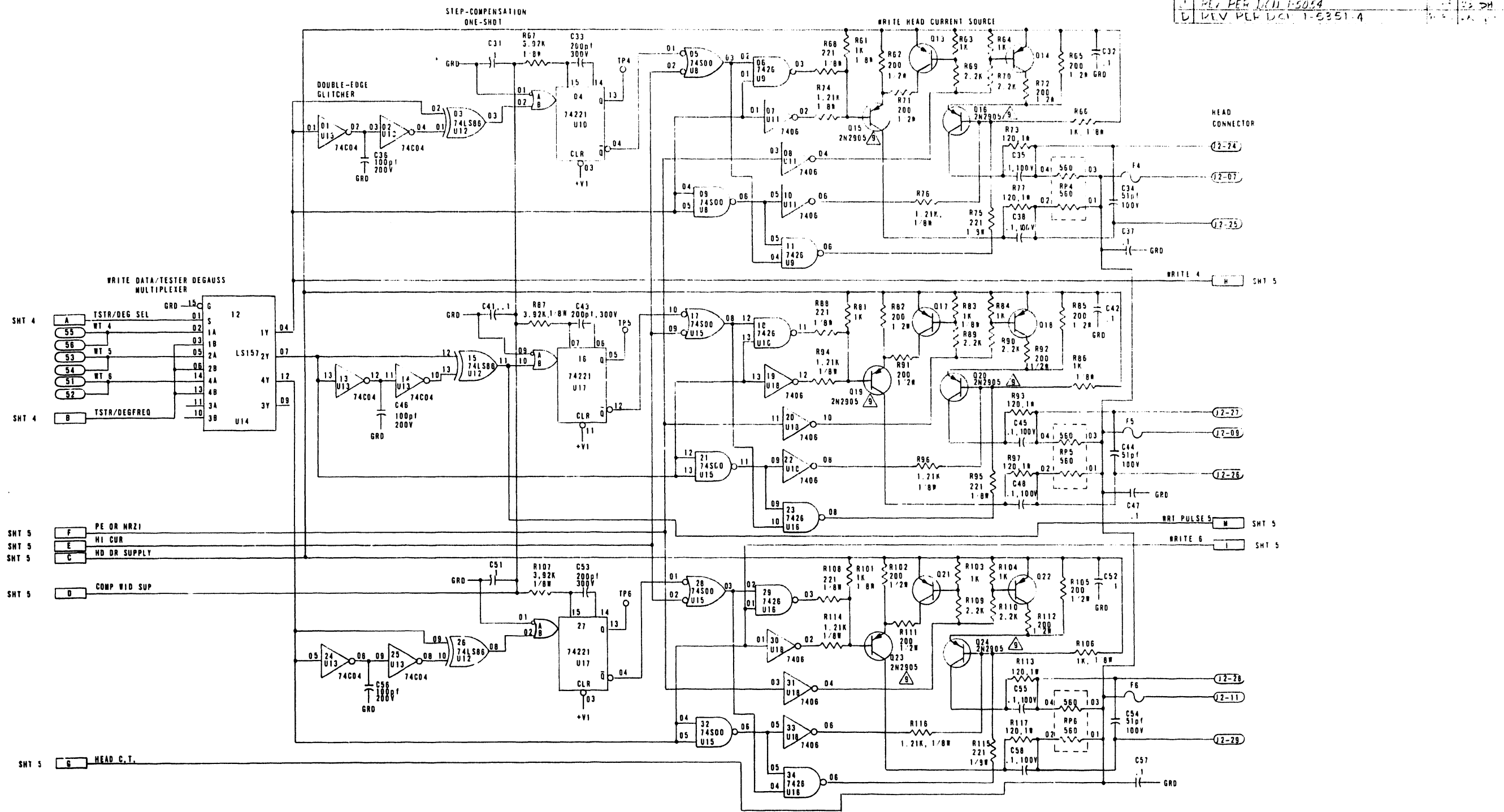

J8

TOLERANCES UNLESS OTHERWISE SPECIFIED		DRAWN <i>Justus</i>	DATE <i>1/3/80</i>
DECIMALS .XX ± 0	ANGULAR ± 30	CHECKED <i>C. Edwards</i>	DATE <i>1/4/80</i>
HOLE DIAMETER - .002	THREAD CLASS NO 2	APPROVED <i>D. Henderson</i>	DATE <i>1/13/80</i>
MATERIAL		CODE IDENT NO	SIZE
SEE SH 1		D	92D72205
PART NUMBER NEXT ASSEMBLY USED ON		SCALE	
APPLICATION		SHEET 2 OF 5	

LOGIC DIAGRAM, WRITE ELECTRONICS

92D72205

NOTES:

DO NOT SCALE THIS PRINT

REVISIONS			
LTR	DESCRIPTION	DATE	APP
C	REV PER DCU 1-5054	6-18-80	CE SH

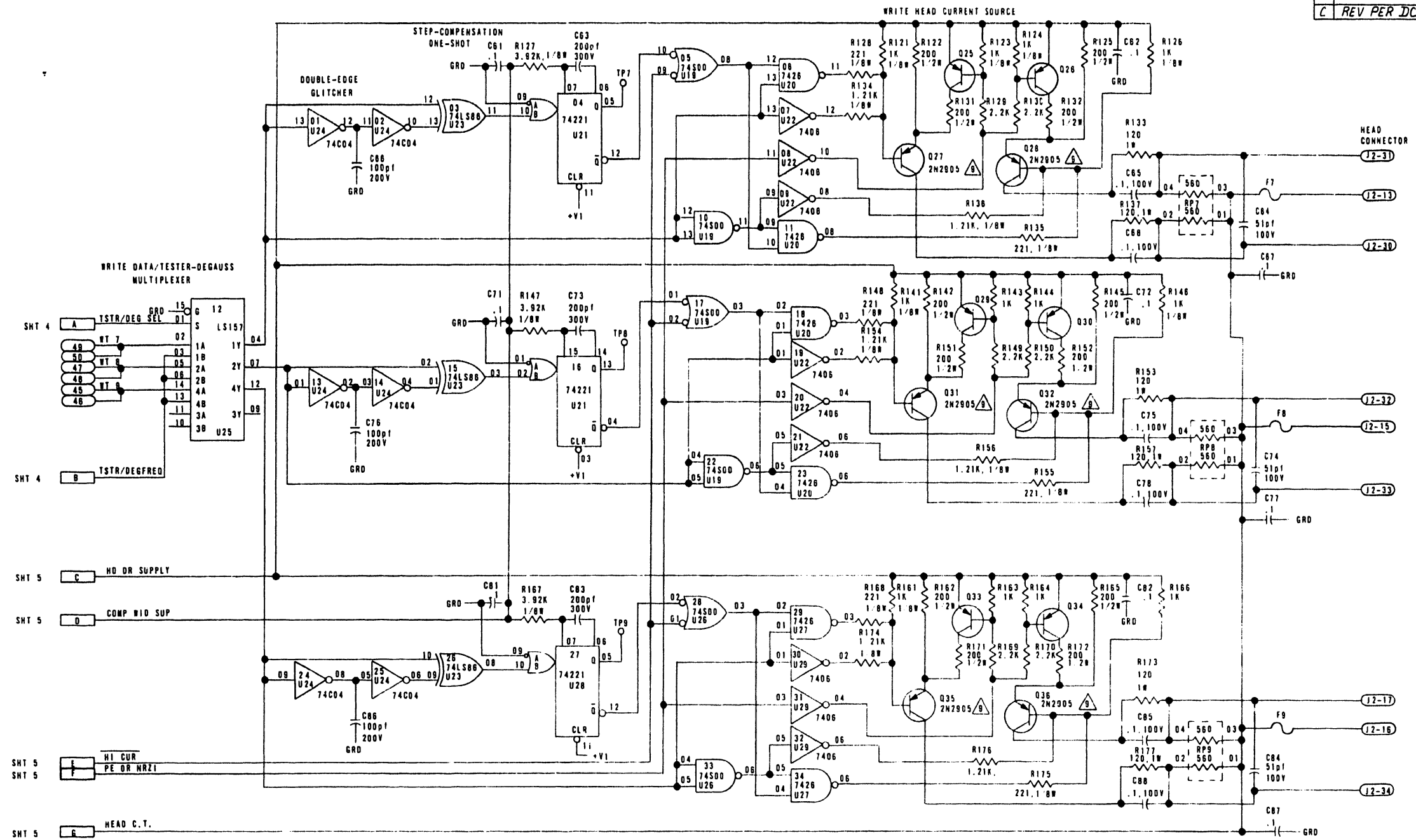

J8

TOLERANCES UNLESS OTHERWISE SPECIFIED		DRAWN W. TAYLOR	DATE 1-31-80	TELEX TULSA, OKLAHOMA
DECIMALS XX : 0	ANGULAR ± 30'	CHECKED C. Edwards	DATE 3/7/80	
HOLE DIAMETER XXX : 0		APPROVED D. HENDERSON	DATE 6/2/80	LOGIC DIAGRAM, WRITE ELECTRONICS
THREAD CLASS NO 2				
MATERIAL				CODE ID# NO D 92D72205
FINISH				SIZE D 92D72205
SCALE				SHEET 3 OF 5

SEE SHT 1	10253
PART NUMBER	NEXT ASSEMBLY USED ON
APPLICATION	

NOTES

DO NOT SCALE THIS PRINT

REVISIONS			
LT#	DESCRIPTION	DATE	APP
2	REV PER J11		PH
1	REV PER DCH 1 5551-4		

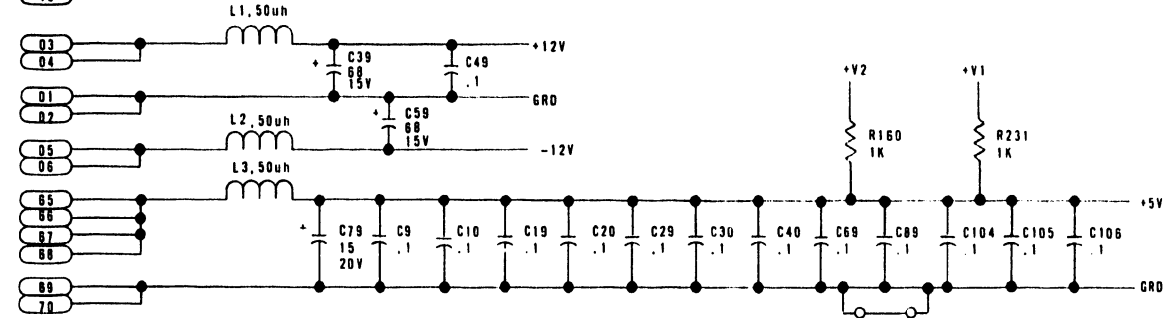
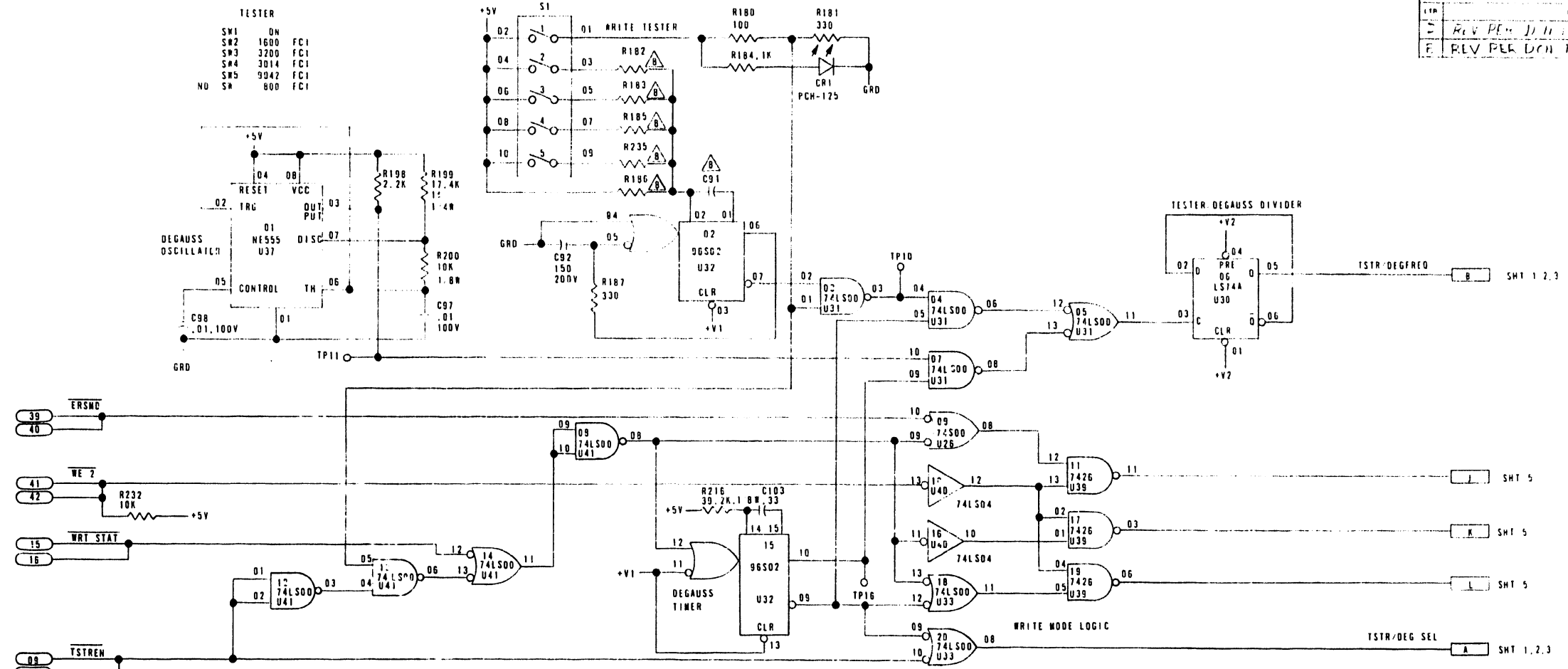

TABLE I

MODEL SPEED	C91	R182	R183	R185	R235	R186	R187 R209	J3
-01(50 IPS)	1800pf	24.9K	8.06K	8.87K	2.21K	25.5K	64.9K	X
-02(75 IPS)	1200pf	24.3K	7.87K	8.45K	2.10K	24.3K	37.4K	X
-04(125 IPS)	820pf	28.1K	8.45K	9.31K	2.21K	26.7K	20.5K	X

SPARE LIST

COMPONENT	REF DESIGN.	SPARE GATES
74500	U26	(11, 12, 13)
74LS04	U40	(03, 04)(05, 06)
7406	U29	(08, 09)(10, 11)(12, 13)
7426	U35	(12, 13)
	U27	(08, 09, 10)(11, 12, 13)
	U39	(08, 09, 10)
LS744	U30	(08, 09, 10, 11, 12, 13)
74LS86	U5	(04, 05, 06)
74221	U23	(04, 05, 06)
560N	U28	(01, 02, 03, 04, 13, 14, 15)
	RP1-9	(05, 06)

J8

TOLERANCES UNLESS OTHERWISE SPECIFIED		DRAWN W. TAYLOR	DATE 2-1-80	TELEX TULSA, OKLAHOMA	
DECIMALS XX : 0 XXX : 0	ANGULAR : 30	CHECKED (Signature)	DATE 3/7/80		
HOLE DIAMETER	+ .005 - .002	APPROVED (Signature)	DATE 4/4/80		
THREAD CLASS	NO 2				
MATERIAL				CODE IDENT NO	SIZE
SEE SHY 1					D
PART NUMBER NEXT ASSEMBLY USED ON					92D72205
APPLICATION				SCALE	SHEET 3 of 3

NOTES

DO NOT SCALE THIS PRINT

REVISIONS			
LTN	DESCRIPTION	DATE	APP
1	REV PER DCU #1-5054	6-8-68	CE/DH
E	REV PER DCU #1-5271-1	7-8-68	CE/DH
F	REV PER DCU #1-5351-4	10-2-68	CE/DH

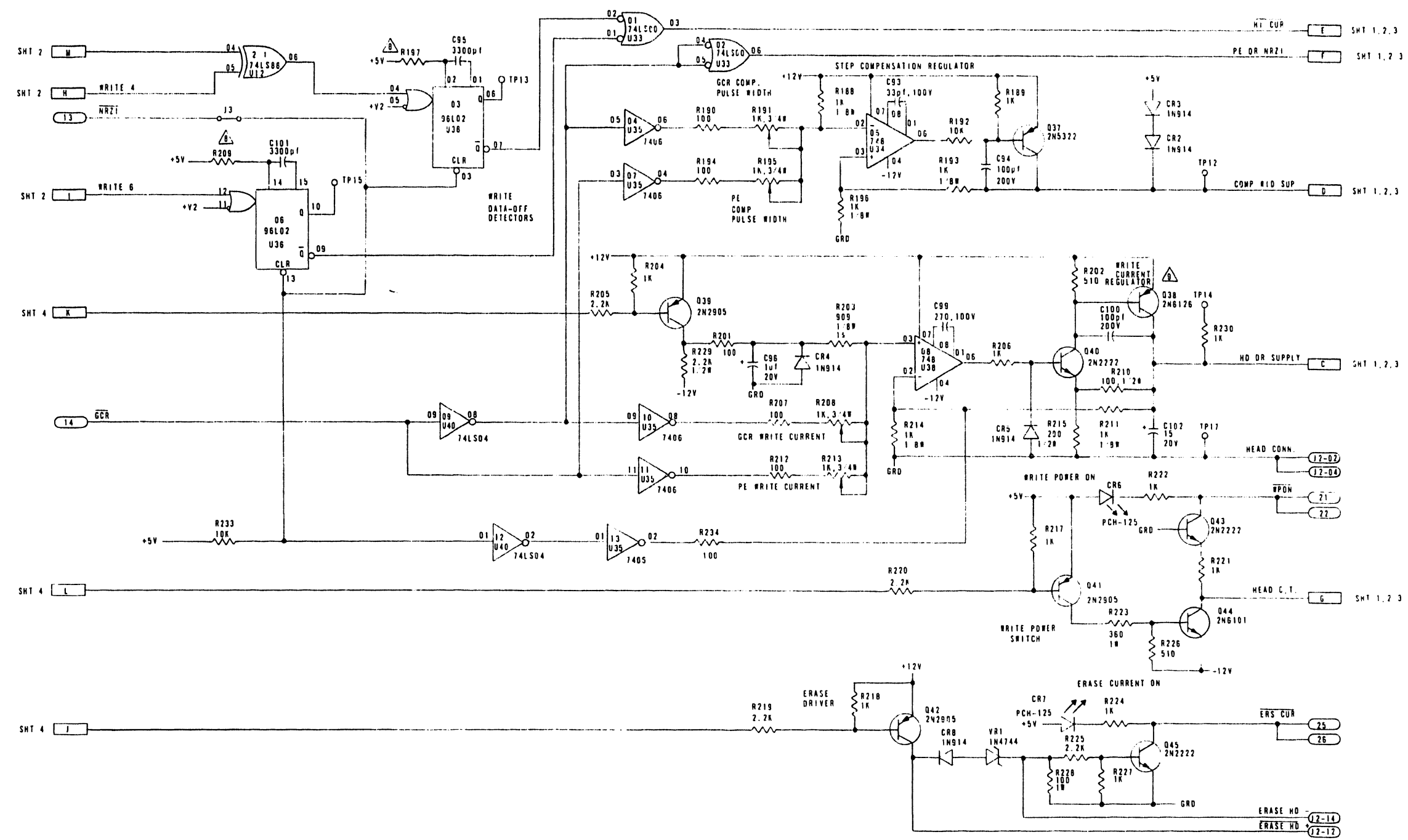

J8

TOLERANCES UNLESS OTHERWISE SPECIFIED		DRAWN <i>Justus</i>	DATE <i>8/10</i>	TELEX TULSA OKLAHOMA
DECIMALS XX ± 0 XXX ± 0	ANGULAR : 30	CHECKED <i>E. Edwards</i>	DATE <i>3/14</i>	
HOLE DIAMETER THREAD CLASS	+ .005 - .002 NO 2	APPROVED <i>D. H. ...</i>	DATE <i>6/14</i>	LOGIC DIAGRAM, WRITE ELECTRONICS
MATERIAL				CODE IDENT NO
FINISH				SIZE D
PART NUMBER <i>SEE SHY 1</i>		NEXT ASSEMBLY <i>6253</i>	USED ON	92D72205
APPLICATION				SCALE
				SHEET <i>5</i> OF <i>5</i>

NOTES:

DO NOT SCALE THIS PRINT

REVISIONS			
LT#	DESCRIPTION	DATE	APP
A	KEL PER DSN #1-5045	30-82	ST
B	KLV PER DCN #1-5350-3	10-15-82	GT

SLOT NO.	CARD NO.	DESCRIPTION
J1	91-71807	REEL POWER AMP
J2	91-71807	REEL POWER AMP
J3	91-71814	CAPSTAN POWER AMP
J4	91-71805	REEL PRE-AMP
J5	91-71835	CONTROL LOGIC
J6	91-71822	CAPSTAN PRE-AMP
J7	91-72203 or 91-72273	TELEX INTERFACE
J8	91-72205	WRITE ELECTRONICS
J9	91-71830	AGC-AMP SENSE
J9A	91-72202	NRZI READ ELECTRONICS
J10	91-72201	PE-GCR READ ELECTRONICS

CARD NO.	SLOT NO.	MOD 33 50 IPS	MOD 44 75 IPS	MOD 66 125 IPS	MOD 233 50 IPS	MOD 244 75 IPS	MOD 258 125 IPS
91-71805-01	J4	X	X	X	X	X	X
91-71807-01	J1	X	X	X	X	X	X
91-71807-01	J2	X	X	X	X	X	X
91-71814-01	J3	X	X	X	X	X	X
91-71822-01	J6		X	X		X	X
91-71822-04	J6	X			X		
91-71830-01	J9	X					
91-71830-02	J9		X				
91-71830-04	J9			X			
91-71830-01	J9A				X		
91-71830-02	J9A					X	
91-72830-04	J9A						X
91-72835-01	J5	X	X	X	X	X	X
91-72201-01	J10	X			X		
91-72201-02	J10		X			X	
91-72201-04	J10			X			X
91-72202-01	J9A	X					
91-72202-02	J9A		X				
91-72202-04	J9A			X			
91-72203-01	J7	X					
91-72203-02	J7		X				
91-72203-04	J7			X			
91-72273-04	J7				X		
91-72273-05	J7					X	
91-72273-06	J7						X
91-72205-01	J8	X			X		
91-72205-02	J8		X			X	
91-72205-04	J8			X			X

DESCRIPTION	CARD NO.	SLOT NO.
AGC-AMP SENSE	91-71830	J9
CAPSTAN POWER AMP	91-71822	J3
CAPSTAN PRE-AMP	91-71814	J6
CONTROL LOGIC	91-71835	J5
NRZI READ ELECTRONICS	91-72202	J9A
PE-GCR READ ELECTRONICS	91-72201	J10
REEL POWER AMP	91-71807	J1
REEL POWER AMP	91-71807	J2
REEL PRE-AMP	91-71805	J4
TELEX INTERFACE	91-72203 or 91-72273	J7
WRITE ELECTRONICS	91-72205	J8

INDEX

TOLERANCES UNLESS OTHERWISE SPECIFIED		DRAWN <i>CE</i>	DATE 1/25/80	TELEX TULSA, OKLAHOMA
DECIMALS XX ± 0 XXX ± 0	ANGULAR ± 30'	CHECKED <i>(Signature)</i>	DATE 1/30/80	
HOLE DIAMETER + .005 - .002		APPROVED	DATE	LOGIC DIAGRAM (CARD INDEX)
THREAD CLASS NO 2		<i>(Signature)</i>		
MATERIAL				CODE IDENT NO D
PART NUMBER 35A20474 6253	NEXT ASSEMBLY	USED ON	FINISH	SIZE 92D72206
APPLICATION				SCALE
				SHEET

WANG

LABORATORIES, INC

ONE INDUSTRIAL AVENUE, LOWELL, MASSACHUSETTS 01851, TEL. (617) 459-5000, TWX 710 343-6769, TELEX 94-7421

PRINTED IN U.S.A.

COMPANY CONFIDENTIAL

END