

WANG

3302

MATRIX PRINTER

Models:

200W	2221W
621W	5521
721W	

**Customer Engineering
Product Maintenance Manual**

729-0318-A

Second Edition (May 1983)

This publication is a reprint of 729-0318 incorporating 729-0192, 729-0324, 729-0327, 729-0328, 729-0337, and 729-0854. Updates or changes made to the information in this publication will be published as PSNs or a subsequent edition.

This document is the property of Wang Laboratories, Inc. All information contained herein is considered company proprietary information, and its use is restricted solely to the purpose of assisting you in servicing Wang products. Reproduction of all or any part of this document is prohibited without the prior consent of Wang Laboratories Inc.

© Copyright WANG Labs., Inc. 1976, 1983

TABLE OF CONTENTS

SECTION 1 INTRODUCTION

1.1	SCOPE	1-1
1.2	DESCRIPTION	1-2
1.3	MODEL 72 TECHNICAL CHARACTERISTICS	1-3

SECTION 2 INSTALLATION

2.1	SITE CONSIDERATIONS	2-1
2.2	MATRIX PRINTER STAND (OPTIONAL)	2-1
2.3	UNPACKING AND PACKING PROCEDURES	2-1
2.3.1	UNPACKING	2-1
2.3.2	PACKING	2-4
2.4	SET UP PROCEDURE	2-4
2.5	UNIT INSPECTION PROCEDURE	2-6
2.6	OPERATOR CONTROLS AND INDICATORS	2-6
2.7	DYNAMIC CHECKOUT	2-9

SECTION 3 OPERATION

3.1	VERTICAL FORMAT UNIT	3-1
3.2	RIBBON REMOVAL AND REPLACEMENT	3-4
3.2.1	REMOVAL	3-4
3.2.2	REPLACEMENT	3-5
3.3	2200 OPERATION	3-5
3.3.1	DEVICE ADDRESS CODES	3-5
3.3.2	SELECT STATEMENTS	3-6
3.3.3	LINE LENGTH	3-9
3.3.4	TAB FUNCTION	3-10
3.3.5	EXPAND FUNCTION: HEX (ØE)	3-10
3.3.6	ZONES	3-12
3.3.7	HEX FUNCTION	3-12
3.3.8	CONTROL CODES	3-13
3.4	621W, 721W AND 1222 LINE PRINTER OPTION (LPO)	3-13

SECTION 4 THEORY OF OPERATION

4.1	INTRODUCTION	4-1
4.2	GENERAL	4-1
4.2.1	CARRIAGE MOVEMENT	4-1
4.2.2	PAPER MOVEMENT	4-2
4.2.3	RIBBON MOVEMENT	4-3
4.3	ELECTRICAL THEORY	4-4
4.3.1	6577 FORMAT AND PRINTING CONTROL BOARD	4-4
4.3.1.1	Carriage Movement	4-4
4.3.1.2	Ribbon Movement	4-6
4.3.1.3	Paper Movement	4-7

4.3.2	6728 MEMORY AND REGULATOR BOARD	4-11
4.3.2.1	General	4-11
4.3.2.2	Logic Description	4-12
4.3.2.3	Sequence of Operations	4-13
4.3.2.4	Circuit Functions	4-18
4.3.2.5	Power Supply Circuit	4-19
4.3.3	6576 I/O CONTROL AND DATA STORAGE BOARD	4-20
4.3.3.1	6576 Operation	4-20
4.3.3.2	Power-On-Prime	4-21
4.3.3.3	Other Prime Conditions	4-21
4.3.3.4	Prime Circuit	4-21
4.3.3.5	Select Circuit	4-23
4.3.3.6	Print Buffer Loading	4-23
4.3.3.7	BUSY/READY Circuit	4-24
4.3.3.8	Print Cycle	4-25
4.3.3.9	Audio Alarm	4-27
4.3.3.10	Cover Open	4-27
4.3.3.11	Paper-Out Switch	4-27
4.3.3.12	Form Override	4-28
4.3.3.13	Ribbon Delay	4-28
4.3.3.14	Line Feed Delay	4-28
4.3.4	MODIFICATION OF 6576 AND 6728 BOARDS	4-28

SECTION 5 ADJUSTMENT, REMOVAL AND REPLACEMENT PROCEDURES

5.1	INTRODUCTION	5-1
5.2	ELECTRICAL ADJUSTMENTS	5-1
5.3	MECHANICAL AND ELECTROMECHANICAL ADJUSTMENT, REMOVAL/ REPLACEMENT INDEX	5-5
5.3.1	STRIKER BAR	5-5
5.3.2	RIBBON GUIDES	5-7
5.3.3	MAIN DRIVE BELT	5-8
5.3.4	PAPER GUIDES	5-10
5.3.5	PRINT HEAD ADJUSTMENT	5-16
5.3.6	TIMING FENCE	5-19
5.3.7	REED SWITCHES	5-23
5.3.8	REED SWITCH MAGNET	5-25
5.3.9	PAPER FEED SPROCKETS	5-26
5.3.10	VERNIER CLUTCH	5-28
5.3.11	VERTICAL FORMAT UNIT (VFU)	5-30
5.3.12	RIBBON DRIVE ASSEMBLY	5-34
5.3.13	PAPER MOVEMENT BELTS	5-37
5.3.14	TACHOMETER AND DRIVE MOTOR ADJUSTMENTS	5-40
5.3.15	CARRIAGE ASSEMBLY REMOVAL AND REPLACEMENT	5-42
5.3.16	FRAME ASSEMBLY REMOVAL AND REPLACEMENT	5-44
5.3.17	COVER REMOVAL AND REPLACEMENT	5-45
5.3.18	CARRIAGE GUIDE SHAFT REMOVAL AND REPLACEMENT	5-45

SECTION 6 MAINTENANCE

6.1	INTRODUCTION	6-1
6.2	DIAGNOSTICS	6-1

6.2.1	LONG VERSION DIAGNOSTIC	6-1
6.2.2	TEST FUNCTION DESCRIPTIONS FOR MODEL 72	6-2
6.2.3	SHORT VERSION DIAGNOSTIC	6-12
6.3	PREVENTIVE MAINTENANCE	6-19
6.3.1	VISUAL CHECKS	6-19
6.3.2	ADJUSTMENTS	6-19
6.3.3	LUBRICATION	6-19
6.4	TROUBLESHOOTING	6-21
6.4.1	TROUBLESHOOTING HINTS	6-21
6.4.2	MISCELLANEOUS TROUBLESHOOTING AIDS	6-25

SECTION 7 ELECTRICAL SCHEMATICS

7.1	INTRODUCTION	7-1
7.2	LIST OF ELECTRICAL SCHEMATICS	7-1
7.3	SIGNAL RUN LIST (3 SHTS)	7-1

SECTION 8 MECHANICAL ASSEMBLY DRAWINGS

8.1	INTRODUCTION	8-1
8.2	ASSEMBLY DRAWINGS	8-1

APPENDIX A	PAPER SPECIFICATIONS	A-1
APPENDIX B	HEXADECIMAL CODES	B-1
APPENDIX C	SIGNAL MNEMONICS	C-1
APPENDIX D	MODEL 72 CHARACTER SET	D-1

LIST OF ILLUSTRATIONS

<u>FIGURE</u>	<u>DESCRIPTION</u>	<u>PAGE NO.</u>
1-1	MODEL 72 HIGH SPEED PRINTER	1-1
2-1	UNPACKING THE PRINTER	2-2
2-2	REMOVAL OF PACKAGING TAPE	2-3
2-3	PRINTER WITH PAPER RACK	2-4
2-4	ACOUSTIC HOOD AND SUPPORT ROD FOR PAPER RACK	2-5
2-5	CONTROL PANEL	2-7
2-6	PRINTER (REAR VIEW)	2-8
2-7	FORMS THICKNESS CONTROL	2-8
3-1	VERTICAL FORMAT TAPE	3-2
3-2	TAPE FLOW AND SPLICING SQUARE	3-3
3-3	FORMAT TAPE GUIDE	3-4
3-4	RIBBON REMOVAL AND REPLACEMENT	3-5
4-1	CARRIAGE SERVO MOTOR	4-2
4-2	RIBBON DRIVE MOTOR CONTROL	4-4
4-3	WINDOW STROBE (WS) ADJUSTMENT	4-7
4-4	STEPPER MOTOR CONTROL FOR PAPER MOVEMENT	4-8
4-5	STEPPER MOTOR CONTROL PULSES	4-9
4-6	ALIGNMENT OF TAPE FORMAT AND LINE FEED ENABLE	4-11
4-7	BLOCK DIAGRAM OF 6728/7028 BOARD	4-12
4-8	TIMING DIAGRAM FOR ACTIVATING PRINT SOLENOID STROBES AND COLUMN COUNTER	4-15
4-9	BLOCK DIAGRAM OF 6576/7076 BOARD	4-20
4-10	MARKER BIT GENERATOR	4-22
5-1	VOLTAGE AND WS TIMING ADJUSTMENTS	5-2
5-1A	ELECTRICAL CHASSIS ASSEMBLY LAYOUT	5-3
5-2	STRIKER BAR ADJUSTMENT	5-5
5-3	RIBBON GUIDES AND PRINT HEAD ADJUSTMENT	5-8
5-4	MAIN DRIVE BELT ADJUSTMENT	5-9
5-5	MAIN DRIVE BELT REMOVAL AND REPLACEMENT	5-10

<u>FIGURE</u>	<u>DESCRIPTION</u>	<u>PAGE NO.</u>
5-6	MODEL 72 PAPER GUIDE DESIGNS	5-11
5-7	PAPER GUIDE ADJUSTMENTS	5-12
5-8	EARLY MODEL PAPER GUIDE ADJUSTMENT	5-14
5-9	SOLENOID WIRE ADJUSTMENT	5-17
5-10	IDENTIFICATION OF SOLENOIDS	5-17
5-11	REMOVAL AND REPLACEMENT OF SOLENOIDS	5-18
5-12	TIMING FENCE ADJUSTMENT CHECKS	5-20
5-13	TIMING FENCE ADJUSTMENTS (HEIGHT AND PARALLELISM)	5-21
5-14	PHOTOCOUPLER REMOVAL AND REPLACEMENT	5-22
5-15	REED SWITCH ADJUSTMENTS	5-24
5-16	REED SWITCH MAGNET ADJUSTMENT	5-25
5-17	PAPER FEED SPROCKET ADJUSTMENTS	5-26
5-18	PAPER FEED SPROCKET REMOVAL AND REPLACEMENT	5-27
5-19	VERNIER CLUTCH ADJUSTMENTS	5-29
5-20	VERTICAL FORMAT UNIT ADJUSTMENTS	5-30
5-21	VFU AND STEPPER MOTOR PHASE CHECK	5-32
5-22	VERTICAL FORMAT HOUSING ADJUSTMENTS	5-33
5-23	VERTICAL FORMAT SPROCKET ALIGNMENT	5-33
5-24	RIBBON DRIVE ASSEMBLY ADJUSTMENTS	5-35
5-25	RIBBON TENSION ARMS (CHECKS AND ADJUSTMENTS)	5-36
5-26	RIBBON HEIGHT AND ANGLE ADJUSTMENTS	5-36
5-27	PAPER SPROCKET DRIVE BELT	5-38
5-28	STEPPER MOTOR TIMING BELT ADJUSTMENT	5-39
5-29	TACHOMETER BELT TENSION CHECK	5-40
5-30	DRIVE MOTOR AND CARRIAGE DRIVE BELT CHECK	5-41
5-31	DRIVE MOTOR AND TACHOMETER BELT ADJUSTMENTS	5-42
5-32	CARRIAGE ASSEMBLY REMOVAL AND REPLACEMENT	5-43
5-33	FRAME ASSEMBLY REMOVAL AND REPLACEMENT	5-45

LIST OF TABLES

5-1	ELECTRICAL ADJUSTMENTS	5-3
5-2	ELECTRICAL CIRCUIT BOARDS	5-4
6-1	TROUBLESHOOTING HINTS	6-21

SECTION

1

INTRO-

DUCTION

SECTION 1
INTRODUCTION

1.1 SCOPE

This manual describes the Model 72 High Speed Printer manufactured by Wang Laboratories, Inc.

General information, detailed theory of operation and maintenance routines are included to enable Customer Engineering personnel and operators to maintain the printer.

The manual is arranged in the following manner:

- SECTION 1 - INTRODUCTION: Provides the reader with the scope of this manual and a general description of the printer.
- SECTION 2 - INSTALLATION: Contains unpacking and installation instructions for the printer.
- SECTION 3 - OPERATION: Describes the function of all operator controls and indicators including the basic 2200 CPU operations for outputting data.
- SECTION 4 - THEORY OF OPERATION: Contains detailed electronic descriptions of the printed circuit boards.
- SECTION 5 - ADJUSTMENTS, REMOVAL AND REPLACEMENT PROCEDURES.
- SECTION 6 - MAINTENANCE: Includes diagnostics, preventive maintenance and troubleshooting tables.
- SECTION 7 - ELECTRICAL SCHEMATICS: Contains a complete set of schematics, wiring and interconnection diagrams.
- SECTION 8 - MECHANICAL ASSEMBLY DRAWINGS: Allows the user to identify any part of the printer.

1.2 DESCRIPTION (SEE FIGURE 1-1)

The Model 72 [which is marketed as a 200W, 621W, 721W, 2221W and 1222 Line Printer Option (LPO)] uses a matrix impact printing technique that generates printed characters in matrix form. The characters are composed by a 9 x 10 matrix and print lines up to 132 characters long using a 96 character set. The printer operates at a rate of 200 characters per second and can achieve a rate of 65 to 300 lines per minute dependent upon line length. Characters are printed 6 lines and 10 characters to the inch (2.4 lines/cm and 4.3 characters/cm) with an expand feature that doubles the width of the characters.

NOTE:

The Model 200W Printer can also be maintained by this manual having the same or similar characteristics within 95% of the Models listed above.

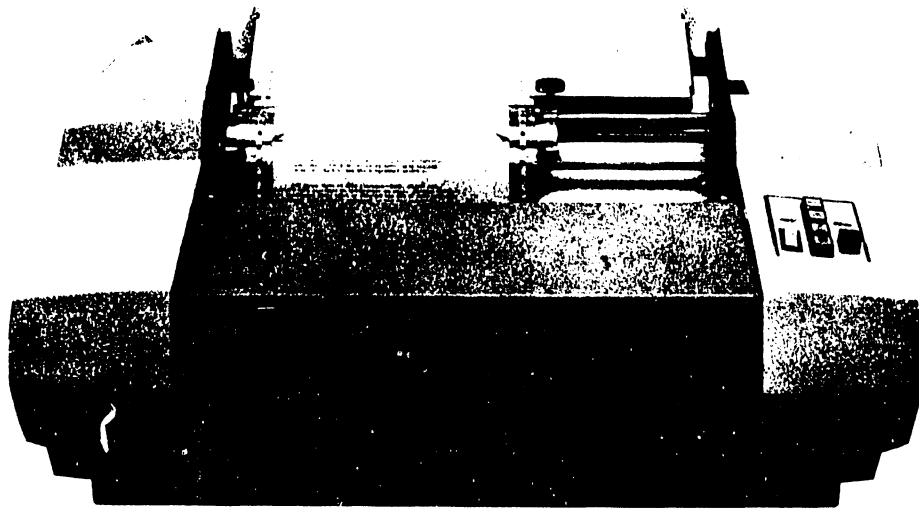

1.3 MODEL 72 TECHNICAL CHARACTERISTICS

Printing Rate: Characters/Second - 200
Lines/Minute - 65-300 LPM

Data Input: (Language) USASCII

Character Font: 9 x 10 Dot Matrix Nominal (dots not
in adjacent columns of the same row)

Paper Dimensions and Specs: See Appendix A

Dimensions: Height: 12 inches (31 cm)
Width: 29 inches (74 cm)
Depth: 25 inches (64 cm)

Operating Temperature: 50° to 90°F (10° to 32°C)

Humidity: 40 to 80% Relative, non-condensing
115 VAC +10% 230 VAC +10%

Power Source: 50/60 cycle +1 Hz 115 or 230 VAC +10%
300 watts 300 watts
NOTE: Internal Selection

Weight (Approx.): 85 lbs. (38.6 kg)

Storage Temperature: -40° to 130°F (-40 to 55°C)

Storage Humidity: 0 to 90% Relative, non-condensing

Noise Volume: 65 DB Without Silencer Hood
50-53 DB With Silencer Hood

SECTION

2

INSTAL-

LATION

SECTION 2 INSTALLATION

2.1 SITE CONSIDERATIONS

Consider the dimensions of the printer with side covers open so that the machine will not have to be moved when the ribbon is changed or a new format tape is installed. Also the ventilation fan intake screen should not be obstructed by any objects which could reduce normal airflow. For environmental temperature, humidity, etc., see technical characteristics in paragraph 1.3.

2.2 MATRIX PRINTER STAND (OPTIONAL)

The Model 72 Matrix Printer has had modifications to the paper feed guides (see Section 5.3.4) which permit the paper to be fed to the printer from the bottom front. The earlier models have a top feed where paper is fed from the back. To utilize these two paperfeed systems requires two different printer stands. The two drawings for these stands are included in the mechanical drawing set in Section 8 of this manual. See Drawing Numbers D6641 (Top Feed) and D6641-200 (Bottom Feed) for assembly purposes.

2.3 UNPACKING AND PACKING PROCEDURES

2.3.1 UNPACKING

- 1) Cut the packing straps and remove the box by sliding it up and off. Refer to Figure 2-1.
- 2) Remove the plastic cover from the printer.
- 3) Remove the two 1/2" hex head bolts from top of the plywood base, one on each side of printer. This separates the plywood base and printer (still attached to plywood) from the pallet.
- 4) Place the printer and base on a table where the corners may be extended over the edges of the table.

HEX HEAD BOLT
(OPPOSITE SIDE)

- 5) Extend one corner of the plywood over the edge of the table. Remove the 1/2" shipping bolt recessed in that corner on the bottom of the plywood. Follow the same procedure to remove the shipping bolts from the other corners.
- 6) Slide the printer off the plywood onto the table.
- 7) Remove the tape securing the sides and covers of the printer.
- 8) Open the front cover and extend side covers to remove the tape from the following areas: (Refer to Figure 2-2).
 - a. Paper Tape Reader "A"
 - b. Left and Right Tractor Feed Units "B"
 - c. Print Head "C"
 - d. Left and Right Ribbon Assemblies "D"
- 9) Remove power cord and paper feed knob from jiffy bag located on top of the rear cover.
- 10) Close side covers and install knob onto the paper movement shaft.

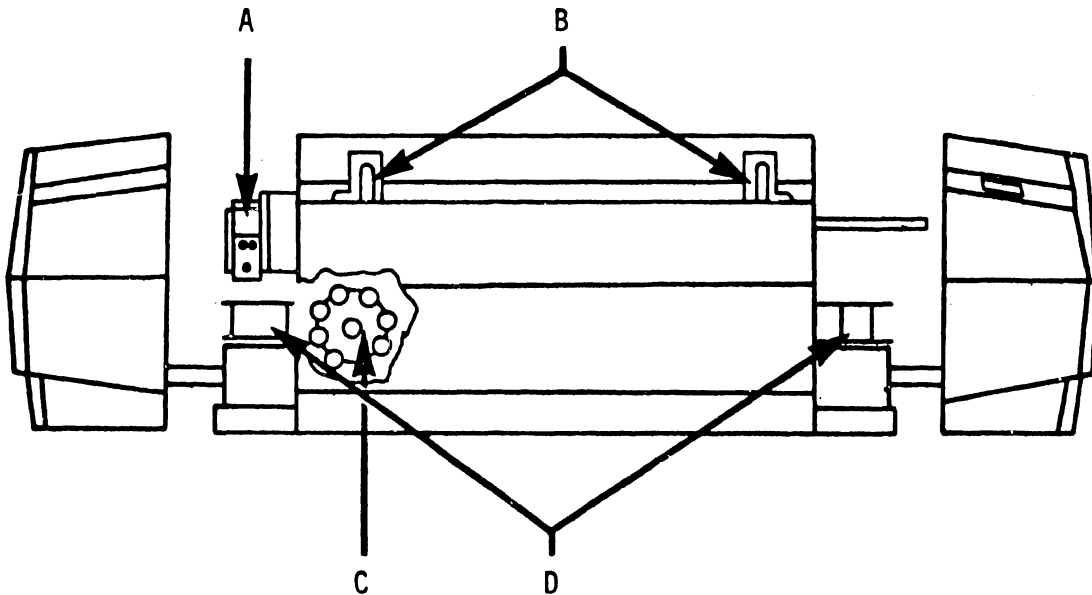

FIGURE 2-2 REMOVAL OF PACKAGING TAPE

2.3.2 PACKING

Reverse Steps 2 through 10 of the unpacking procedure, 2.3.1.

2.4 SET UP PROCEDURE

- 1) Place the printer near the rear of the table to allow the paper rack to extend over the edge as shown in Figure 2-3.

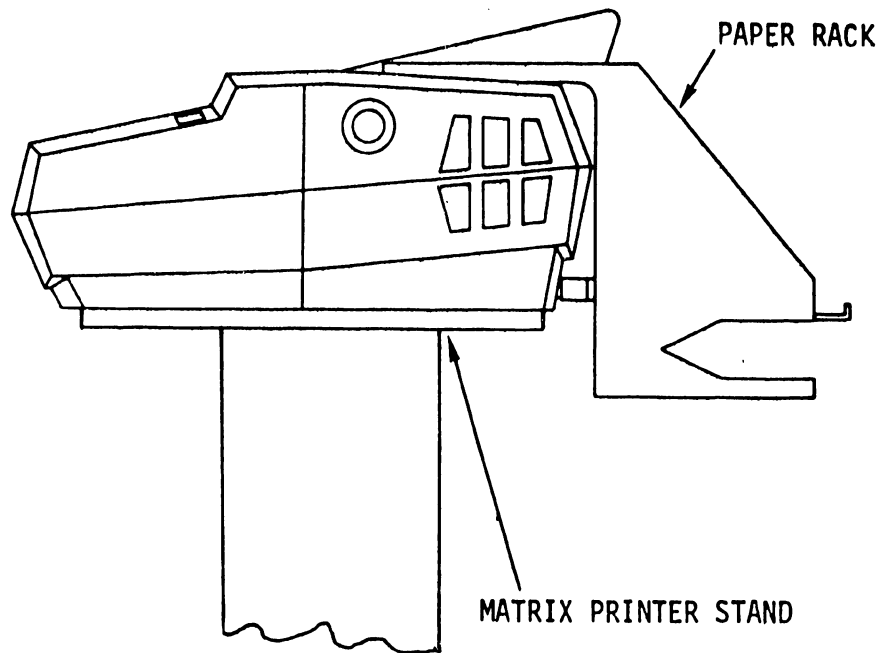

FIGURE 2-3 PRINTER WITH PAPER RACK

- 2) Attach the paper rack to the printer by inserting the slotted portion of the paper rack arms onto the support rod (support rod is shown in Figure 2-4); pull the rack to the rear as far as possible. The support rod is accessible through the gap between the rear cover and the side frames. With the arms attached to the rod, let the feet near the bottom of the rack seat around the two hex head bolts on the rear of the printer.

- 3) After the paper is loaded, the acoustic cover may be placed over the head area of the printer. First, close both side covers and latch the front cover down to hold the side covers in place. Place the bottom of the acoustic cover on the foam of the front cover. Tilt the acoustic cover toward the rear until it seats firmly on the foam of the cover supports.

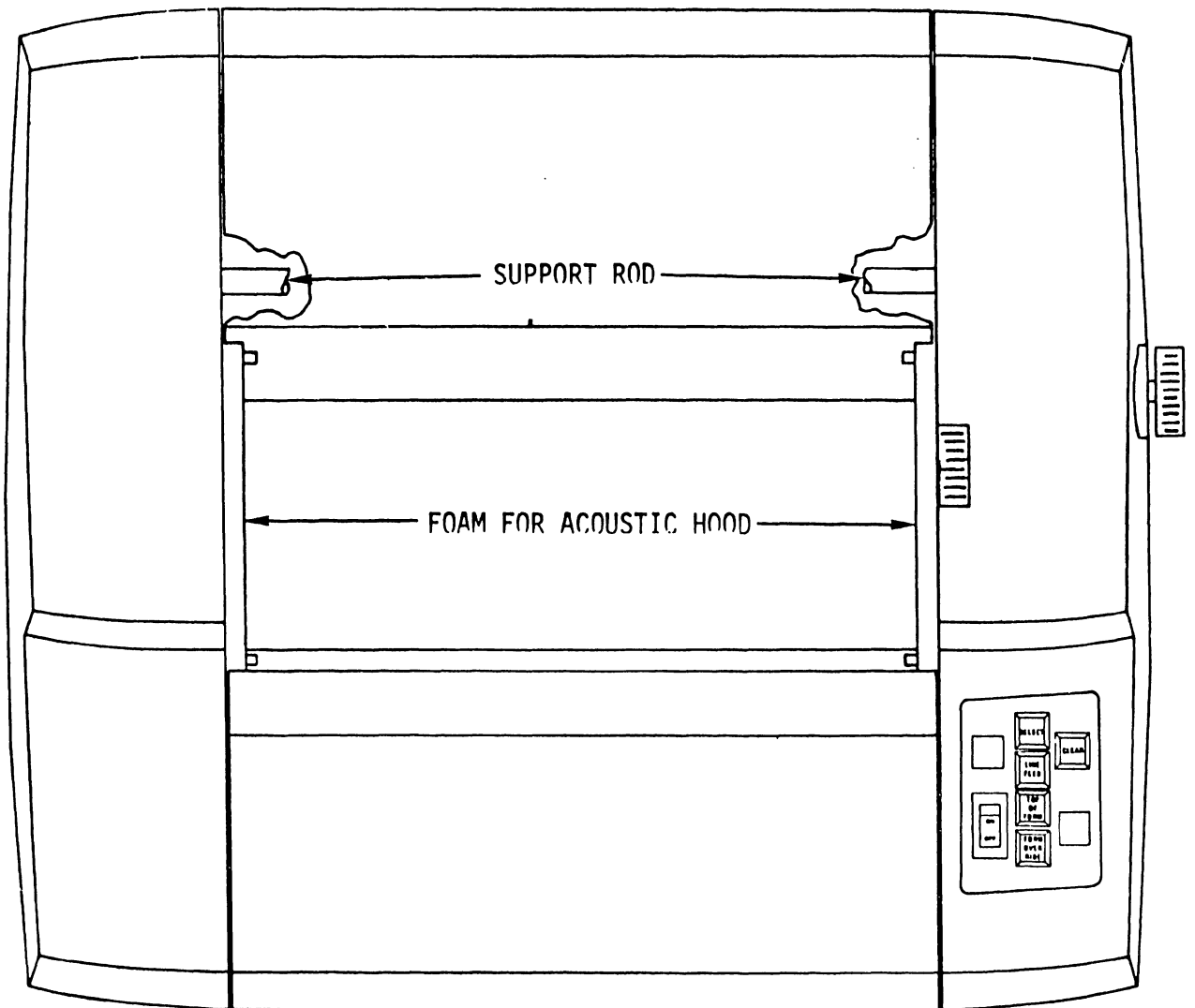

FIGURE 2-4 ACOUSTIC HOOD AND SUPPORT ROD FOR PAPER RACK

2.5 UNIT INSPECTION PROCEDURE

- 1) Lift front cover and slide open both side covers of the unit. The rear cover lies on the frame support rod and is removed simply by lifting straight up. However, it is attached to the chassis via a safety ground wire which is approximately 12" long. Complete removal of the covers requires that this wire also be detached. However, it is not necessary at this time.
- 2) With the interior completely visible, inspect all parts of the printer. Look for any unusual conditions. The following list is a suggested procedure. If any faults are found and require replacement or adjustment, refer to Section 5 of this manual.

WARNING

No power is to be applied to the printer during this inspection.

- (a) Inspect the wiring to all three reed switches prior to checking the timing fence and photocoupler pickup module. Insure that the pickup and timing fence do not make contact. Slowly move the carriage from left to right while observing the photocoupler and timing fence.
- (b) Check for damaged or loose parts. Make sure ribbon cable is not touching any part of the servo drive mechanisms.
- (c) Check for printed circuit boards loose in their connectors.
- (d) Check the cable connectors to insure they are firmly in their plugs.

2.6 OPERATOR CONTROLS AND INDICATORS (REFER TO FIGURE 2-5)

ON/OFF SWITCH: Switches power on and off.

POWER ON LAMP: Illuminates when power is on.

SELECT SWITCH: Enables input to the unit. The switch illuminates when the printer is selected.

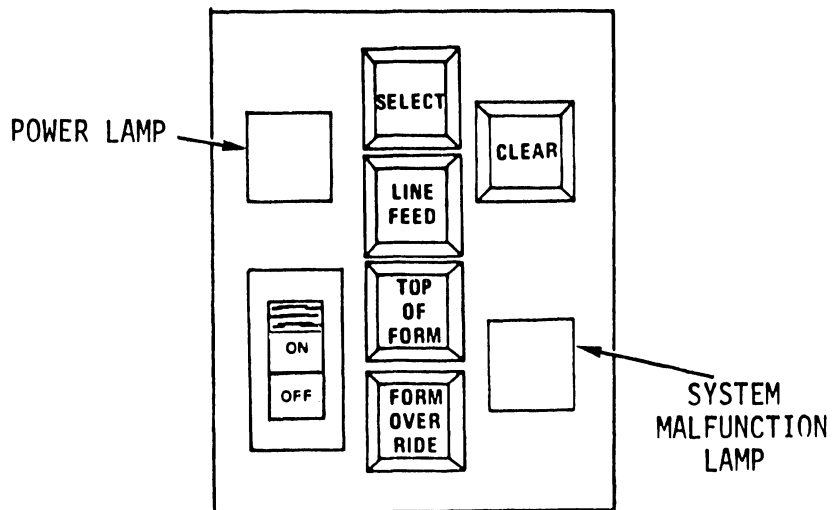

FIGURE 2-5 CONTROL PANEL

- TOP OF FORM SWITCH:** Advances paper vertically to next top of form position; switch is disabled when unit is selected.
- LINE FEED SWITCH:** Advances paper vertically one line. If held down continually, will advance paper continually. Switch is disabled when unit is selected.
- PAPER OUT SWITCH:** Opens about eight inches before paper runs completely out. At this time the switch disables the input and turns on the audio alarm for approximately 1 second.
- FORM OVERRIDE SWITCH:** Overrides the paper out switch and allows completion of the final form. The switch illuminates when the paper out switch opens.
- CLEAR SWITCH:** Clears the input buffer only when unit is deselected.
- SYSTEM MALFUNCTION LIGHT:** Illuminates when the Servo Circuit Breaker opens.
- SERVO CIRCUIT BREAKER:** Resettable breaker switch which opens when Servo Current exceeds breaker limit. See Figure 2-6.
- MAIN FUSE:** 4 amp (SB) 250 volt fuse for 115 VAC or 2 amp (SB) for 230 VAC which fuses entire unit.
- VERNIER KNOB:** Fine adjust paper left or right.
- PAPER ADVANCE KNOB:** Depressed and turned it will advance the paper manually, and will disengage the stepping motor and VFU assembly.
- FEED ADJUST KNOBS:** Adjusts sprocket wheels to paper width.

FORMS THICKNESS CONTROL: The form thickness control (Figure 2-7) will move the head closer to or further from the striker bar. When paper of different thickness is put into the unit, the head will probably have to be repositioned. Loosen the lock knob (turn CCW), turn the forms thickness knob in desired direction and retighten the lock knob.

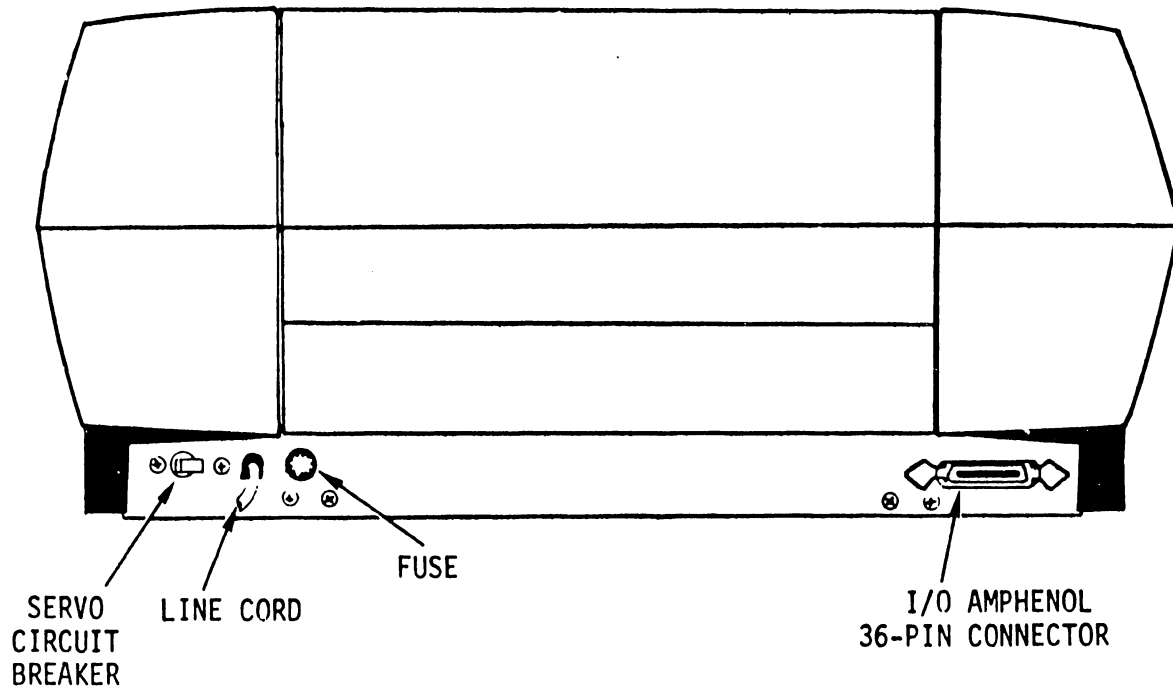

FIGURE 2-6 PRINTER (REAR VIEW)

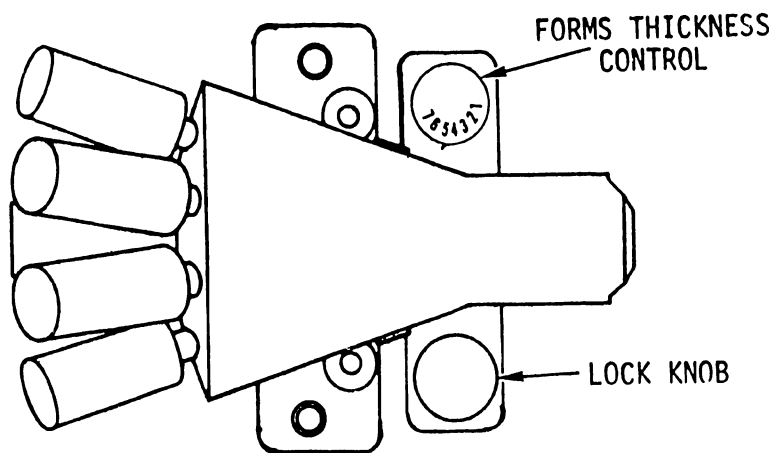

FIGURE 2-7 FORMS THICKNESS CONTROL

2.7 DYNAMIC CHECKOUT

- 1) Connect power cord to 115 or 230 volt outlet as specified. Insure that unit has the proper input.
- 2) Connect I/O cable to I/O connector on rear of unit and connector of control card 7079 or 7042 in CPU.
- 3) Turn power on and select the unit.
- 4) Insure that both cooling fans are running.
- 5) Depress the push-button MAINTENANCE switch (located on the right rear of the chassis in front of the heat sink assembly). This will cause the carriage drive assembly, ribbon and index mechanisms to operate. The carriage will advance to the right hand limit switch and then return to its original start position. During its return excursion, observe the carriage to see if it decelerates as it nears the end. The deceleration is caused by a reed switch located several inches before the carriage reaches its mechanical stop. The ribbon mechanism should advance each time the push-button is depressed. The ribbon reverse actuators should be tested by alternately pushing one or the other during carriage movement to see if ribbon travel reverses.
- 6) Load paper.
 - (a) Loosen lock knobs of pin feed sprockets.
 - (b) Slide paper into paper slot on the top of the machine. Push it through until it reaches the sprocket covers. Fit the feed holes of the paper into the pins of the sprocket wheels and close the cover and retighten the lock knobs.
 - (c) Adjust paper horizontally, using horizontal vernier adjust knob.
- 7) Run diagnostic test.

SECTION

3

OPERA-

TION

SECTION 3
OPERATION

3.1 VERTICAL FORMAT UNIT

The Vertical Format Unit (VFU) is a three (3) channel tape reader which reads a standard 1" wide, 8-channel black opaque paper or mylar tape. Because the operation of the tape reader is dependent on the switching of light via punched holes in the tape, the use of any transparent tapes could result in trouble.

The VFU is linked directly to the stepper motor which advances the line feed for both the paper by one line and the paper tape by one sprocket hole. This linkage produces six (6) lines per inch. On a standard VFU paper tape shipped with the printer, vertical tab holes are spaced six sprocket holes apart (corresponding to a 1" tab) and top of form holes spaced sixty-six (66) sprocket holes apart (corresponding to an eleven inch (11") form).

If it is desired to use a shorter or longer form, then a new paper tape must be punched to change the top of form position on the tape.

Each *vertical tab* function will advance the tape to the next hole on channel five of the paper tape.

Each *top of form* function will advance the tape to the next hole on channel seven of the paper tape.

The *end of document* feature unlike the others is nonprogrammable. It utilizes channel two of the format unit. When a hole is sensed in channel two it will create a top of form function causing the paper to advance to the next hole in channel seven. If this function is undesired, punch a tape with no holes in channel two.

A format tape may be punched using a Teletype[®]. Figure 3-1 illustrates a typical tape and a chart with characters or functions on a Teletype which may be used to punch the selected holes. Format tapes will vary in length with paper form sizes.

[®] Registered Trademark, Teletype Corporation

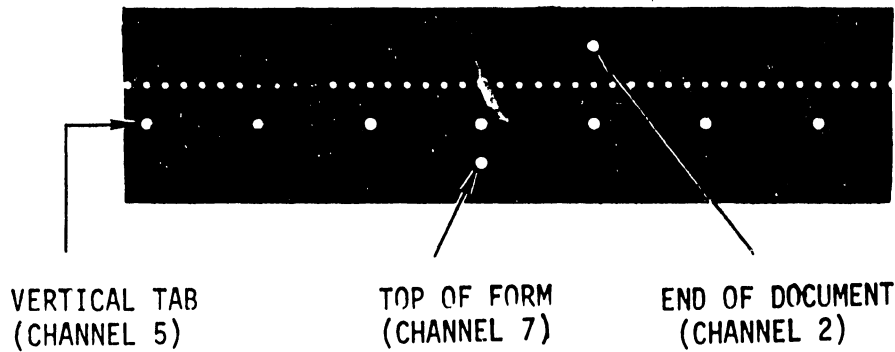

FIGURE 3-1 VERTICAL FORMAT TAPE

TYPICAL FORMAT TAPE

<u>FUNCTION DESIRED</u>	<u>CHARACTER OR FUNCTION ON TELETYPE WHICH CORRESPONDS</u>
VERTICAL TAB	CONTROL P
END OF DOCUMENT	CONTROL B
TOP OF FORM	SHIFT P
SIMULTANEOUS VERTICAL TAB AND TOP OF FORM	P
SIMULTANEOUS END OF DOCUMENT AND VERTICAL TAB	CONTROL R
SPACING BETWEEN FUNCTIONS	CONTROL SHIFT P

NOTE:

Holes punched anywhere other than channels 2, 5, and 7 are ignored by the VFU.

To splice prepared format tape, cut a piece of 1" black opaque paper tape at least 15" long. (This length will provide two *top-of-form* functions.) Determine exactly where the tape is to be spliced by counting sprocket holes and vertical tab holes. Overlap the tape ends, mark the tape accurately, cut the surplus tape square across so the new ends butt evenly to the same sprocket hole. Trim as necessary and then splice the ends using splicing squares Part #660-0176 on both sides of tape to prevent catching and breaking of splice (see Figure 3-2).

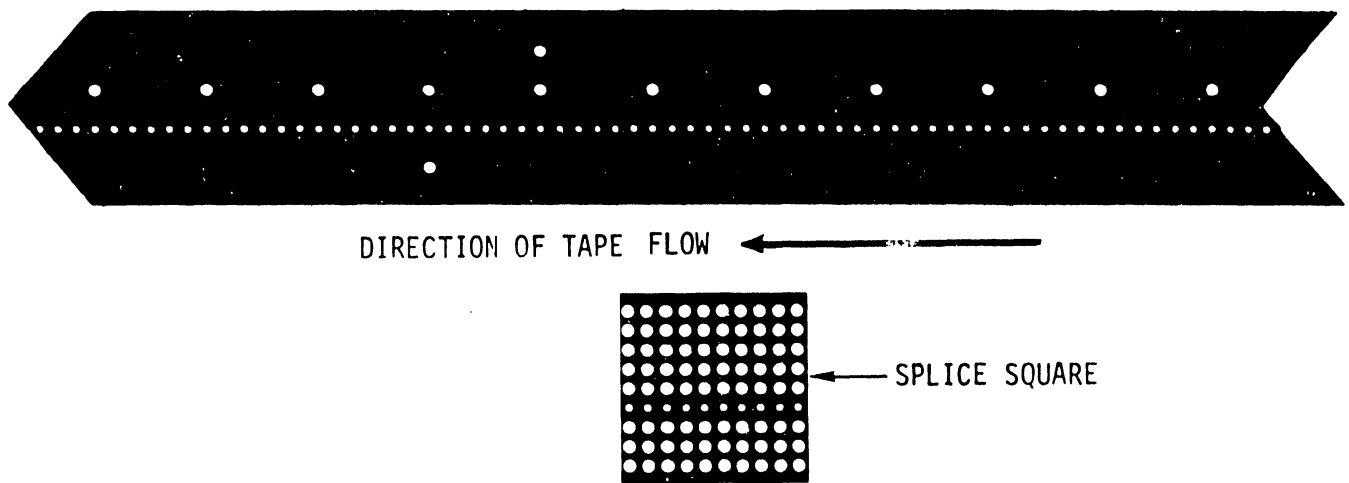

FIGURE 3-2 TAPE FLOW AND SPLICING SQUARE

To replace the Vertical Format Tape, open the front cover of the printer and push open the left hand cover to gain access to the tape reader. Lift upper reader cover (Figure 3-3) and install tape in tray provided, ensuring that the sprocket teeth protrude through the paper tape. Close reader cover.

NOTE:

It is important that the tape proceed through the tape reader in the up direction with the channel holes punched as shown in Figure 3-2. If the paper tape loop is turned inside out inadvertently the paper feed will not work properly.

The format tape guide has three posts on it. These posts allow different size tapes to be used in the reader. The length of the tape is directly related to the size of the paper forms and the number of lines printed on the form.

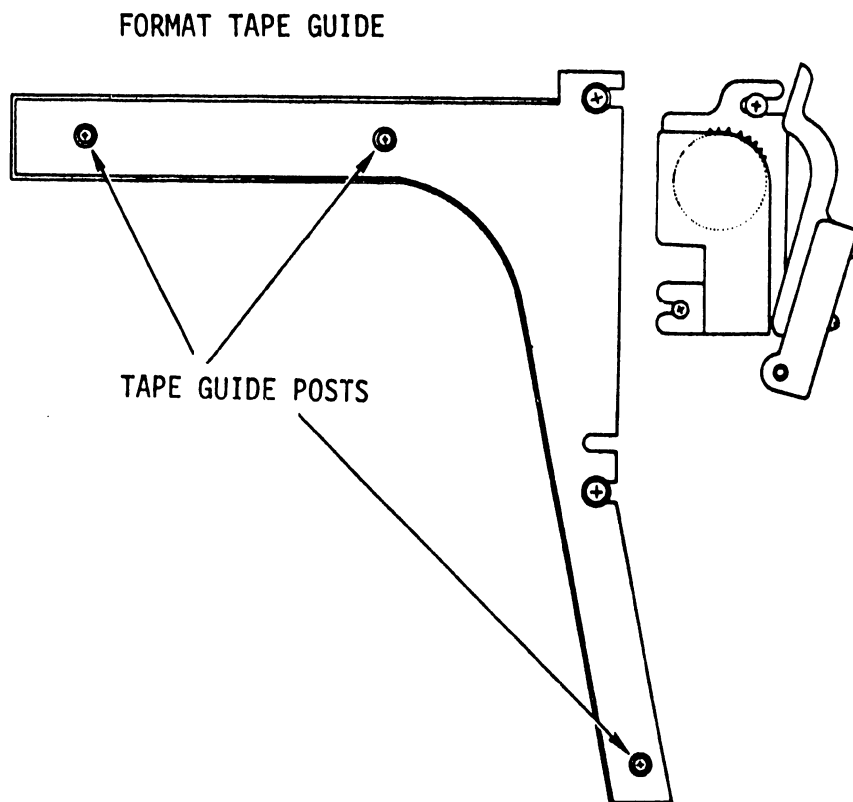

FIGURE 3-3 FORMAT TAPE GUIDE

3.2 RIBBON REMOVAL AND REPLACEMENT (FIGURE 3-4)

3.2.1 REMOVAL

- 1) Lift open the front cover; slide out the left and right sides.
- 2) Move the head as far from the paper as possible using penetration knob.
- 3) Pull the left and right ribbon spools vertically until they are completely off their spindles.
- 4) Remove the ribbon from around the ribbon tension rollers, ribbon guides and reverse actuators.

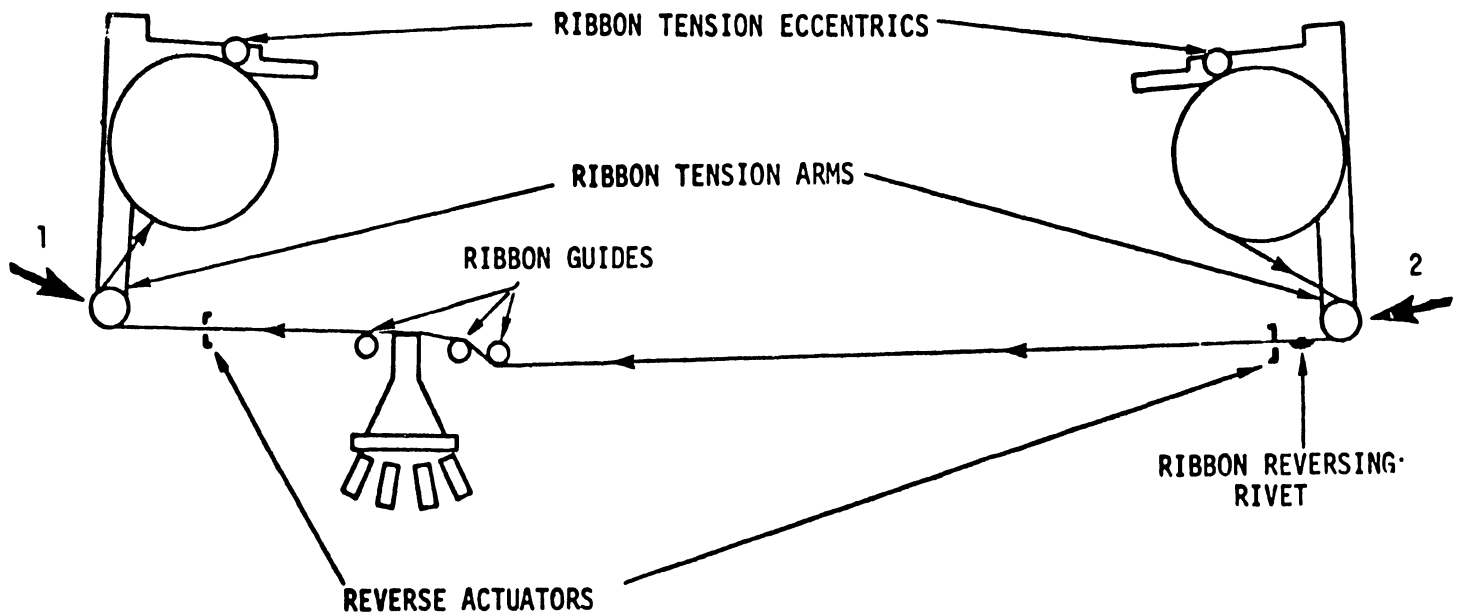

FIGURE 3-4 RIBBON REMOVAL AND REPLACEMENT

3.2.2 REPLACEMENT

- 1) Push the right ribbon tension arm at point 2. Place the empty spool on the spindle. Note the direction which the ribbon leaves the spool.
- 2) Wind the ribbon around the ribbon tension roller through the ribbon reverse actuators and guides. The ribbon reversing rivet should be to the right of the right ribbon reverse actuator.
- 3) Push the left ribbon tension arm as arrow 1 indicates and place the full spool on its spindle.
- 4) Move the head back to its original position and slide the sides back and close the front cover.

3.3 2200 OPERATION

3.3.1 DEVICE ADDRESS CODES

A three character device code, HEX *XYZ*, is assigned to each peripheral that is connected to the 2200 CPU. The first character, *X*, is the device type and the next two characters, *YZ*, are the device address.

There are three device types for the 2221W:

- 1) HEX X = 0: This device type addresses devices that do not index when a carriage return is executed; the 2200 automatically adds an index to the device. Since the 2221W generates an index with a carriage return, the output of the 2221W will be double spaced if a 0 is used.
- 2) HEX X = 2: This device type addresses devices that generate an index with a carriage return. The output of the 2221W will be single spaced if a 2 is used.
- 3) HEX X = 4: The SELECT statement specifies the maximum line length on the line printer. When the number of characters equals the specified line length, a carriage return is executed. Choosing device codes 415 or 416, however, suppresses this feature by not executing a carriage return when the number of characters equals the line length. The carriage return is not executed until the carriage return command is given or the buffer on the 2221W is filled. This gives a more interesting double spaced output when used to list program steps. Each individual statement longer than 132 characters will be single spaced, while the space between statements will be double spaced. Samples of printouts can be seen in Diagnostic Section 6.2.

There are two device address codes for the 2221W:

- 1) HEX YY = 15: This is the address normally used when one high speed printer is connected into a system. If two printers are connected in a system, code 15 addresses the first printer.
- 2) HEX YY = 16: This addresses the second printer connected to a 2200 system.

3.3.2 SELECT STATEMENTS

There are three select statements which select the 2221W for distinct types of output: SELECT PRINT; SELECT LIST; and SELECT CO.

NOTE:

In this Manual, the symbol \emptyset is equivalent to the numeral zero.

(a) SELECT PRINT 215

The above statement selects the 2221W with the device address code 215 for output resulting from the execution of PRINT or PRINTUSING statements.

EXAMPLE:

Insure that all units are on, the 2221W selected.
Key the following program:

```
CLEAR
10 SELECT PRINT 215
20 PRINT "X", "LOG X"
30 FOR X = 1 TO 10
40 PRINT X, LOG (X)
50 NEXT X
RUN
```

PRINTOUT:

X	LOG X
1	0
2	.6931471805597
3	1.098612288667
4	1.386294361119
5	1.609437912433
6	1.791759469227
7	1.945910149055
8	2.079441541679
9	2.197224577335
10	2.302585092994

If statement 10 was SELECT PRINT \emptyset 15, the output would be double spaced.

(b) SELECT LIST 215

The above statement selects the 2221W with the device address code 215 for all program listings.

EXAMPLE:

To list the preceding program, key the following:

```
SELECT LIST 215
LIST
EXECUTE
```

PRINTOUT:

```
10SELECT PRINT 215
20PRINT "X".LOG X"
30FOR X=1TO 10
40PRINT X.LOG(X)
50NEXT X
```

(c) SELECT CO 215

The above statement selects the 2221W with the device address code for printing all console output. All information keyed into the 2200 system will be printed on the 2221W until any other console output device is selected.

EXAMPLE:

Key the following:

```
SELECT CO 215
EXECUTE
RESET
```

PRINTOUT:

```
READY
```

Assuming the CRT was being used, it is now deselected and the 2221W outputs all information. The printer prints a line anytime the RETURN key is depressed or as soon as the line length is exceeded. To deselect the 2221W and select the CRT, key the following:

```
SELECT CO 005  
EXECUTE
```

The CRT is now the selected device. To list the program on the CRT, enter:

```
SELECT LIST 005
```

3.3.3 LINE LENGTH

- (a) The 2221W has a maximum of 132 characters per line. When turning system power on, the line length on all devices is set for 64 characters (because of CRT line length). To make use of all 132 characters, the 2221W must be commanded in its address statement:

```
SELECT PRINT 215 (132)
```

The 132 in parenthesis indicates that 132 characters will be allowed to be printed before an automatic carriage return is given.

- (b) Any amount of characters may limit the line length:

```
SELECT PRINT 215 (25)
```

The 25 in parenthesis only allows 25 characters to be printed on a line; an automatic carriage return would be generated if this number of characters is exceeded. The remaining characters would be printed on the next line(s).

NOTE:

If a line limit of 25 characters is given for the 2221W, this limitation applies to any output device that is selected after the 2221W with no limitation specified.

(c) More than one line length may be combined in a select statement.

EXAMPLE:

```
SELECT PRINT 215 (25), LIST 215 (64), CO 215 (132)
```

3.3.4 *TAB FUNCTION*

When a print statement containing a TAB(expression is encountered, the printer will advance to the column indicated in parenthesis in the TAB(expression.

EXAMPLE:

```
10 SELECT PRINT 215 (132)
20 PRINT TAB(25); "WANG LABS"
30 STOP
RUN
```

When these statements are executed, the 2221W advances to column 25 and prints "WANG LABS".

NOTE:

If a semicolon (;) is not used after the TAB(function, the 2221W will not necessarily tab to the correct column.

3.3.5 *EXPAND FUNCTION: HEX (ØE)*

The regular characters, 10/horizontal inch, can be expanded to double their width, 5/horizontal inch, with the following statement:

PRINT HEX (ØE), "WANG LABS"

The expand function only expands one line of print. Assuming a line limit of 132 characters in the 2221W, when more than 66 characters are to be printed with the expand function, only the first 66 are printed, the 2221W performs a carriage return and all other characters are lost. If a line limit of less than 66 characters is selected, and the number of expanded characters exceeds the line length, the expanded characters are printed up to the line limit, the printer carriage returns and prints the remaining characters on the next line(s) in regular size.

EXAMPLE:

```
10 SELECT PRINT 215 (5)
20 PRINT HEX (ØE), "111222333444"
30 STOP
```

PRINTOUT:

```
1 1 1 22
22234
44
```

A line limit of 5 was given to the printer; the printer was instructed to expand the twelve numbers. The printout illustrates that:

- 1) The printer only printed five elongated characters on the first line.
- 2) When the characters are expanded, so are the columns.
- 3) The excess characters were printed on the next two lines, the second line containing only five characters and the third line the rest.

Not only does the expand function expand the characters and columns, but also the zones.

3.3.6 ZONES

The 2221W is divided into eight zones of 16 characters each and one zone of 4 characters. The zones constitute columns 0-15, 16-31, 32-47, 48-63, 64-79, 80-95, 96-111, 112-127, and 128-131 respectively.

If commas separate elements in a PRINT statement, then each element begins at the start of a new zone. If semicolons separate elements in a PRINT statement, the zoned format is ignored, and the output appears in packed format.

3.3.7 HEX FUNCTION

The HEX function is used in a BASIC program to output characters on the printer that do not appear on the standard keyboards or to output special printer control codes. The HEX function has the form:

HEX ([hh][hh]...)

where h = a hex digit 0 to 9 or a letter A to F. An even number of characters must always appear in a HEX statement; spaces are not allowed. (See the Wang BASIC Reference Manual for hexadecimal characters and codes.) HEX codes can be combined.

EXAMPLE:

```
10 SELECT PRINT 215
20 PRINT HEX(2424)
30 END
```

PRINTOUT:

\$\$

3.3.8 CONTROL CODES

The special Control Codes for the printer are:

FUNCTION	HEX CODE	DESCRIPTION
ALARM	HEX (07)	Generates an audible tone about one second in duration in the speaker at the rear of the printer.
LINE FEED	HEX (0A)	Advances paper one line.
VERTICAL TAB	HEX (0B)	Advances paper until the next hole in channel 5 of the Vertical Format Unit paper tape is reached.
FORM FEED	HEX (0C)	Advances paper until the next hole in channel 7 of the Vertical Format Unit paper tape is reached.
CARRIAGE RETURN	HEX (0D)	Causes the line of characters stored in the printer buffer to be printed. An automatic line feed occurs after the line has been printed and the print head returns to the left side of the printer carrier.
ELONGATED CHARACTER	HEX (0E)	Prints a line up to 66 characters as expanded (double width) characters.
DELETE	HEX (7F)	Clears buffer of partial line.

NOTE:

When HEX codes are combined, control codes are executed first.

See Appendix B for complete listing of hexadecimal codes.

3.4 621W, 721W AND 1222 LINE PRINTER OPTION (LPO)

For details of operation for the 621W, 721W and 1222 LPO refer to the respective Operators manuals.

SECTION

4

THEORY

OF

OPERA-

TION

SECTION 4
THEORY OF OPERATION

4.1 INTRODUCTION

This section of the manual consists of three basic parts: a mechanical section including a general description of carriage movement, paper movement, and ribbon drive; an electrical section with detailed logic description of carriage paper movement and ribbon drive; and an electrical section on detailed logic description of the 6577, 6728 and 6576 printed circuit boards.

The 6728 and 6576 boards have been modified to 7028 and 7076 respectively. These modifications were recently incorporated for the 1222 LPO *underscore* function and the differences are described briefly in paragraph 4.3.4. The new boards 7028 and 7076 are compatible with 6728 and 6576. As a result 6728 and 6576 boards are no longer in production but they can be used in all applications except 1222 LPO.

4.2 GENERAL

4.2.1 CARRIAGE MOVEMENT

A carriage assembly moves the print head across the paper. Printing is performed by selectively firing the solenoids of the print head as it moves from left to right. Synchronization of the print process and the carriage movement is provided by an optical pickup head located on the carriage. The optical pickup head moves across the timing fence which has vertical bars that interrupt the light to the phototransistor generating a video signal. This signal is used to generate a strobe for print timing.

The carriage is driven by a servo motor which results in fewer mechanical parts and quieter operation (refer to Figure 4-1). Feedback via a tachometer mechanically linked to the motor helps maintain stability and constant speed.

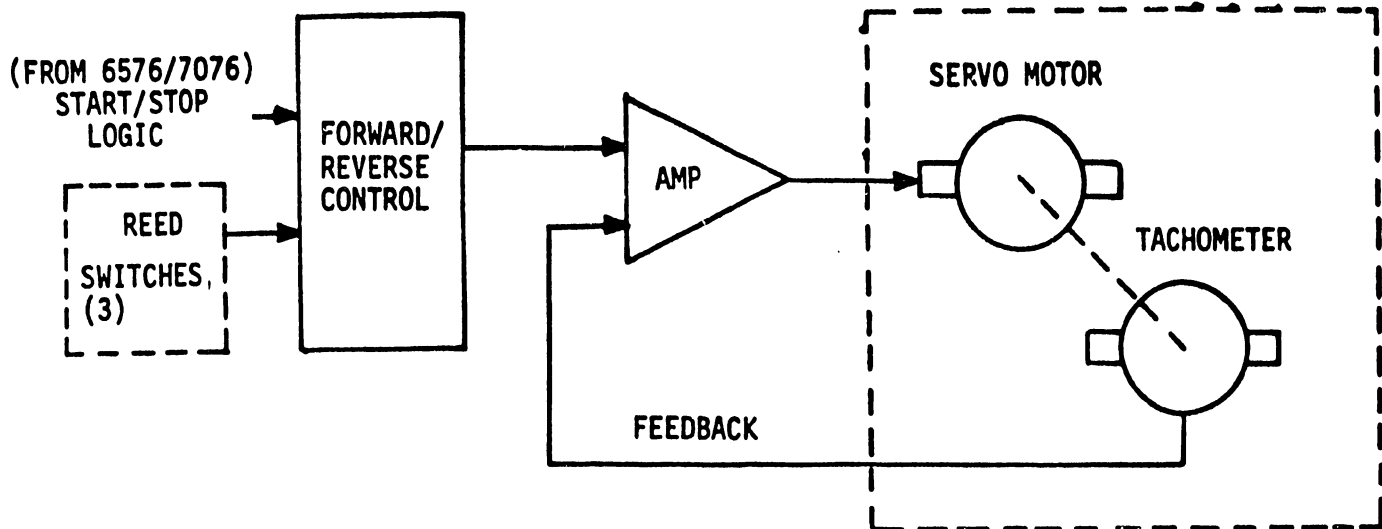

FIGURE 4-1 CARRIAGE SERVO MOTOR

There are three reed switches located on the frame of the carriage block. These switches are activated by a magnet located on the underside of the carriage. The outputs of these switches and Start/Stop logic from the 6576 board are used to control forward and reverse logic for the servo motor.

4.2.2 PAPER MOVEMENT

Paper movement is originated by three separate functions: line feed, vertical tab and form feed. Each of these functions causes paper movement by activating a stepping motor. For vertical tab and form feed, the motor will step until a hole is detected in the appropriate channel of the vertical format paper tape by the tape reader.

The Vertical Format Unit (VFU) consists of a 3 channel optical tape reader and only 3 channels 2, 5 and 7 are used. Movement of the tape in the VFU is caused by direct mechanical linkage to the gear train that feeds the paper.

LINE FEED - A line feed can be generated by any of the following three conditions:

- (a) Automatic line feed after each carriage return.
- (b) Receiving a line feed code HEX (0A) via the input as decoded by the function decoder.
- (c) Depressing the line feed key on the control panel of the 72.
(In this case, the printer must be deselected.)

VERTICAL TAB - A vertical tab can be generated only by receiving a vertical tab code HEX (0B).

FORM FEED - A form feed can be generated by any of the following three conditions:

- (a) Receiving a form feed code HEX (0C) at the input decoded by the function decoder.
- (b) Pressing the Top of Form key on the control panel. (Printer must be deselected.)
- (c) When an end of document hole is detected by the VFU.

4.2.3 RIBBON MOVEMENT (Figure 4-2)

Ribbon movement is accomplished with logic controlled triac driven 24 VAC gear motors, one for each direction. Only one motor is active at any one time. When an end of ribbon is detected, control is switched to the opposite motor. End of ribbon is sensed when a rivet on the ribbon catches and pulls the ribbon reverse actuator. This actuator closes a switch which toggles a flip-flop reversing the control logic.

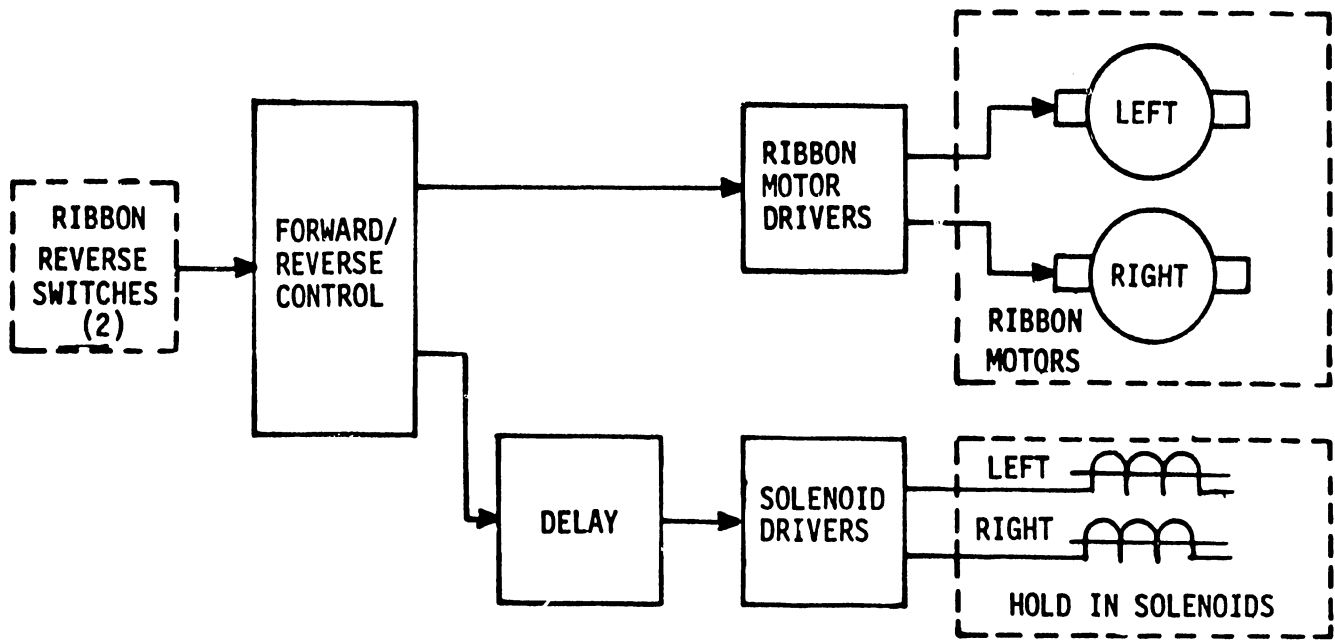

FIGURE 4-2 RIBBON DRIVE MOTOR CONTROL

Each ribbon motor assembly consists of a gear motor and a hold-in solenoid. The motor, when off, is not engaged in the gear box. However, when power is applied, motor action draws the armature up to engage the gears. When the printer is idle, the ribbon mechanism is disabled, and the motor drops from the gear box. To reduce wear on the gear motor, a hold-in solenoid is used to keep the driving motor engaged.

4.3 ELECTRICAL THEORY

4.3.1 6577 FORMAT AND PRINTING CONTROL BOARD (REFER TO DRAWING E6577)

4.3.1.1 Carriage Movement (Detailed)

When power is applied to the printer, POWER ON PRIME is generated and initializes the carriage drive and paper feed control logic. If the carriage is not at home position (SW0 closed), then a carriage return will be performed.

\overline{SFM} from the 6576 board starts the carriage moving by setting the forward flip-flop. L2-10 goes low to provide current flow through the coil of relay 1. The reed switch inside the relay closes applying +5VR to the summing junction of the servo amp. Q2 turns on to drive the base of the forward or positive motor drive power transistor. Negative feedback to the summing junction is provided by the tachometer to help maintain constant speed. Potentiometer R38 varies the speed by controlling the feedback.

Carriage return will be initiated one of two ways, \overline{CR}_b or SW2 (closed). Either one will cause L21-3 to go high and enable the outputs of the fast/slow decision flip-flop L26. If the line printed was of sufficient length to cause the carriage to move past SW1, then L26-3 will be high. A low at L21-8 will set L3-6 (fast return F/F) high and relay 2 will close. At the same time, L21-6 will go high and generate \overline{CIP} to reset the forward flip-flop, set slow return flip-flop, L4-8 high and generate a paper feed. Thus, for a fast return, both relays 1 and 2 are energized and -12V is applied through parallel resistance of R23 and R24 to the summing junction. This causes Q2 to turn off and Q6 to turn on full reversing the motor and returning the carriage.

As the carriage passes SW1 again on the return, L26-10 goes low and resets the fast return flip-flop via L27-2. Now the summing junction sees -12V through only the 470K ohm resistor. Since the larger resistance results in a larger voltage drop across the resistor, the summing junction is now less negative. Therefore, Q6 is not driven as heavily and the motor decelerates.

When the carriage returns to home position, SW0 closes and resets the slow return flip-flop. Relay 3 opens and since relays 1 and 2 are already open, no voltage is applied to the summing junction, except for the tachometer feedback. This feedback serves as a brake and the motor is stopped.

Note that RB for ribbon movement will be active whenever the forward F/F or the slow return F/F are on. Also, \overline{RS} (active low) will inhibit the start of a new line (see 6576 board) until the slow return F/F is reset and the paper feed has been completed.

If the line to be printed is short so that the carriage does not pass SW1, then the Fast/Slow Decision F/F is not set and only a slow return will be accomplished.

Carriage movement may also be originated by \overline{CFM} (maintenance switch). \overline{CFM} sets the forward F/F to move the carriage forward and SW2 originates a return. \overline{CFM} also sets WS Inhibit F/F to inhibit WS from being gated to the printing logic.

When the carriage is moving forward, \overline{CF} is used to keep the printer busy.

As the carriage moves along the timing fence, a photocoupler generates a video signal. The black marks on the fence interrupt the light between the LED (Light Emitting Diode) and phototransistor pair. The signal is amplified by an emitter follower on the 6573 finger board located on the carriage assembly.

The video signal, PE, is brought to the 6577 board at pin N₃ and applied to the inverting input of L1 operational amplifier. Q1 with L12-12 feedback changes the operational amplifier sine wave output to a rectangular wave. It is then gated at L19-8 with forward motion logic to become WS.

Potentiometer R11 is used to adjust the quiescent operating level of L1 thus changing cut-off and saturation levels of Q1 to obtain a 50% duty cycle. See Figure 4-3.

4.3.1.2 Ribbon Movement (Detailed)

When power is applied to the printer, the ribbon reverse F/F assumes an undetermined condition. RD is high when ribbon movement is active and enables gates L18-11 and L18-8. Depending on the output of the reverse F/F, one of the gates will go low and turn on transistor Q3 or Q7. When the transistor is on, +5V is applied through a 680 ohm resistor to the gate input of the triac. The triac conducts, causing the corresponding motor to operate.

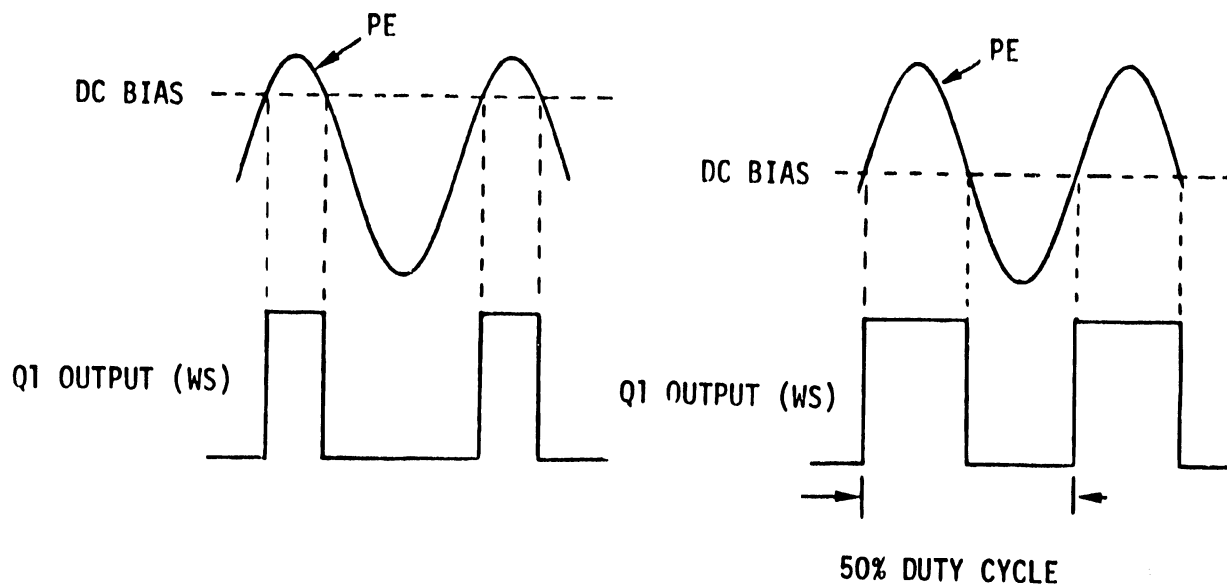

FIGURE 4-3 WINDOW STROBE (WS) ADJUSTMENT

When the ribbon approaches the end of the spool, a rivet pulls an actuator arm and closes a microswitch. This switch applies a low to the corresponding input of the ribbon reverse F/F causing the outputs to reverse. The opposite transistor now conducts and turns on its corresponding motor.

When either of the outputs of the reverse flip-flop goes high, its associated one-shot triggers. The \bar{Q} output goes low for about .3 seconds. At its trailing edge, the solenoid gate L18-6 or L18-3 goes low to turn on the solenoid driver, Q4 or Q8. With the transistor on, a current path is provided from -24V through the solenoid, 15 ohm resistor and transistor to +5V. Diodes D7 and D8 are suppression diodes for the solenoids RS1 and RS2.

4.3.1.3 Paper Movement (Detailed)

A stepping motor is used to drive the paper feed mechanism and the Vertical Format Unit (VFU). Each step of the motor accomplishes 15° rotation and there are 8 steps for each line feed. The motor utilizes a two-phase drive provided by L13 J-K flip-flop. It is called two-phase because the four windings of the motor are driven two at a time. See Figure 4-4.

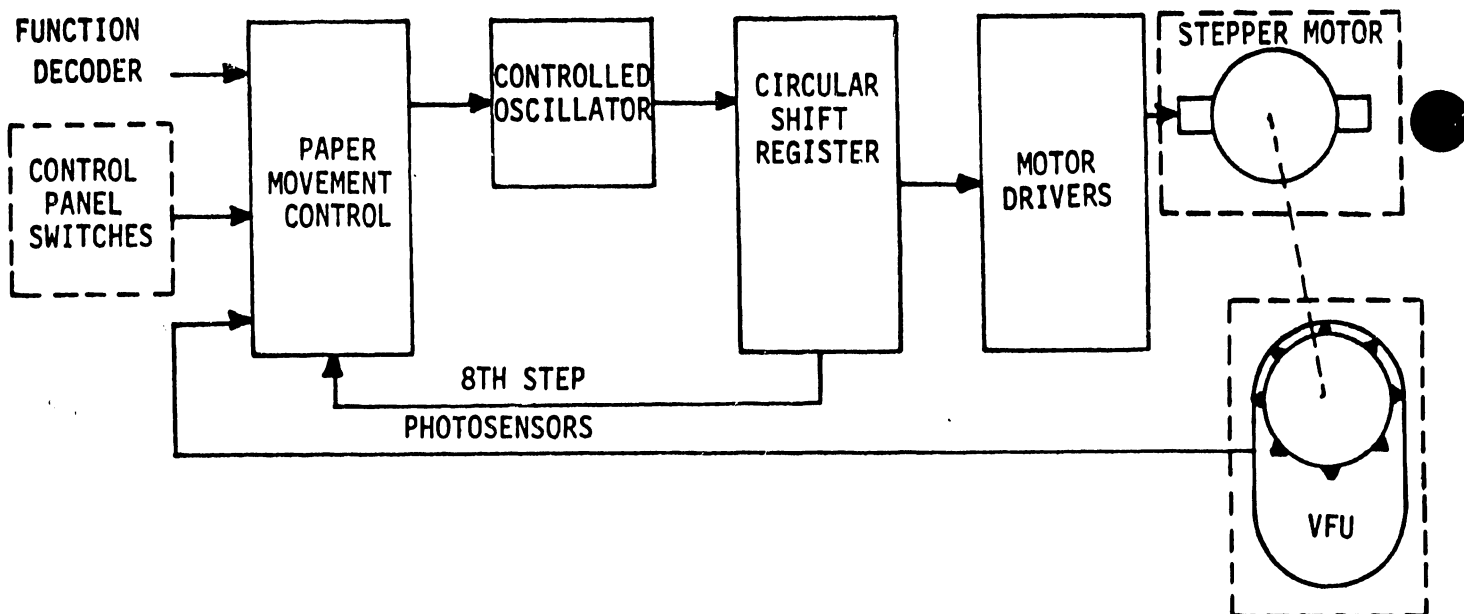

FIGURE 4-4 STEPPER MOTOR CONTROL FOR PAPER MOVEMENT

L7 is a resettable astable oscillator whose output is used to clock the two-phase drive circuit. For each cycle of L7, a step of 15° is performed.

All conditions causing paper movement such as $\overline{\text{LFM}}$, $\overline{\text{LFP}}$, etc., set the paper feed flip-flop L16-6 high. This high releases the oscillator reset line allowing it to free run. At the same time L16-8 goes low releasing the clear inputs of the two-phase drive J-K flip-flop. Since Power On Prime resets the first step F/F, L15-6 high, and both $\overline{\text{Q}}$ outputs of L13 are high, L20-4 will be low. This effectively places C22 in parallel with C23 timing capacitor. This condition exists only for the first step when L13-12 goes high and sets the first step F/F. Therefore, the first cycle of L7 is longer to extend the first step pulse AY. This is necessary to overcome the inertia of the stationary motor.

L13 circuit can provide only four combinations for stepping. For a line feed it is therefore necessary to repeat the sequence to obtain eight steps. L11-13 J-K flip-flop is used to indicate to the logic whether the motor has stepped four or eight times. On the eighth step, conditions will be such that the next cycle of L7 will generate $\overline{\text{LFE}}$. See Figure 4-5. $\overline{\text{LFE}}$ is a 15 μsec low pulse and is used to reset the paper feed flip-flop. Reset input of L7 oscillator goes low and the oscillator stops.

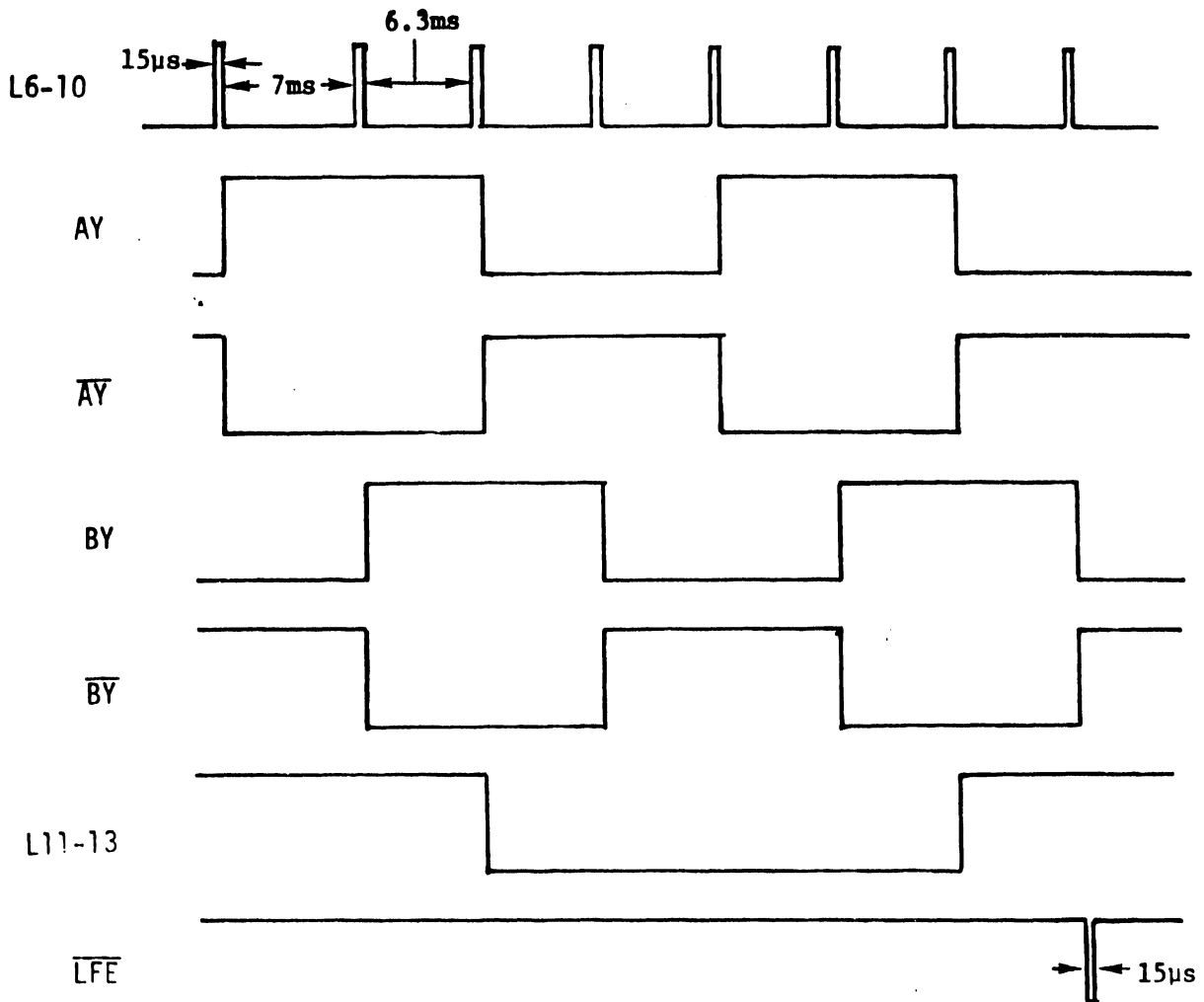

FIGURE 4-5 STEPPING MOTOR CONTROL PULSES

It should be noted that while the paper feed flip-flop is set, L16-8 causes \overline{PF} to be low and activate the busy circuit. This low will also turn on Q5 transistor. This serves to increase the potential between the common terminal and phases of the motor when stepping. See Power Circuit Dwg. E6635-999 in Section 7.

When idle, transistors Q12 and Q13 are on, making the collectors effectively +0V. The MJ 2500, Q14, is cut off so that the only potential at the common terminal of the motor is the +9V through D24. Some current flow through the coils is necessary to hold the motor in position since the motor is a variable reluctance type stepping motor.

When stepping, Q14 is turned on by Q5 of the 6577 board. The common terminal of the motor now has a potential of +18V through Q14 and D23. This provides twice the current to the coils for stepping.

Diodes D19 through D22 serve as a power return to shunt the counter EMF generated when the coils of the motor collapse. They also protect the driver transistors from damaging reverse transients.

The paper feed flip-flop L16-6 can be set by applying a low at either L16-3 or L16-4. \overline{LFM} is NANDed with \overline{SL} and \overline{LFD} to set L15-12 high. \overline{CIP} will cause L15-12 to go high as well. \overline{LFP} or $\overline{CR_d}$ with SLCTR will also cause L15-12 to be high. Whenever L15-12 is high the paper feed flip-flop is set.

If the form feed flip-flop and/or vertical tab flip-flop are set, then L28-3 will be high and hold L16-4 low. As long as these flip-flops remain set, \overline{LFE} cannot reset the paper feed flip-flop.

The form feed flip-flop can be set by any of the following:

\overline{FFP} , \overline{FFM} with \overline{SL} or PEPE at \overline{LFE} time.

The form feed flip-flop is reset when a hole is detected in channel 7 of the VFU tape. FFPE goes high generating a pulse at L24-6.

The vertical tab flip-flop is set by pulse \overline{VTP} . It is reset when a hole is detected in the VFU tape, (channel 5), by VTPE at \overline{LFE} time.

\overline{FT} is used to keep printer busy when either form feed or vertical tab are active.

J-K flip-flop L11-8 provides self-alignment of the paper with respect to the VFU. It insures that the eighth step count, \overline{LFE} occurs near the center of the form feed punched hole (See Figure 4-6). On the leading edge of FFPE, L24-6 fires and clocks L11-8 low to clear L11-13. A maximum of four steps can occur before \overline{LFE} resets the logic and stops the motor.

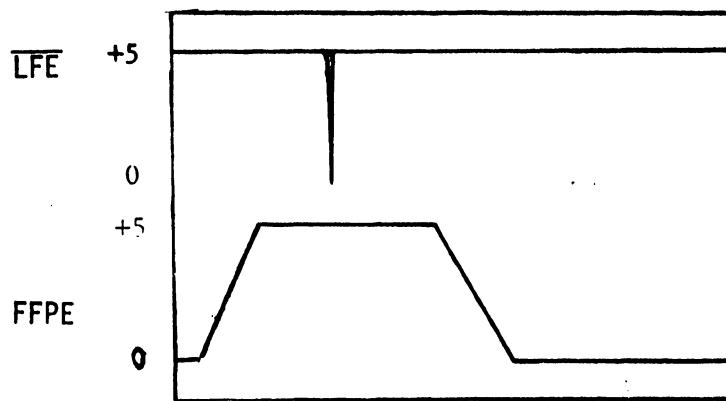

FIGURE 4-6 ALIGNMENT OF TAPE FORMAT AND
LINE FEED ENABLE

SLCTR, L30, flip-flop provides the logic with a shift register empty status. If there have been no characters shifted into the 132 bit register, SLCTR will be high. Upon receiving a CR code as the first character of a line \overline{CR}_d goes low and generates a line feed. This feature allows the operator to obtain a line feed by sending just a CR code. \overline{PS} is a low going pulse occurring only when a printable character is shifted into the shift register storage. It resets SLCTR low to indicate that the shift register is not empty and a line is to be printed before executing a line feed. The line feed will then be originated by \overline{CIP} .

4.3.2 6728 MEMORY AND REGULATOR BOARD

4.3.2.1 6728 General

The 6728 board can be divided into the following basic blocks (See Figure 4-7).

1. Column Counter
2. Character Generator ROM
3. Output Latch
4. Output Gates
5. Pulse Generators (PGs)

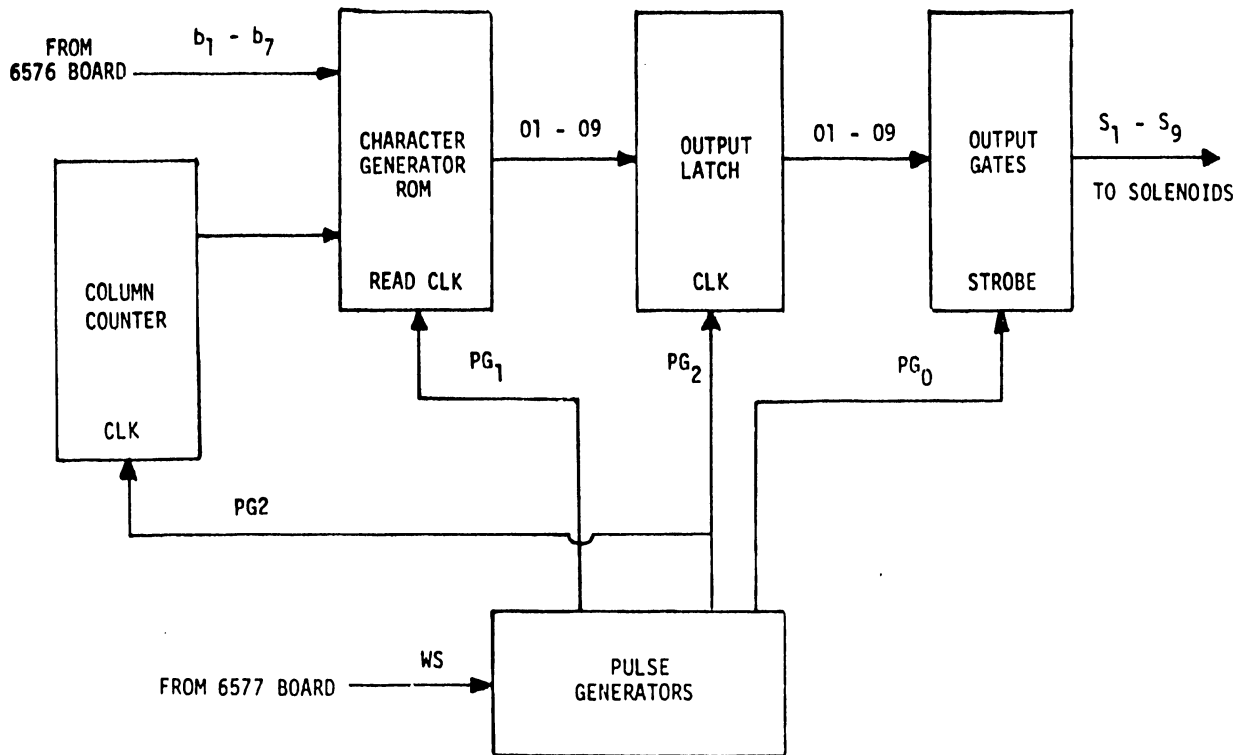

FIGURE 4-7 BLOCK DIAGRAM OF 6728/7028 BOARD

During a print operation, a character is shifted out of the 132 bit shift registers of the 6576 board. The 7 bits, ($b_1 - b_7$), are used to address the character generator. The column counter also serves to address the ROM and select the column of the character matrix. The dot pattern of the character is clocked into the output latch and is sent to the solenoid drivers at the proper time by the output gates.

All timing for this operation is generated from WS. The sequence is as follows. PG_0 strobes output to solenoids. PG_1 then provides a Read pulse for the ROM. At PG_2 time the ROM outputs 01 - 09 are clocked into the output latch. Also, at PG_2 time the column counter is incremented. This process is repeated for each leading and trailing edge of WS. There are five WS periods for each nonexpanded character printed.

4.3.2.2 6728 Logic Description (Refer to drawing E6728)

During any prime routine, a low going \overline{CLR} pulse from the 6576 board is wired into the 6728 board at pin 2₂ to initialize column counter L26 and flip-flops L12 and L17.

Bits b_1 through b_7 , from the 132 bit shift register on the 6576 board, address the character generator ROMs L20, L21 and L22. Bits b_6 and b_7 are decoded to select one of the three ROMs to be read. For characters whose codes range from HEX (20) to HEX (3F), L22 is addressed. L21 contains characters in the range of HEX (40) to HEX (5F) and L20 contains characters whose codes range from HEX (60) to HEX (7F). Only one ROM is read at a time.

Column counter L26 is incremented eleven times for each character. The eleventh count, however, is not used because the counter resets immediately following the eleventh count. The outputs of the ROMs are clocked to shift registers and strobed to the solenoid drivers. The leading and trailing edges of WS are used to generate pulses for reading the ROMs and to fire the solenoids.

4.3.2.3 6728 Sequence of Operations

Column counter L26, flip-flops L12 and L17 are reset during power-up and at the end of every line printed. At the beginning of a new line, the following events occur.

A. \overline{SFM} , a negative going pulse of about 12 μ sec causes the carriage to start moving forward and perform the following operations.

1. Produces Read Enable pulse \overline{AR} to read the ROM.
2. Clocks L5 outputs to latch L7.
3. Clocks ROM output to latches L5, L32 and L6-12.
4. Increments column counter to 0001_2 .

NOTE:

\overline{SFM} occurs only once each line.

B. First positive edge of WS causes the following.

1. Strokes L32 and L6-12 outputs to solenoid drivers.
2. Produces Read Enable pulse \overline{AR} .
3. Clocks L13 outputs to L14.
4. Clocks ROM output to latches L13, L23 and L6-9.
5. Increments column counter to 0010_2 . Clocks L17-12 high.

C. First negative edge of WS causes the following:

1. Strobes L23 and L6-9 outputs to solenoid drivers.
2. Produces \overline{AR} pulse.
3. Clocks L5 outputs to L7.
4. Clocks ROM output to L5, L32 and L6-12.
5. Increments column counter to 0011_2 .

D. Second positive edge of WS.

1. Strobes L32 and L6-12 outputs to solenoid drivers.
2. Produces \overline{AR} pulse.
3. Clocks L13 outputs to L14.
4. Clocks ROM output to latches L13, L23 and L6-9.
5. Increments column counter to 0100_2 . Clocks L17-12 low which clocks L12-9 high. (L12-9 remains high for the remainder of the line.)

E. Second negative edge of WS.

1. Strobes L23, L14 and L6-9 outputs to solenoid drivers; (L14 outputs were previously disabled by L12-9).
2. Produces \overline{AR} pulse.
3. Clocks L5 outputs to L7.
4. Clocks ROM output to L5, L32 and L6-12.
5. Increments column counter to 0101_2 .

F. Third positive edge of WS.

1. Strobes L32, L7 and L6-12 outputs to solenoid drivers (L7 outputs were previously disabled by L12-9).
2. Produces \overline{AR} pulse.
3. Clocks L13 outputs to L14.
4. Clocks ROM output to latches L13, L23 and L6-9.
5. Increments column counter 0110_2 . Clocks L17-12 (no longer relevant - L12-9 remains set).

G. Third negative edge of WS.

1. Strobes L23, L14 and L6-9 outputs to solenoid drivers.
2. Produces \overline{AR} pulse.
3. Clocks L5 outputs to L7.
4. Clocks ROM outputs to L5, L32 and L6-12.
5. Increments column counter to 0111_2 .

H. The sequence of events included in paragraphs F and G are repeated for WS fourth and fifth cycles. On the trailing edge of cycle five, column counter, L26 is incremented to 1011_2 and decoded at L18-9 to generate $\overline{SF6}$. $\overline{SF6}$ resets L26 to 0000_2 and shifts next character to the output of the 132 bit register on the 6576 board.

The process described in paragraphs F, G and H are repeated for each remaining character of the line. See Figure 4-8.

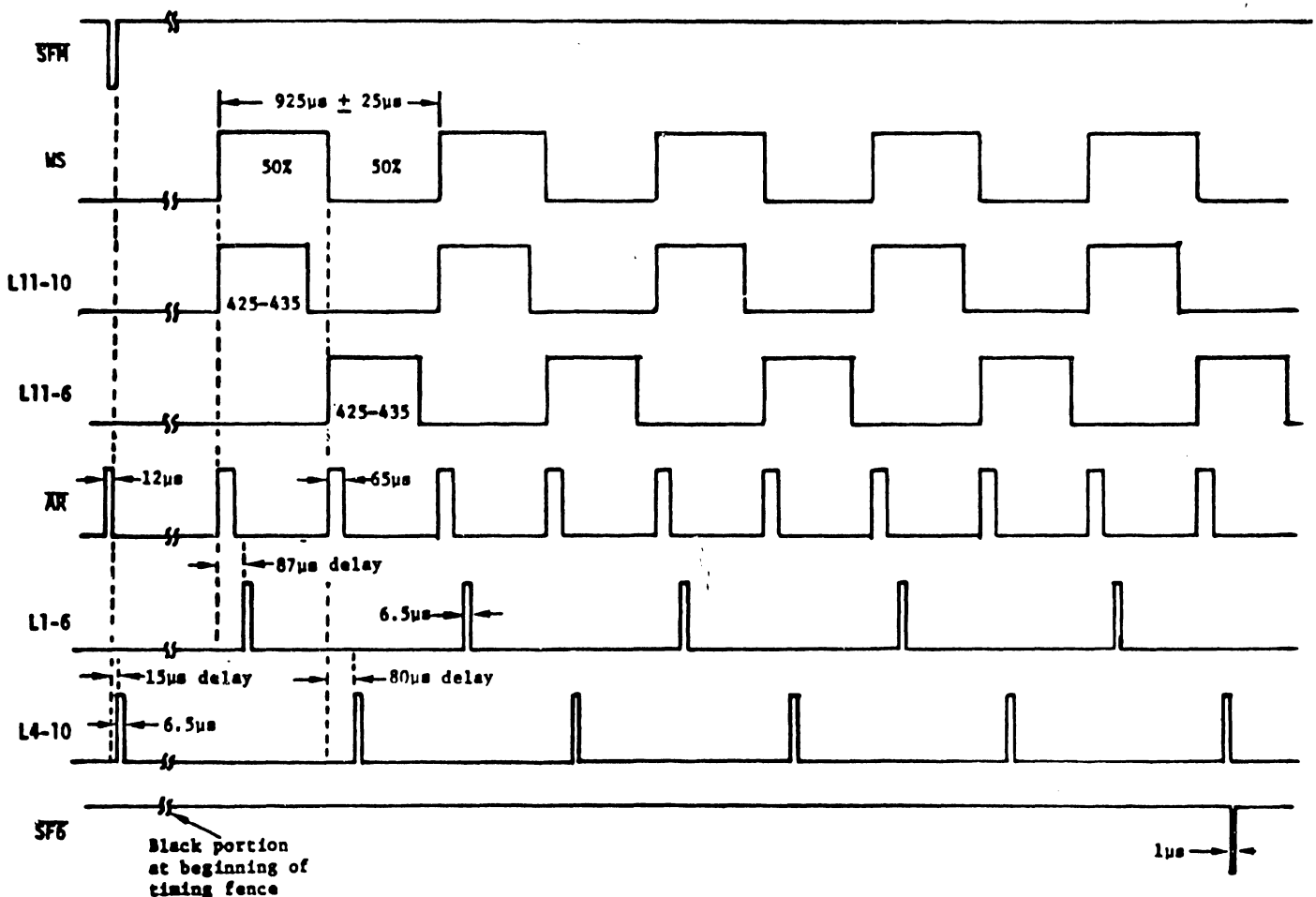

FIGURE 4-8 TIMING DIAGRAM FOR ACTIVATING PRINT SOLENOID STROBES AND COLUMN COUNTER

To begin the print cycle, \overline{SFM} a low going pulse of about 12 μsec forward biases D5 and gives a positive pulse \overline{AR} at L10-8. This is the read strobe for the ROMs. D7 is also forward biased holding L4-2 high. Since C3 is already partially charged at this time, the one-shot does not fire. At the trailing edge of \overline{SFM} , L4-2 goes low and one-shot L4-12 fires. Its trailing edge fires L4-10 for a positive pulse of about 6.5 μsec . This pulse is used to clock "01" through "08" outputs of the ROM to the shift registers L5 and L32, and to clock output 09 of ROM to Q1 side of L6. It also increments L26 column counter through L2-6 and L3-10. The shift registers are used as latches to temporarily store the ROM outputs.

When column counter L26 is at "0000" all "ones" are read from the ROM to the shift register. The result is that the solenoids are not fired. This is true for all characters with only one exception, lower case letter M (see character set in Appendix D).

As the head assembly moves forward, a signal is generated by the timing fence and photocoupler mounted on the head assembly. This signal is reshaped and gated to the 6728 board as WS by logic on the 6577 board. When WS is not present, pin L₃ of the 6728 board is low. The leading edge of WS therefore, will be positive and L10-12 goes low firing one-shot L11-10. L11-9 goes low for approximately 430 μsec which enables gates L33 and L2-3. L11-10 and L12-9 are ANDed by diodes D11 and D12 at the input of L18-13. L12-9 is still low so that L18-13 is clamped low. The result is that the even numbered solenoids cannot be fired at this time because L18-12 will be high inhibiting gate L8.

On the same positive leading edge of WS, L3-4 goes high firing one-shot L1-2 to be gated at L2-13 to D6 generating a Read pulse \overline{AR} for the ROM. One-shots L1-4 and L1-6 provide a 6.5 μs pulse delayed by 22 μs to clock L17 flip-flop. One-shot L1-6 is gated at L2-5 to increment the column counter L26 and is also tied to clock inputs of L13, L23 and Q2 side of L6.

On the trailing edge of WS, L11-6 is fired. Since this output is gated with L12-9, it cannot fire the even solenoids at this time. L11-7 goes low and enables gates L2-8 and L24 pins 3, 5, 8 and 11. Also, at the trailing edge of WS, L1-8 goes low firing one-shot L1-10 which through L2-11 and 13 generates a Read pulse \overline{AR} . L1-10 also goes to L4-3 to fire one-shot L4-12 and L4-10 to clock the ROM output into L5, L7, L32 and Q1 side of L6. L4-10 also goes through L2-6 and 4 to L3-11 and 10 and increments the column counter, L26.

On the second positive leading edge of WS, one-shot L1-6 clocks L17-1 for the second time. L17-12 acts as a divide by two counter so that after two clocks Q output is back low which completes the clock cycle required for L12-9. L12-9 goes high and remains high for the completion of the line. The even solenoids can now be fired.

At each WS signal, the counter, L26, is incremented for each leading and trailing edge. When L26 reaches a count of eleven, as decoded at L18-9, $\overline{SF6}$ is generated. $\overline{SF6}$ is used to clear L26 and to shift out the next character from the 6576 board.

For expanded print, input EC will be high and \overline{EC} low. This enables NAND L28-8 and disables L28-11. This action serves to clock input B of L26 by the output of L12-12 instead of by A output on L26. L12-12 divides the A output of L26 by two. This causes the column counter to count as shown in the chart below:

Input A # of Clocks	Outputs			
	D	C	B	A
0	0	0	0	0
1	0	0	0	1
2	0	0	0	0
3	0	0	0	1
4	0	0	1	0
5	0	0	1	1
6	0	0	1	0
7	0	0	1	1
8	0	1	0	0
9	0	1	0	1
10	0	1	0	0
11	0	1	0	1
12	0	1	1	0

13	0	1	1	1
14	0	1	1	0
15	0	1	1	1
16	1	0	0	0
17	1	0	0	1
18	1	0	0	0
19	1	0	0	1
20	1	0	1	0
21	0	0	0	0

To activate a print solenoid, the appropriate transistor Q11 through Q19 on the 6728 board, must be turned on. Refer to Power Circuit Dwg. E6635-999. For example, if Q16 is on, it provides +9V (SW) to the base of Q1 to switch it on. Q1 provides a path for current to flow from the +36V through load resistor R3 and the solenoid coil to +0V. Zener diode, D1, protects Q1 from high voltage transients when the coil collapses and helps to decrease the response time of the coil by providing a shunt path for counter EMF. Other solenoid circuits, Q2 through Q9, function in a similar manner. D1 through D9 are 68 volt zener diodes located on the 6704 board.

4.3.2.4 6728 Circuit Functions

L11 One-Shots - Provide strobes to fire solenoids. Adjustable pulse width determines how long the solenoids will remain energized. Should be adjusted for 425 to 435 usec.

L26 Column Counter - Provides addressing for columns of each character matrix. Is incremented by a count of one at $\overline{\text{SFM}}$ and at each leading and trailing edge of WS. Addresses ten columns for each character and resets on eleventh count.

L17-8 Flip-Flop - Is set at $\overline{\text{CLR}}$ time and remains set for duration of line. As carriage return code HEX (0D) is decoded at the output of the shift registers signifying end-of-line, $\overline{\text{CR}}_e$ is generated. $\overline{\text{CR}}_e$ clears L17-8, causing pin 8 to go high. L19-10 then goes low disabling

counter L26. L19-8 goes low to force CR code, HEX (0D) to a lower case dash (-), HEX (2D). This insures that no solenoids are fired at this time. Lower case -, as most characters, contains no output at column "0".

L12-12 Flip-Flop - Serves as a divide by two counter for "A" output of L26. Its output is gated to B input of L26 during expanded print operation.

L17-12 Flip-Flop - A divide by two counter used in conjunction with L12-9 to inhibit strobes for firing "even" solenoids. This allows erroneous data to be shifted out of L7 and L14 secondary latches at the beginning of a line.

4.3.2.5 6728 Power Supply Circuit (Refer to drawing E6635-999)

L27 and its associated circuitry form the +5V regulator. The MJ3000 transistor pair provides +5VR from the +9V supply. The +5VR output is adjusted by R82. (See paragraph 5.2 for adjusting voltages.)

L16 is the -12V regulator adjusted by R103. Q6 controls the base of the regulator transistor Q16 located on the heat sink assembly. The -24V supply provides the source for the -12VR. +12V is obtained from the +18V supply by regulator Q8.

During power up, all switched voltages are held off until the +5VR reaches a level of about +4.6V. This keeps the motors and solenoids disabled until the logic achieves control.

+5VR is brought to pin 14₁ to be monitored at the base of Q10. During power up, Q10 is held off until the +5VR reaches approximately +4.6V. At this time, Q10 turns on and the base of Q9 goes negative with respect to its emitter and it turns on, thus providing +12V at pin A₁. The output of Q9 also acts to turn on Q2 which turns on Q1 switching on the +9V. The output of Q9 also goes to Q7 to switch on the -12V. Transistors Q3 and Q4 are held off by -12V (SW). Q5 is held off by the output of Q9.

During power down, when +5V goes below +4.6 volts, the +12V (SW), -12V (SW) and +9V (SW) voltages are switched off. This action causes Q3, Q4 and Q5 to turn on and discharge the capacitors in their respective supplies.

4.3.3 6576 I/O CONTROL AND DATA STORAGE BOARD

4.3.3.1 6576 Operation - See Figure 4-9

Data bits DT1 through DT7 are received at the input buffer. At the buffer output, the seven bits are monitored to decode any functions. If a function is decoded, the control logic sets the Busy latch and executes the function. At the completion of the function, an Acknowledge pulse is sent to the external device. If the input is a printable character, then it is shifted into the 132-bit register by the control logic. An Acknowledge is sent to tell the external device that the character was received and is ready for the next input.

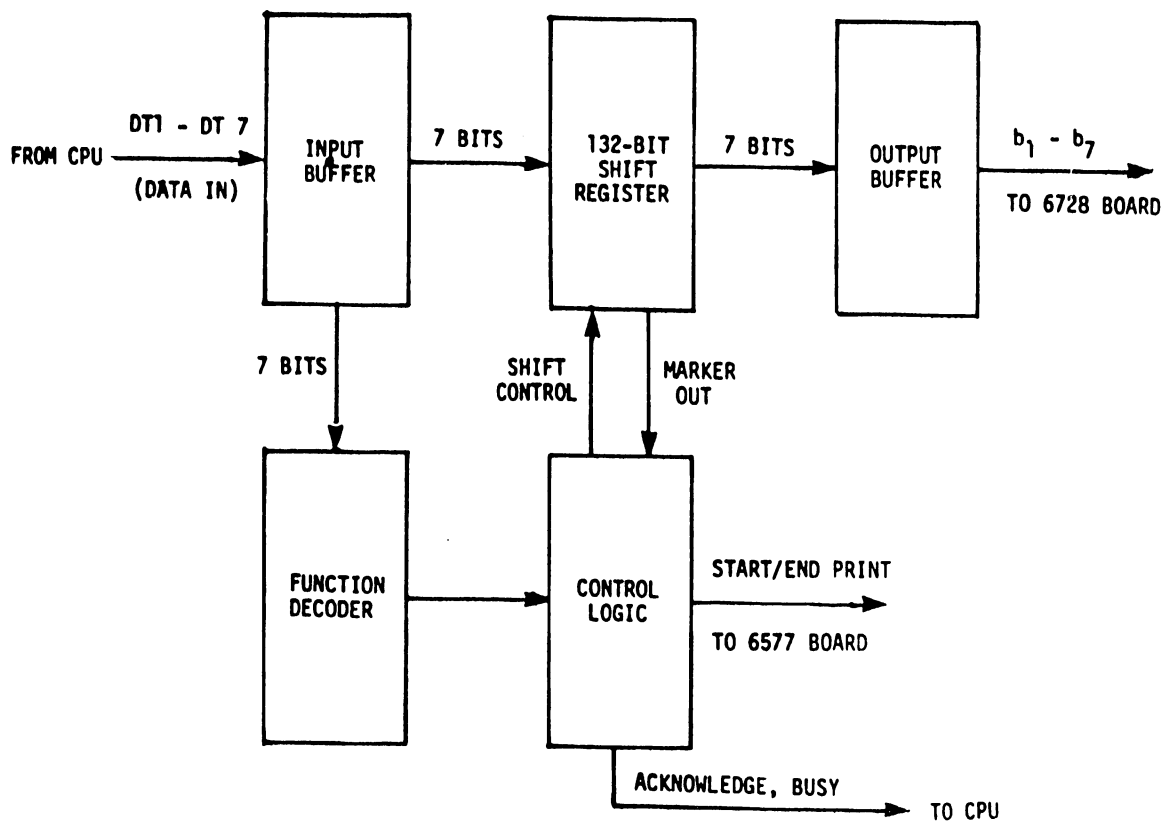

FIGURE 4-9 BLOCK DIAGRAM OF 6576/7076 BOARD

Function codes are not shifted into the 132-bit registers with the exception of carriage return. It is used during shift out to terminate printing.

Upon receiving a CR code, or detecting the marker bit at the shift register output, the print cycle is initiated. Characters are shifted out through output buffer to the 6728 board to be printed. By monitoring the shift register output, the print cycle is terminated by the control logic.

4.3.3.2 Power-On-Prime (Refer to drawing E6576)

When power is applied to the printer, C3 (18 μ f) charges through R16 (56K). This causes L7-12 to go low after C3 charges to TTL level. L7-10 is high at this time and L6-11 goes high to fire one-shot, L10-7. The duration of this one-shot is approximately 3.3 ms to activate the prime circuit. Power On Prime signal generates CLCR at Pin F₃ to initialize a latch on the 6577 board.

4.3.3.3 Other Prime Conditions

The prime circuit may also be activated by \overline{CIP} , \overline{IP} , \overline{DELP} and \overline{CLRM} . Any one going low will cause L1-8 to go high, firing L10-9 one-shot for 3.3 ms. L12-8 acts as an OR circuit as either one-shot L10-9 or L10-7 will cause L12-8 to go high for 3.3 ms.

4.3.3.4 Prime Circuit

When L12-8 goes high, L14-2 will go low to set flip-flop L8A-11 low. This low will be used to reset CR flip-flop L12-1, low. L14-2 will also clear L13-13, holding \overline{CLR} low. \overline{CLR} is used to reset EC (expanded character) flip-flop; routed to the 6728 board to initialize logic; clears MKR flip-flop L13-9; and goes to L3-2 to generate a Busy signal. It also serves to clock paper-out latch via L12-4.

The following paragraph describes the clearing and loading of a marker bit in bit position number 8 of the 132-bit shift register (print buffer). A marker bit is used for two purposes. It indicates the

position in the print buffer of the first character to be printed and indicates when the print buffer is full (contains 132 characters to be printed). In the prime routine, the marker bit is placed in the first position of the shift register after all random bits have been shifted out and replaced by zeroes.

With L13-12 low, L5-8 will be kept high enabling L12-11 to follow $\overline{\text{CLK}}$. L11-6 will follow L12-11 at $\overline{\text{CLK}}$ time firing one-shot L2-6 on each leading edge. L2-6 is used as a shift clock for the 132-bit registers. Since MK(D8) at L6-8 is low during this time, zeros will be shifted into the (D8) position of the shift registers, clearing out any Markers. The preceding conditions will exist until the 3.3ms one-shots time out. At that time, L13-12 will set on trailing edge of CLK. A marker bit, MK, will exist at this time (see Figure 4-10) and the leading edge of $\overline{\text{CLK}}$ will shift it into the first register. At the trailing edge of $\overline{\text{CLK}}$, L5-8 goes low to inhibit MK bit and also to inhibit any more shift clocks via L12-11. $\overline{\text{CLR}}$ goes back high to release the Busy circuit. The logic is now initialized, and a marker bit, MK, is in the first position of the shift register. When selected the printer is ready to receive inputs.

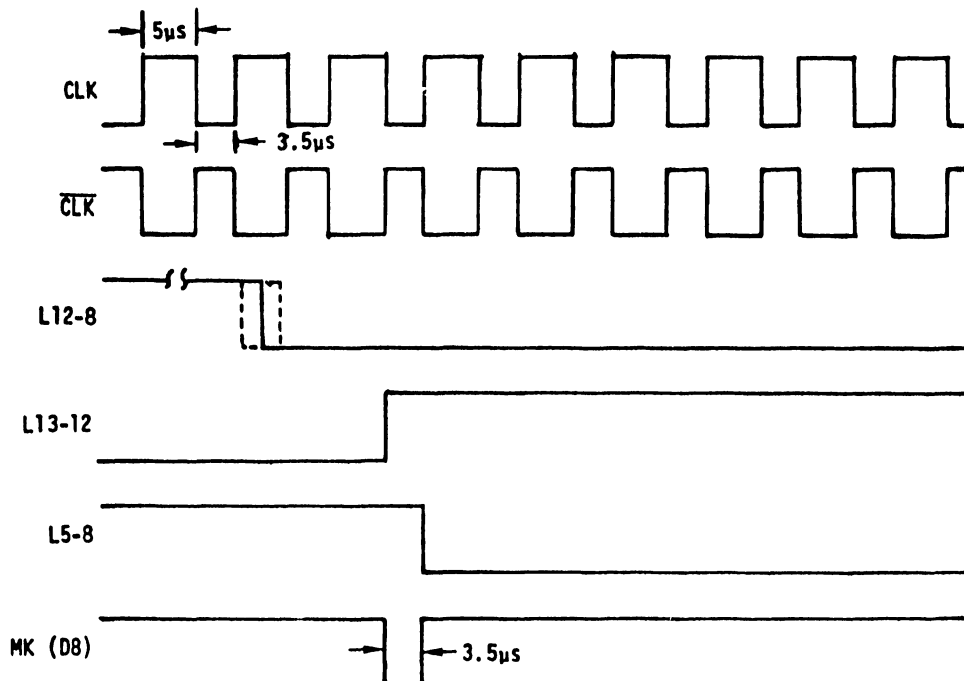

FIGURE 4-10 MARKER BIT GENERATOR

4.3.3.5 Select Circuit

Before accepting any data, the printer must be selected. This is done by depressing the select switch on the control panel.

When the switch is depressed, a low is applied to pin 11_2 causing L8A-6 to go low. Upon releasing the select switch, a low is applied at pin 11_3 and resets L8A-6 high. On the negative edge of L8A-6, one-shot L8-10 fires to clock SL latch L5-12. With SL high, the Busy circuit is released and other gates are enabled. A lamp inside the Select Key is lit and a select status bit SLCT is provided at the I/O interface. Select control, SLCTR, is gated with \overline{SL} at L27-11 for a Busy condition. Set high at the end of each print cycle, SLCTR goes low with the receipt of the first printable character. If the printer is deselected during buffer loading, then SLCTR will inhibit L27-11 from causing a Busy at this time.

The printer may be selected and deselected alternately by pressing and releasing the Select switch. Also, note that SL latch is cleared by the power-up circuit to keep the printer deselected at power-on.

4.3.3.6 Print Buffer Loading

Data bits, DT1 through DT7, are buffered and presented at the inputs of the shift registers and the function decoders. L21-8 decodes the bell function or audio alarm. L21-6 decodes the delete function. L32, a BCD-TO-DECIMAL decoder, decodes line feed, vertical tab, form feed, and carriage return. L22-6 decodes any function or character in the range of Hex (00) to Hex (1F) except for carriage return. The output, \overline{FC} , is used to inhibit the loading of functions to the shift registers and to initiate a busy condition. Note that all function decoders are gated by DSTB, and that the duration of each output will be a direct function of the pulse width of DSTB.

DSTB is used to fire $\overline{\text{AKDLY}}$ one-shot and to generate an SFK (shift clock) for the shift registers. For SFK pulse, DSTB is gated with $\overline{\text{FC}}$ at L11-8. If $\overline{\text{FC}}$ is active (low) DSTB will not get through. For printable characters, $\overline{\text{FC}}$ is high and $\overline{\text{PS}}$ is generated. $\overline{\text{PS}}$ resets L8A-11 flip-flop, resets SLCTR latch on the 6577 board low and causes output L11-6 to go high. On the low to high transition SFK one-shot is fired to shift in the character on the input lines.

$\overline{\text{AKDLY}}$ is a low for a 7 μsec duration. If the character at the input didn't cause a busy condition, then the trailing edge of $\overline{\text{AKDLY}}$ will fire the $\overline{\text{ACKLG}}$ one-shot via L29-3. If a busy condition did exist longer than 7 μsec , then $\overline{\text{ACKLG}}$ would be generated by the trailing edge of $\overline{\text{RDY/BSY}}$. $\overline{\text{ACKLG}}$ may be used to initiate the next DSTB on the sending device.

4.3.3.7 BUSY/READY Circuit

The BUSY circuit is used to indicate to the sending device that an operation is in process. It also inhibits the $\overline{\text{ACKLG}}$ pulse to allow the printer to become ready before more input is accepted.

The following conditions will cause the busy latch L39-12 to go low or busy.

1. $\overline{\text{FC}}$ - function decoded at input
2. $\overline{\text{CLR}}$ - prime circuit is active
3. Audio Alarm - 1.1 second audio alarm active
4. $\overline{\text{Cover Open}}$ - gated with SLCTR
5. $\overline{\text{SL}}$ - select status gated with SLCTR
6. $\overline{\text{PF}}$ - paper feed in process
7. $\overline{\text{FT}}$ - form-feed or vertical tab in process
8. $\overline{\text{CF}}$ - carriage forward indicating device is printing
9. $\overline{\text{MKR}}$ - buffer full condition
10. $\overline{\text{CR}}_a$ - carriage return decoded at input
11. $\overline{\text{PAPER OUT SW}}$ - paper out sensed
12. $\overline{\text{MALFUNCTION}}$ - servo circuit breaker open

\overline{PF} , \overline{CF} , \overline{FT} , \overline{CR}_a and \overline{MKR} are NORed by expandable AND gate L1-6. Any low input will cause L1-6 to go high and cause L19-4 to go low. This low is applied to D21 and NORed with other inputs by expandable NAND L3-6. Again, any low input will cause L3-6 to be high, giving a low on busy latch clear input, keeping it busy.

$\overline{MALFUNCTION}$, $\overline{PAPER-OUT}$, and \overline{BELP} are NORed by L4-8. This gate serves to generate an audio alarm by L8-4 and a busy condition by L7-2 and L3-6.

$\overline{COVER-OPEN}$, \overline{CLR} , \overline{SL} and audio alarm one-shot (L8-7) are NORed at L3-6 to obtain a busy condition.

The busy latch is set to READY on the first \overline{CLK} after the busy condition is removed.

4.3.3.8 Print Cycle

The print cycle is initiated by detecting a print buffer full condition or decoding a CR at the input.

Buffer Full Print Cycle

As each character is shifted into the buffer, the marker bit MK(D8) is shifted along ahead of the data in. When 132 printable characters have been inputted, the MK bit is sensed by MKR flip-flop L13-9. $\overline{MRK(Q)}$ goes low to set printer busy. MRK(Q) goes high to enable diode AND gate, L15-6, and fire one-shot L9A-10 to generate \overline{SFM} . \overline{SFM} sets logic on the 6577 board to start the carriage moving. As the optical sensor on the carriage assembly passes the marks on the timing fence, the character at the buffer output b1 through b7 is printed. Each time the sensor passes five marks $\overline{SF6}$ at pin N₁ goes low generating a shift clock to shift out the next character. After printing the 132nd character, the carriage magnet closes SW2 (right-most reed switch) to reverse the servo logic. \overline{CIP} from the 6577 board generates a prime condition to initialize the printer for a new line of data.

Decoded Carriage Return Print Cycle

When a CR code is received at the input and less than 131 printable characters have been shifted into the registers, \overline{CR}_d (decoded by L32-6) initiates the print cycle. Since the first character to be printed could be in any one of the 131 register positions, some means must be used to shift it to the output before carriage movement is initiated.

Upon decoding a carriage return at the input buffer, \overline{CR}_d goes low and sets L12-3 high. On the trailing edge of DTSB, \overline{CR}_d goes high and produces a low on L33-3 called \overline{CR}_a . \overline{CR}_a causes a busy condition, and CR_a at inverter L23-6 is high to enable NAND gate L3-8. For each CLK, a low is generated at L3-8 which causes L11-6 to go high. Thus, SFK one-shot is fired at each CLK until the marker is sensed at the output of the shift register. At this time \overline{MKR} goes low and inhibits gate L3-8 stopping the shift pulses. MKR generates \overline{SFM} and the print cycle starts.

When the carriage return code is shifted to the shift register output, it indicates that all the characters have been printed. Rather than wait for the carriage to activate the right reed switch, time may be saved by returning it from its present position. \overline{CR}_e decoded by L16-8* fires one-shot L9A-7. On the trailing edge of L9A-7, \overline{CR}_b pulse is generated to reverse the servo logic on the 6577 board. One-shot L9A-7 provides a delay of about 6ms to allow printing of the last character before executing a return. During return, \overline{CIP} causes a prime routine to ready the printer for another line of input.

Note that \overline{SFM} fires one-shot L18-9 whose duration is approximately .2 seconds. This gives the servo-system time to stabilize between consecutive short lines. \overline{SFM} cannot be generated until this one-shot times out. This circuit would have no affect on lines with more than 10 characters.

* Actually decodes any code between Hex (00) and Hex (1F) but only a CR code Hex (0D) can be shifted into the buffer.

4.3.3.9 Audio Alarm

The audio alarm is produced by the following conditions.

1. Power-on circuit action
2. On receipt of Bell code, Hex (07)
3. On sensing paper-out condition
4. On sensing malfunction (circuit breaker open)

$\overline{\text{BELP}}$, $\overline{\text{PAPER-OUT}}$, and $\overline{\text{MALFUNCTION}}$ are gated at L4-8. When any of the three conditions occur, L8-7 one-shot is triggered for a duration of 1.1 seconds. This allows reset (pin 4) of L28 astable oscillator to go high and release the circuit. With pin 4 (reset) low the oscillator is inhibited. Output at pin 3 of L28 is buffered and fed to audio amplifier, Q3 to drive the speaker. The frequency of the audio signal is approximately 1.4kHz. Transistor Q1 in the one-shot L8-7 circuit is necessary when a large value RX_1 is used for such a large time constant.

4.3.3.10 Cover Open

When the front cover is opened, pin K_2 goes low. $\overline{\text{COVER OPEN}}$ is gated with SLCTR to cause a busy condition. If the cover is opened during buffer loading, SLCTR will be low and inhibit the busy. When CR code is received as a line terminator a CLCR pulse will be generated to set SLCTR high and enable busy gate L29-11.

4.3.3.11 Paper-Out Switch

While paper is moving over the $\overline{\text{PAPER-OUT SW}}$ actuator, the switch remains open. When the end of the form passes the switch, the switch closes making pin L_2 low. Paper out latch, L39-9 will set upon receiving a clock via L29-6 gate. Either $\overline{\text{PF}}$ or $\overline{\text{CLR}}$ will provide this clock to set the latch. L39-8 ($\overline{\text{Q}}$) is buffered and made available at the I/O interface for monitoring. $\overline{\text{Q}}$ is also used to trigger the alarm one-shot and to cause a busy condition. The Q output is used to turn on the paper-out light, and is gated with cover open at L29-8 to inhibit clock for the busy latch.

4.3.3.12 Form Override

FORM OVER-RIDE switch applies a low to the clear input of the paper out latch L39. If the switch is released, the latch will again set by PF or CLR. The latch cannot be set as long as the override switch is held down.

4.3.3.13 Ribbon Delay

When the carriage starts moving forward, RB (6577 board) goes high and forces RD high through L27-3. This causes the ribbon motor to operate. When the carriage stops moving, RB goes low and triggers ribbon delay one-shot L18-7. RD is now held high or active by the output of the one-shot for approximately 1.1 seconds. Thus, the ribbon moves constantly while printing and will remain on for 1.1 seconds after printing has ceased. Time meter output N₃ is used to indicate the amount of time that the machine is actually printing as RB is high only while the carriage is in motion.

4.3.3.14 Line Feed Delay

The line feed delay one-shot L2-9, is triggered by LFE (6577 board) to generate LFD. LFD is gated with manual line feed switch input to obtain a break between each line feed when the switch is held down.

4.3.4 MODIFICATION OF 6576 AND 6728 BOARDS

The 6576 and 6728 boards are being replaced by the 7076 and 7028 boards respectively. These boards will be 1222 LPO and Models 621W/721W/2221W compatible. Data Bit 8 (DT8), previously not used, is now incorporated to provide the underscore function for 1222 LPO. For Models 621W/721W/2221W operation add a jumper from input DT8 (J₁) to +0V on the 7076 board. On the 7076 board, DT8 is ANDed with +5VR and L5-9 at L18-6, thus, input DT8 cannot be applied to the shift register L26-7 during a POWER-ON-PRIME. (L5-9 is low during POWER-ON-PRIME.) During POWER-ON-PRIME, the marker bit is loaded into the shift register

which is later shared by DT8. At the output of the shift register, bit 8 is used to indicate a buffer full condition to start the carriage moving. Bit 8 sets L15-9 and fires one shot L11-10 generating \overline{SFM} . \overline{SFM} sets the forward flip-flop on board 6577 producing \overline{CF} . \overline{CF} thru diode D23 inhibits MKR from triggering the one-shot. This ensures DT8 can be used to underscore during the printing of characters.

On the 7028 board, b8 is used to fire the 9th solenoid (underscore). For 1222 LPO add a jumper between b8 pin (5_2) and pins 9 and 11 of L15 while removing the jumper between $+0V$ and pins 9 and 11 of L15. Note that b8 does not address the ROM as do the other bits b1 through b7. It is ORed with ROM output 09 to fire the bottom solenoid. For Models 621W/721W/2221W, remove the jumper between pin (5_2) and L15-9 and 11 and add a jumper from $+0V$ to L15-9 and 11.

SECTION

5

**ADJUSTMENT,
REMOVAL AND
REPLACEMENT
PROCEDURES**

SECTION 5
ADJUSTMENT, REMOVAL AND REPLACEMENT PROCEDURES

5.1 INTRODUCTION

This section describes the adjustment, removal and replacement of each major mechanical assembly in the MODEL 72 printer.

The electrical section contains voltage and timing adjustment procedures and a listing of all the electrical component boards used in the Model 72 printer.

The mechanical section contains the mechanical and electromechanical adjustment checks, adjustment procedures and removal/replacement procedures.

5.2 ELECTRICAL ADJUSTMENTS (REFER TO FIGURE 5-1)

CAUTION:

To perform the following print timing adjustments
the print head should be disconnected electrically.

- (a) Print Head Adjustment - To prevent damage to the print head while making the following adjustments, disconnect the print head electrically by disconnecting the finger board providing solenoid currents. Then run a program for continuous printing. Each adjustment required for print timing is listed in Table 5-1. Perform the +5VR and -12VR adjustments before proceeding to print timing.
- 1) WS Adjustments - WS is generated by the optical sensor as it passes the timing fence marks. This signal must be adjusted by R38 on the 6577 board for a complete cycle of $925 \mu\text{s} \pm 25 \mu\text{s}$ monitored at Pin L_3 of the 6577 board. R11 must then be adjusted to obtain a squarewave (50% duty cycle).

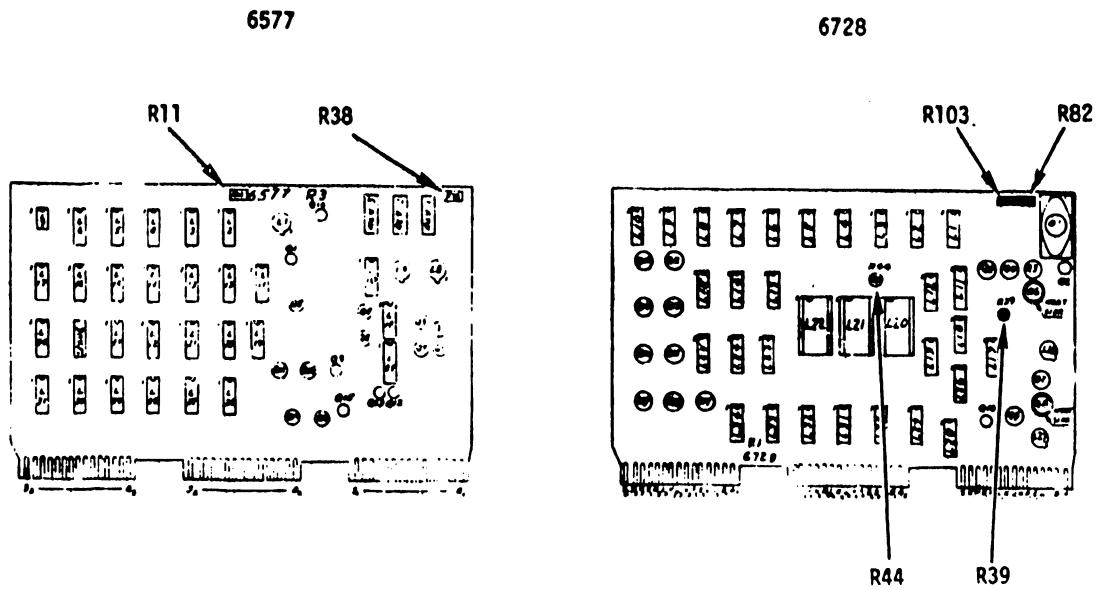
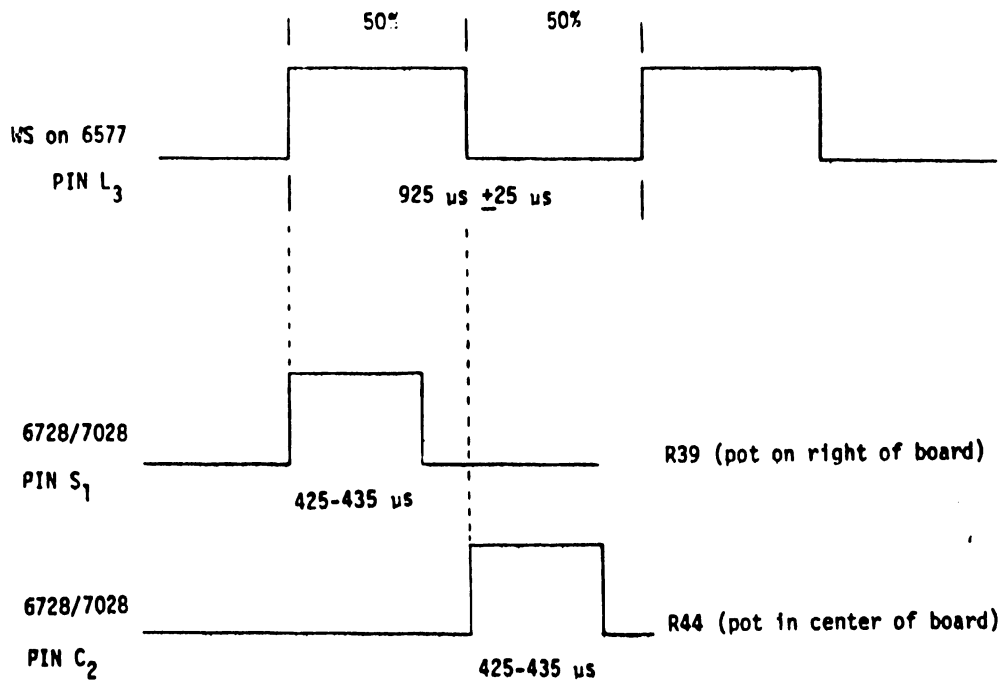

FIGURE 5-1 VOLTAGE AND WS TIMING ADJUSTMENTS

- 2) After obtaining the proper waveform for WS (Figure 5-1), the following pulses should be checked and/or adjusted.

WS trailing edge - Adjust R44 on the 6728/7028 board for a 425-435 μ s positive pulse at L11-6 of the 6728/7028 board.

WS leading edge - Adjust R39 on the 6728/7028 board to obtain a 425-435 μ s positive pulse at L11-10 of the 6728/7028 board.

The WS leading and trailing edge strobes are only present during the printing period. Replace print head solenoid finger board connector.

- 3) The push-button maintenance switch located on the rear of the chassis is used to sweep the carriage forward and return without printing. It also can be used to test the SW1 deceleration switch for the carriage return.

NOTE:

1. Whenever the 6577 or 6728/7028 board are interchanged, these adjustments must be checked.
2. All timing pots should be secured with Glyptal after adjustment to prevent any changes due to vibrations in the printer.

TABLE 5-1

LEVEL OR SIGNAL	BOARD	LOCATION	MEASUREMENT	ADJUSTMENTS
+5VR	6728/7028	Pin B ₁	+5 volts \pm .25 volts	R82
-12VR	6728/7028	Pin 13 ₁	-12 volts \pm .25 volts	R103
WS	6577	Pin L ₃	925 μ s \pm 25 μ s full cycle squarewave (50% duty cycle)	R38 R11
WS (TRAILING EDGE)	6728/7028	Pin C ₂	425-435 μ s positive pulse	R44
WS (LEADING EDGE)	6728/7028	Pin S ₁	425-435 μ s positive pulse	R39

The complement of Electrical Circuit Boards used in Model 72 are listed in Table 5-2. Refer to Figure 5-1A for locating the position of Electrical Circuit boards on the Electrical Chassis Assembly.

TABLE 5-2

<u>ELECTRICAL CIRCUIT BOARDS</u>	<u>PART NUMBER</u>
1) Resistor Module (Plugs in J7)	210-6568
2) Phototransistor (VFU)	210-6574
3) LED (LAMP) MTG Board (VFU)	210-6575
4) I/O Control & Data Storage (3-Conn)	210-6576
5) I/O Control Data Storage & Underscore (3-Conn)	210-7076
6) Format & Printing Control (3-Conn)	210-6577
7) Motherboard	210-6579
8) Heat Sink Assy.	270-0261
9) Diode Board	210-6704
10) EA Memory & Regulator (3-Conn)	210-6728
11) EA Memory & Regulator & Underscore (3-Conn)	209-7028
12) Component Board (Control Panel)	210-6734
13) Matrix Interface Board (2-Conn)	210-6751*

*NOTE: Used in Models 621W, 721W only.

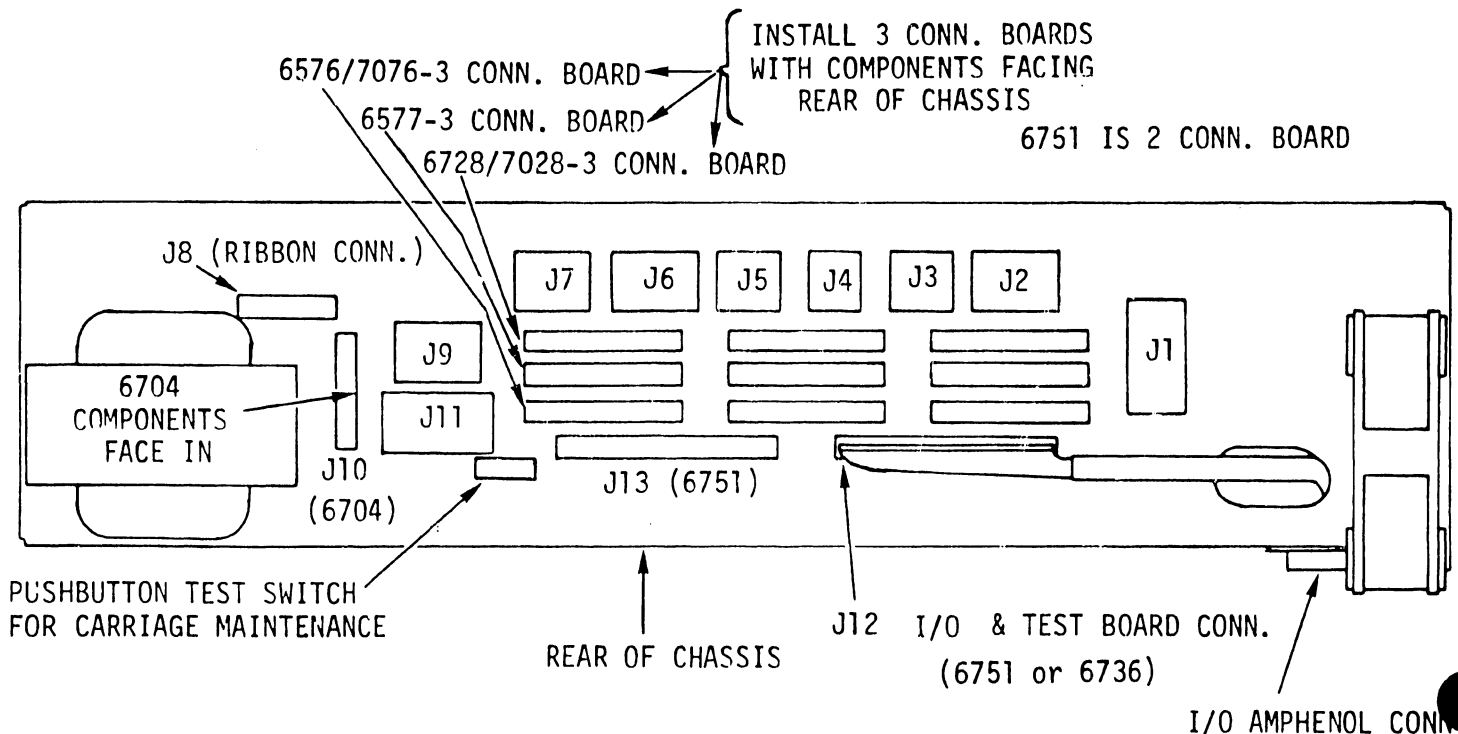

FIGURE 5-1A ELECTRICAL CHASSIS ASSEMBLY LAYOUT

5.3 MECHANICAL AND ELECTRO-MECHANICAL ADJUSTMENT, REMOVAL/REPLACEMENT

INDEX

- 5.3.1 Striker Bar*
- 5.3.2 Ribbon Guides
- 5.3.3 Main Drive Belt*
- 5.3.4 Paper Guides*
- 5.3.5 Print Head*
- 5.3.6 Timing Fence*
- 5.3.7 Reed Switches*
- 5.3.8 Reed Switch Magnet*
- 5.3.9 Paper Feed Sprockets*
- 5.3.10 Vernier Clutch
- 5.3.11 Vertical Format Unit V.F.U.
- 5.3.12 Ribbon Drive Assembly*
- 5.3.13 Paper Movement Belts*
- 5.3.14 Tach and Drive Motors
- 5.3.15 Carriage Assembly Removal and Replacement
- 5.3.16 Frame Assembly
- 5.3.17 Front Cover Removal and Replacement

*Contain their own removal and replacement section.

5.3.1 STRIKER BAR (See Figure 5-2)

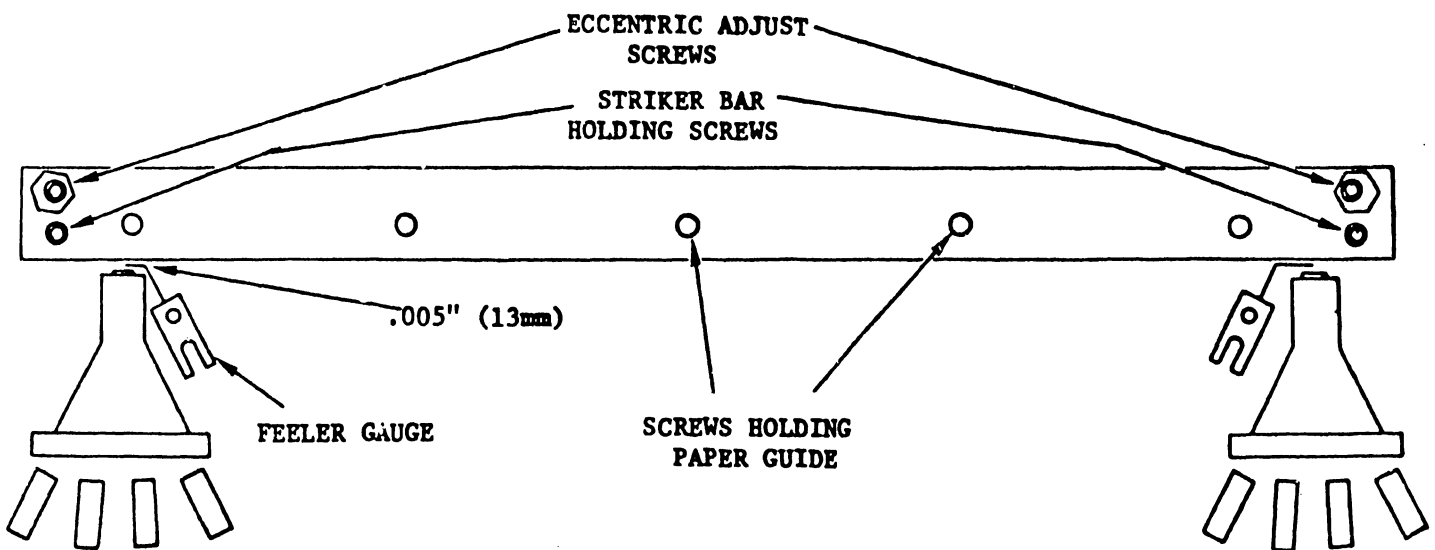

FIGURE 5-2 STRIKER BAR ADJUSTMENT

(a) Adjustment Check

- 1) With the print head in the far left position and ribbon removed from the ribbon guides, turn the penetration knob to the full clockwise direction (to move the print head as close as possible to the striker bar). A .005" (.13 mm) gauge should just fit between the striker bar and the solenoid wires.
- 2) Move the head to the far right position and check the same gap.

(b) Adjustment:

- 1) The print head must be as close as possible to the striker bar.
- 2) Remove the ribbon from the print head to allow for proper measurement.
- 3) Remove the caps from the eccentric ribbon guides.
- 4) Back the eccentric ribbon guides so they are as far as possible from the striker bar by loosening the Allen screws and then turning the ribbon guides away from striker bar.
- 5) Loosen the two Allen screws holding the striker bar.
- 6) Adjust the striker bar in or out to meet adjustment tolerances by adjusting the two eccentric nuts. Some units do not contain the eccentrics but have additional Allen screws. With these units, loosen the Allen screws and move the striker bar in the desired direction.
- 7) Readjust the eccentric ribbon guides. See Section 5.3.2.
- 8) Check lower paper pan adjustment. See Section 5.3.4.

(c) Striker Bar Removal and Replacement

- 1) Back head as far away as possible from the striker bar.

- 2) Remove the five Phillips screws that attach the striker bar to the upper paper guide.
- 3) Remove the two Allen screws within the eccentrics and two Allen holding screws. Lift the striker bar from the frame assembly.
- 4) Reverse procedure to reassemble and then readjust striker bar.
- 5) Check the lower paper guide adjustment. See Section 5.3.4.

5.3.2 RIBBON GUIDES

(a) Adjustment Check

- 1) Using the penetration knob, move the head in towards the striker bar as close as it will go. There should be a gap of $.005" \pm .001"$ ($.13 \text{ mm} \pm .02 \text{ mm}$) between the striker bar and head bearing, if not, adjust striker bar (Section 5.3.1).
- 2) Continue by checking ribbon guides 1, 2 and 3. The ribbon guides should be $.015"$ ($.4 \text{ mm}$) from the striker bar. See Figure 5-3.

(b) Adjustment

- 1) Remove the caps covering Allen screws.
- 2) Loosen the Allen screws inside the ribbon guides and move the guides away from the striker bar.
- 3) Place a $.005"$ ($.13 \text{ mm}$) gauge between the striker bar and head bearing (solenoid wires) and move the head in until the gauge is held snugly between the bearing and striker bar.
- 4) Loosen Allen screws, turn the guides, 1, 2 and 3 by hand until they are $.015"$ ($.4 \text{ mm}$) from the striker bar and retighten the Allen screws.

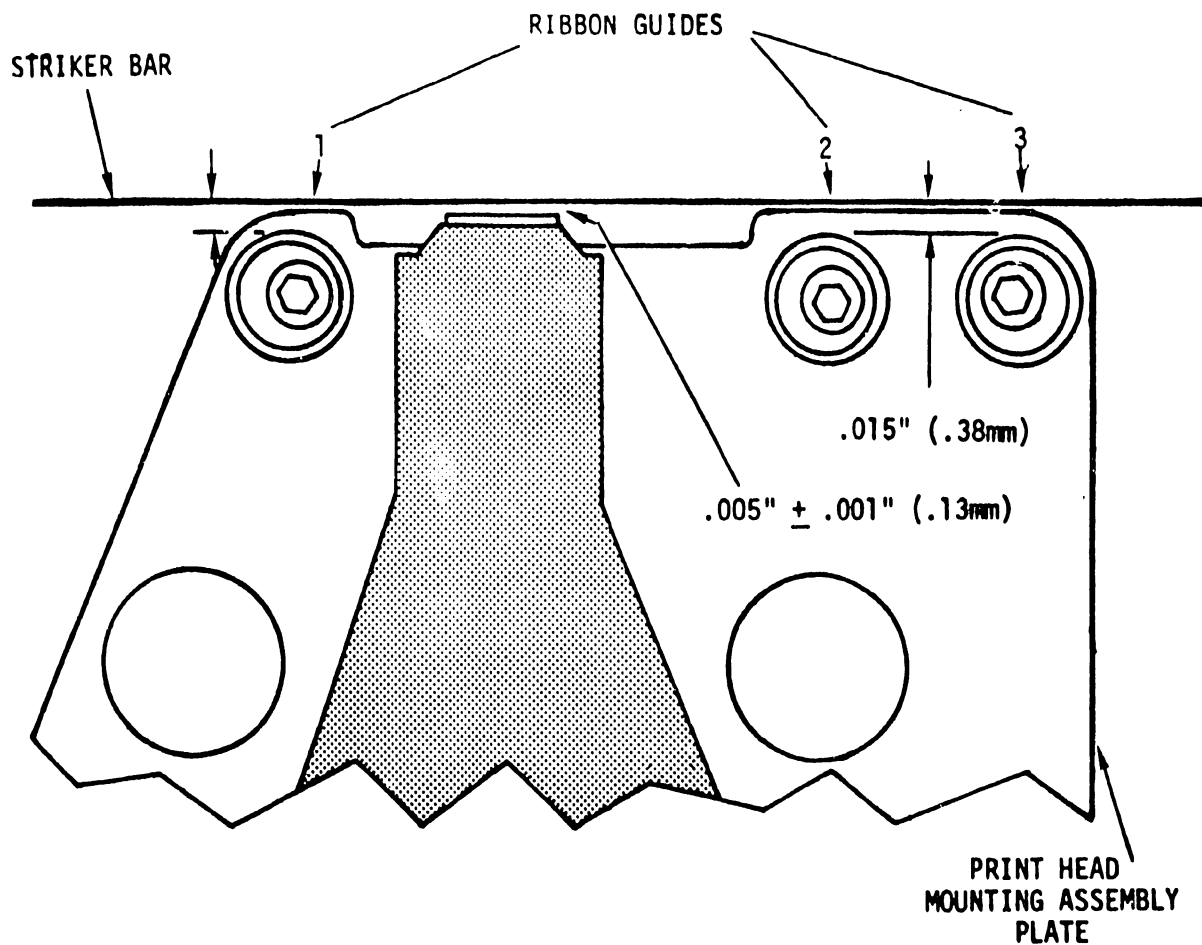

FIGURE 5-3 RIBBON GUIDES AND PRINT HEAD ADJUSTMENT

5.3.3 MAIN DRIVE BELT

(a) Adjustment Check

WARNING:

Power must be off during this procedure since the carriage will forcibly return when brought to the extreme right hand position.

- 1) Move the carriage to the extreme right hand position.
- 2) Using a spring gauge and scale, deflect the middle of the belt .31" or 5/16" (7.9 mm). The gauge should read 1 lb \pm 2 oz. (Figure 5-4).
- 3) The pulley bracket and base casting should be parallel.

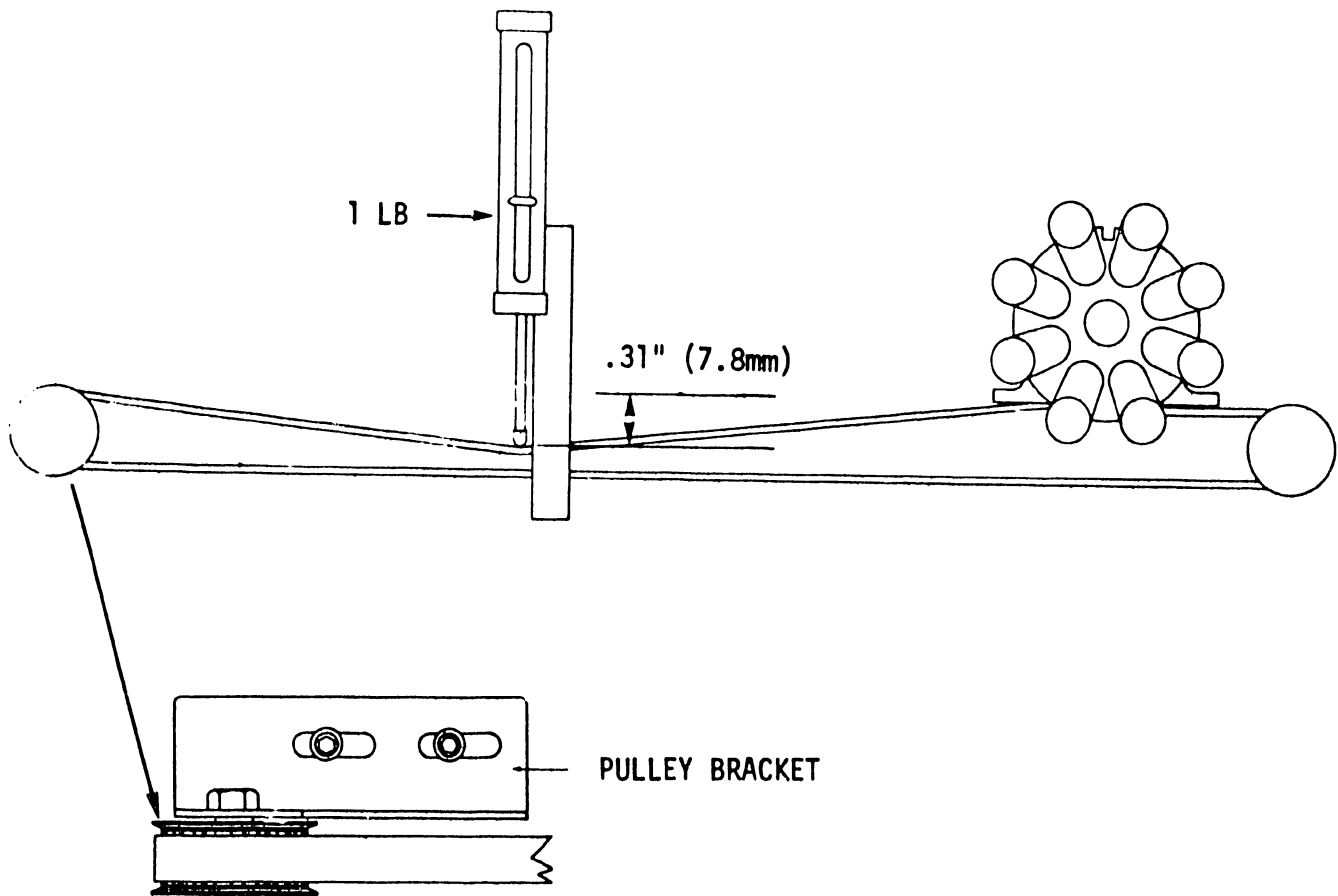

FIGURE 5-4 MAIN DRIVE BELT ADJUSTMENT

(b) Adjustment

Loosen the two Allen screws holding the pulley bracket and move the pulley bracket in the desired direction; retighten the screws.

(c) Main Drive Belt Removal and Replacement

- 1) Remove the carriage assembly from the carriage shaft. See Section 5.3.15.
- 2) With carriage removed and assembly upside down, remove the eccentric bearing spring. (See Figure 5-5.)
- 3) Remove 3 screws, hex screw post and belt holding plate, remove belt.
- 4) To replace, reverse procedure.

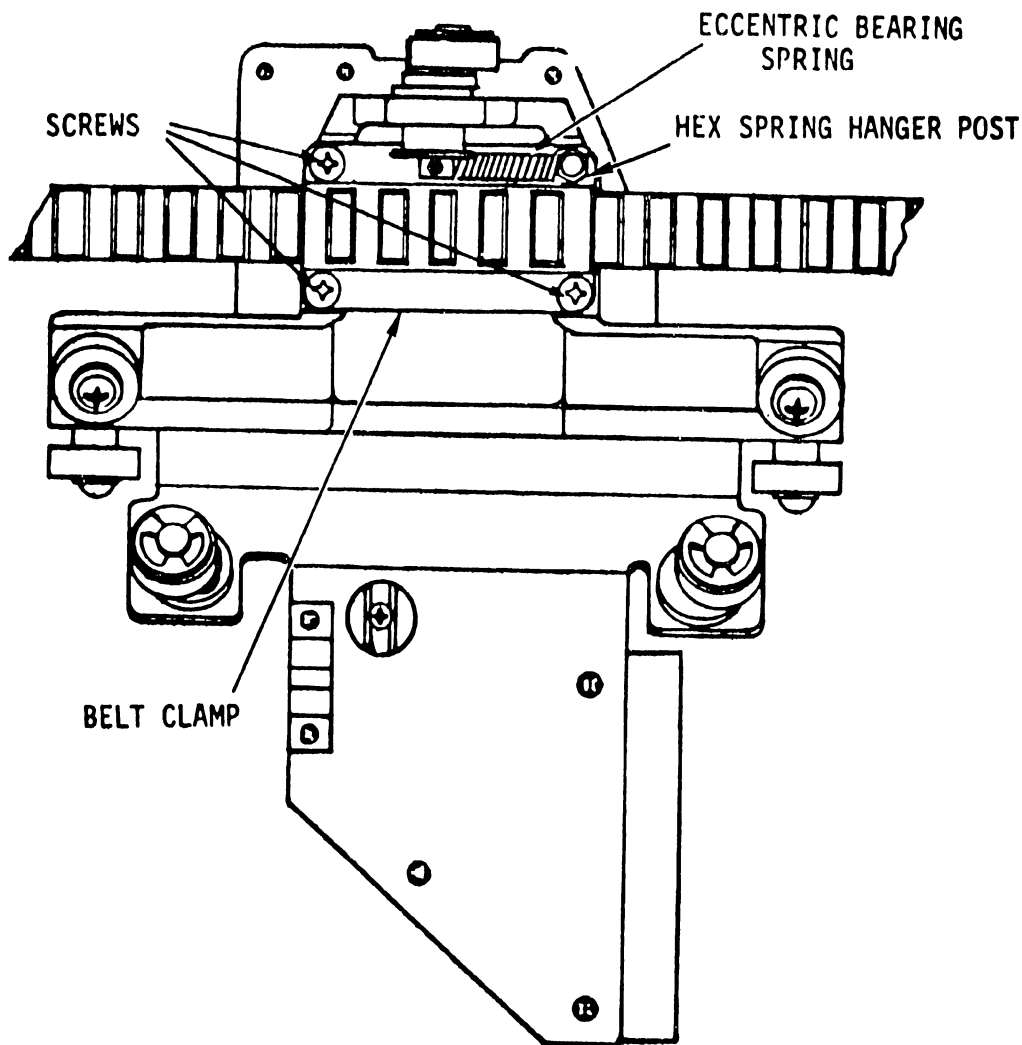

FIGURE 5-5 MAIN DRIVE BELT REMOVAL AND REPLACEMENT

5.3.4 PAPER GUIDES

There are three versions of the paper guide assemblies. Because each of the adjustments is different, step 2 of the adjustment check is divided between the two early models and a late model. The two early models No. 1 and No. 2 are top feed types and the late model is a bottom or front loader feed. Each will be discussed separately.

(a) Adjustment Checks

- 1) The adjustable paper guide must be parallel to the striker bar across the entire bar for all three versions. (See Figure 5-6.)

EARLY MODEL #1 (FRONT)

A

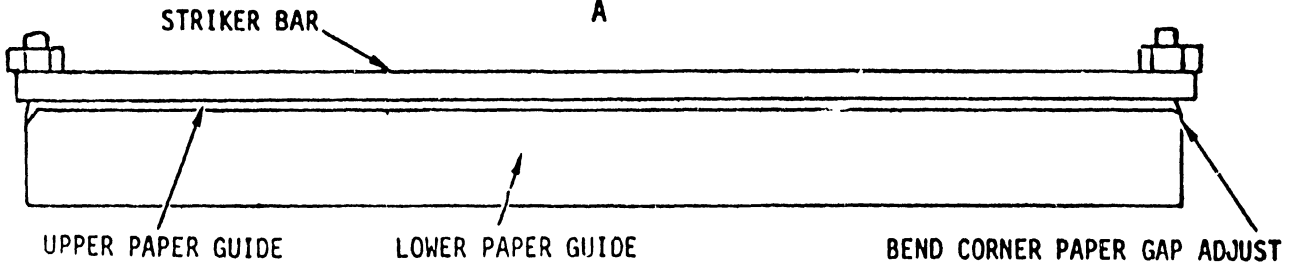

EARLY MODEL #2 (FRONT)

B

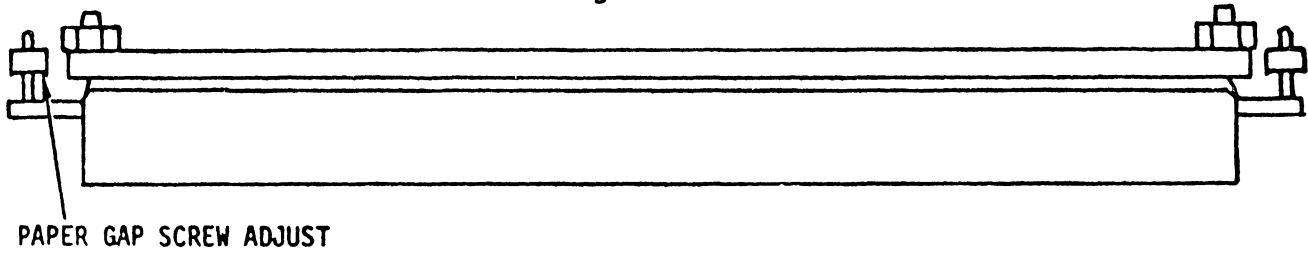

LATE MODEL

C

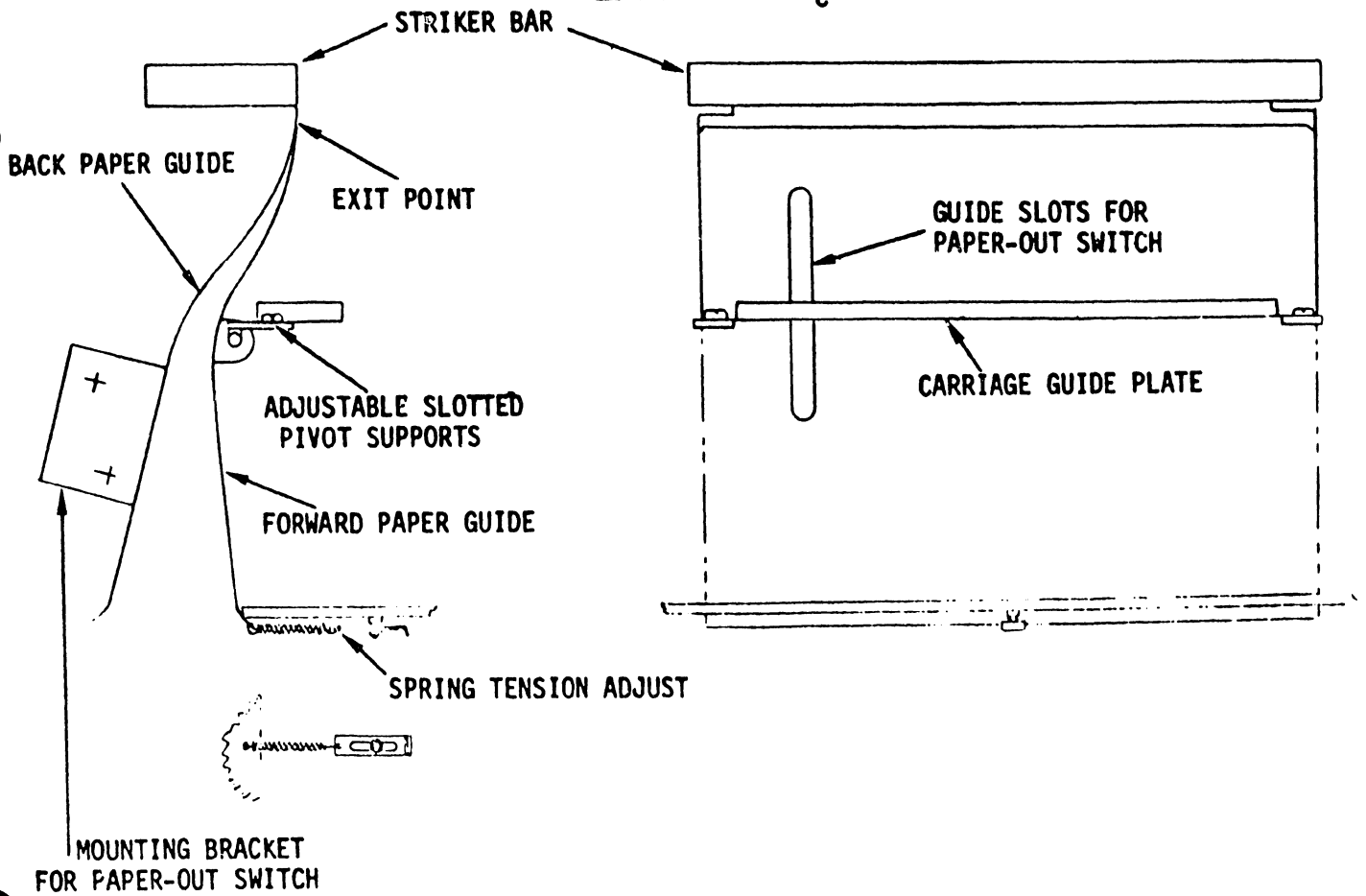

FIGURE 5-6 MODEL 72 PAPER GUIDE DESIGNS

2) *Early Models*

The point at which the paper exits the paper guides should be the only place where the two guides contact one another. This may be difficult to see, so it is suggested that a piece of paper be pushed squarely through the guides as if paper was being loaded. In doing this a slight resistance should be felt along the entire width of the paper. This resistance should be very slight and only found just as the paper begins to appear at the front of the machine.

If the two guides contact at another point rather than at the front of the machine as below, in Figure 5-7, a bind will be felt long before the paper exits the guides.

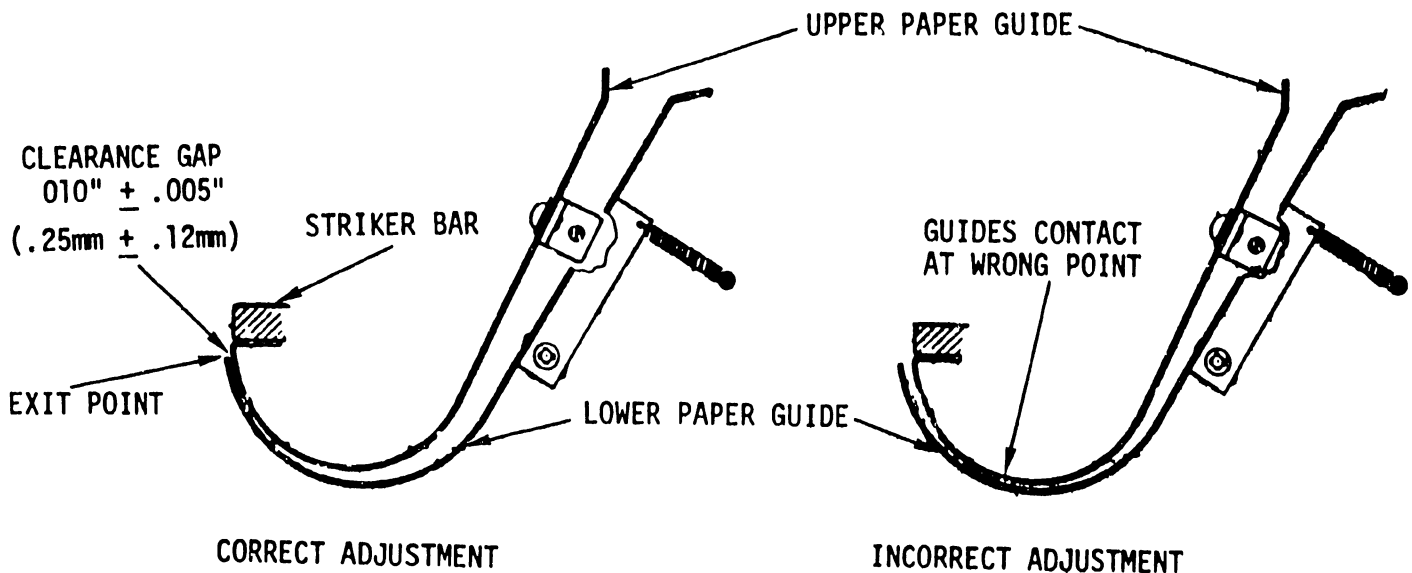

FIGURE 5-7 PAPER GUIDE ADJUSTMENTS

If adjusted incorrectly, the guides will feed the paper toward the print head instead of parallel to it. This will cause the paper to bubble in front of the platen causing streaks or possibly causing the ribbon to be kicked off its guides during loading of paper or top of form execution.

A uniform gap of $.010'' \pm .005''$ ($.25 \text{ mm} \pm .12 \text{ mm}$) should be maintained along the entire paper guide between the lower guide and the upper guide exit point. However, a manual check of the resistance to paper feed through the guides is recommended.

3) *Late Model*

The late model has a bottom paper feed system. See Figure 5-6. Like the early models there is a fixed and adjustable guide but they are shaped differently. The exit point is the only contact surface between the guides and the paper feed resistance should be uniform along the width of the paper. Due to the change in the shape of the guides there is no gap clearance provided. The self-locking effect in the curved early models has been eliminated. Insure guide parallelism with the striker bar.

(b) Adjustment of Paper Guides

The early model lower paper guide is the only guide that requires an adjustment, however, since the upper guide is mounted on the striker bar, the lower paper guide must be adjusted if the striker bar is moved. The adjustment of the lower guide is performed by moving two hex screws on the outside of the left and right side frames. These Allen head screws are located behind each ribbon spool. The holes where these screws are inserted are oversize allowing excess play. Use them as follows:

- 1) Loosen both locking screws of the lower paper guide (see Figure 5-8). If the unit is an early #2 model, back off the height adjusting screws on either end of the striker bar so no contact is made between the guide and the screws (Figure 5-6B).
- 2) Hold the rear middle of the lower paper guide and push its upper rear edge down. This causes the two guides to make contact. While observing each side of the guides at their front edge, move the lower guide until it contacts the upper guide at the exit point (Figure 5-7). When this is complete, continue to hold the guide while checking for parallelism. When the guides are parallel, tighten the locking screws (Figure 5-8). Do not release the guide until both screws are tight.

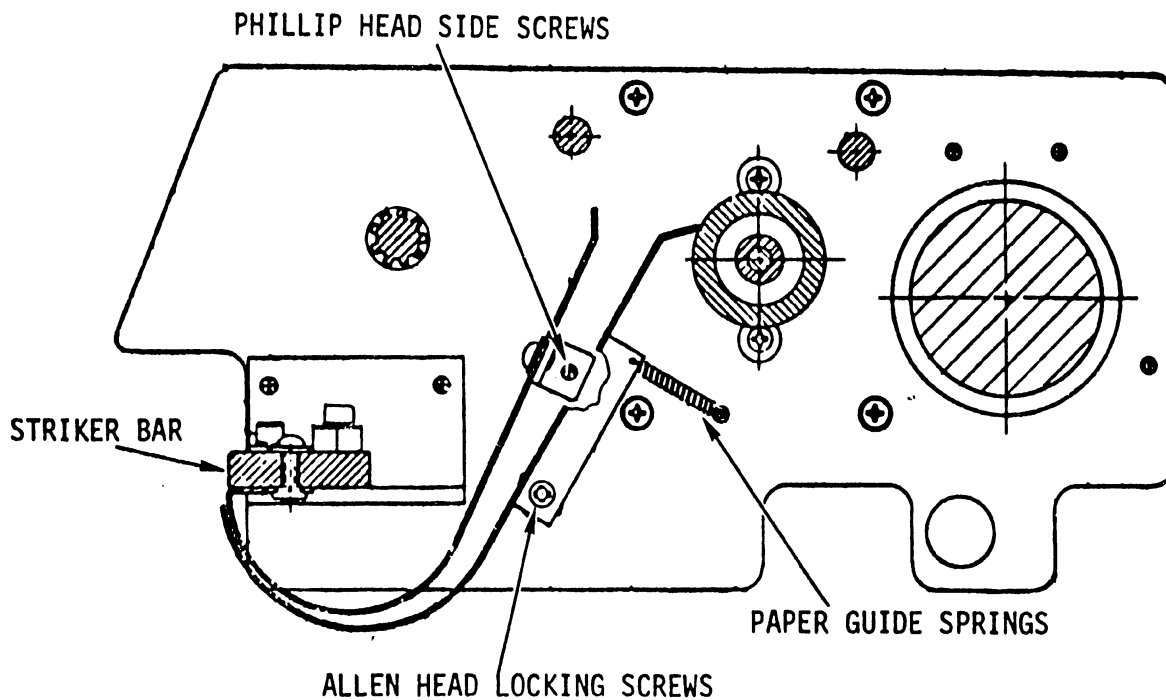

FIGURE 5-8 EARLY MODEL PAPER GUIDE ADJUSTMENT

3) *Early Model No. 1*

The lower paper guides contain a bend on one of the front corners to prevent paper lockup during a top of form. It is possible that this bend could be too big causing the paper to bubble in front of the striker bar. Form this bend to obtain a gap of $.010'' \pm .005''$ ($.25 \text{ mm} \pm .12 \text{ mm}$) between the two guides.

Early Model No. 2

Adjust the two height screws (Figure 5-6B) to create a gap between the two guides of $.010'' \pm .005''$ ($.25 \text{ mm} \pm .12 \text{ mm}$).

Late Model (Bottom Feed)

The late model forward paper feed guide is the only guide that requires adjustment since the back guide is attached to the striker bar. Any movement of the striker bar would result in a forward guide adjustment. See Figure 5-6C. The adjustments for parallelism

of the forward guide with the striker bar are two Allen head screws located on either side of the carriage guide plate. These screws allow slotted pivot supports to be adjusted for paper guide contact all the way along the exit point. The only other adjustment is the tension spring located under the baseplate of the printer. This adjustment will accommodate paper specifications as listed in APPENDIX A.

(c) Paper Guide Removal and Replacement

Early Models

- 1) Remove frame assembly from casting (see Section 5.3.16).

NOTE:

To remove the lower guide, perform steps 2, 3 and 4. Steps 5 through 7 are for removing the upper guide.

- 2) Remove paper guide springs (Figure 5-8).
- 3) Remove paper-out switch wires.
- 4) Remove locking screws on each side frame. This allows the lower guide to be tilted up and out from the rear. While doing this, the hex nuts will probably fall out of the holes in the paper guide. They fit on the outside of the guide pointing in (see Figure 5-8).

NOTE:

The lower guide must be removed before the upper guide can be removed.

- 5) Remove the five Phillips screws from the striker bar (Figure 5-2).
- 6) Remove the two side screws which attach the guide to the side frames (Figure 5-8).

- 7) Pull the guide out from the rear.

Late Model

NOTE:

To remove the forward guide, perform steps 7, 8 and 9. Step 10 and 11 is for removing back guide.

- 7) Remove tension spring from bottom of forward guide under printer baseplate.
- 8) Remove paper-out switch wires.
- 9) Remove the two Allen head screws that secure the two pivot supports and carefully lower the guide through the bottom of the printer baseplate.
- 10) Remove the five Phillips screws from the striker bar and carefully lower the back guide through the bottom of the printer baseplate.
- 11) Replace guides in the order removed.

5.3.5 *PRINT HEAD ADJUSTMENT*

(a) Adjustment Check

- 1) Remove the print head from the carriage assembly by disconnecting finger board from connector and removing the two mounting screws, one on each side of the print head.
- 2) With a jewelers loupe (magnifier) look at the head bearing (Figure 5-9). All the solenoid wires must protrude .002" - .005" (.05 mm - .12 mm) from the bearing surface.

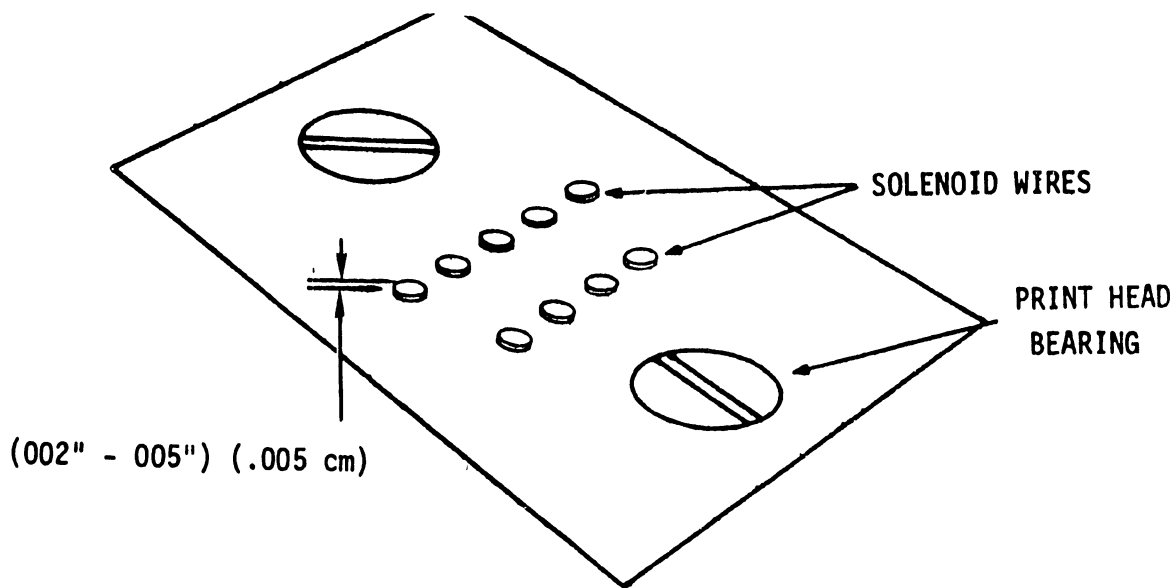

FIGURE 5-9 SOLENOID WIRE ADJUSTMENT

(b) Adjustment of Print Head

- 1) Remove the head cover by removing the two Phillips screws.
- 2) Unlock the desired solenoid by loosening its corresponding nylon tip locking set screw. These screws are positioned radially at the rear of the print head. If the set screw is the metal tip type, replace it with a nylon tip set screw Part #650-4086 (8-32 x $\frac{15}{64}$).
- 3) Turn the solenoid to be adjusted in or out while watching the solenoid wire at the bearing. See Figure 5-10.

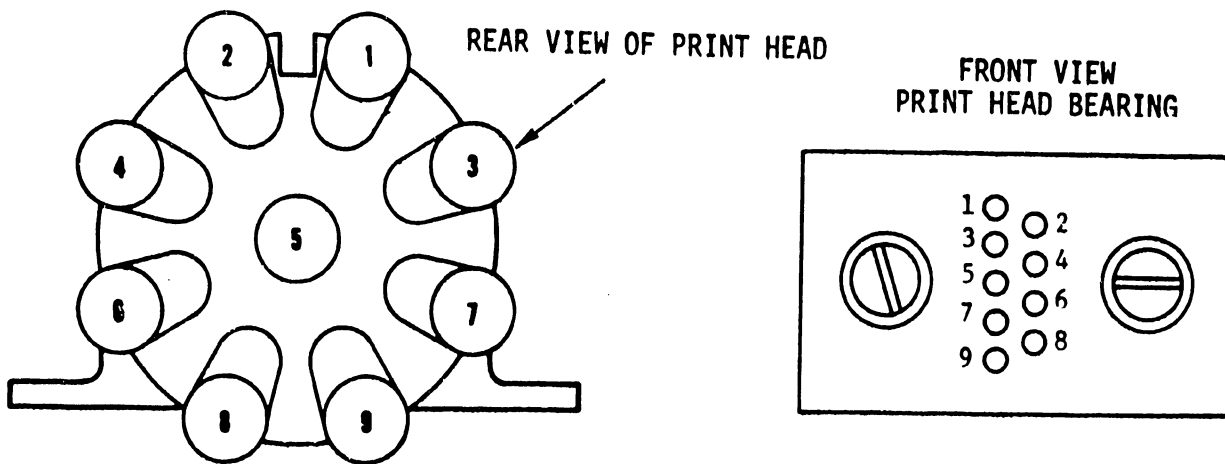

FIGURE 5-10 IDENTIFICATION OF SOLENOIDS

- 4) Replace and tighten nylon tip set screw and check the bearing again.

(c) Solenoid Removal and Replacement

NOTE:

If more than one solenoid requires replacement, only one solenoid should be removed, replaced and adjusted at one time. Refer to Wang ISN #96 for two or more print wire failures in the same solenoid position. Model 72 Print Head Failure Analysis Forms can be obtained from the Customer Engineering Support Group.

- 1) Remove print head from carriage assembly by removing the two screws holding head to carriage assembly.
- 2) Remove print head cover.
- 3) Unsolder solenoid wires from 6572 fingerboard.
- 4) Loosen desired lock set screw and unscrew solenoid from head casting. See Figure 5-11.

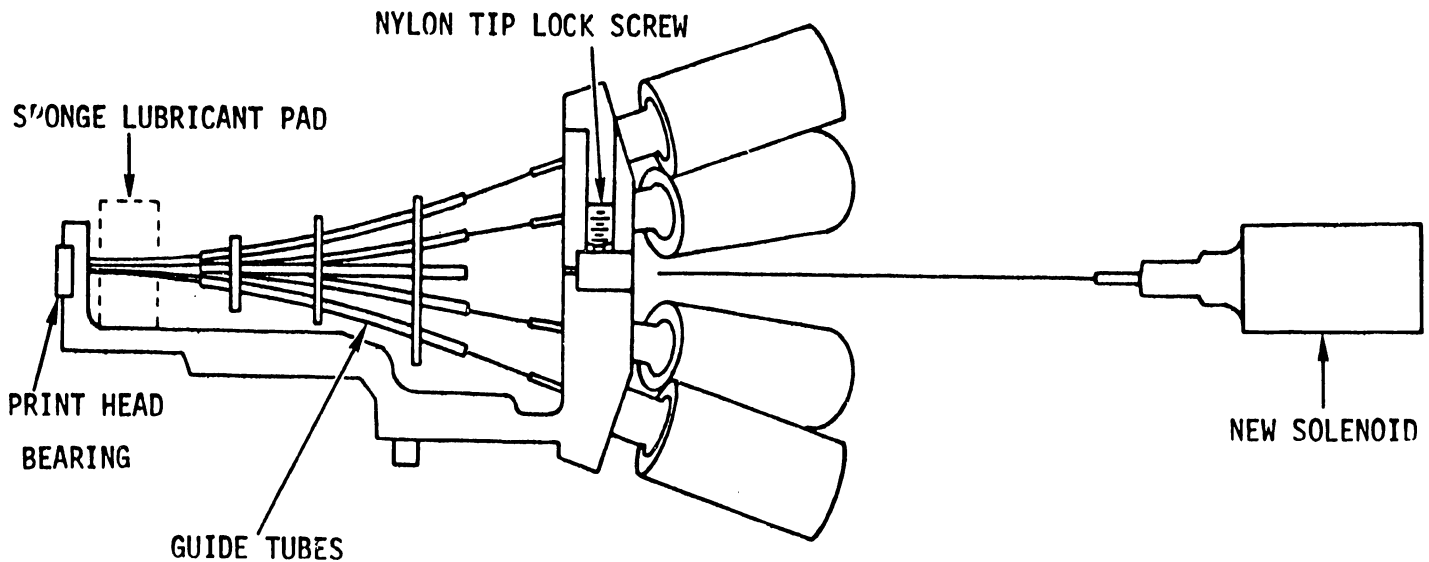

FIGURE 5-11 REMOVAL AND REPLACEMENT OF SOLENOIDS

- 5) Remove lubricant pad. Remove any broken wire material at pad location.
- 6) Dip the new solenoid wire into the lubricant (obtained from the Home Office; no other lubricant can be substituted). See lubrication procedure in Section 6. Cautiously insert the new solenoid being careful not to bend the new print wire. With a pair of tweezers guide the wire into its guide tube and then into its respective bearing hole. Relock the solenoid with nylon tip set screw. Separating the two rows of print wires with a feeler gauge eliminates the confusion created by nine wires and aids in guiding the new solenoid wire into the bearing.

CAUTION:

The next step is lubricating the new solenoid wire and the bearing. Lubrication is necessary or damage to the new wire will result.

- 7) Solder solenoid wires to 6572 fingerboard.
- 8) Dip the lubricant pad into the lubricant material (obtained from Home Office; no other lubricant can be substituted) and place it back into the print head. Tip the head forward to allow the lubricant to reach the tip of the print wires.
- 9) Replace print head on carriage assembly and operate for several minutes to insure that lubricant is distributed (lubricant has a wax base and does not flow readily).
- 10) Dab entrance to each guide tube with swab soaked with lubricant and run head in printer again.

5.3.6 TIMING FENCE

(a) Adjustment Check

- 1) Fence and optical coupler should not contact one another.

- 2) The distance between the face of the fence and the photocoupler should be consistent along the length of the fence with a gap of .010" - .012" (metric .25 - .30 mm). (See Figure 5-12.)
- 3) There must be a gap of $.290" \pm .010$ (.74 cm \pm .03 cm) between the top of the carriage and the top of the fence at both ends of the fence.

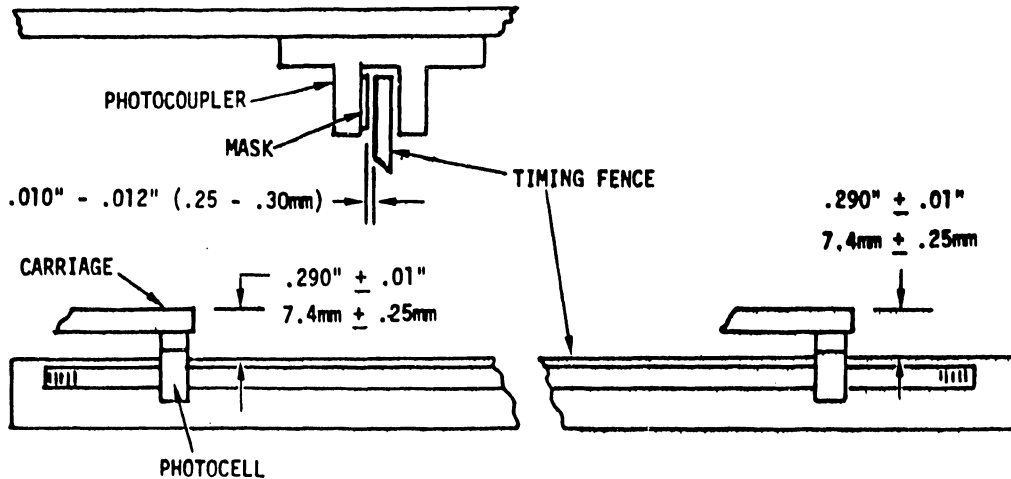

FIGURE 5-12 TIMING FENCE ADJUSTMENT CHECKS

(b) Adjustment

Parallelism

- 1) Loosen the holding screws of the fence bracket so they still hold the fence well enough so that tapping it with a screwdriver to move it is required. (See Figure 5-13.)
- 2) Move the fence in the desired direction to obtain a .010" - .012" gap (.25 - .30 mm) between the optical sensor and fence by tapping the bracket with a screwdriver. Move the carriage from side to side to make sure the fence and photocoupler are parallel. Retighten the bracket holding screws.

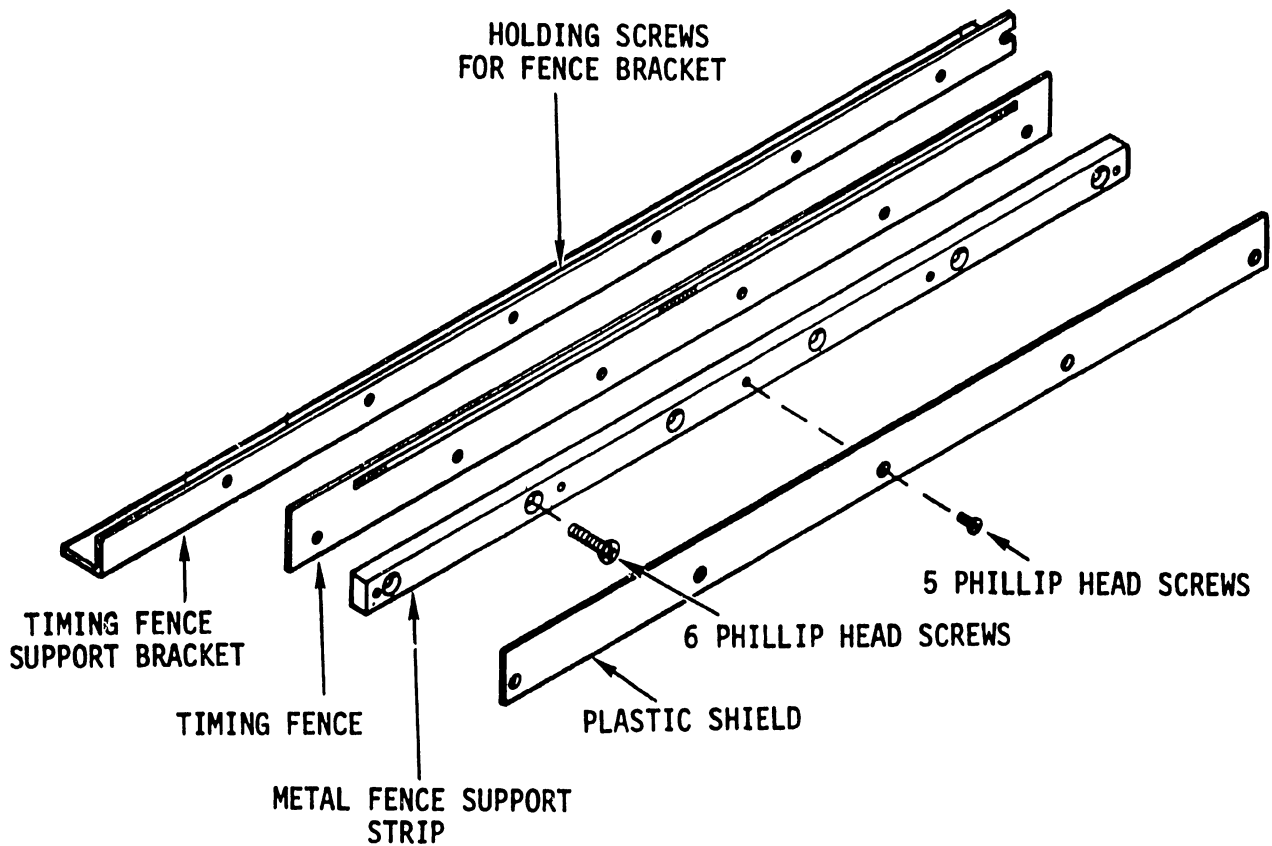

FIGURE 5-13 TIMING FENCE ADJUSTMENTS (PARALLELISM & HEIGHT)

Height

- 3) Remove the five small Phillip head screws which secure the protective clear plastic shield on the front of the timing fence assembly.
- 4) Loosen the six holding screws in the face of the metal fence support strip. Adjust the fence height to obtain $.290'' \pm .01''$ ($.74 \text{ cm} \pm .03 \text{ cm}$) between the carriage bottom and the top of the fence.

(c) Timing Fence/Photocoupler Removal and Replacement

Timing Fence

- 1) Remove the front cover of the printer. See Section 5.3.17.

- 2) Remove the five flathead screws holding the clear plastic shield in front of the fence.
- 3) Remove the six flathead screws holding the fence support strip and the fence. Slide the fence to the right, away from the photocoupler.
- 4) Replace the fence in the opposite order and check the fence adjustment.

Photocoupler

- 1) Loosen the retainer clamp that secures the photocoupler and solenoid fingerboards and remove the photocoupler fingerboard. (The clamp is held by one screw.)
- 2) Loosen the two holding screws clamping the photocoupler to the carriage and slide the photocoupler out. See Figure 5-14.

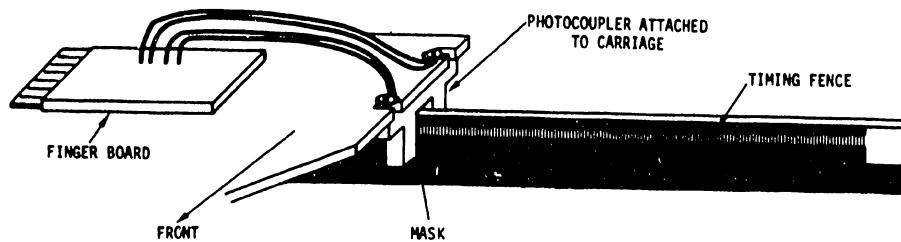

FIGURE 5-14 PHOTOCOUPLER REMOVAL AND REPLACEMENT

- 3) When reinstalling the photocoupler, be careful not to damage the wires. The wires are inserted in the slots before the screws. The photocoupler has a mask on one window. This mask will be on the window to the front of the timing fence.

5.3.7 REED SWITCHES

(a) Adjustment Check

- 1) With power off and the printer cover open, push the carriage against the left hand rubber bumper. Turn power on, the servo circuit breaker should remain set. If the circuit breaker trips, an adjustment of the reed switch, SW0 or magnet must be made. See section 5.3.7 and 5.3.8.
- 2) With power off, push the carriage somewhere near the center of the machine. Turn power on. The carriage should return to the left. The right side of the photocoupler must be between .125" and .25" (.32 cm and .64 cm) to the left of the 1st character position on the timing fence.

WARNING:

During the following procedure, as the carriage reaches the right hand limit switch it will automatically generate a carriage return. Use your left hand to hold the head cover and pull the carriage to the right. This allows the head to slip from your hand easily. AVOID PERSONAL INJURY.

- 3) A carriage return should occur automatically when the left side of the photocoupler is between .125" and .25" (.32 cm and .64 cm) after the last character position on the timing fence. Check by slowly pulling the carriage from left to right and watching the photocoupler position in relation to the timing fence.

(b) Adjustment

WARNING:

Because the screwdriver used may be magnetic, always adjust the reed switches with power off. The accidental closing of these switches could be hazardous.

Adjust the switches by loosening the screws holding the reed switch brackets and use the previous adjustment checks in steps 1, 2 and 3. See Figure 5-15.

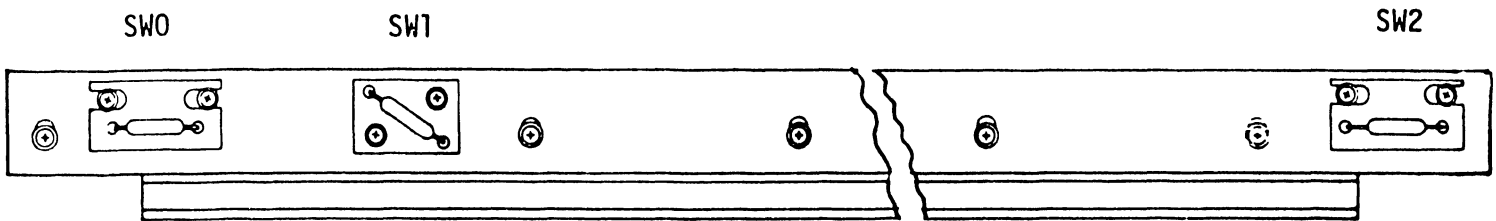

FIGURE 5-15 REED SWITCH ADJUSTMENTS

During the adjustment check if a reed switch appears to be faulty or misadjusted; shut off the power. Pull the reed switch plug connector on the right side of the chassis. Proceed to check the defective reed switch by using an ohmmeter for continuity while moving the carriage magnet over the suspected switch or switches. The black lead on the plug is common to all 3 switches. The color code for each switch is as follows:

SW0 (Violet), SW1 (Green) and SW2 (Blue).

(c) Reed Switch Removal and Replacement

Timing Fence Assembly Removal and Replacement

- 1) With power off, unplug connector from reed switches.
- 2) Remove the five holding screws from the fence and switch assembly and slide the assembly to the right to clear the photocoupler on the carriage. (Refer to Figure 5-13.)
- 3) Replace by reversing procedure.

Switch Removal and Replacement

- 1) Remove screws holding switch bracket. (Do this step first to prevent soldering iron from damaging the fence.) (Refer to Figure 5-13.)

- 2) Place the switch away from the fence and remove the wires from the solder lugs.
- 3) When replacing the switch, do not overheat the lugs and damage the switch.
- 4) Readjust the switch.

5.3.8 REED SWITCH MAGNET

(a) Adjustment Check

Looking from the side of the carriage, the magnet should be centrally located over the reed switches, and the slot of the magnet should face the front of the machine.

(b) Adjustment

Loosen the magnet holding screw while holding the hex spacer and move the magnet to desired location. See Figure 5-16.

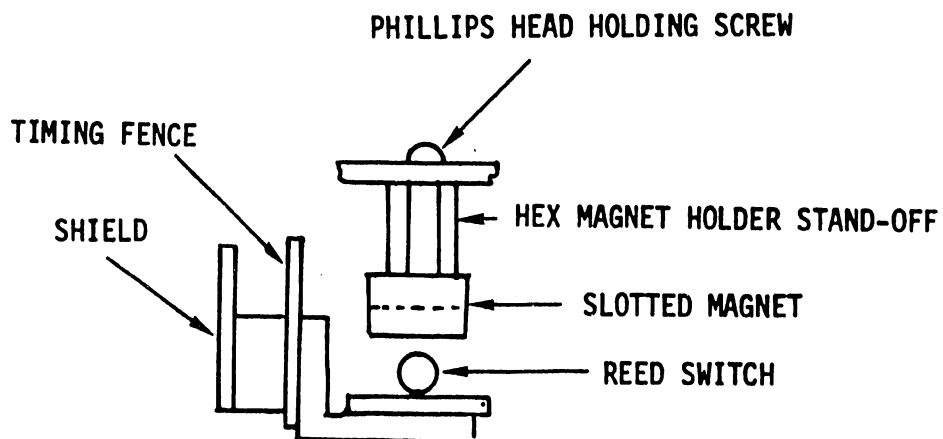

FIGURE 5-16 REED SWITCH MAGNET ADJUSTMENT

(c) Reed Switch Magnet Removal and Replacement

- 1) Push carriage to the left hand margin.
- 2) Remove print head.
- 3) With long nose pliers hold the hex spacer while removing the holding screw.
- 4) Replace in opposite manner.

5.3.9 PAPER FEED SPROCKETS

(a) Adjustment Check

- 1) With each of the sprocket wheel covers closed, (Figure 5-17), there should be a gap between cover and paper feed sprocket of .025" to .030" (.64 mm to .76 mm).
- 2) The teeth of the sprocket should be centrally located in the cover slot as shown in Figure 5-17.

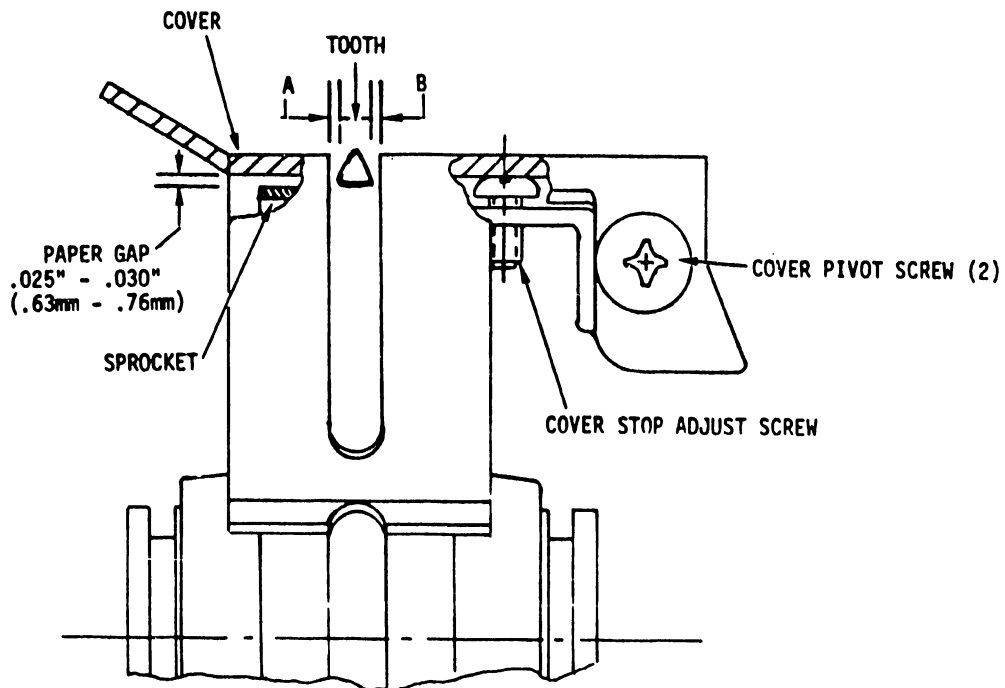

FIGURE 5-17 PAPER FEED SPROCKET ADJUSTMENTS

(b) Adjustment

- 1) Adjust cover height with locking stop screw. Move screw down until a gap of .025" - .030" gauge begins to pinch between cover and rubber of sprocket.
- 2) Adjust sprocket cover pivot screws (2) to center teeth. This must be done to both paper guide assembly covers. The pivot screws act as eccentrics to center the cover.

(c) Paper Feed Sprocket Removal

- 1) Remove right ribbon drive assembly (see Section 5.3.12).
- 2) Remove manual paper adjust shaft by pulling pin on left side of shaft, Figure 5-18.

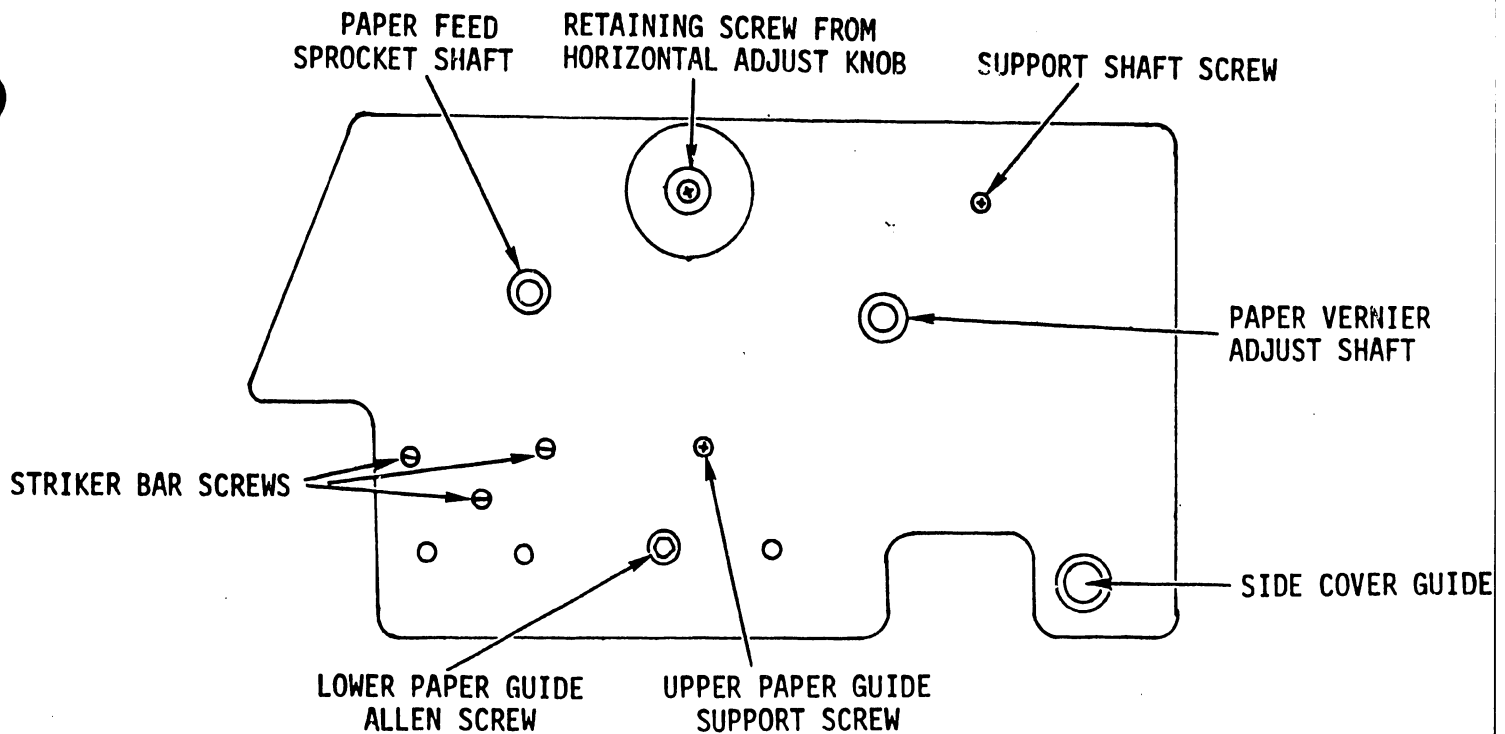

FIGURE 5-18 PAPER FEED SPROCKET REMOVAL AND REPLACEMENT

- 3) Remove retaining screw of horizontal adjusting knob and remove the knob by unscrewing it from the shaft.
- 4) Remove the right lower paper guide Allen screw, this causes the paper guide lock nut to fall out.
- 5) Remove the remaining screws which include three flathead striker plate support screws, a Phillips screw holding upper paper guide and another Phillips holding the support rod between the left and right side frames.
- 6) Slide the side frame to the right off the horizontal adjusting shaft, the side cover guide tube and the sprocket feed shaft.

CAUTION:

The lock knob unit contains a plastic insert beneath the screw shaft. To prevent marring of the shaft, do not lose this piece.

- 7) Remove the black spacer washer from the paper feed sprocket shaft, slide the feed sprocket and lock knob unit off the shafts.
- 8) When removing and replacing the molded drive sprocket and rubber assembly (part #279-5070-63) for any reason, insure that both the left and right sprocket teeth line-up on the splined shaft. Each sprocket has a molded rib on the inside hub which is the key for proper alignment and proper paper drive. When reassembling the paper feed sprocket assembly, follow the steps in paragraph 5.3.9(c) in reverse.

5.3.10 *VERNIER CLUTCH*

(a) Adjustment Check

By using the manual paper adjust knob, push the vernier clutch in and out. With the use of a feeler gauge check for a clearance of

.002" to .005" (.005 cm to .013 cm) between the idler shaft pulley flange and the side frame as shown on Figure 5-19. Also when the knob is released after paper advancement the vernier clutch should fully reengage.

(b) Adjustment

- 1) Remove the belt pulley on the paper feed sprocket shaft to gain access to the Allen set screw which secures the idler shaft pulley. Loosen set screw.
- 2) While pushing the paper adjust knob in all the way, push the idler shaft pulley against the side frame as close as possible and retighten Allen screw.

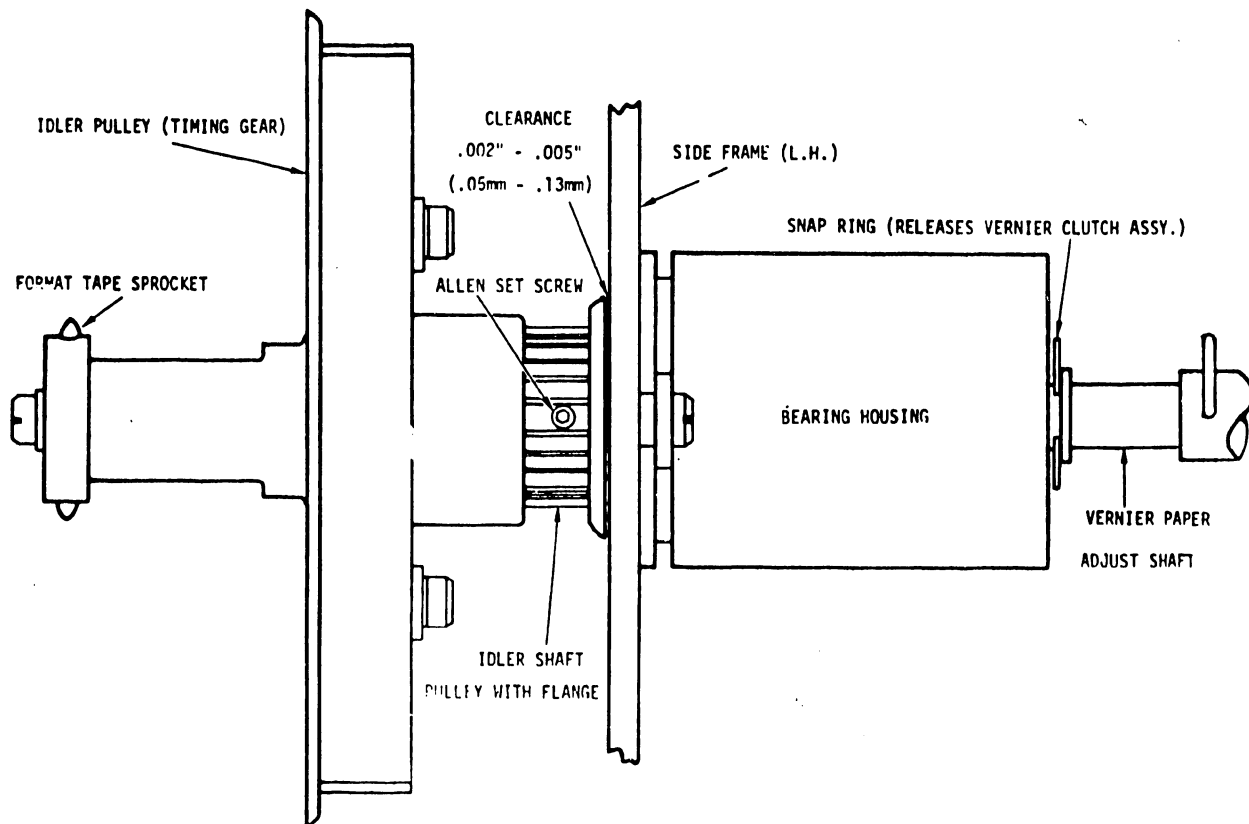

FIGURE 5-19 VERNIER CLUTCH ADJUSTMENTS

- 3) If clutch does not fully reengage after adjustment, loosen the spring collar (right side of vernier shaft) and compress spring more, however not enough to restrict full disengagement of clutch.

(c) For removal of the clutch, see belt removal and replacement (Section 5.3.13(c)).

5.3.11 VERTICAL FORMAT UNIT (VFU)

(a) Adjustment Check

- 1) The curve of the sprocket should be uniform (see Figure 5-20) and parallel with the curve of the housing allowing plenty of tooth height but not forcing the surface of the sprocket to interfere with the cover.

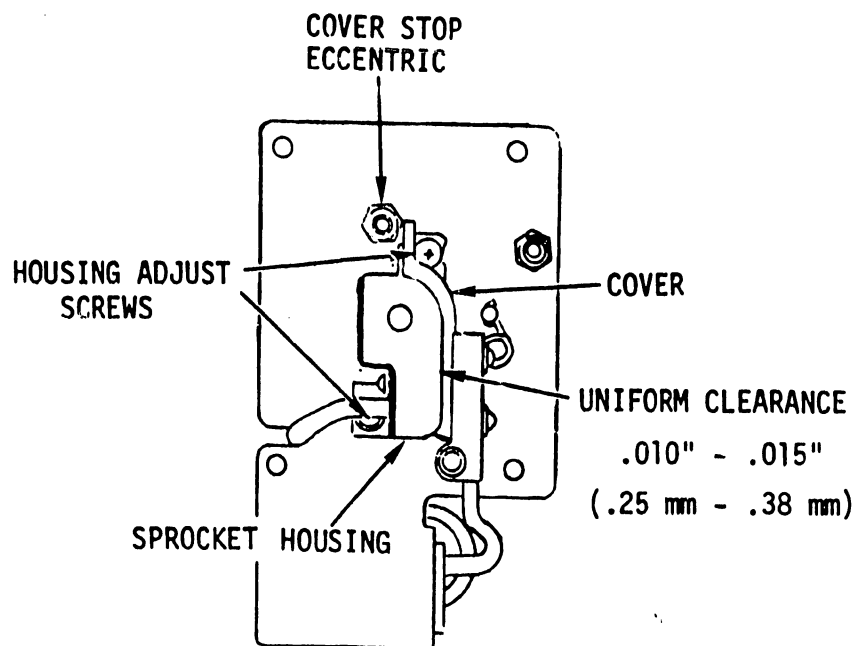

FIGURE 5-20 VERTICAL FORMAT UNIT ADJUSTMENTS

- 2) With the cover closed, there must be a .010" to .015" (.25 mm to .38 mm) uniform clearance between the cover and housing.
- 3) With the cover open and the tape well seated in the sprocket, the tape will be centered in the indented part of the housing.

- 4) The output of the phototransistor should be at least +4 volts on all three channels of the VFU. Connect scope to the following pins of the 6577 board to determine their amplitude (hold the Top Of Form switch down continuously):

Channel 2 (PEPE) M_1

Channel 5 (VTPE) R_1

Channel 7 (FFPE) P_1

- 5) The stepping motor and VFU should be in phase. Connect a scope probe (channel 1) to pin R_1 of the 6577 and another probe to pin S_2 . Trigger on channel 1. Key Top of Form continuously. Channel 1 of the scope is the output of channel 5 of the VFU and channel 2 of the scope is the 8th step signal (\overline{LFE}) from the motor circuit. The 8 step pulse should appear just left of center of the VFU signal. See Figure 5-21. If signals are incorrect proceed to adjustment section step 7.

(b) Adjustment

- 1) The sprocket and tape housing are separate parts, hence with cover open, loosen the two screws holding the housing (Figure 5-22). Move the housing so that the base of the sprocket is flush with the housing. See Figure 5-23 Rear View.
- 2) Adjust cover stop eccentric to set a gap of .010" - .015" (.25 mm - .38 mm) between the cover and housing (see Figure 5-20).
- 3) Adjust the tape side to side by turning the retaining screw (Figure 5-23). Course adjust by getting the tape somewhere between the two side guides. Fine align during the following steps.
- 4) Connect scope probes to pins P_1 and M_1 of the 6577 board. By doing this you will be looking at channels on either side of the tape.

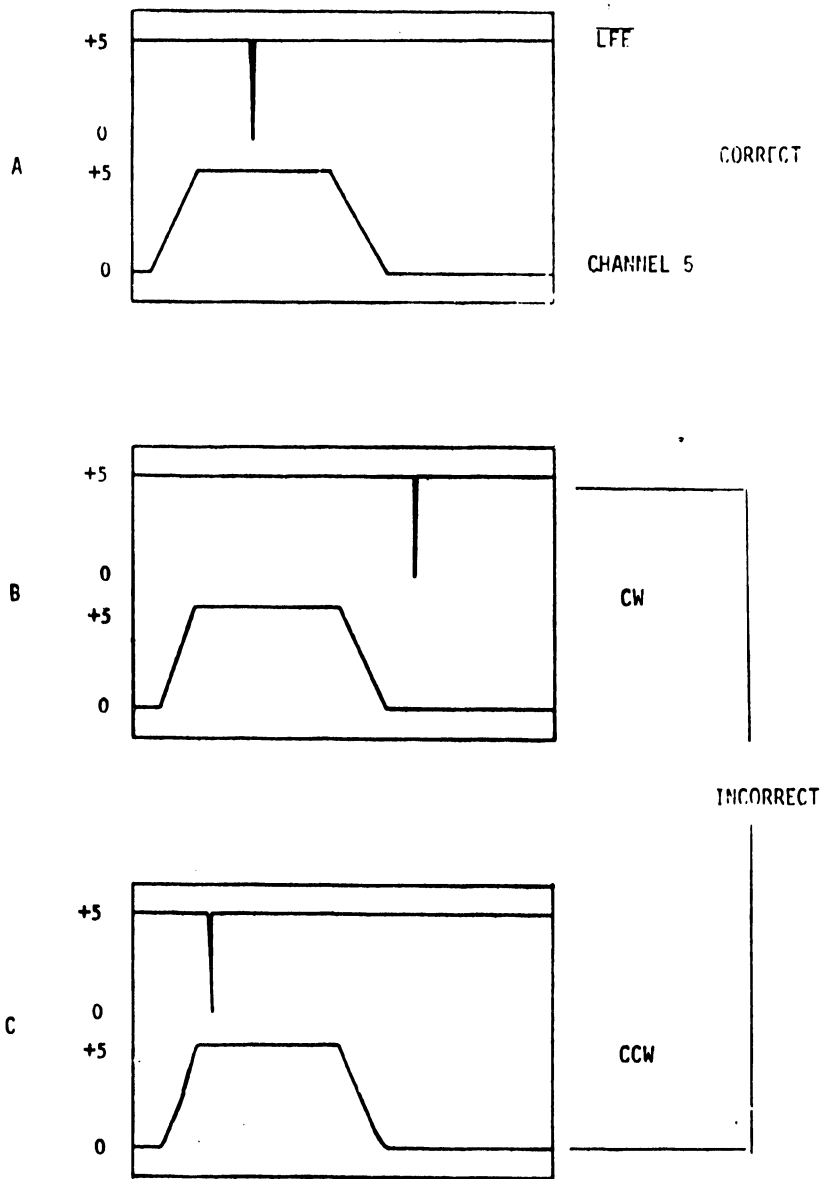

FIGURE 5-21 VFU AND STEPPER MOTOR PHASE CHECK

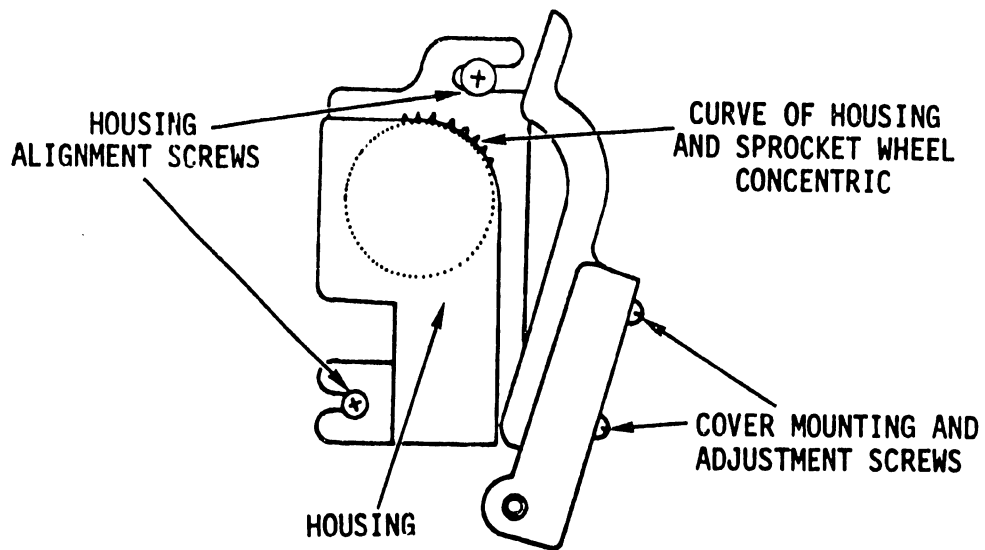

FIGURE 5-22 VERTICAL FORMAT HOUSING ADJUSTMENTS

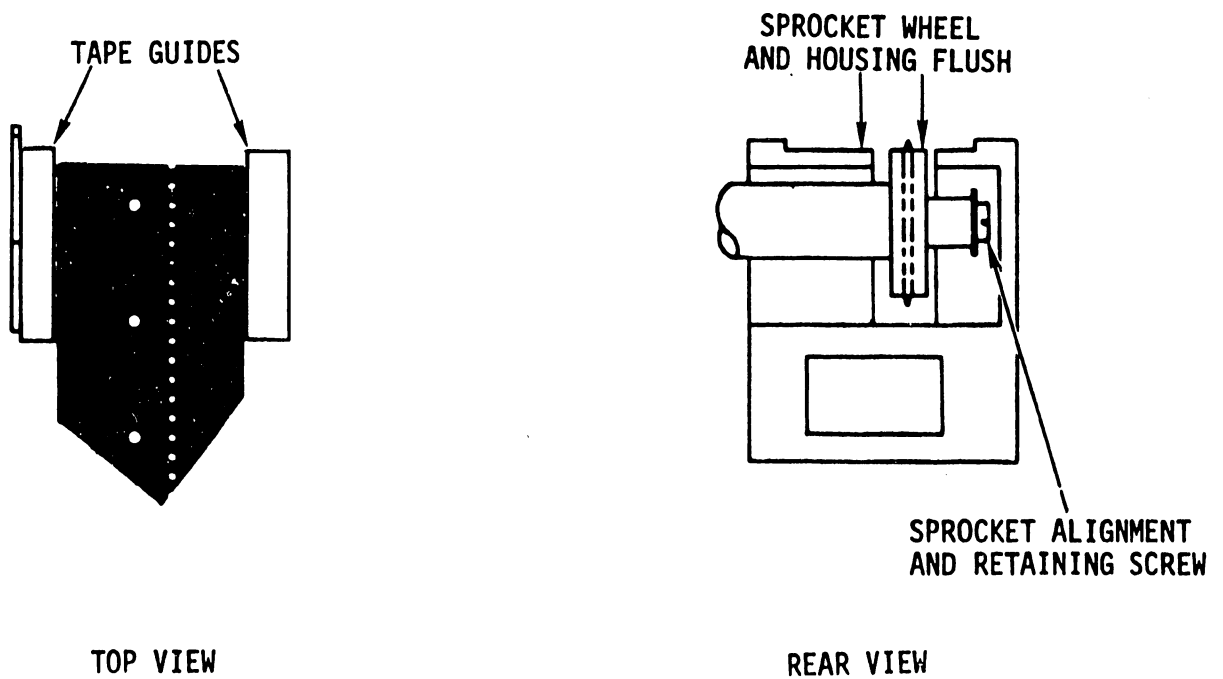

FIGURE 5-23 VERTICAL FORMAT SPROCKET ALIGNMENT

- 5) With cover closed and no tape in format unit, loosen the three cover mounting screws and move the cover up or down until +5 volts from both channels is attained while maintaining the clearances specified between housing and cover.
- 6) Replace the format tape and close the cover. With probes attached as in step 4, key Top of Form continuously. The signals should be at least +4 volts on each channel. If not, fine adjust the retaining screw of the sprocket (Figure 5-23). This moves the punched tape side to side.

NOTE:

The following steps are purely for phase adjustment. Do not perform this adjustment unless absolutely necessary.

- 7) Follow step (a) 5 to set up for this adjustment and to check phase.
- 8) If phase is off by more than a centimeter, a course alignment is necessary. Remove the belt between the stepping motor and timing gear (Vernier Clutch Assembly) and rotate the clutch assembly behind the VFU in desired direction several teeth and replace the belt. If the VFU signal is (channel 5) ahead of the 8th step pulse (Figure 5-21B), turn the Vernier Clutch Assembly clockwise. If the 8th step pulse is ahead of the VFU signal (Figure 5-21C) then turn the Vernier Clutch Assembly counterclockwise. If phase is off by a centimeter or less, loosening the motor retaining screw(s) (four on early model and one on late model) and then turning the motor in desired direction will correct phase error.

5.3.12 RIBBON DRIVE ASSEMBLY

(a) Adjustment Check

- 1) Solenoid Height - There should be a .005" (.13 mm) gap between the gear engagement arm and the motor shaft while the solenoid is deenergized. See Figure 5-24.

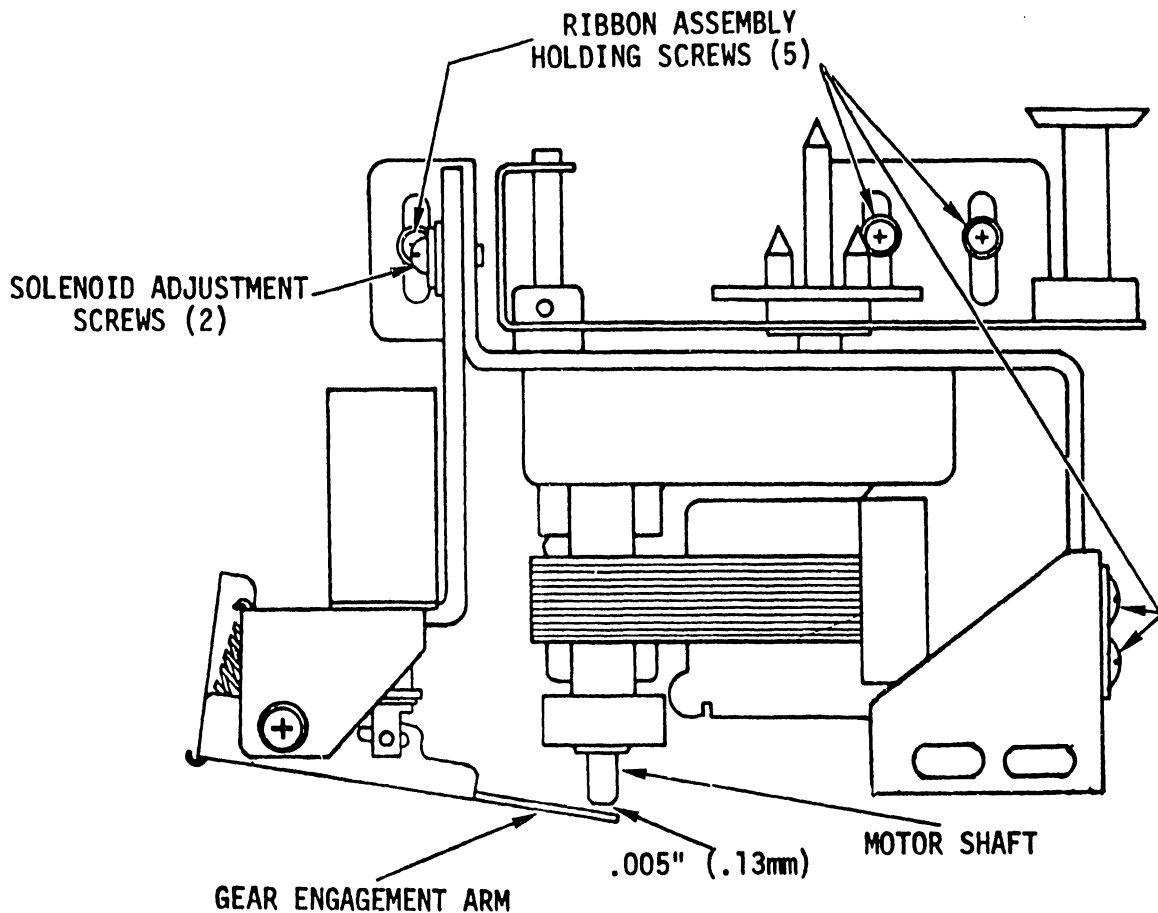

FIGURE 5-24 RIBBON DRIVE ASSEMBLY ADJUSTMENTS

- 2) Ribbon Tension Arms (Figure 5-25) - With the power off, wind one spool of ribbon manually several turns with your finger. After winding, release the spool and as ribbon tension arms come to rest, observe which one comes to rest last. The side which is pulling should stop last. For instance, if you were winding from the right spool and you suddenly released it, the tension arm of the right side will come to rest after the left tension arm.

CAUTION:

Do the following adjustment check with the power off.

- 3) Ribbon Height (Angle)

During the following procedure make sure the ribbon remains tight for an accurate test. Do this by manually winding the ribbon using the right spool.

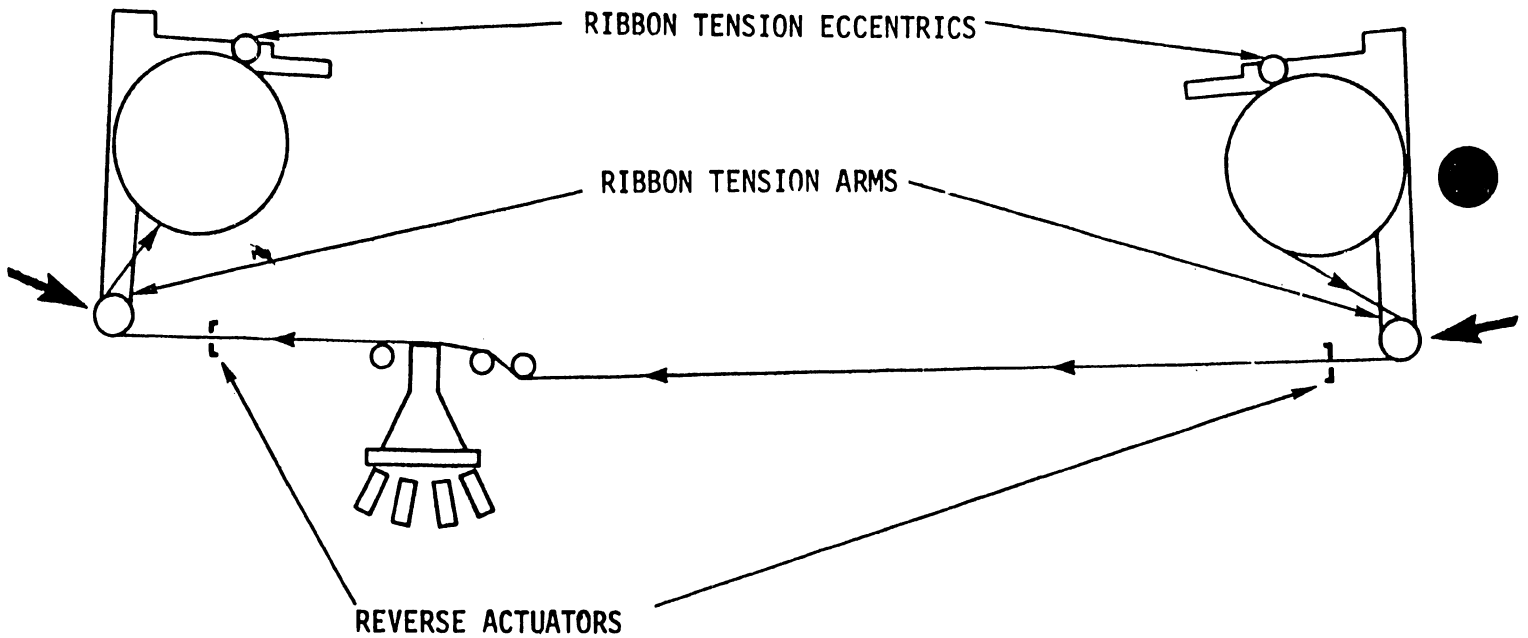

FIGURE 5-25 RIBBON TENSION ARMS (CHECKS AND ADJUSTMENTS)

- a) Move the carriage to the first character position (move carriage to photocoupler at first mark on timing fence). In this position there should be a distance of $.040''$ (1 mm) from the top of the print head bearing to the top of the ribbon. (See Figure 5-26.)
- b) Move the carriage to the 132nd character position (last timing mark on fence). In this position there should be a distance of $.710'' \pm .005''$ (18 mm $\pm .13$ mm) from the top of the print head bearing to the top of the ribbon.

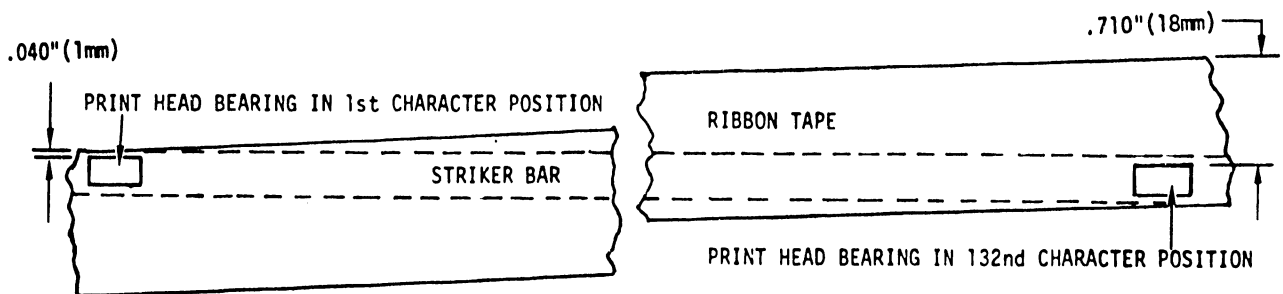

FIGURE 5-26 RIBBON HEIGHT AND ANGLE ADJUSTMENTS

- 4) Perpendicularity - Ribbon should be perpendicular to striker bar (distance to the bar from the bottom and top of the tape should be the same).

(c) Adjustment

- 1) Solenoid Height (Figure 5-24) - With power off, loosen the four holding screws on the solenoid bracket and move the solenoid in the desired direction to obtain the .005" (.13 mm) gap.
- 2) Ribbon Tension Arms (Figure 5-25) - If an arm comes to rest too early, adjust the ribbon eccentric stop on that assembly with the high dwell of the eccentric away from the ribbon spool.
- 3) Ribbon Height & Perpendicularity - Adjust the height by raising or lowering the entire ribbon feed assembly. There are holding screws on each assembly securing it on the side frame and base. Loosen these screws and slide the assembly up or down. Keep the ribbon taut during this adjustment and perpendicular to striker bar.

(d) Ribbon Feed Mechanism Removal and Replacement:

- 1) Remove ribbon.
- 2) Unplug connector from ribbon feed assembly.
- 3) Remove the five Phillips screws attaching the assembly to the side frame and base (Figure 5-24).
- 4) Reverse procedure to replace.
- 5) Readjust ribbon height and perpendicularity.

5.3.13 PAPER MOVEMENT BELTS

(a) Adjustment Check

- 1) Paper sprocket drive belt (front) with the belt depressed .18" (.45 cm), the scale should read 1 lb. (See Figure 5-27.)

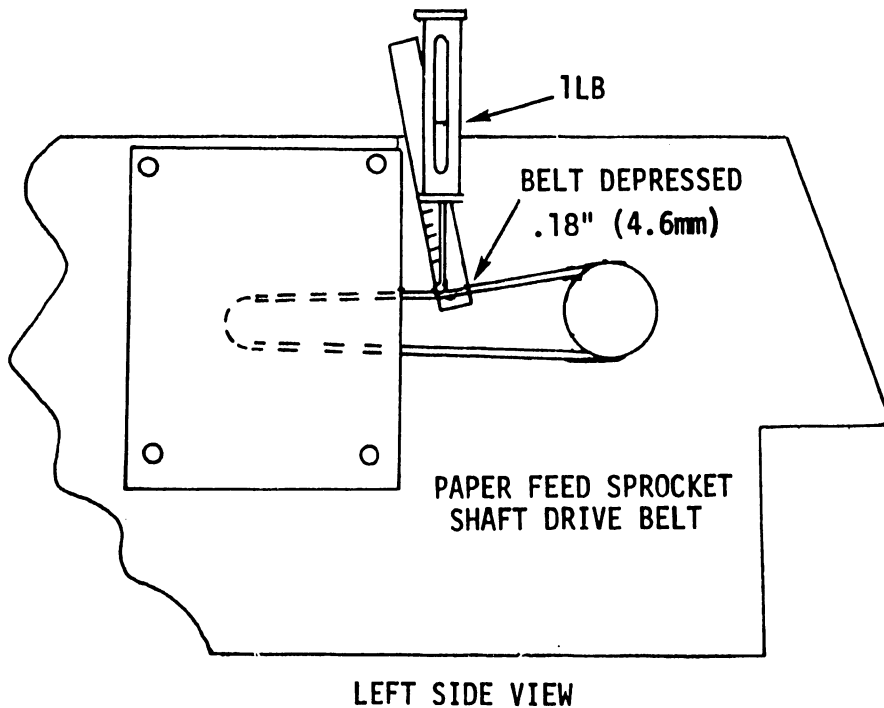

FIGURE 5-27 PAPER SPROCKET DRIVE BELT

- 2) Stepper Motor Timing Belt with the belt depressed .1" (.25 cm), the scale should read 1 lb. (See Figure 5-28.)
- (b) Adjustments
- 1) Paper sprocket drive belt - To tighten or loosen this belt, loosen the two screws holding the bearing housing to the side frame and move the bearing housing which in turn will move pulley and belt. After this has been done the stepper motor belt tension must be checked.
 - 2) Motor Belt - Loosen screws holding the motor bracket to the side frame. Move the motor in desired direction and tighten screws. Check VFU phasing adjustment [Section 5.3.11 (a)].

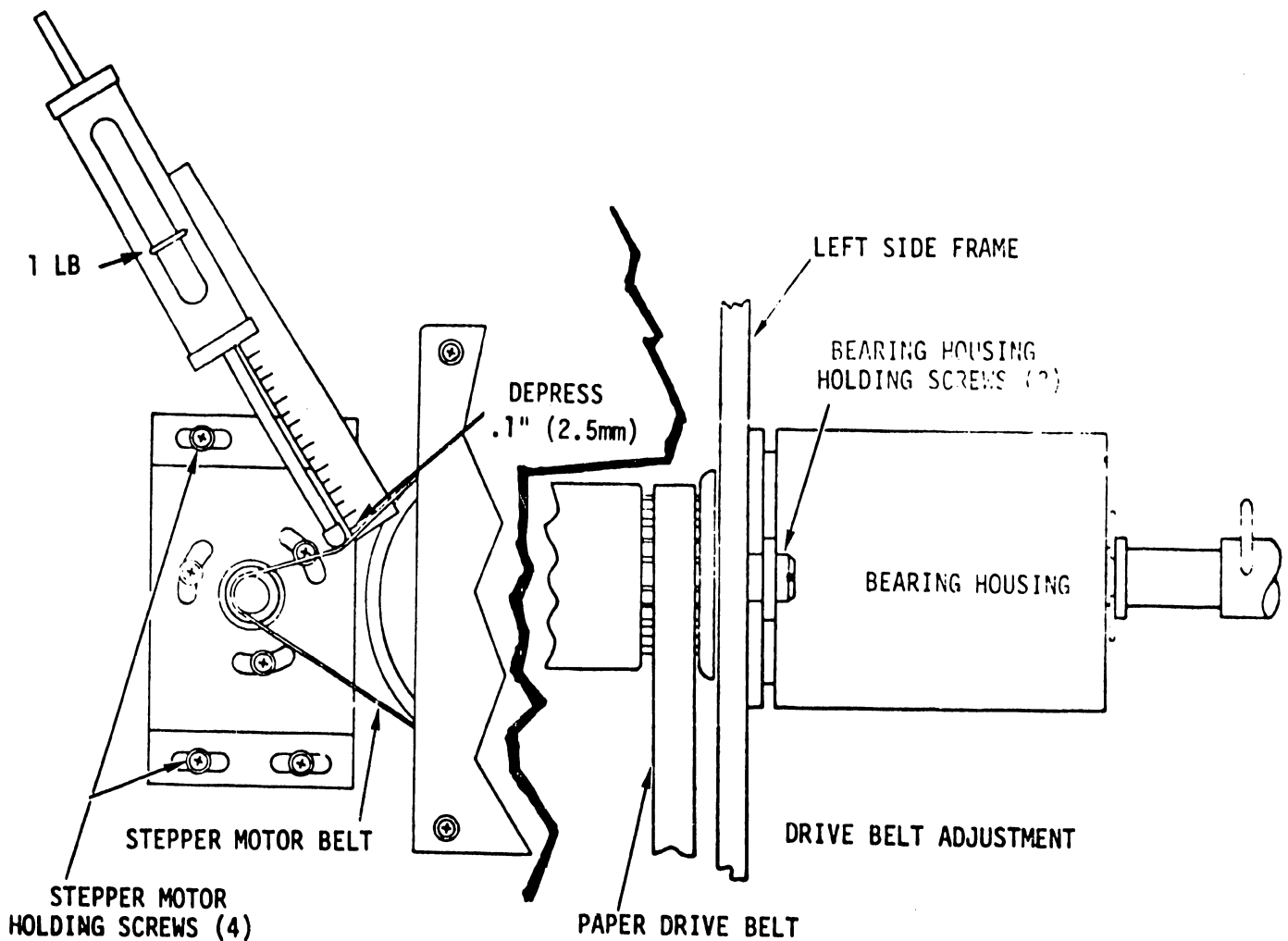

FIGURE 5-28 STEPPER MOTOR TIMING BELT ADJUSTMENT

(c) Stepper Motor Timing Drive Belt/Paper Sprocket Drive Belt - Removal and Replacement

- 1) Remove format tape. Remove format tape guide by removing the two left hand VFU mounting plate screws.
- 2) Remove the two screws securing the photosensor cover on the rear of the VFU housing.
- 3) Remove the two right hand VFU mounting plate screws.
- 4) Slide the VFU assembly up and toward the front of the unit to clear the VFU sprocket.

- 5) Remove the stepper timing gear belt. At this point of removal if it is necessary to remove the VERNIER CLUTCH ASSEMBLY (Timing Gear) remove snap-ring Part #651-1729 from end of bearing housing Part #461-3185 and the complete vernier clutch assembly will pull out.
- 6) To replace belt, reverse procedure.
- 7) Check belt tensions per Section 5.3.13 (a) and (b).
- 8) Check all VFU adjustments per Section 5.3.11.

5.3.14 TACHOMETER AND DRIVE MOTOR ADJUSTMENTS

(a) Adjustment Check

- 1) With tach and servo assembly removed from unit a force of .55 lbs. (250 grams) should deflect belt .05" (.12 cm). See Section (c) for removal. See Figure 5-29.
- 2) Drive Motor and Carriage Drive Belt - A force of 1 lb. should deflect belt .10" (.25 cm). See Figure 5-30.

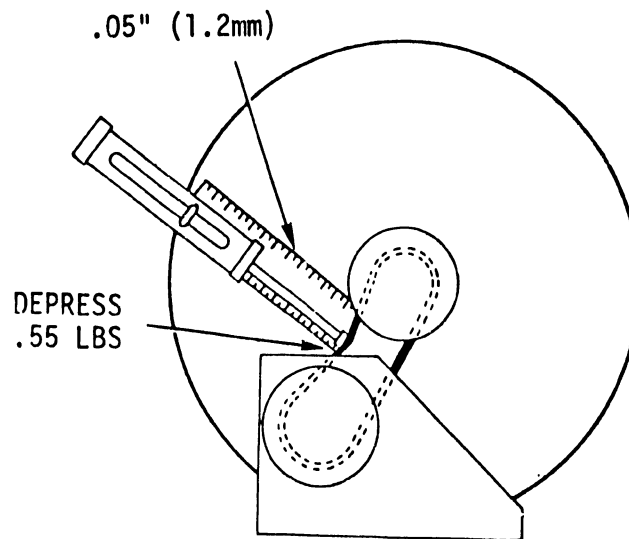

FIGURE 5-29 TACHOMETER BELT TENSION CHECK

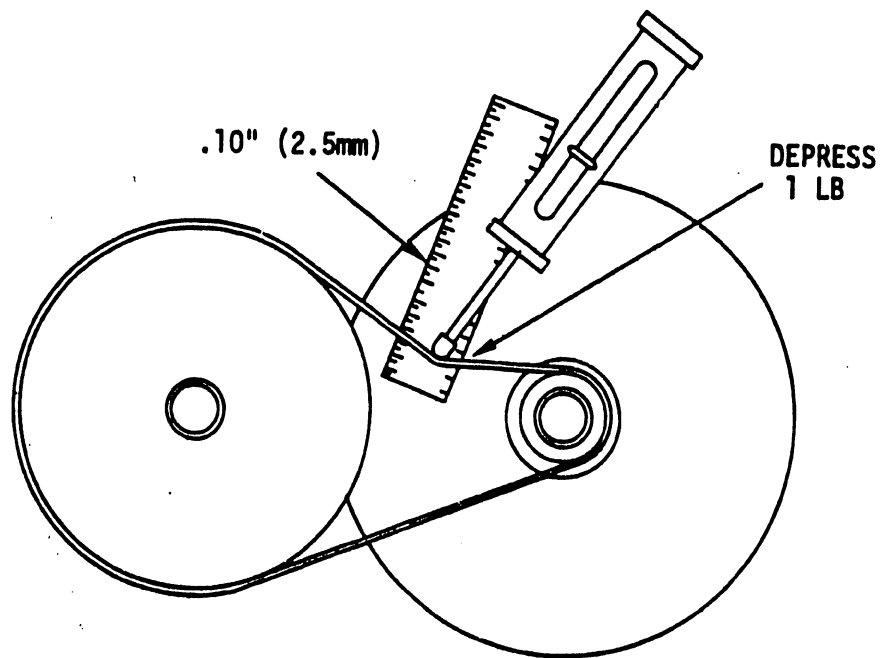

FIGURE 5-30 DRIVE MOTOR AND CARRIAGE DRIVE BELT CHECK

(b) Adjustment of Belt Tensions

- 1) Drive Motor and Tachometer Belt - Loosen two Phillips screws under tachometer and move it in desired direction as shown in Figure 5-31.
- 2) Drive Motor and Carriage Drive Belt - Loosen four Allen screws holding tachometer/servo assembly and move assembly in desired direction. See Figure 5-31.

(c) Removal and Replacement

- 1) Remove frame assembly per Section 5.3.16 to access carriage drive motor and tachometer assembly.
- 2) Disconnect J4 plug.
- 3) Remove four Allen screws that secure the drive motor and tachometer to printer base plate.

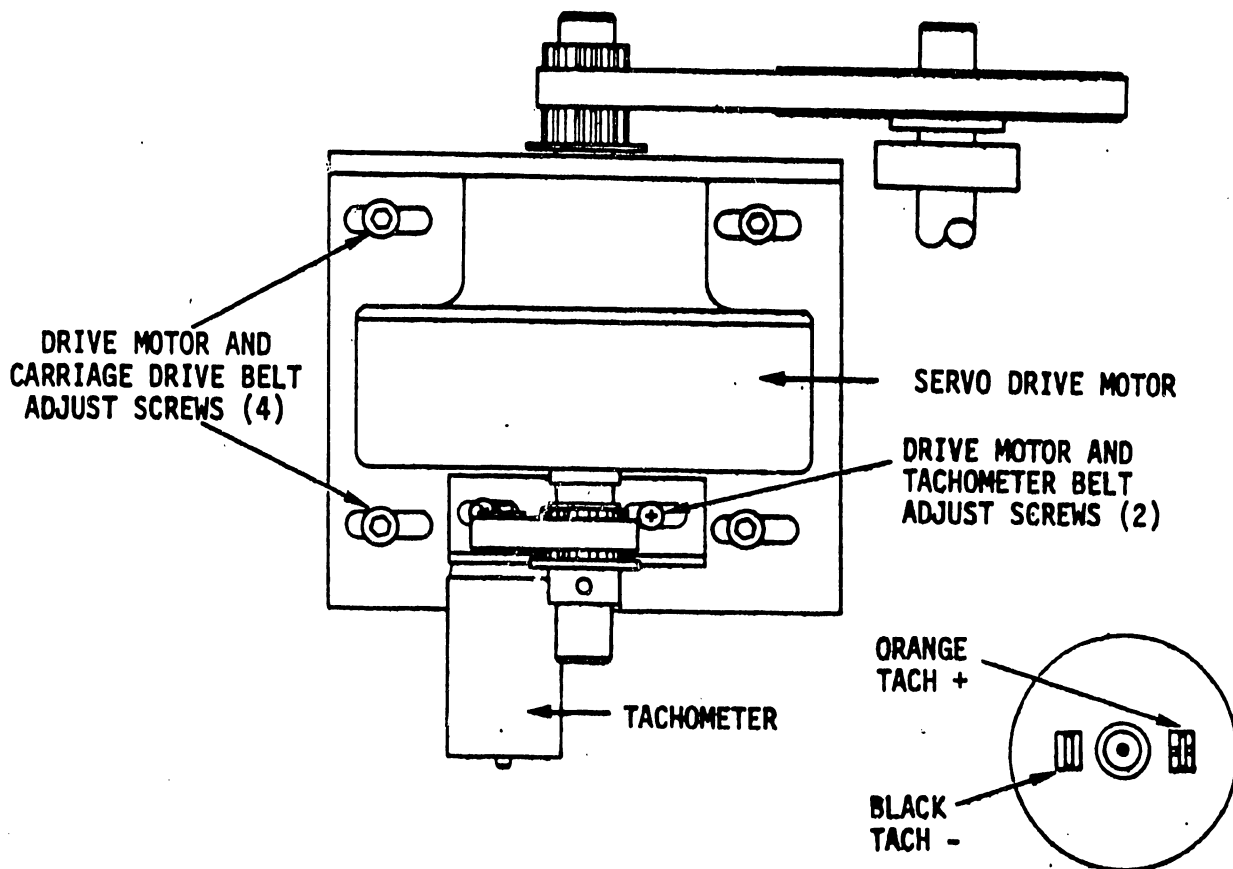

FIGURE 5-31 DRIVE MOTOR AND TACHOMETER BELT ADJUSTMENTS

- 4) To replace carriage drive motor and tachometer assembly, reverse procedure.
- 5) Readjust carriage drive shaft and bearing housing assembly drive belt.

5.3.15 CARRIAGE ASSEMBLY REMOVAL AND REPLACEMENT

- 1) Remove the ribbon from around the ribbon guides on the carriage assembly.
- 2) Remove the print head assembly per Section 5.3.5.
- 3) Pull the finger board for the photocoupler and disconnect the ribbon cable by removing screws A and B. Loosen and remove photocoupler. Do not scratch timing fence. See Figure 5-32.
- 4) Remove the rubber stop on the carriage shaft (2 screws - C & D early model)(1 screw late model).

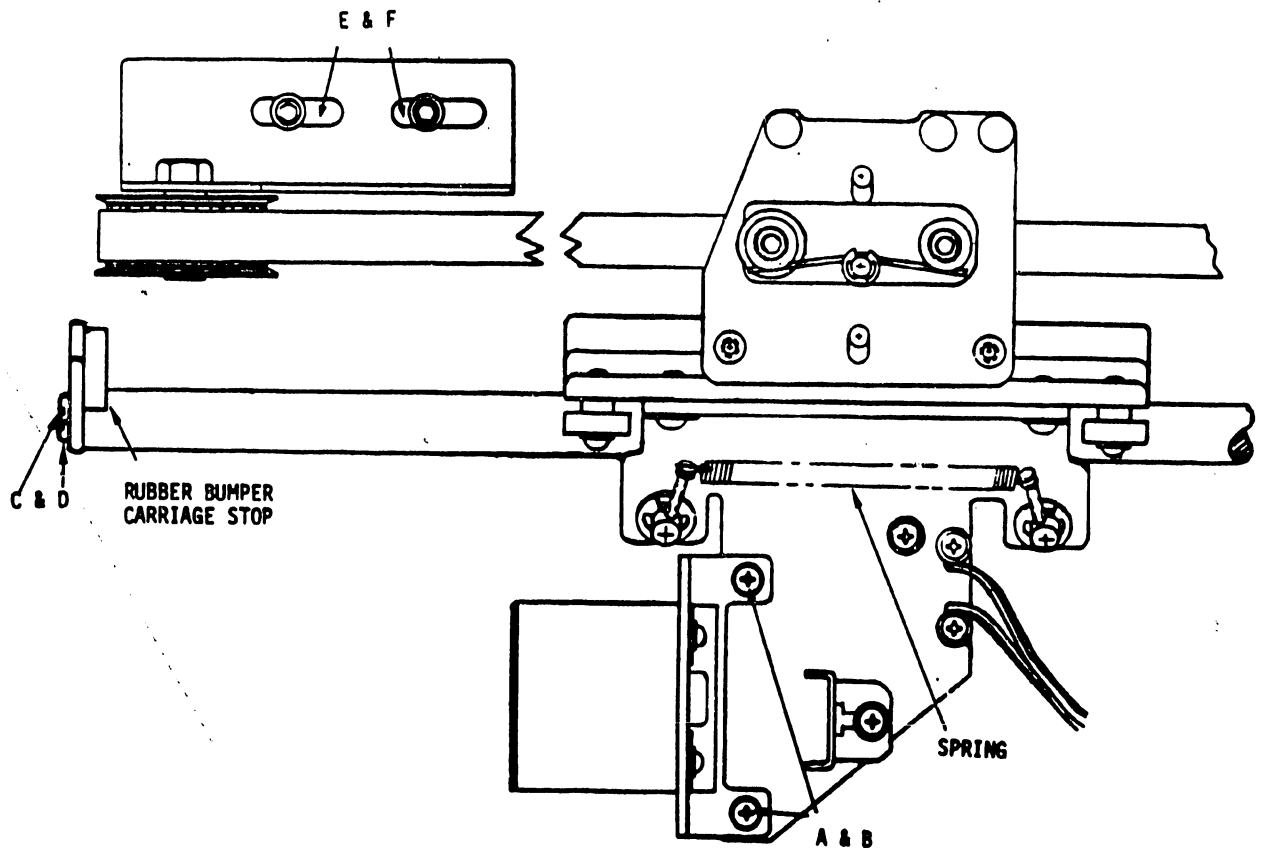

FIGURE 5-32 CARRIAGE ASSEMBLY REMOVAL AND REPLACEMENT

- 5) Remove the left main drive gear by removing Allen screws E and F.
- 6) Remove the main carriage belt from the right drive gear.
- 7) Hold on to carriage assembly and do not allow it to tip and gouge the timing fence while removing the spring. The spring releases the carriage from the carriage shaft.
- 8) Slide carriage to the left and off the carriage shaft.
- 9) Reverse procedure to reassemble. Realign photocoupler and maintain the tolerances as specified in Section 5.3.6.
- 10) Readjust belt tension for the carriage assembly.

5.3.16 FRAME ASSEMBLY REMOVAL AND REPLACEMENT

The frame assembly contains the paper movement sprockets, VFU, vernier clutch, ribbon drives and paper guide assembly. This section explains how to remove that section of the printer as a whole. Upon removing this assembly the remaining servo and carriage drive will continue to operate.

- 1) Remove right, left and rear cover. (Refer to Section 5.3.17.)
- 2) Remove the ribbon from its ribbon guides.
- 3) Back the print head as far from the striker bar as possible.
- 4) Unplug the following connectors:
 - (a) Stepper Motor
 - (b) Paper Out Microswitch
 - (c) Left and Right Hand Ribbon Drive Assemblies
 - (d) Vertical Format Unit
- 5) Remove the four Phillips screws holding the frame assembly to the casting. They are located (2) on each side of the striker bar. See Figure 5-33.
- 6) Remove the screws which attach the ribbon drive assemblies to the baseplate (2 on each side).
- 7) Remove the screw from the left side frame bracket attaching it to the electronic chassis (located beneath stepper motor).
- 8) Remove the two screws attaching the resistor board bracket to the right side frame.
- 9) Remove frame assembly carefully.
- 10) Reverse procedure to replace.

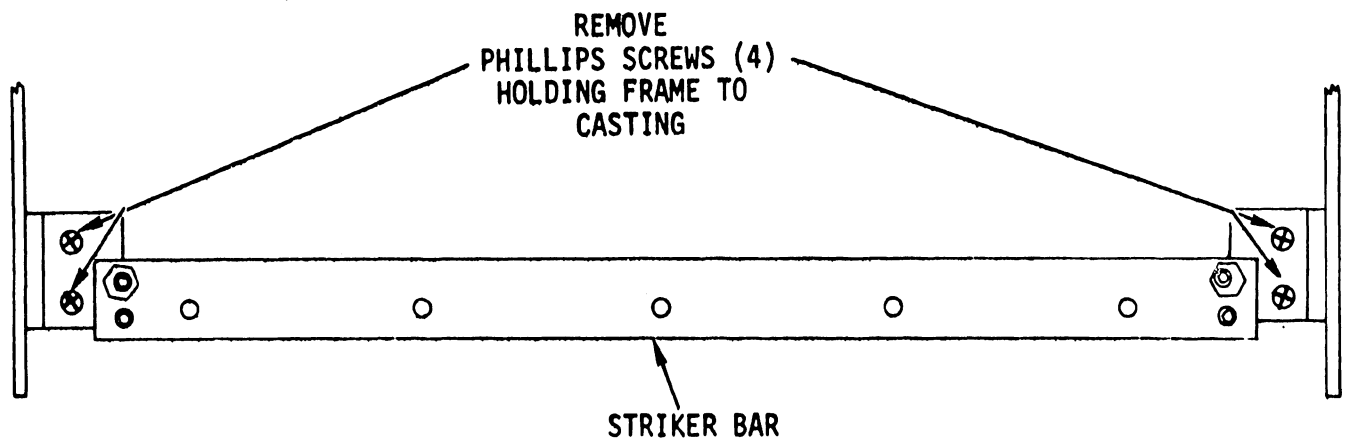

FIGURE 5-33 FRAME ASSEMBLY REMOVAL AND REPLACEMENT

5.3.17 COVER REMOVAL AND REPLACEMENT

- 1) The left and right covers are detachable by sliding them completely from the guide tubes. However, it may be necessary to unplug the connector of the control panel from the right hand cover.
- 2) The rear cover is removed by lifting from the bottom straight up and detaching the ground lead.
- 3) The front cover is removed by lifting it straight up while it is closed. This will lift it from its pivot. Then detach the ground lead.

5.3.18 CARRIAGE GUIDE SHAFT REMOVAL AND REPLACEMENT

If it becomes necessary to replace a carriage guide shaft on an early model printer, access to the 5 Phillips screws securing the guide shaft is restricted because no access holes were cut in the bottom pan assembly. Remove the electronics chassis and the 5 Allen screws securing the base casting to the frame. Remove the 4 Phillips screws mounting the ribbon assembly to the frame and tilt the base casting back to expose the carriage guide shaft mounting screws.

The new guide shaft must be mounted with the bar extended further to the left side of the casting. Install a new bumper assembly (WL# 451-4332) on the end of the shaft (1 screw). The replacement shaft may not seat identical to the old shaft. The striker bar must be adjusted to compensate for this difference.

SECTION

6

MAIN-

TENANCE

SECTION 6 MAINTENANCE

6.1 INTRODUCTION

This section of the manual consists of three sections: diagnostics, preventive maintenance and troubleshooting.

The diagnostics section contains a description, operating procedures and sample diagnostic programs to be run by the companion computer 2200 on the Model 72 Printer. The diagnostic programs are written to aid the user in the checkout of equipment and to assure sustained quality of character printing.

The preventive maintenance section will amplify Section 5 (Adjustments, Removal and Replacement) by directing the user to the more frequent problems solved by inspection (visual checks) such as cleaning, wear, adjustments and lubrication.

Troubleshooting tables are available to aid in finding the cause and the solution to operating problems. The tables commence with the most common and basic faults and progress to the less frequent and more complex faults.

6.2 DIAGNOSTICS

The Model 72 Matrix Printer uses two tape diagnostic programs. A short program version that will quickly check the performance of the printer and a long version for complete check-out. The longer version is the same diagnostic used in production as a burn-in character quality check.

6.2.1 LONG VERSION DIAGNOSTIC (BLOCK 1 OF TAPE)

1. Load first block of tape into memory.
2. Key CLEAR EXECUTE, LOAD EXECUTE and RUN EXECUTE.
3. The CRT will have the following printout:

TABLE 1

	SF KEY 0.1 CLEAR TEST
	SF KEY 2 LPO TEST
	SF KEY 15 COMPLETE TEST
RUN AND CONTINUE	RUN AND STOP
SF KEY 3 VERTICAL TABS	SF KEY 9 LINE FEEDS
SF KEY 4 SINGLE CHARACTERS	SF KEY 10 VERTICAL TABS
SF KEY 5 RANDOM BLOCKS	SF KEY 11 EXPANDED CHARACTERS
SF KEY 6 132 CHARACTERS	SF KEY 12 132 CHARACTERS
SF KEY 7 EXPANDED CHARACTERS	SF KEY 13 ALARM
SF KEY 8 'TUIHZ...' EXPANDED	SF KEY 14 SINGLE CHARACTERS
	SF KEY 16 FORM FEED

6.2.2 TEST FUNCTION DESCRIPTIONS FOR MODEL 72
(DISPLAYED ON CRT)

1. SF KEY 01 - CLEAR TEST
Will clear the data buffer (memory) of the 72 by requesting a delete code.
2. SF KEY 02 - LPO TEST
Will check 72 to see if LPO option is installed. If option is installed a line will be printed on the 72 with an underscore.
3. SF KEY 15 - COMPLETE TEST
Will check alignment of VFU and all functions of printer with a character quality test.
4. SF KEY 03 - VERTICAL TAB
Will check punched tape for proper vertical tab length and then continue with complete test.
5. SF KEY 04 - SINGLE CHARACTERS
Will print one (1) character per line to check the servo circuit breaker against tripping due to overload. A timing adjustment is required if breaker trips.
6. SF KEY 05 - RANDOM BLOCKS
Performs a print quality test by selecting random blocks of characters.

7. SF KEY 06 - 132 CHARACTERS
Test insures that a total of 132 characters are printed on a single line.
8. SF KEY 07 - EXPANDED PRINT
Checks upper and lower case characters in expanded form print.
9. SF KEY 08 - "TUIHZ"...EXPANDED
Printing of a specific pattern of characters.
10. SF KEY 09 - LINE FEEDS
Will execute three (3) consecutive line feeds.
11. SF KEY 10 - VERTICAL TABS
Executes nine (9) consecutive Vertical Tabs and then stops.
12. SF KEY 11 - EXPANDED CHARACTERS
Will print in expanded form continuously. Maximum of 60 characters per line.
13. SF KEY 12 - 132 CHARACTERS
Repeats the same check that (SF KEY 06) provides that 132 characters are printed.
14. SF KEY 13 - ALARM
Will cause the bell alarm to ring three times.
15. SF KEY 14 - SINGLE CHARACTERS
Will print one (1) character per line for six lines. This test results in a critical timing check required by the servo carriage control system.
16. SF KEY 16 - FORM FEED
Will execute consecutive form feed checks for proper page length.

H1QJKGHJKGHJKGHJK1. THIS IS THE FIRST LINE OF THE PRINT OUT

6. THIS IS THE SIXTH LINE.
7. VERTICAL TAB STARTS FROM THIS LINE

12 . VERTICAL TAB . HEX(0B)

LONG VERSION DIAGNOSTIC

13 . VERTICAL TAB . HEX(0B)

24 . VERTICAL TAB . HEX(0B)

30 . VERTICAL TAB . HEX(0B)

36 . VERTICAL TAB . HEX(0B)

42 . VERTICAL TAB . HEX(0B)

48 . VERTICAL TAB . HEX(0B)

54 . VERTICAL TAB . HEX(0B)
55. THE NEXT TEST IS FOR THE LINE FEED CODE HEX(0A)

59. THIS LINE SHOULD BE PRINTED BEFORE END OF DOCUMENT

1. -----THIS SHOULD BE THE FIRST LINE AFTER END OF DOCUMENT.-----

A
B
C
D
E
F

ABCDEFGHIJKLMNOPQRSTUVWXYZ1234567890-!@#%&*()-+/:;? . abcdefghijklmnopqrstuvwxyz!@#%&*()-+1234567890-!/:;? . ABCDEFGHIJKLMNOP
 TTTT=====SSSSwww 1 1 1 iMMMM : : : : : 1 1 1 1 1 1 1 1 1 TTT==SSww i iMM : : : : 1 1 1 1 BERNINI!
 ABCDEFGHIJKLMNOPQRSTUVWXYZ1234567890-!@#%&*()-+/:;? . abcdefghijklmnopqrstuvwxyz!@#%&*()-+1234567890-!/:;? . ABCDEFGHIJKLMNOP
 TTTT=====SSSSwww 1 1 1 iMMMM : : : : : 1 1 1 1 1 1 1 1 1 TTT==SSww i iMM : : : : 1 1 1 1 BERNINI!
 ABCDEFGHIJKLMNOPQRSTUVWXYZ1234567890-!@#%&*()-+/:;? . abcdefghijklmnopqrstuvwxyz!@#%&*()-+1234567890-!/:;? . ABCDEFGHIJKLMNOP
 TTTT=====SSSSwww 1 1 1 iMMMM : : : : : 1 1 1 1 1 1 1 1 1 TTT==SSww i iMM : : : : 1 1 1 1 BERNINI!
 ABCDEFGHIJKLMNOPQRSTUVWXYZ1234567890-!@#%&*()-+/:;? . abcdefghijklmnopqrstuvwxyz!@#%&*()-+1234567890-!/:;? . ABCDEFGHIJKLMNOP
 TTTT=====SSSSwww 1 1 1 iMMMM : : : : : 1 1 1 1 1 1 1 1 1 TTT==SSww i iMM : : : : 1 1 1 1 BERNINI!
 ABCDEFGHIJKLMNOPQRSTUVWXYZ1234567890-!@#%&*()-+/:;? . abcdefghijklmnopqrstuvwxyz!@#%&*()-+1234567890-!/:;? . ABCDEFGHIJKLMNOP
 TTTT=====SSSSwww 1 1 1 iMMMM : : : : : 1 1 1 1 1 1 1 1 1 TTT==SSww i iMM : : : : 1 1 1 1 BERNINI!
 ABCDEFGHIJKLMNOPQRSTUVWXYZ1234567890-!@#%&*()-+/:;? . abcdefghijklmnopqrstuvwxyz!@#%&*()-+1234567890-!/:;? . ABCDEFGHIJKLMNOP
 TTTT=====SSSSwww 1 1 1 iMMMM : : : : : 1 1 1 1 1 1 1 1 1 TTT==SSww i iMM : : : : 1 1 1 1 BERNINI!
 ABCDEFGHIJKLMNOPQRSTUVWXYZ1234567890-!@#%&*()-+/:;? . abcdefghijklmnopqrstuvwxyz!@#%&*()-+1234567890-!/:;? . ABCDEFGHIJKLMNOP
 TTTT=====SSSSwww 1 1 1 iMMMM : : : : : 1 1 1 1 1 1 1 1 1 TTT==SSww i iMM : : : : 1 1 1 1 BERNINI!
 ASAB
 AB
 AB
 AB
 AB

6-5

37. VERTICAL TAB. HEX(0B)

- 48. 10 LINE-FEEDS. HEX(0A)
- 50. YOU SHOULD HEAR THE BELL SOUND THREE TIMES.
- 51. AFTER THIS LINE IS PRINTED THERE SHOULD BE A FORM-FEED

10 REM PRTO10A 00-00 6/20/75 12002
 15Z=0
 20 DIM T(11),C(5),S(5),A(6),C2(26)

21 SELECT PRINT 005
 22 PRINT HEX(0103)
 23 PRINT TAB(20):"SF KEY 0.1 CLEAR TEST"
 24 PRINT TAB(20):"SF KEY 2 LPD TEST"
 25 PRINT TAB(20):"SF KEY 15 COMPLETE TEST"
 26 PRINT "RUN AND CONTINUE" "RUN AND STOP"
 27 PRINT "SF KEY 3 VERTICAL TABS" "SF KEY 9 LINE FEEDS"
 28 PRINT "SF KEY 4 SINGLE CHARACTERS" "SF KEY 10 VERTICAL TABS"
 29 PRINT "SF KEY 5 RANDOM BLOCKS" "SF KEY 11 EXPANDED CHARACTERS"
 30 PRINT "SF KEY 6 132 CHARACTERS" "SF KEY 12 132 CHARACTERS"
 31 PRINT "SF KEY 7 EXPANDED CHARACTERS" "SF KEY 13 ALARM"
 32 PRINT "SF KEY 8 'TUIHZ...' EXPANDED" "SF KEY 14 SINGLE CHARACTERS"
 33 PRINT TAB(32):"SF KEY 16 FORM FEED"
 34 SELECT PRINT 215(132)
 35 STOP

36 SELECT PRINT 215(132)
 40 PRINT "1. THIS IS THE FIRST LINE OF THE PRINT OUT"
 50 PRINT :PRINT :PRINT :PRINT :PRINT "6. THIS IS THE SIXTH LINE."
 60 PRINT "7. VERTICAL TAB STARTS FROM THIS LINE"
 70 FOR I=1 TO 8
 80 N=(I+I)*6
 90 PRINT HEX(0B):PRINT N: ". VERTICAL TAB . HEX(0B)"
 100 NEXT I
 105 IF Z=1 THEN 1320
 110 PRINT "55. THE NEXT TEST IS FOR THE LINE FEED CODE HEX(0A)"
 120 FOR I=1 TO 3
 130 PRINT HEX(0A)
 140 NEXT I
 145 IF Z=1 THEN 1320
 150 PRINT "59. THIS LINE SHOULD BE PRINTED BEFORE END OF DOCUMENT"
 160 PRINT "1.-----THIS SHOULD BE THE FIRST LINE AFTER END OF DOCUMENT.-----"

170 A="HEX(4100004200004300004400004500004600)"
 180 PRINT A#
 185 IF Z=1 THEN 1320
 190 FOR I=1 TO 10
 200 PRINT "ABCDEFGHIJKLMN0PQRSTUVWXYZ1234567890--!@#%&*()-+/:./?:.abcdefghijklmnopqrstuvwxyz!@#%&*()-+1234567890--!/:.:? .ABCDEFGHIJKLMN0P"
 210 PRINT HEX(0E):PRINT "TTTT===555www1111111111111111TT==55www1111111111111111BBBNNN"
 220 NEXT I
 230 FOR I=1 TO 264
 240 PRINT "AB":
 250 NEXT I

260 PRINT HEX(0B):PRINT "37. VERTICAL TAB. HEX(0B)"
 270 FOR I=1 TO 10
 280 PRINT HEX(0A)
 290 NEXT I
 300 PRINT "48. 10 LINE-FEEDS. HEX(0A)"
 310 PRINT "THIS LINE SHOULD NOT BE PRINTED. UNLESS THE PRINTER IS NOT RESPONDING TO THE DELETE CODE HEX(7F)":HEX(7F)
 320 PRINT "50. YOU SHOULD HEAR THE BELL SOUND THREE TIMES"
 330 PRINT HEX(07)
 340 FOR D= 1 TO 300
 350 NEXT D
 360 PRINT HEX(07)
 370 FOR D= 1 TO 300
 380 NEXT D
 390 PRINT HEX(07)

8-9

```

395 IF Z=1 THEN 1320
400PRINT "51. AFTER THIS LINE IS PRINTED THERE SHOULD BE A FORM-FEED"
410PRINT HEX(OC)
420 N=1
430 P3=1
440 FOR I=1 TO 26
450 BIN(STR(I*(1).1))=INT(RND(1)*94+33)
460 C2*(I)=STR(I*(1).1)
470 STR(I*(1).2)=STR(I*(1).1)
480 MAT COPY I*(1) TO C1*(1)<P3.5>
490 P3=P3+5
500 NEXT I
510 FOR I= 1 TO 26
520 PRINT TAB(I*5-5):C2*(I):
530 NEXT I
540 FOR I=1 TO 5
550 FOR J=1 TO 5
560 PRINT C1*(J):
570 NEXT J
580 NEXT I
590 PRINT HEX(OD)
600 N=N+1
610 IF N<10THEN 430
620 PRINT HEX(OC)
630 P3=1:N=33:P4=1
640 FOR I=1 TO 130
650 IF N <= 126 THEN 670
660 N = 33
670 BIN(I*(1))=N
680 N=N+1
690 MAT COPY I*(1) TO C*(1)<P3.1>
700 P3=P3+1
710 NEXT I
720 FOR I=1 TO 95
730 FOR J=1 TO 5
740 IF P4=2THEN 770
750 PRINT C*(J):
760 GOTO 780
770 PRINT HEX(OE):C*(J):
780 NEXT J
790 T*(1) =STR(C*(5).26.1)
800 MAT COPY C*(1)<1.129> TO C1*(1)<2.129>
810 MAT COPY T*(1)<1.1>TO C1*(1)<1.1>
820 MAT COPY C1*(1) TO C*(1)
830 NEXT I
835IF Z=1 THEN 1320
840 IF P4>1 THEN 870
850 P4=2
860 GOTO 720
870 PRINT HEX(OC)
880 A*="TUIHZ-/.#+/TUIHZ-/.#+/TUIHZ-/.#+/TUIHZ-/.#+/TUIHZ-/.#+/"/
890 FOR I=1 TO 25
900 PRINT HEX(OE):A*
910 NEXT I
920 FOR I=1 TO 25
930 PRINT A*:A*
940 NEXT I
945GOTO 21
1180 DEFFN'02
1185SELECT PRINT 215(132)

```

```

1140REM -----LPD TEST
1195 FOR I=1 TO 15
1200PRINT HEX(09E6A0D4EBE9F3A0D5EE9F4A0CB1F3A0D4EBE5A0CCD0CFA0CFF0F4E9EFEEA0D4EBE5F3E5A0D7EFF2E4F3A0D7E9E0E0A0C2E5A0D9F5E4E0D0E0E0
EEEE5E4)
1210 NEXT I
1215 STOP
1250DEFN'00
1260SELECT PRINT #15
1270PRINT "HJGJKGHJKGHJKGHJKGHJK"
1290STOP
1290DEFN'01 "CONTINUE"
1300PRINT HEX(0D)
1310GOTO 21
1320Z=0
1325GOTO 21
1330DEFN'10
1340REM -----VERTICAL TABS
1345SELECT PRINT 215(132)
1350Z=1
1350GOTO 60
1370DEFN'09
1380REM -----LINE FEEDS
1385SELECT PRINT 215(132)
1390Z=1
1400GOTO 110
1410DEFN'12
1420REM -----CHARACTERS
1425SELECT PRINT 215(132)
1430Z=1
1440GOTO 630
1450DEFN'13
1460REM -----ALARM
1465SELECT PRINT 215(132)
1470Z=1
1480GOTO 320
1490DEFN'03
1500GOTO 60
1510DEFN'04
1520GOTO 160
1530DEFN'05
1540GOTO 420
1570DEFN'06
1580 GOTO 630
1590DEFN'07
1592P3=1
1593N=33:P4=2
1600GOTO 640
1610DEFN'08
1620GOTO 880
1630DEFN'11
1640REM -----EXPANDED CHARACTERS
1650SELECT PRINT 215(132)
1660Z=1
1661P3=1:N=33
1665P4=2
1670GOTO 640
1680DEFN'14
1690REM -----SINGLE CHAR.
1700SELECT PRINT 215(132)
1710Z=1

```

1720GOTO 170
1730DEFFN' 15
1740GOTO 39
1750DEFFN' 16
1760PRINT HEX.(OC)
1770GOTO 21

6.2.3 SHORT VERSION DIAGNOSTIC

1. Perform the following functions in order shown:

Key CLEAR EXECUTE

Key LOAD EXECUTE

Key RUN EXECUTE

2. The CRT will display the following readout:

LIST AVAILABLE FUNCTION SF00

DIAGNOSTIC TEST FOR 66 LINES/PAGE FORM SF01

SPACES FOR ADJUSTMENTS SF15

CHARACTER QUALITY TEST SF14

- a) LIST AVAILABLE FUNCTIONS SF00
will list available functions.

- b) DIAGNOSTIC TEST FOR 66 LINES/PAGE FORM SF0
Complete diagnostic checkout.

- c) SPACES FOR ADJUSTMENTS SF15
This test will cause spaces to be printed (printing solenoids disabled) as timing can be checked and/or adjusted.

- d) CHARACTER QUALITY TEST SF14
This test will print regular and expanded characters for quality check.

1. THIS IS THE FIRST LINE OF THE PRINT OUT

6. THIS IS THE SIXTH LINE

7. VERTICAL TAB STARTS FROM THIS LINE

SHORT VERSION DIAGNOSTIC

12. VERTICAL TAB. HEX(OB)

18. VERTICAL TAB. HEX(OB)

24. VERTICAL TAB. HEX(OB)

30. VERTICAL TAB. HEX(OB)

36. VERTICAL TAB. HEX(OB)

42. VERTICAL TAB. HEX(OB)

48. VERTICAL TAB. HEX(OB)

54. VERTICAL TAB. HEX(OB)

55. THE NEXT TEST IS FOR THE LINE FEED CODE HEX(OA)

59. THIS LINE SHOULD BE PRINTED BEFORE END OF DOCUMENT

```

10DIM B#64
20B#="ABCDEFGHIJKLLMNOPQRSTUVWXYZ1234567890--<':/.ABCDEFHGHIJKLMNOPQRS"
30GOTO 160
40DEFFN' 15
50SELECT PRINT 215(132)
60PRINT "
.
70GOTO 60
80DEFFN'14
90SELECT PRINT 215(132)
100PRINT HEX(OE)
110PRINT "THIS IS A TEST OF THE WANG MODEL 2272 MATRIX PRINTER TEST TEST"
120PRINT "ABCDEFGHIJKLMNPOQRSTUVWXYZ 1234567890 !@#%&*()-+>:?..../;<=- abcdefghijklmnopqrstuvwxyz abcdefghijklmnopqrstuvwxyz 12345
67890"
130PRINT HEX(OE)
140PRINT "abcdefghijklmnopqrstuvwxyz 1234567890 !@#%&*()-+>:?..../;<=-+*/"
150GOTO 100
160 DEFFN'00
170SELECT PRINT 005
180PRINT "LIST AVAILABLE SPECIAL FUNCTIONS SFOO"
190PRINT "DIAGNOSTIC TEST FOR 65 LINES/PAGE FORM SFO1"
200PRINT "SPACES FOR ADJUSTMENTS SF15"
210PRINT "CHARACTER QUALITY TEST SF14"
220 STOP
230DEFFN'01
240SELECT PRINT 215(132)
250PRINT "1. THIS IS THE FIRST LINE OF THE PRINT OUT"
260PRINT :PRINT :PRINT :PRINT :PRINT "6. THIS IS THE SIXTH LINE"
270PRINT "7. VERTICAL TAB STARTS FROM THIS LINE"
280FOR I=1TO 8
290  (I+I)*6
300PRINT HEX(OB):PRINTUSING 305.N
305  ##, VERTICAL TAB. HEX(OB)
310NEXT I
320PRINT "55. THE NEXT TEST IS FOR THE LINE FEED CODE HEX(OA)"
330FOR I=1TO 3
340PRINT HEX(OA)
350NEXT I
360PRINT "59. THIS LINE SHOULD BE PRINTED BEFORE END OF DOCUMENT"
370PRINT "1.-----THIS SHOULD BE THE FIRST LINE AFTER END OF DOCUMENT.-----"
-----
380A#=HEX(4100004200004300004400004500004600)
390PRINT A#
400FOR I=1TO 10
410PRINT "ABCDEFGHIJKLMNPOQRSTUVWXYZ1234567890-#!@#%&*()-+'/:.?....abcdehijklmnopqrstuvwxyz!@#%&*()-+1234567890-#!?./<'ABCD EFGHIJK"
420PRINT HEX(OE):PRINT "TTTT===5555wwwiiiiiiiiMMMM::::::::::iiiiiiiiTTT=55wwwiiiiiiiiBBBBNN"
430NEXT I
440FOR I=1TO 254
450PRINT "AB":
460NEXT I
470PRINT HEX(OB):PRINT "37. VERTICAL TAB. HEX(OB)"
480FOR I=1TO 10
490PRINT HEX(OA)
500NEXT I
510PRINT "48. 10 LINE-FEEDS. HEX(OA)"
520PRINT "THIS LINE SHOULD NOT BE PRINTED. UNLESS THE PRINTER IS NOT RESPONDING TO THE DELETE CODE HEX(7F)":HEX(7F)
530PRINT "50. YUM! SHOULD HEAR THE BELL SOUND THREE TIMES"
540PRINT HEX(O7)
550FOR I=1TO 300

```

6-17

560 NEXT D
570PRINT HEX(07)
580 FOR D= 1TD 300
590 NEXT D
600PRINT HEX(07)
610PRINT "51. AFTER THIS LINE IS PRINTED THERE SHOULD BE A FORM-FEED"
620PRINT HEX(0C)
630PRINT "66. -----"
-----"

6.3 PREVENTIVE MAINTENANCE

6.3.1 VISUAL CHECKS (QUARTERLY)

1. Printer cooling fan and servo motor cooling fan. Check for obstructions.
2. Cleanliness of carriage guide bar and guide plate. If dirty, oil and wipe clean.
3. Check all drive belts for wear, tension and alignment.
4. Cleanliness of timing fence. Wipe with a soft clean cloth (use mild detergent only, if needed). AVOID USE OF ANY ORGANIC SOLVENTS.
5. Check ribbon tape for wear, quality of print and ribbon tension.
6. Check striker bar for cleanliness and surface condition.
7. Check paper guides for spring tension and alignment.
8. Check electrical ribbon conductor and wiring for possible abrasions from rotating units. Insure that wiring has not vibrated loose from retaining clips and troughs.
9. Examine carriage stops for loose pads or excessive wear.

6.3.2 ADJUSTMENTS

Any adjustments required are covered in detail in Section 5.

6.3.3 LUBRICATION (QUARTERLY)

Print Head lubrication is a requirement to reduce print wire breakage as explained in ISN #96, dated 12/16/75.

LUBRICATION PROCEDURE

NOTE:

Lubricant can be ordered using Wang Part #660-0180.

Remove the print head cover. Remove the sponge from the print wires and soak it with the lubricant. Press the sponge against the rear of the print bearing. This forces some of the lubricant into the bearing holes. Using a Q tip or lint free absorbent material, dab each entrance and exit hole of the guide tubes with the lubricant. Replace sponge and print head cover.

Immediately after lubricating, exercise the print head for several minutes insuring that each solenoid is used during printing. This allows the lubricant to make contact with all surfaces of the guide tubes and bearing.

6.4 TROUBLESHOOTING

6.4.1 TROUBLESHOOTING HINTS

TABLE 6-1

SYMPTOM	CAUSE	SOLUTION
1. Power turn on and no lights.	1A. Fuse blown. 1B. +5V low. 1C. No voltage. 1D. Q15 (heat sink) bad. No +5V to logic.	1A. Replace fuse. 1B. Check and adjust +5V. 1C. Replace 6728/7028. 1D. Replace Q15.
2. Power turn on and alarm light comes on.	2A. Servo circuit breaker switch set in Off position. 2B. Repeated setting On/Off of servo circuit breaker switch.	2A. Reset switch. 2B1. Adjust SW0 and SW1 as per Section 5.3.7 and 5.3.8. 2B2. +5V not high enough for servo circuit to work.
3. During power prime solenoids fire.	3A. Defective 6728/7028. 3B. Q1 on 6728/7028 not switching +9V.	3A. Replace 6728/7028. 3B. Replace Q1 on 6728/7028.
4. Power prime and carriage does not return to left margin.	4A. Check servo circuit breaker. 4B. Check for paper jam in paper guide preventing carriage from returning. 4C. Main drive belt and pulleys binding.	4A. Reset switch. 4B. Remove paper. Check paper guides for alignment and tension. 4C. Check adjustments as per Sections 5.3.3 and 5.3.4.
5. Power on; depress select button and select lamp does not come on.	5A. Defective lamp. 5B. Defective switch. 5C. Defective connection switch. 5D. Defective 6576/7076.	5A. Replace lamp. 5B. Replace switch. 5C. Continuity check. 5D. Replace 6576/7076.

NOTE:

Use the same procedure for checking Top of Form, clear and linefeed switches.

SYMPTOM	CAUSE	SOLUTION
6. <i>Front cover is open</i> ; CPU tells printer to print but no carriage movement.	6A. Cover open switch is on.	6A. Manually pull switch to closed position.
7. <i>Front cover is closed</i> ; CPU tells printer to print but no carriage movement.	7A. Cover open switch wired wrong. 7B. Cover open switch defective. 7C. Defective 6576/7076.	7A. Check wiring. 7B. Replace switch. 7C. Replace 6576/7076.
8. Ribbon is at the end, but does not change direction.	8A. Ribbon rivot on ribbon broken off. 8B. Ribbon direction switches not working. 8C. Ribbon direction circuit not working. 8D. Ribbon drive motor not working. 8E. Ribbon jumped ribbon guide arm.	8A. Replace ribbon. 8B. Replace switches 8C1. 6577 defective. 8D1. Check voltage to motor. 8D2. Replace ribbon drive motor. 8D3. Triac blown. 8E. Replace ribbon to proper position in guide arm.
9. Erratic forward motion of carriage during printing.	9A. Oversized countersink holes on tachometer mounting bracket. 9B. Loose tachometer belt. 9C. Defective tachometer. 9D. Defective servo. 9E. Defective servo circuit	9A. Shim mounting screws with #2 lock washers to lift screws away from tachometer. 9B. Adjust per Section 5.3.14. 9C. Replace tachometer 9D. Replace servo motor. 9E. Replace 6577.
10. Carriage assembly returning at slow speed after printing a line.	10A. SW1 reed switch appears defective. 10B. 6577 PCB defective.	10A. Replace reed switch or align magnet. 10B. Replace 6577.
11. Carriage return fast with no deceleration.	11A. Defective 6577. 11B. SW1 defective.	11A. Replace 6577. 11B. Replace SW1.
12. Intermittent loss of servo drive during printing.	12A. Bad connection. 12B. Heat sink.	12A. A check seating of all pins and connectors. 12B. Q17 or Q18 is intermittently shorting out.

SYMPTOM	CAUSE	SOLUTION
13. No power to servo drive mechanism, but power lights on.	13A. Servo circuit breaker off.	13A. Reset breaker.
	13B. Bad connection.	13B. Check seating of pins and connectors.
	13C. +5V logic not up.	13C. Adjust +5V logic.
14. Printing consecutive short lines of 1 to 10 characters per line and circuit breaker goes off.	14A. Defective timing on 6576.	14A. Fix cap.
15. No printing, but carriage movement.	15A. No video signal.	15A. Check photo coupler signal.
	15B. Defective timing fence.	15B. Replace timing fence.
	15C. Timing on 6728/7028.	15C. Adjust 50% duty cycle on 6728/7028 or replace 6728/7028.
	15D. No +9V.	15D. Replace 6728/7028.
16. No delays between manual linefeeds.	16A. 6576/7076 defective.	16A. Replace 6576/7076.
17. No linefeeds except under program control.	17A. Defective linefeed switch.	17A. Replace switch.
	17B. Defective 6576.	17B. Replace 6576/7076.
18. Continuous paper feed when top of form executed.	18A. Defective 6577.	18A. Replace 6577.
	18B. VFU defective.	18B1. Adjust VFU
		18B2. Replace paper tape.
		18B3. Replace LED.
		18B4. Replace photocell.
	18C. No VFU tape.	18C. Install tape.
19. Poor print quality at one specific location.	19A. Burr on chassis.	19A. Check carriage bearing guide shaft or plate for dirt or burrs at that location.
	19B. Defective timing fence.	19B. Replace timing fence.
20. Poor print quality everywhere (characters not symmetrical).	20A. Timing 6728.	20A. Adjust 50% duty cycle 6728.
	20B. Photocoupler.	20B. Replace photocoupler.
	20C. Head penetration.	20C. Adjust head penetration.
	20D. Solenoids in head maladjusted.	20D. Remove head assembly and adjust print head to specification.
	20E. Print head loose.	20E. Tighten head.

SYMPTOM	CAUSE	SOLUTION	
21. Missing dots in character	21A. Defective ROM on 6728.	21A. Replace ROM in 6728.	
	21B. Defective pwr. transistor on heat sink.	21B. Replace transistor on heat sink.	
	21C. Maladjusted solenoid.	21C. Adjust solenoid.	
	21D. Broken solenoid wire.	21D. Replace solenoid.	
22. Print head catching ribbon during printing.	22A. Head penetration exceeds .005".	22A. Adjust penetration.	
	22B. Ribbon worn out with too much head penetration.	22B. Replace ribbon-Adjust penetration.	
	22C. Solenoid staying in fixed position.	22C1. Replace solenoid.	22C1. Replace solenoid.
		22C2. Replace pwr. transistor on heat sink.	22C2. Replace pwr. transistor on heat sink.
22C3. Replace 6728.		22C3. Replace 6728.	
22D. Strobe too long.	22D. Adjust strobe length.		
23. Print quality light on one side.	23A. Striker bar maladjusted.	23A. Adjust striker bar.	
	23B. Ribbon height maladjusted.	23B. Adjust ribbon height.	
24. Paper streaked during print.	24A. Head penetration too close.	24A. Increase head to striker bar gap.	
	24B. Paper not within usable specs.	24B. Advise user to replace with paper meeting specifications.	
	24C. Print solenoid dragging on paper.	24C. Adjust solenoid.	
	24D. Ribbon guides maladjusted.	24D. Adjust ribbon guides.	
	24E. Ribbon drive assembly tilted causing ribbon to lean.	24E. Adjust ribbon drive assembly.	

6.4.2 MISCELLANEOUS TROUBLESHOOTING AIDS

A 6736 tester board is available to test WANG matrix printer Models 621W, 721W, 2221W and 1222 LPO. The 6736 tester can be used to isolate maintenance problems to the printer or the CPU. The 6736 board generates ASCII uppercase character codes which can be normal or expanded by setting a switch selector on the board. This tester facilitates the self check of a 72 Printer. To utilize the tester turn on power and push control select button.

For Models 2221W and 1222 LPO

The 6736 tester board has two connectors which will permit plugging it into the printer rear I/O amphenol connector or J12 on the top of the chassis by removing cable connector from J12.

For Models 621W, 721W

1. To utilize the 6736 tester board, remove INTERFACE CONTROL board 6751 from J12 and J13 after removing I/O cable connector from the connector on the 6751.
2. The cable connector can then be plugged into J12 if it is desired to use the 6736 tester in the rear I/O amphenol connector. If not, plug 6736 directly into J12.

SECTION

7

ELECTRI-

CAL

SCHE-

MATICS

THE SCHEMATICS, WHEN AVAILABLE, ARE ON THE LAST FICHE IN THIS SET.

SECTION

8

MECHANICAL

ASSEMBLY

DRAWINGS

SECTION 8
MECHANICAL ASSEMBLY DRAWINGS

8.1 INTRODUCTION

Section 8 includes the mechanical assembly drawings for the Model 72 printer as listed below.

Also included are exploded views and drawings of the main assembly and associated mechanical and electromechanical devices. Each exploded view of the assemblies has an attached parts listing which includes a description and Wang Part Number. An item number has been assigned to each piece to assist in the numerical sequence of disassembly (1, 2, 3 etc.) and reassembly (reverse sequence). Item numbers are also used to assist the user in identifying and ordering replacement parts.

NOTE:

Included in some of the parts listings, the reader is referred to WANG drawing numbers that are not included in this manual.

8.2 ASSEMBLY DRAWINGS

(a) PRINTER:

<u>DESCRIPTION</u>	<u>DRAWING NUMBER</u>
CHASSIS ASSY.	6635-53 (2 sheets)
HEAT SINK ASSY.	6635-54
RESISTOR, BRKT. ASSY.	6635-55

(b) STAND ASSY: (OPTIONAL)

MATRIX PRINTER STAND (TOP LOAD)	6641
MATRIX PRINTER STAND (FRONT LOAD)	6641-200 (LATER MODEL)

(c) MAIN ASSY. AND ASSOCIATED MECHANICAL & ELECTROMECHANICAL DEVICES
(EXPLODED VIEWS AND DRAWINGS)

<u>FIGURE NO.</u>	<u>DESCRIPTION</u>	<u>PARTS/INDEX # LISTS</u>
FIG. 8-1	MODEL 72 MAIN ASSEMBLY (4 SHTS)	PARTS LIST #8-1
FIG. 8-2	PAPER FEED, FORMAT, FRAME ASSY. (3 SHTS)	PARTS LIST #8-2
FIG. 8-3	VERTICAL FORMAT CONTROL ASSY. (1 SHT)	PARTS LIST #8-3
FIG. 8-4	VERNIER CLUTCH ASSY. (2 SHTS)	PARTS LIST #8-4
FIG. 8-5	COVERS, L.H. & R.H. PAPER GUIDE ASSYS.	PARTS LIST #8-5
FIG. 8-6	R.H. RIBBON FEED ASSY.	PARTS LIST #8-6
FIG. 8-7	L.H. RIBBON FEED ASSY.	PARTS LIST #8-7
FIG. 8-8	CARRIAGE ASSY.	PARTS LIST #8-8
FIG. 8-9	CARRIAGE DRIVE & TACHOMETER ASSY.	PARTS LIST #8-9
FIG. 8-10	PRINT HEAD ASSY.	PARTS LIST #8-10
FIG. 8-11	FENCE, MOD-72 ASSY.	PARTS LIST #8-11
FIG. 8-12	CARRIAGE DR. SHAFT & BRG. HOUSING ASSY.	PARTS LIST #8-12
FIG. 8-13	IDLER PULLEY & BRKT. ASSY.	PARTS LIST #8-13

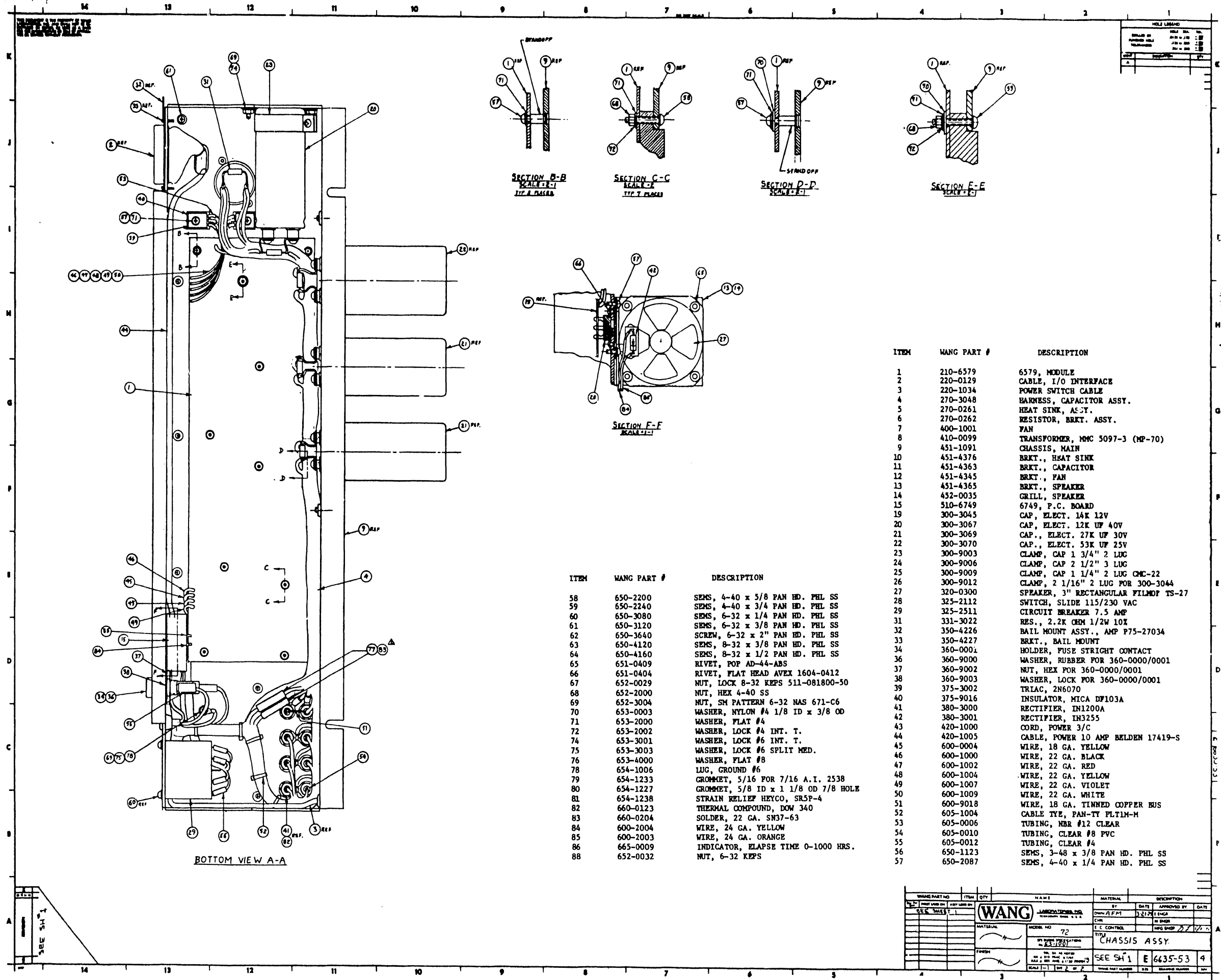

HOLD LEGEND			
DRWING NO.	REV.	DATE	BY
6635-53	1	3/27/64	W.A.P.
NUMBER OF SHEETS	TOTAL SHEETS	DATE	BY
1	1		

ITEM	WANG PART #	DESCRIPTION
58	650-2200	SEMS, 4-40 x 5/8 PAN HD. PHL SS
59	650-2240	SEMS, 4-40 x 3/4 PAN HD. PHL SS
60	650-3080	SEMS, 6-32 x 1/4 PAN HD. PHL SS
61	650-3120	SEMS, 6-32 x 3/8 PAN HD. PHL SS
62	650-3640	SCREW, 6-32 x 2" PAN HD. PHL SS
63	650-4120	SEMS, 8-32 x 3/8 PAN HD. PHL SS
64	650-4160	SEMS, 8-32 x 1/2 PAN HD. PHL SS
65	651-0409	RIVET, POP AD-44-ABS
66	651-0404	RIVET, FLAT HEAD AVEX 1604-0412
67	652-0029	NUT, LOCK 8-32 KEPS 511-081800-50
68	652-2000	NUT, HEX 4-40 SS
69	652-3004	NUT, SM PATTERN 6-32 NAS 671-C6
70	653-0003	WASHER, NYLON #4 1/8 ID x 3/8 OD
71	653-2000	WASHER, FLAT #4
72	653-2002	WASHER, LOCK #4 INT. T.
74	653-3001	WASHER, LOCK #6 INT. T.
75	653-3003	WASHER, LOCK #6 SPLIT MED.
76	653-4000	WASHER, FLAT #8
78	654-1006	LUG, GROUND #6
79	654-1233	GROMMET, 5/16 FOR 7/16 A.I. 2538
80	654-1227	GROMMET, 5/8 ID x 1 1/8 OD 7/8 HOLE
81	654-1238	STRAIN RELIEF HEYCO, SR5P-4
82	660-0123	THERMAL COMPOUND, DOW 340
83	660-0204	SOLDER, 22 GA. SN37-63
84	600-2004	WIRE, 24 GA. YELLOW
85	600-2003	WIRE, 24 GA. ORANGE
86	665-0009	INDICATOR, ELAPSE TIME 0-1000 HRS.
88	652-0032	NUT, 6-32 KEPS

ITEM	WANG PART #	DESCRIPTION
1	210-6579	6579, MODULE
2	220-0129	CABLE, I/O INTERFACE
3	220-1034	POWER SWITCH CABLE
4	270-3048	WIRNESS, CAPACITOR ASSY.
5	270-0261	HEAT SINK, AC.T.
6	270-0262	RESISTOR, BRKT. ASSY.
7	400-1001	FAN
8	410-0099	TRANSFORMER, MMC 5097-3 (MP-70)
9	451-1091	CHASSIS, MAIN
10	451-4376	BRKT., HEAT SINK
11	451-4363	BRKT., CAPACITOR
12	451-4345	BRKT., FAN
13	451-4365	BRKT., SPEAKER
14	452-0035	GRILL, SPEAKER
15	510-6749	6749, P.C. BOARD
19	300-3045	CAP, ELECT. 12K 12V
20	300-3067	CAP, ELECT. 12K UF 40V
21	300-3069	CAP., ELECT. 27K UF 30V
22	300-3070	CAP., ELECT. 53K UF 25V
23	300-9003	CLAMP, CAP 1 3/4" 2 LUG
24	300-9006	CLAMP, CAP 2 1/2" 3 LUG
25	300-9009	CLAMP, CAP 1 1/4" 2 LUG CMC-22
26	300-9012	CLAMP, 2 1/16" 2 LUG FOR 300-3044
27	320-0300	SPEAKER, 3" RECTANGULAR FILMOP TS-27
28	325-2112	SWITCH, SLIDE 115/230 VAC
29	325-2511	CIRCUIT BREAKER 7.5 AMP
31	331-3022	RES., 2.2K OHM 1/2W 10%
32	350-4226	RAIL MOUNT ASSY., AMP P75-27034
33	350-4227	BRKT., RAIL MOUNT
34	360-0001	HOLDER, FUSE STRIGHT CONTACT
36	360-9000	WASHER, RUBBER FOR 360-0000/0001
37	360-9002	NUT, HEX FOR 360-0000/0001
38	360-9003	WASHER, LOCK FOR 360-0000/0001
39	375-3002	TRIAC, 2N6070
40	375-9016	INSULATOR, MICA DF103A
41	380-3000	RECTIFIER, IN1200A
42	380-3001	RECTIFIER, IN3255
43	420-1000	CORD, POWER 3/C
44	420-1005	CABLE, POWER 10 AMP BELDEN 17419-S
45	600-0004	WIRE, 18 GA. YELLOW
46	600-1000	WIRE, 22 GA. BLACK
47	600-1002	WIRE, 22 GA. RED
48	600-1004	WIRE, 22 GA. YELLOW
49	600-1007	WIRE, 22 GA. VIOLET
50	600-1009	WIRE, 22 GA. WHITE
51	600-9018	WIRE, 18 GA. TINNED COPPER BUS
52	605-1004	CABLE TIE, PAN-TY PLTIM-M
53	605-0006	TUBING, NBR #12 CLEAR
54	605-0010	TUBING, CLEAR #8 PVC
55	605-0012	TUBING, CLEAR #4
56	650-1123	SEMS, 3-48 x 3/8 PAN HD. PHL SS
57	650-2087	SEMS, 4-40 x 1/4 PAN HD. PHL SS

WANG PART #	ITEM	QTY	MATERIAL	DESCRIPTION
72	1		WANG	CHASSIS ASSY.
SEE SH 1				
DATE: 3/27/64				
BY: W.A.P.				
CHECKED: J.M.S.				
APPROVED: J.M.S.				
TITLE: CHASSIS ASSY.				
SCALE: 1" = 1"				
SHEET: 1 OF 1				
DRAWING NO.: 6635-53				
REV: 1				

11 10 9 8 7 6 5 4 3 2 1

THIS DOCUMENT IS THE PROPERTY OF WANG LABORATORIES, INC. AND SHALL NOT BE REPRODUCED OR COPIED OR USED AS A BASIS FOR THE MANUFACTURE OR SALE OF APPARATUS OR SERVICES WITHOUT PERMISSION.

NOTES:
1. APPLY THERMAL COMPOUND ITEM 23 TO BOTH SIDES OF MICA WASHERS ITEMS 19 & 20 AT ASSY.

HOLE LEGEND		
HOLE DIA	TOL	LOC
DRILLED OR PUNCHED HOLES	0.005	0.005
TOLERANCES	0.005	0.005
	0.005	0.005
	0.005	0.005

QTY	DESCRIPTION	QTY

ITEM	WANG PART #	DESCRIPTION
1	270-3050	HEAT SINK
2	375-1012	TRANSISTOR, 40250
3	375-1019	TRANSISTOR, 2N6246
4	375-1043	TRANSISTOR, MJ3000 (TO-3)
5	375-1044	TRANSISTOR, MJ2500 (TO-3)
6	375-1045	TRANSISTOR, 2N6261 (TO-66)
7	375-1046	TRANSISTOR, 2N6282 TO-3
8	375-1047	TRANSISTOR, 2N6285 TO-3
9	375-9014	INSULATOR, TRANSISTOR MTC WICKERSSER TH-1 (LARGE)
10	375-9013	INSULATOR, TRANSISTOR MTC WICKERSSER TH-2 (SMALL)
11	478-0287	HEAT SINK
12	600-0000	WIRE, 18 GA. BLACK
13	600-9018	WIRE, 18 GA. TINNED COPPER BUS
14	605-0002	TUBING, CLEAR #15
15	605-0010	TUBING, CLEAR #8 PVC
16	650-3131	SCREW, 6-32 x 3/8 NYLON COVERED FIL HD SLOT
17	650-3140	SEW, 6-32 x 1/2 PAN HD, PRL SS
18	652-3004	NUT, SH PATTERN 6-32 HAS 671-C4
19	653-0006	WASHER, MICA (LARGE) FOR POWER TRANSISTOR
20	653-0015	WASHER, MICA (SMALL) FOR POWER TRANSISTOR
21	653-3000	WASHER, FLAT #6
22	654-1004	LDC, GRIND #6
23	660-0123	THERMAL COMPOUND, DOW 340

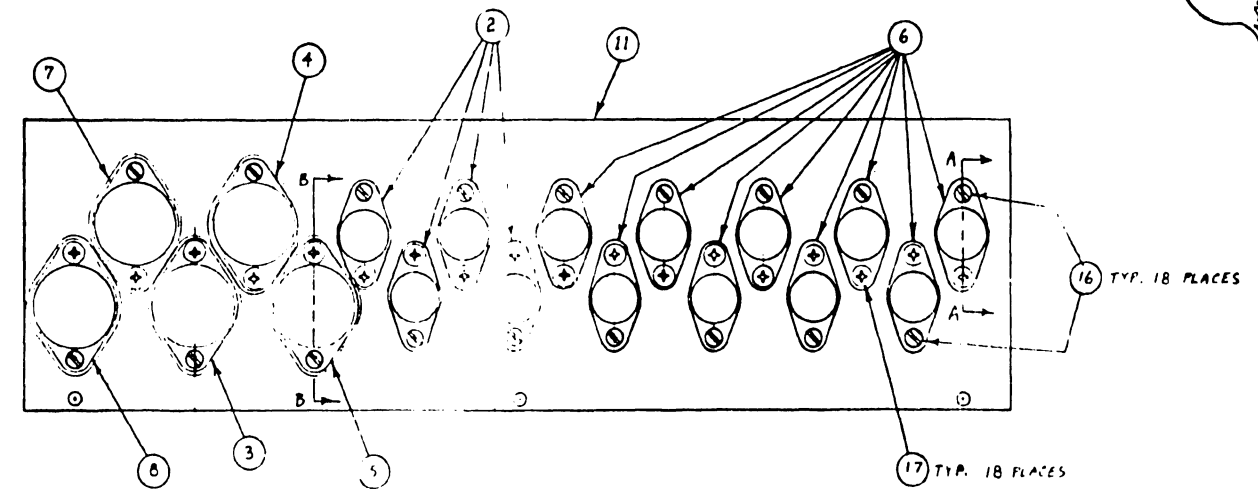
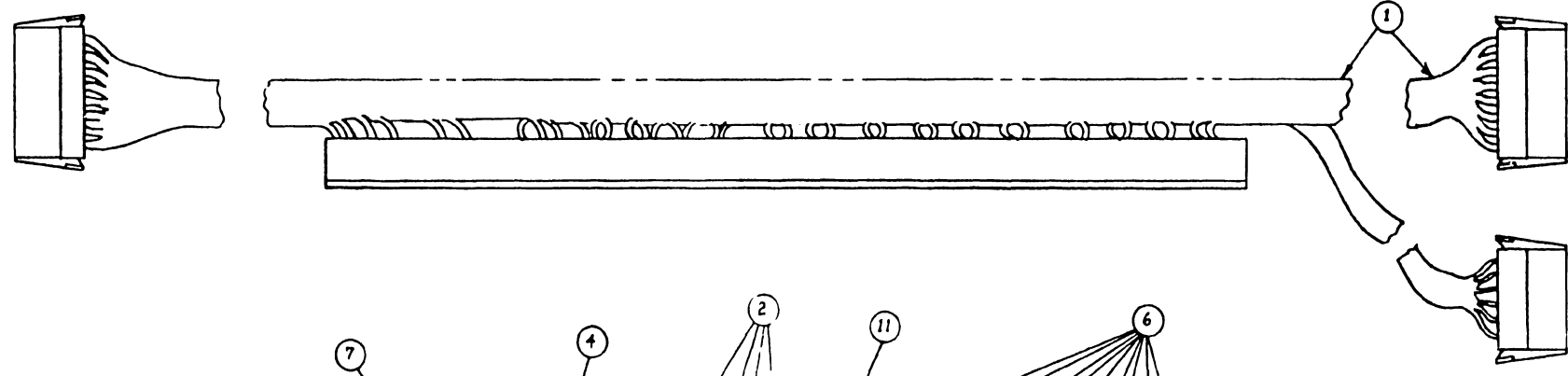
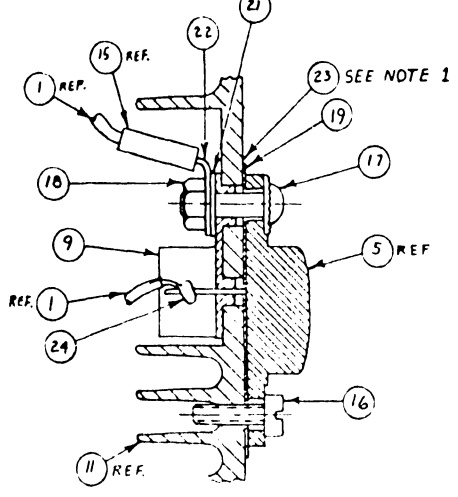
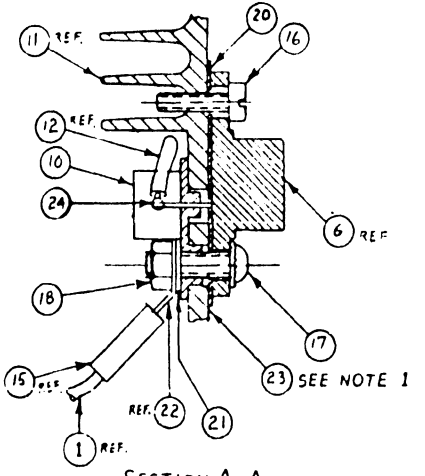
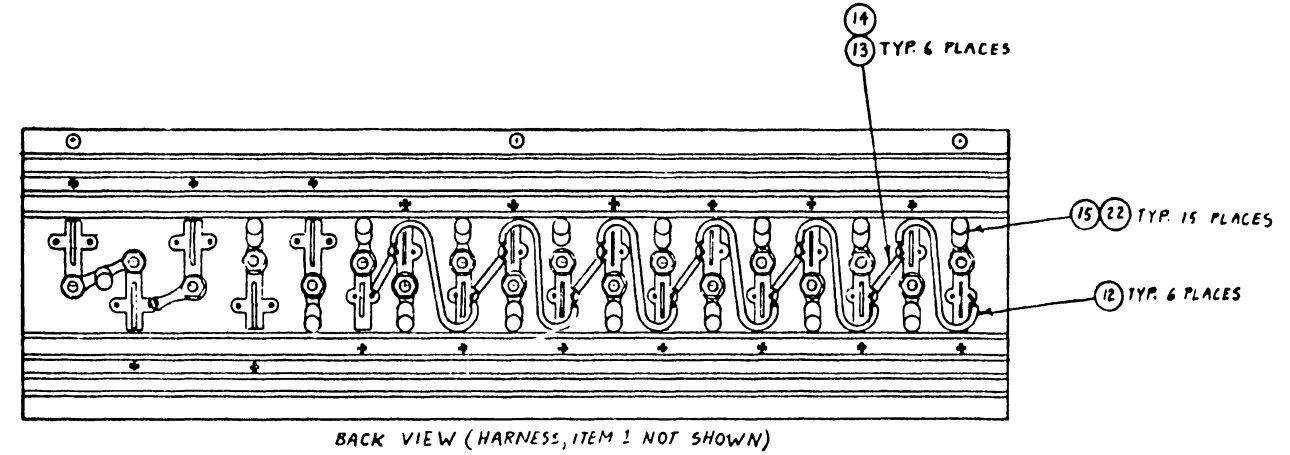

FOR INTERCONNECTION SEE DWG E6635-999

REV.	DESCRIPTION	DATE
1	REVISED	1/19/54

WANG PART NO.	ITEM	QTY	NAME	MATERIAL	DESCRIPTION
1	HEAT SINK	1	WANG	600-0000	HEAT SINK ASSY.

BY	DATE	APPROVED BY	DATE
DWN AFM	1/19/54	E ENGR	
CHP		M ENGR	
E C CONTROL		MFG ENGR	

TOL. EQ. AS NOTED	REF. & DIM. FRAC. 2:1 & 4:1	MAX. & MIN. DIM. 2:1 & 4:1	FINISH	SCALE	SHEET	OF	WANG PART NUMBER	REV.
				1:1	1	1	6635-54	0

7

6

5

4

DO NOT SCALE

3

2

1

THIS DRAWING AND INFORMATION
HEREIN, IS THE PROPERTY OF WANG
LABORATORIES, INC. IT IS TO BE
REPRODUCED ONLY BY THE
WHOLE OR IN PART BY THE
THE MANUFACTURE OF THIS IS
WITHOUT WRITTEN PERMISSION.

HOLE LEGEND		
DRILLED OR PUNCHED HOLE	HOLE DIA.	TOL.
DRILLED OR PUNCHED HOLE	0.125 to .125	±.001
TOLERANCES:	124 to .250	±.001
	.251 to .500	±.002
IDENT.	DESCRIPTION	QTY.
A		

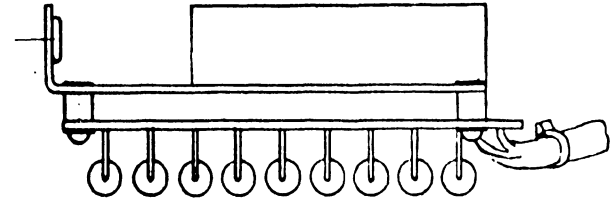

ITEM	WANG PART #	DESCRIPTION
1	210-6568	6568, MODULE
2	270-3052	RESISTOR, HARNESS
3	451-4358	BRKT., RESISTOR & SUPPORT
4	650-2087	SEMS, #4-40 x 1/4 PAN HD. PHL SS
5	653-2000	WASHER, FLAT #4
6	462-0169	STAND OFF, PEM BSOS-440-10
7	652-0008	NUT, 6-32 PEM CL632-2

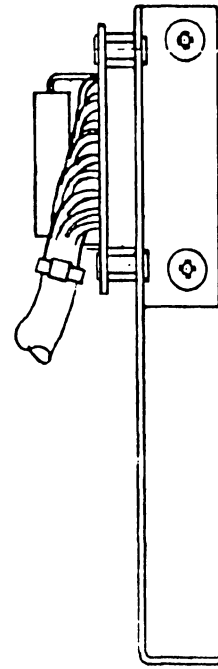
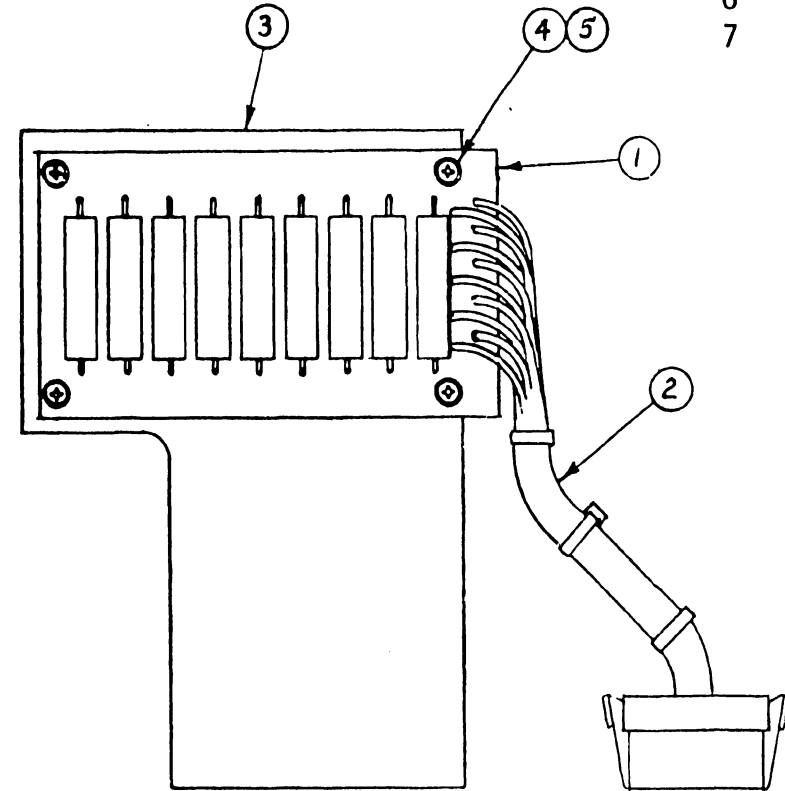

SEE PL 6635-55

REV	DATE	DESCRIPTION	WANG PART NO	ITEM	QTY	NAME	MATERIAL	DESCRIPTION		
			QTY	FIRST USED ON	ASSY USED ON	BY	DATE	APPROVED BY	DATE	
1		TOTAL								
1		E6635-53								
							MODEL NO -72		TITLE RESISTOR, BRKT ASSY	
FINISH 							TOL EX AS NOTED XX = 010 FRAC ± 1/64 XXX = 005 ANG ± 1°30' FINISH V		270-0242 C 6635-55 0	
SCALE 1-1 SHT 1 OF 1							WANG PART NUMBER 55-9E99 C		SIZE C	
							DRAWING NUMBER 6635-55		REV 0	

THIS DRAWING IS THE PROPERTY OF THE
 COMPANY AND IS NOT TO BE REPRODUCED
 OR COPIED IN ANY MANNER WITHOUT
 THE WRITTEN PERMISSION OF THE
 COMPANY.

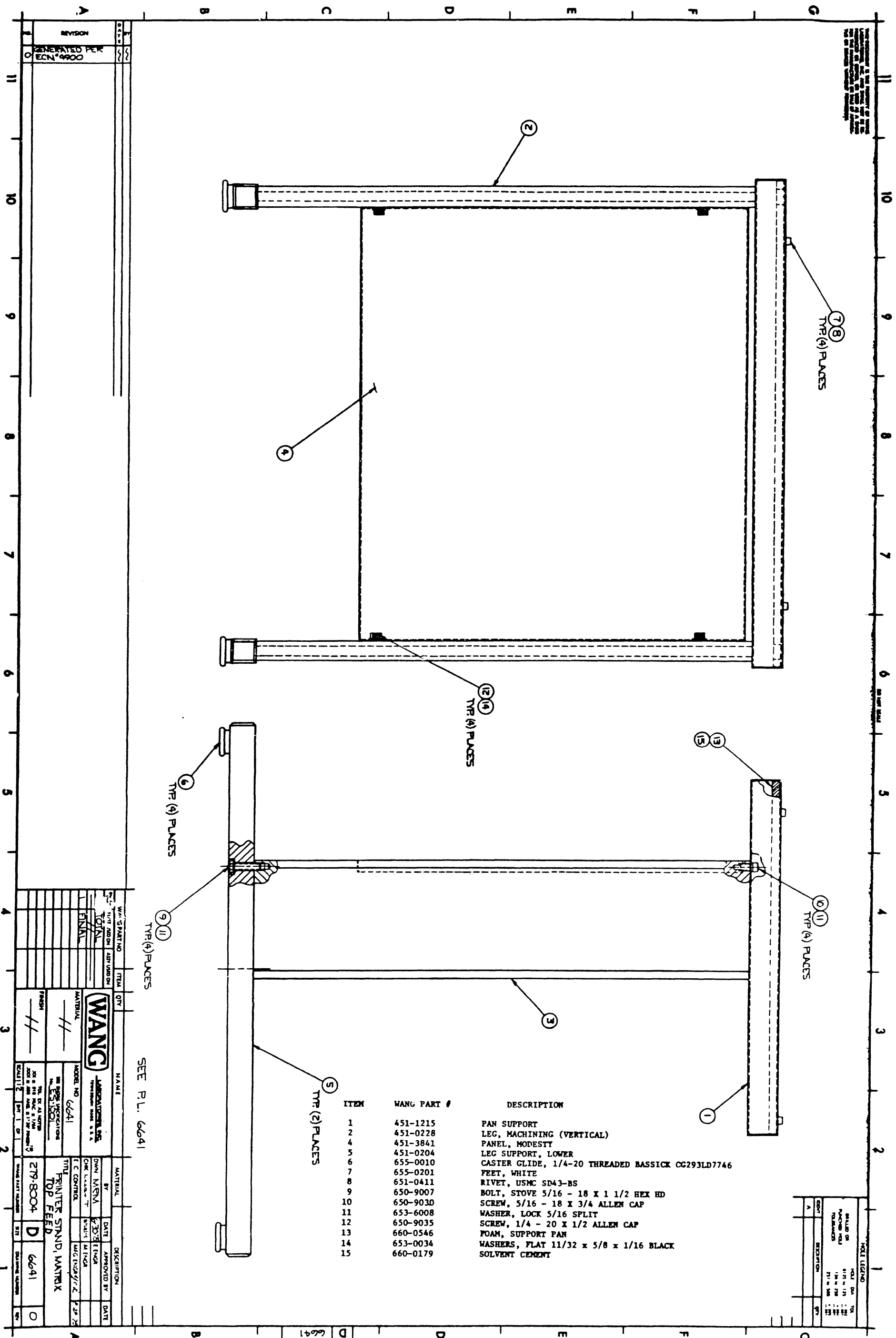

ITEM	WANG PART #	DESCRIPTION
1	451-1215	PAN SUPPORT
2	451-0228	LEG, MACHINING (VERTICAL)
4	451-3841	PANEL, MODESTY
5	451-0204	LEG SUPPORT, LOWER
6	655-0010	CASTER GLIDE, 1/4-20 THREADED BASSICK CG293LD7746
7	655-0201	FEET, WHITE
8	651-0411	RIVET, USMC SD43-BS
9	650-9007	BOLT, STOVE 5/16 - 18 X 1 1/2 HEX HD
10	650-9030	SCREW, 5/16 - 18 X 3/4 ALLEN CAP
11	653-6008	WASHER, LOCK 5/16 SPLIT
12	650-9035	SCREW, 1/4 - 20 X 1/2 ALLEN CAP
13	660-0546	FOAM, SUPPORT PAN
14	653-0034	WASHERS, FLAT 11/32 x 5/8 x 1/16 BLACK
15	660-0179	SOLVENT CEMENT

MATERIAL		DESCRIPTION	
DATE	APPROVED BY	DATE	APPROVED BY
279-8004	D	6641	O

DATE	DESCRIPTION	BY	APPROVED BY
279-8004	PRINTER STAND, MATRIX TOP FEED	D	6641

THE INFORMATION CONTAINED ON THIS DRAWING IS THE PROPERTY OF WANG LABORATORIES, INC. AND IS CONFIDENTIAL AND PROPRIETARY TO WANG LABORATORIES, INC. IT SHALL NOT BE COPIED, REPRODUCED OR USED IN WHOLE OR IN PART FOR ANY PURPOSE.

ALL DIMENSIONS IN PARENTHESES INDICATE TOLERANCES TO BE MAINTAINED TO EACH DIMENSION.

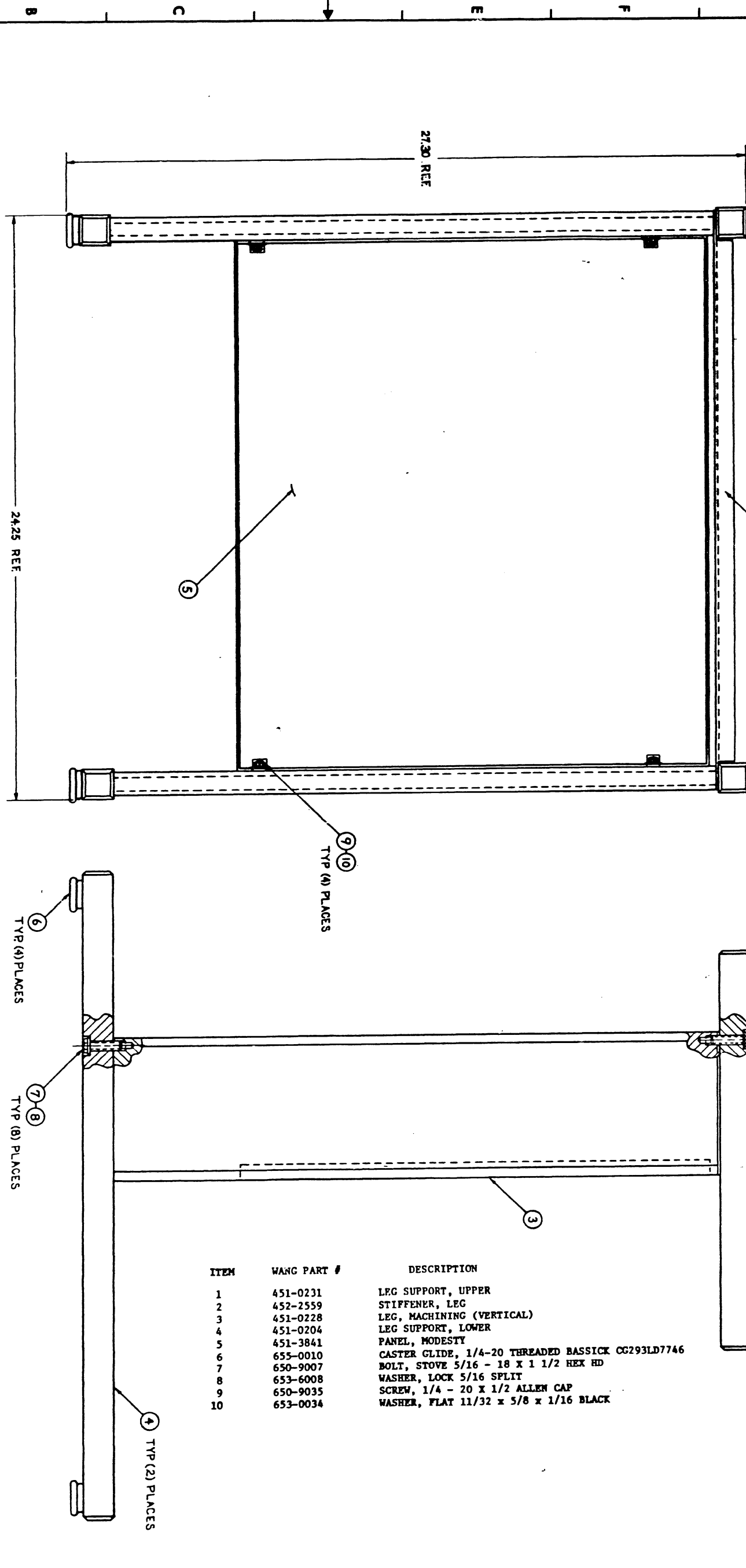

ITEM	WANG PART #	DESCRIPTION
1	451-0231	LEG SUPPORT, UPPER
2	452-2559	STIFFENER, LEG
3	451-0228	LEG, MACHINING (VERTICAL)
4	451-0204	LEG SUPPORT, LOWER
5	451-3841	PANEL, MODESTY
6	655-0010	CASTER GLIDE, 1/4-20 THREADED BASSICK CG293LD7746
7	650-9007	BOLT, STOVE 5/16 - 18 X 1 1/2 HEX HD
8	653-6008	WASHER, LOCK 5/16 SPLIT
9	650-9035	SCREW, 1/4 - 20 X 1/2 ALLEN CAP
10	653-0034	WASHER, FLAT 11/32 x 5/8 x 1/16 BLACK

SEE P.L. 6641-200

REVISION		DATE		BY	
WANG PART NO. 6641-200		DRAWING NO. 2-276		DATE 11-1-66	
MATERIAL		BY JBL		APPROVED BY	
BOOK NO. 6641		CHK		DATE	
SIT ENGINE (INSTRUCTIONS)		MFG ENGR		DATE	
M. E. C. 1001		MFG ENGR		DATE	
FINISH		TITLE PRINTER STAND, MATRIX		DATE	
		(FRONT LOADING)		DATE	
SCALE: 1" = 1'-0"		D 6641-200		O	

NO. 111	NO. 112	NO. 113	NO. 114	NO. 115

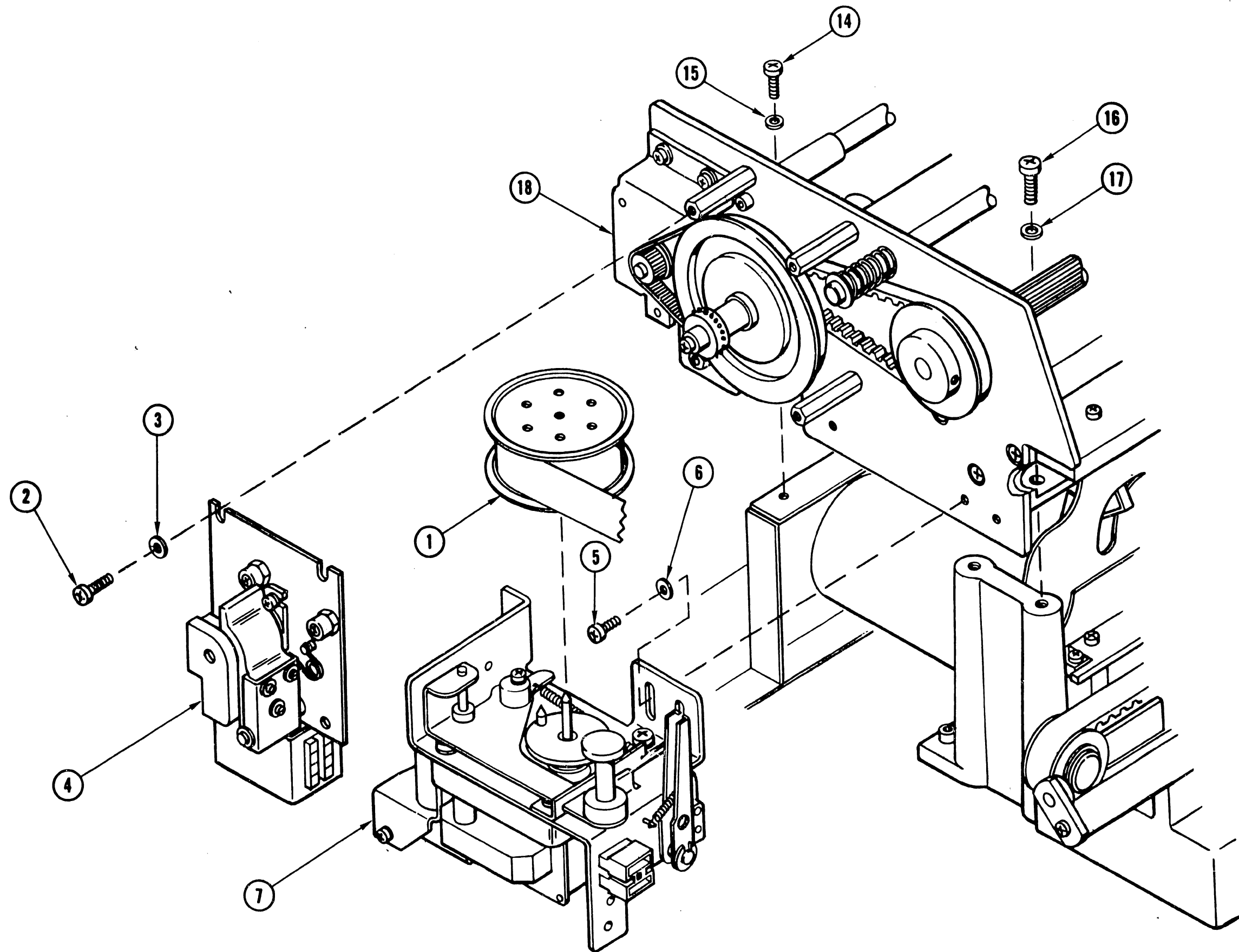

FIGURE 8-1 MATRIX PRINTER MECHANICAL ASSEMBLY SHEET 1 OF 4

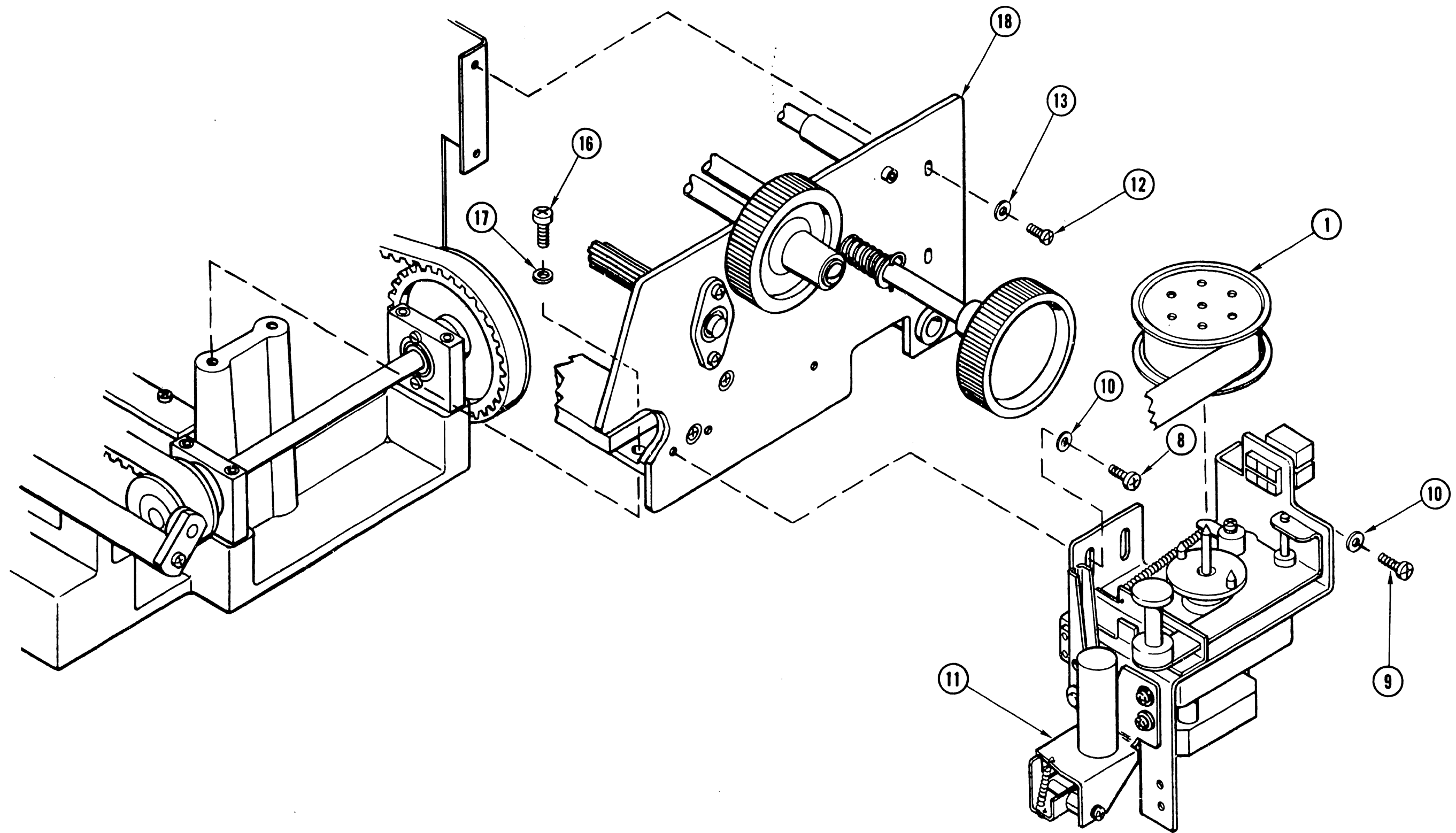

FIGURE 8-1 MATRIX PRINTER MECHANICAL ASSEMBLY SHEET 2 OF 4

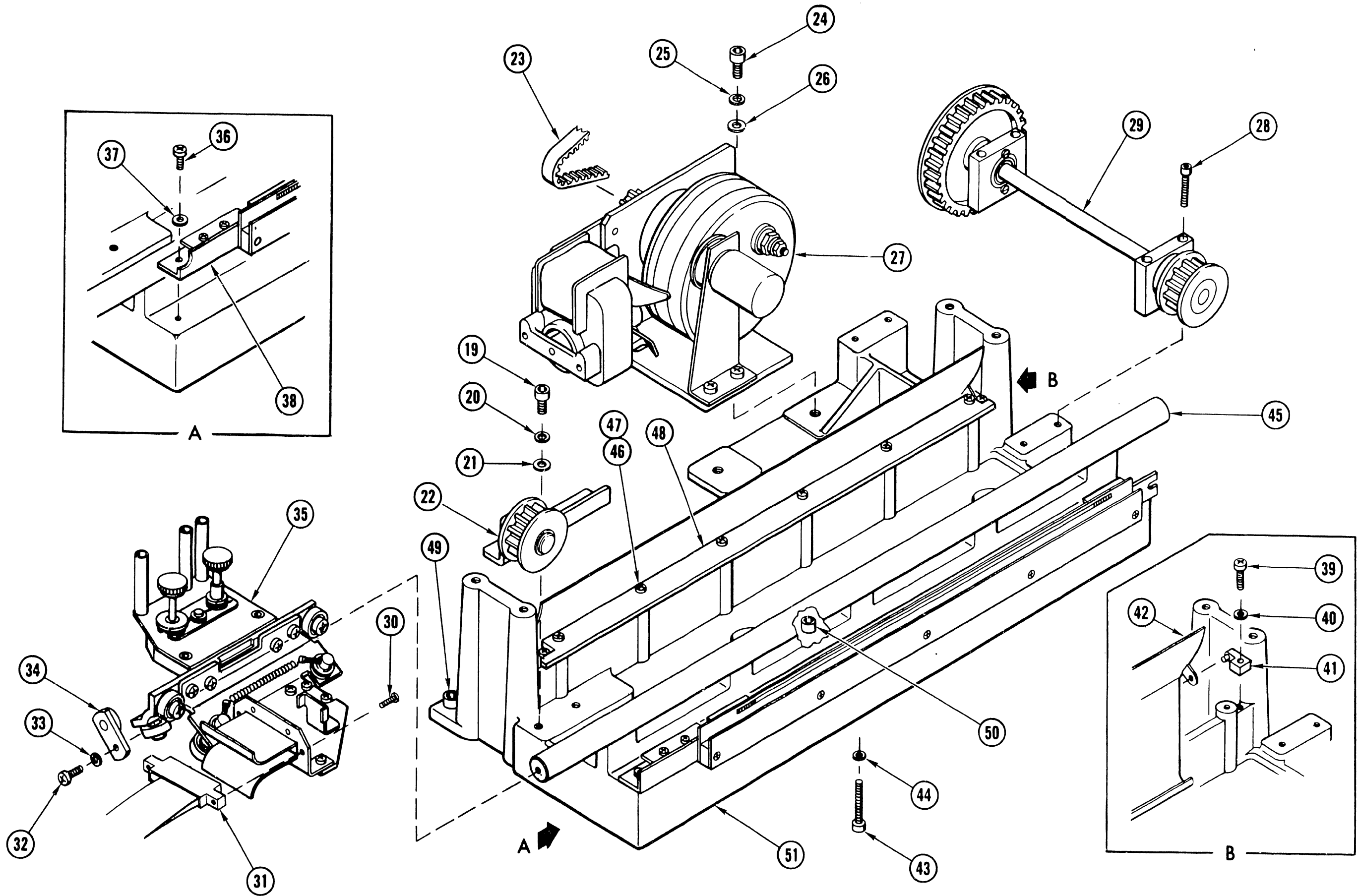

FIGURE 8-1 MATRIX PRINTER MECHANICAL ASSEMBLY SHEET 3 OF 4

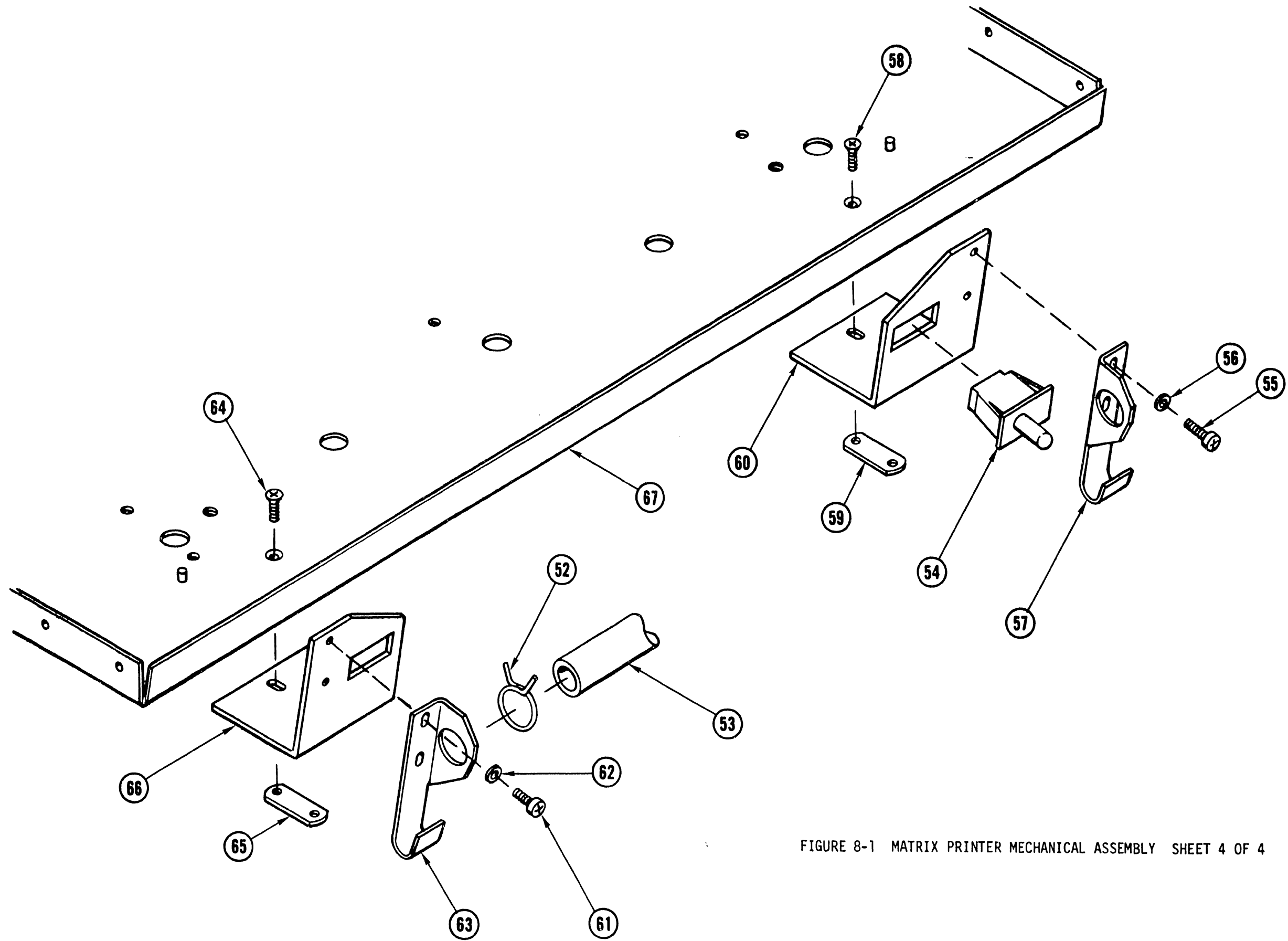

FIGURE 8-1 MATRIX PRINTER MECHANICAL ASSEMBLY SHEET 4 OF 4

PARTS LIST FOR FIGURE 8-1

ITEM NO.	PART NO.	DESCRIPTION	QTY. PER ASSEMBLY
-	279-5070-11 (6635-11)	MATRIX PRINTER MECHANICAL ASSEMBLY	REF
- 1	725-0159 (6615-231)	DOUBLE SPOOL TAPE	1
- 2	650-4120	SEMS, #8-32 x 3/8 PAN HD PHL SS	4
- 3	653-4000	WASHER, FLAT #8	4
- 4	279-5070-29 (6635-29)	FORMAT CONTROL ASSEMBLY	1
- 5	650-4120	SEMS, #8-32 x 3/8 PAN HD PHL SS	3
- 6	653-4000	WASHER, FLAT #8	3
- 7	279-5070-23 (6635-23)	RIBBON FEED, L.H. ASSEMBLY	1
- 8	650-4080	SEMS, #8-32 x 1/4 PAN HD PHL SS	2
- 9	650-4120	SEMS, #8-32 x 3/8 PAN HD PHL SS	1
-10	653-4000	WASHER, FLAT #8	3
-11	279-5070-24 (6635-24)	RIBBON FEED, R.H. ASSEMBLY	1
-12	650-4120	SCREW,	2
-13	653-4000	WASHER,	2
-14	650-3120	SCREW,	2
-15	653-3000	WASHER,	2
-16	650-6240	SCREW, #10-32 x 3/4 PAN HD PHL SS	4
-17	653-6001	WASHER, LOCK #10 INT. T	4
-18	279-5070-34 (6635-34)	PAPER FEED, FORMAT, FRAME ASSEMBLY	1
-19	650-9037	SCREW, #1/4-28 x 3/4 SOC. HD CAP	2
-20	653-6009	WASHER, LOCK 1/4 INT. T	2
-21	653-6000	WASHER, FLAT 1/4	2

ITEM NO.	PART NO.	DESCRIPTION	QTY. PER ASSEMBLY
-22		IDLER PULLEY & BRACKET ASSEMBLY	1
-23	656-0219	BELT, TIMING 140 x L037	1
-24	650-9044	SCREW, #1/4-28 x 5/8 SOC. HD CAP	2
-25	653-6009	WASHER, LOCK #1/4 INT. T	2
-26	653-6006	WASHER, FLAT #1/4	2
-27	279-5070-17 (6635-17)	CARRIAGE DRIVE MOTOR & TACHOMETER MOTOR ASSEMBLY	1
-28	650-6561	SCREW, #10-32 x 1-3/4 SOC. HD CAP	4
-29	279-5070-45 (6635-45)	CARRIAGE DRIVE SHAFT & BEARING HOUSING ASSEMBLY	1
-30	650-2120	SEMS, #4-40 x 3/8 PAN HD PHL SS	2
-31	420-1016 (6482-72)	HEAD CABLE PC ASSEMBLY	1
-32	650-4125	SCREW, #8-32 x 3/8 SOC. HD CAP BLK OX	2
-33	653-4001	WASHER, LOCK #8 INT. T	2
-34	451-4332 (6615-180)	BRACKET, BUMPER	2
-35	279-5070-19 (6635-19)	CARRIAGE ASSEMBLY	1
-36	650-4120	SCREW, #8-32 x 3/8 PAN HD PHL SS	5
-37	653-4000	WASHER, FLAT #8	5
-38	279-5070-46 (6635-46)	FENCE, MOD. 72 ASSEMBLY	1
-39	650-3166	SCREW	2
-40	653-3000	WASHER	2
-41	461-3249 (6615-203)	PIVOT, OUTER PAPER GUIDE	2
-42	452-4038 (6615-201)	PAPER GUIDE, OUTER	1
-43	650-4400	SCREW, #8-32 x 1-1/4 SOC. HD CAP	5

ITEM NO.	PART NO.	DESCRIPTION	QTY. PER ASSEMBLY
-44	653-4001	WASHER, LOCK #8 INT. T	5
-45	461-3176 (6615-39)	SHAFT, CARRIAGE GUIDE	1
-46	650-4200	SCREW, #8-32 x 5/8 PAN HD PHL SS	6
-47	653-4001	WASHER, LOCK #8 INT. T	6
-48	452-4016 (6615-30)	CARRIAGE GUIDE	1
-49	650-9035	SCREW, #1/4-20 x 1/2 SOC. HD CAP	3
-50	650-9040	SCREW, #1/4-20 x 1-3/8 SOC. HD CAP	3
-51	(6615-251)	BASE, CASTING	1
-52	654-1287	CLAMP, WIRE 11/16 AUVECO 5356	2
-53	461-3225 (6634-118)	TUBE SLIDE, FRONT	1
-54	325-0027	SWITCH, CHEAT INTERLOCK CH E69-30A	1
-55	650-4120	SEMS, #8-32 x 3/8 PAN HD PHL SS	2
-56	653-4000	WASHER, FLAT #8	2
-57	451-4355 (6634-104)	BRACKET, SLIDE TUBE, R.H.	1
-58	650-6161	SCREW, #10-32 x 1/2 FLAT HD PHL SS	2
-59	461-0058	NUT PLATE, OHIO TP 1716 ZINC PL	1
-60	458-0316 (6634-105)	MOUNT, SLIDE TUBE, R.H.	1
-61	650-4120	SEMS, #8-32 x 3/8 PAN HD PHL SS	2
-62	653-4000	WASHER, FLAT #8	2
-63	451-4354 (6634-104)	BRACKET, SLIDE TUBE, L.H.	1
-64	650-6161	SCREW, #10-32 x 1/2 FLAT HD PHL SS	2
-65	461-0058	NUT PLATE, OHIO TP 1716 ZINC PL	1
-66	452-0315	MOUNT, SLIDE TUBE, L.H.	1
-67	279-1011 (6634-12)	BOTTOM PAN ASSEMBLY	1

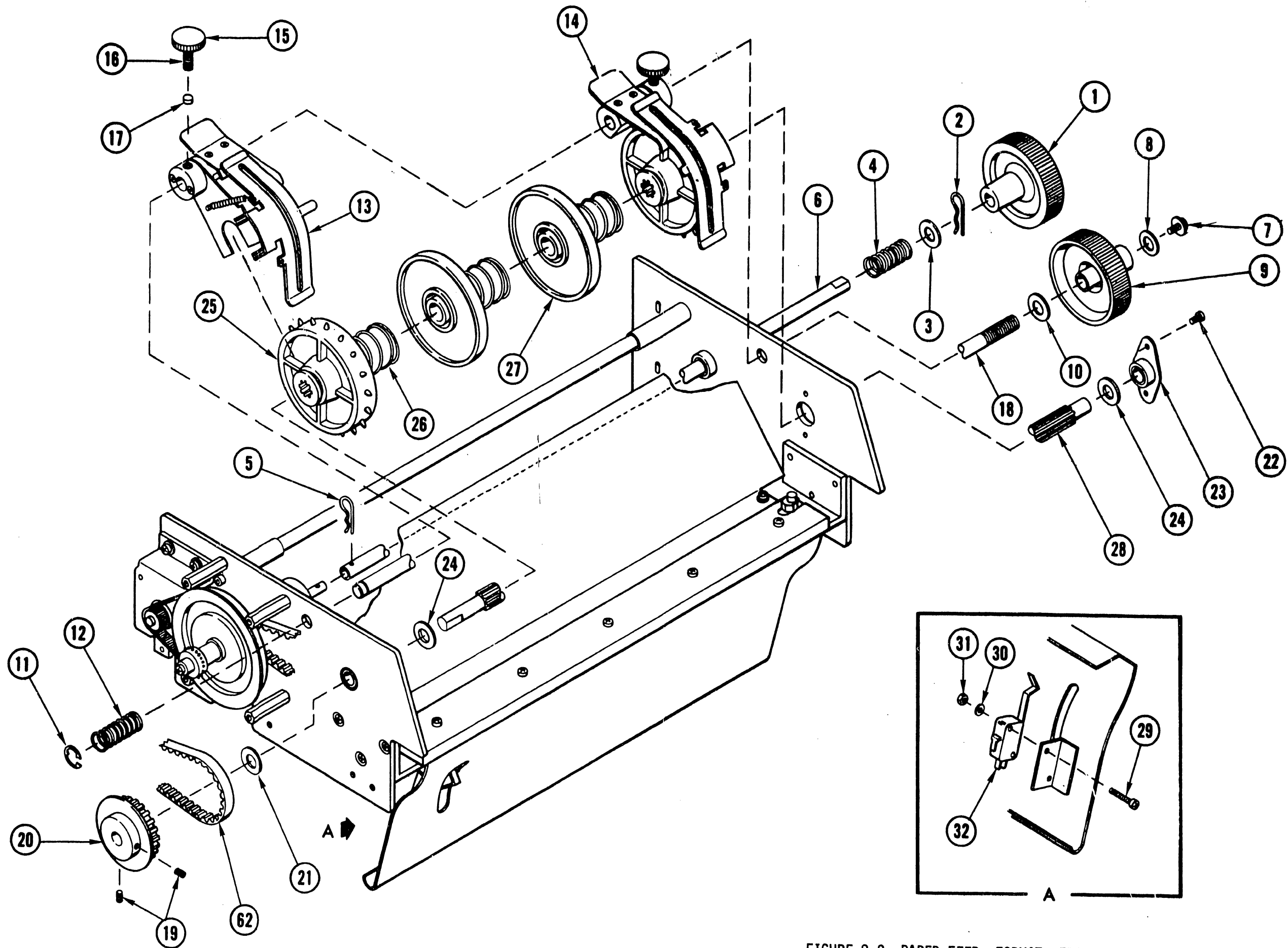

FIGURE 8-2 PAPER FEED, FORMAT, FRAME ASSEMBLY SHEET 1 OF 3

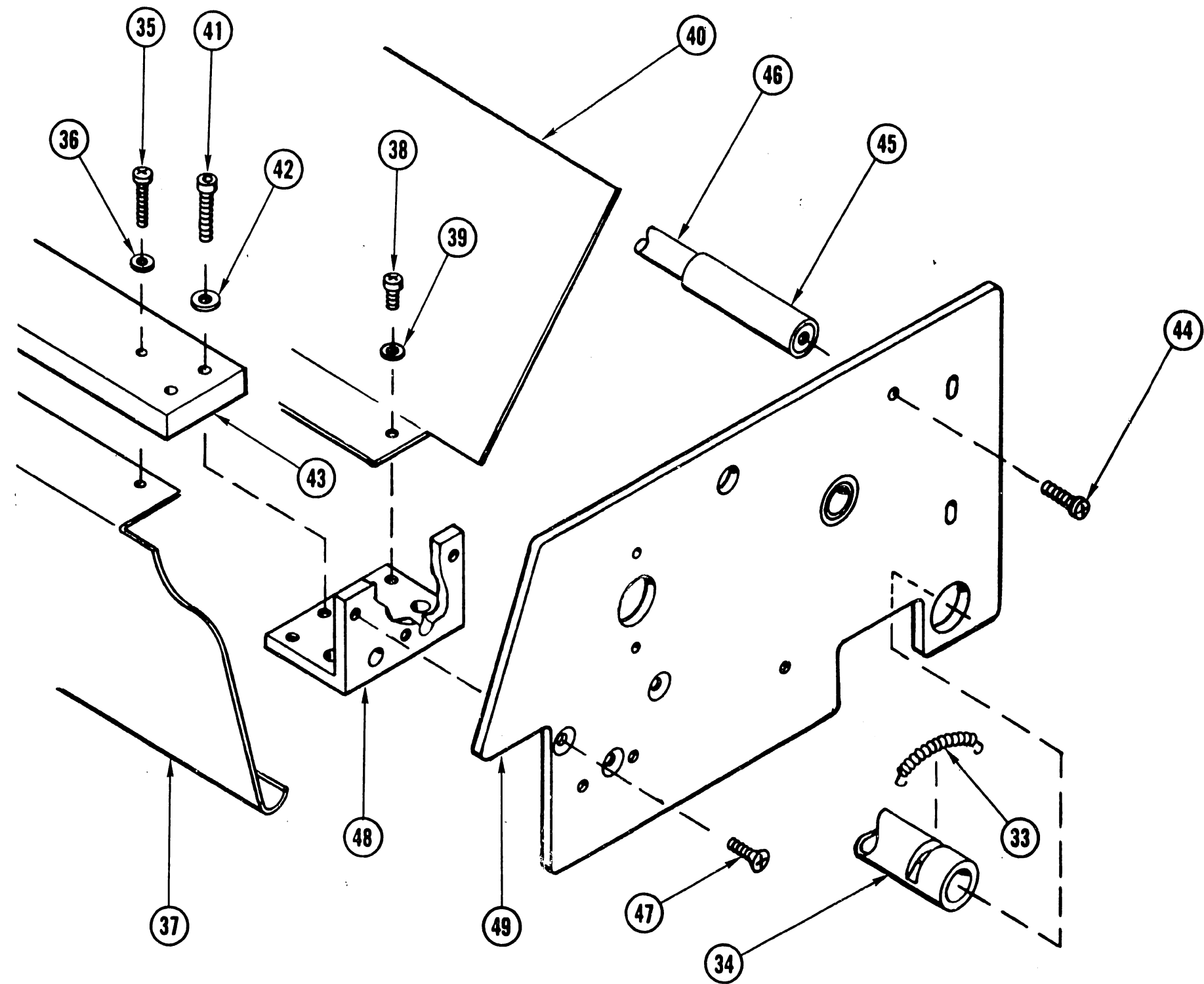

FIGURE 8-2 PAPER FEED, FORMAT, FRAME ASSEMBLY SHEET 2 OF 3

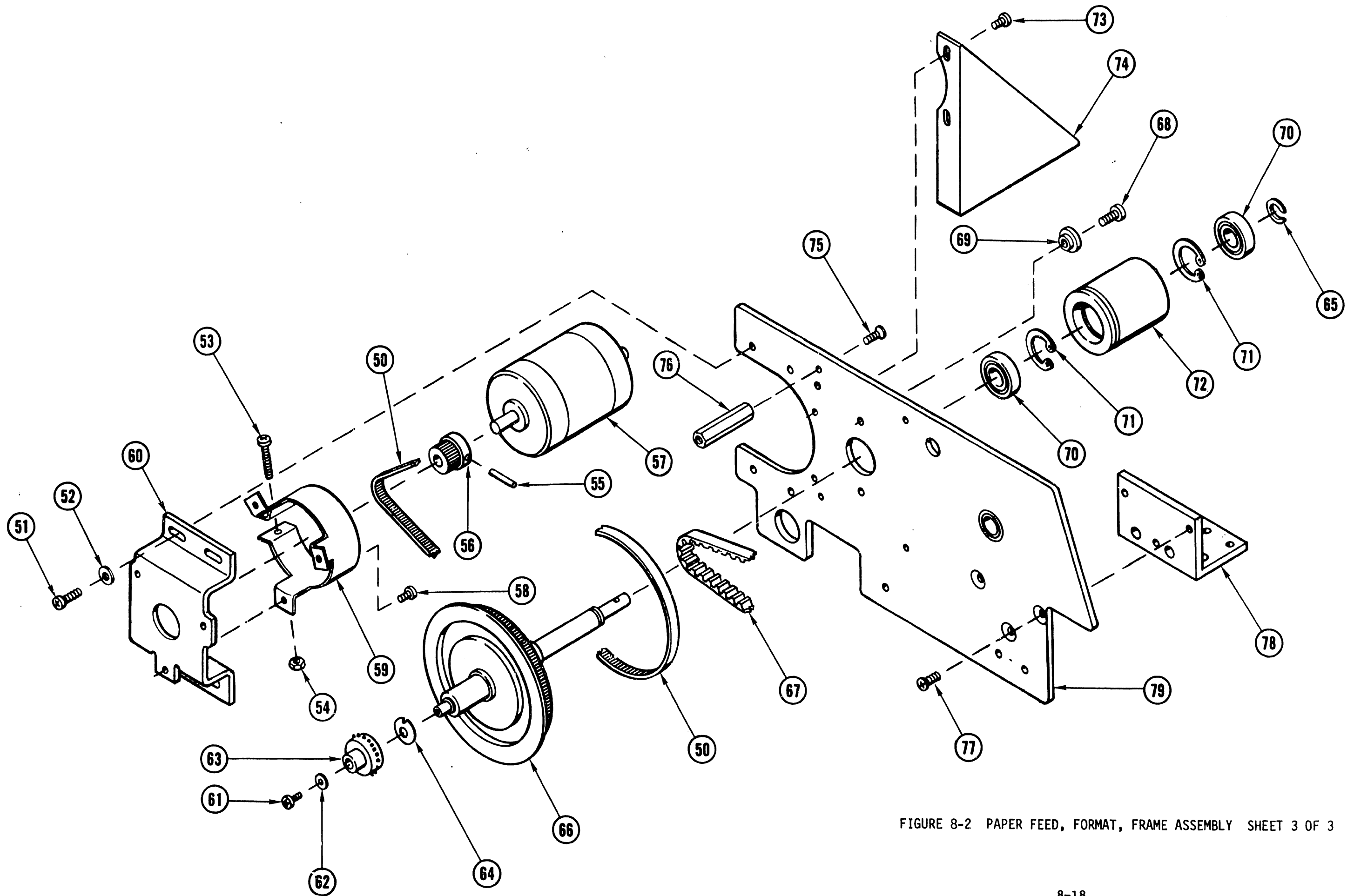

FIGURE 8-2 PAPER FEED, FORMAT, FRAME ASSEMBLY SHEET 3 OF 3

PARTS LIST FOR FIGURE 8-2

ITEM NO.	PART NO.	DESCRIPTION	QTY. PER ASSEMBLY
-	279-5070-34 (6635-34)	PAPER FEED, FORMAT, FRAME ASSEMBLY	REF
- 1	449-0109 (5300-1093)	KNOB, MOLDED "D" VERT. VERNIER	1
- 2	651-1531	HITCH PIN	1
- 3	653-0031	WASHER, NYLON 3/8 ID x 3/4 OD x 1/32 THK	1
- 4	465-1617	SPRING, VERNIER SHAFT LEE LC-038G-8	1
- 5	651-1531	HITCH PIN	1
- 6	461-3188 (6615-129)	SHAFT, VERNIER KNOB	1
- 7	650-4160	SEMS #8-32 x 1/2 PAN HD PHL SS	1
- 8	653-6018	WASHER, 3/16 ID x 3/4 OD x 1/16 THK STEEL	1
- 9	449-0108 (5300-1092)	KNOB, MOLDED "C" HORIZ. VERNIER	1
-10	653-0031	WASHER, NYLON 3/8 ID x 3/4 OD x 1/32 THK	1
-11	651-1704	SNAP RING, 5133-37	1
-12	465-1617	SPRING, VERNIER SHAFT LEE LC-038G-8	1
-13	279-5070-38 (6635-38)	COVER, L.H. PAPER GUIDE ASSEMBLY	1
-14	279-5070-39 (6635-39)	COVER, R.H. PAPER GUIDE ASSEMBLY	1
-15	655-0164	CAP, THUMB SCREW SIBER 83-98-904	2
-16	650-9037	SCREW, 1/4-28 x 3/4 SOC HD CAP	2
-17	458-0297 (6615-144)	PAD, LOCKING	2
-18	461-3170 (6615-48)	SHAFT, MARGIN ALIGNMENT	1
-19	650-6060	SCREW, #10-32 x 3/8 ALLEN HD CUP POINT	2

ITEM NO.	PART NO.	DESCRIPTION	QTY. PER ASSEMBLY
-20	478-0286 (6615-187)	PULLEY, (30 x L025 SPROCKET SHAFT DRIVE	1
-21	653-0031	WASHER, NYLON 3/8 ID x 3/4 OD x 1/32 THK	1
-22	650-4080	SEMS, #8-32 x 1/4 PAN HD PHL SS	2
-23	279-5070-59 (6635-59)	BEARING ASSEMBLY, SPLINE SHAFT	1
-24	651-1741	WASHER, THRUST, TRUARC 5900-39	2
-25	279-5070-63 (6635-63)	MOLDED SPROCKET & RUBBER ASSEMBLY	2
-26	465-1605 (6615-80)	SPRING, DISC SEPARATOR	3
-27	461-1029 (6615-158)	DISC, PAPER SUPPORT	2
-28	461-3175 (6615-89)	SHAFT, SPLINE	1
-29	650-2200	SEMS, #4-40 x 5/8 PAN HD PHL SS	2
-30	653-2000	WASHER, FLAT #4	2
-31	652-2000	NUT, HEX #4	2
-32	325-2403 M (6615-186)	MICROSWITCH, PAPER OUT (MOD)	1
-33	465-1622 M	SPRING, EXT. 3/16 x 1-3/8	2
-34	461-3218 (6634-109)	TUBE, SLIDE, REAR	1
-35	650-3200	SCREW, #6-32 x 5/8 PAN HD PHL SS	5
-36	653-3001	WASHER, LOCK #6 INT. T.	5
-37	452-4037 (6615-200)	PAPER GUIDE, INNER	1
-38	650-3100	SCREW, #6-32 x 5/16 PAN HD PHL SS	2
-39	653-3001	WASHER, LOCK #6 INT. T.	2
-40	451-2133 (6615-199)	COVER, LOWER REAR	1

ITEM NO.	PART NO.	DESCRIPTION	QTY. PER ASSEMBLY
-41	650-6246	SCREW, #10-32 x 3/4 SOC. HD CAP	4
-42	653-6000	WASHER, FLAT #10	4
-43	452-0023 (6615-45)	PLATE, STRICKER	1
-44	650-4120	SEMS, #8-32 x 3/8 PAN HD PHL SS	2
-45	465-0725 (6634-128)	BUSHING, SHOCK COVER	2
-46	461-3197 (6615-163)	ROD, TIE	1
-47	650-6127	SCREW, #10-32 x 3/8 FLAT HD PHL SS	3
-48	451-4303 (6615-34)	SIDE FRAME ANGLE	1
-49	279-5070-36 (6635-36)	FRAME, R.H. SIDE SUB-ASSEMBLY	1
-50	656-0216	BELT TIMING 139 T 40 PP 1/4 W BOG 139M	1
-51	650-4120	SEMS, #8-32 x 3/8 PAN HD PHL SS	4
-52	653-4000	WASHER, FLAT #8	4
-53	650-3240	SCREW, #6-32 x 3/4 PAN HD SS	1
-54	652-0032	KEPS NUT, #6-32	1
-55	651-1506	ROLL PIN, 1/16 x 1/2	1
-56	478-0270 (6615-157)	PULLEY, 15 TOOTH 40 DP	1
-57	400-0031 (6615-249)	MOTOR, STEPPER	1
-58	650-4080	SEMS, #8-32 x 1/4 PAN HD PHL SS	3
-59	300-9004	CAP CLAMP, 1-3/4 DIA 3 LUG	1
-60	451-4393 (6615-246)	BRACKET, PAPER FEED MOTOR	1
-61	650-2097	SCREW, #4-40X 1/4 HEX HD LONG LOCK	1
-62	653-2000	WASHER, FLAT #4	1

ITEM NO.	PART NO.	DESCRIPTION	QTY. PER ASSEMBLY
-63	461-2015 M (6615-122)	SPROCKET, 24 TOOTH 10 PITCH	1
-64	465-1606 (6615-130)	SPRING, SPROCKET ADJ.	1
-65	651-1729	SNAP RING 5103-37	1
-66	279-5070-32 (6635-32)	VERNIER CLUTCH ASSEMBLY	1
-67	656-0221	BELT, TIMING 120X L025	1
-68	650-4120	SEMS, #8-32 x 3/8 PAN HD PHL SS	2
-69	452-2548 (6615-125)	CLAMP, BEARING HOUSING	2
-70	465-0011	BEARING, BALL SR6/PPD	2
-71	651-1739	RETAINING RING, TRUARC N5000-87	2
-72	461-3185 (6615-126)	HOUSING, BEARING	1
-73	650-4080	SEMS, #8-32 x 1/4 PAN HD PHL SS	2
-74	451-4359 (6615-191)	SUPPORT BRACKET, L.H.	1
-75	650-4161	SCREW, #8-32 x 1/2 FLAT HD PHL SS	4
-76	462-0228	SPACER, FORMAT CONTROL	4
-77	650-6127	SCREW, #10-32 x 3/8 FLAT HD PHL SS	2
-78	451-4303 (6615-34)	SIDE FRAME ANGLE	1
-79	279-5070-35 (6635-35)	FRAME, L.H. SIDE SUB-ASSEMBLY	1

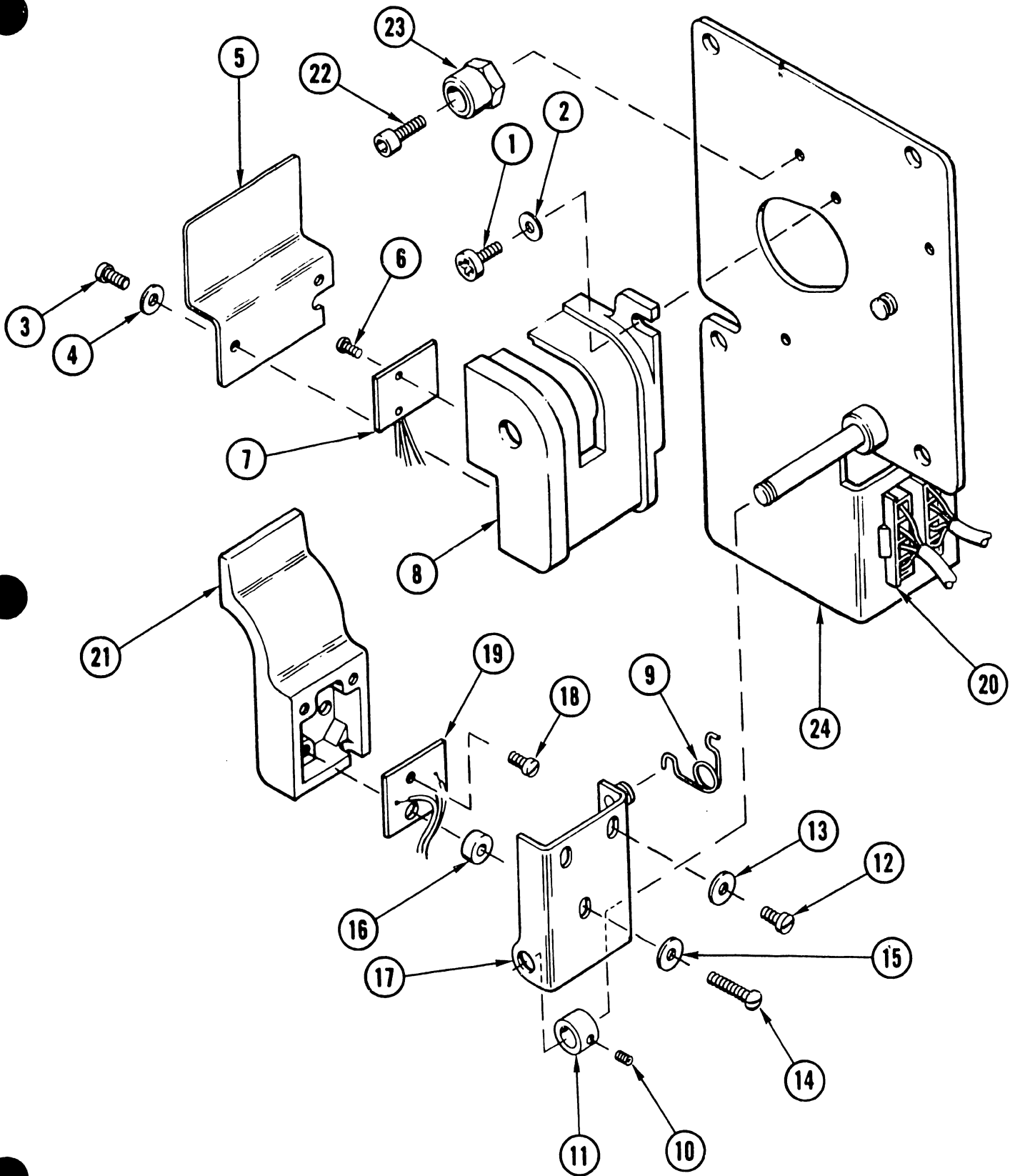

FIGURE 8-3 VERTICAL FORMAT CONTROL ASSEMBLY

PARTS LIST FOR FIGURE 8-3

ITEM NO.	PART NO.	DESCRIPTION	QTY. PER ASSEMBLY
-	279-5070-29 (6635-29)	VERTICAL FORMAT CONTROL ASSEMBLY	REF
- 1	650-3085	SCREW, #6-32 x 1/4 PAN HD BLK OX	2
- 2	653-3000	WASHER, FLAT #6	2
- 3	651-0015	SCREW, #4 x 1/4 TYPE 25 SELF TAP PAN HD PHL	2
- 4	653-2000	WASHER, FLAT #4	2
- 5	452-2140 (6615-134)	COVER, CELL MOUNT	1
- 6	651-0014	SCREW, #2 x 1/4 TYPE 25 SELF TAP PHL HD	2
- 7	210-6574	6574, P.C. BOARD PHOTOTRANSISTOR	1
- 8	461-3186 (6615-115)	HOUSING, PHOTOTRANSISTOR	1
- 9	465-0938 (5776-429)	SPRING, TORSION B5776-429	1
-10	650-2040	SCREW, 4-40 x 1/8 SOC SET	1
-11	465-0409	COLLAR	1
-12	651-0015	SCREW, #4 x 1/4 TYPE 25 SELF TAP PAN HD PHL	2
-13	653-2000	WASHER, FLAT #4	2
-14	651-0016	SCREW, #4 x 1/2 TYPE 25 SELF TAP PAN HD PHL	1
-15	653-2000	WASHER, FLAT #4	1
-16	462-0229 (6615-136)	SPACER, L.E.D. COVER	1
-17	279-5070-31 (6635-31)	COVER, L.E.D. ASSEMBLY	1
-18	651-0015	SCREW, #4 x 1/4 TYPE 25 SELF TAP PAN HD PHL	1

ITEM NO.	PART NO.	DESCRIPTION	QTY. PER ASSEMBLY
-19	210-6575	6575, P.C. BOARD L.E.D.	1
-20	270-3053 (6482-45)	FORMAT CONTROL HARNESS	1
-21	461-3191 (6615-116)	HOUSING, LIGHT EMITTING DIODE	1
-22	650-3134	SCREW, #6-32 x 3/8 SOC HD CAP	2
-23	458-0295 (6615-138)	STOP, FORMAT CONTROL	2
-24	279-5070-30 (6635-30)	MOUNTING PLATE, FORMAT CONTROL ASSEMBLY	1

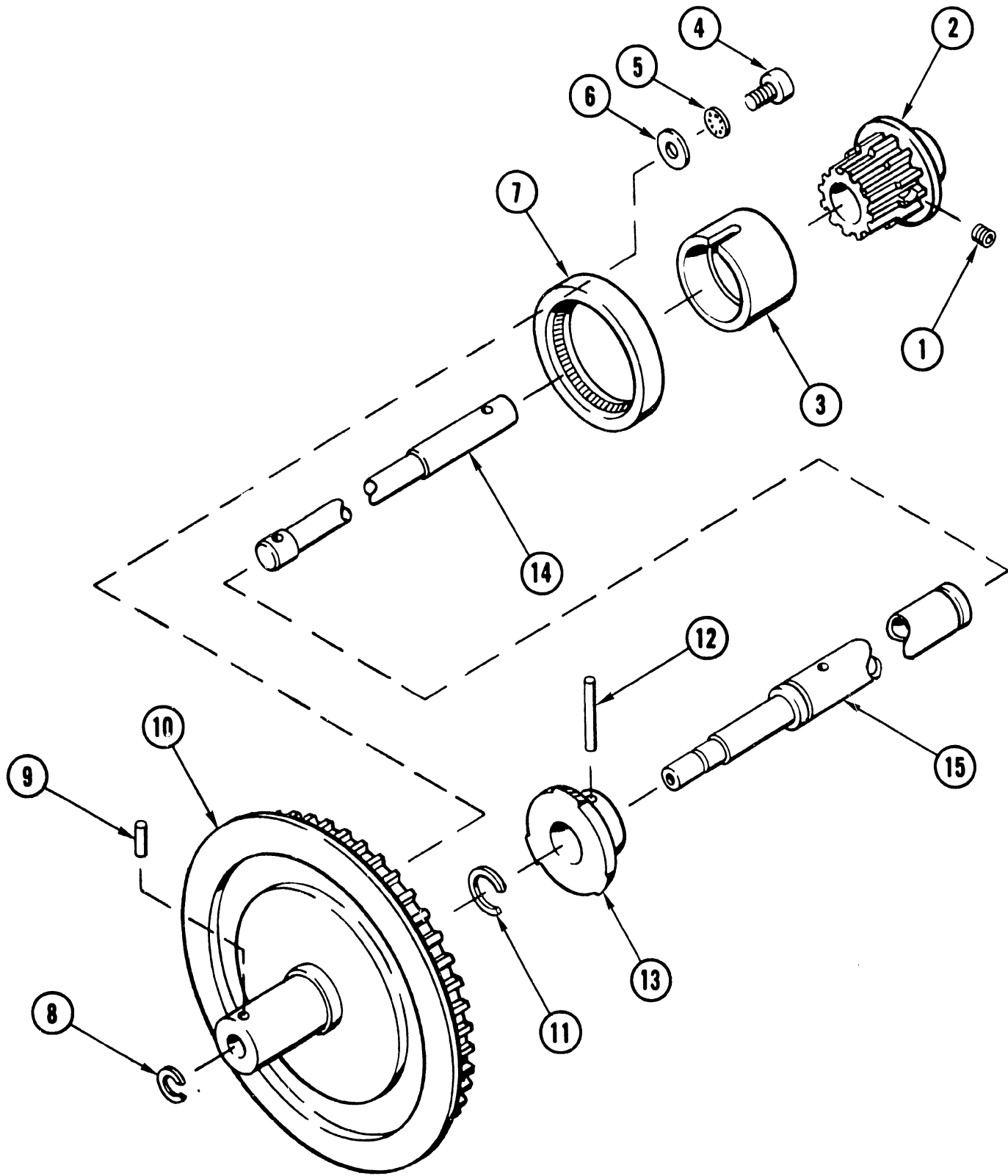

FIGURE 8-4 VERNIER CLUTCH ASSEMBLY

PARTS LIST FOR FIGURE 8-4

ITEM NO.	PART NO.	DESCRIPTION	QTY. PER ASSEMBLY
-	279-5070-32 (6635-32)	VERNIER CLUTCH ASSEMBLY	REF
- 1	650-4048	SCREW 8-32 x 1/8 SOC HD	1
- 2	478-0268 (6615-123)	PULLEY, IDLER SHAFT, WITH FLANGE	1
- 3	465-0414 (6615-121)	COLLAR, IDLER SHAFT PULLEY	1
- 4	650-3134	SCREW, #6-32 x 3/8 SOC HD CAP SS	3
- 5	653-3001	WASHER, LOCK #6 INT TOOTH	3
- 6	653-3000	WASHER, FLAT #6	3
- 7	461-1030 (6615-164)	RING, VERNIER	1
- 8	651-1729	SNAP RING, CRESC TRUARC 5103-37	1
- 9	651-1640	PIN, DOWEL .062 x .25 SS	1
-10	478-0264 (6615-99)	PULLEY, IDLER	1
-11	651-1713	SNAP RING, CRESC TRUARC 5103-18	1
-12	651-1600	PIN, DOWEL .093 x 3/4 SS	1
-13	465-1046 (6615-131)	VERNIER HUB, PAPER DRIVE	1
-14	461-3184 (6615-124)	SHAFT, VERNIER CLUTCH	1
-15	461-3183 (6615-117)	SHAFT, IDLER	1

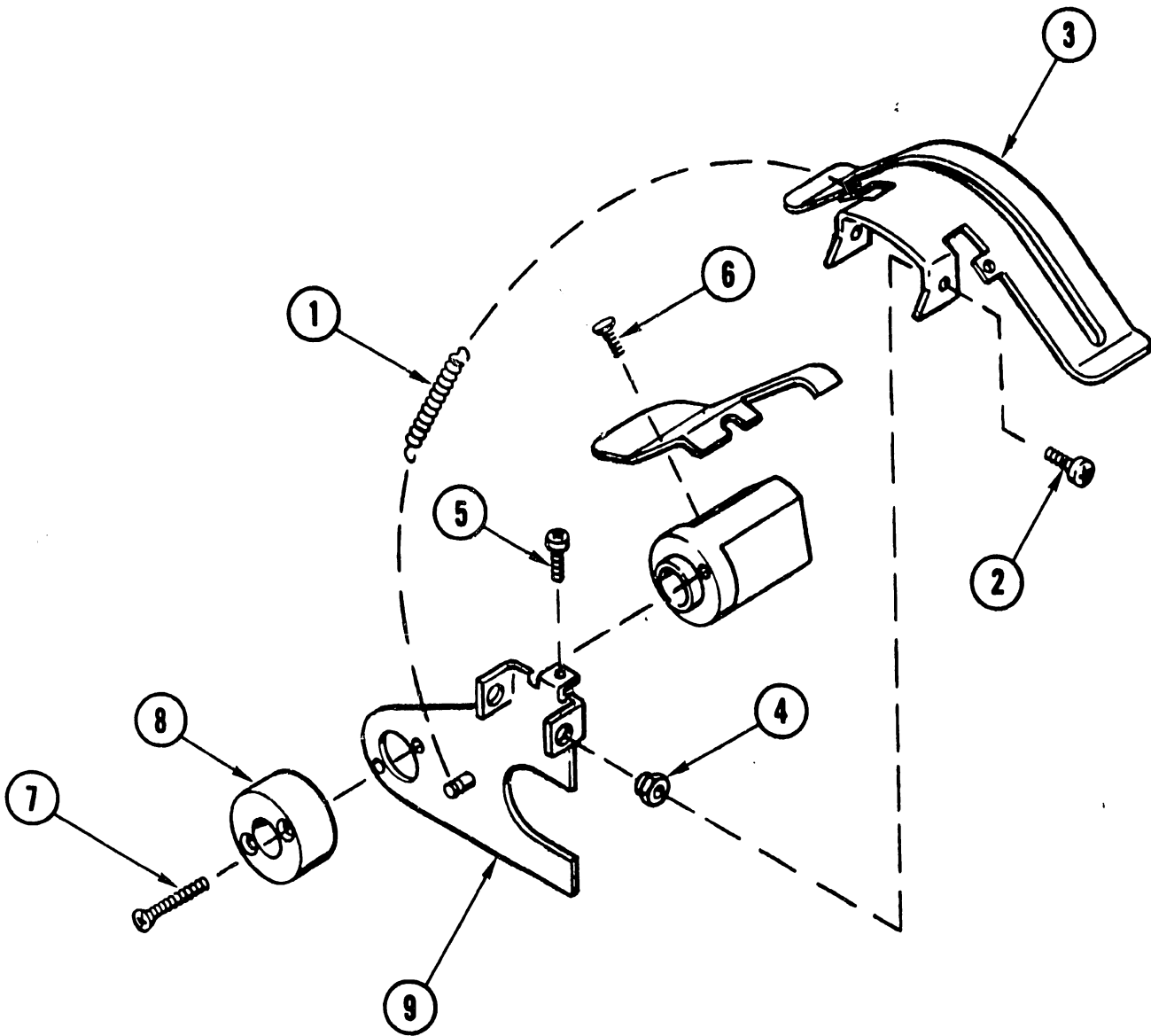

FIGURE 8-5 LEFT & RIGHT HAND PAPER GUIDE COVER ASSEMBLIES

PARTS LIST FOR FIGURE 8-5

ITEM NO.	PART NO.	DESCRIPTION	QTY. PER ASSEMBLY
-	279-5070-38 (6635-38) 279-5070-39 (6635-39)	LEFT & RIGHT HAND PAPER GUIDE COVER ASSEMBLIES	REF
- 1	465-1614	SPRING (LEE 018A-1 MUSIC WIRE)	2
- 2	650-3091	SCREW, #6-32 x 3/4 TRUSS HD PHL SS NYLOK	4
- 3	451-2104 (6635-41)	COVER, PAPER GUIDE	2
- 4	461-3199 (6615-160)	PIVOT, SPROCKET COVER	4
- 5	650-2098	SCREW, #4-40 x 1/4 PAN HD PHL PARKERIZE LONG LOCK	2
- 6	458-0304 (6615-166)	ARM, PAPER LIFT L.H.	1
	458-0305 (6615-166)	ARM, PAPER LIFT R.H.	1
- 7	650-2241	SCREW, #4-40 x 3/4 FLAT HD PHL BLK OX	4
- 8	465-1048 (6615-165)	HUB, SPROCKET LOCKING	2
- 9	279-5070-40 (6635-40)	SIDE PLATE, L.H. ASSEMBLY	1
	279-5070-41 (6635-41)	SIDE PLATE, R.H. ASSEMBLY	1
-10	465-0722	BUSHING, LEFT	1
-11	458-0304	ARM, PAPER LIFT	1

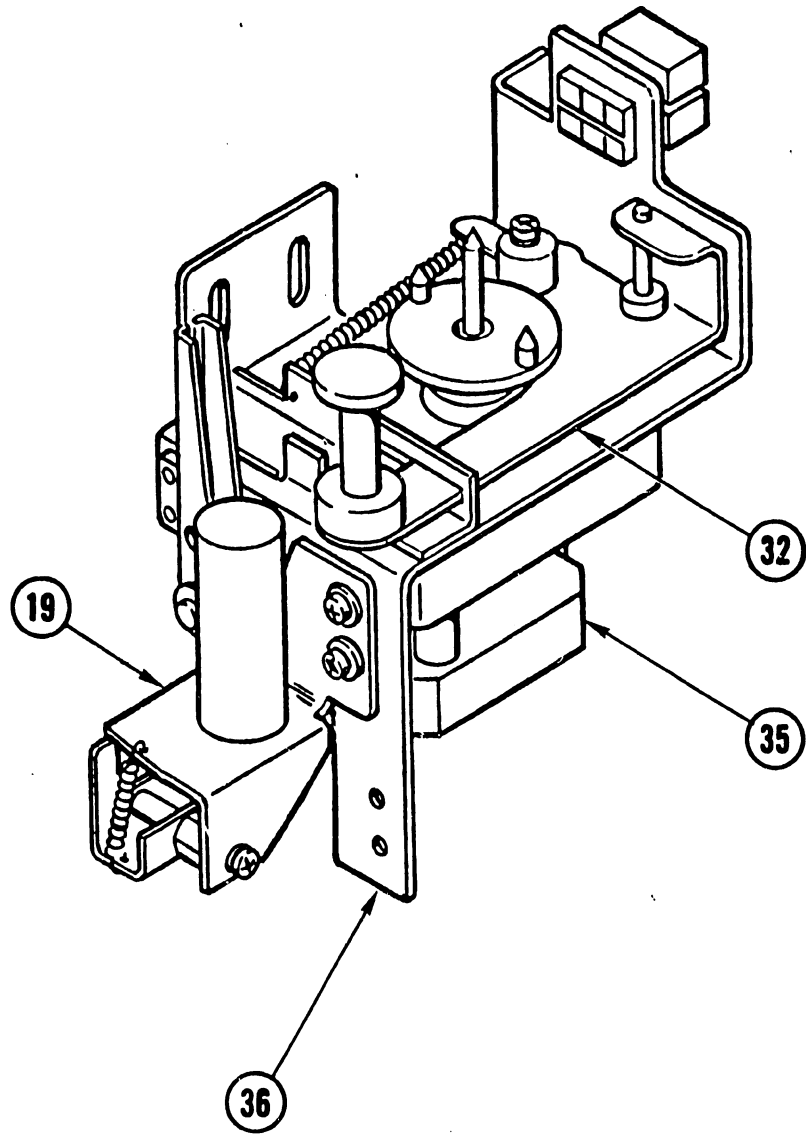

FIGURE 8-6 RIGHT HAND RIBBON FEED ASSEMBLY

PARTS LIST FOR FIGURE 8-6

ITEM NO.	PART NO.	DESCRIPTION	QTY. PER ASSEMBLY
-	279-5070-24 (6635-24)	RIGHT HAND RIBBON FEED ASSEMBLY	REF
- 1	654-1184	HOUSING, 6 POS PIN AMP-1-480276-0	1
- 2	650-0140	SEMS, #2-56 x 7/16 PAN HD PHL SS	2
- 3	325-2309 M (6615-175)	MICROSWITCH (MOD)	1
- 4	615-0334 (5776-733)	INSULATOR, MICROSWITCH	1
- 5	651-1719	SNAP RING, TRUARC 5133-25	1
- 6	458-0300 (6615-86)	ARM, RIBBON REVERSE ACTUATOR	1
- 7	465-0917 (5776-288)	SPRING, TYPE 2 #5	1
- 8	650-4101	SCREW, #8-32 x 5/16 PAN HD PHL	2
- 9	653-4001	WASHER, LOCK #8 INT T	2
-10	653-4000	WASHER, FLAT #8	2
-11	465-0917 (5776-288)	SPRING, TYPE 2 #5	1
-12	651-1504	PIN, ROLL .062 x 3/8	1
-13	651-1712	SNAP RING, TRUARC 5133-18	1
-14	458-0301 (6615-87)	ARM, CLUTCH ENGAGEMENT	1
-15	650-4101	SCREW, #8-32 x 5/16 PAN HD	1
-16	653-4001	WASHER, LOCK #8 INT T	1
-17	461-3192 (6615-109)	STUD, SOLENOID ACTUATOR ARM	1
-18	320-1013	SOLENOID & PLUNGER, TUBULAR	1
-19	451-4316 (6615-149)	BRACKET, R.H. SOLENOID	1
-20	465-0921	SPRING, RIBBON TENSION ARM	1

ITEM NO.	PART NO.	DESCRIPTION	QTY. PER ASSEMBLY
-21	650-6240	SCREW, #10-32 x 3/4 PAN HD PHL SS	2
-22	653-6001	WASHER, LOCK #10 INT T	2
-23	650-0140	SCREW, #4-40 x 1/8 SOC SET BLK OK	1
-24	465-0409 (5996-100)	COLLAR, (MDL 24) SET SCREW	1
-25	650-4161	SCREW, #8-32 x 1/2 FLAT HD PHL SS	1
-26	452-4024 (6615-28)	GUIDE, RIBBON	1
-27	452-4031 (6615-218)	GUIDE, TENSION ARM	1
-28	650-3200	SCREW, #6-32 x 5/8 PAN HD PHL SS	1
-29	653-3001	WASHER, LOCK #6 INT T	1
-30	653-3000	WASHER, FLAT #6	1
-31	458-0302 (6615-108)	STOP, RIBBON SPOOL	1
-32	458-0299 (6615-113)	ARM, RIBBON TENSION, R.H.	1
-33	650-6240	SCREW, #10-32 x 3/4 PAN HD PHL SS	2
-34	653-6001	WASHER, LOCK #10 INT T	2
-35	400-0029 (6615-222)	MOTOR, RIBBON FEED, C.W. ROT	1
-36	279-5070-28 (6635-28)	BRACKET, R.H. RIBBON FEED ASSEMBLY	1

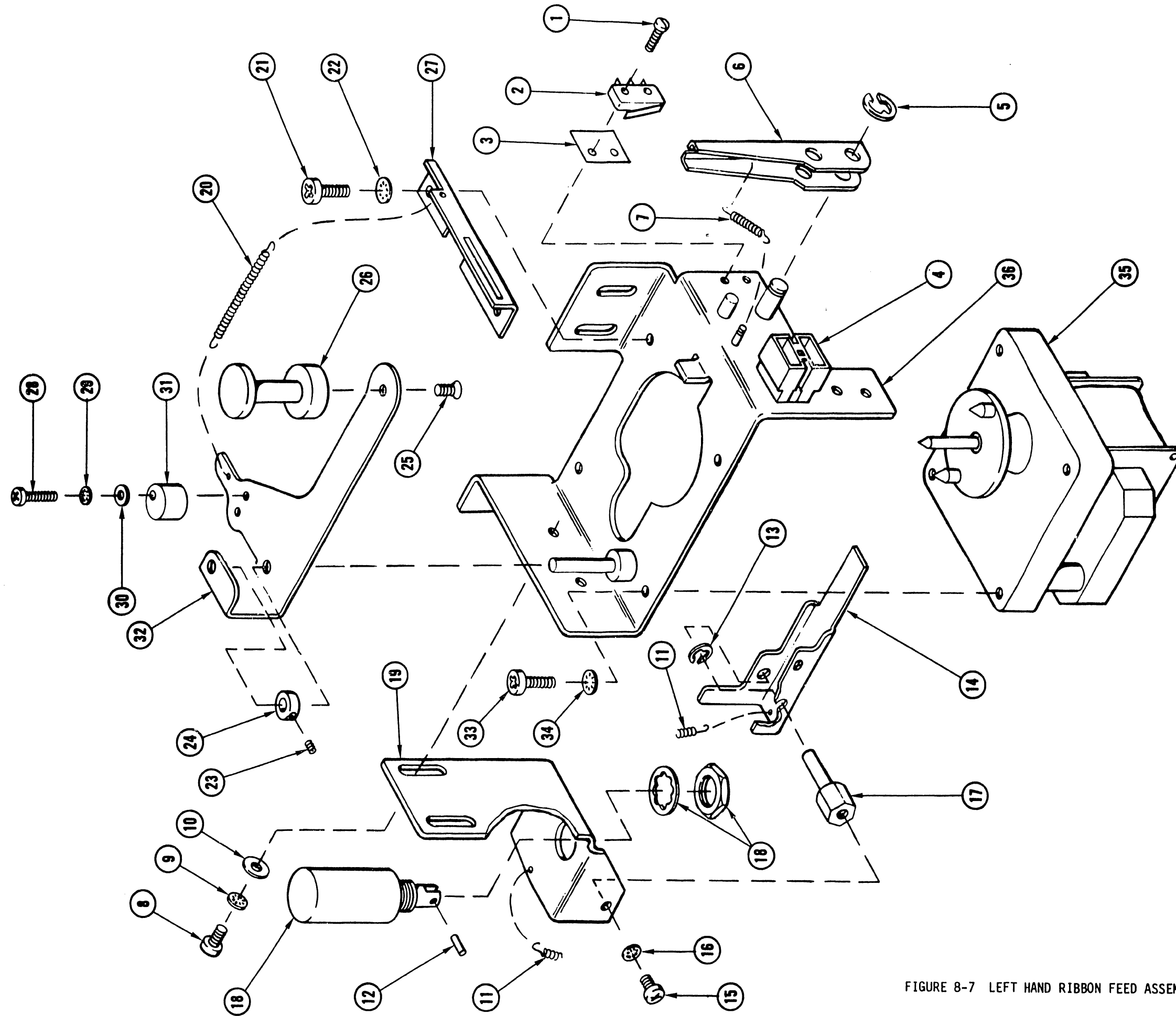

FIGURE 8-7 LEFT HAND RIBBON FEED ASSEMBLY

PARTS LIST FOR FIGURE 8-7

ITEM NO.	PART NO.	DESCRIPTION	QTY. PER ASSEMBLY
-	279-5070-23 (6635-23)	LEFT HAND RIBBON FEED ASSEMBLY	REF
- 1	650-0140	SEMS, #2-56 x 7/16 PAN HD PHL ZINC	2
- 2	325-2309 M (6615-175)	MICROSWITCH (MOD)	1
- 3	615-0334 (5776-733)	INSULATOR, MICROSWITCH	1
- 4	654-1184	HOUSING, 6 POS PIN AMP-1-480276-0	1
- 5	651-1719	SNAP RING, 5133-25 TRUARC	1
- 6	458-0300 (6615-86)	ARM, RIBBON REVERSE ACTUATOR	1
- 7	465-0917 (5776-288)	SPRING, TYPE 2 #5	1
- 8	650-4101	SCREW, #8-32 x 5/16 PAN HD PHL	2
- 9	653-4001	WASHER, LOCK #8 INT T	2
-10	653-4000	WASHER, FLAT #8	2
-11	465-0917 (5778-288)	SPRING, TYPE 2 #5	1
-12	651-1504	PIN, ROLL .062 x 3/8	1
-13	651-1712	SNAP RING, TRUARC 5133-18	1
-14	458-0301 (6615-87)	ARM, CLUTCH ENGAGEMENT	1
-15	650-4101	SCREW, #8-32 x 5/16 PAN HD PHL	1
-16	653-4001	WASHER, LOCK #8 INT T	1
-17	461-3192 (6615-109)	STUD, SOLENOID ACTUATOR ARM	1
-18	320-1013	SOLENOID & PLUNGER, TUBULAR	1
-19	451-4315 (6615-114)	BRACKET, L.H. SOLENOID	1
-20	465-0921	SPRING, RIBBON TENSION ARM	1

ITEM NO.	PART NO.	DESCRIPTION	QTY. PER ASSEMBLY
-21	650-6240	SCREW, #10-32 x 3/4 PAN HD PHL SS	2
-22	653-6001	WASHER, LOCK #10 INT T	2
-23	650-2040	SCREW, #4-40 x 1/8 SOC SET BLK OX	1
-24	465-0409 (5996-100)	COLLAR, (MDL 24) SET SCREW	1
-25	650-4161	SCREW, #8-32 x 1/2 FLAT HD PHL SS	1
-26	452-4024 (6615-28)	GUIDE, RIBBON	1
-27	452-4031 (6615-218)	GUIDE, TENSION ARM	1
-28	650-3200	SCREW, #6-32 x 5/8 PAN HD PHL SS	1
-29	653-3001	WASHER, LOCK #6 INT T	1
-30	653-3000	WASHER, FLAT #6	1
-31	458-0302 (6615-108)	STOP, RIBBON SPOOL	1
-32	458-0298 (6615-113)	ARM, RIBBON TENSION	1
-33	650-6240	SCREW, #10-32 x 3/4 PAN HD PHL SS	2
-34	653-6001	WASHER, LOCK #10 INT T	2
-35	400-0030 (6615-222)	MOTOR, RIBBON FEED, C.R.W. ROT	1
-36	279-5070-27 (6635-27)	BRACKET, L.H. RIBBON FEED ASSEMBLY	1

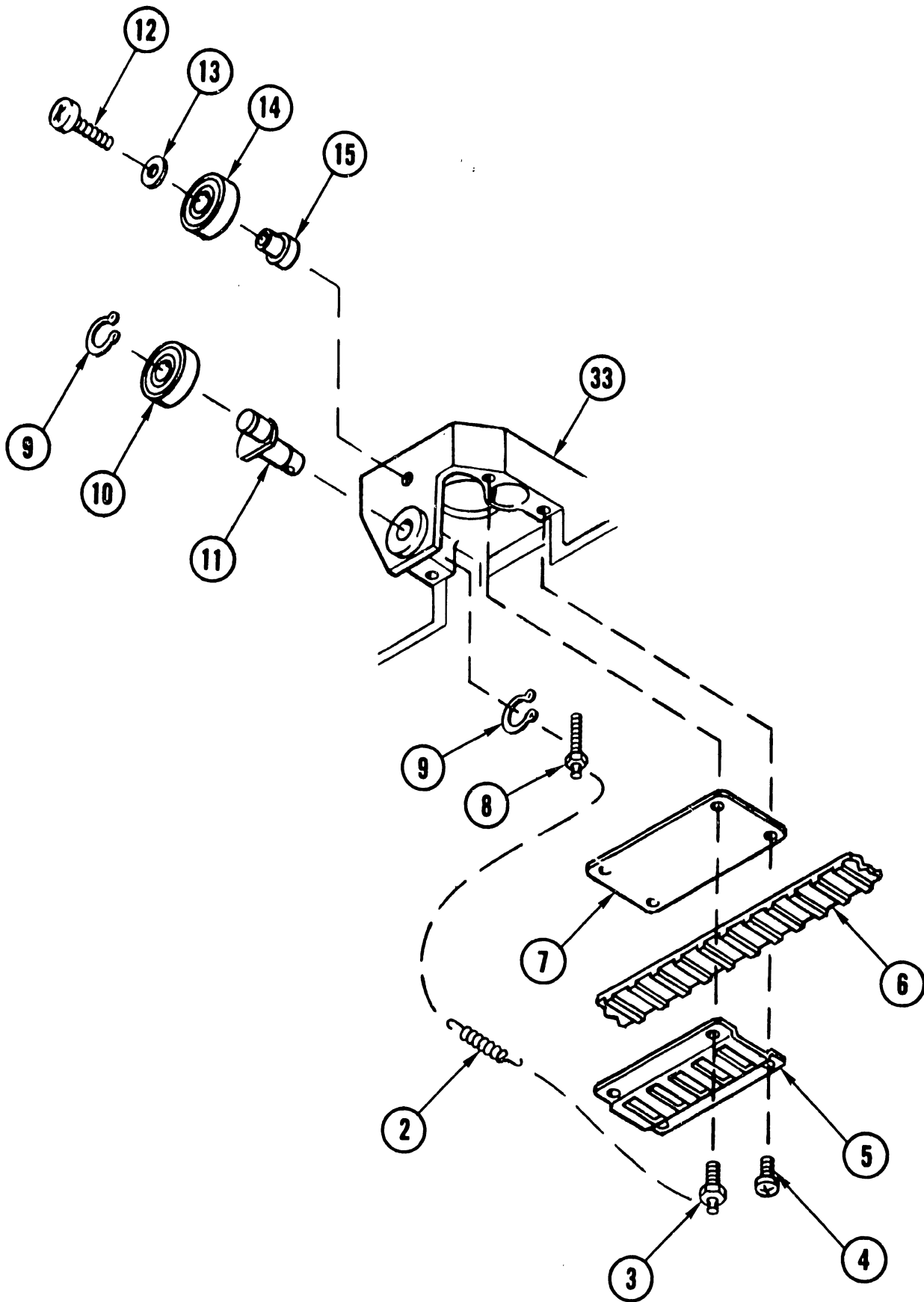

FIGURE 8-8 CARRIAGE ASSEMBLY SHEET 1 OF 3

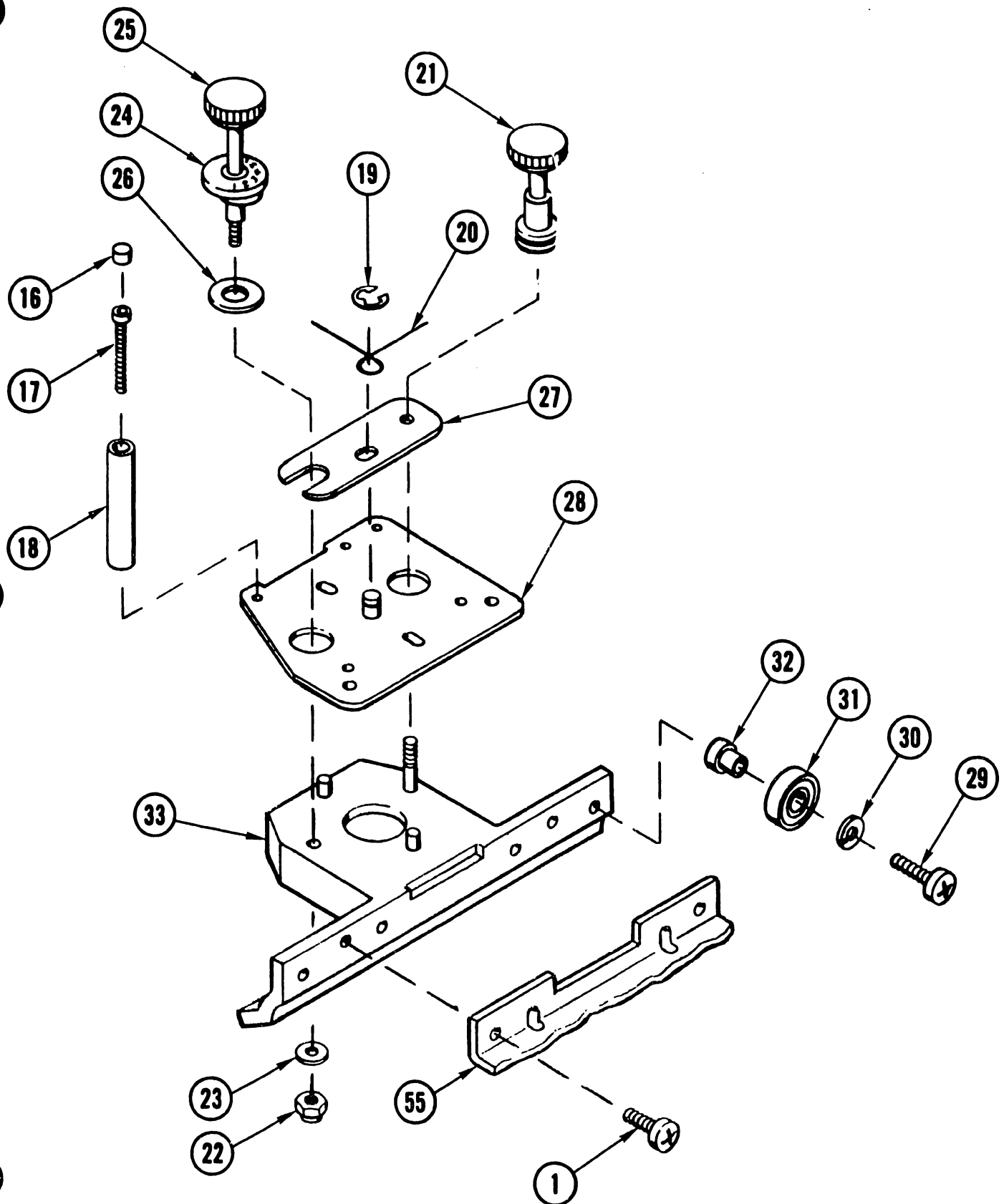

FIGURE 8-8 CARRIAGE ASSEMBLY SHEET 2 OF 3

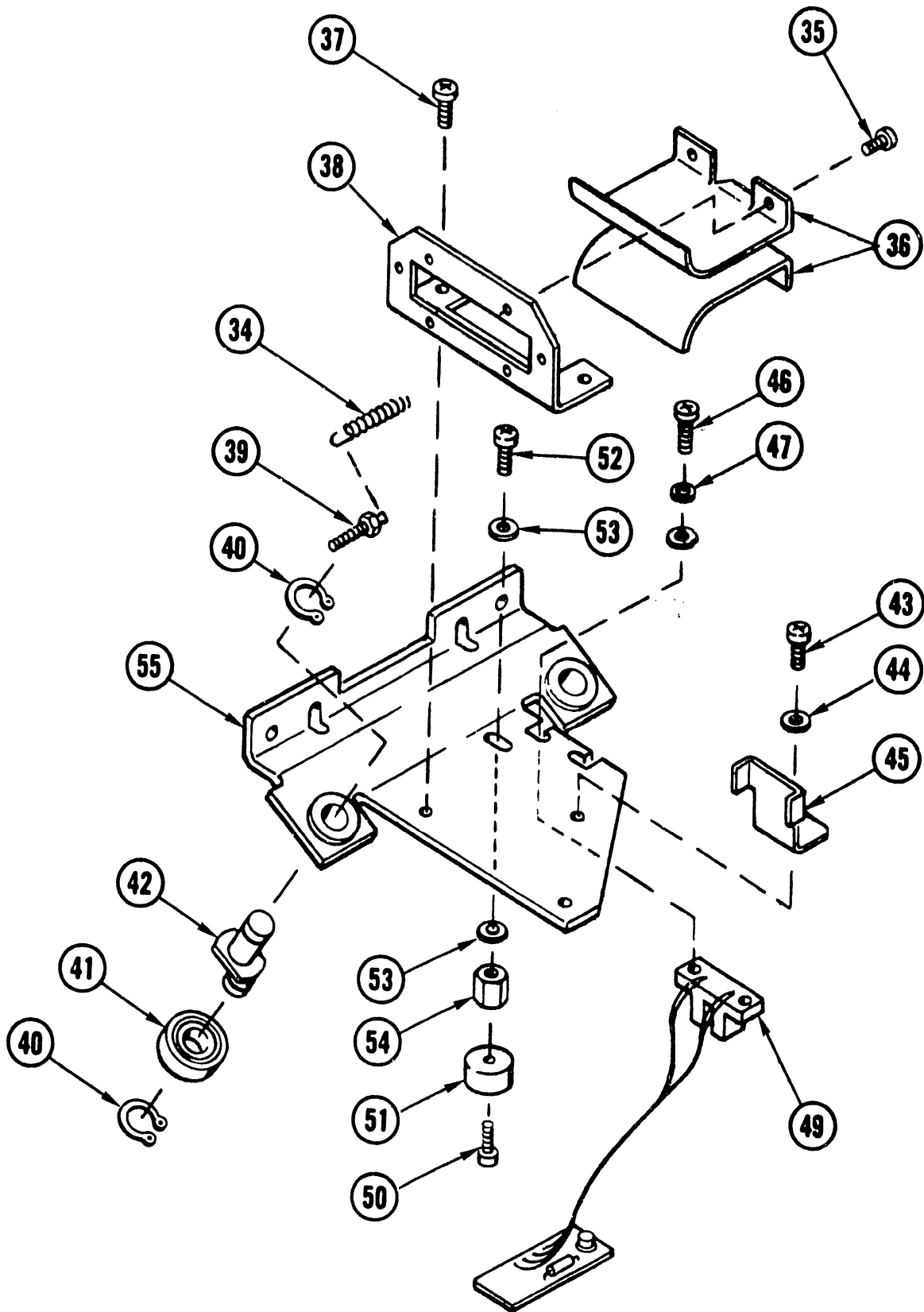

FIGURE 8-8 CARRIAGE ASSEMBLY SHEET 3 OF 3

PARTS LIST FOR FIGURE 8-8

ITEM NO.	PART NO.	DESCRIPTION	QTY. PER ASSEMBLY
-	279-5070-19	CARRIAGE ASSEMBLY	REF
- 1	650-4120	SEMS, #8-32 x 3/8 PAN HD PHL SS	4
- 2	465-1618	SPRING, LEE LE-016A-001 (MUSIC WIRE)	1
- 3	478-0266 (6615-68)	SPRING HANGER	1
- 4	650-3120	SEMS, #6-32 x 3/8	3
- 5	452-2549 (6615-73)	CLAMP, BELT	1
- 6	656-0220	BELT, TIMING (GOOD YEAR 420L050)	1
- 7	452-2134 (6615-75)	BACKING PLATE	1
- 8	461-3178 (6615-146)	SPRING PIN CARRIAGE ECCENTRIC	1
- 9	651-1727	RETAINING RING, (741) CRESL (TRUARC 5103-25)	2
-10	465-0012	BEARING, BALL SR 4PP	1
-11	458-0294 (6615-69)	ECCENTRIC, BEARING MOUNT	1
-12	650-4200	SCREW, #8-32 x 5/8 PAN HD PHL SS	1
-13	653-4001	WASHER, LOCK #8 INT T	1
-14	465-0012	BEARING, BALL SR 4PP	1
-15	461-3172 (6615-72)	STUD, CARRIAGE BEARING	1
-16	655-0232	HOLE PLUG, HEYCO P-250	3
-17	650-3321	SCREW, #6-32 x 1" SOC HD CAP	3
-18	452-4022 (6615-67)	GUIDE, CARRIAGE RIBBON	3
-19	651-1712	SNAP RING, 5133-18	1
-20	465-1609 (6615-65)	SPRING, HEAD	1

ITEM NO.	PART NO.	DESCRIPTION	QTY. PER ASSEMBLY
-21	461-3168 (6615-41)	SHAFT, LOCKING KNOB	1
-22	652-0046	NUT, STOP #8-32 ELASTIC 22NM82	1
-23	653-4000	WASHER, FLAT #8	1
-24	461-1033 (6615-242)	DISC, HEAD ADJUSTING INDICATOR	1
-25	461-3169 (6615-42)	SHAFT, HEAD ADJUST	1
-26	461-3174 (6615-63)	WASHER	1
-27	452-2139 (6615-49)	PLATE, HEAD LOCKING	1
-28	279-5070-21 (6635-21)	PLATE, HEAD MOUNTING ASSEMBLY	1
-29	650-4200	SCREW, #8-32 x 5/8 PAN HD PHL SS	4
-30	653-4001	WASHER, LOCK #8 INT T	4
-31	465-0012	BEARING, BALL SR 4PP	4
-32	461-3172 (6615-72)	STUD, CARRIAGE BEARING	4
-33	279-5070-20 (6635-20)	CARRIAGE, CASTING ASSEMBLY (PRESSING)	1
-34	465-1615	SPRING, LEE 022B-8 (MUSIC WIRE)	1
-35	650-2060	SEMS, #4-40 x 3/16 PAN HD PHL SS	4
-36	452-4023 (6615-142)	GUIDE, HEAD CONNECTOR	2
-37	650-3080	SEMS, #6-32 x 1/4 PAN HD PHL SS	2
-38	451-4310 (6615-140)	BRACKET, CONNECTOR MOUNTING	1
-39	461-3178 (6615-146)	SPRING PIN CARRIAGE ECCENTRIC	2
-40	651-1727	RETAINING RING (741) CRESL (TRUARC 5103-25)	4
-41	465-0012	BEARING, BALL SR 4PP	2

ITEM NO.	PART NO.	DESCRIPTION	QTY. PER ASSEMBLY
-42	458-0294 (6615-69)	ECCENTRIC BEARING MOUNT	2
-43	650-3120	SEMS, #6-32 x 3/8 PAN HD PHL SS	1
-44	653-3000	WASHER, FLAT #6	1
-45	458-0293 (6615-141)	RETAINER, FINGERBOARD	1
-46	650-2902	SCREW, #5-40 x 5/16 PAN HD PHL SS	2
-47	653-2501	WASHER, LOCK #5 INT T	2
-48	653-2500	WASHER, FLAT #5	2
-49	210-6573	MODULE, 6573 (PHOTOCELL)	1
-50	650-1082	SCREW, #3-48 x 1/4 SOC HD CAP	1
-51	656-1006	MAGNET, ARNOLD IG SU1611	1
-52	650-3120	SEMS, #6-32 x 3/8 PAN HD PHL SS	1
-53	653-3000	WASHER, FLAT #6	2
-54	462-0225 (6615-150)	MAGNET HOLDER STAND OFF MAGNET MOUNTING	1
-55	279-5070-22 (6635-22)	BRACKET, OUT BOARD BEARING (PRESSING)	1

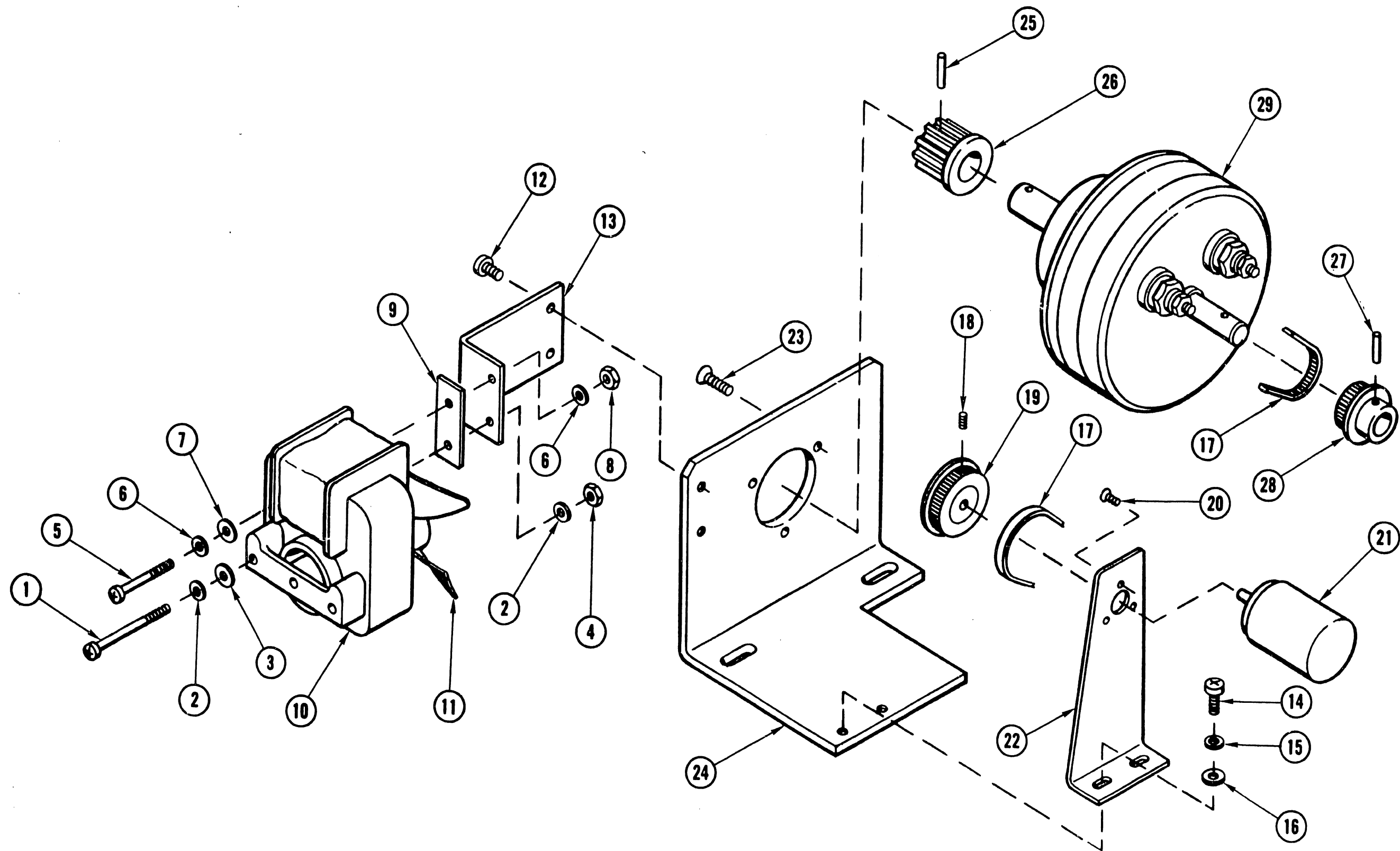

FIGURE 8-9 CARRIAGE DRIVE & TACHOMETER ASSEMBLY

PARTS LIST FOR FIGURE 8-9

ITEM NO.	PART NO.	DESCRIPTION	QTY. PER ASSEMBLY
-	279-5070-17 (6635-17)	CARRIAGE DRIVE & TACHOMETER ASSEMBLY	REF
- 1	650-3322	SCREW, #6-32 x 1-1/2 PAN HD PHL SS	1
- 2	653-3001	WASHER, LOCK #6 INT TOOTH	2
- 3	653-3000	WASHER, FLAT #6	1
- 4	652-3000	NUT, HEX #6-32	1
- 5	650-3320	SCREW, #6-32 x 1" PAN HD PHL SS	1
- 6	653-3001	WASHER, LOCK #6 INT TOOTH	2
- 7	653-3000	WASHER, FLAT #6	1
- 8	652-3000	NUT, HEX #6-32 SS	1
- 9	458-0319 (6615-240)	SHOCK MOUNT, FAN	1
-10	400-0020 (5996-113)	MOTOR AIRTRL 11-9201	1
-11	400-9004	FAN BLADE, 3" PLASTIC	1
-12	650-6160	SEMS, #10-32 x 1/2 PAN HD PHL SS	2
-13	458-0318 (6615-192)	MOUNT, CARRIAGE DRIVE COOLING FAN	1
-14	650-6121	SCREW, #10 x 32 PAN HD PHL SS	2
-15	653-6001	WASHER, LOCK #10 INT TOOTH	2
-16	653-6000	WASHER, FLAT #10	2
-17	656-0223	BELT, 65M x 1/8 W 4DP	1
-18	650-2093	SCREW, #4-40 x 1/4 SOC SET CUP POINT	1
-19	478-0288 (6615-190)	PULLEY, TACHOMETER	1
-20	650-9505	SCREW, M2 x 5 MM .4 PITCH FLAT HD SLOTTED	3

ITEM NO.	PART NO.	DESCRIPTION	QTY. PER ASSEMBLY
-21	400-0028	MOTOR, 12 VDC NAPC 9904-120-12601	1
-22	451-4415	BRACKET, TACHOMETER	1
-23	650-6161	SCREW, #10-32 x 1/2 FLAT HD SS	3
-24	451-4302	BRACKET, MOTOR	1
-25	651-1509	PIN, ROLL .093 x 1/2	1
-26	478-0276	PULLEY, 3 OLT-187 .375 BORE	1
-27	651-1527	ROLL PIN, 5/32 x 11/16 SS	1
-28	478-0261 (6615-112)	PULLEY, CARRIAGE DRIVE	1
-29	400-0024 (6615-100)	MOTOR, CARRIAGE DRIVE (MP)	1

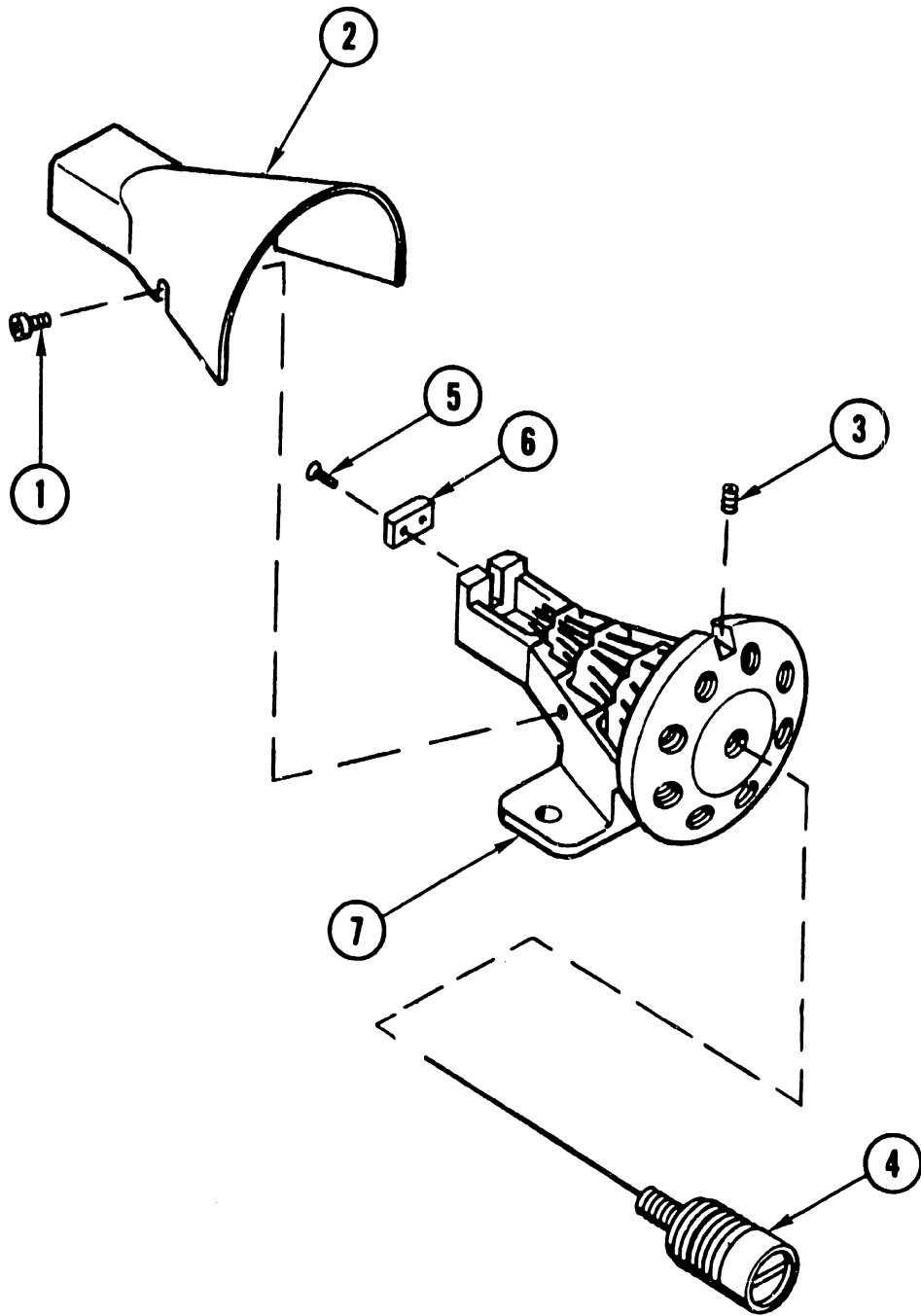

FIGURE 8-10 HEAD ASSEMBLY

PARTS LIST FOR FIGURE 8-10

ITEM NO.	PART NO.	DESCRIPTION	QTY. PER ASSEMBLY
-	279-5070-12 (6635-12)	HEAD ASSEMBLY (MOD 72)	REF
- 1	650-2098	SCREW, #4-40 x 1/4 PAN HD PHL LONG LOCK PARKERIZE	2
- 2	449-0102 (6615-230)	COVER, PRINT HEAD	1
- 3	650-4070	SCREW, #8-32 x 7/32 SOC SET BRASS TIP	9
- 4	279-5070-14	PRINT SOLENOID/BODY & GUIDE TUBE ASSEMBLY	9
- 5	650-0064	SCREW, #00-90 x 3/16 FLAT HD SS	2
- 6	465-0240 (6615-92)	BEARING, MP-72 PRINT HEAD	1
- 7	279-5070-13 (6635-13)	HEAD & GUIDE TUBE ASSEMBLY	1

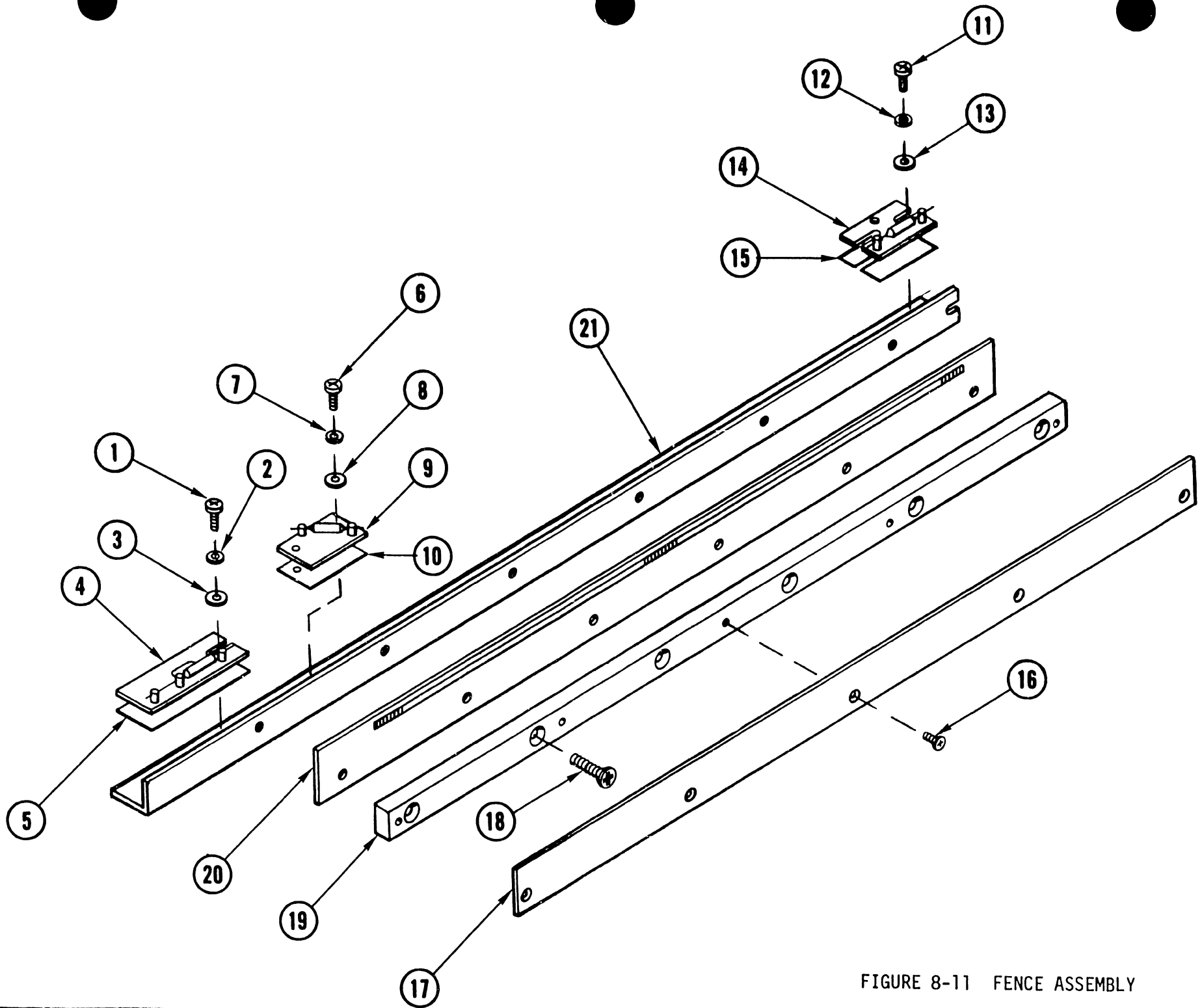

FIGURE 8-11 FENCE ASSEMBLY

PARTS LIST FOR FIGURE 8-11

ITEM NO.	PART NO.	DESCRIPTION	QTY. PER ASSEMBLY
-	279-5070-46 (6635-46)	FENCE, MOD-72 ASSY	REF
- 1	650-2088	SCREW, #4-40 x 1/4 PAN HD PHL SS	2
- 2	653-2002	WASHER, LOCK #4 INT T	2
- 3	653-2000	WASHER, FLAT #4	2
- 4	310-0017 (6615-236)	TERMINAL BOARD SW 0	1
- 5	615-0368 (6615-152)	INSULATOR, SWITCH BOARD	1
- 6	650-2088	SCREW, #4-40 x 1/4 PAN HD PHL SS	2
- 7	653-2002	WASHER, LOCK #4 INT T	2
- 8	653-2000	WASHER, FLAT #4	2
- 9	310-0016 (6615-182)	TERMINAL BOARD, SW 1	1
-10	615-0368 (6615-152)	INSULATOR, SWITCH BOARD	1
-11	650-2088	SCREW, #4-40 x 1/4 PAN HD PHL SS	2
-12	653-2002	WASHER LOCK #4 INT T	2
-13	653-2000	WASHER FLAT #4	2
-14	310-0015 (6615-151)	TERMINAL BOARD SW 2	1
-15	615-0368 (6615-152)	INSULATOR, SWITCH BOARD	1
-16	650-2081	SCREW, #4-40 x 1/4 FLAT HD PHL	5
-17	452-3530 (6615-171)	SHIELD, ENCODER FENCE	1
-18	650-4161	SCREW, #8-32 x 1/2 FLAT HD PHL SS	6
-19	458-0292 (6615-52)	FENCE SUPPORT STRIP	1

ITEM NO.	PART NO.	DESCRIPTION	QTY. PER ASSEMBLY
-20	461-1031 (6615-225)	ENCODER 5.5 SPACE	1
-21	451-4311	BRACKET, ENCODER FENCE MOUNTING	1

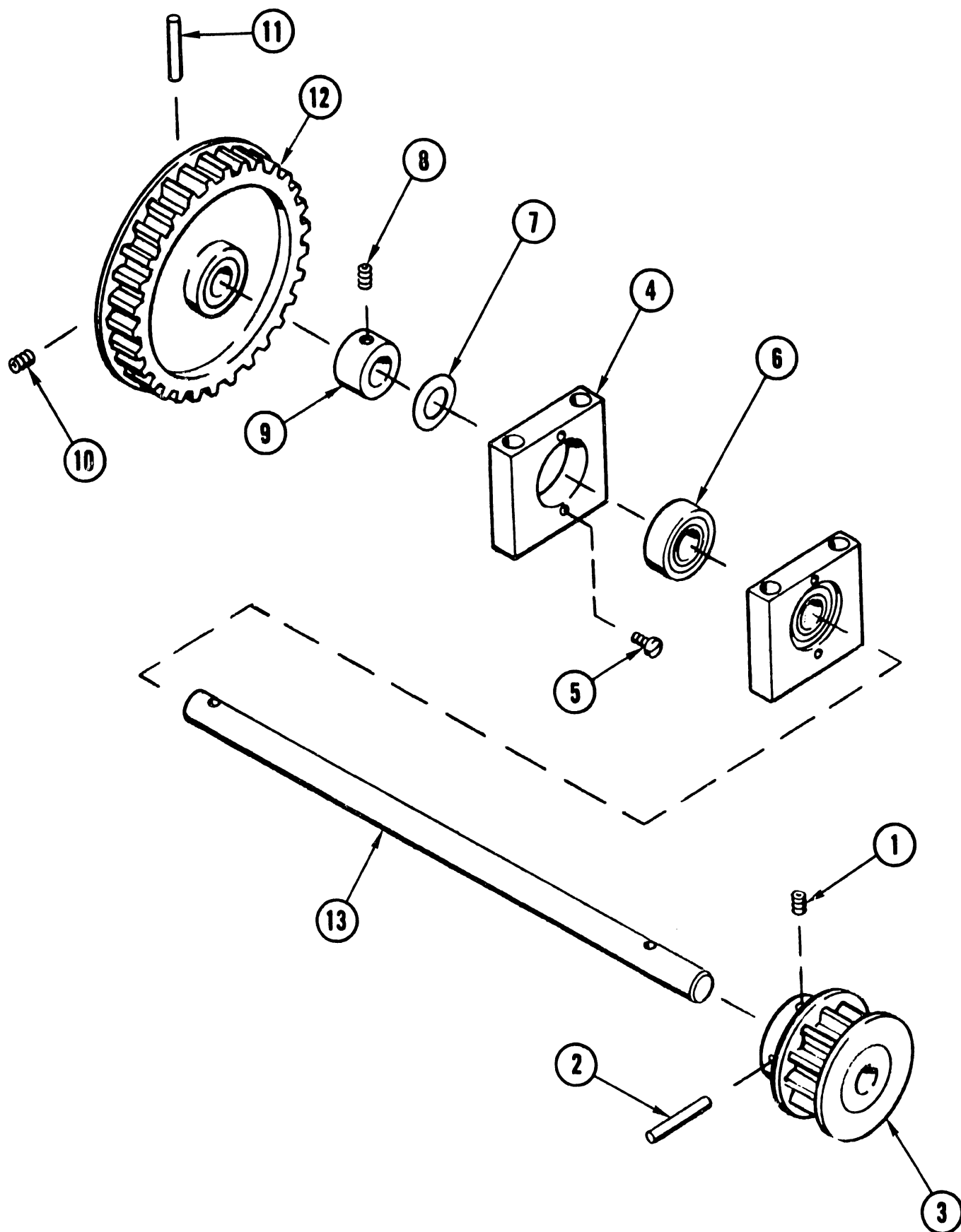

FIGURE 8-12 CARRIAGE DRIVE SHAFT & BEARING HOUSING ASSEMBLY

PARTS LIST FOR FIGURE 8-12

ITEM NO.	PART NO.	DESCRIPTION	QTY. PER ASSEMBLY
-	279-5070-45 (6635-45)	CARRIAGE DRIVE SHAFT & BEARING HOUSING ASSEMBLY	REF
- 1	NOT USED		1
- 2	651-1526	SPIRAL PIN, .093 x 7/8 SS	1
- 3	478-0278 (6615-176)	PULLEY, CARRIAGE DRIVE	1
- 4	461-3173 (6615-96)	HOUSING, BEARING	2
- 5	650-3124	SCREW, #6-32 x 3/8 TRUSS HD PHL SS	4
- 6	465-0011	BEARING BALL SR61PPD	2
- 7	653-0035	WASHER, WAVE SPRING (ASC #W0484-009)	1
- 8		SCREW, #1/4-20 x 3/16 SOC SET CUP PT NYLOK	1
- 9	465-0416	COLLAR 3/8 SHAFT	1
-10	NOT USED		1
-11	651-1529	SPIRAL PIN, .093 x 1.25 SS	1
-12	478-0274 (6615-168)	PULLEY, 48T - 1/5P	1
	660-0106	CEMENT, LOCTITE 1S06	AR

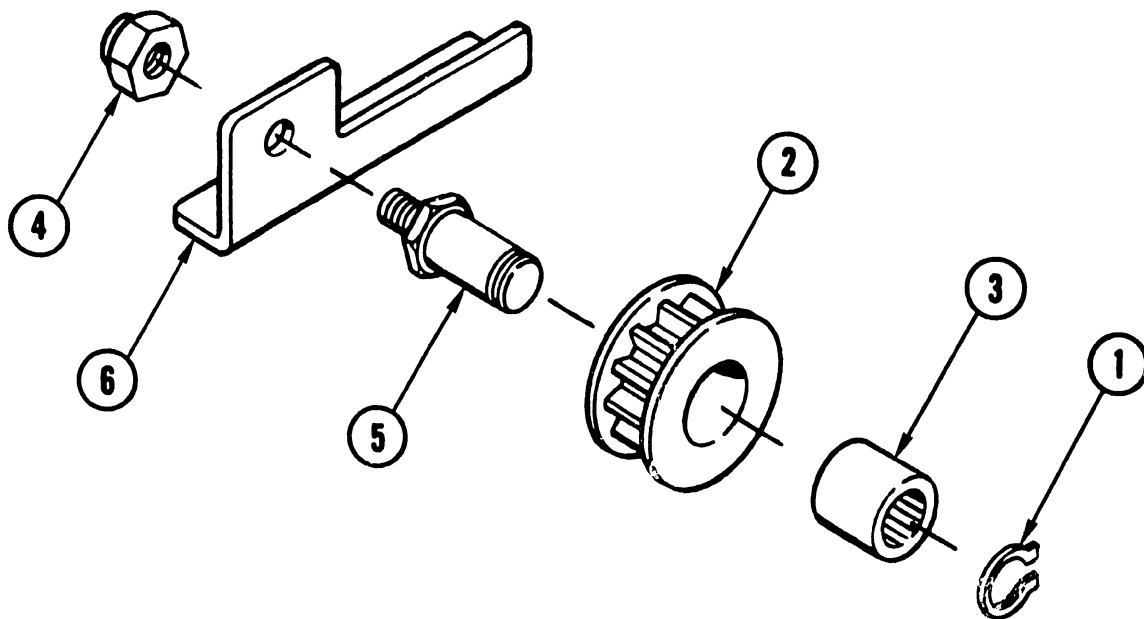

FIGURE 8-13 IDLER PULLEY & BRACKET ASSEMBLY

PARTS LIST FOR FIGURE 8-13

ITEM NO.	PART NO.	DESCRIPTION	QTY. PER ASSEMBLY
-		IDLER PULLEY & BRACKET ASSEMBLY	REF
- 1	651-1740	RETAINING RING, TRUARC 5100-50	1
- 2	478-0262 (6615-120)	PULLEY, IDLER	1
- 3	465-0238	BEARING, ROLLER (TORRINGTON JH-812-011)	1
- 4	652-0054	NUT, STOP 5/16 ESNA 18 ZINTE 058	1
- 5	461-3171 (6615-32)	STUD, IDLER PULLEY	1
- 6	451-4301 (6615-33)	BRACKET, IDLER PULLEY	1

APPENDIX

A

PAPER

SPECIFI-

CATIONS

APPENDIX A
PAPER SPECIFICATIONS

If paper does not conform to these specifications, degraded forms handling can occur. No specifications are given for card stock; try a sample before purchasing.

1. Material must be margin-perforated fanfold paper or card stock, perforations are used for guiding by pin-feed units.
2. Maximum form length is not to exceed 11 in. (27.9 cm).
3. Paper Stock:
 - a. for single part forms use 15 to 20 lb bond (20 lb for improved forms handling)
 - b. for multipart forms use:
 - 2 ply: 15/15 lb bond, 7 lb carbon
 - 3 ply: 15/12/15 lb bond, 7 lb carbon
 - 4 ply: 12/12/12/15 lb bond, 7 lb carbon
 - 5 ply: 12/12/12/12/15 lb bond, 5 lb carbon(up to four copies in addition to the original can be used)
 - c. form width must be:
 - 5 in. (12.7 cm) minimum
 - 14 7/8 in. (37.8 cm) maximum
4. Fastening of multipart forms:
 - a. improved multipart paper handling can be achieved with glued margins
 - b. multipart forms must otherwise be fastened with crimps every two inches (5.1 cm) along both edges of the forms.

- c. crimps must not come closer to the fanfold than 0.50 in. (1.27 cm)
 - d. each crimp must have four prongs, two to enter both form and carbon and two to enter forms only.
5. Forms thickness:
- a. maximum in the print area: 0.018 in. (0.046 cm) allows for four 12 lb, one 15 lb and four 7 lb carbon parts.
 - b. over crimps in the pin-feed margin: 0.030 in. (0.076 cm)
6. Sprocket holes:
- a. must run along both margins $0.25 \pm .03$ in. (0.635 ± 0.076 cm) from paper edge to the hole center lines
 - b. distance between hole centers along the margins must be 0.5 ± 0.005 in. (1.27 ± 0.013 cm) non-accumulative in any five in. (12.7 cm) length
 - c. hole diameters must be 0.156 ± 0.005 in. (0.396 ± 0.013 cm) the two top and bottom drive holes on each sheet (four per sheet) can be up to 0.200 in. (0.508 cm) in diameter to permit post or ring binding of output.
 - d. distance between hole centers across the sheet must be uniform without 0.015 in. (0.038 cm) to a maximum of 14-1/2 in. (36.83 cm)
7. When using forms with wide and narrow copies in the same set, the top copy should always be fullest width.
8. For pre-printed forms:
- pin-hole center to left side of left-most character not less than $3/8 \pm 1/16$ in. (1.0 ± 0.2 cm)
 - pin-hole center to right side of last character not less than $3/8 \pm 1/16$ in. (1.0 ± 0.2 cm)

APPENDIX

B

HEXA-

DECIMAL

CODES

APPENDIX
HEXADECIMAL CODES

HEX CODE	PRINTER CHARACTER	HEX CODE	PRINTER CHARACTER	HEX CODE	PRINTER CHARACTER
HEX(07)	Alarm	HEX(3D)	=	HEX(60)	`
HEX(0A)	Line Feed	HEX(3E)	>	HEX(61)	a
HEX(0B)	Vertical Tab	HEX(3F)	?	HEX(62)	b
HEX(0C)	Form Feed	HEX(40)	@	HEX(63)	c
HEX(0D)	Carriage Return	HEX(41)	A	HEX(64)	d
HEX(0E)	Elongated Character	HEX(42)	B	HEX(65)	e
HEX(20)	Space	HEX(43)	C	HEX(66)	f
HEX(21)	!	HEX(44)	D	HEX(67)	g
HEX(22)	"	HEX(45)	E	HEX(68)	h
HEX(23)	#	HEX(46)	F	HEX(69)	i
HEX(24)	\$	HEX(47)	G	HEX(6A)	j
HEX(25)	%	HEX(48)	H	HEX(6B)	k
HEX(26)	&	HEX(49)	I	HEX(6C)	l
HEX(27)	'	HEX(4A)	J	HEX(6D)	m
HEX(28)	(HEX(4B)	K	HEX(6E)	n
HEX(29))	HEX(4C)	L	HEX(6F)	o
HEX(2A)	*	HEX(4D)	M	HEX(70)	p
HEX(2B)	+	HEX(4E)	N	HEX(71)	q
HEX(2C)	,	HEX(4F)	O	HEX(72)	r
HEX(2D)	-	HEX(50)	P	HEX(73)	s
HEX(2E)	.	HEX(51)	Q	HEX(74)	t
HEX(2F)	/	HEX(52)	R	HEX(75)	u
HEX(30)	0	HEX(53)	S	HEX(76)	v
HEX(31)	1	HEX(54)	T	HEX(77)	w
HEX(32)	2	HEX(55)	U	HEX(78)	x
HEX(33)	3	HEX(56)	V	HEX(79)	y
HEX(34)	4	HEX(57)	W	HEX(7A)	z
HEX(35)	5	HEX(58)	X	HEX(7B)	{
HEX(36)	6	HEX(59)	Y	HEX(7C)	!
HEX(37)	7	HEX(5A)	Z	HEX(7D)	}
HEX(38)	8	HEX(5B)	[HEX(7E)	~
HEX(39)	9	HEX(5C)	\	*HEX(7F)	
HEX(3A)	:	HEX(5D)]		
HEX(3B)	;	HEX(5E)	†		
HEX(3C)	<	HEX(5F)	—		

*ASCII DEL, a non-printable control character

APPENDIX

C

SIGNAL

MNE-

MONICS

APPENDIX C
SIGNAL MNEMONICS

SIGNAL	DEFINITION
01-09	9-bit output of character generator ROMs
+9V(sw)	+9 volts switched
+12V(sw)	+12 volts switched
-12V(sw)	-12 volts switched
a	Stepping motor driver collector (\overline{AY})
$A_1 - A_9$	Address bits of ROMs
\overline{AKDLY}	Acknowledge delay
\overline{ACKLG}	Acknowledge at I/O interface
Alarm Light	Fault indicator
\overline{AR}	Read strobe for ROM
AY, \overline{AY}	Base of stepping motor driver
b	Stepping motor driver collector (BY)
$b_1 - b_7$	Output of shift registers
\overline{BELP}	Audio function pulse
\overline{BUSY}	Device busy status for I/O
BY, \overline{BY}	Base of stepping motor drivers
c	Stepping motor driver collector (AY)
\overline{CF}	Carriage forward
\overline{CFM}	Carriage forward maintenance switch
\overline{CIP}	Control input prime
CLCR	Clear carriage return
CLK	System clock
\overline{CLR}	System clear
\overline{CLRM}	Manual clear switch
Common	Common of stepping motor
Cover Open	Cover open switch
\overline{CR}_a	Carriage return flip-flop
\overline{CR}_b	Pulse from \overline{CR}_e to initiate carriage return
\overline{CR}_d	Carriage return decoded
\overline{CR}_e	Carriage return decoded at shift register output
d	Stepping motor driver collector (\overline{BY})
D+	Fence LED anode

SIGNAL

DEFINITION

<u>DELP</u>	Delete function pulse
DT1 - DT7	Data input at I/O interface
<u>DTSB</u>	Data strobe at I/O interface
EC	Expanded character
<u>Fault</u>	Fault status at I/O interface
<u>FC</u>	Function control
FFD+	Form feed LED anode
<u>FFM</u>	Form feed manual switch
<u>FFP</u>	Form feed pulse
FFPE	Form feed phototransistor emitter
<u>Form Override</u>	Form override switch
<u>FT</u>	Form and tab
IP	Input prime at I/O interface
<u>LFD</u>	Line feed delay
<u>LFE</u>	One line count
<u>LFM</u>	Line feed manual switch
<u>LFP</u>	Line feed pulse
<u>Malfunction</u>	Fault indicator
MD	Motor drive common
MDB+	Forward motor drive transistor base
MDB-	Reverse motor drive transistor base
MK	Marker bit
MKR	Marker bit latch
MS1	End of ribbon switch (right)
MS2	End of ribbon switch (left)
OI ₁ - OI ₃	Output inhibits for ROMs
OSCXT	System clock at I/O interface
<u>Paper Out Light</u>	Paper out indicator
<u>Paper Out Sw</u>	Paper out switch
PE	Fence phototransistor emitter
PED+	End of page eject LED anode
PEPE	End of page phototransistor emitter
PF	Paper Feed

SIGNAL

DEFINITION

PFB	Base of paper feed driver transistor
PO	Paper out status at I/O interface
<u>Power-On-Prime</u>	Power on prime pulse
<u>PS</u>	Printable signal
RB	Start ribbon motor
RD	Ribbon drive
RDY/BSY	Ready/Busy (low for busy)
<u>RS</u>	Ready to start printing
RS1	Ribbon driver aiding solenoid (left)
RS2	Ribbon driver aiding solenoid (right)
RT1	Ribbon motor triac (left)
RT2	Ribbon motor triac (right)
S1'-S9'	Base of solenoid drivers
S1C-S9C	Collector of solenoid drivers
S1R-S9R	
Select Light	Select indicator
Select Sw	Select switch
<u>SF6</u>	Shift out next character
SFK	Shift in pulse
<u>SFM</u>	Start forward motion
SL	Select latch
SLCT	Select status at I/O interface
SLCTR	Select control
SPKR	Speaker signal
SW0	Home position switch
SW1	Deceleration switch
SW2	Return switch
Tach+	Feedback tachometer positive
Tach-	Feedback tachometer negative
Time-Meter (RTM)	Elapsed time meter
VR5B	+5 volt regulator base
VR12B	+12 volt regulator base
VTD+	Vertical tab LED anode
<u>VTP</u>	Vertical tab pulse
VTPE	Vertical tab phototransistor emitter
WS	Window strobe from fence

APPENDIX

D

MODEL 72

HEXIDECIMAL

CODED CHARACTER

SET (96)

APPENDIX D

MODEL 72 HEXIDECIMAL CODED CHARACTER SET (96)

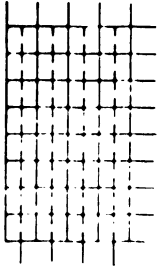

20

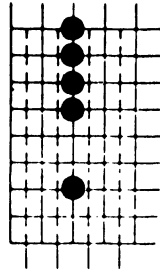

21

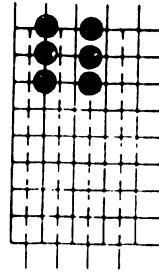

22

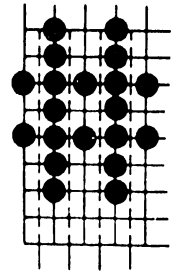

23

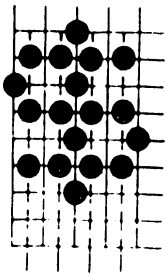

24

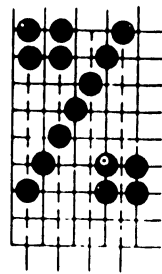

25

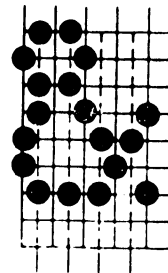

26

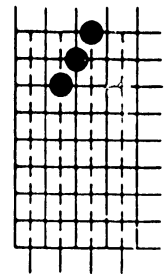

27

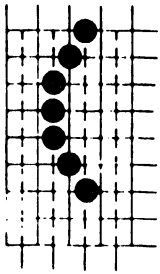

28

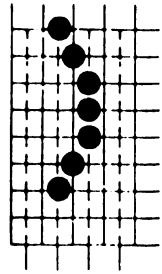

29

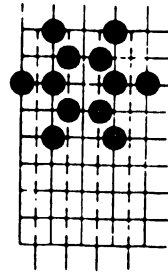

2A

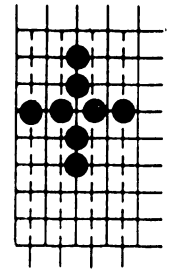

2B

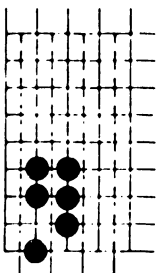

2C

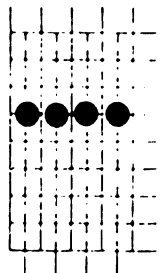

2D

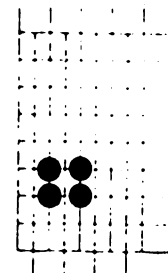

2E

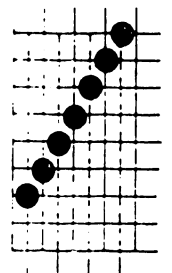

2F

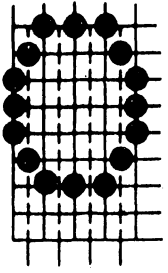

30

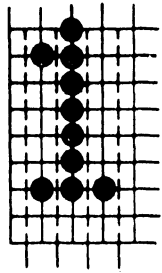

31

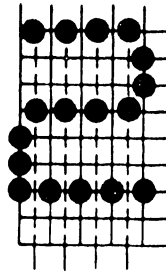

32

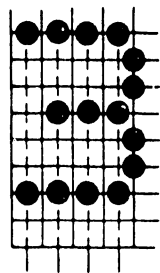

33

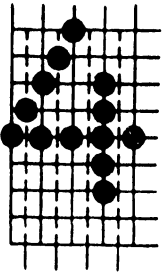

34

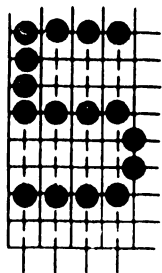

35

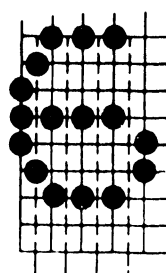

36

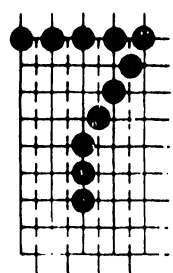

37

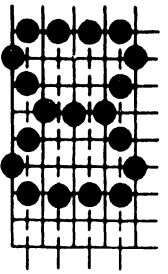

38

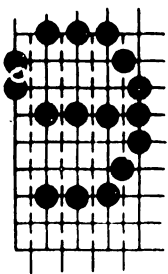

39

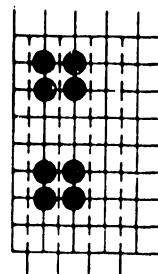

3A

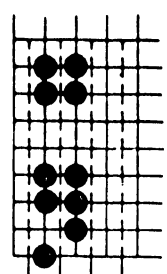

3B

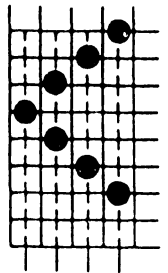

3C

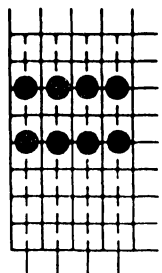

3D

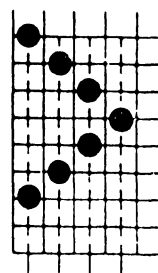

3E

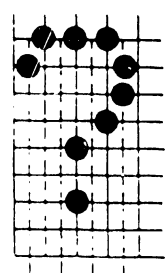

3F



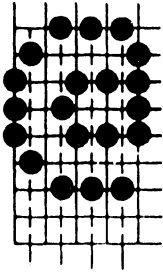

40

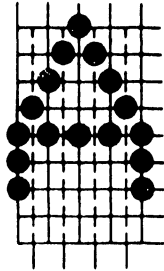

41

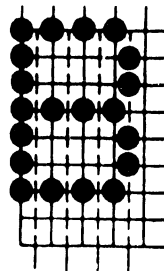

42

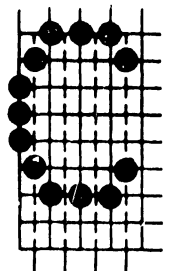

43

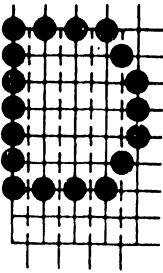

44

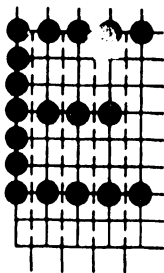

45

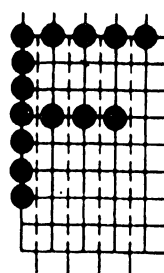

46

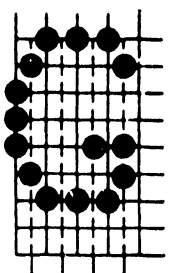

47

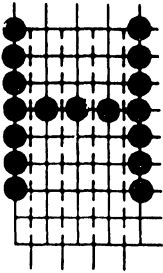

48

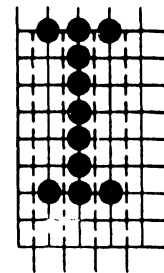

49

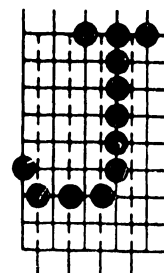

4A

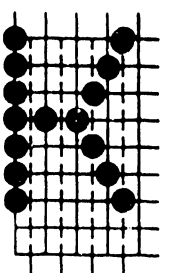

4B

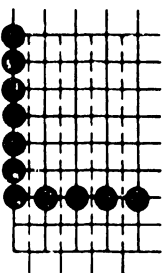

4C

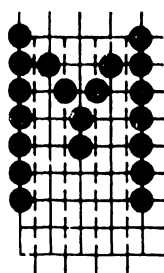

4D

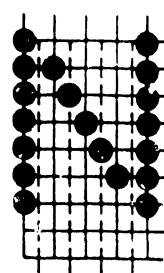

4E

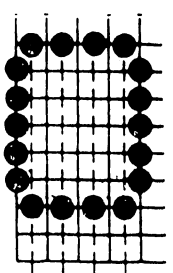

4F

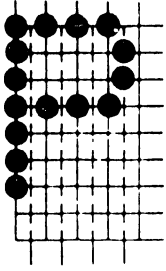

50

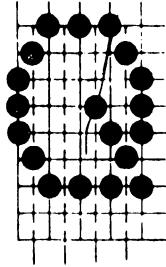

51

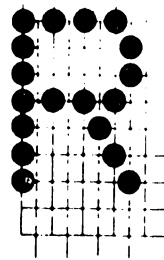

52

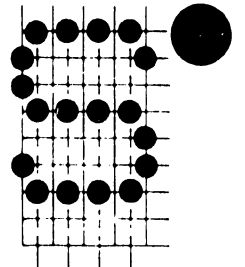

53

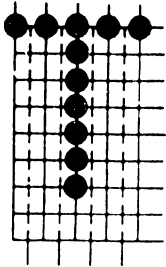

54

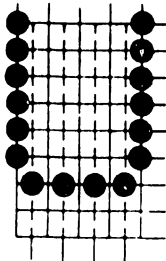

55

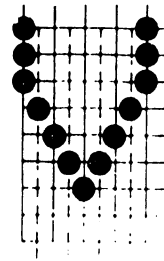

56

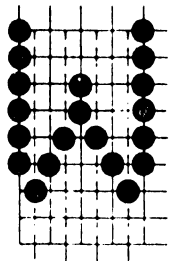

57

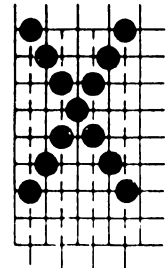

58

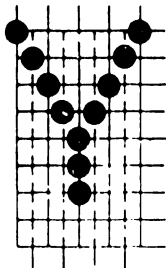

59

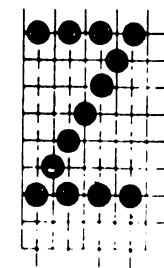

5A

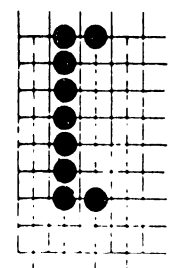

5B

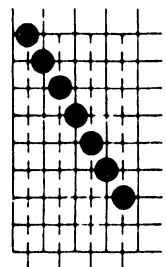

5C

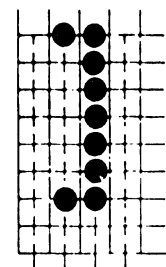

5D

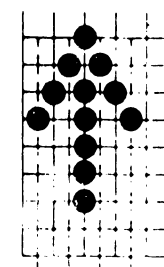

5E

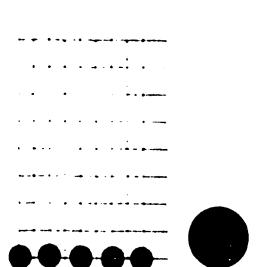

5F

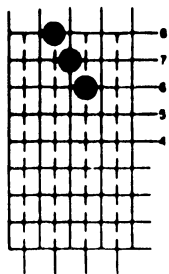

60

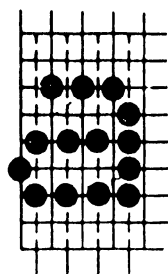

61

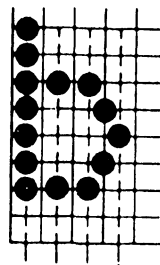

62

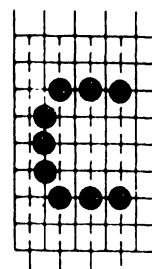

63

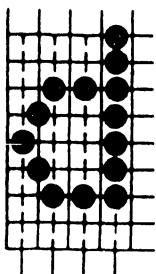

64

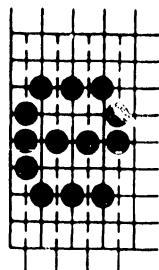

65

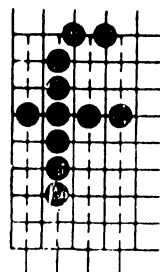

66

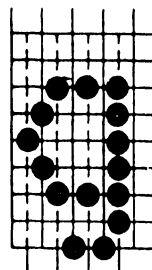

67

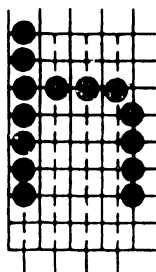

68

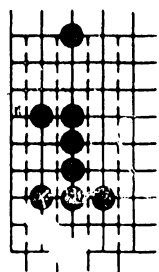

69

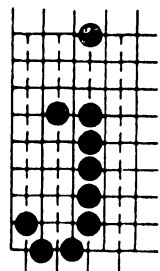

6A

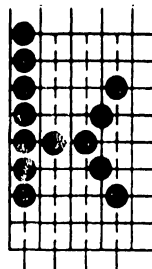

6B

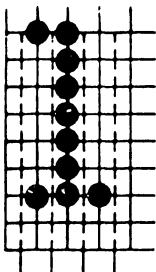

6C

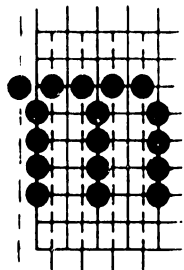

6D

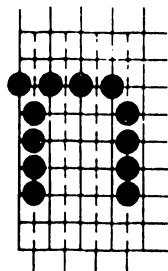

6E

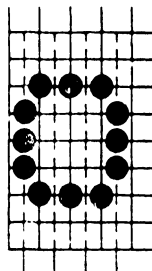

6F



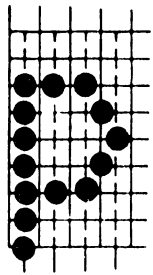

70

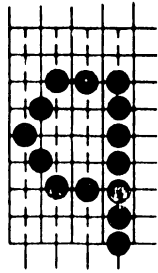

71

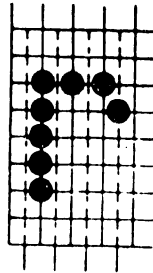

72

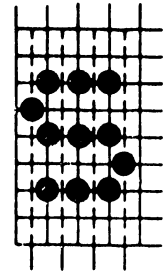

73

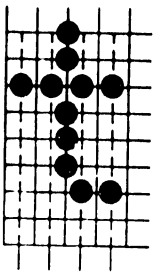

74

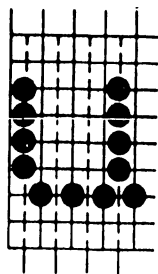

75

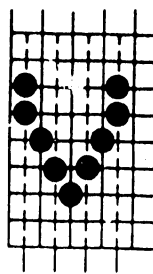

76

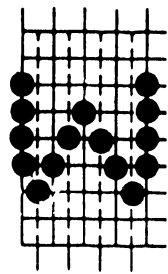

77

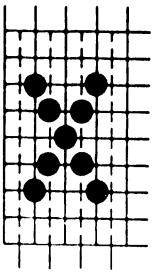

78

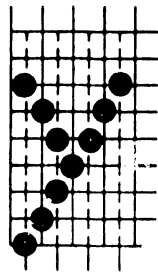

79

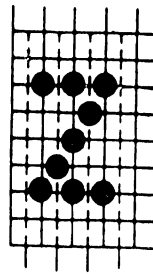

7A

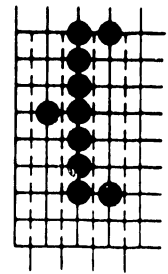

7B

4

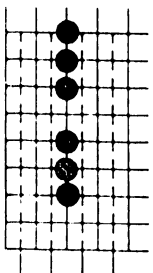

7C

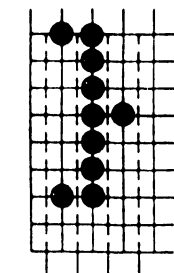

7D

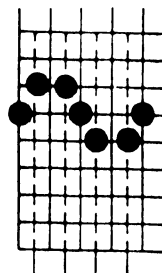

7E

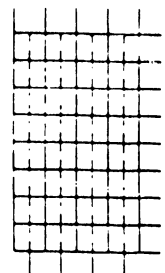

7F



CSN

NO. 81

COMPUTER SYSTEMS NEWSLETTER NO. 81

CATEGORY & SEQUENCE #: 2221V MATRIX PRINTER

#2

PRINTER CONVERSION PROCEDURE

MODEL 2221W TO MODEL 2221V

A. REASON FOR CHANGE

To convert a 2221W Printer to a 2221V Printer, for use on a 2200VS system. The standard 2200 system calls for the printer to do an automatic line feed after each carriage return. The 2200VS does not require this feature.

B. CORRECTION/SOLUTION

Suppress the automatic line feed that occurs after a carriage return.

C. PREREQUISITES

NONE

D. TIME REQUIRED

30 minutes

E. PARTS REQUIRED

NONE

WANG

LABORATORIES, INC.

ONE INDUSTRIAL AVENUE, LOWELL, MASSACHUSETTS 01851, TEL. (617) 851-4111, TWX 710 343-6769, TELEX 94-7421

Printed in U.S.A.
131297

F. PROCEDURE

On the 210-6577 Format and Printing Control board:
(REV 5 and above).

1. Remove the jumper from A to B (to the left of L31) and reinstall that jumper from B to C.
2. Remove the jumper from D to E (between L14 and L15) and reinstall that jumper from E to F.
3. No E-REV update is necessary.
4. Test the printer on-line to ensure that constant double spacing does not occur.

B. On the 210-6577 Format and Printing Control board
(E-REV 4 and below).

1. Cut the etch that connects L31-3 to L31-4.
2. Add a wire from L31-4 to L31-5.
3. Cut the etch that connects L15-1 to L4-11
CAUTION: Cut this etch on the non-component side, at pin 1 of L15).
4. Add a wire from L15-1 to L15-2.
5. No E-REV change is necessary.
6. Test the printer on-line to ensure that constant double spacing does not occur.

SN

NO. 48

Service Newsletter

NO. 48

June 11, 1976

PERIPHERALS #13

The Model 72 Matrix printers were originally designed for top loading of printing paper and later it was decided that front (or bottom) print paper loading was more efficient and reduced the mechanical self-locking effect with the paper guides.

The matrix printers being built now are of the front (bottom) loading type. The effective serial numbers of all WANG matrix printers (front load) Model 72 types are as follows:

<u>MODEL</u>	<u>SERIAL NUMBER</u>
2221W & 2221 LPO	EC2134
621/721W	681007
200W	EW1005

Tom Pickett, of the Central Area, brought certain major differences to our attention recently in the following printer assemblies:

1. Paper Feed, Format and Frame Assembly.
2. Carriage Drive and Tachometer Assembly.
3. Carriage Assembly.

Enclosures 1 and 2 of this Newsletter will inform all service personnel of the new parts used in the front load printers (ENC 1) and status of the old parts (ENC 2). The part numbers and drawing numbers are included to assist in making corrections to the existing 72 Manual. The changes in part numbers will be reflected in the future revision of the Model 72 Matrix Printer Manual. It is recommended that new parts lists and drawings be ordered from the Home Office if printer problems are anticipated.

WANG

LABORATORIES, INC

PRINTED IN USA

836 NORTH STREET TEWKSBURY MASSACHUSETTS 01876 TEL (617) 851 4111, TWX 710 343 6769 TELE X 94 7471

21W FRONT LOADING CHANGES

Enclosure 1

- NEW PARTS -

<u>DESCRIPTION</u>	<u>REPLACES</u>
TACHOMETER BRKT., FRONT LOADING W.L.No. 4514415 DWG. No. C6615-206	TACHOMETER BRKT. W.L.No. 451-4313 DWG. No. B6615-94
BASE CASTING - FRONT LOADING W.L.No. 450-0104 DWG. No. E6615-202	BASE CASTING W.L.No. 450-0096 DWG. No. E6615-10
PAPER GUIDE, INNER W.L.No. 452-4037 DWG. No. C6615-200	PAPER GUIDE, UPPER W.L.No. 452-4025 DWG. No. C6615-60
PAPER GUIDE, OUTER W.L.No. 452-4038 DWG. No. C6615-201	PAPER GUIDE, LOWER W.L.No. 452-4026 DWG. No. C6615-61
PIVOT, OUTER PAPER GUIDE W.L.No. 461-3249 DWG. No. B6615-203	PIVOT, PAPER GUIDE W.L.No. 461-3196 DWG. No. B6615-162
COVER, LOWER REAR W.L.No. 451-2133 DWG. No. C6615-199	NEW
PULLEY, MOTOR W.L.No. 478-0276 DWG. No. B6615-204	PULLEY, 3OLT-187, .375 BORE W.L.No. 478-0276
BELT, 3/16 W, 75 TEETH, 40 D.P. W.L. No. 656-0227	BELT, 65M x 1/8 W 4C D.P. W.L. No. 656-0223
ROLL PIN, .093 x 5/8 W.L. No. 651-1503	ROLL PIN, .093 x 1/2 W.L. No. 651-1509

21W FRONT LOADING CHANGES

Enclosure 2

<u>DESCRIPTION</u>	<u>STATUS</u>	<u>OLD PARTS</u>
TACHOMETER BRKT W.L. No. 451-4313 DWG. No. B6615-94	OBSOLETE NEW PARTS REQUIRED	OBSOLETE
BASE CASTING W.L.No. 450-0096 DWG. No. E6615-10	OBSOLETE NEW PARTS REQUIRED	OBSOLETE
PAPER GUIDE, UPPER/LOWER W.L. No. 452-4025/452-4026 DWG. No. C6615-60/C6615-61	OBSOLETE NEW PARTS REQUIRED	OBSOLETE
PAN, BOTTOM W.L. No. 451-1211 DWG. No. E6634-102	NEW REVISION	CAN BE REWORKED
CARRIAGE GUIDE W.L. No. 452-4016 DWG. No. B6615-30	NEW REVISION	CAN BE REWORKED
ADJ. BLOCK, PAPER GUIDE W.L. No. 461-1540 DWG. No. B6615-215	OBSOLETE	OBSOLETE
PIVOT, PAPER GUIDE W.L. No. 461-3196 DWG. No. B6615-162	OBSOLETE	OBSOLETE
MOTOR BRKT. W.L. No. 451-4302 DWG. No. C6615-95	NEW REVISION	CAN BE REWORKED
PAPER OUT SWITCH W.L. No. 325-2403M DWG. No. B6615-186	NEW REVISION	CAN BE REWORKED
BELT, 65M x 1/8 W 40 DP. W.L. No. 656-0223	OBSOLETE NEW PARTS REQUIRED	OBSOLETE
PULLEY 3OLT-187, .375 BORE W.L. No. 478-0276	OBSOLETE NEW PARTS REQUIRED	CAN BE REWORKED
ROLL PIN, .093 x 1/2 W.L. No.	OBSOLETE NEW PARTS REQUIRED	OBSOLETE

21W FRONT LOADING CHANGES

DESCRIPTION

STATUS

OLD PARTS

BRACKET, PAPER GUIDE
W.L. No. 451-4334
DWG. No. B6615-184

OBSOLETE

OBSOLETE

CARRIAGE CASTING (MACH)
W.L. No. 450-0097
DWG. No. D6615-98

NEW PARTS REQUIRED
NEW REVISION

CAN ONLY BE USED WITH
TOP LOADING PRINTER

SN

NO. 140

Service Newsletter

NO. 140

PERIPHERALS #38

10/31/78

NEW 2221W TIMING FENCE SENSOR PHOTOCELL

A new type of photocell (WL #375-2111) is being installed on newly-manufactured 2221W/V printers only. (A mounting bracket change is required). A sufficient quantity of old style sensor photocells (WL #375-2105) will be kept in stock to provide backup for existing machines. When ordering the old style sensor, be sure to use the 375-2105 number and not the 210-6572 number, since all new 210-6572 assemblies will already have the new photocell installed.

In order to use the new photocell, ECN 8106 must be performed on the 6577 board, bringing that board to E-Rev 8. This ECN makes the 6577 board compatible with both old and new photocells.

NOTES:

- 1) The new photocell (WL #375-2111) has the manufacturers number 'OPB-2501' stamped on it. The old photocell (WL #375-2105) is marked OPB-242.
- 2) The Technical Procedure Manual, which went to print before this ECN was finalized, states that the ECN may only be performed if the new photocell is used. However, since the new board will work with either photocell, it can be used in any 2221W/V printer.

ECN #8106

6577 P.C.

8

1. For use with both photocell types, the Timing Fence circuit is being changed from the configuration shown in Figure 1 to that shown in Figure 2.

WANG

LABORATORIES, INC

ONE INDUSTRIAL AVENUE LOWELL, MASSACHUSETTS 01851 TEL (617) 851 4111 TWX 710 343-6769. TELEX 94 7421

FIGURE 1

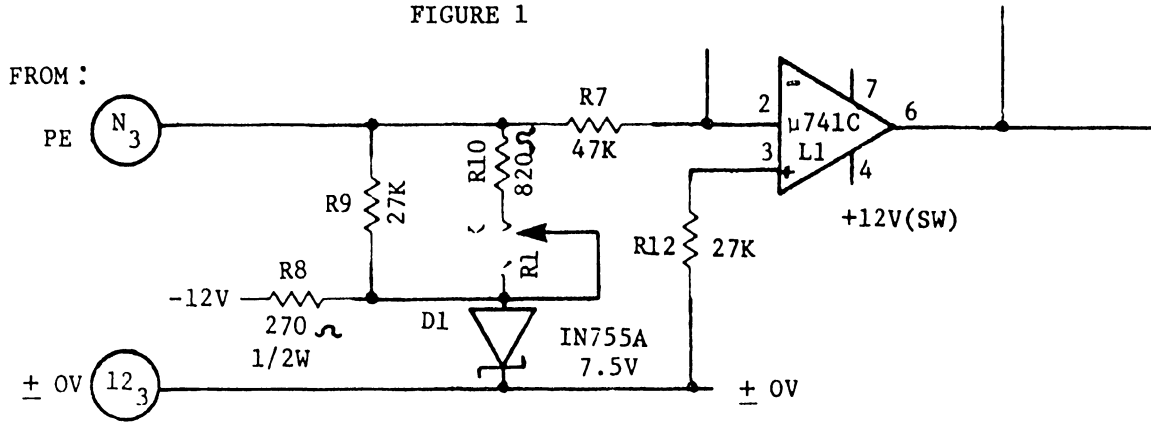

TO :

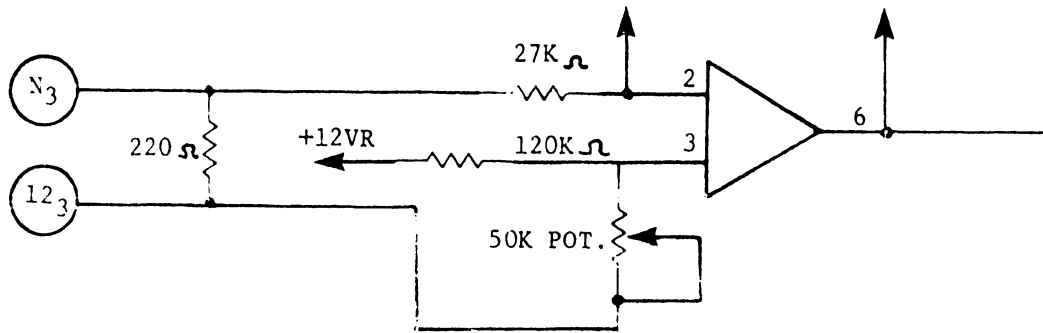

FIGURE 2

SN

NO. 172

Service Newsletter

NO. 172

NOVEMBER 13, 1979

PERIPHERALS #48

Early Model Top Feed Assembly Part Numbers

The Carriage assembly, as well as the Carriage Drive Motor and Tach Assembly used in early Top Feed 2221W printers, are different from the versions of these assemblies used in the current Model 2221W printers.

In the past, it was not possible to order the early versions of the Carriage Assembly or the Carriage Drive Motor and Tach assembly because there were no available Wang part numbers. Now, however, the early versions of the assemblies may be ordered using the following part numbers:

Carriage Assembly, Top Feed, 279-5070-42

Carriage Drive Motor & Tach Assembly, Top Feed, 279-5070-54

NOTICE:

This document is the property of Wang Laboratories, Inc. Information contained herein is considered company proprietary information and its use is restricted solely to the purpose of assisting you in servicing Wang products. Reproduction of all or any part of this document is prohibited without the consent of Wang Laboratories.

WANG

LABORATORIES, INC.

ONE INDUSTRIAL AVENUE, LOWELL, MASSACHUSETTS 01851. TEL. (617) 851-4111. TWX 710 343-8789. TELEX 94 7421

Printed in U.S.A.
13-266

PSN

III C3-1

PRODUCT SERVICE NOTICE

DATE : 03/14/80

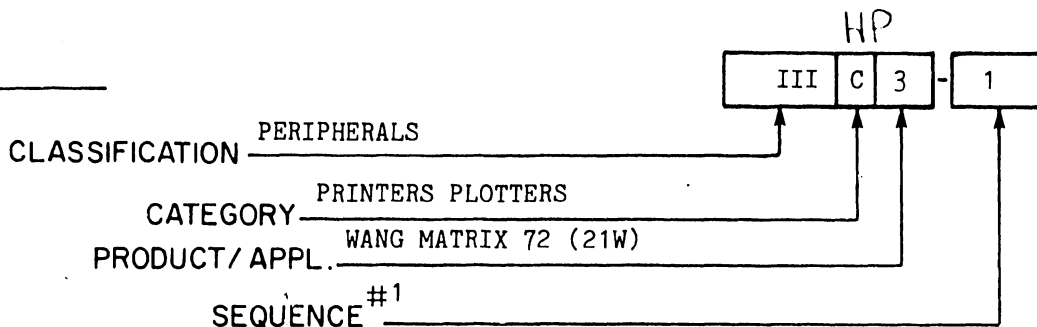

TITLE: 210-6579 Motherboard: ECN's #9647 (E-REV 6) and #13982 (E-REV 7)

210-7076 I/O Control, Data Storage, and Underscore: ECN's #9647 (E-REV 5), #10619 (E-REV 6), and #13984 (E-REV 7)

210-7076-1 I/O Control, Data Storage, and Underscore: ECN's #9647 (E-REV 3) and #10619 (E-REV 4)

210-7076-2 I/O Control, Data Storage, and Underscore: ECN's #9647 (E-REV 2) and #10619 (E-REV 3)

210-7231 2221V Converter Board: ECN 13983 (E-REV 1)

NOTES

This PSN document supersedes CSNL #91, which should be discarded.

Any prior performance of CSNL #91 on 2221W/2221V printers will have accomplished 210-6579 Motherboard modification steps F.2.a through F.2.e and 210-7076 board modification steps F.5.a through F.5.d of this procedure, except as follows:

1. The MKR signal on the 210-6579 Motherboard will not have been jumper-connected between connector pins 9₂ and K₁₃, which is required (refer to step F.2.c).
2. The SFM signal on that same 210-6579 Motherboard will have been jumper-connected between connector pins 10₂ and L₁₃, which is undesirable.

Similarly, performance of a preliminary procedure, distributed as a VS Field Support memorandum to enable field incorporation of ECN #9647, will have produced these same results but will also have removed a necessary open-collector device pull-up resistor, R28 on the 210-7076 board (or its 210-7076-1 or 210-7076-2 counterpart, depending on model of Matrix Printer).



LABORATORIES, INC

ONE INDUSTRIAL AVENUE LOWELL MASSACHUSETTS 01851 TEL (617) 459 5000 TWX 710 343 6769. TELEX 94 7421

Printed in USA
13-5852 12-79

III.C.3-1

This PSN document provides the full modification procedure for all versions (2221V, 2221W, 200W, 5521, and LPO) of the Model 72 Wang Matrix Printer, hereafter called simply the Matrix Printer unless one or more of those different versions must be specified. The document assumes that neither of those preliminary procedures has been performed--but includes notes in the appropriate places to direct the reader to confirm necessary conditions if those preliminary procedures may have been performed and/or to bypass any steps that do not apply to specific models.

A. REASON FOR CHANGE

The unmodified Matrix Printer can cause severe degradation of response time on any parallel workstation tied to the IOP used by the printer (especially when full-buffer lines of more than 132 characters are being processed).

B. CORRECTION/SOLUTION

Modify the handling of carriage return, busy signal, and initiation of the print cycle by the printer electronics.

C. PREREQUISITES

1. The 210-6579 Motherboard must be at E-Rev 5 (ECN's #04765, #04801, #04829, #04860, and #05123 incorporated).
2. The I/O Control, Data Storage, and Underscore board must have ECN's #05227, #05351A, #05535, and #06728 incorporated:
 - a. If a WLI P/N 210-7076 board (2221V or 2221W), must be E-REV 4 or higher (interim modifications will be confirmed or changed).
 - b. If a WLI P/N 210-7076-1 board (200W), must be E-REV 2 or higher (interim modifications will be confirmed or changed).
 - c. If a WLI P/N 210-7076-2 board (5521 or LPO), must be E-REV 1 or higher (interim modifications will be confirmed or changed).

D. TIME REQUIRED

Two hours, maximum.

E. PARTS REQUIRED

NOTE

Except for approximately half of the designated length of P/N 600-3004 insulated jumper wire, all required parts listed in the following table pertain only to modifications needed for 2221V Printers. If the unit under repair is a 2221W, 200W, 5521, or LPO Printer, therefore, the listed parts are not required.

<u>CATALOG NO.</u>	<u>NOMENCLATURE</u>	<u>QUANTITY/EXPLANATION</u>
210-7231	2221V Converter Board (E-REV "0" presumed)	One (2221V Printer, only). (Initial E-REV "0" version <u>may</u> have been installed by preliminary incorporation of ECN #9647)
300-1906	Capacitor, 0.001 microfarad	One (2221V Printer, only).
330-3047	Resistor, 4.7 kilohms	One (2221V Printer, only).
330-4010	Resistor, 10 kilohms	One (2221V Printer, only).
376-0104	IC, dual one-shot (Type 9602)	One (2221V Printer, only).
600-3004	Wire, solid, 26-gauge, plastic-coated	Six feet, max.

F. PROCEDURE

1. Gain access to the underside of the #210-6579 Motherboard on the Matrix Printer's #270-0260 Chassis Assembly for wiring changes, as follows:
 - a. Facing the printer from the front, remove the left side cover by sliding it left until the holding rods become clear.
 - b. Remove the right side cover by sliding it right until the holding rods become clear. Be careful not to damage the attached wiring, which must be removed as follows:
 - (1) Disconnect the signal harness from the bottom of the control panel.

- (2) Pull both AC-power leads from the ON/OFF power switch, and then remove the associated Motherboard power lines from the cable clamps.
- c. Remove the rear cover by lifting it away from the unit, disconnecting the ground wire attached to that cover by loosening the attaching phillips-head screw on the rear of the #210-6579 Motherboard heat-sink assembly.

NOTE

This procedure presumes that the original #210-6576 and #210-6728 printed circuit boards have been previously replaced by #210-7076/-7076-1/-7076-2 and #210-7028 boards, respectively. If not, make that replacement at this time.

- d. Remove the following printed-circuit cards from the Motherboard assembly:
- (1) #210-7076 (or its -1 or -2 counterpart) I/O Control, Data Storage, and Underscore card (from "6576" connectors).
 - (2) #210-6577 Format and Printing Control card (from "6577" connectors).
 - (3) #210-7028 EA Memory & Regulators and Underscore card (from "6728" connectors).
 - (4) #210-7231 2221V Converter Board (from Motherboard connectors J12 and J13), if applicable (this card will have been installed only if the printer under repair is a Model 2221V and a preliminary incorporation of ECN #9647 has been made).
- e. Remove the signal-harness connector plugs from Motherboard connectors J2, J3, J4, J5, J6, and J8 (leaving the connector plugs in place at Motherboard connectors J1, J9, J10, and J11).
- f. Remove the I/O interface finger-board connector from Motherboard connector J12.

- g. To obtain fan assembly clearance space, remove the format tape guide from the format control assembly on the left side of the unit by removing two phillips-head fastening screws (see Figure 1).
 - h. To obtain clearance for extraction of the #270-0260 Chassis Assembly, release the #451-4359 lefthand support bracket from the #279-5070-35 lefthand side subassembly frame by removing two phillips-head screws (see Figure 1).
 - i. To obtain chassis assembly freedom, release the #270-0262 resistor bracket assembly from the #279-5070-34 format paper feed frame assembly by removing two phillips-head screws and washers (see Figure 2).
 - j. Release the #270-0260 Chassis Assembly by removing the four tie-down bolts that fasten the Chassis Assembly to the frame.
 - k. Slide the #270-0260 Chassis Assembly to the rear and then lift it away from the Printer frame to remove that assembly away from the unit. Stand the assembly on its back edge to gain access to the connector terminals on the underside (i.e., noncomponent side) of the #210-6579 Motherboard.
2. Using 26-gauge solid wire (WLI #600-3004 or equivalent), add three jumpers to the noncomponent side of the #210-6579 Motherboard, as follows (see Figure 3):

NOTE

If an earlier effort to correct slowdown of parallel workstations was attempted by performance either of a preliminary VS Field Support memorandum for ECN #9647 or of CSNL #91A, an unwanted SFM jumper connection will have been added to the #210-6579 Motherboard from pin 9₂ to pin L₁₃, and both of substeps a and b, following, will have been completed. If so, remove that jumper connection from the board (and from documentation records) and then proceed directly to substep c.

- a. Connect the \overline{CRd} output from pin L of "6576" (i.e., the 7076-type I/O Control card location) connector 1 (10th pin from the left end of the bottom row, because no G or I pins exist) to pin D of connector J12 (4th pin from the left end of the bottom row).

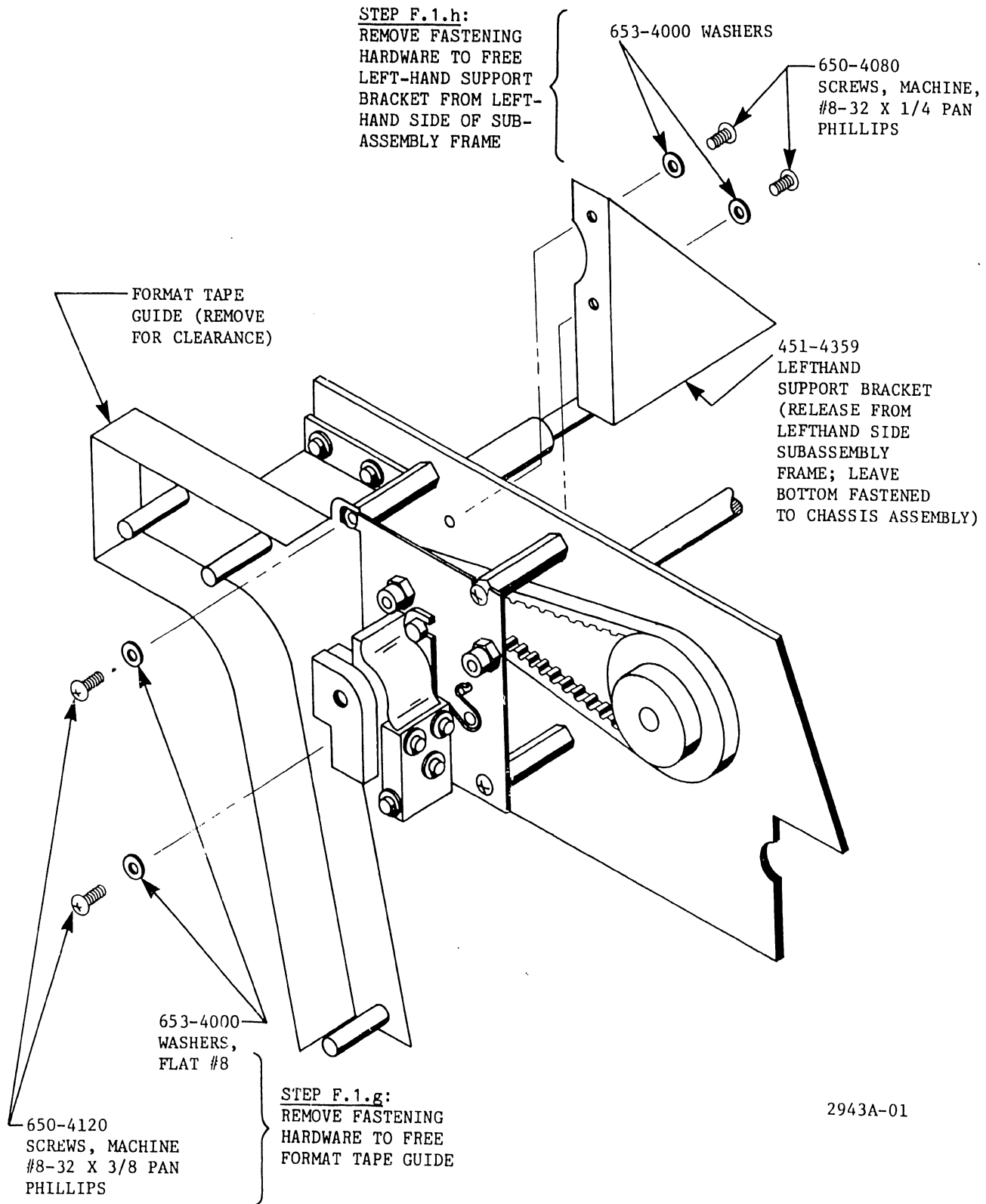
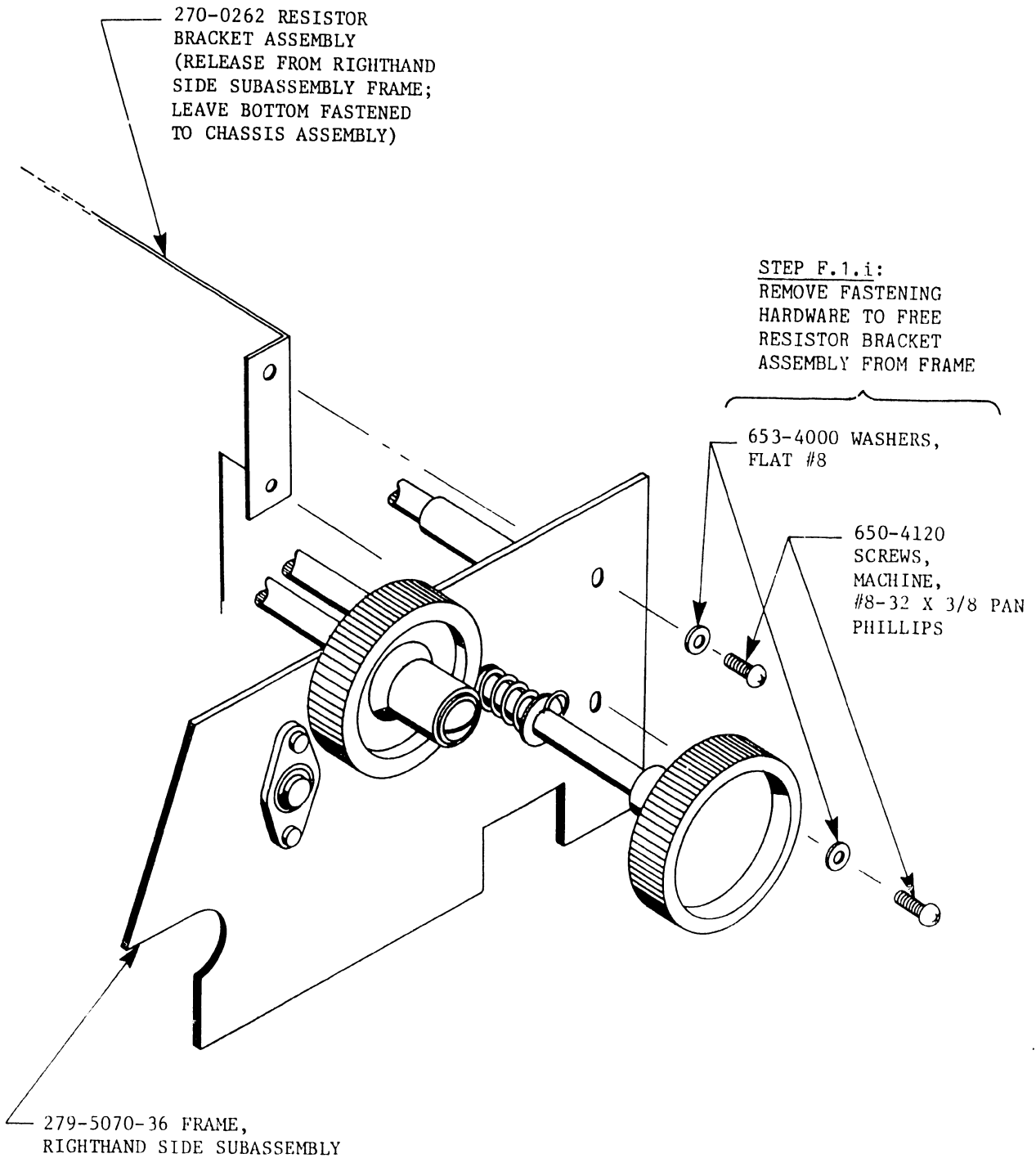

Figure 1. Obtaining Left-side Clearance for
Removal of #270-0260 Chassis Assembly.



2943-02

Figure 2. Obtaining Right-side Clearance for
Removal of #270-0260 Chassis Assembly

STEP 2.a:
ADD JUMPER
FROM "6576"
(7076) PIN L₁
TO PIN J12-D

STEP 2.b:
ADD JUMPER
FROM "6576"
(7076) PIN B₂
TO PIN J13-B

STEP 2.c:
ADD JUMPER
FROM "6576"
(7076) PIN 9₂
TO PIN J13-K

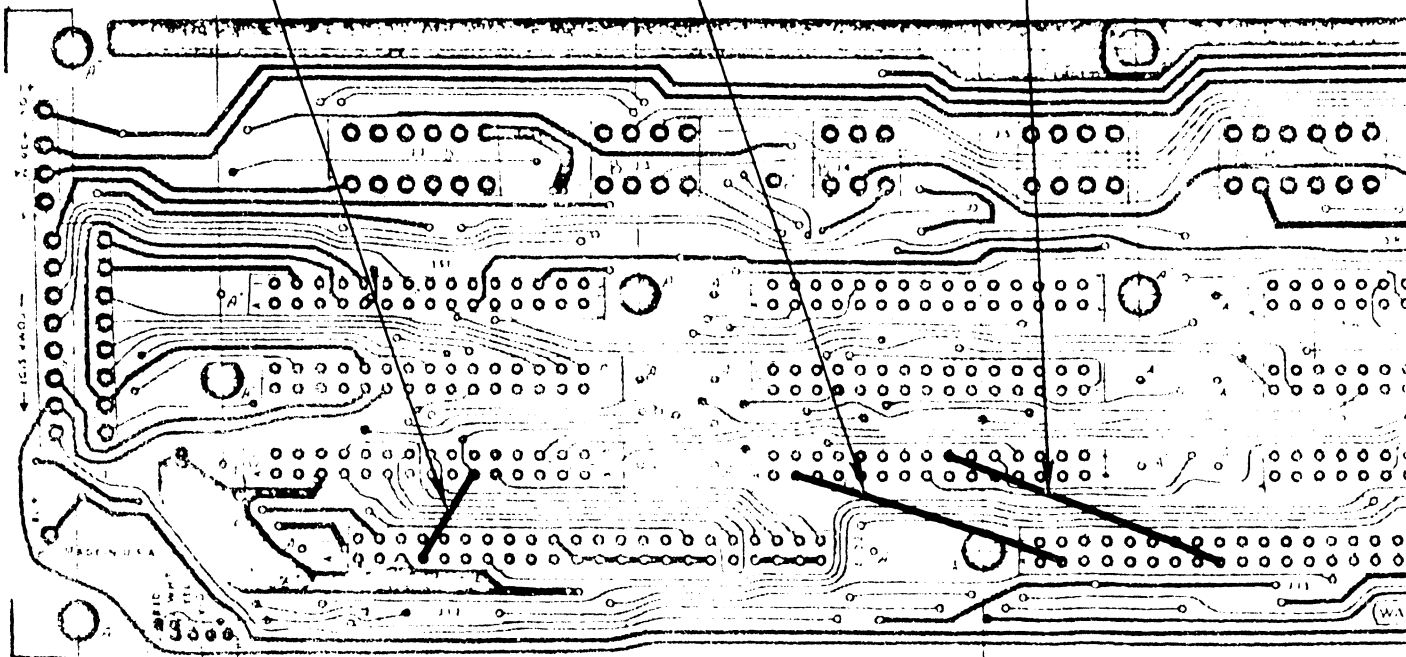

LEFT-HAND END, COMPONENT SIDE

0455t-03

Figure 3. Jumper Connections to be Added to #210-6579
Motherboard's Noncomponent Side

- b. Connect the $\overline{\text{CLR}}$ output from pin B of "6576" connector 2 (2nd pin from the left end of the bottom row) to pin B of connector J13 (2nd pin from the left end of the bottom row).
 - c. $\overline{\text{MKR}}$ output from pin 9 of "6576" connector 2 (9th pin from the left end of the top row) to pin K of connector J13 (9th pin from the left end of the bottom row).
 - d. Increment the E-REV level sticker number to a value of 7 (ECN #13982 incorporated).
 - e. Add the just-installed connections to the Signal Run List, Sheet 1, on page 7-22 of the system documentation copy of the Model 72 Matrix Printer Maintenance Manual (03-0027-0), as follows:
 - (1) Add "D" to J12 column as the $\overline{\text{CRd}}$ entry.
 - (2) Add "B" to J13 column as the $\overline{\text{CLR}}$ entry.
 - (3) Add " $\overline{\text{MKR}}$ " as a new row, with a 9_2 entry in the "6576" (i.e., 7076) column and a $\underline{\text{K}}$ entry in the J13 column.
3. Slide the modified #270-0260 Chassis Assembly back into its normal position on the Matrix Printer's frame, and secure that assembly in place by replacing all fastening hardware previously removed during performance of steps F.1.g through F.1.j.
 4. Replace the Matrix Printer signal harness connector plugs to Mother-board connectors J2, J3, J4, J5, J6, and J8, and then install the unmodified 210-7028 card in the "6728" slot of that assembly and install the unmodified #210-6577 card in its "6577" slot.
 5. Modify the #210-7076 I/O Control, Data Storage, and Underscore circuit card assembly (or its #210-7076-1 counterpart if a 200W Printer, its #210-7076-2 counterpart if a 5521 or LPO Printer) as follows, using 26-gauge solid wire (WLI #600-3004 or the equivalent) for the required jumpers (see Figures 4 & 5):

STEP 5.a:
OPEN ETCH-PATH
FROM PIN L29-11
TO PIN L3-1

STEP 5.g:
CONNECT PIN L15-8 TO
PIN 9 OF CONNECTOR 2

UPPER LEFT-HAND CORNER
(NONCOMPONENT SIDE)

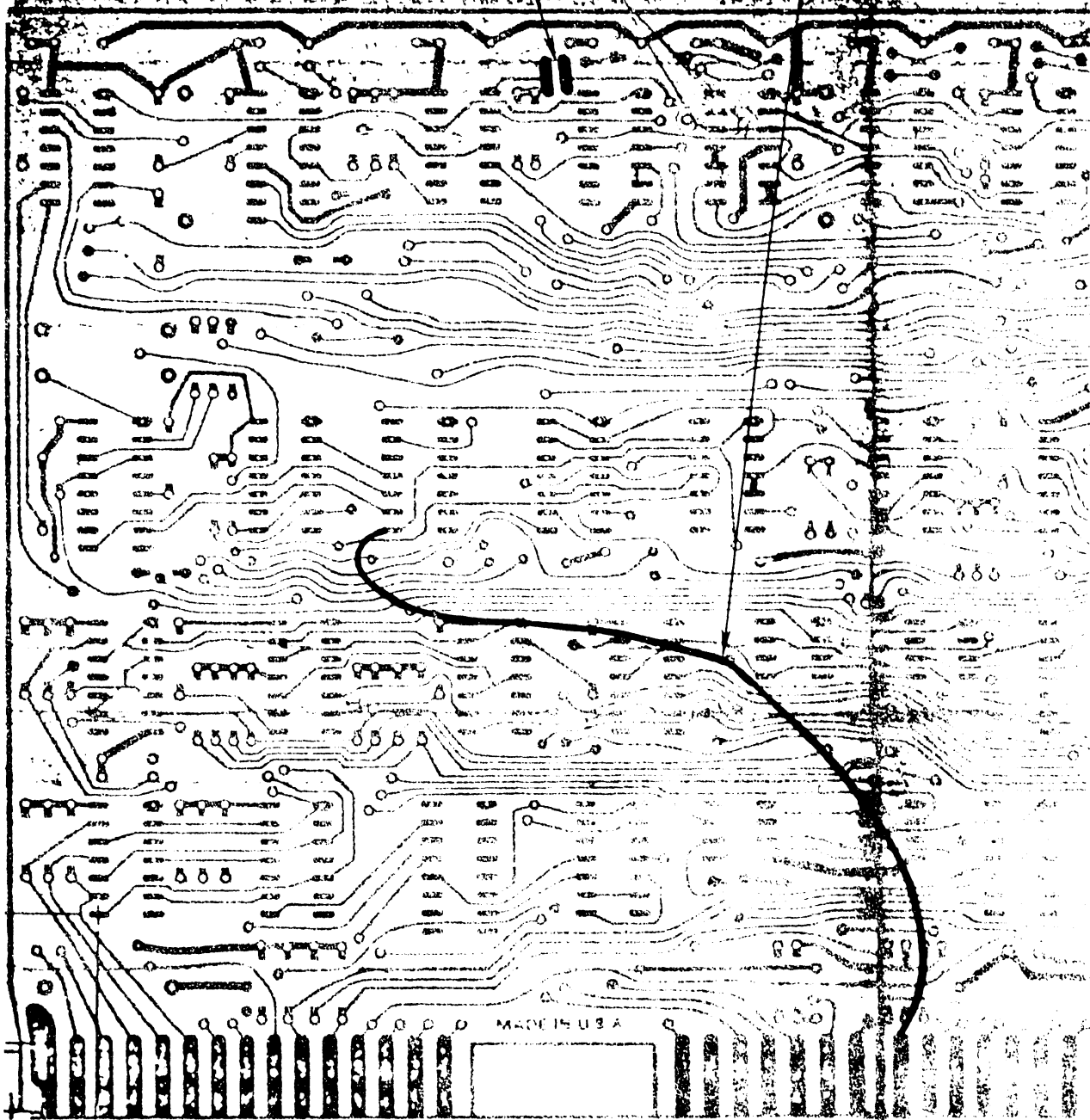

CONNECTOR 2

0445t-04

Figure 4. Modifications to be Made on Drill Side of #210-7076
I/O Control, Data Storage, and Underscore Board.

STEP 5.c:
ADD JUMPER
FROM PIN L9-8
TO PIN L31-13

STEP 5.d:
ADD JUMPER
FROM PIN L39-8
TO PIN L3-1

STEP 5.f:
ADD L14-CHIP NAND
GATE, AS FOLLOWS:

- (1) CONNECT PIN L14-4
TO PIN L5-12
- (2) CONNECT PIN L14-5
TO PIN L41-8
- (3) CONNECT PIN L14-6
TO OPENED PIN
L39-9

STEP 5.e:
REMOVE JUMPER-WIRE
CONNECTION BETWEEN
PIN L39-9 AND GROUND
(PIN L39-7)

STEP 5.b:
OPEN JUMPER "A"
(LOCATED JUST TO
THE RIGHT OF Q3)

LOCATION FOR R28
(4.7K, 1/4W, 10%),
TO BE REPLACED IF
PREVIOUSLY REMOVED

0445t-05

Figure 5. Modifications to be Made on Component Side of #2110-7076
I/O Control, Data Storage, and Underscore Board.

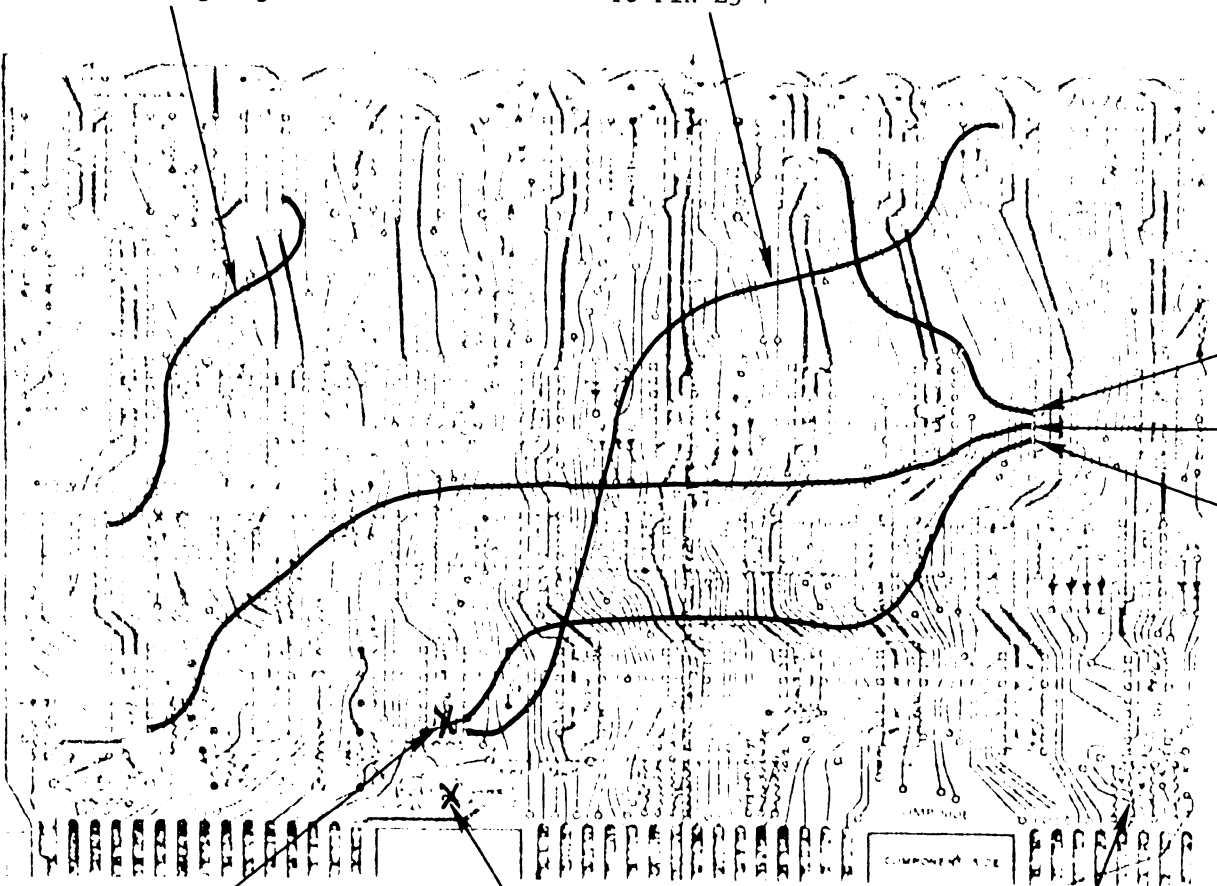

NOTE

If an earlier effort to correct slowdown of parallel workstations was attempted by performance of CSNL #91A, substeps a through d, following, will have already been accomplished. If such correction was attempted by performance of a preliminary VS Field Support memorandum for ECN #9647, those same substeps will have been accomplished but a necessary open-collector device pull-up resistor, R28 on the 210-7076 board, will have been removed. In either case:

- (1) Confirm that a 4.7-kilohm, 1/4W, 10% resistor (WLI P/N #330-3047-4B or the equivalent) is connected between pin L39-8 (open-collector inverter output) and the +5VR bus on the 210-7076 board.
- (2) Confirm that the system schematic for the 7076-type card (whatever version) includes that component as pull-up resistor R28, connected between +5V and pin L39-8, which should be designated as the output of an open collector 7406 inverter (not a 7404 inverter, as originally designated).
- (3) Then proceed directly to substep e, following, bypassing substeps a through d.
 - a. On the noncomponent side of the card, cut (open) the etch-path connection from pin L29-11 to pin L3-1 (see Figure 4).
 - b. On the component side of the card, cut or remove jumper "A" (located directly to the right of Q3), opening the SLCTR input at pin 1 of connector 3 (see Figure 5).
 - c. Add a jumper connection from pin L9-8 to pin L31-13 as a substitute for the discarded SLCTR input.
 - d. Add a jumper connection from pin L39-8 to pin L3-1 as a substitute for the discarded L29-11 gate output.

NOTE

If the card being modified is a #210-7076-1 card (for 200W Printer) or a #210-7076-2 card (for 5521 or LPO Printer), bypass substeps e through g, following (which pertain only to serial operation), and proceed directly to substep h.

- e. Remove the jumper-wire connection between pin L39-9 and ground (pin L39-7).
 - f. Incorporate a hitherto-unused NAND gate from the L14 SN7400 chip to the circuit as follows to enable the SLCT output and the L3-6 NAND gate output when pin L5-12 (FF Q) and pin L41-8 are both high (i.e., when the printer is selected and no paper-out condition has been detected):
 - (1) Connect a jumper between gate input pin L14-4 and SL signal source at pin L5-12.
 - (2) Connect a jumper between gate input pin L14-5 and PO complementary output pin L41-8.
 - (3) Connect a jumper between just-opened pin L39-9 and gate output pin L14-6.
 - g. On the noncomponent side, add a jumper wire between the MKA signal at pin L15-8 and pin 9 of connector 2 (see Figure 4).
 - h. Update the E-REV level sticker on the noncomponent side of the card as follows:
 - (1) If a #210-7076 card (2221V or 2221W Printer), raise sticker to a value of 7 (ECN's 9647, 10619, and 13984 incorporated).
 - (2) If a #210-7076-1 card (200W Printer), raise sticker to a value of 4 (ECN's 9647 and 10619 incorporated).
 - (3) If a #210-7076-2 card (5521 or LPO Printer), raise sticker to a value of 3 (ECN's 9647 and 10619 incorporated).
 - i. Add the just-installed changes to the system documentation copy of the 7076-board schematic.
6. Install the just-modified #210-7076 circuit card (or its #210-7076-1 or #210-7076-2 counterpart, as applicable) in the "6576" slot of the Motherboard assembly.

NOTE

Perform steps 7 and 8, following, only if printer under repair is a 2221V Printer. For all other models (2221W, 200W, 5521, or LPO), proceed directly to step 9, bypassing these steps.

7. Modify the #210-7231 Converter Board circuit card assembly as follows (see Figure 6), using 26-gauge solid wire (WLI #600-3004 or the equivalent) for the required jumpers:
 - a. Cut an opening in the component-side etch path between pin L9-1 and pin L of connector 2.
 - b. Install a 9602 one-shot IC (WLI P/N #376-0104) in "spare" location L7, incorporating the following jumpers:
 - (1) A circuit-ground connection between pin L7-8 and the $\pm 0V$ ground etch path passing vertically through the left-hand side of location L7.
 - (2) A V_{cc} connection between pin L7-16 and the +5V etch path passing vertically through the right-hand side of location L7.
 - (3) A trigger-input connection between pin L7-5 and pin K of connector 2.
 - (4) A trigger-input bias connection between pin L7-4 and the $\pm 0V$ ground-circuit etch path passing vertically through the left-hand side of location L7.
 - (5) A complementary-output connection from pin L7-7 to pin L9-1.
 - c. Install new components C10 and R10 as a 3.41-microsecond (approx.) pulse-timing circuit for the new L7 one-shot as follows, mounting these components in the unused L6 location:
 - (1) Connect an 0.001- μF capacitor (WLI P/N #300-1906) between pin L7-1 and pin L7-2.

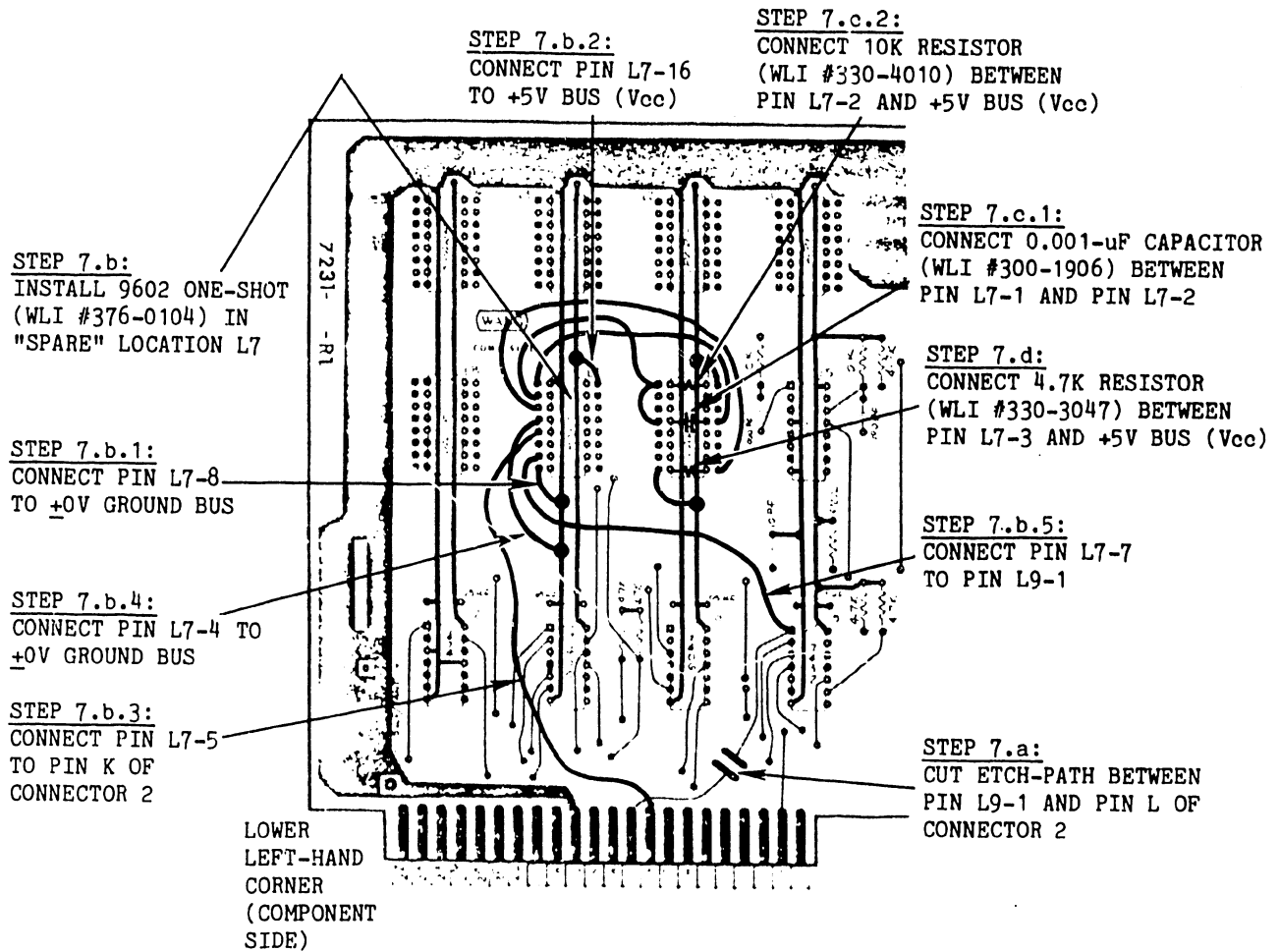

0445t-06

Figure 6. Modifications to be Made on #210-7231
2231 Converter Board.

III.C.3-1

- (2) Connect a 10-kilohm resistor (WLI P/N #330-4010) between the capacitor connection to pin L7-2 and the +5V etch path passing vertically through the right-hand side of location L6.
- d. Install a 4.7-kilohm resistor (R9, WLI P/N #330-3047) as a CLEAR input pullup path in that same vacant L6 location, connecting that resistor between pin L7-3 and the +5V etch path passing vertically through the right-hand side of location L6.
- e. Install an E-REV level 1 sticker (ECN #13983 incorporated) on the circuit side of the #210-7231 Converter board.
- f. Add the just-installed changes to the system documentation copy of the 7231-board schematic.
8. Install the just-modified, dual-connector #210-7231 Converter circuit card in Motherboard connectors J12 and J13, with the component side facing to the rear of the Printer.
9. If the printer under repair is a Model 2221V Parallel Printer, install the fingerboard connector (originally removed from Motherboard connector J12) in connector 3 on the just-installed #210-7231 2221V Converter circuit card. For all other models, simply reinstall the fingerboard connector in Motherboard connector J12.
10. Reconnect the rear-cover grounding wire, and then replace the rear cover in its normal position.
11. Reconnect the control panel AC-power and signal connectors, and then replace both side covers.
12. Test the modified Matrix Printer for on-line compatibility, including a checkout of response time for all workstations connected to the same IOP.

PSN

III C3-2

PRODUCT SERVICE NOTICE

DATE : 1/27/81

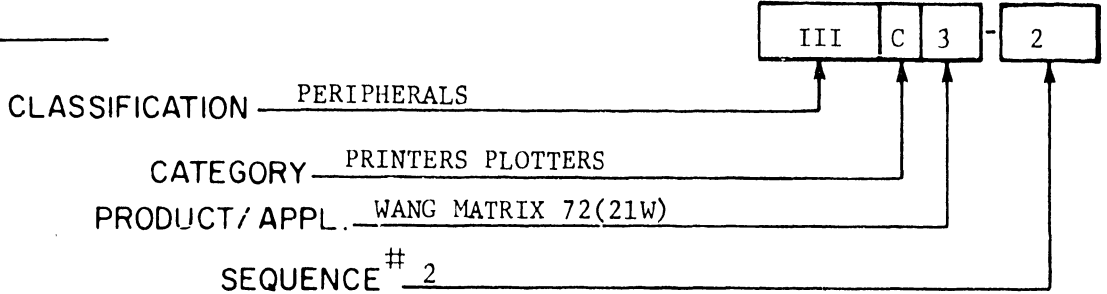

TITLE:

SERIAL/PARALLEL INTERFACE FOR PRINTER OPTIONS

This PSN applies to Wang Model 5521 Matrix Printers.

1. GENERAL INFORMATION

All printers used on Wang systems are parallel interface machines. On the 928 Systems, OIS (130, 140), and VS (with serial IOP) the data is sent out in a serial format. Therefore, a device is needed to convert the serial data from the CPU into the parallel data required by the printer. This conversion is accomplished by a serial-to-parallel translator - an 8080 controlled device that converts serial data to parallel data and vice versa.

Certain modifications are required in each printer to convert it from a parallel to a serial interface. These modifications are discussed in this PSN.

The serial interface printer requires microcode to perform such functions as top of form, line feed, select, print, etc. The printer will not operate unless this microcode has been loaded into the memory in the translator. Also, the printer keyboard no longer controls the printer directly when a translator is used. The printer keyboard inputs to the translator which, in turn, controls the printer. In 928 systems and OIS the microcode is loaded into the translator memory when the printer is powered up. In VS Systems with serial IOP the microcode is not loaded until a document is queued to the printer.

Different printer models need different microcode to operate. This is provided for by switch settings on the 210-7348 CPU board. Also, the 210-7446 I/O board has switches which must be properly set and some jumper connections which must be made. The switch settings and jumper connections required for the 5521 printer are given in this PSN.

2. REFERENCES

All communication between the master CPU and the printer is controlled by semaphores. These semaphores are instructions and data that are sent between the master CPU and the printer CPU.

Communication between the VS systems with serial IOP and the printer is essentially the same as in 928 systems. A detailed Theory of Operation of serial/parallel translators is given in the WP 10/20/30 Maintenance Manual, Vol. III (Part No. 729-0652). Further information on the interface translator assemblies may be found in Word Processing Newsletter No. 30/30A (Part No. 729-0541-1).

3. PC BOARD DESCRIPTIONS

A brief description of the CPU, I/O and memory PC boards used in the translator assembly follows.

210-7348 CPU Board

This board contains the 8080 CPU with its associated data and address busses. The board also contains the system timing circuits, status decoder, data and address buffers, refresh timing and parity generators and checkers, part of the data link circuit including line drivers and receivers, data detection circuits and serial/parallel register.

210-7446 I/O Board

This board contains portions of the data link logic including the instruction register, byte timing register and DMA timing circuits. It also has the IN and OUT command decoders, printer control circuits, external status gate and data out registers.

210-7747 and 210-7547 (16K and 32K Memory Boards)

These boards contain printer memory and memory control circuits. Included are bank select, address counter, refresh counter, address mux, data in and out buffers and PROM memory with associated buffers.

4. PRINTER MODIFICATIONS

The 5521 serial printer uses a serial/parallel translator assembly #270-0391 to convert serial input data to parallel format.

Serial data is received in the translator via TNC/BNC coax and the parallel data is sent from the translator to the printer via interface cable #220-0165. The translator assembly is plugged into the AC receptacle underneath the printer. It is powered up in proper sequence when power is applied to the printer.

A list of differences between the serial and parallel versions of the 21W printer follows.

<u>PARALLEL</u>	<u>PCBs</u>	<u>SERIAL</u>
210-7028		210-6727D
210-7076		210-7076-2
210-6577		210-6577
(Jumper A-B and D-E)		(Jumper B-C and E-F)

ASSEMBLIES

271-1109 (keyboard)	271-1129 (keyboard)
279-5070-19 (carriage assy)	279-5070-46 (carriage assy)

ALSO

Additional printhead cooling fan (279-0304) in serial printer.

5. TRANSLATOR CIRCUIT ADJUSTMENTS

The switch banks (SW1) on the 210-7348 CPU board and the 210-7446 I/O board must be set as follows:

<u>SW1</u>	<u>SW1</u>
!O! !O!	!O! !O!
!F! !N!	!F! !N!
!F! ! !	!F! ! !
!X! 1 ! !	!X! 1 ! !
!X! 2 ! !	!X! 2 ! !
! ! 3 !X!	!X! 3 ! !
! ! 4 !X!	!X! 4 ! !
! ! 5 !X!	!X! 5 ! !
210-7348	210-7446

Jumpers must be installed on the 210-7446 board as follows:

HI - out
DE - in
AC - in
AB - out
GF - out
HJ - in (L42-3 to L32-14)

Figure 1 shows the location of SW1 on 210-7348. Figure 2 shows locations of SW1 and the six jumpers on 210-7446.

6. TROUBLESHOOTING

When a printer fails to operate the problem could lie in the master CPU or controller, in the cables connecting the serial/parallel translator to the CPU or to the printer, in the translator itself, or in the printer itself. A failure of the printer to IPL generally indicates that no code is being loaded into it. This condition could be caused by a problem in the master controller, in the translator or in the cabling between the two.

If the printer will IPL, a fault in the printer hardware is indicated. However, if the problem appears to be in the translator, there is no easy way to troubleshoot this unit in the field except by substituting suspected bad modules with known good ones. All cabling and internal voltages should be checked before board replacement is tried. The switches and jumpers on a replacement board should be checked for correct configuration before this board is inserted.

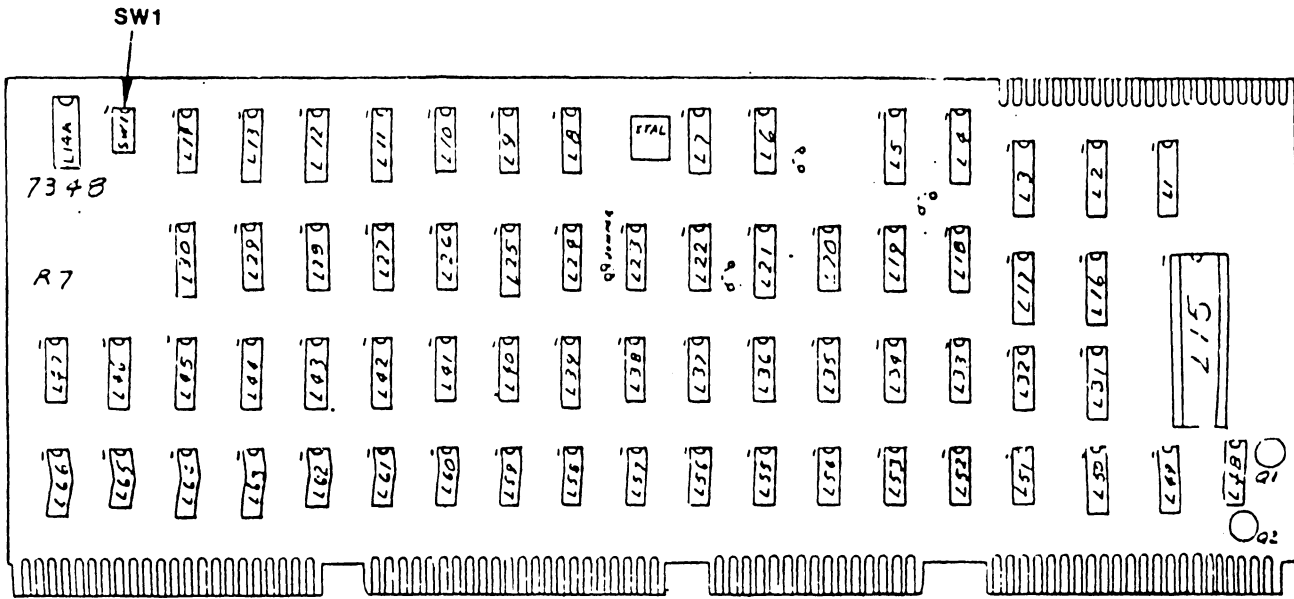

FIGURE 1 PCB 210-7348 ASSEMBLY

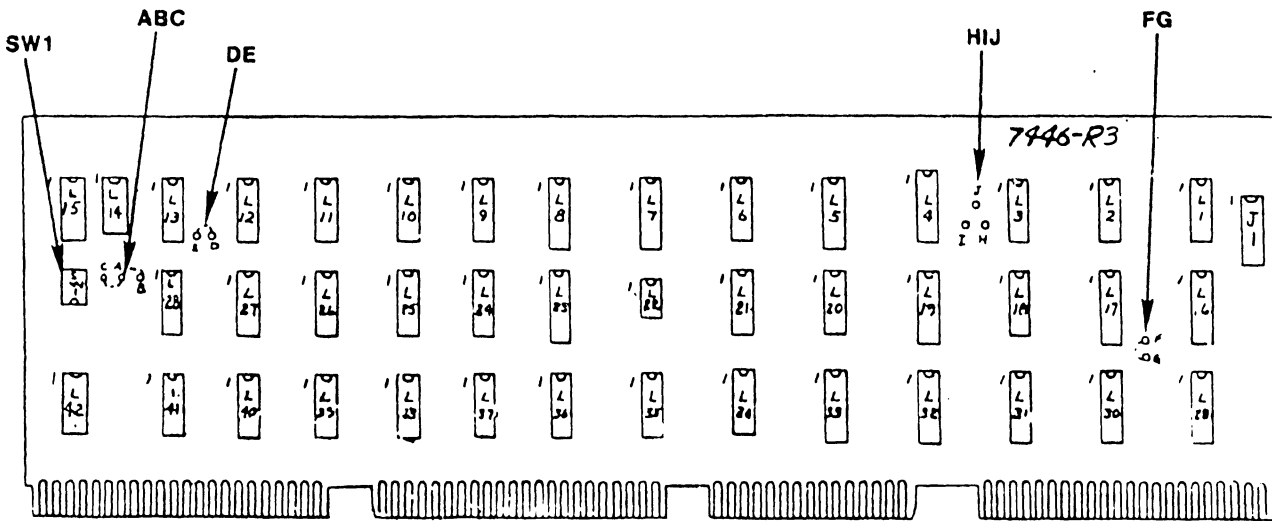

FIGURE 2 PCB 210-7446 ASSEMBLY

SECTION

7

ELECTRI-

CAL

SCHE-

MATICS

SECTION 7
ELECTRICAL SCHEMATICS

7.1 INTRODUCTION

Section 7 consists of a signal run list to assist the technician in tracing signals that are wired to one or more electrical boards. Included are the schematics of electrical boards used in the printer listed in numerical order. Circuit boards 6576 and 6728 are replaceable with 7076 and 7028 boards which are included in the listing shown below.

7.2 LIST OF ELECTRICAL SCHEMATICS

<u>DESCRIPTION</u>	<u>DRAWING NUMBER</u>
MAIN HARNESS	6482-47
CAP. HARNESS	6482-48
I/O INTERFACE CABLE	6482-49
HEAT SINK HARNESS	6482-50
REED SWITCH HARNESS	6482-51
LOGIBLOC RESISTOR BRACKET	6568
FINGER BOARD #2	6573
PHOTOTRANSISTOR	6574
LED (LAMP) MTG.	6575
I/O CONTROL AND DATA STORAGE	6576
FORMAT AND PRINTING CONTROL	6577
MOTHERBOARD	6579
HEAT SINK ASSY.	6635-998
POWER CIRCUIT	6635-999
DIODE BOARD	6704
EA MEMORY AND REGULATOR	6728
LOGIBLOC (SWITCH & LAMP)	6734
LOGIBLOC MATRIX INTERFACE	6751
EA MEMORY & REGULATOR AND UNDERSCORE	7028
I/O CONTROL DATA STORAGE AND UNDERSCORE	7076

7.3 SIGNAL RUN LIST (3 SHTS)

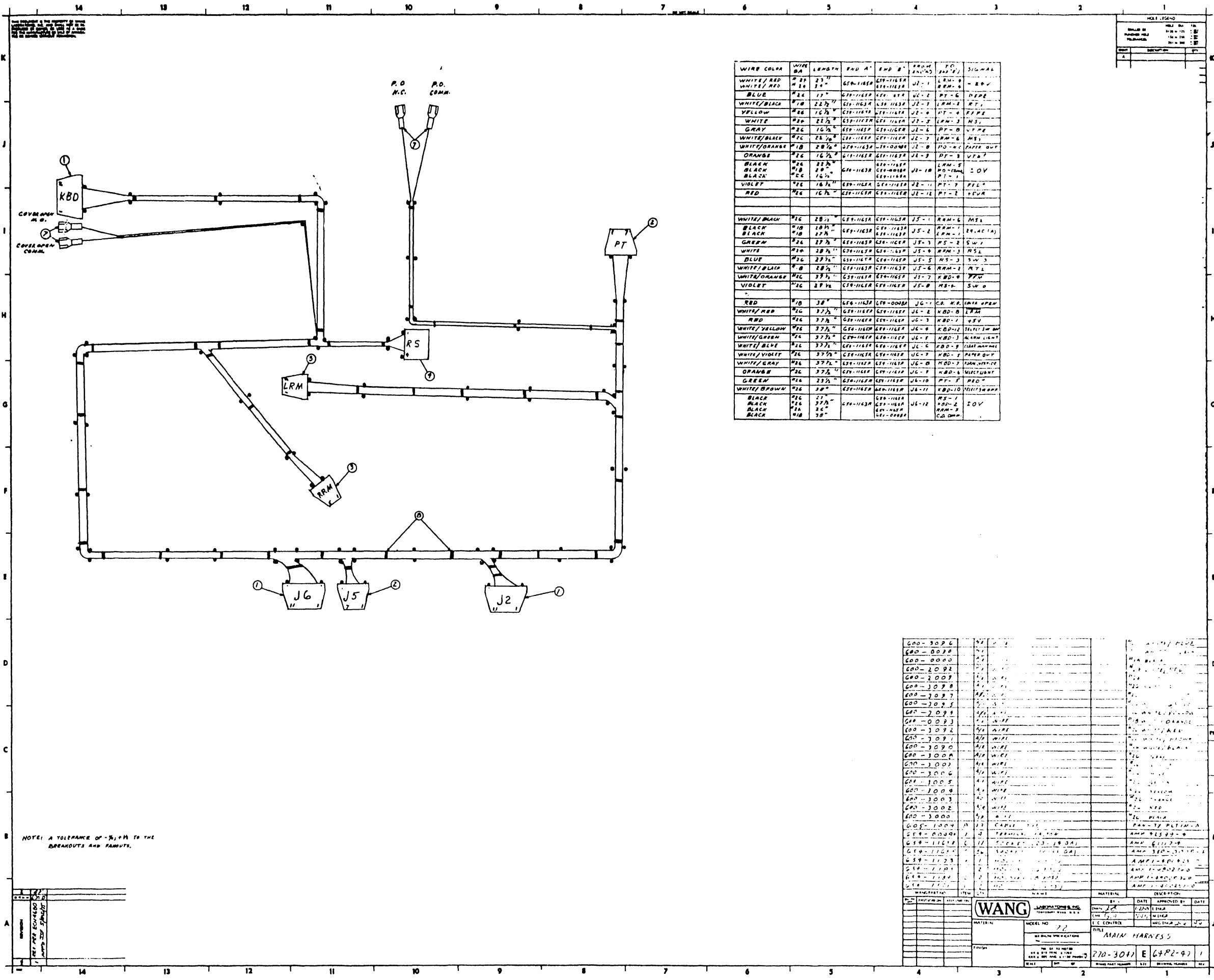

NOTE: A TOLERANCE OF $\pm 1/16$ IS TO BE MAINTAINED AT THE BREAKOUTS AND FABRICS.

WIRE LEGEND	
WIRE NO.	DESCRIPTION
1	
2	
3	

WIRE COLOR	WIRE GA.	LENGTH	END A	END B	FROM (END)	TO (END)	SIGNAL
WHITE/RED	#22	23"	CS-1158	CS-1158	J1-1	ARM-6	RRV
WHITE/RED	#10	34"	CS-1158	CS-1158	J1-1	ARM-6	RRV
BLUE	#26	17"	CS-1158	CS-1158	J1-2	PT-6	DEAR
WHITE/BLACK	#18	22 1/2"	CS-1158	CS-1158	J2-3	ARM-8	RT-1
YELLOW	#26	16 1/2"	CS-1158	CS-1158	J2-6	PT-4	FPE
WHITE	#26	22 1/2"	CS-1158	CS-1158	J2-5	ARM-3	MS
GRAY	#26	16 1/2"	CS-1158	CS-1158	J2-6	PT-8	VFPE
WHITE/BLACK	#26	28 1/2"	CS-1158	CS-1158	J2-7	ARM-6	MS
WHITE/ORANGE	#10	28 1/2"	CS-1158	CS-1158	J2-8	PO-4	PAPER OUT
ORANGE	#26	16 1/2"	CS-1158	CS-1158	J2-3	PT-3	VFB
BLACK	#26	22 1/2"	CS-1158	CS-1158	J2-10	ARM-5	DOV
BLACK	#10	28"	CS-1158	CS-1158	J2-10	ARM-5	DOV
BLACK	#26	16 1/2"	CS-1158	CS-1158	J2-11	PT-7	FPE
VIOLET	#26	16 1/2"	CS-1158	CS-1158	J2-11	PT-7	FPE
RED	#26	16 1/2"	CS-1158	CS-1158	J2-12	PT-2	VFA
WHITE/BLACK	#16	28 1/2"	CS-1158	CS-1158	J5-1	ARM-6	MS
BLACK	#10	28 1/2"	CS-1158	CS-1158	J5-2	ARM-1	REACTA
BLACK	#10	27 1/2"	CS-1158	CS-1158	J5-2	ARM-1	REACTA
GREEN	#26	27 1/2"	CS-1158	CS-1158	J5-3	MS-2	SW-1
WHITE	#26	28 1/2"	CS-1158	CS-1158	J5-4	ARM-3	RS
BLUE	#26	28 1/2"	CS-1158	CS-1158	J5-5	MS-3	SW-3
WHITE/BLACK	#10	28 1/2"	CS-1158	CS-1158	J5-6	ARM-2	ATL
WHITE/ORANGE	#16	28 1/2"	CS-1158	CS-1158	J5-7	RBD-9	SW-9
VIOLET	#26	28 1/2"	CS-1158	CS-1158	J5-8	MS-4	SW-8
RED	#10	38"	CS-1158	CS-1158	J6-1	CR. KR.	LINE OPEN
WHITE/RED	#16	37 1/2"	CS-1158	CS-1158	J6-2	RBD-8	ARM
RED	#26	37 1/2"	CS-1158	CS-1158	J6-3	RBD-7	KEY
WHITE/YELLOW	#26	37 1/2"	CS-1158	CS-1158	J6-4	RBD-12	LINE OPEN
WHITE/GREEN	#26	37 1/2"	CS-1158	CS-1158	J6-5	RBD-3	ARM LIGHT
WHITE/BLUE	#26	37 1/2"	CS-1158	CS-1158	J6-6	RBD-7	LINE OPEN
WHITE/VIOLET	#26	37 1/2"	CS-1158	CS-1158	J6-7	RBD-7	PAPER OUT
WHITE/GRAY	#26	37 1/2"	CS-1158	CS-1158	J6-8	RBD-7	LINE OPEN
ORANGE	#26	37 1/2"	CS-1158	CS-1158	J6-7	RBD-6	MULTIPLY
GREEN	#26	25 1/2"	CS-1158	CS-1158	J6-10	PT-7	PED
WHITE/BROWN	#26	38"	CS-1158	CS-1158	J6-11	RBD-10	LINE OPEN
BLACK	#26	27"	CS-1158	CS-1158	RS-1	PT-1	DOV
BLACK	#26	37 1/2"	CS-1158	CS-1158	RS-2	ARM-2	DOV
BLACK	#26	26"	CS-1158	CS-1158	RS-3	ARM-3	DOV
BLACK	#10	38"	CS-1158	CS-1158	RS-3	CA DMW	DOV

QTY	DESCRIPTION	UNIT	REMARKS
1	600-3096	WIRE	
1	600-0000	WIRE	
1	600-0000	WIRE	
1	600-1092	WIRE	
1	600-2009	WIRE	
1	600-1098	WIRE	
1	600-1097	WIRE	
1	600-1095	WIRE	
1	600-2098	WIRE	
1	600-0093	WIRE	
1	600-1092	WIRE	
1	600-1091	WIRE	
1	600-1090	WIRE	
1	600-1000	WIRE	
1	600-1001	WIRE	
1	600-1006	WIRE	
1	600-1005	WIRE	
1	600-1008	WIRE	
1	600-1003	WIRE	
1	600-1002	WIRE	
1	600-1000	WIRE	
1	600-1004	WIRE	
1	600-1000	WIRE	
1	600-1001	WIRE	
1	600-1003	WIRE	
1	600-1002	WIRE	
1	600-1000	WIRE	
1	600-1004	WIRE	
1	600-1000	WIRE	
1	600-1001	WIRE	
1	600-1003	WIRE	
1	600-1002	WIRE	
1	600-1000	WIRE	
1	600-1004	WIRE	
1	600-1000	WIRE	
1	600-1001	WIRE	
1	600-1003	WIRE	
1	600-1002	WIRE	
1	600-1000	WIRE	
1	600-1004	WIRE	
1	600-1000	WIRE	
1	600-1001	WIRE	
1	600-1003	WIRE	
1	600-1002	WIRE	
1	600-1000	WIRE	
1	600-1004	WIRE	
1	600-1000	WIRE	
1	600-1001	WIRE	
1	600-1003	WIRE	
1	600-1002	WIRE	
1	600-1000	WIRE	
1	600-1004	WIRE	
1	600-1000	WIRE	
1	600-1001	WIRE	
1	600-1003	WIRE	
1	600-1002	WIRE	
1	600-1000	WIRE	
1	600-1004	WIRE	
1	600-1000	WIRE	
1	600-1001	WIRE	
1	600-1003	WIRE	
1	600-1002	WIRE	
1	600-1000	WIRE	
1	600-1004	WIRE	
1	600-1000	WIRE	
1	600-1001	WIRE	
1	600-1003	WIRE	
1	600-1002	WIRE	
1	600-1000	WIRE	
1	600-1004	WIRE	
1	600-1000	WIRE	
1	600-1001	WIRE	
1	600-1003	WIRE	
1	600-1002	WIRE	
1	600-1000	WIRE	
1	600-1004	WIRE	
1	600-1000	WIRE	
1	600-1001	WIRE	
1	600-1003	WIRE	
1	600-1002	WIRE	
1	600-1000	WIRE	
1	600-1004	WIRE	
1	600-1000	WIRE	
1	600-1001	WIRE	
1	600-1003	WIRE	
1	600-1002	WIRE	
1	600-1000	WIRE	
1	600-1004	WIRE	
1	600-1000	WIRE	
1	600-1001	WIRE	
1	600-1003	WIRE	
1	600-1002	WIRE	
1	600-1000	WIRE	
1	600-1004	WIRE	
1	600-1000	WIRE	
1	600-1001	WIRE	
1	600-1003	WIRE	
1	600-1002	WIRE	
1	600-1000	WIRE	
1	600-1004	WIRE	
1	600-1000	WIRE	
1	600-1001	WIRE	
1	600-1003	WIRE	
1	600-1002	WIRE	
1	600-1000	WIRE	
1	600-1004	WIRE	
1	600-1000	WIRE	
1	600-1001	WIRE	
1	600-1003	WIRE	
1	600-1002	WIRE	
1	600-1000	WIRE	
1	600-1004	WIRE	
1	600-1000	WIRE	
1	600-1001	WIRE	
1	600-1003	WIRE	
1	600-1002	WIRE	
1	600-1000	WIRE	
1	600-1004	WIRE	
1	600-1000	WIRE	
1	600-1001	WIRE	
1	600-1003	WIRE	
1	600-1002	WIRE	
1	600-1000	WIRE	
1	600-1004	WIRE	
1	600-1000	WIRE	
1	600-1001	WIRE	
1	600-1003	WIRE	
1	600-1002	WIRE	
1	600-1000	WIRE	
1	600-1004	WIRE	
1	600-1000	WIRE	
1	600-1001	WIRE	
1	600-1003	WIRE	
1	600-1002	WIRE	
1	600-1000	WIRE	
1	600-1004	WIRE	
1	600-1000	WIRE	
1	600-1001	WIRE	
1	600-1003	WIRE	
1	600-1002	WIRE	
1	600-1000	WIRE	
1	600-1004	WIRE	
1	600-1000	WIRE	
1	600-1001	WIRE	
1	600-1003	WIRE	
1	600-1002	WIRE	
1	600-1000	WIRE	
1	600-1004	WIRE	
1	600-1000	WIRE	
1	600-1001	WIRE	
1	600-1003	WIRE	
1	600-1002	WIRE	
1	600-1000	WIRE	
1	600-1004	WIRE	
1	600-1000	WIRE	
1	600-1001	WIRE	
1	600-1003	WIRE	
1	600-1002	WIRE	
1	600-1000	WIRE	
1	600-1004	WIRE	
1	600-1000	WIRE	
1	600-1001	WIRE	
1	600-1003	WIRE	
1	600-1002	WIRE	
1	600-1000	WIRE	
1	600-1004	WIRE	
1	600-1000	WIRE	
1	600-1001	WIRE	
1	600-1003	WIRE	
1	600-1002	WIRE	
1	600-1000	WIRE	
1	600-1004	WIRE	
1	600-1000	WIRE	
1	600-1001	WIRE	
1	600-1003	WIRE	
1	600-1002	WIRE	
1	600-1000	WIRE	
1	600-1004	WIRE	
1	600-1000	WIRE	
1	600-1001	WIRE	
1	600-1003	WIRE	
1	600-1002	WIRE	
1	600-1000	WIRE	
1	600-1004	WIRE	
1	600-1000	WIRE	
1	600-1001	WIRE	
1	600-1003	WIRE	
1	600-1002	WIRE	
1	600-1000	WIRE	
1	600-1004	WIRE	
1	600-1000	WIRE	
1	600-1001	WIRE	
1	600-1003	WIRE	
1	600-1002	WIRE	
1	600-1000	WIRE	
1	600-1004	WIRE	
1	600-1000	WIRE	
1	600-1001	WIRE	
1	600-1003	WIRE	
1	600-1002	WIRE	
1	600-1000	WIRE	
1	600-1004	WIRE	
1	600-1000	WIRE	
1	600-1001	WIRE	
1	600-1003	WIRE	
1	600-1002	WIRE	
1	600-1000	WIRE	
1	600-1004	WIRE	
1	600-1000	WIRE	
1	600-1001	WIRE	
1	600-1003	WIRE	
1	600-1002	WIRE	
1	600-1000	WIRE	
1	600-1004	WIRE	
1	600-1000	WIRE	
1	600-1001	WIRE	
1	600-1003	WIRE	
1	600-1002	WIRE	
1	600-1000	WIRE	
1	600-1004	WIRE	
1	600-1000	WIRE	
1	600-1001	WIRE	
1	600-1003	WIRE	
1	600-1002	WIRE	
1	600-1000	WIRE	
1	600-1004	WIRE	
1	600-1000	WIRE	
1	600-1001	WIRE	
1	600-1003	WIRE	
1	600-1002	WIRE	
1	600-1000	WIRE	
1	600-1004	WIRE	
1	600-1000	WIRE	
1	600-1001	WIRE	
1	600-1003	WIRE	
1	600-1002	WIRE	
1	600-1000	WIRE	
1	600-1004	WIRE	
1	600-1000	WIRE	
1	600-1001	WIRE	
1	600-1003	WIRE	
1	600-1002	WIRE	
1	600-1000	WIRE	

7-3

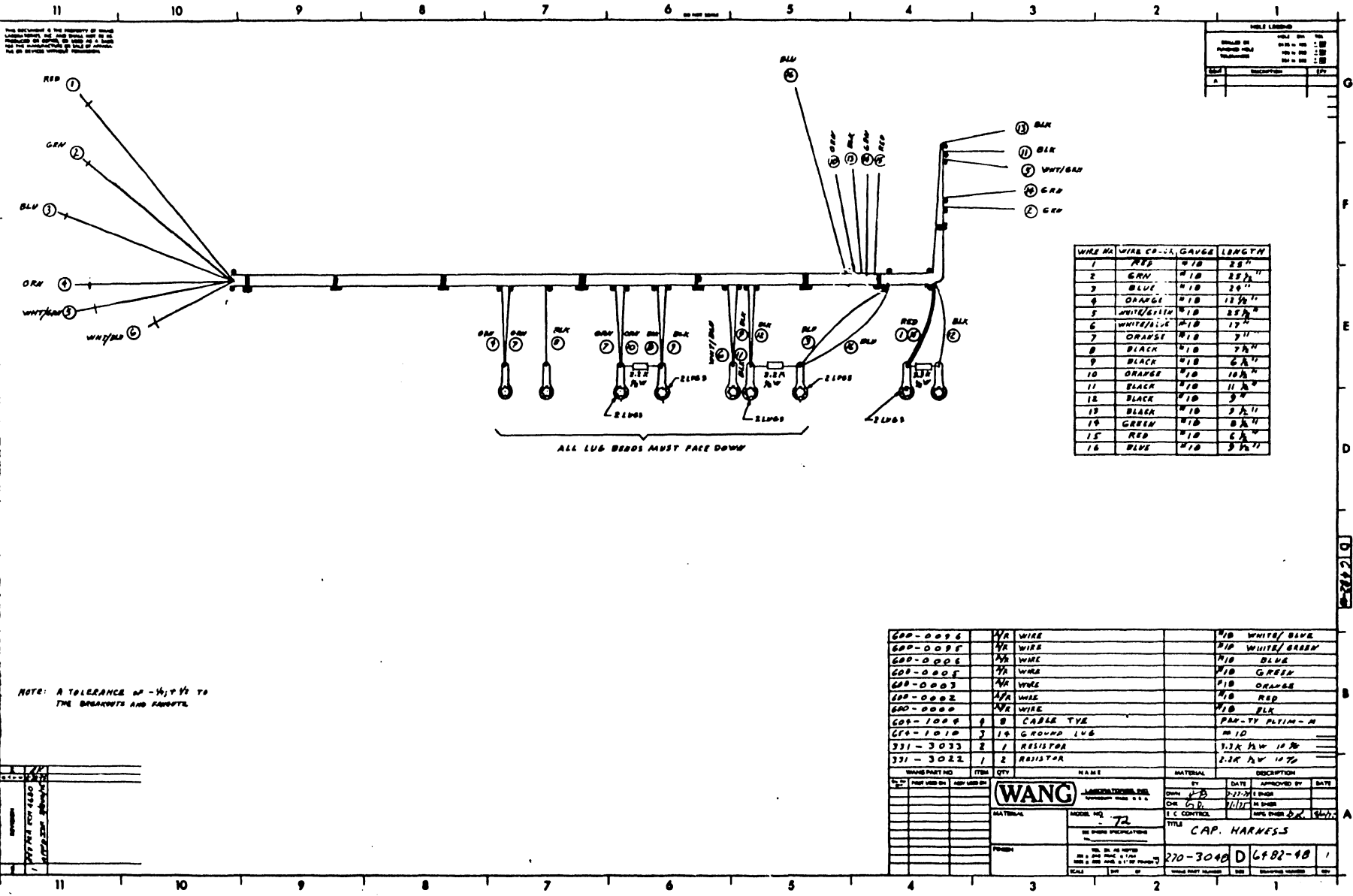

The dimensions of the components of this harness are given in inches and fractions of an inch. Dimensions are given in millimeters and fractions of a millimeter where indicated. All dimensions are to be held unless otherwise indicated.

NOTE: A TOLERANCE OF $\pm 1/16$ TO THE BREAKOUTS AND TABS.

DATE	BY	REVISION
10/25/54	WJ	1
11/15/54	WJ	2

WIRE LISTING	
WIRE NO.	DESCRIPTION
1	RED
2	GRN
3	BLU
4	ORN
5	WHY/GRN
6	WHY/BLK

WIRE NO.	WIRE CO.-L1.	GAUGE	LENGTH
1	RED	#10	25"
2	GRN	#10	25 1/2"
3	BLU	#10	24"
4	ORNGE	#10	12 1/2"
5	WHITE/GRN	#10	25 1/2"
6	WHITE/BLK	#10	17"
7	ORNGE	#10	7"
8	BLACK	#10	7 1/2"
9	BLACK	#10	6 1/2"
10	ORNGE	#10	10 1/2"
11	BLACK	#10	11 1/2"
12	BLACK	#10	9"
13	BLACK	#10	7 1/2"
14	GREEN	#10	8 1/2"
15	RED	#10	6 1/2"
16	BLU	#10	9 1/2"

WIRE PART NO.	ITEM	QTY	NAME	MATERIAL	DESCRIPTION
600-0096	1/8	WIRE		#10	WHITE/BLU
600-0095	1/8	WIRE		#10	WHITE/GRN
600-0094	1/8	WIRE		#10	BLU
600-0093	1/8	WIRE		#10	GRN
600-0092	1/8	WIRE		#10	ORNGE
600-0091	1/8	WIRE		#10	RED
600-0090	1/8	WIRE		#10	BLK
600-1000	1	CABLE TIE			PAN-TY PLTIN-M
600-1010	3	GROUND LUG		#10	
331-3033	2	RESISTOR		1/2W 10%	
331-3022	2	RESISTOR		1/2W 10%	

DATE	BY	APPROVED BY	DATE
10/25/54	WJ	WJ	11/15/54
11/15/54	WJ	WJ	11/15/54

WANG	LABORATORY	DATE	11/15/54
MODEL NO.	72	TITLE	CAP. HARNESS
FIG. NO.	270-3040	REV.	D 6482-48 1

11 10 9 8 7 6 5 4 3 2 1

THIS DOCUMENT IS THE PROPERTY OF WANG
 LABORATORIES, INC. AND SHOULD NOT BE
 REPRODUCED OR TRANSMITTED IN ANY FORM OR
 BY ANY MEANS, ELECTRONIC OR MECHANICAL,
 INCLUDING PHOTOCOPYING, RECORDING, OR BY
 ANY INFORMATION STORAGE AND RETRIEVAL
 SYSTEMS, WITHOUT PERMISSION.

WANG LABORATORIES			
DESIGNED BY	DATE	REV.	BY

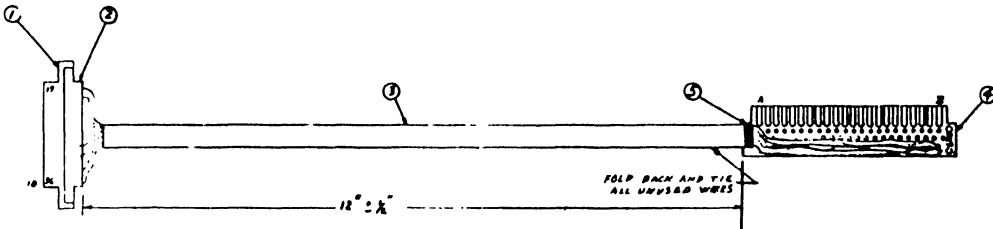

SIGNAL	COND. PIN NO.	WIRE NO.	TO 6703
DATA STROBE	1	1	21
DATA 1	2	2	18
DATA 2	3	3	16
DATA 3	4	4	17
DATA 4	5	5	20
DATA 5	6	6	15
DATA 6	7	7	11
DATA 7	8	8	19
DATA 8	9	9	12
ACKLE	10	10	22
BSY	11	11	3
PO	12	12	9
SLBT	13	13	8
TRDY	14	14	10
OSCT	15	15	4
IOV	16	16	5
CHASSIS GND	17	17	6
+5V R	18	18	13

SIGNAL	COND. PIN NO.	WIRE NO.	TO 6703
IOV	19	19	A
IOV	20	20	G
IOV	21	21	M
IOV	22	22	N
IOV	23	23	P
IOV	24	24	R
IOV	25	25	S
IOV	26	26	T
IOV	27	27	U
IOV	28	28	V
IOV	29	29	W
IOV	30	30	B
SP	31	31	E
IOV	32	32	7
SPKR	33	33	K
WRT	34	34	J
IOV	35	35	10
IOV	36	36	14

7-4

ITEM	WANG PART #	DESCRIPTION
1	350-2066	CONN., 36 POS FEMALE CHAMP AMP-2-552475-1
2	350-4225	STRAIN RELIEF, 36 POS AMP 1-557297-1
3	420-0004	CABLE, 26 GA, 36/C
4	510-6703	6703, P.C. BOARD
5	605-1004	CABLE TIE, PAN-TY PLTIN-M
6	660-0203	SOLDER, 22 GA. SWS3-37

REV.	DATE	BY	DESCRIPTION

WANG PART NO.	REV.	QTY.	NAME	DATE	DESCRIPTION

11 10 9 8 7 6 5 4 3 2 1

7-5

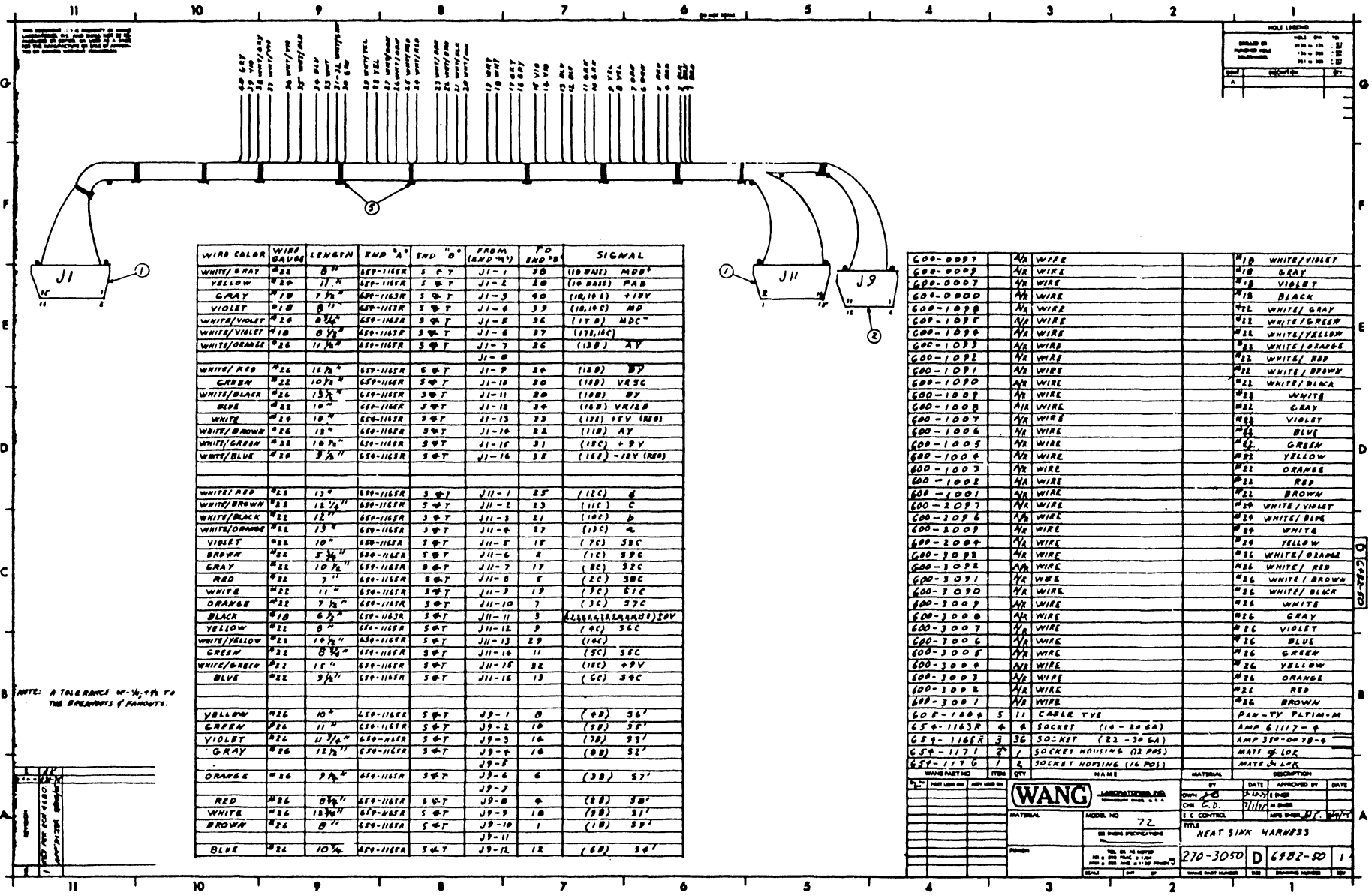

WIRE COLOR	WIRE GAUGE	LENGTH	END "A"	END "B"	FROM (END "A")	TO (END "B")	SIGNAL
WHITE/GRAY	#22	8"	6P-116R	S ⊕ T	J1-1	20	(10 BASE) MDP*
YELLOW	#20	7 1/4"	6P-116R	S ⊕ T	J1-2	20	(10 BASE) PAB
GRAY	#20	7 1/4"	6P-116R	S ⊕ T	J1-3	20	(10,15) +18V
VIOLET	#20	8 1/4"	6P-116R	S ⊕ T	J1-4	20	(10,15) AD
WHITE/VIOLET	#20	8 1/4"	6P-116R	S ⊕ T	J1-5	26	(17,18) MDC
WHITE/VIOLET	#20	8 1/4"	6P-116R	S ⊕ T	J1-6	27	(17,18) MDC
WHITE/ORANGE	#26	17 1/4"	6P-116R	S ⊕ T	J1-7	26	(18) XY
WHITE/RED	#26	12 1/4"	6P-116R	S ⊕ T	J1-9	24	(18) BY
GREEN	#22	10 1/4"	6P-116R	S ⊕ T	J1-10	20	(18) VR3C
WHITE/BLACK	#26	13 1/4"	6P-116R	S ⊕ T	J1-11	20	(18) BY
BLUE	#22	10"	6P-116R	S ⊕ T	J1-12	26	(18) VR2B
WHITE	#20	10"	6P-116R	S ⊕ T	J1-13	23	(18) +V (MD)
WHITE/BROWN	#26	13"	6P-116R	S ⊕ T	J1-14	24	(18) AY
WHITE/GREEN	#22	10 1/4"	6P-116R	S ⊕ T	J1-15	21	(18) +V
WHITE/BLUE	#20	3 1/4"	6P-116R	S ⊕ T	J1-16	25	(18) -18V (MD)
WHITE/RED	#22	13"	6P-116R	S ⊕ T	J11-1	25	(12) d
WHITE/BROWN	#22	12 1/4"	6P-116R	S ⊕ T	J11-2	23	(11) c
WHITE/BLACK	#22	12 1/4"	6P-116R	S ⊕ T	J11-3	21	(10) b
WHITE/ORANGE	#22	13"	6P-116R	S ⊕ T	J11-4	27	(10) e
VIOLET	#22	10"	6P-116R	S ⊕ T	J11-5	18	(7) 3BC
BROWN	#22	5 1/4"	6P-116R	S ⊕ T	J11-6	2	(1) 3PC
GRAY	#22	10 1/4"	6P-116R	S ⊕ T	J11-7	17	(8) 3CC
RED	#22	7 1/4"	6P-116R	S ⊕ T	J11-8	5	(2) 3BC
WHITE	#22	11"	6P-116R	S ⊕ T	J11-9	19	(7) 3TC
ORANGE	#22	7 1/4"	6P-116R	S ⊕ T	J11-10	7	(3) 37C
BLACK	#20	6 1/4"	6P-116R	S ⊕ T	J11-11	3	(1) 3CC
YELLOW	#22	8"	6P-116R	S ⊕ T	J11-12	9	(4) 3CC
WHITE/YELLOW	#22	10 1/4"	6P-116R	S ⊕ T	J11-13	29	(14) 3CC
GREEN	#22	8 1/4"	6P-116R	S ⊕ T	J11-14	11	(5) 3CC
WHITE/GREEN	#22	15 1/4"	6P-116R	S ⊕ T	J11-15	22	(10) +V
BLUE	#22	3 1/4"	6P-116R	S ⊕ T	J11-16	13	(6) 34C
YELLOW	#26	10"	6P-116R	S ⊕ T	J9-1	0	(4) 36'
GREEN	#26	11"	6P-116R	S ⊕ T	J9-2	10	(5) 35'
VIOLET	#22	11 1/4"	6P-116R	S ⊕ T	J9-3	14	(7) 33'
GRAY	#26	12 1/4"	6P-116R	S ⊕ T	J9-4	16	(8) 32'
ORANGE	#26	3 1/4"	6P-116R	S ⊕ T	J9-5	6	(3) 37'
RED	#26	8 1/4"	6P-116R	S ⊕ T	J9-6	4	(5) 38'
WHITE	#26	12 1/4"	6P-116R	S ⊕ T	J9-7	10	(5) 31'
BROWN	#26	8"	6P-116R	S ⊕ T	J9-8	1	(1) 39'
BLUE	#26	10 1/4"	6P-116R	S ⊕ T	J9-9	12	(6) 34'

NOTE: A TOLERANCE OF 1/4" TO 1/2" IS TO BE MAINTAINED IN ALL DIMENSIONS.

WIRE NO.	WIRE	WIRE	WIRE
600-0007	1/4" WIRE		#18 WHITE/VIOLET
600-0007	1/4" WIRE		#18 GRAY
600-0007	1/4" WIRE		#18 VIOLET
600-0000	1/4" WIRE		#18 BLACK
600-1000	1/4" WIRE		#22 WHITE/GRAY
600-1000	1/4" WIRE		#22 WHITE/GREEN
600-1000	1/4" WIRE		#22 WHITE/YELLOW
600-1000	1/4" WIRE		#22 WHITE/ORANGE
600-1000	1/4" WIRE		#22 WHITE/RED
600-1001	1/4" WIRE		#22 WHITE/BROWN
600-1000	1/4" WIRE		#22 WHITE/BLACK
600-1000	1/4" WIRE		#22 WHITE
600-1000	1/4" WIRE		#22 GRAY
600-1007	1/4" WIRE		#22 VIOLET
600-1006	1/4" WIRE		#22 BLUE
600-1005	1/4" WIRE		#22 GREEN
600-1004	1/4" WIRE		#22 YELLOW
600-1003	1/4" WIRE		#22 ORANGE
600-1002	1/4" WIRE		#22 RED
600-1001	1/4" WIRE		#22 BROWN
600-2007	1/4" WIRE		#20 WHITE/VIOLET
600-2006	1/4" WIRE		#20 WHITE/GRAY
600-2005	1/4" WIRE		#20 WHITE/BLACK
600-2004	1/4" WIRE		#20 WHITE/RED
600-2003	1/4" WIRE		#20 WHITE/BROWN
600-2002	1/4" WIRE		#20 WHITE/BLACK
600-2001	1/4" WIRE		#20 WHITE
600-2000	1/4" WIRE		#20 GRAY
600-2000	1/4" WIRE		#20 VIOLET
600-2000	1/4" WIRE		#20 BLUE
600-2000	1/4" WIRE		#20 GREEN
600-2000	1/4" WIRE		#20 YELLOW
600-2000	1/4" WIRE		#20 ORANGE
600-2000	1/4" WIRE		#20 RED
600-2000	1/4" WIRE		#20 BROWN
600-1000	5 1/2" CABLE TIE		PAN-TY PLATINUM
650-1163R	6 1/2" SOCKET (14-20 GA)		AMP 61117-6
650-1168R	3 3/8" SOCKET (22-30 GA)		AMP 300-0078-6
650-1171	2" SOCKET HOUSING (12 PPS)		MATE 4 LOCK
650-1176	1 1/2" SOCKET HOUSING (16 PPS)		MATE 4 LOCK

WANG LABORATORIES, INC. 1000 W. 12TH AVENUE, DENVER, CO. 80202

DATE: 7/1/77 BY: [Signature]

PROJECT: HEAT SINK HARNESS

REV: 270-3050 D 6982-50 1

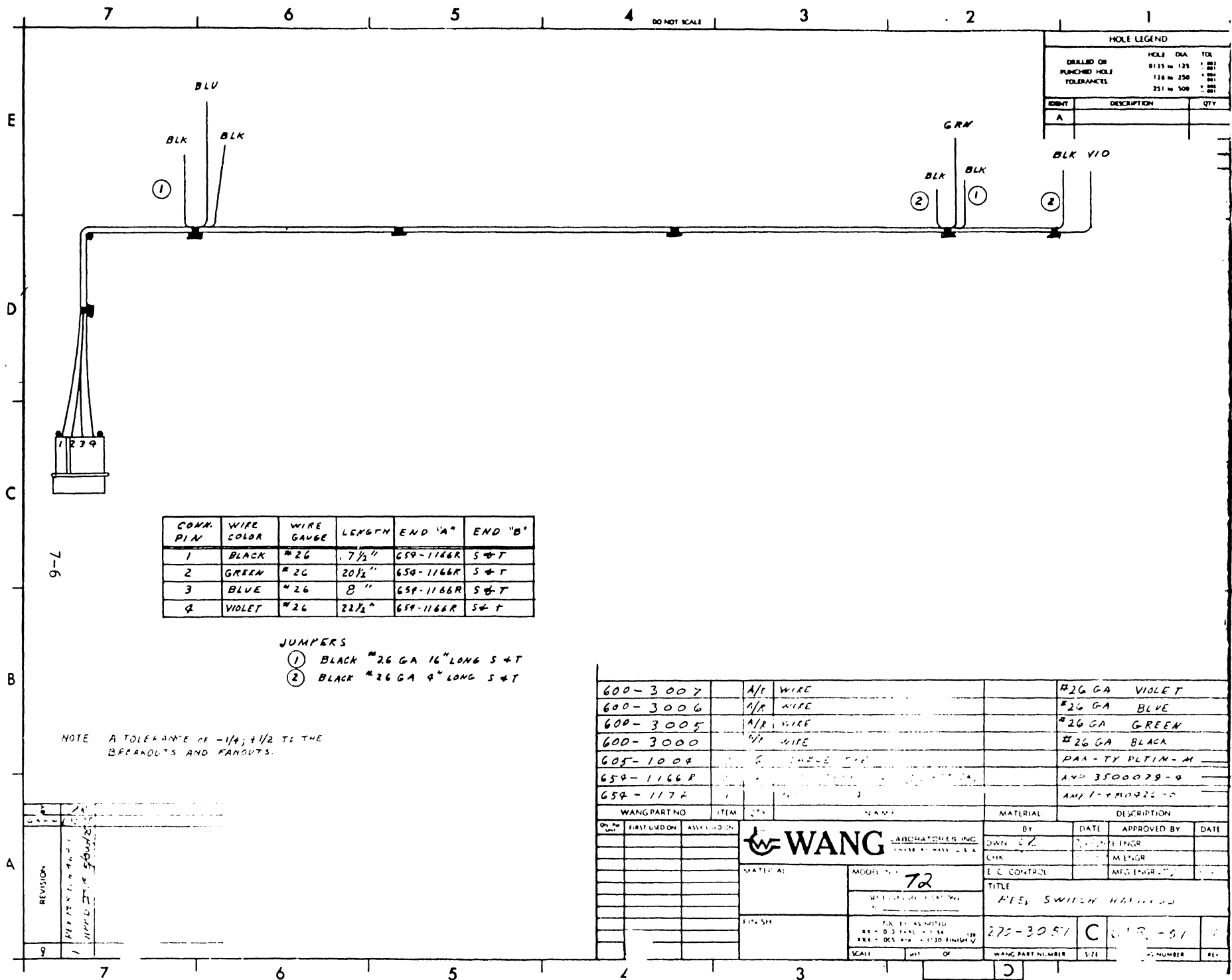

HOLE LEGEND		
DRILLED OR	HOLE DIA.	TOL.
PUNCHED HOLE	0.135 to 0.250	+ .002
TOLERANCES	0.251 to 0.500	+ .004
	0.501 to 1.000	+ .008
	1.001 to 2.000	+ .015
	2.001 to 5.000	+ .030
	5.001 to 10.000	+ .060
	10.001 to 25.000	+ .125
	25.001 to 50.000	+ .250
	50.001 to 100.000	+ .500
	100.001 to 250.000	+ 1.000
	250.001 to 500.000	+ 2.000
	500.001 to 1000.000	+ 4.000

CONN. PIN	WIRE COLOR	WIRE GAUGE	LENGTH	END 'A'	END 'B'
1	BLACK	#26	.7 1/2"	659-1166R	S + T
2	GREEN	#26	20 1/2"	659-1166R	S + T
3	BLUE	#26	8"	659-1166R	S + T
4	VIOLET	#26	22 1/2"	659-1166R	S + T

- JUMPERS
- ① BLACK #26 GA 16" LONG S + T
 - ② BLACK #26 GA 4" LONG S + T

NOTE: A TOLERANCE OF -1/4; +1/2 TO THE BREAKOUTS AND FANOUTS.

600-3007	A/R	WIRE	#26 GA	VIOLET
600-3006	A/R	WIRE	#26 GA	BLUE
600-3005	A/R	WIRE	#26 GA	GREEN
600-3000	A/R	WIRE	#26 GA	BLACK
605-1004		6 INCHES STR		PAA-TX PLTIN-M
659-1166R				AMP 3500079-9
659-1172				AMP 1-100920-0
WANG PART NO	ITEM	QTY	MATERIAL	DESCRIPTION
DATE	FIRST USED ON	APPROVED ON	BY	DATE
			OWN E.K.	ENGR
			CHK	MEMOR
			E.C. CONTROL	MEG ENGR
			TITLE	
				REC SWITCH HARNESS
			275-3051	C
			SCALE	DATE
			WANG PART NUMBER	SIZE
			NUMBER	REV

REVISION	DATE	BY	DESCRIPTION
1			REVISIONS
2			APPROVED

7-7

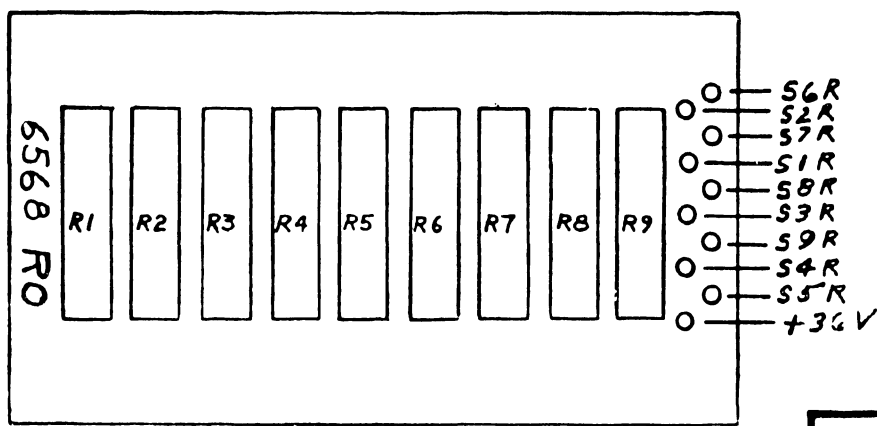
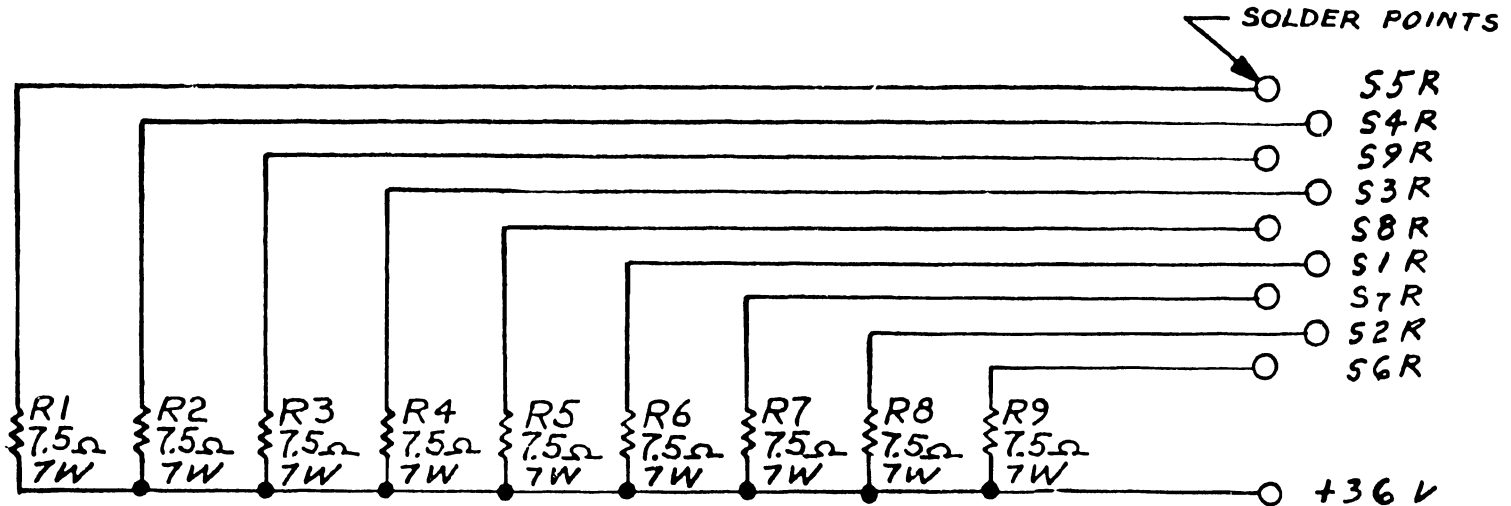

COMPONENT LAYOUT

COMPONENT	W.L. PART NO.
R1 - R9	334-0025

FOR INTERCONNECTION
SEE E6635-999 E-REV

SH. 4 OF 5



BY	E.K.	G.D.	JB
DATE	3-21-75	5-18-75	8-14-75
REVISIONS	ORIGINATED PER W.A. 401 APPD. P.P. 1/6	REL. TO Prod APPD. P.P. 5-15-75	REV. PER R.F.A. 1786 APPD. P.P. 1/6
A	0/0	1/0	

210-6568

WANG LABORATORIES, INC. 
TEWKSBURY, MASS. U. S. A.

MODEL NO.	DRAWN <i>E.K.</i>	4-8-75	APPD. <i>R. Ch...</i>	1-20-75
72	CHECKED <i>G.D.</i>	4/15/75	APPD.	
TITLE SCHEMATIC LOGIC RESISTOR BRACKET				
W.O. NO.	SCALE	DWG. NO.	REV	
401	<i>H</i>	A 6568	1	

DO NOT SCALE

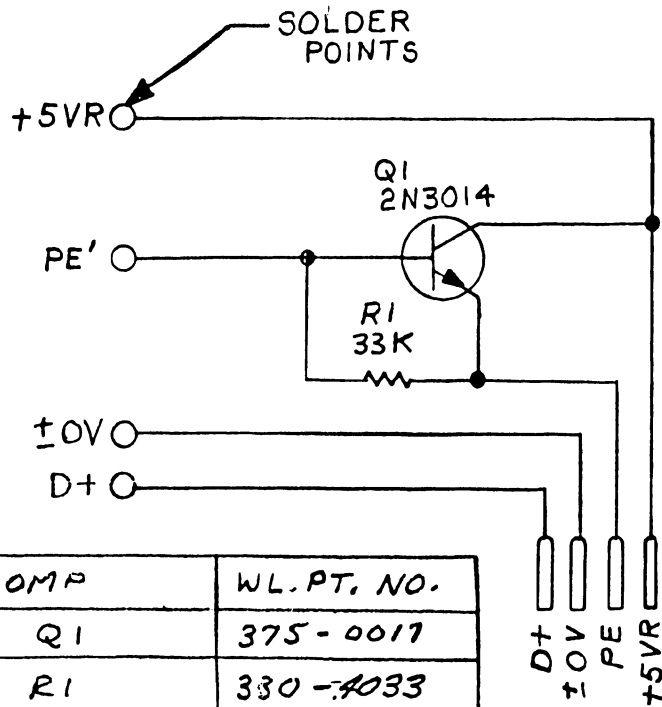

COMP	WL. PT. NO.
Q1	375-0017
R1	330-4033

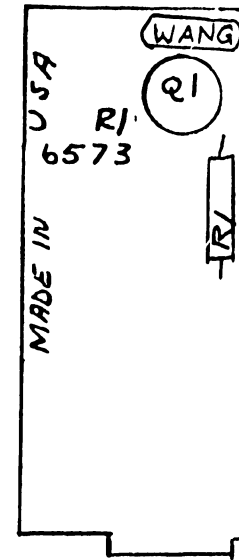

COMPONENT LAYOUT

E REV

1.

8-7

NO.	REVISION	DATE	BY
0/10	RELEASED TO PRODUCTION PER REF #1344 APP'D: P. Ricketts	1/14/75	EBA
1/1	RESUBMIT KI WAS 100K 1/4W, PER ECN #4822 5/28/75 APP'D: Robert Chen	5-21-75	EBA

WANG LABORATORIES, INC. 
TEWKSBURY, MASS. U. S. A.

MODEL NO. 72	DRAWN AK	DATE 7-13-75	APPD. Robert Chen	DATE 5/28/75
	CHECKED AK	DATE 10-15-75	APPD.	

TITLE
FINGER BOARD #2

WG. NO. SHT 4 OF 5	SCALE	DWG. NO. A 6573	REV 1
-----------------------	-------	--------------------	----------

DO NOT SCALE

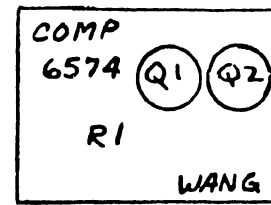
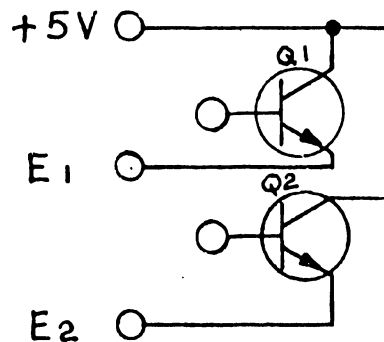

COMPONENT LAYOUT

COMPONENT	W.L. PART NO.
Q1, Q2	375-2104

E.REV.



WLI# 210-6574

11-7-74

NO.	REVISION	BY	DATE
0/0	REVISED PER D.C.R. # 51 APP'D H.G.	11/8/74	7/4/75
1/0	REV. PER APP'D RFA # 1763 H.S.	7/4/75	7/5/75

WANG LABORATORIES, INC. TEWKSBURY, MASS. U. S. A.			
MODEL NO. 72	DRAWN RK 9-1-74	APPD	
	CHECKED APP 11-7-74	APPD	
TITLE PHOTOTRANSISTOR MATRIX PRINTER			
W.O. NO.	SCALE	DWG. NO. A 6574	REV 0

DO NOT SCALE

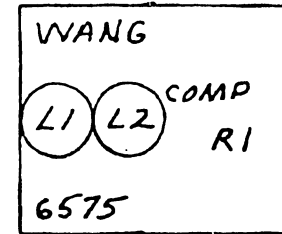
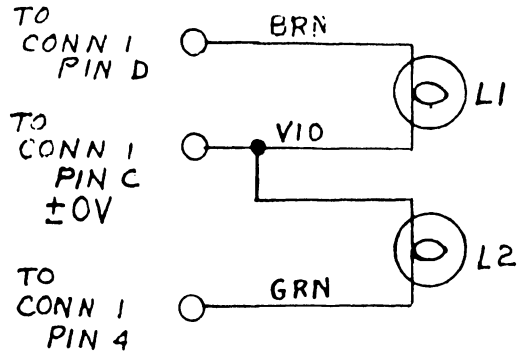

COMPONENT LAYOUT

COMPONENT	W.L. PART NO.
L1, L2	380-0104

E-REV

0

7-10

NO.	REVISION	BY	DATE	APP'D
B	REVISED: PER D.C.R.#252. APP'D H.G.	F.S.	11/24/75	G.D.
	REL TO PROD		3/26/75	
	APP'D H.S 8-4-75			

WLI# 210-6575

Sheet 4 of 5

WANG LABORATORIES, INC. 			
TEWKSBURY, MASS. U. S. A.			
MODEL NO.	DRAWN	APPD	
72	CHECKED	APPD	
TITLE LED (LAMP) MTG MATRIX PRINTER			
W.O. NO.	SCALE	DWG. NO.	REV
	—	A 6575	0

THIS DOCUMENT IS THE PROPERTY OF WANG LABORATORIES, INC. AND SHALL NOT BE REPRODUCED OR COPIED, OR USED AS A BASIS FOR THE MANUFACTURE OR SALE OF APPARATUS OR DEVICES WITHOUT PERMISSION.

HOLE LEGEND		
DRILLED OR PUNCHED HOLES	HOLE DIA.	TOL.
	0.125 to 0.250	±0.010
	0.250 to 0.500	±0.015
	0.500 to 1.000	±0.020
	1.000 to 2.000	±0.030
	2.000 to 5.000	±0.050
IDENT.	DESCRIPTION	QTY.
A		

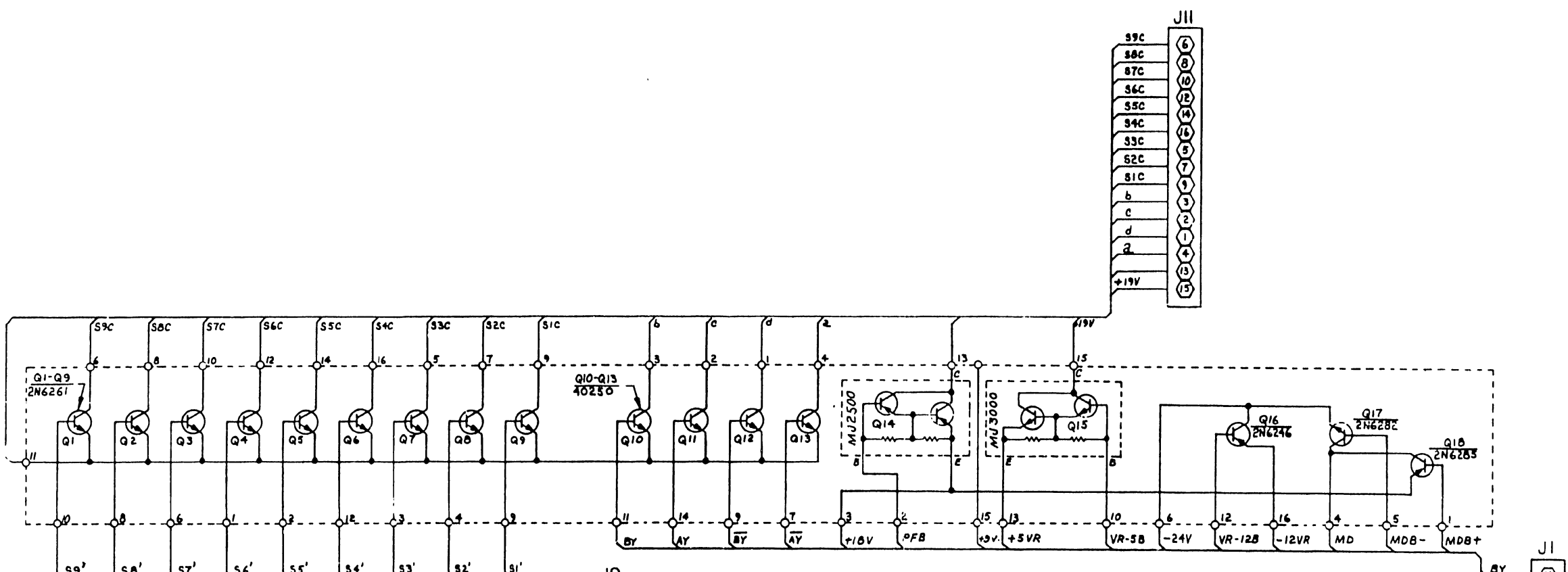

COMPONENT	W.L. PART NO.
Q1-Q9	375-1045
Q10-Q13	375-1028
Q14	375-1044
Q15	375-1043
Q16	375-1029
Q17	375-1046
Q18	375-1047

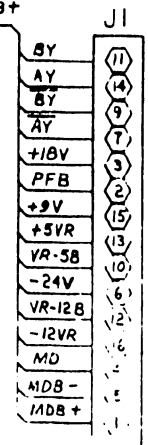
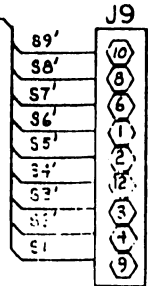
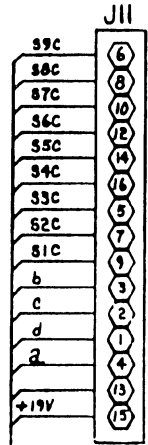
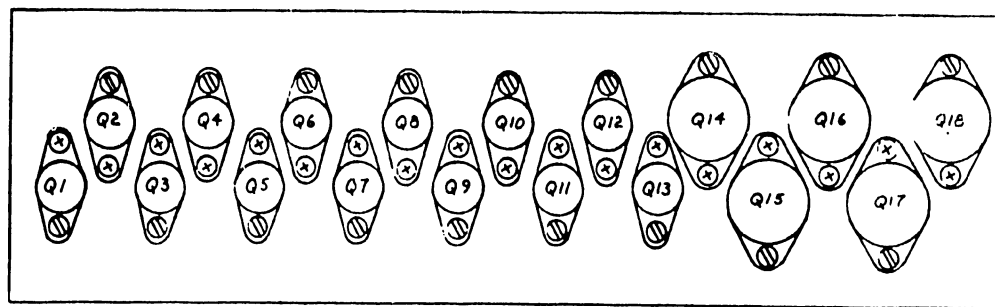

REV.	DATE	BY	DESCRIPTION
1	2-18-75	EX	ORIG PER
2		E-047	APP'D: D.C.

WANG PART NO.	ITEM	QTY.	NAME	MATERIAL	DESCRIPTION
	FIRST USED ON	ASSEMBY USED ON			
			WANG LABORATORIES, INC. TEMPERATURE MADE, U.S.A.	BY	DATE
				DATE	APPROVED BY
				CHK	DATE
				E.C. CONTROL	MFG. ENGR.
				TITLE	
				NEAT SWK ASSEMBLY	
				TOL. OR AS NOTED	
				SEE 2. DIM. FRAC. 1/64	
				SEE 3. DIM. FRAC. 1/32 FINISH	
				SCALE	
				270-0	D 6635-998
				WANG PART NUMBER	SIZE
				DRAWING NUMBER	REV.

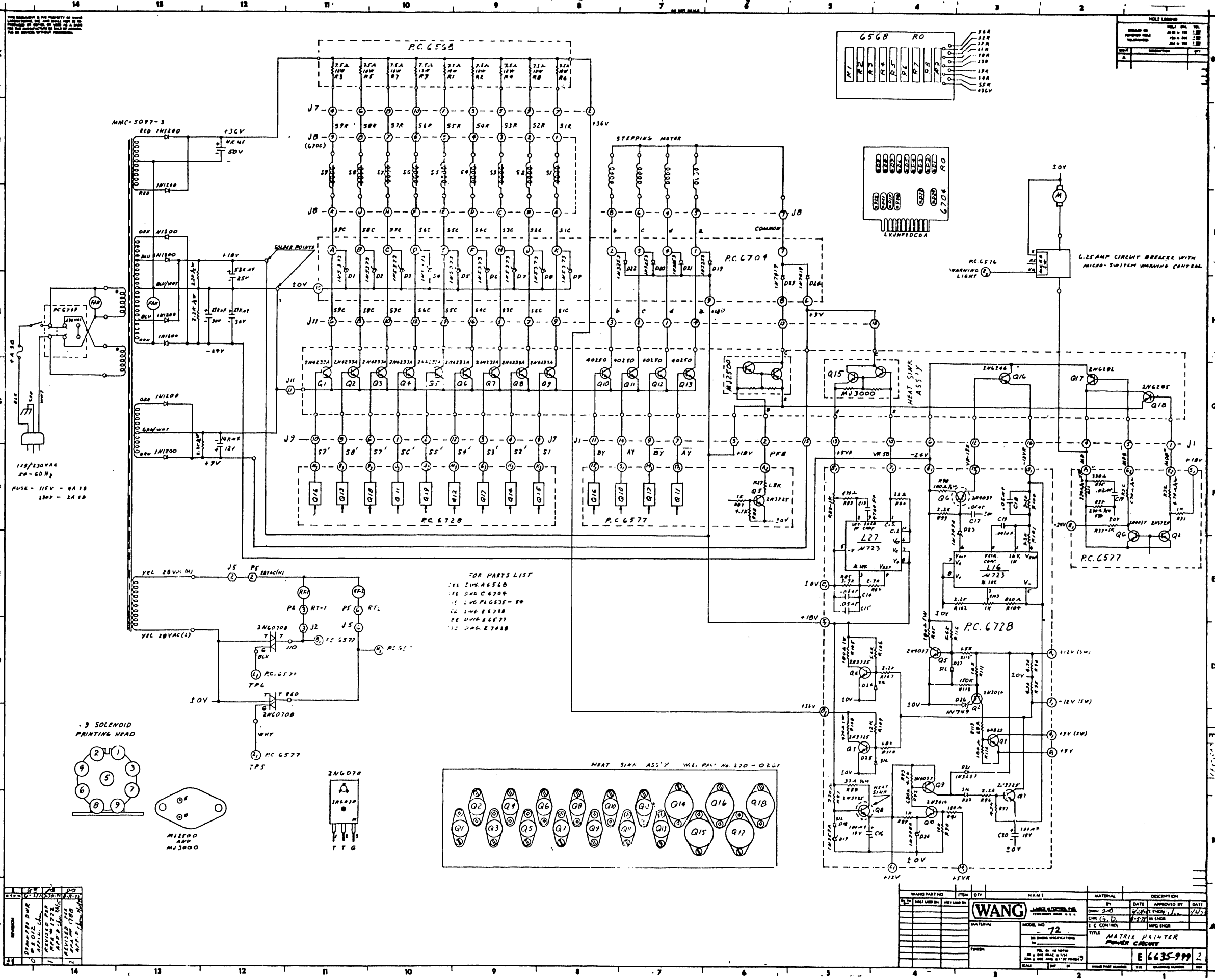

FOR PARTS LIST
 SEE DRAWING 6560
 SEE DRAWING 6709
 SEE DRAWING 6535-FO
 SEE DRAWING 6718
 SEE DRAWING 6577
 SEE DRAWING 6728

REV	DATE	BY	CHKD	DESCRIPTION
1	11/15/66	W.D.	W.D.	REVISED FOR MANUFACTURE
2	11/15/66	W.D.	W.D.	REVISED FOR MANUFACTURE

WARRANTY PART NO.	ITEM	QTY	NAME	MATERIAL	DESCRIPTION
72	PC 6577	1	BRIDGE RECTIFIER	1N4007	BRIDGE RECTIFIER
72	PC 6709	1	STEPPING MOTOR	40170	STEPPING MOTOR
72	PC 6728	1	DRIVER CIRCUIT	2N4070B, 2N4078, 2N4079, 2N4080, 2N4081, 2N4082, 2N4083, 2N4084, 2N4085, 2N4086, 2N4087, 2N4088, 2N4089, 2N4090, 2N4091, 2N4092, 2N4093, 2N4094, 2N4095, 2N4096, 2N4097, 2N4098, 2N4099, 2N4100, 2N4101, 2N4102, 2N4103, 2N4104, 2N4105, 2N4106, 2N4107, 2N4108, 2N4109, 2N4110, 2N4111, 2N4112, 2N4113, 2N4114, 2N4115, 2N4116, 2N4117, 2N4118, 2N4119, 2N4120, 2N4121, 2N4122, 2N4123, 2N4124, 2N4125, 2N4126, 2N4127, 2N4128, 2N4129, 2N4130, 2N4131, 2N4132, 2N4133, 2N4134, 2N4135, 2N4136, 2N4137, 2N4138, 2N4139, 2N4140, 2N4141, 2N4142, 2N4143, 2N4144, 2N4145, 2N4146, 2N4147, 2N4148, 2N4149, 2N4150, 2N4151, 2N4152, 2N4153, 2N4154, 2N4155, 2N4156, 2N4157, 2N4158, 2N4159, 2N4160, 2N4161, 2N4162, 2N4163, 2N4164, 2N4165, 2N4166, 2N4167, 2N4168, 2N4169, 2N4170, 2N4171, 2N4172, 2N4173, 2N4174, 2N4175, 2N4176, 2N4177, 2N4178, 2N4179, 2N4180, 2N4181, 2N4182, 2N4183, 2N4184, 2N4185, 2N4186, 2N4187, 2N4188, 2N4189, 2N4190, 2N4191, 2N4192, 2N4193, 2N4194, 2N4195, 2N4196, 2N4197, 2N4198, 2N4199, 2N4200	DRIVER CIRCUIT

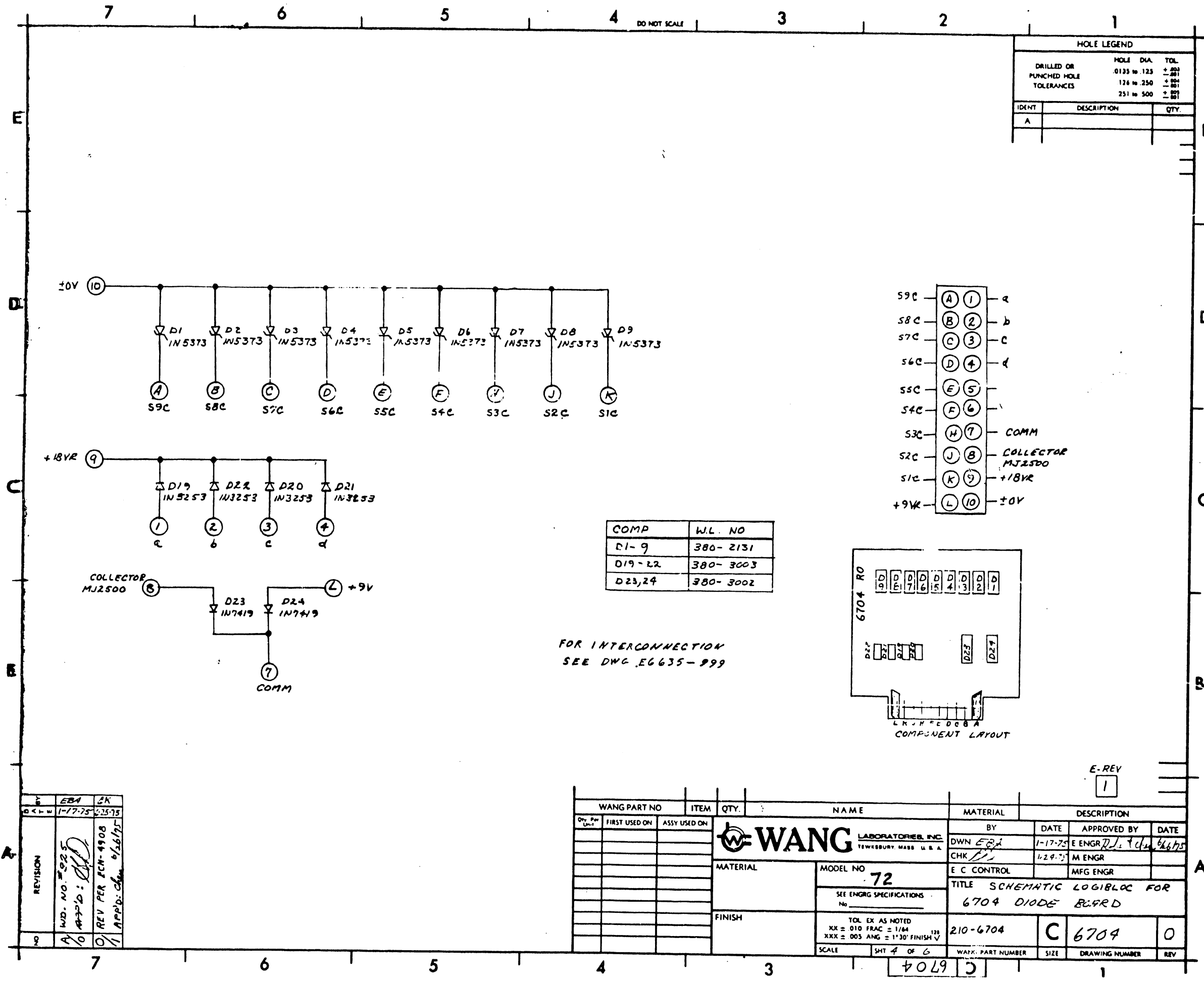

HOLE LEGEND		
DRILLED OR PUNCHED HOLE	HOLE DIA.	TOL.
	.0125 to .125	+ .003
	.126 to .250	+ .004
	.251 to .500	+ .007
IDENT	DESCRIPTION	QTY.
A		

COMP	W.L. NO
D1-9	380-2131
D19-22	380-3003
D23,24	380-3002

FOR INTERCONNECTION
SEE DWG. EG635-999

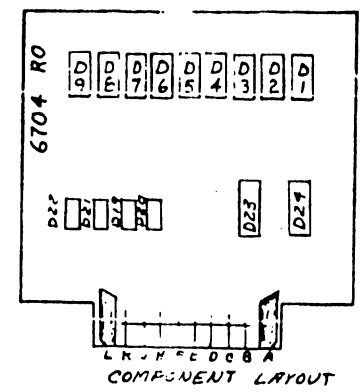

REV	BY	CHK	DATE
1	EBA	JK	1-17-75

REVISION

WD. NO. 5925
APP'D: [Signature]

REV PER FCN-9908
APP'D: [Signature]

WANG PART NO	ITEM	QTY.	NAME	MATERIAL	DESCRIPTION
210-6704			WANG LABORATORIES, INC. NEWBURY, MASS. U.S.A.		
			MODEL NO. 72		
			SEE ENGR SPECIFICATIONS		
			TOL EX AS NOTED XX = 010 FRAC = 1/64 XXX = 005 ANG = 1'30" FINISH	210-6704	C 6704
			SCALE: SH 4 OF 6	WANG PART NUMBER	SIZE: DRAWING NUMBER

E-REV
1

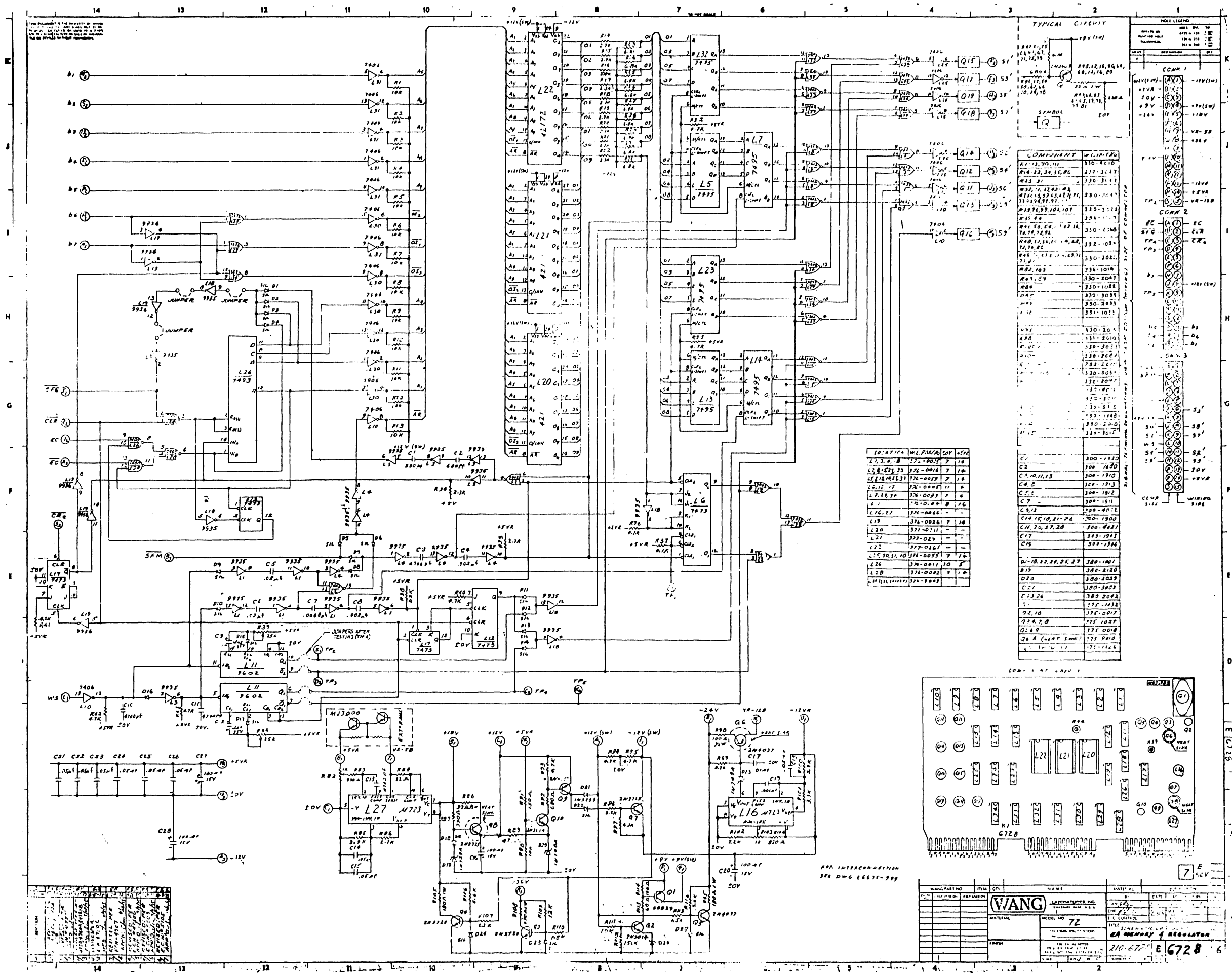

COMPONENT

REF. NO.	DESCRIPTION	QTY.	VALUE
R1	RESISTOR	10	10K
R2	RESISTOR	10	10K
R3	RESISTOR	10	10K
R4	RESISTOR	10	10K
R5	RESISTOR	10	10K
R6	RESISTOR	10	10K
R7	RESISTOR	10	10K
R8	RESISTOR	10	10K
R9	RESISTOR	10	10K
R10	RESISTOR	10	10K
C1	CAPACITOR	10	100PF
C2	CAPACITOR	10	100PF
C3	CAPACITOR	10	100PF
C4	CAPACITOR	10	100PF
C5	CAPACITOR	10	100PF
C6	CAPACITOR	10	100PF
C7	CAPACITOR	10	100PF
C8	CAPACITOR	10	100PF
C9	CAPACITOR	10	100PF
C10	CAPACITOR	10	100PF
C11	CAPACITOR	10	100PF
C12	CAPACITOR	10	100PF
C13	CAPACITOR	10	100PF
C14	CAPACITOR	10	100PF
C15	CAPACITOR	10	100PF
D1	DIODE	10	1N4148
D2	DIODE	10	1N4148
D3	DIODE	10	1N4148
D4	DIODE	10	1N4148
D5	DIODE	10	1N4148
D6	DIODE	10	1N4148
D7	DIODE	10	1N4148
D8	DIODE	10	1N4148
D9	DIODE	10	1N4148
D10	DIODE	10	1N4148

IC: AT 104

REF. NO.	DESCRIPTION	QTY.	VALUE
L20	IC	10	7420
L21	IC	10	7421
L22	IC	10	7422
L23	IC	10	7423
L24	IC	10	7424
L25	IC	10	7425
L26	IC	10	7426
L27	IC	10	7427

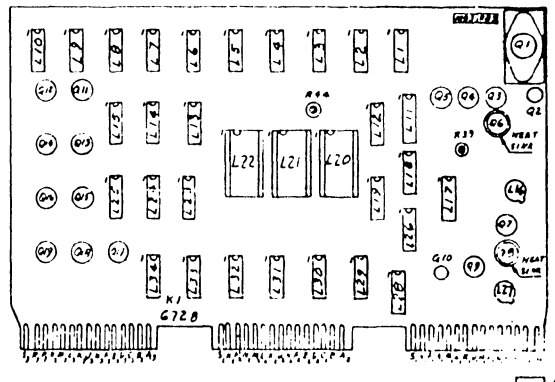

WANG

MODEL NO. 72

REGULATOR & MEMORY

210-6728 E 6728

7 6 5 4 DO NOT SCALE 3 2 1

HOLE LEGEND		
	HOLE DIA.	TOL.
DRILLED OR PUNCHED HOLE	.0135 to .125	+ .001
TOLERANCES:	.126 to .250	+ .001
	.251 to .500	+ .001

IDENT.	DESCRIPTION	QTY.
A		

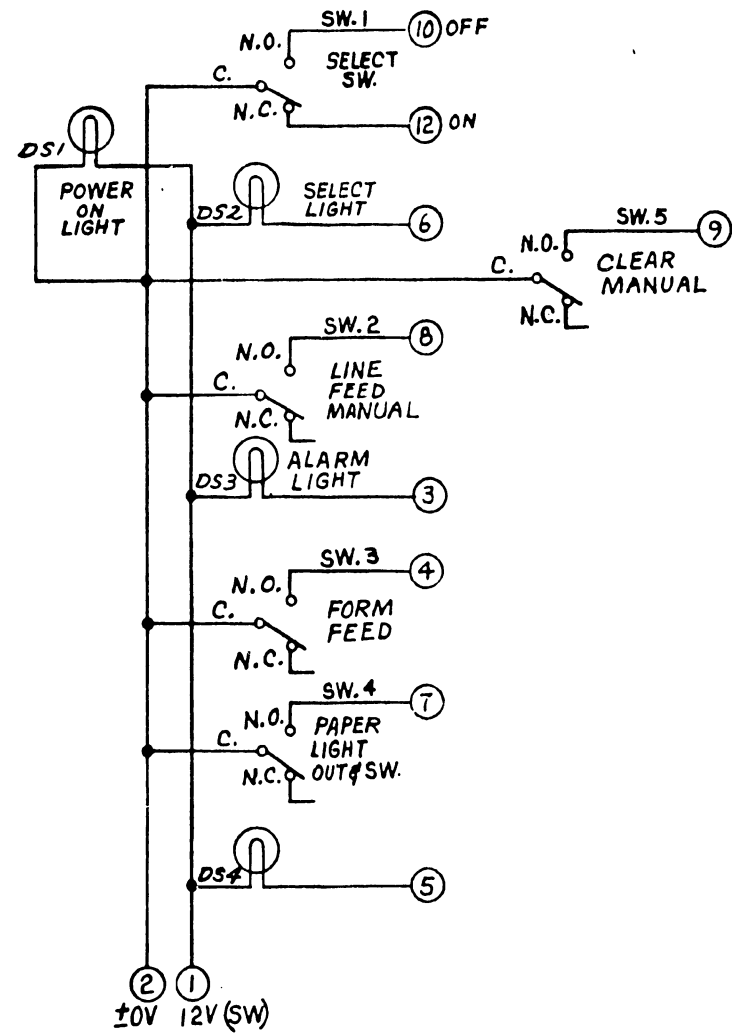

COMPONENT	W.L. PART NO.
SW.1 - SW.5	325-2305
DS1 - DS4	370-0015

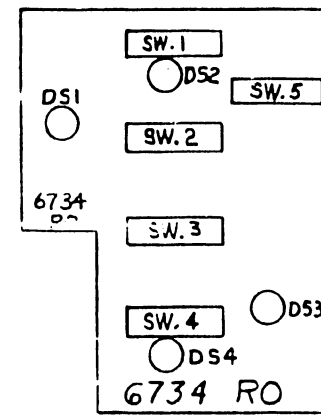

COMPONENT LAYOUT

E REV
0

REV.	DATE	BY	DESCRIPTION
1	5-15-73	G.D.	ORIG. FFR
2	5/16/75		W.C. 404
3			APP'D: <i>clm</i>
4			REL. TO PROD.
5			APP'D: <i>clm</i>

QTY. PER UNIT	WANG PART NO.	ITEM	QTY.	NAME	MATERIAL	DESCRIPTION
				WANG LABORATORIES, INC. NEWBURY MASS U.S.A.		
				MODEL NO. 72		TITLE SCHEMATIC LOGIBLOC MATRIX PRINTER
				FINISH TOL EX AS NOTED XX = 010 FRAC ± 1/64 XXX = 005 ANG ± 1'30" FINISH		
				SCALE	SMT OF	WANG PART NUMBER
						SIZE
						DRAWING NUMBER
						REV

THIS DOCUMENT IS THE PROPERTY OF WANG LABORATORIES, INC. AND SHALL NOT BE REPRODUCED OR USED AS A BASIS FOR THE MANUFACTURE OR SALE OF APPARATUS OR DEVICES WITHOUT PERMISSION.

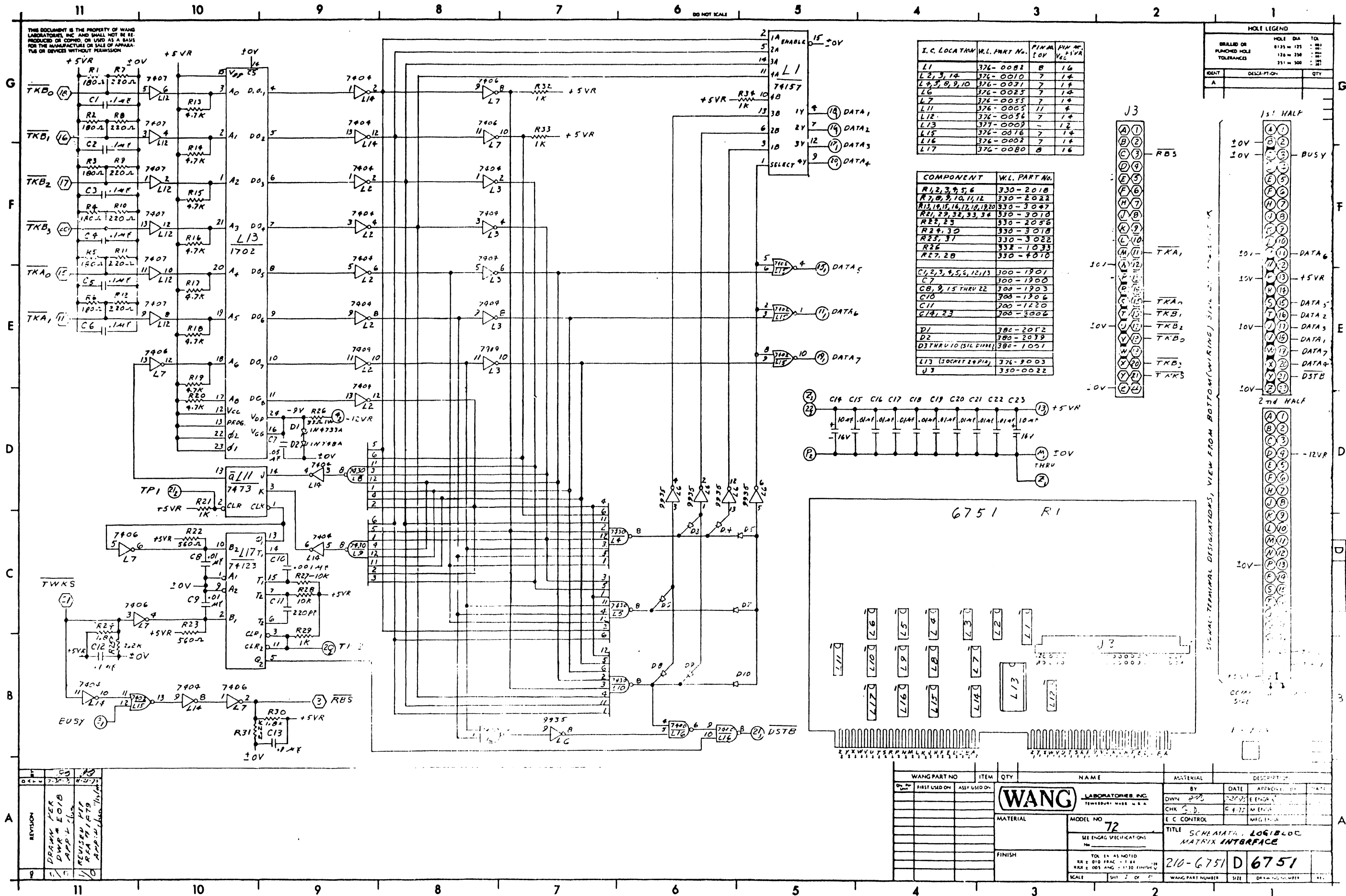

I.C. LOCATION	W.L. PART NO.	PIN A	PIN VCC
L1	376-0082	B	16
L2, 3, 14	376-0010	7	14
L4, 5, 8, 9, 10	376-0031	7	14
L6	376-0025	7	14
L7	376-0055	7	14
L11	376-0036	7	14
L12	376-0036	7	14
L13	377-0009	-	14
L15	376-0016	7	14
L16	376-0002	7	14
L17	376-0080	B	16

COMPONENT	W.L. PART NO.
R1, 2, 3, 4, 5, 6	330-2018
R7, 8, 9, 10, 11, 12	330-2022
R13, 14, 15, 16, 17, 18, 19, 20	330-3047
R21, 22, 23, 24, 25, 26	330-3010
R27, 28	330-2056
R29, 30	330-3018
R31, 32	330-3022
R33	332-1033
R34	330-4010
C1, 2, 3, 4, 5, 6, 12, 13	300-1901
C7	300-1900
C8, 9, 15 THRU 22	300-1903
C10	300-1906
C11	700-1220
C14, 23	700-3006
D1	78C-2052
D2	780-2039
D3 THRU 10 (SIL PIN)	380-1001
L13 (SOCKET 24 PIN)	376-9003
J3	350-0022

HOLE LEGEND	HOLE DIA	TOL
DRILLED OR PUNCHED HOLE	0.125 - 0.125	±0.001
TOLERANCES	128 - 250	±0.001
	251 - 500	±0.001

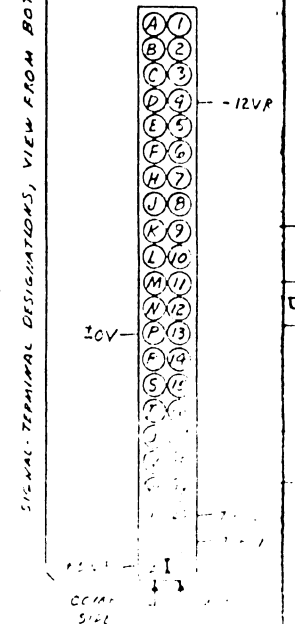
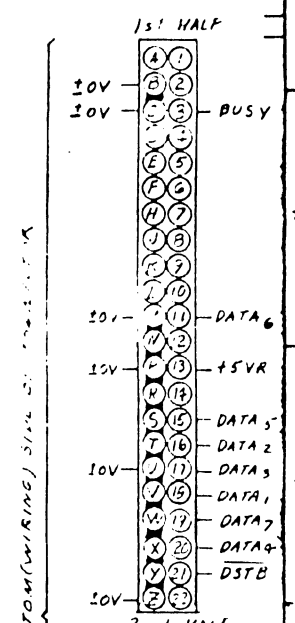

WANG PART NO.	ITEM	QTY	NAME	MATERIAL	DESCRIPTION
72	SCHEMATIC	1	SCHEMATIC, LOGIC LOC MATRIX INTERFACE		
210-6751	D	1	6751		

REVISION	DATE	BY	DESCRIPTION
1	7-23-72	W.D.	DRG FOR EOB
2	7-23-72	W.D.	APP L
3	7-23-72	W.D.	REVISED FOR RCA PARTS
4	7-23-72	W.D.	APP L

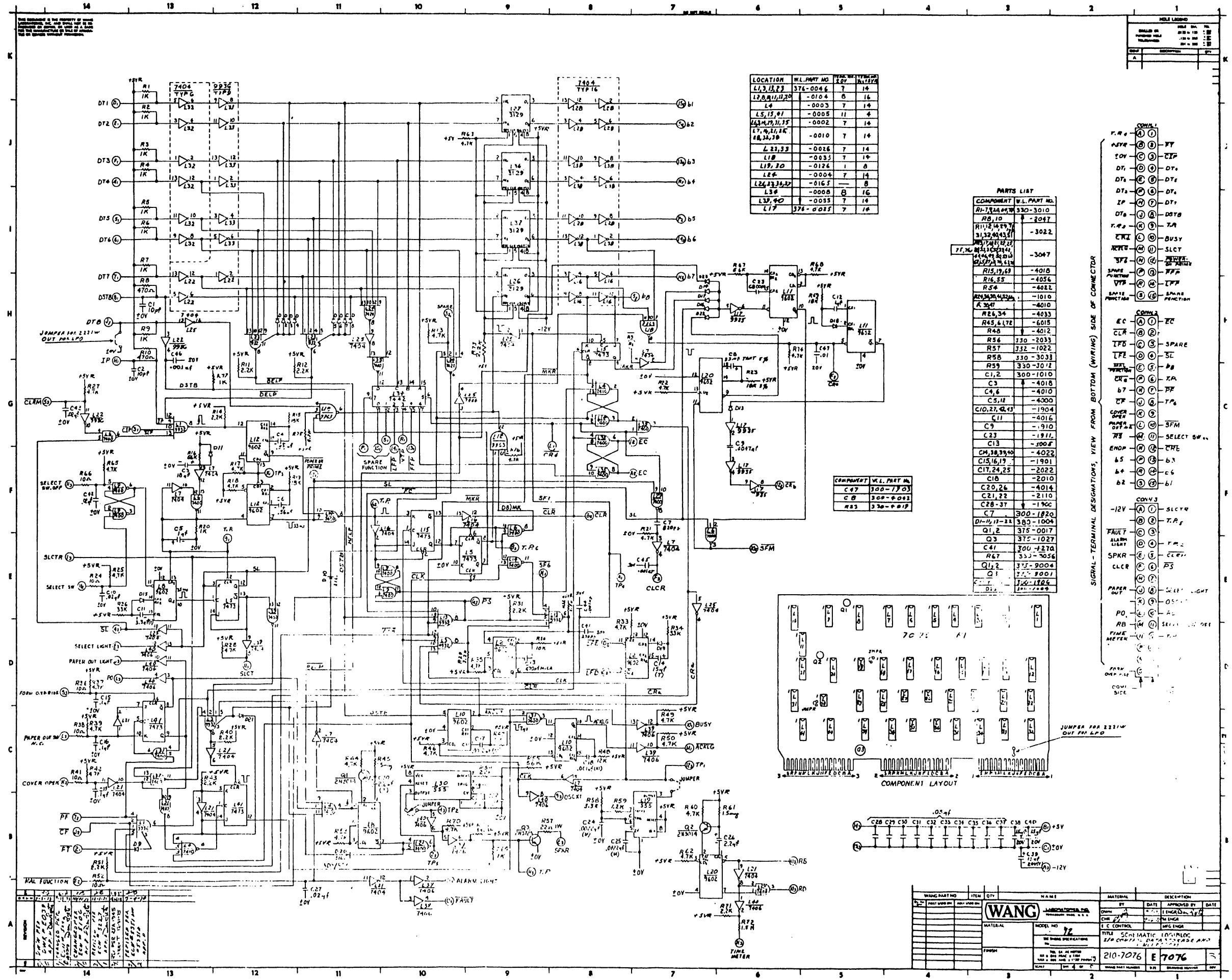

LOCATION	W.L. PART NO.	TYPE	QTY
L1,3,13,23	376-0046	7	14
L2,8,11,11,20	-0104	6	16
L4	-0003	7	14
L5,15,41	-0005	11	4
L6,17,11,35	-0002	7	14
L7,4,11,16,18,24,30	-0010	7	14
L23,33	-0016	7	14
L18	-0033	7	14
L19,30	-0124	1	6
L24	-0004	7	14
L24,23,34,37	-0165	1	6
L34	-0000	8	16
L37,40	-0035	7	14
L17	376-0085	7	14

COMPONENT	W.L. PART NO.
R1,7,14,47,70	330-3010
R2,10	-2047
R11,12,47,70	330-3010
R13,20,43,51	-3022
R14,17,22	-3067
R15,17,68	-4018
R16,55	-4056
R54	-4022
R55,61,62,63	-1010
R56	-4010
R65,34	-4033
R45,6,17,8	-6015
R48	-4012
R56	330-2033
R57	332-1022
R58	330-3033
R59	330-3012
C1,2	300-1010
C3	-4018
C4,6	-4010
C5,12	-4000
C10,27,42,43	-1904
C11	-4016
C9	-910
C23	-1911
C13	-3008
C14,38,39,40	-4022
C15,16,17	-1901
C17,24,25	-2022
C18	-2010
C20,26	-4014
C21,22	-2110
C28-37	-1900
C7	300-1820
D1-14,15-21	383-1004
Q1,2	375-0017
Q3	375-1027
C41	300-1270
R47	333-3056
Q1,2	375-3004
Q1	375-3001
D1	300-1820
D1	300-1820

COMPONENT	W.L. PART NO.
C47	300-7703
C8	300-9003
R33	330-9011

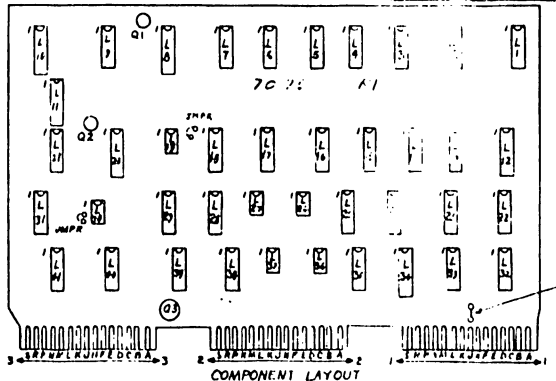

SIGNAL - TERMINAL DESIGNATIONS, VIEW FROM BOTTOM (WIRING SIDE OF CONNECTOR)
CONV.1
FF
CTP
DT1
DT2
DT3
DT4
DT5
DT6
DT7
DT8
DT9
DT10
DT11
DT12
DT13
DT14
DT15
DT16
DT17
DT18
DT19
DT20
DT21
DT22
DT23
DT24
DT25
DT26
DT27
DT28
DT29
DT30
DT31
DT32
DT33
DT34
DT35
DT36
DT37
DT38
DT39
DT40
DT41
DT42
DT43
DT44
DT45
DT46
DT47
DT48
DT49
DT50
DT51
DT52
DT53
DT54
DT55
DT56
DT57
DT58
DT59
DT60
DT61
DT62
DT63
DT64
DT65
DT66
DT67
DT68
DT69
DT70
DT71
DT72
DT73
DT74
DT75
DT76
DT77
DT78
DT79
DT80
DT81
DT82
DT83
DT84
DT85
DT86
DT87
DT88
DT89
DT90
DT91
DT92
DT93
DT94
DT95
DT96
DT97
DT98
DT99
DT100

WANG PART NO.	ITEM	QTY	NAME	MATERIAL	DESCRIPTION
210-7076	1	1	SCHEMATIC LOGS/LOC		
210-7076	2	1	SCHEMATIC LOGS/LOC		
210-7076	3	1	SCHEMATIC LOGS/LOC		
210-7076	4	1	SCHEMATIC LOGS/LOC		
210-7076	5	1	SCHEMATIC LOGS/LOC		
210-7076	6	1	SCHEMATIC LOGS/LOC		
210-7076	7	1	SCHEMATIC LOGS/LOC		
210-7076	8	1	SCHEMATIC LOGS/LOC		
210-7076	9	1	SCHEMATIC LOGS/LOC		
210-7076	10	1	SCHEMATIC LOGS/LOC		
210-7076	11	1	SCHEMATIC LOGS/LOC		
210-7076	12	1	SCHEMATIC LOGS/LOC		
210-7076	13	1	SCHEMATIC LOGS/LOC		
210-7076	14	1	SCHEMATIC LOGS/LOC		

SIGNAL	6576	6577	6728	J1	2	3	4	5	6	7	8	9	10	11	12	J13	MICRO. SMT.	SOLDER PTS.
ACKLG	M ₁					5							1	4				
Alarm Light	D ₃								5						22			
AY		S ₁		14														
AY		13 ₁		7														
b ₁						8							2	3				
b ₂	15 ₂		15 ₂															
b ₃	S ₂		S ₂															
b ₄	13 ₂		13 ₂															
b ₅	R ₂		R ₂															
b ₆	P ₂		P ₂															
b ₇	14 ₂		14 ₂															
b ₈	H ₂		H ₂															
b ₉	S ₂		S ₂															
BUSY	10 ₁																	
BY		15 ₁		11											3			
BY		14 ₁		9														
C							6						3	2				
CF	J ₂	S ₃																
CFM		H ₂																
CFP	3 ₁	K ₂																NC
CLCR	F ₃	10 ₃																
CLR	B ₂		2 ₂															
CLRH	5 ₃								6									
Collector MJ2500																		
Common						7												
Cover Open	K ₂																	
CRB	12 ₂	C ₂							1									
CRD	L ₁	11 ₃																
CRc	F ₂		3 ₂															
d:																		
DE		15 ₃				4												
Data ₁	D ₁																	
Data ₂	E ₁																	
Data ₃	F ₁																	
Data ₄	4 ₁																	
Data ₅	5 ₁																	
Data ₆	6 ₁																	
Data ₇	7 ₁																	
Data ₈	J ₁																	
DBTB	8 ₁																	
EC	A ₂		1 ₂															
EC	1 ₂		A ₂															
FAULT	C ₃																	
FFD+		N ₁			11													
FFM		M ₂																
FFP	13 ₁	H ₃						7										
FFPE		P ₁																
Form Override	S ₃																	
FI	2 ₁	F ₃							8									
IP	H ₁																	
LFD	C ₂	K ₃																
LFE	D ₂	S ₂																
LFM		P ₂																
LFP	14 ₁	J ₃							2									
Malfunction	E ₂																	
MD		F ₁																

SIGNAL RUN LIST - SHEET 1

SIGNAL	6576	6577	6728	J1	2	3	4	5	6	7	8	9	10	11	12	J13	MICRO. SWT.	SOLDER PTS.
MOB-		6 ₂		5														
MOB+		2 ₂		1														
MS ₁		9 ₁						1										
MS ₂		10 ₁			7													
OSCXT	9 ₃																	
Paper Out	L ₂				8													H
Paper Out	J ₃								7									
PE		N ₃									N	7						
PED+		11 ₁							10									
PEPE		N ₁			2													
PF	7 ₂	E ₃																
PFB		A ₂		2														
PO	L ₃																	9
Power On Prime	12 ₁	R ₂																
PS	6 ₃	9 ₃																
RB	M ₃	C ₃																
RD	10 ₃	M ₃																
RS	M ₂	D ₃																
RS ₁		K ₁			5													
RS ₂		J ₁						4										
RT ₁		8 ₁			3													
RT ₂		H ₁						6										
RTH	N ₃																	
S ₁			K ₃									9						
S ₂			11 ₃									4						
S ₃			6 ₃									3						
S ₄			M ₃									12						
S ₅			12 ₃									2						
S ₆			J ₃									1						
S ₇			9 ₃									6						
S ₈			8 ₃									8						
S ₉			N ₃									10						
S1C											A			K			9	
S2C											B			J			7	
S3C											C			H			5	
S4C											D			F			16	
S5C											E			E			14	
S6C											F			D			12	
S7C											H			C			10	
S8C											J			B			8	
S9C											K			A			6	
S1R										7								
S2R										9								
S3R										5								
S4R										3								
S5R										1								
S6R										10								
S7R										8								
S8R										6								
S9R										4								

SIGNAL RUN LIST - SHEET 2

SIGNAL	6576	6577	6728	J1	2	3	4	5	6	7	8	9	10	11	12	J13	MICRO. SWT.	SOLDER PTS.		
Select SW On	11 ₂								4											
Select SW Off	11 ₃								11											
Select Light	8 ₃								9											
SFG	N ₁		B ₂																	
SFM	10 ₂	A ₃	B ₃																	
SE	4 ₂	B ₃																		
SLCT	11 ₁													F						
SLCTR	1 ₃	8 ₃																		
SPKR	E ₃																	*		
SW ₀		H ₂						8												
SW ₁		J ₂						3												
SW ₂		L ₂						5												
TACH-		4 ₁					2													
TACH+(+OV)		3 ₁					4													
VR-5B			7 ₁	10																
BR-12B			15 ₁	12																
VTD+		12 ₁			9															
VTP	R ₁	D ₂																		
VTPE		R ₁			6															
WS		L ₃	L ₃																	
+0	C ₁	12 ₃	3 ₁		10		1		12		11		10	11			ACM	P	NO	*
	13 ₃	C ₁	C ₁														NPR			
	P ₃	13 ₃	P ₃														STU			
			13 ₃														VWX			
																	YZ10			
+5VR	R ₃	14 ₃	2 ₁	13	12						12						13	22		
	B ₁	B ₁	14 ₃																	
	14 ₃	R ₃	B ₁																	
			14 ₁																	
			R ₃																	
+9V			D ₁	15									L	15						*
+12VR			L ₁												6	5				*
-12VR	A ₃		13 ₁	16											2	4				*
			A ₃																	
+18V		5 ₁	5 ₁	3																*
+36V			B ₁							2										*
+9VSW			4 ₁																	
			H ₃																	
-12VSW		1 ₁	1 ₁																	
+12VSW		A ₁	A ₁						3											
			B ₂																	
24VAC(L)		7 ₁																		*
24VAC(H)								2												*
----							3													*
-24V		E ₁	E ₁	6	1															*

SIGNAL RUN LIST - SHEET 3

END