

Technical Manual No.
799800-007
Revision U

OPERATION AND MAINTENANCE INSTRUCTIONS
FOR MODEL 100X DUAL-MODE
MAGNETIC TAPE TRANSPORTS

Cipher Data Products
10225 Willow Creek Road
San Diego, California 92131

PREFACE

This manual presents the information required for operation and maintenance of the Cipher Model 100X Dual-Mode Magnetic Tape Transport. Please

read this document thoroughly before unpacking, installing, or operating the transport. The manual is divided into seven sections, as follows:

- I Description and Specifications
- II Unpacking, Inspection, and Installation
- III Operation
- IV Theory of Operation
- V Maintenance
- VI Troubleshooting
- VII Parts Lists, Schematics, and Assembly Drawings

EMBEDDED FORMATTER ADDENDUM. An addendum is included in the manual for a transport in which an embedded formatter is incorporated. Addendum F is provided for an NRZI embedded formatter, Addendum G for a PE formatter, and Addendum H for a dual-mode formatter. The model numbers for such transports are the same as those presented above, with the addition of a letter "F" prefix.

SPECIAL CONFIGURATION SUPPLEMENT. A supplement is included in the manual for any transport whose configuration incorporates a deviation from the standard models covered in the engineering documentation of the basic manual and/or addendum.

CHANGE NOTICE. A change notice is inserted in the front of the manual for any transport incorporating material engineering changes made since the printing of the manual.

TABLE OF CONTENTS

SECTION		PAGE
I	DESCRIPTION AND SPECIFICATIONS	1-1
	1-1 General	1-1
	1-3 Purpose	1-1
	1-5 Physical Description	1-1
	1-8 Tape Drive	1-1
	1-12 Functional Description	1-3
	1-22 Mechanical and Electrical Specifications	1-5
	1-24 Interface Specifications	1-6
II	UNPACKING, INSPECTION, AND INSTALLATION	2-1
	2-1 General	2-1
	2-3 Unpacking and Inspection	2-1
	2-5 Power Connection	2-1
	2-7 Initial Checkout	2-2
	2-9 Rack Mounting	2-3
	2-11 Interface Connections	2-4
III	OPERATION	3-1
	3-1 General	3-1
	3-3 Controls and Indicators	3-1
	3-5 Loading Tape	3-1
	3-7 Unloading Tape	3-1
	3-9 Interface Data	3-2
	3-11 Multiple-Transport (Daisy-Chain) System Modification	3-2
IV	THEORY OF OPERATION	4-1
	4-1 General	4-1
	4-3 Basic Concepts of Digital Recording	4-1
	4-5 Data Recording/Reading With Magnetic Tape	4-1
	4-8 Major Transport Components	4-1
	4-12 NRZI Coding System	4-1
	4-20 Phase-Encode System	4-6
	4-26 Dual-Mode PWB Theory	4-7
	4-65 Control Logic State Decoder	4-14
	4-87 Command Logic	4-18
	4-91 Forward Command Circuit	4-18
	4-108 Reel Servos	4-26

TABLE OF CONTENTS (Continued)

SECTION		PAGE
4-118	Write Protect Circuit	4-30
4-121	Logic Options	4-30
4-125	Power Supply	4-32
V	MAINTENANCE	5-1
5-1	General	5-1
5-3	Cleaning	5-1
5-8	Removal, Replacement, and Mechanical Adjustments	5-2
5-19	Power Supply Checks and Adjustments	5-5
5-22	Tape Sensor Adjustment	5-6
5-25	Compliance Arm Adjustments	5-6
5-27	Capstan Servo Adjustments	5-6
5-33	Data PWB Initial Switch Settings	5-11
5-36	Read Gain Adjustments	5-11
5-42	Mechanical Adjustments	5-14
5-47	Replacement of Assemblies	5-17
5-50	Removal and Replacement of Parts and Components	5-17
5-52	Programming Write Deskew PROM	5-19
VI	TROUBLESHOOTING	6-1
6-1	General	6-1
6-3	Troubleshooting	6-1
VII	PARTS LIST, SCHEMATICS, AND ASSEMBLY DRAWINGS	7-1
7-1	General	7-1

LIST OF ILLUSTRATIONS

FIGURE		PAGE
1-1	Model 100X Transport	1-2
1-2	System Block Diagram	1-4
1-3	Interface Configuration	1-6
2-1	Model 100X Outline Dimensions	2-5
2-2	Rack Mounting and Dimensions	2-7
2-3	Installation Diagram	2-9
2-4	Interface Cable Installation	2-13
3-1	Control Panel	3-2
3-2	Tape-Threading Path	3-5
3-3	Operating Configuration (Tape Tensioned)	3-6
4-1	Magnetic Recording Waveforms	4-2
4-2	Phase-Encode Tape Magnetization	4-3
4-3	Transport Organization	4-4
4-4	Nine-Track Data Format	4-6
4-5	Phase-Encoded Tape Block Format	4-8
4-6	Write Data Block Diagram	4-10
4-7	Read Data Block Diagram	4-12
4-8	State Decoder	4-15
4-9	Load Sequence Flow Chart	4-16
4-10	Local/Remote Operation Flow Chart	4-19
4-11	Forward Command Logic Block Diagram	4-21
4-12	Capstan Driver Flow Diagram	4-23
4-13	Reel Servo Block Diagram	4-27
4-14	Compliance Arm Motion Sensor Assembly and Limit Switch	4-28
4-15	Retractor Flow Chart	4-29
4-16	Retractor Motor Timing Diagram	4-30
5-1	Single-Edge Tape Guide	5-3
5-2	Reel Hub, Showing Adjustment Dimension	5-4
5-3	Head Assembly Adjustments	5-5
5-4	Control/Servo Board Test Point Chart	5-7
5-5	Test Points and Adjustment Potentiometers, Dual-Mode PWB	5-10
5-6	Strobe Disc	5-11
5-7	Ramp Adjustment Traces	5-11
5-8	Skew Pulse at TP10	5-13
5-9	Tape Path and Related Parts	5-15
5-10	Reel Hub Assembly	5-16
5-11	Control/Servo Board Removal	5-18
7-1	Integrated Circuit Data and Connections	7-1

LIST OF TABLES

TABLE		PAGE
1-1	Mechanical and Electrical Specifications	1-5
2-1	Power Connections	2-2
2-2	Interface Connections	2-11
3-1	Controls and Indicators	3-3
3-2	Interface Inputs	3-7
3-3	Interface Outputs	3-8
4-1	Head Specifications	4-5
4-2	Control/Servo Board Logic Options	4-31
5-1	Preventive Maintenance Schedule	5-2
5-2	Power Supply Unregulated Voltages	5-6
5-3	Power Supply Regulated Voltage Adjustments	5-6
5-4	Capstan Servo Adjustment Parameters	5-9
5-5	Tape Speed Crystal Frequencies and Switch/Settings	5-11
5-6	Switch Settings for Testing & Options	5-12
5-7	Bit Map, Code 23456789	5-20
5-8	Bit Map, Code 77777777	5-20
5-9	Bit Map, Code 6789A987	5-20
6-1	Common Problems	6-2
6-2	System Troubleshooting	6-3

SECTION 1

DESCRIPTION AND SPECIFICATIONS

1-1. GENERAL

1-2. The Model 100X Dual-Mode Magnetic Tape Transport is a high-performance, digital tape transport manufactured by Cipher Data Products, Inc., San Diego, California. This transport is capable of recording and writing either NRZI or phase-encoded PE digital data. It is equipped with a dual-gap head, which provides nine-track read-after-write capability, and various tape speed capabilities are available. The transport will accommodate reels up to 10.5 inches in diameter and is designed to operate on 105 to 250-Vac, single-phase, 48 to 63-Hz line power. If the compliance arm retraction feature is not required, the transport may be operated on line power frequencies up to 400 Hz. Available optional features are as follows:

- a. Overwrite
- b. Tape speeds:
 - (1) Standard: 45, 37.5, 25, 18.75, or 12.5 ips
 - (2) Nonstandard: any fixed speed within the range of 2 to 75 ips
- c. Local density selection
- d. Remote density selection
- e. Power: 400-Hz operation (without compliance arm retraction system)
- f. Logic options (see paragraph 4-92)
- g. Facade color (white is standard)

1-3. PURPOSE

1-4. The transport is designed to be used in data acquisition and computer processing systems in which data must be acquired and stored on magnetic tape. Writing and reading of digital data are performed in IBM-compatible, NRZI or PE format. Data recorded by a Model 100X transport is completely recoverable by IBM or similar equipment.

1-5. PHYSICAL DESCRIPTION

1-6. The Model 100X transport (Figure 1-1) is designed to be hinge-mounted in a standard 19-inch equipment rack. All components are mounted on a precision-ground, cast-aluminum plate. When the equipment rack is securely anchored, the printed circuit boards and other internal components can be made accessible from the front by releasing the adjustable pawl fastener and swinging the transport open on its hinges. A transparent, hinged, front cover protects the transport from dust and other foreign matter while allowing observation of tape motion. The pushbutton controls, which illuminate when the commanded sequence is complete, are mounted on the front trim panel, where they are accessible with the cover closed. The power connector is a standard, three-pin, grounded plug.

1-7. Four printed-wiring boards (PWBs) are used in the Model 100X dual-mode transport: a dual-mode data board, a control/servo board, and a power board, all mounted on the rear of the mounting plate; and an EOT/BOT detector board mounted on the front of the unit, under the head cover.

1-8. TAPE DRIVE

1-9. The reel-to-reel drive employs two servo-controlled, direct-drive, dc torque motors to drive the tape reels. The reels are secured to their hubs by lever-actuated expanding rings. Two spring-loaded compliance arms maintain tape tension at 8 ounces and serve as tape-storage buffers. A compliance arm retractor system, energized when power is turned on, drives the compliance arms to their full-up positions for ease of tape threading. During the load sequence the compliance arms are returned to their operating positions to perform buffering and tensioning functions.

1-10. The tape path includes both roller and fixed guides, the head, cross-feed shield, and a tape cleaner. The roller guides utilize precision bearings to minimize friction and reduce wear, and the

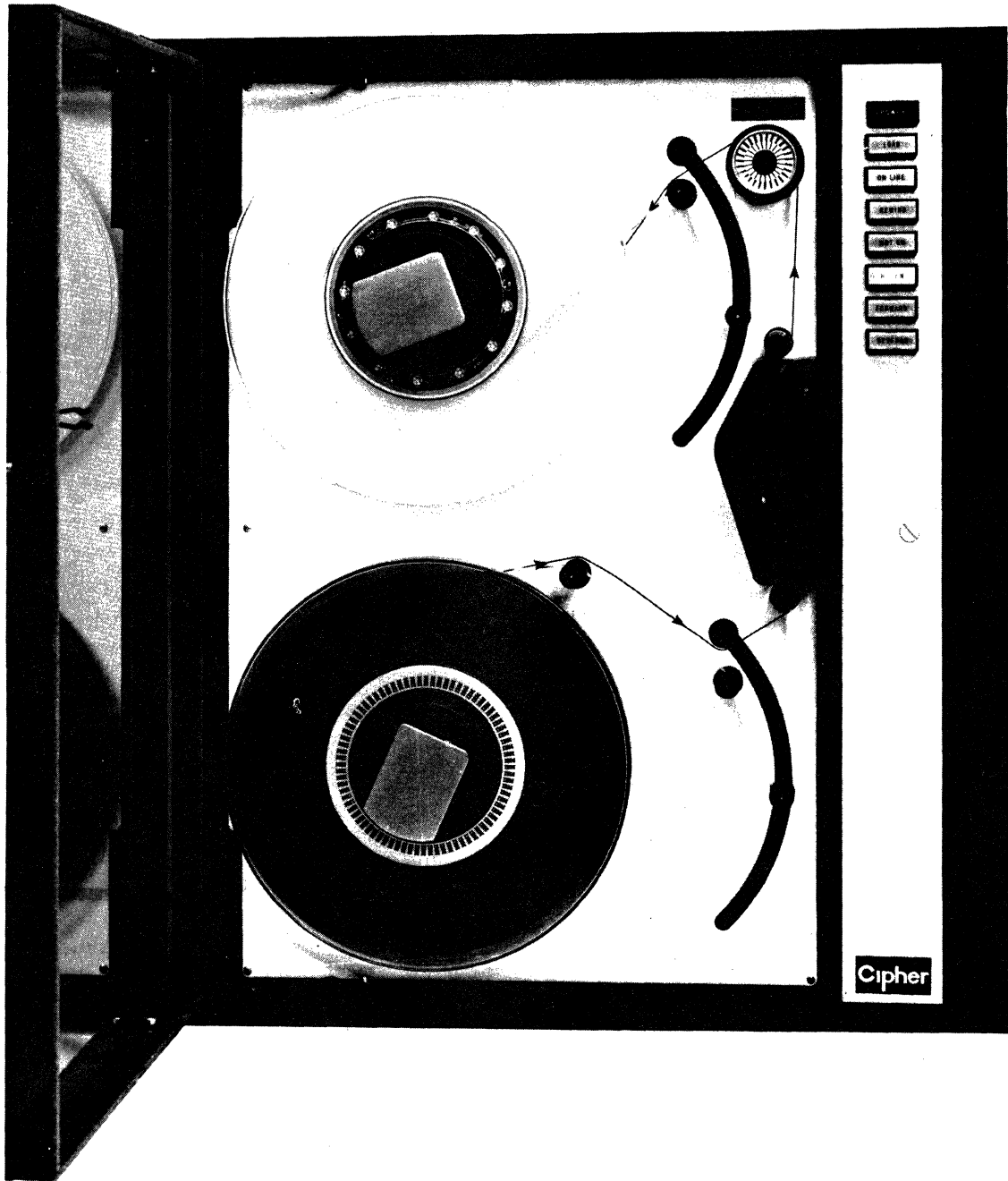

Figure 1-1. Model 100X Transport (Sheet 1)

wearing surfaces of the fixed guides are hard-chrome plated. The fixed guides, on each side of the head, are of the single-edge type. The outer (reference) flange of each guide is fixed to an exact dimension, and the bottom flange is spring loaded to force the tape against the reference edge at all times. This arrangement provides minimum skew and minimizes the effect of tape width variations. In addition, the head and cross-feed shield are mounted on an adjustable plate which provides for precise azimuth alignment.

1-11. A tape scraper is mounted under the head cover just ahead of the EOT/BOT reflector. Its purpose is to minimize tape contamination. The sharp-edged blades of the scraper are of nonmagnetic, long-wearing sapphire.

1-12. FUNCTIONAL DESCRIPTION

1-13. Figure 1-2 is a system block diagram. A 180-degree-wrap capstan drive is used for controlling tape movement during write, read, and rewind operations. The capstan is controlled by a velocity servo. The velocity information is generated by a dc tachometer that is coupled directly to the capstan motor shaft and produces a voltage proportional to the angular velocity of the capstan. This voltage is compared to the reference voltage from the ramp generator by means of operational amplifier techniques, and the difference is used to control the capstan motor. This capstan control technique gives precise control of tape accelerations and tape velocities, thus minimizing tape tension transients.

1-14. During a write operation, the tape is accelerated in a controlled manner to the required velocity. This velocity is maintained constant, and data characters are written on the tape at a constant rate. Thus, the following relationship exists:

$$\text{Bit density} = \frac{\text{Character Rate}}{\text{Tape Velocity}}$$

1-15. When data recording is complete, the tape is decelerated to zero velocity in a controlled manner. Since the write operation demands a constant tape velocity, inter-record gaps (IRG) must be provided to allow for the tape acceleration and deceleration periods. Control of tape motion to produce a defined IRG is provided externally by the customer controller, in conjunction with the tape acceleration and deceleration characteristics defined by the transport specifications.

1-16. An optional overwrite feature provides for editing of previously recorded data. The Overwrite signal causes Write Enable to ramp on and off, minimizing the change in inter-record gap magne-

tism in rewriting a record. Write Amplifier Reset, used with the overwrite option, causes both write head current and erase head current to be turned off immediately after writing of the new record to prevent destruction of data in the following record.

1-17. During a read operation, the tape is accelerated to the required velocity in a time interval sufficiently short to allow tape velocity to become constant before data signals are received. Nine data channels are presented to the interface. The end of a record is detected in the external controller by means of gap-detection circuits, and the tape is commanded to decelerate in a controlled manner. The transport can operate in the read mode in either the forward or reverse direction. When operating in a shuttling mode (e.g., synchronous forward, stop, synchronous reverse, and stop) no turnaround delay is required between the end of one motion command and the beginning of the next motion command in the opposite direction. For assurance of IBM-compatible tapes, with fully saturated gaps and precise dimensions, tape motion must be allowed to cease before switching of the motion control lines and Write Enable line.

1-18. In addition to the capstan control system, the transport incorporates supply and takeup reel servo systems, a compliance arm system, a magnetic head and associated read/write electronics, and the control logic.

1-19. The compliance arms compensate for differences in the tape speed arising out of the relatively fast starts and stops of the capstan and those of the slower, high-inertia supply and takeup reels. When the rate of tape travel at the capstan differs from that at which the reels are supplying or taking up the tape, the supply and/or takeup reel compliance arms move to compensate for this difference. At the same time, a photoelectric sensor measures the resulting displacement of each arm and feeds an error signal to the respective reel motor servo. This signal is amplified and is used to control the reel motor, increasing or decreasing its speed as necessary to compensate for the momentary difference in tape speed and bring the compliance arm back to its nominal operating position. The compliance arm system is designed to provide a constant tape tension of 8 ounces, as long as the arms are within their operating regions. Tape spillage is prevented, in the event power is lost, by a self-braking feature designed into the servo circuitry. When power is lost the takeup reel motor terminals are connected together through a current-limiting resistor, and the supply reel motor terminals are directly connected, producing a dynamic braking action.

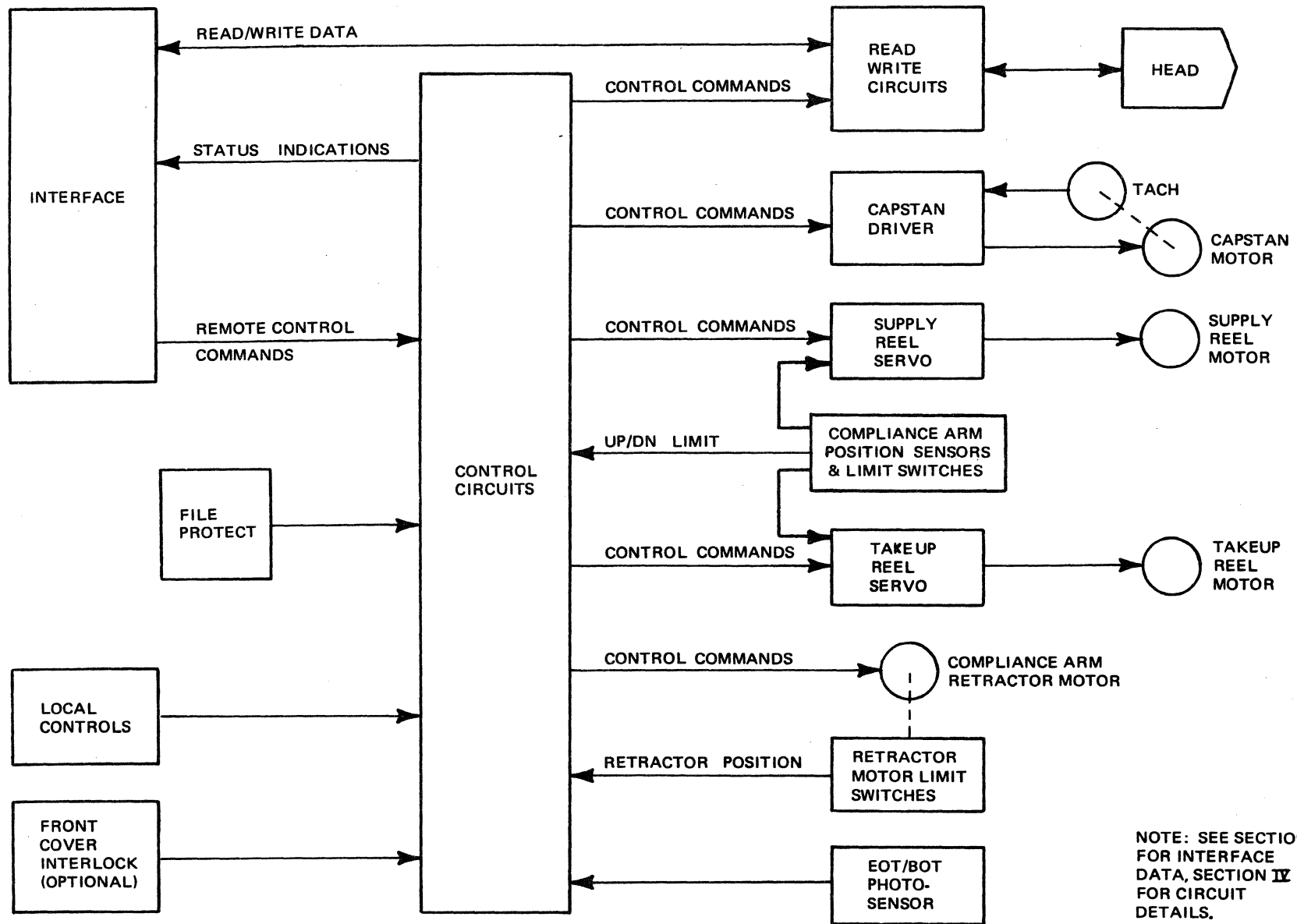

NOTE: SEE SECTION II FOR INTERFACE DATA, SECTION IV FOR CIRCUIT DETAILS.

Figure 1-2. System Block Diagram

1-20. The magnetic head, under control of the read/write electronics, writes and reads the flux transitions on the tape. The read function is operating continuously, while the write function must be enabled in order to operate. An erase head provides continuous dc erasure across the full width of the tape during write operations.

1-21. The control logic operates on manual commands to enable tape, once loaded, to be brought to the load point. At this stage remote commands control tape motion, writing, and reading. The logic also provides rewind and unload functions in conjunction with the manual REWIND control. A photoelectric sensor assembly, consisting of a lamp and two phototransistors, is used to detect the beginning-of-tape (BOT) and end-of-tape (EOT) markers as well as unthreaded or broken tape. The detection area of the sensor assembly is approximately 1.2 inches from the write head gap.

1-22. MECHANICAL AND ELECTRICAL SPECIFICATIONS

1-23. The mechanical and electrical specifications for the recorder are shown in Table 1-1.

1-24. INTERFACE SPECIFICATIONS

1-25. Section II contains a table of interface connections. Signal characteristics are as follows:

- a. Levels
 - (1) True is low: 0 to 0.4 volt (approximately).
 - (2) False is high: > 2.4 volts (approximately).
- b. Pulses
 - (1) Levels as above.
 - (2) Edge transmission delay over 20 feet of cable is not greater than 200 nanoseconds.

1-26. The interface circuits are so designed that a disconnected wire results in a false signal. Figure 1-3 shows the interface configuration for which the transport is designed.

Net Weight	80 pounds (36.29 kg)
Shipping Weight	117 pounds (45.36 kg)
Dimensions:	
Height	24.0 inches (62.2 cm)
Width	19.0 inches (48.3 cm)
Depth (from mounting surface)	12.5 inches (31.8 cm)
Depth (total)	15.1 inches (38.4 cm)
Mounting (standard 19-in. RETMA rack)	EIA specifications
Power	115/230 Vac 48 to 63 Hz (400-Hz model available without compliance arm retraction system) 340 watts, max. at 45 ips
Fuse:	
105-125 Vac Models	6A, 3AB, Norm-blo, 250 Vac
210-250 Vac Models	4A, 3AG, Norm-blo, 250 Vac
Tape (computer grade):	
Width	0.5 inch (1.27 cm)
Thickness	1.5 mil (0.04 mm)
Reel Diameter	10.5 inch (26.67 cm), max.

Table 1-1. Mechanical and Electrical Specifications

Tape Tension	8 ounces (226.8 grams)
Recording Modes & Densities:	
Nine-Track, IBM-compatible PE	1600 bpi
Nine-Track, IBM-compatible NRZI	800 bpi
Tape Speed:	
Standard	45/37.5/25/18.75/12.5 ips
Nonstandard available	2 to 75 ips
Speed Variation:	
Instantaneous	± 3% (max., byte-to-byte)
Long term	± 1% (max.)
Rewind Speed	150 ips (nom.)
Start/Stop Time (inversely proportional to tape speed)	8.33 (± 0.55) ms at 45 ips
Start/Stop Distance	0.19 (± 0.02) inch (0.48 (± 0.05) cm)
Interchannel Displacement Error	150 microinches (0.004 mm), max.
Beginning-of-Tape (BOT) and End-of-Tape (EOT) Detectors	Photoelectric (IBM-compatible)
Interface	TTL-Compatible (Low True)
Electronics	All Silicon
Operating Temperature	2° to 50°C
Relative Humidity	15 to 95%, noncondensing
Altitude	20,000 feet (6096 meters) max.

Table 1-1. Mechanical and Electrical Specifications (Continued)

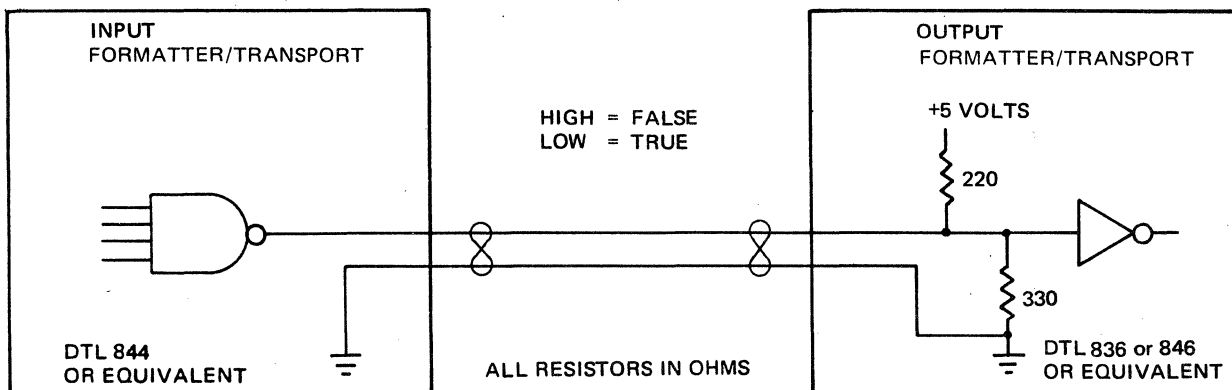

Figure 1-3. Interface Configuration

SECTION II

UNPACKING, INSPECTION, AND INSTALLATION

2-1. GENERAL

2-2. This section presents instructions for unpacking, inspecting, and installing the transport.

2-3. UNPACKING AND INSPECTION

2-4. The transport is shipped in a double container to minimize the possibility of damage during shipping. Unpack as follows:

- a. With shipping container on floor or work bench, cut side and center tapes securing top of outer box.
- b. Pull box-top flaps down along sides of box, and turn entire package over on open side of outer box. Lift off outer box and remove packing blocks.



Do not cut center tape of inner box without first cutting side tapes and pulling flaps away from top of container. Plastic door of transport can be damaged by failure to observe this precaution.

- c. Cut side tapes securing top of inner box, pull flaps up as far as possible, and cut center tape. Open box, fold flaps back, turn over on open side, and lift off box.
- d. Check contents of shipping container against packing slip, and inspect for possible damage. **IF DAMAGE EXISTS, NOTIFY CARRIER.**
- e. Examine compliance arms, reel hubs, capstan, and other components in tape path for foreign matter.

- f. Check printed circuit boards and all connectors for correct installation. Check that plug-in relay on control/servo printed circuit board is securely in place.
- g. Check that identification label on back of transport bears correct model number and line voltage requirement. If actual line voltage at installation differs from that on identification label, change power transformer connections (paragraph 2-6). Retractor motor and power indicator wires should remain on 115-volt terminals.

2.5 POWER CONNECTION

2-6. A fixed, strain-relieved power cord is supplied for plugging into a polarized 115-volt outlet. For other power sockets, the supplied plug must be removed and the correct plug installed. If actual line voltage at installation differs from that shown on the transport identification label, change the transformer connections in accordance with Table 2-1, using the following procedure:

- a. Working from rear of transport, remove data PWB as follows:
 - (1) Disconnect cable connectors to plugs P20, P21, and P22.
 - (2) Remove and save four screws securing data PWB to four standoff hinges.
 - (3) Remove data PWB from transport.
- b. Disconnect all Fast-on connectors on transformer ends of wires from plug P19 from transformer.
- c. Disconnect all Fast-on jumpers from transformer and save.

100 VOLTS		115 VOLTS		125 VOLTS		200 VOLTS	
Wire No.	To	Wire No.	To	Wire No.	To	Wire No.	To
1	T1-5A	1	T1-5A	1	T1-5A	1	T1-5A
2	T1-3	2	T1-2	2	T1-1	2	T1-3
3	T1-7	3	T1-6	3	T1-5	3	R1-22
4	T1-4	4	T1-4	4	T1-4	4	T1-8
5	T1-8	5	T1-8	5	T1-8	5	T1-23
6	T1-4A	6	T1-4A	6	T1-4A	6	T1-4A
JUMPER		JUMPER		JUMPER		JUMPER	
T1-22	T1-23	T1-22	T1-23	T1-22	T1-23	T1-4	T1-7
215 VOLTS		230 VOLTS		240 VOLTS		250 VOLTS	
Wire No.	To	Wire No.	To	Wire No.	To	Wire No.	To
1	T1-5A	1	T1-5A	1	T1-5A	1	T1-5A
2	T1-3	2	T1-2	2	T1-2	2	T1-1
3	T1-22	3	T1-22	3	T1-22	3	T1-22
4	T1-8	4	T1-8	4	T1-8	4	T1-8
5	T1-23	5	T1-23	5	T1-23	5	T1-23
6	T1-4A	6	T1-4A	6	T1-4A	6	T1-4A
JUMPER		JUMPER		JUMPER		JUMPER	
T1-4	T1-6	T1-4	T1-6	T1-4	T1-5	T1-4	T1-5

Table 2-1. Power Connections

- d. Disconnect all Fast-on terminals without wires (blanks) and save.
- e. Referring to Table 2-1, locate listing for desired voltage, check wire label numbers, and locate them in WIRE NO. column. Connect Fast-on connector of each wire to corresponding terminal listed in TO column. Connect previously removed jumper to transformer terminals indicated under JUMPER.
- f. Connect blank Fast-on connectors to all remaining bare transformer terminals.



Bare slip-on transformer terminals carry high voltage. To protect against fatal or serious injury, ensure that all unused terminals are covered with blank Fast-on connectors, as in step f.



Ensure that all wires are routed so as not to interfere with compliance arm transducers.

- g. Replace data board in reverse procedure of that presented in step a, paragraph 1.
- h. Install fuse required for voltage, as follows: 100 to 125V (60Hz), Fuse Part No. 211151-225, 6A, N.B., 250V; 200 to 250V (60Hz), Fuse Part No. 211151-222, 3A, N.B., 250V; 200 to 250V (50Hz), Fuse Part No. 211151-223, 4A, N.B., 250V.

2-7. INITIAL CHECKOUT

2-8. Section III contains a detailed description of all controls. To check for proper transport

operation before placing in the system, proceed as follows:

- a. Connect power cord. (Replace power plug and change power transformer primary connections if necessary).
- b. Clean tape path as directed under paragraph 5-3.
- c. Load tape in accordance with instructions in paragraph 3-5.
- d. Turn power on by depressing POWER control.
- e. Momentarily depress LOAD control to apply capstan-motor and reel-motor power. Delay at this point is required to allow arm retractor mechanism to clear compliance arms.
- f. Momentarily depress LOAD control a second time to initiate load sequence. Tape will move forward until it reaches BOT tab. LOAD indicator should illuminate when BOT tab reaches photosensor and remain illuminated until tape moves off load point. At this point there will be no action when LOAD control is depressed.
- g. Check ON LINE pushbutton by depressing repeatedly and observing that ON LINE indicator is alternately illuminated and extinguished.
- h. With transport off line (ON LINE indicator not illuminated), press alternate-action FORWARD control. Run several feet of tape onto takeup reel, and press FORWARD control again to stop tape.
- i. Press alternate-action REVERSE switch. Tape will move backward until BOT tab reaches photosensor, when it will stop.
- j. Using FORWARD control, run several feet of tape onto takeup reel. Depress FORWARD control again to stop tape. Depress REWIND control momentarily to initiate rewind mode and light REWIND indicator. Tape will rewind past

BOT tab, enter load sequence, return to BOT tab, and stop with LOAD indicator illuminated. If REWIND control is momentarily depressed when tape is at BOT, LOAD indicator will be extinguished, REWIND indicator will be illuminated, and tape will rewind until tape tension is lost. This action is used to unload tape (paragraph 3-7). Reel can then be removed.

- k. Check components of tape path visually for correct tape tracking (tape riding smoothly in head, guides, etc.).

2-9. RACK MOUNTING

2-10. The transport is designed to be mounted in a standard, 19-inch-wide, RETMA equipment rack. A front panel height of 24 inches and a minimum depth of 12.5 inches behind the mounting surface are required. Note outline dimensions in Figure 2-1, and, referring to Figures 2-2 and 2-3, mount the transport as follows:

- a. Install hinge pin blocks on equipment rack using 10-32 pan head screws (Figure 2-2). Do not fully tighten screws. Place No. 10 shim washer on each pin.
- b. Set shipping frame down with front door of transport facing up (i.e., lying in horizontal position). Remove screws securing transport to frame.
- c. Lift transport out of shipping frame, position 60 degrees from closed position, and hang it on hinge pin blocks. See Figure 2-3.
- d. Adjust hinge blocks on equipment rack so that transport hangs symmetrically in rack. Tighten screws.
- e. Open transport to 90 degrees and install safety block, using 4-40 screw (Figure 2-3).
- f. Check that adjustable pawl fastener engages behind equipment rack. Adjust if necessary.
- g. Clean tape deck as directed under paragraph 5-3.

2-11. INTERFACE CONNECTIONS

2-12. Interconnection of Cipher Data Products and customer equipment requires a harness of individual twisted pairs, each with the following characteristics:

- a. Maximum length of 20 feet.
- b. Not less than one twist per inch.
- c. A 22 or 24-gauge conductor with minimum insulation thickness of 0.01 inch.

2-13. It is important that the ground side of each twisted pair be grounded within a few inches of the driver to which it is connected. The mating connectors (ELCO part number 00-6007-036-980-002 or equivalent) must be wired by the customer. As shown in Figure 2-4, interface signals are routed directly to and from the printed circuit boards. Strain relief should be provided. Table 2-2 shows the input/output lines required.

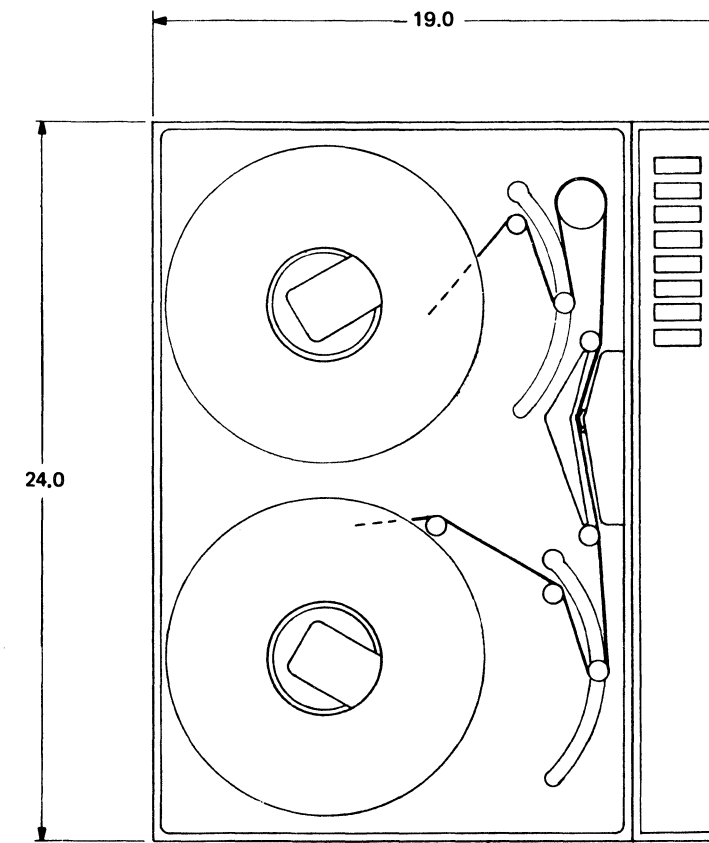
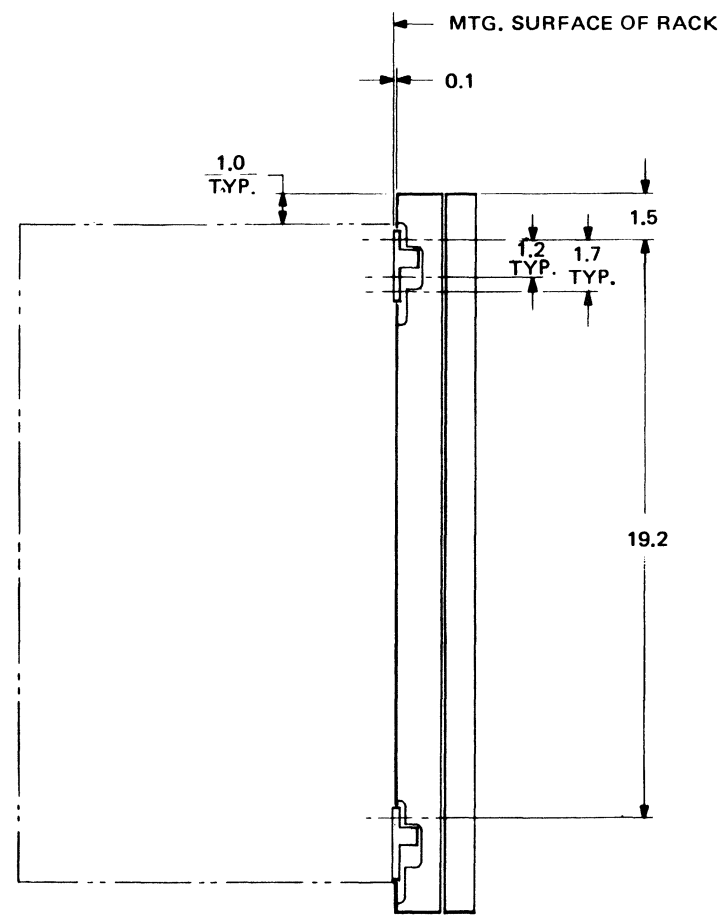
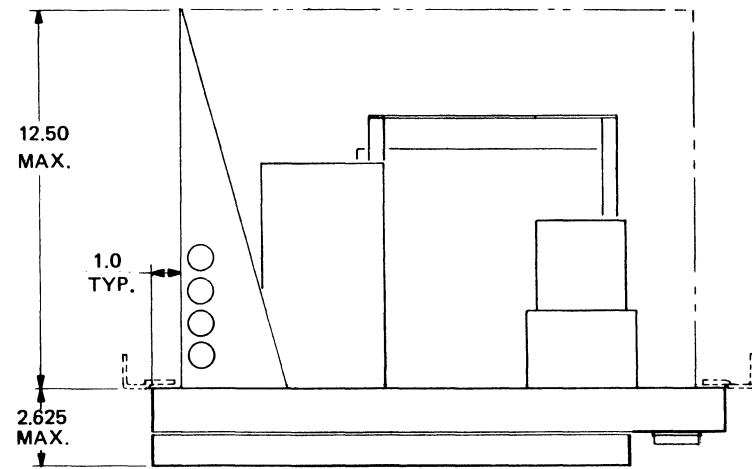

DIMENSIONS IN INCHES UNLESS OTHERWISE NOTED

Figure 2-1. Model 100X Outline Dimensions

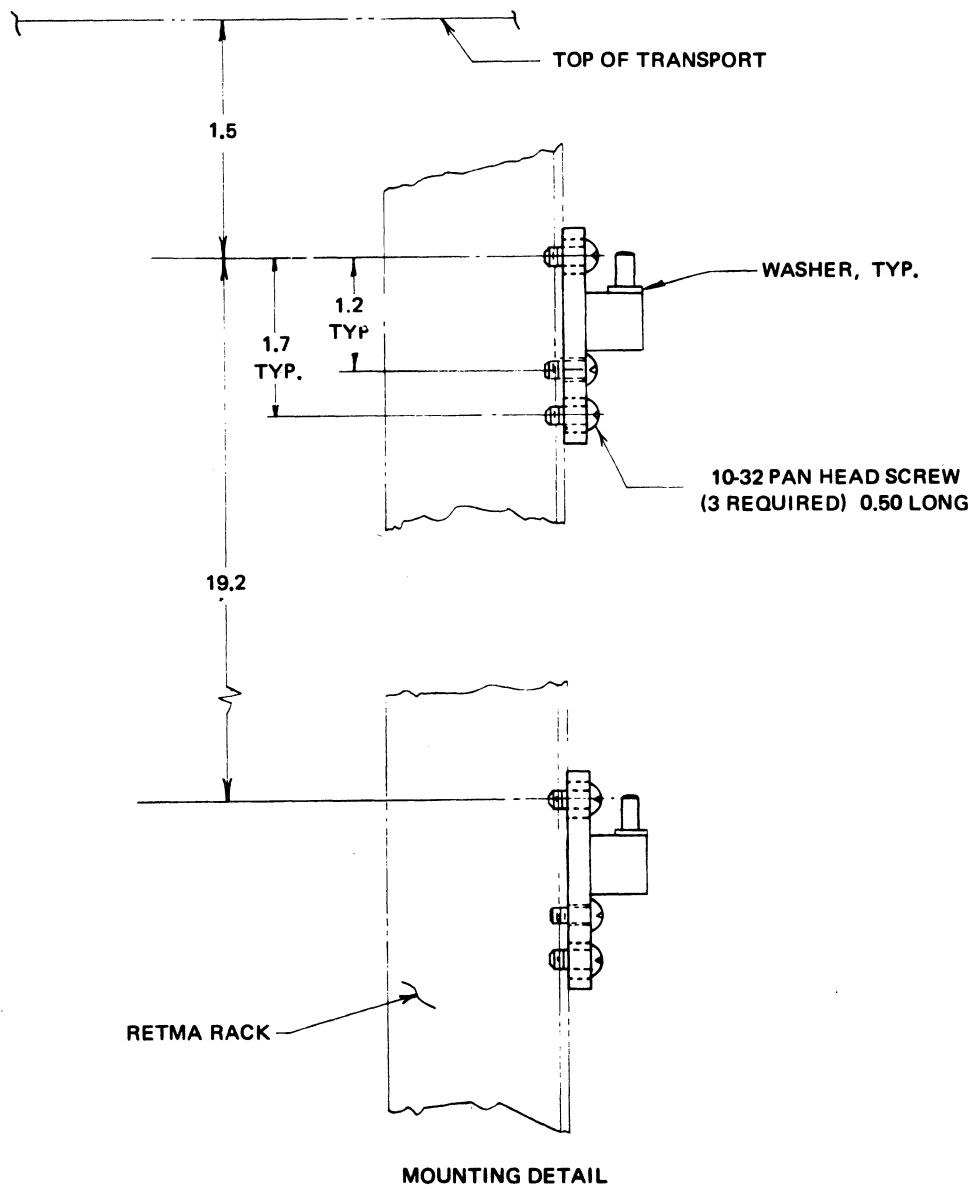
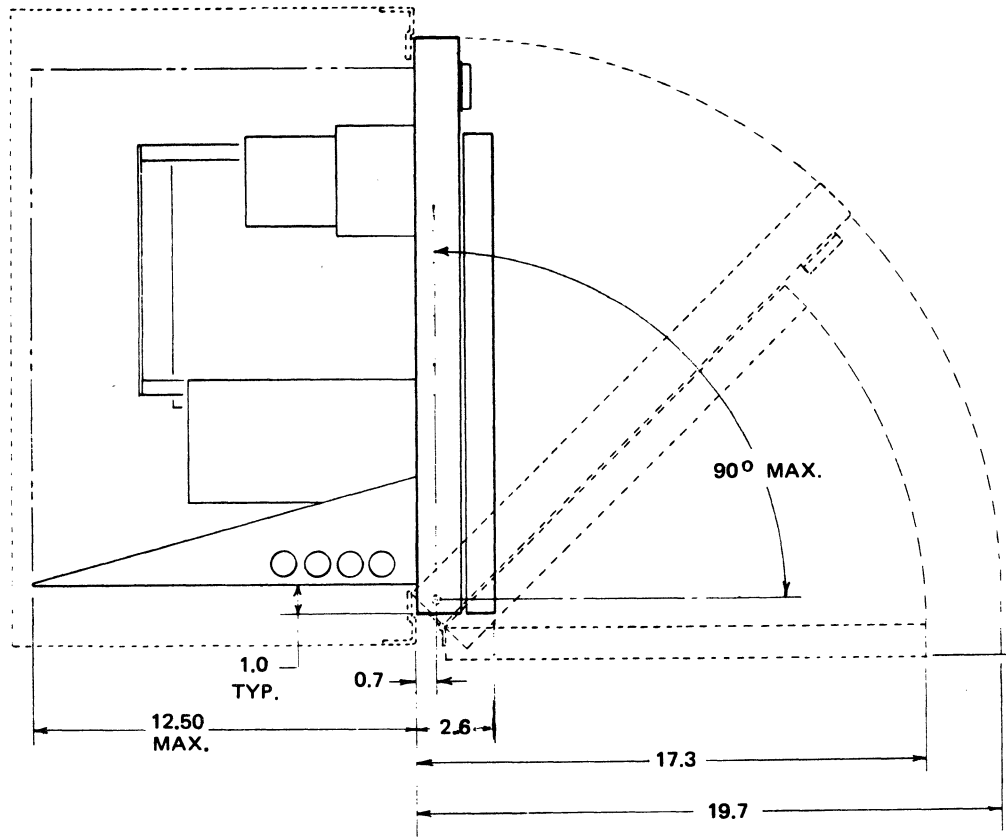

DIMENSIONS IN INCHES UNLESS OTHERWISE NOTED

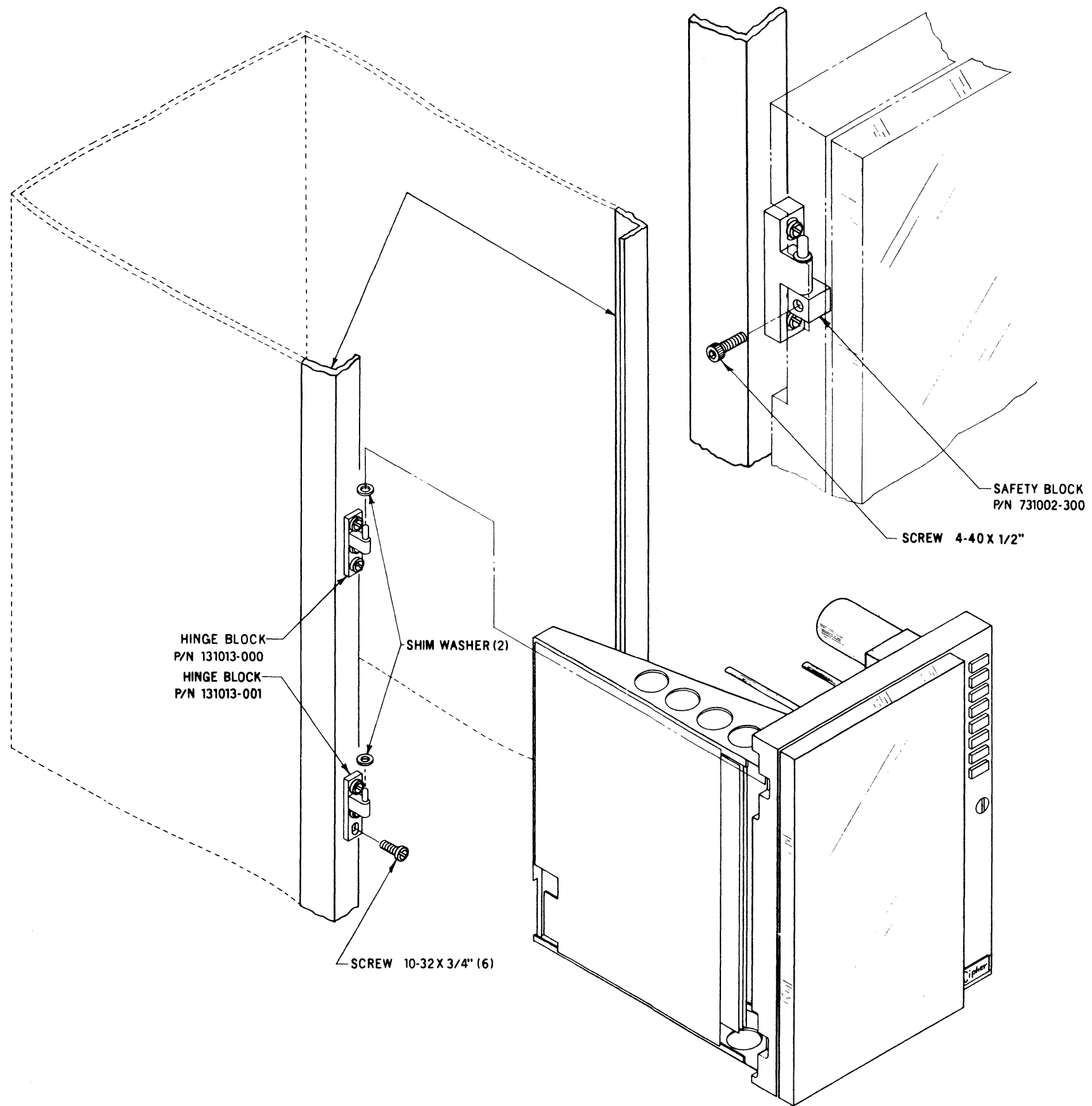

Figure 2-3. Installation Diagram

DESCRIPTION	LIVE PIN	GROUND PIN	SIGNAL
Input Commands J101	J	8	Select (SLT0)
	C	3	Forward (SFC)
	E	5	Reverse (SRC)
	H	7	Rewind (RWC)
	L	10	Off Line (OFL)
	K	9	Write Enable (SWS)
	B	2	Overwrite (OVW)
	15	—	Write Reset (WARS) (part of overwrite option)
	D	4	Data Density Select (DDS)
Output Indications J101	T	16	Ready (RDY)
	M	11	On Line (ONL)
	N	12	Rewinding (RWD)
	U	17	End of Tape (EOT)
	R	14	Load Point (LDP)
	P	13	File Protect (FPT)
	F	6	Density (DDI)
	S	—	+5V (Optional)
Write Inputs J102	A	1	Write Data Strobe (WDS)
	C	3	Write Reset (WARS)
	F	6	Threshold 2 (RTH2)
	L	10	Write Data Parity
	M	11	Write Data 0 (WD0)
	N	12	Write Data 1 (WD1)
	P	13	Write Data 2 (WD2)
	R	14	Write Data 3 (WD3)

Table 2-2. Interface Connections

DESCRIPTION	LIVE PIN	GROUND PIN	SIGNAL
Write Inputs J102 (Continued)	S	15	Write Data 4 (WD4)
	T	16	Write Data 5 (WD5)
	U	17	Write Data 6 (WD6)
	V	18	Write Data 7 (WD7)
Read Outputs J103 (Optional)*	2	B	Read Data Strobe (RDS)
	1	A	Read Data Parity (RDP)
	3	C	Read Data 0 (RD0)
	4	D	Read Data 1 (RD1)
	8	J	Read Data 2 (RD2)
	9	K	Read Data 3 (RD3)
	10	L	Non-Return-to-Zero (NRZ)
	14	R	Read Data 4 (RD4)
	15	S	Read Data 5 (RD5)
	17	U	Read Data 6 (RD6)
18	V	Read Data 7 (RD7)	

*NRZ switches automatically. If HI DEN is true, NRZ is false; if HI DEN is false, NRZ is true.

Table 2-2. Interface Connections (Continued)

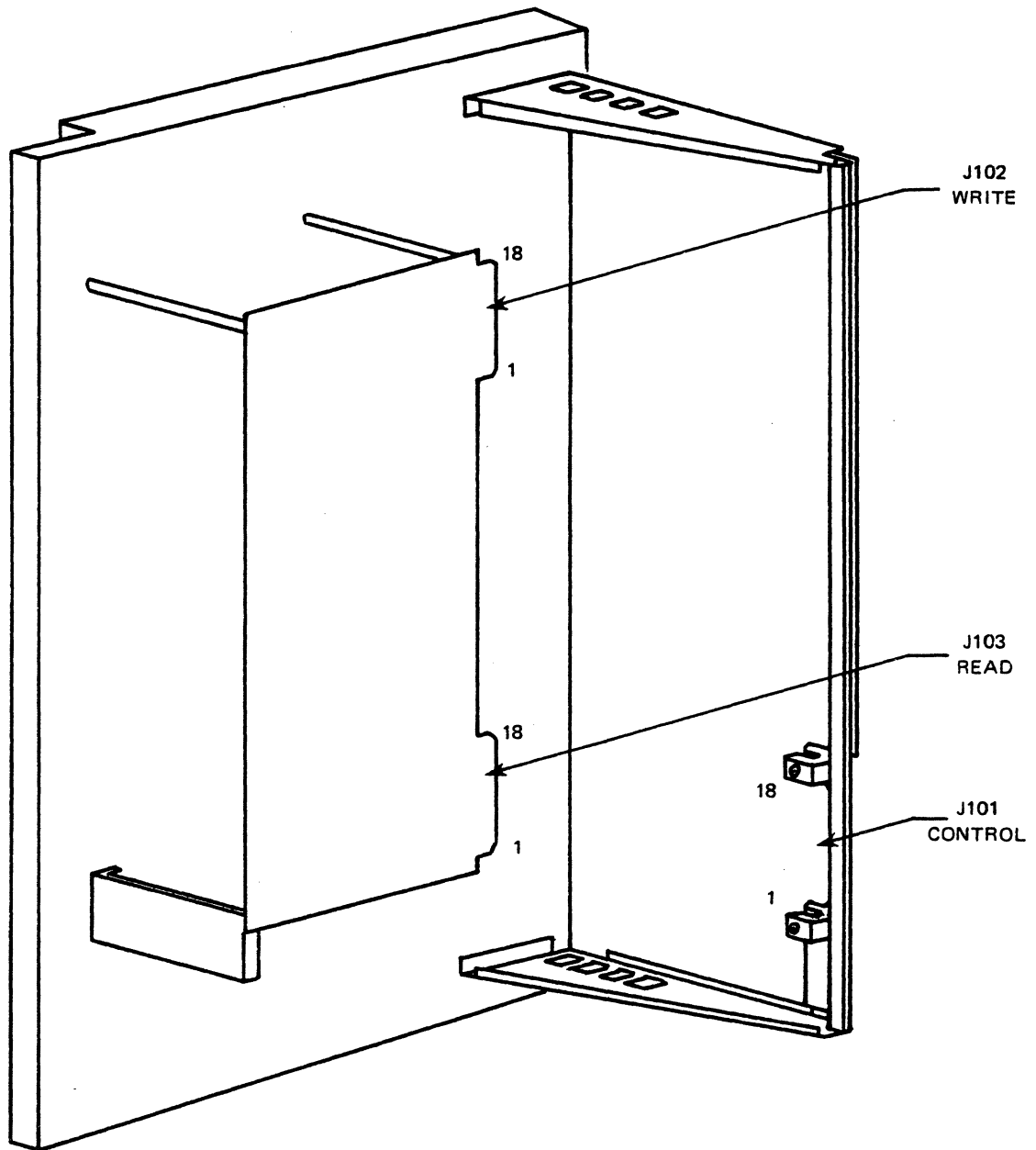

Figure 2-4. Interface Cable Installation

SECTION III

OPERATION

3-1. GENERAL

3-2. This section describes the controls and indicators and provides instructions for operating the Model 100X transport.

3-3. CONTROLS AND INDICATORS

3-4. Figure 3-1 shows the controls and indicators. Control/indicator types, functions, and the conditions required for enabling the corresponding functions are given in Table 3-1.

NOTE

The head and guide-cleaning procedures described in paragraph 5-5 must be performed daily to maintain transport reliability.

3-5. LOADING TAPE

3-6. To load tape, see Figure 3-2 and proceed as follows:

- a. Pull out reel-locking lever on supply hub. Ensure that tape reel has write enable ring installed if write mode is to be utilized. Place reel of tape on hub so that tape will unwind when reel is rotated in clockwise direction. Press reel evenly and firmly against hub's back flange and push in locking lever. Spin reel counter-clockwise while looking along its rim to ensure even mounting.
- b. Install empty reel on takeup hub in same manner as loaded reel was mounted in step a.
- c. Actuate POWER pushbutton. POWER indicator will illuminate, and compliance arms will be driven to full-up positions.
- d. Thread tape along path shown in Figure 3-2. Wrap several turns clockwise

around takeup reel. Check that tape is correctly seated on guides and properly threaded through photosensor and head assembly.



Ensure that tape is positioned correctly on all guides, or tape damage may result.

- e. Close front cover to protect tape and transport from dust.



Dust cover must remain closed at all times when tape is on takeup reel. Data reliability may be impaired by contaminants if cover is left open.

- f. Actuate LOAD pushbutton and observe that tape is tensioned. (See Figure 3-3.) Delay at this point is required to allow arm retractor mechanism to clear compliance arms. Actuate LOAD pushbutton again. Tape will advance until BOT tab is positioned at photosensor. LOAD indicator will illuminate, indicating transport is ready for use.

3-7. UNLOADING TAPE

3-8. To unload the tape, proceed as follows:

NOTE

Transport must be in off-line mode (ON LINE indicator extinguished).

- a. If power is off, actuate POWER pushbutton and proceed to step b. If power is on, start with step c.

- b. Actuate LOAD pushbutton to tension tape.
- c. Actuate REWIND pushbutton. REWIND indicator will illuminate. If tape is at load point tape will rewind until tension is lost. If tape is not at load point, rewind ceases when BOT tab is reached. BOT tab is then positioned automatically at photosensor, and LOAD indicator illuminates. Actuate REWIND pushbutton second time to complete unload sequence.

NOTE

Manual REWIND command will override load sequence. This can be used to return tape to load point in event load sequence is inadvertently initiated after BOT tab has passed photosensor.

3-9. INTERFACE DATA

3-10. Interface specifications are presented in paragraph 1-24. Interface inputs and outputs are listed in Tables 3-2 and 3-3, respectively.

3-11. MULTIPLE-TRANSPORT (DAISY-CHAIN) SYSTEM MODIFICATION

3-12. When two or more transports are used in a "daisy-chain" system, the transmission line (cable) terminators in all transports except the last in the system must be removed, or the resulting impedance mismatch will cause undesirable signal reflections in the cable. The termination impedance networks in the Model 100X transport are all incorporated in two 330-ohm and two 220-ohm resistor packs which plug into integrated circuit sockets. For multiple-transport operation it is necessary simply to remove the four resistor packs from their sockets on all but the last transport. One 330-ohm pack and one 220-ohm pack are located in the bottom, right-hand corner of the control/servo board (component side) near connector J-101, and the other two are located in the upper, center area of the read/write board.

Refer also to Technical Manual No. 799800-200, on the multiple-transport cable assembly, Part No. 138631-000.

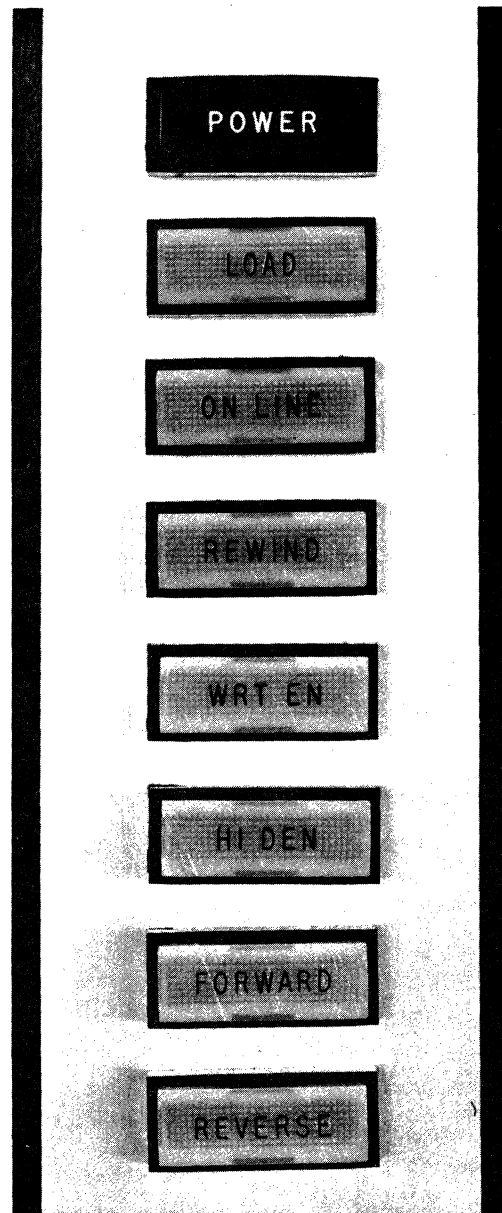

Figure 3-1. Control Panel

CONTROL OR INDICATOR	TYPE	FUNCTION	CONDITIONS
POWER	Alternate-Action Pushbutton/Indicator	Switches line power on and off. Illuminates red to indicate power is on.	Fuse installed. Line cord connected.
LOAD	Momentary-Action Pushbutton/Indicator	Initial actuation energizes motors and servo system and tensions tape.	Power restored after being off. Loss of tape tension.
		Second actuation advances tape to load point.	
		Illuminates to indicate BOT tab is positioned at photosensor.	
ON LINE	Momentary-Action Pushbutton/Indicator	Switches transport to on-line mode. Illuminates to indicate transport is on line.	Initial load or rewind actuation. Transport in off-line mode. (ON LINE indicator extinguished.)
		Second actuation switches transport off line. Indicator extinguished to indicate transport is off line.	Transport in on-line mode. (ON LINE indicator illuminated.)
REWIND	Momentary-Action Pushbutton/Indicator	Rewinds tape to load point. REWIND indicator illuminates during rewinding, then goes out.	Transport in off-line mode. (ON LINE indicator not illuminated.)
		LOAD indicator illuminates to indicate BOT tab is positioned at photosensor.	
		Second actuation of REWIND pushbutton unloads tape.	

Table 3-1. Controls and Indicators

CONTROL OR INDICATOR	TYPE	FUNCTION	CONDITIONS
WRT EN (Write Enable)	Indicator	Illuminates to indicate write function may be performed.	Tape reel with write enable ring installed mounted on supply hub.
HI DEN (High Density)	Alternate-Action Pushbutton/Indicator	First actuation (illuminated), followed by FORWARD or REVERSE command, selects PE mode. Second actuation (extinguished), followed by FORWARD or REVERSE, selects NRZI.	C-F jumper installed on control/servo board.
FORWARD	Alternate-Action Pushbutton/Indicator	Starts/stops tape forward motion. Illuminates to indicate transport in forward mode.	Transport in off-line mode (ON LINE indicator extinguished).
REVERSE	Alternate-Action Pushbutton/Indicator	Starts/stops tape reverse motion. Illuminates to indicate transport in reverse mode.	Transport in off-line mode (ON LINE indicator extinguished).

Table 3-1. Controls and Indicators (Continued)

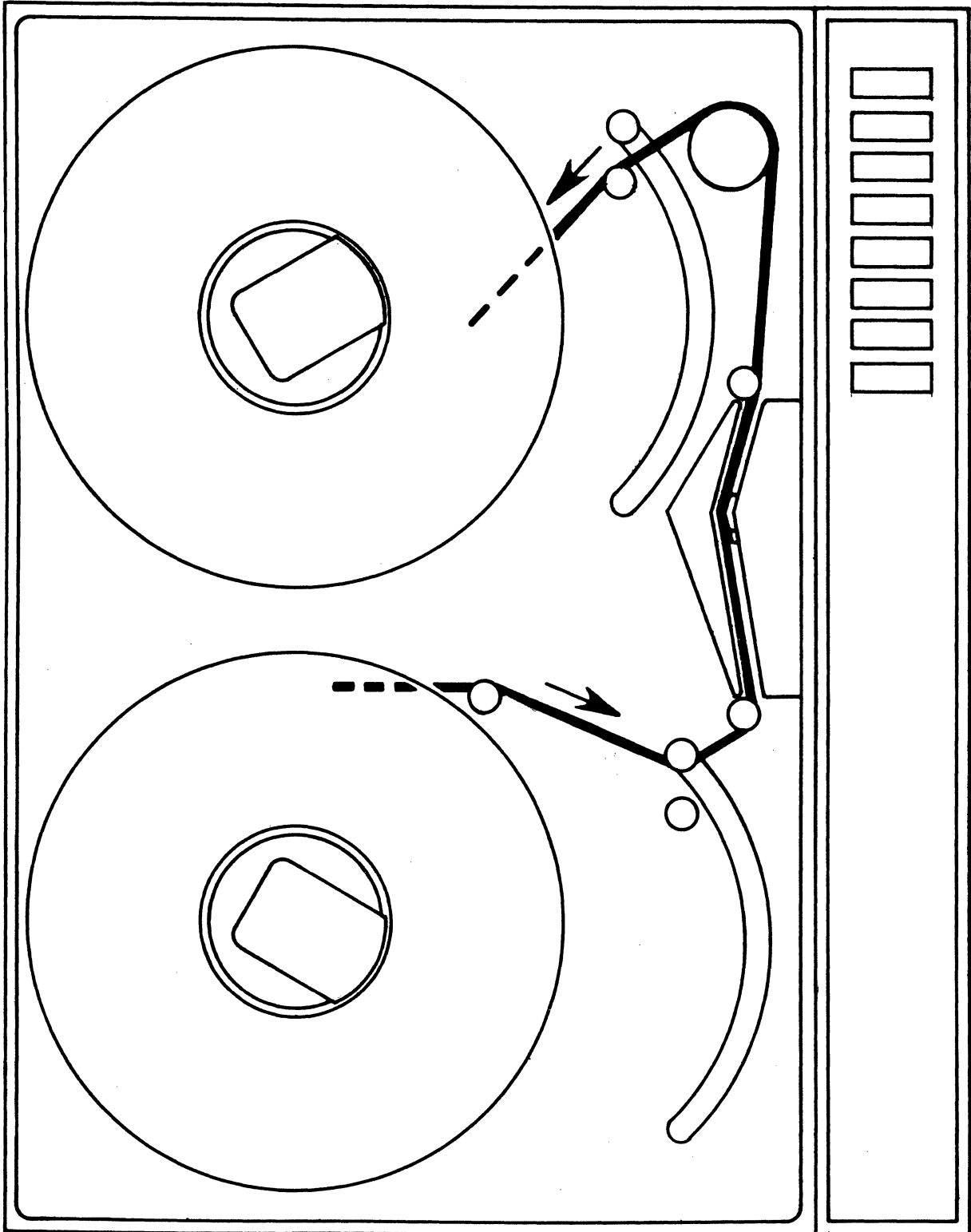

Figure 3-2. Tape-Threading Path

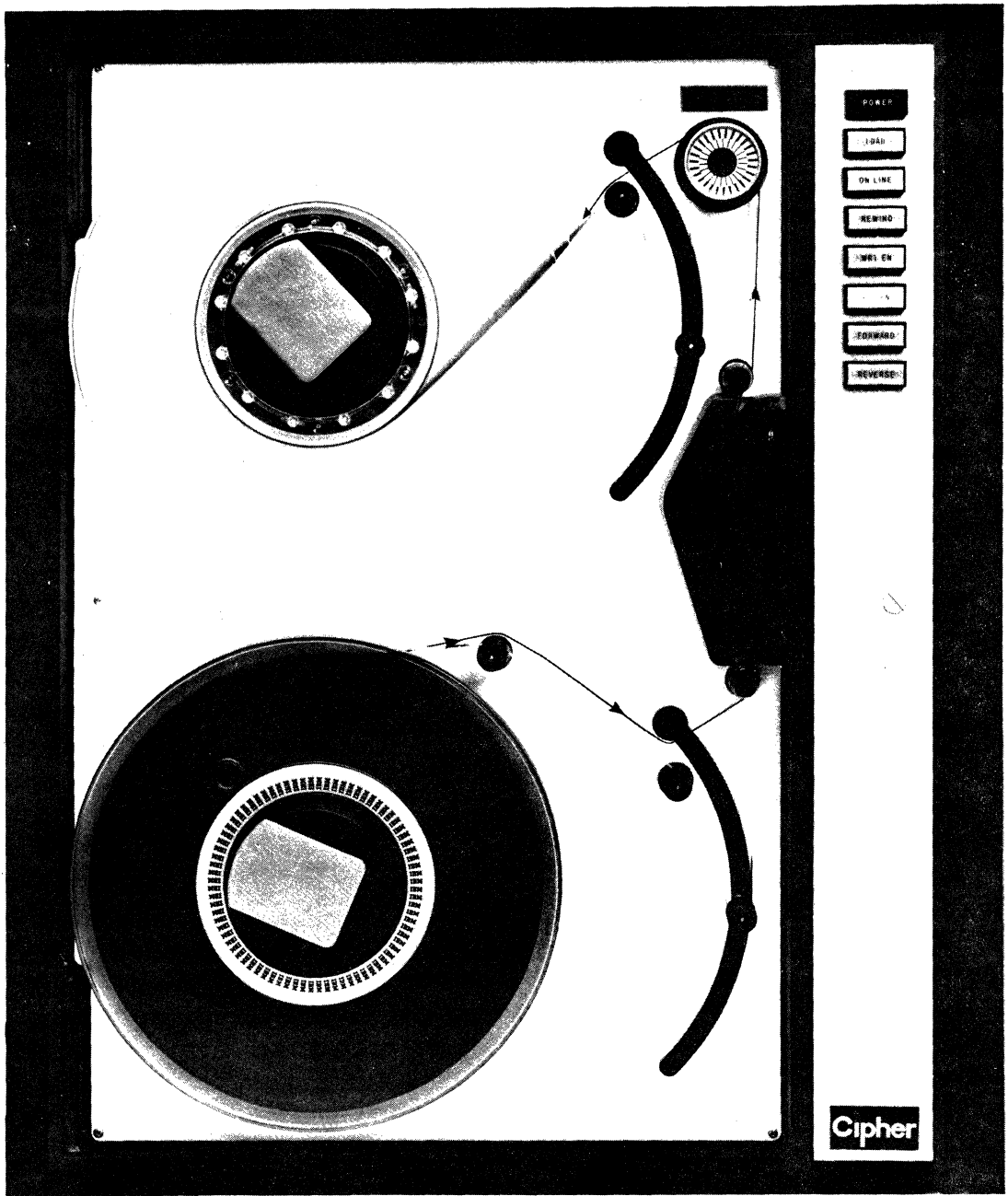

Figure 3-3. Operating Configuration (Tape Tensioned)

INPUT	TYPE	FUNCTION
Select (SLT0)	Level	When true, enables all interface drivers and receivers in transport, thus connecting transport to controller.
Forward (SFC)	Level	When true, with transport ready and on line, causes tape to move forward at specified speed.
Reverse (SRC)	Level	When true, with transport ready and on line, causes tape to move in reverse at specified speed.
Rewind (RWC)	Pulse	With transport ready and on line, this pulse causes tape to move in reverse at 150 ips to BOT.
Off-Line (OFL)	Level or pulse (min. width, 1 microsecond)	Resets on-line flip-flop to 0 state, placing transport under manual control.
Write Data Strobe (WDS)	Pulse (min., 1 microsecond)	Leading edge triggers code generator in transport.
Write Data (WD)	9 lines for 9-track	When true from 0.5 microsecond before leading edge to 0.5 microsecond after leading edge of write strobe, results in recording of flux transition when in NRZI write mode; in PE, selects flux direction.
Write Enable (SWS)	Level	When true for 20 microseconds, minimum, after leading edge of FORWARD or REVERSE command, initiates write mode of operation.
Reset (WARS)	Pulse (min., 1 microsecond)	When true, resets write amplifier circuits on leading edge. In NRZI mode, purpose is to write LRCC at end of record, causing all channels to be erased in IRG; in PE, resets write amplifier.
Data Density Select (DDS)	Level	When true for 20 μ s, minimum, after leading edge of SFC or SRC command, conditions read electronics to operate in PE mode. When false for same period, operation is in NRZI mode.
Overwrite (OVW)	Level	When true, conditions appropriate circuitry, in conjunction with Write Reset (WRS) pulse, for updating (rewriting) of select record. Transport must be in write mode.

Table 3-2. Interface Inputs

OUTPUT	TYPE	FUNCTION
On-Line (ONL)	Level	When true (on-line flip-flop set), transport is under remote control. When false, transport is under local control.
Read Data (RDP, RD0-7)	Bits	Sampling of RDP, RD0-7 simultaneously (on leading edge of read data strobe (RDS) in NRZI only) provides complete data character.
Read Data Strobe (RDS)	Pulse (3/64 of data cell, NRZI, 800bpi)	Provides complete data character when RDP, RD0-7 sampled on trailing edge. (NRZI mode only.)
End of Tape (EOT)	Level	True for duration of EOT tab. Transitions to and from true state not to be assumed clean.
Density (DDI)	Level	True when transport is set for PE mode.
Ready (RDY)	Level	True when load sequence is complete and transport is on line and not rewinding. (Transport ready to receive remote command.)
Load Point (LDP)	Level	True when BOT tab is under photosensor, initial load sequence is complete, and transport is not rewinding.
Rewinding (RWD)	Level	True only when transport is engaged in rewind operation or load sequence following rewind.
File Protect (FPT)	Level	True when power is on and reel of tape without write ring is mounted on transport.
NRZI Transport Identification (NRZ)	Level (Optional)	True when transport is conditioned for NRZI data. False for phase-encode mode.
7-Track Head Identification (7TK)	Level (Optional)	True for 7-track transport; false for 9-track configuration. (Not used.)
Single-Gap Head Identification (SGL)	Level (Optional)	True when transport has single-gap head; false level indicates dual-gap head. (Not used.)
Transport Speed Identification (SPEED)	Level (Optional)	True when transport has lower of two speeds available in multiple-transport system.

Table 3-3. Interface Outputs

SECTION IV

THEORY OF OPERATION

4-1. GENERAL

4-2. The basic concepts of digital recording, magnetic tape transport applications, and principles of operation of the Model 100X dual-mode transport are presented in this section. A thorough knowledge of this section will be of considerable value to the user in operating and, if necessary, in troubleshooting this equipment.

4-3. BASIC CONCEPTS OF DIGITAL RECORDING

4-4. The use of magnetic tape as a digital recording medium has increased steadily as a result of the increased use of digital techniques and the increasing versatility and decreasing cost of tape transports. The digital recording process involves methods and equipment capable of recording and reading information expressed in a digital (binary) code (various combinations of 1's and 0's).

4-5. DATA RECORDING/READING WITH MAGNETIC TAPE

4-6. The recording of data on magnetic tape originates with the input device, whose nine channels of digital signals are transmitted to the corresponding data channels of the transport. (One of these channels is the parity channel, which is used to detect and correct errors. The remaining channels correspond to actual encoded data to be recorded.) These signals produce corresponding electrical currents in the write head of the transport, which, in turn, produces positive and negative magnetic polarities corresponding to the original data and parity signals in the tracks of the tape passing over it. In NRZI systems, a binary 1 signal in a given channel produces a transition from plus to minus (or vice versa) saturation magnetism (+SAT and -SAT, Figure 4-1) in its track on the tape, whereas a binary 0 signal produces no change in magnetism in its track. In phase-encode writing, a binary 1 signal produces a transition to the IBC polarity on the tape when running forward (Figure 4-2); a binary 0 produces a transition away from IBC.

4-7. As a written tape passes across the magnetic read head of a transport, the head responds to each change of flux arriving at its gap and produces a read voltage waveform for each track such as illustrated in Figure 4-1 (NRZI) or Figure 4-2 (PE). (See paragraph 4-12 for a detailed description of magnetic tape recording/reading in the NRZI mode, paragraph 4-20 for phase-encode.)

4-8. MAJOR TRANSPORT COMPONENTS

4-9. The Cipher Model 100X transport is composed of four main assemblies (Figure 4-3): the drive assembly, which includes the tape drive components and the compliance arm system; the read/write system, consisting of a head assembly and a dual-mode data board; a control/servo board containing the transport control circuitry, the reel and capstan motor servos, and the power supply regulator circuits; and a power supply, consisting of the power transformer mounted on the rear of the mounting plate, the power supply circuit board, and the front-panel-mounted power switch and indicator. The schematic diagrams in Section VII should be referred to in studying circuit descriptions presented in this section.

4-10. HEAD ASSEMBLY. The Model 100X dual-mode transport has a dual-gap head for read-after-write operation. Track locations, track width, and gap separation are all IBM-compatible (Table 4-1).

4-11. A cross-feed shield is provided to reduce the voltage induced in the read head when writing. The shield is composed of copper and ferrite flux blocks cemented to a hinge plate (Section V, Figure 5-3).

4-12. NRZI CODING SYSTEM

4-13. In the NRZI system, recording is carried out by a saturation current driven through the head in a direction determined by a flip-flop which toggles for each 1 bit recorded. The NRZI system requires the recording of at least one bit for every character. Otherwise, in an all-0 character there would be no indication of the presence of that character.

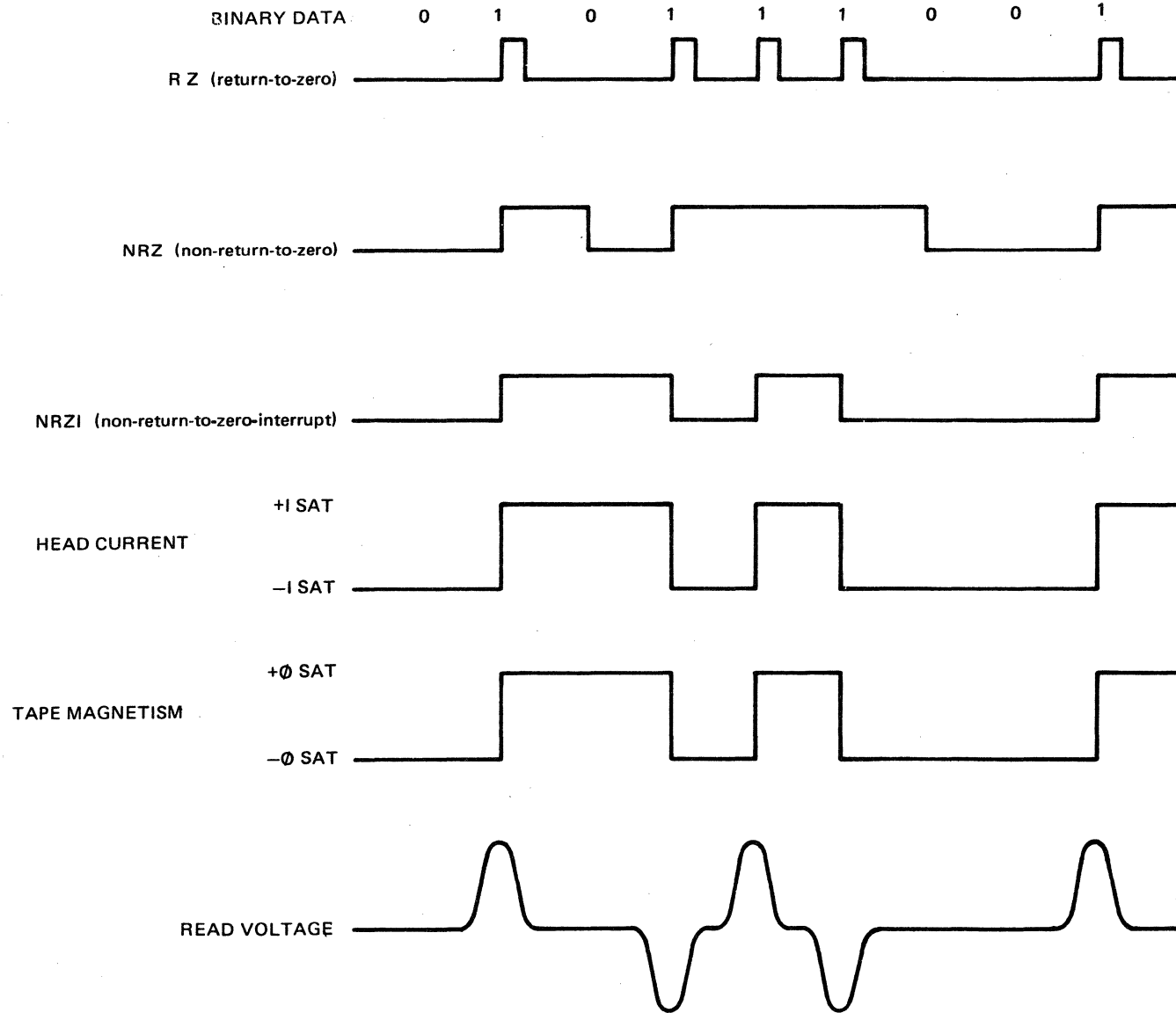

Figure 4-1. Magnetic Recording Waveforms

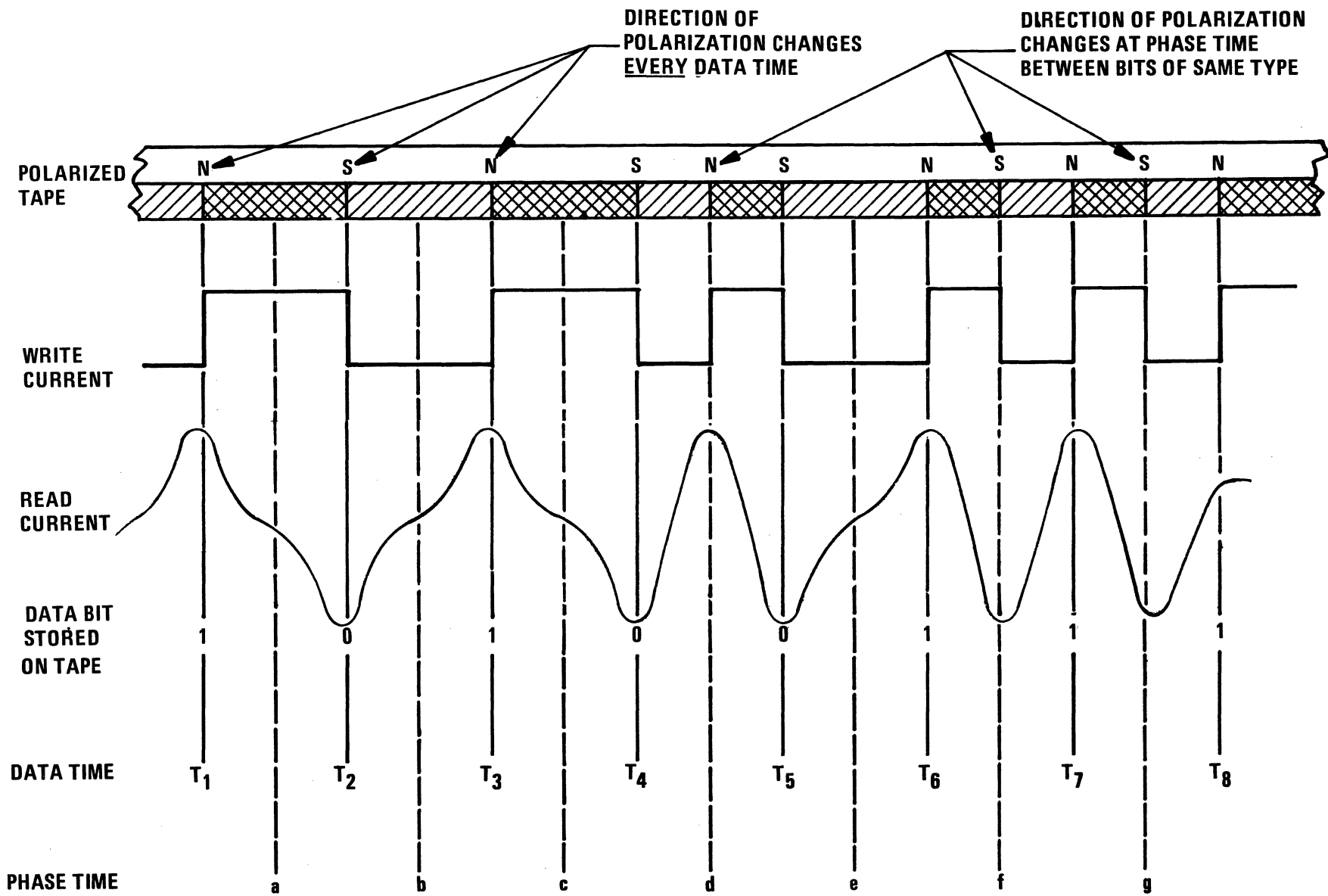

Figure 4-2. Phase-Encoded Tape Magnetization

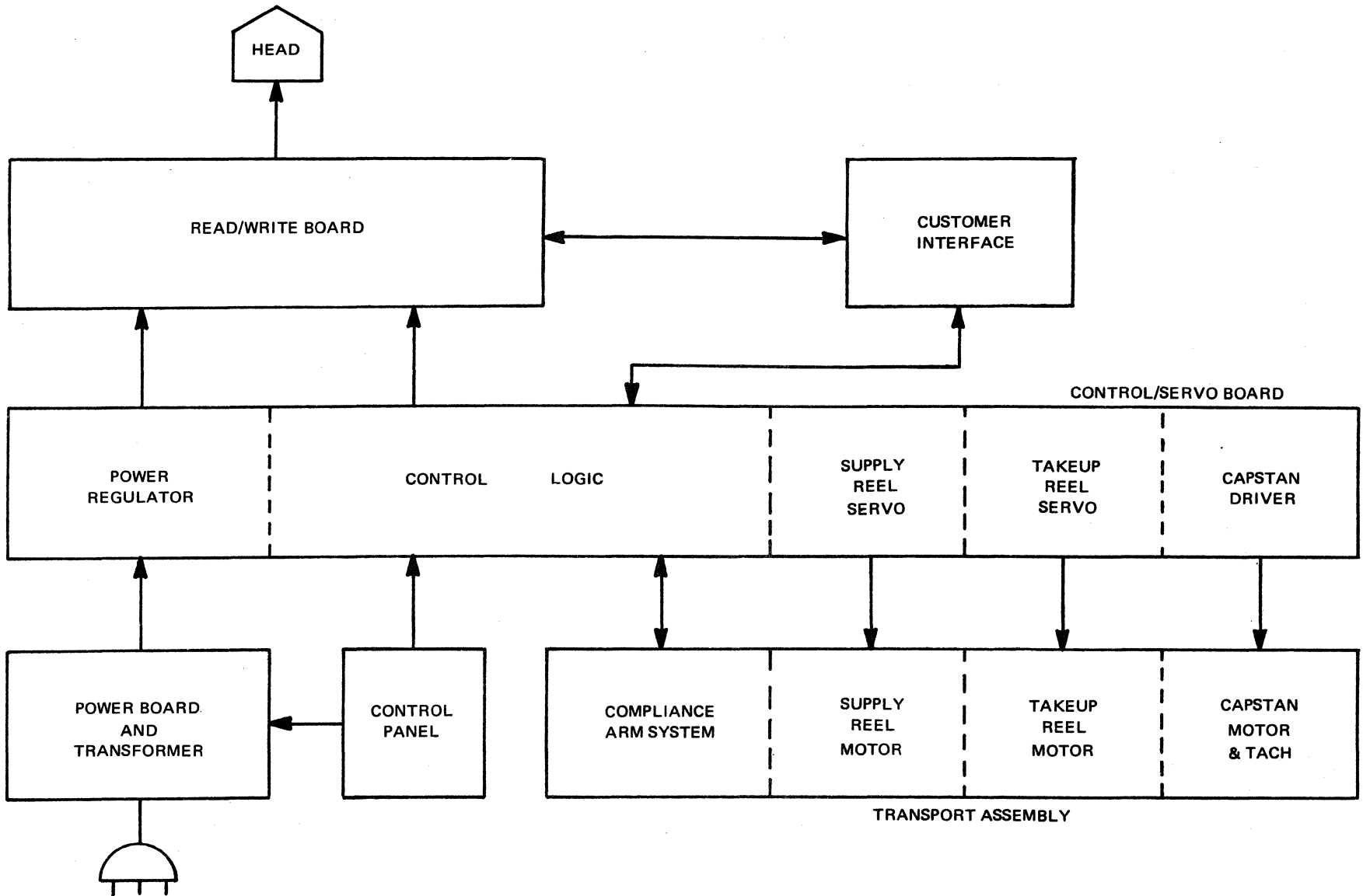

Figure 4-3. Transport Organization

FUNCTION	SPECIFICATION
Track Locations	0.055 (± 0.001) inch, center to center
Effective Track Width	Write: 0.044 (± 0.001) inch Read: 0.040 (± 0.001) inch
Parallelism	± 200 microinches (write to read)
Gap Separation (Write-Read)	0.150 (± 0.005) inch
Gap Line Azimuth Per Section	± 150 microinches maximum from reference perpendicular to mounting surface
Gap Scatter Per Section	100 microinches, maximum
Crosstalk	
Read	2%, maximum, of nominal read voltage
Voltage Induced in Read Winding While Writing at 800 bpi, 12.5 ips, and up	5%, maximum, of read voltage
Write Current (100% saturation)	40 mA, NRZI 20 ma, PE
Read Voltage	30 mV (typical) at 45 ips
Self Erasure (Read Signal Reduction After 10 Passes)	10% maximum
Erase Current	50 mA

Table 4-1. Head Specifications

4-14. In the IBM system nine-track tape, a modified ASCII code is used. (See Figure 4-4.) Parity in the nine-track, 800-bpi system is always odd. With this system, when programmed properly, it is possible to write data in the binary mode. Two four-bit numerics per byte may be written, with a consequent doubling of effective data rate.

4-15. LONGITUDINAL REDUNDANCY CHECK CHARACTER (LRCC). A longitudinal parity bit is written at the end of each record. This character is written by the return of the write head current to the reference condition. Since the reference condition is established before the first character of the record and reestablished by writing of the LRCC, an even number of 1 bits is written in each track for each record. As the tape is read, the number of 1's read in each track is counted. If the sum is odd, an error is indicated. The LRCC is spaced four character spaces from the end of the block.

4-16. CYCLIC REDUNDANCY CHECK CHARACTER (CRCC). Nine-track, 800-bpi tapes include a CRCC located at the end of each record before the LRCC. The CRCC is generated by application of a complex equation of the data within the block. This character makes the probability of an undetected error almost zero. The CRCC may be used with the computer read function to determine which track contains the error.

4-17. The information supplied by the CRCC, combined with that of the LRCC and vertical parity, may be used to correct detected errors. Errors involving more than one track within the same record are detected but not correctable.

4-18. LOST-CHARACTER CHECK. The system incorporates a lost-character check which detects, during reading, the loss of a complete byte. A byte is assumed lost if the time between bytes is longer

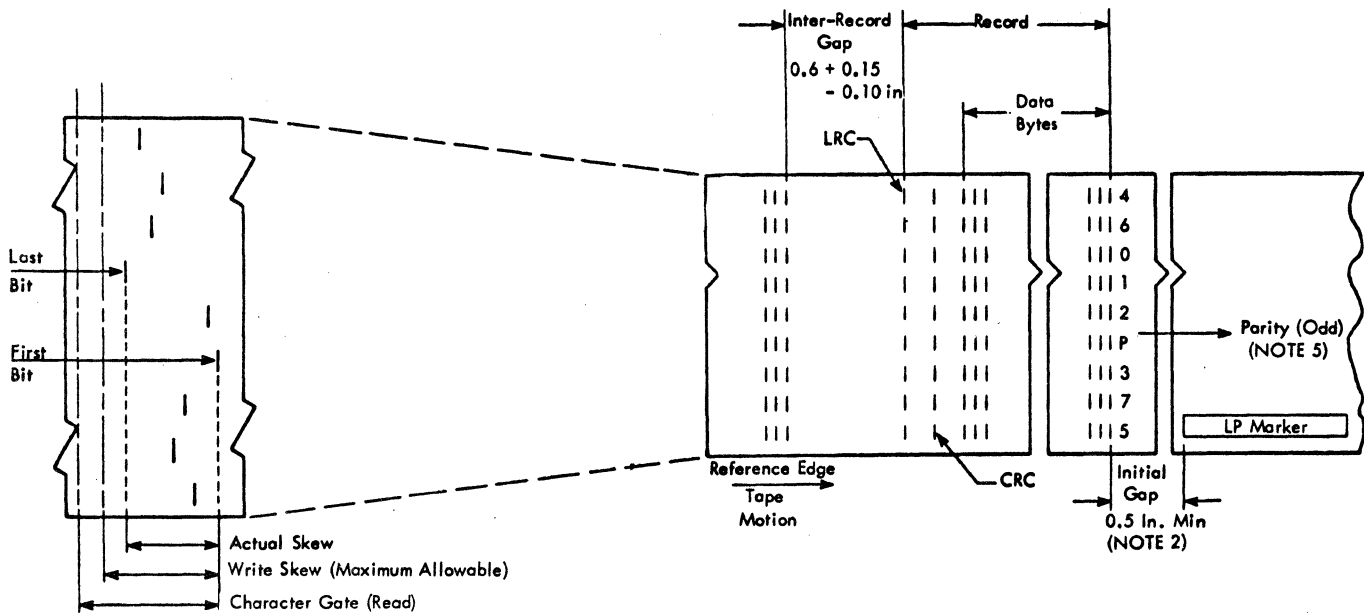

- NOTES:
1. Tape shown with oxide side down; NRZI recording. Bit produced by reversal of flux polarity. Tape fully saturated with each direction.
 2. Tape to be fully saturated in erased direction in initial gap and inter-record gap; tape to be magnetized so that rim end of tape is north-seeking pole.
 3. CRCC: cyclic redundancy check character. Parity of CRCC determined by number of data characters in record. Odd number of data character, even CRCC, etc. CRCC used only in System 360, 800 bpi. CRCC spaced four bits from data characters.
 4. LRCC: longitudinal redundancy check character, always odd parity. Spaced four bits from CRCC.
 5. Parity bit: vertical parity bit written for each character containing even number of bits.

Figure 4-4. Nine-Track Data Format

than normal but not long enough for check character spacing.

4-19. The lost-character requirement limits the instantaneous variation of byte spacing on the tape being read. With the Cipher Model 100X transport, a byte spacing tolerance well within the limits set by the lost-character check is assured.

4-20. PHASE-ENCODE SYSTEM

4-21. Phase-encoded (PE) recording offers several advantages over other types, most important of which are the reduced possibility of losing data because of inadequate signal strength (making practical low read thresholds) and the fact that each track is self clocking, reducing skew problems. Operation is in a nine-track mode only. Basic features of the PE system (in forward direction) are as follows (Figure 4-2):

- a. There must be a change of tape polarity between data bits of the same polarity (consecutive 1 or 0 bits) at phase time.

- b. There must be a change of tape polarity at each data bit time.
- c. There must not be a change of tape polarity at phase time between 1 and 0 bits.
- d. A change of tape polarity at bit time, when reading forward, to IBC level is a 1; away from IBC, a 0.
- e. The PE transport records and reads data at a density of 1600 bits per inch (bpi).

4-22. For clarification, the term "change of polarity" is also referred to as a flux change or flux reversal. As noted above, there must be a flux reversal with each data bit, whether it be a 0 or 1. Therefore, 1600 bpi equates to a minimum of 1600 frpi in any given channel. (This would occur in the case of alternate 0 and 1 bits.) The maximum case would occur with consecutive 0 or 1 bits, resulting in 3200 frpi. The flux reversal at each bit time accounts for the self-clocking feature of PE writing.

4-23. **FORMATTING.** Phase-encode formatting is illustrated in Figure 4-5. The format includes an inter-record gap (IRG) and file gap (FG), a data generation and file mark, and an identification burst. A block of PE data is preceded and immediately followed by a burst of bytes designated preamble and postamble, respectively. The sequence for a block of PE data is as follows:

- a. Forty bytes of all 0's (including the parity bit).
- b. One byte of all 1's (including the parity bit).
- c. Data bytes.
- d. One byte of all 1's.
- e. Forty bytes of all 0's.

4-24. A phase-encoded tape requires an identification burst of 1600 frpi in the P channel and erasure in all other channels at the beginning of the tape. The burst must begin at least 1.7 inches ahead of the leading edge of the beginning of tape (BOT) marker and extend beyond the trailing edge of the marker. The load gap requirements are the same as those for NRZI, except that the 0.5-inch minimum gap is referenced from the identification burst. The typical distance for a load gap is 3.75 inches.

4-25. The PE file mark or tape mark consists of a minimum of 64, maximum of 256, flux reversals at 3200 frpi, written in channels 2, 6, and 7, with channels 1, 3, and 4 dc erased. Channels 0, 5, and P, in any combination, may be dc erased or recorded the same as channels 2, 6, and 7.

4-26. DUAL-MODE DATA PWB THEORY (Drawing No. 354040-300)

4-27. **CONTROL SECTION** (Sheet 5). The data board control section consists of the following circuits:

- a. Read threshold offset voltage.
- b. PE or NRZI selection.
- c. Transport select.
- d. Voltage regulators.
- e. Write voltage control.

4-28. The threshold circuitry selects a high read threshold when writing. RTH2 selects an extra low read threshold, which is helpful for reading old tapes. The threshold voltages are determined by

resistors R14, R15, R25, and R20. The voltage varies in relation to S2 (4-11), S2 (5-10), RTH2, and READ.

4-29. The transistor driven by U17-12 allows some current to be shunted to ground through R16. This transistor is on for PE operation, and current being shunted in this manner will reduce the gain of U16-1 by a factor of two-thirds. The outputs of U16 cause the threshold detector of each channel to have a negative or positive offset, depending on whether TH- or TH+ is the input. The highest threshold can be obtained by closing both S2 (4-11) and S2 (5-10). When both switches are open, the lower threshold will be selected. With S2 (4-11) closed and S2 (5-10) open, normal threshold detection is used.

4-30. **WRITE VOLTAGE CONTROL** (Sheet 5). Control for the write voltage circuit is provided by the low-true NOR gate U114-8. When WTEST or the output of exclusive OR-gate U108-8 goes low, U92-4 goes low. This low causes Q5 to start conducting. The large capacitor, C103, gives the circuit a Miller integrator configuration. C103 charges to +12V through Q5. L4, which consists of ferrite beads, filters the switching noise to prevent it from being applied to the write circuitry. Zener diode CR4 allows the write circuitry to be used with both high- and low-speed tape heads without changing resistor values in the write-head drivers. The high-speed head requires more current, which is provided by closing of SW3 (2-7); this increases the current by about 50%. The write voltage is supplied to the center tap of the write head.

4-31. Q2 senses the voltage from the center taps of the write head, starts conducting, and supplies current for the erase bar, P21-H. Q6 and Q4 form a protection circuit to eliminate glitches from the write head when the transport is being powered up initially. This could cause data to be erased during the power-on sequence, as in the case of a file-protected tape. Initially, Q4 is on. As the +12 volts increases, the voltage divider action of R284 and R283 will cause the base emitter junction of Q6 to become back-biased, and Q6 will turn off. With Q4 on, the base of Q5 will not become negative enough to turn on Q5.

4-32. **VOLTAGE REGULATORS.** There are two voltage regulators supplied on the board. Model 70X, 80X, and 100X tape transports supply +15 volts to the data board. The regulators are used to reduce the ± 15 volts to a regulated ± 12 volts.

4-33. **CONTROL SIGNALS.** RUN comes from the control/power board as a low true signal. It passes through inverter U21-4 and triggers a one-shot

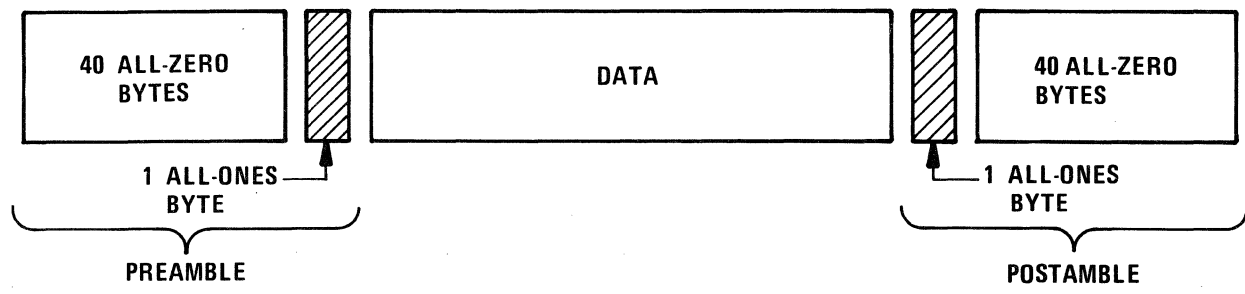
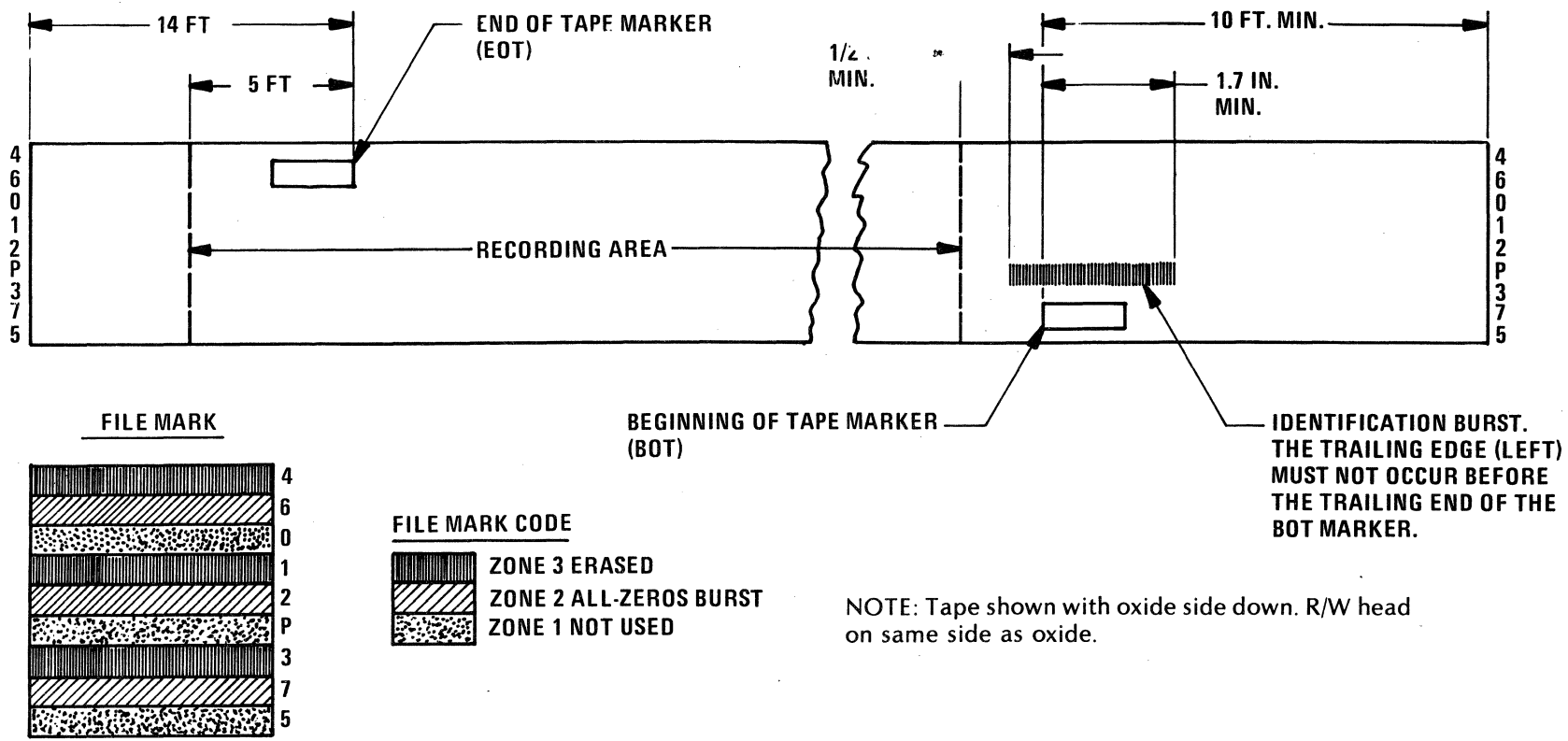

Figure 4-5. Phase-Encoded Tape Block Format

multivibrator, U2. U2-4 provides a positive, 5- μ s pulse.

4-34. This pulse will clock D-type flip-flop U18. The D input is dependent upon the control signal, $\overline{\text{HIDEN}}$, which comes from the control/power PWB also. Since $\overline{\text{HIDEN}}$ is low true, it causes the data PWB to be PE selected. When $\overline{\text{HIDEN}}$ is high false, it initiates the NRZ mode of operation.

4-35. PE OR NRZI SELECTION. Switches S2 (8-7) and S2 (9-6) force density selection for test purposes. When both sections of S2 are open, $\overline{\text{NRZ}}$ is low true. If S2 (9-6) is closed, $\overline{\text{NRZ}}$ will be high false, which causes the PWB to operate in a PE mode. When S2 (7-8) is closed, the control signal $\overline{\text{HIDEN}}$ will control remotely the operable mode of the data electronics.

4-36. WRITE DATA SECTION. The write data section of the dual-mode PWB consists of the following:

- a. Write input register.
- b. NRZI write deskewing circuitry.
- c. WDS and WARS generation circuitry.
- d. Write output register.
- e. Tape head drivers.

4-37. Referring to Figure 4-6 and sheet 1 of the schematic diagram, Drawing No. 354040-300, the theory presented herein is based on channel P but is applicable also to the eight additional channels. The write data interface lines at connector P102 have 220/330-ohm input terminators that provide impedance matching and serve as pull-up resistors for the transmitters at the other end of the data cable. U112-12, a hysteresis receiver, is used to buffer the data lines. The write input register, U105, is used to store the incoming data from the interface. The data is latched into the write input register when Write Strobe ($\overline{\text{WSTRB}}$) occurs. Referring to sheet 5 of the schematic, the Write Data Strobe (WDS) is brought from the formatter/controller. Its frequency is equal to the data rate in the NRZI mode and twice the data rate in the PE mode.

$$\begin{aligned}\text{NRZI WDS frequency} &= \text{speed} \times 800 \text{ bpi} \\ \text{PE WDS frequency} &= 2 \times \text{speed} \times 1600 \text{ bpi} \\ \text{Data rate} &= \text{speed} \times \text{bit density}\end{aligned}$$

4-38. The WDS enters the data board at P102-A and propagates through U112-6. R259 and C113

provide noise filtering before the WDS fires the one-shot multivibrator, U115-12. The output will be a negative 100-ns pulse, which becomes $\overline{\text{WSTRB}}$ and clocks write input register U112. The exclusive OR gate, U108-3, causes the write input register to operate as a toggling J-K flip-flop in the NRZI mode for each 1 bit or follow the data bits (1's or 0's) in the PE mode, similar in operation to a D-type flip-flop. The control signal, Phase Encode (PE), will direct the exclusive OR gate as to the mode of operation.

4-39. The write output register (U99) will be clocked each transition time and will store the data from the write input register, U105. The clock for U99 is derived basically from the WDS also. The output of U115-12 (sheet 5) also goes to the low true NOR gate, U114-4. The output of U114-6 will be a negative 100-ns pulse designated $\overline{\text{CYCLE P}}$. This signal will initialize the operation of the NRZI write deskewing circuit.

4-40. NRZI Write Deskewing Circuit. This feature of the data PWB eliminates the need for nine adjustable one-shot multivibrators. The NRZI deskewing circuits make allowance for the gap scatter present in the write head. Electronically, the writing of each track is adjusted so that the final result is a precise vertical character written on the tape.

4-41. The circuit consists of a voltage-controlled oscillator, U89; synchronous, four-bit counter, U91; and a 256-bit, bipolar, programmable ROM (32 \times 8 PROM), U90. The output frequency of the oscillator is controlled by the external capacitor, C92, which is chosen to match the tape transport speed; the resistor divider consisting of R213 and R212 restricts the frequency range of operation. U89-6 is the chip Enable input and goes low when the $\overline{\text{CYCLE P}}$ signal asynchronously clears the four-bit counter. The counter controls the address inputs of the PROM. The output of the PROM is all 1's, except for the specific channel that is being written. Channel 2 has a fixed count of eight, provided by exclusive OR gate U109-8. (Channel 2 was picked as the reference channel because it is the center track of the write head.)

4-42. The clock for the counter is supplied by the oscillator. The counter will count from 0 through 15; at this time, the carry output of the counter will disable the oscillator at U89-6. The counter increments on the positive edge of the clock, and the PROM writes on the negative edge. The write skew should hold near 6% of the byte time. (The PROMs

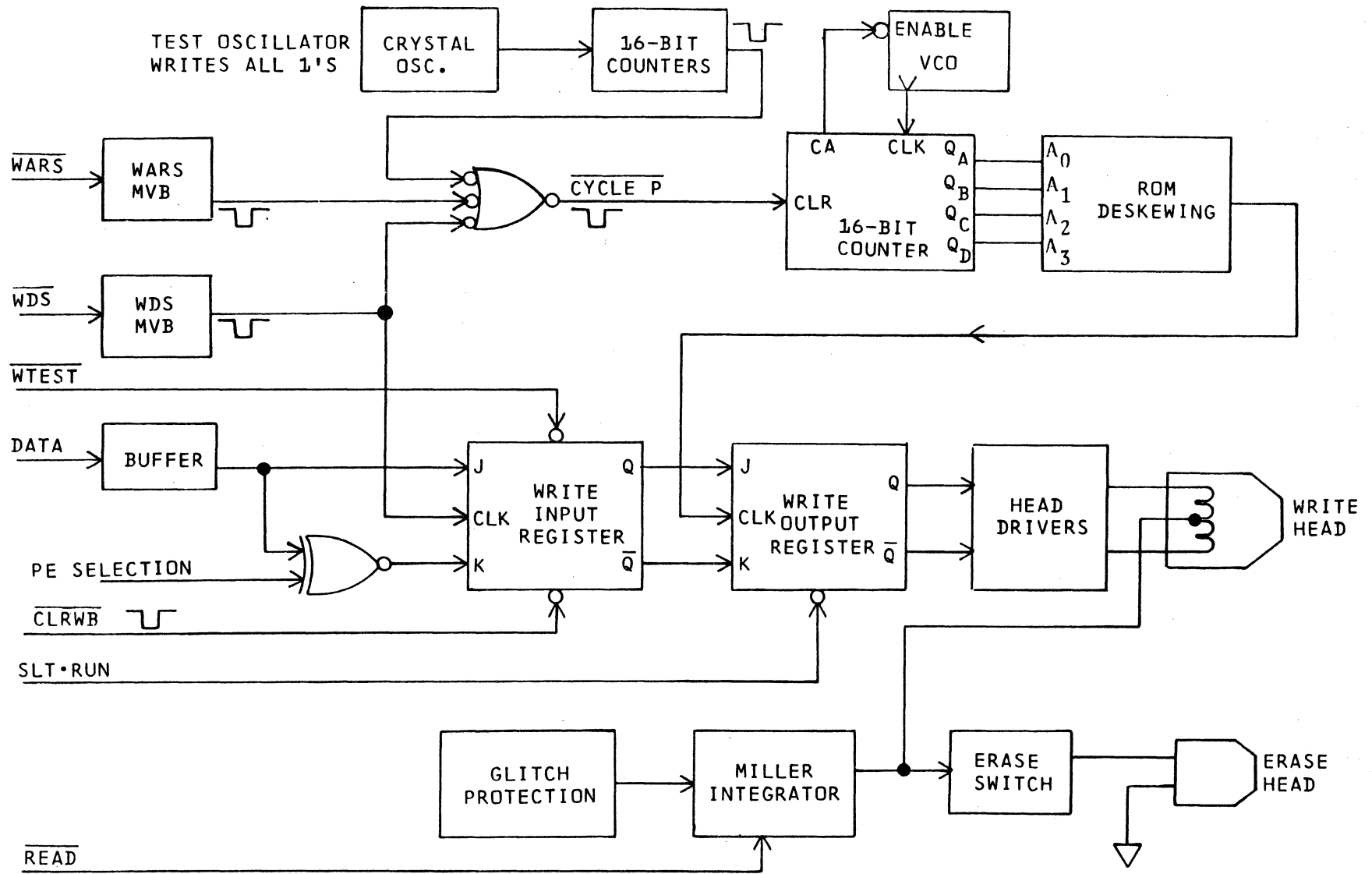

Figure 4-6. Write Data Block Diagram

are serialized with the tape head assembly, and they are replaced as a pair if the need arises.)

4-43. There are four write head drivers following the write output register. The inner two head drivers are used for both PE and NRZI operation, while the outer two head drivers are used only for NRZI operation. P21-N and P21-K are attached to the write head winding with center taps (shown on sheet 5 of the schematic) P21-A, B, D, E, J, M, R, U, X. The control signal, NRZ VCC, is enabled by Q3, which activates the two head drivers, U96-10 and U96-14.

4-44. In the NRZI mode, an extra interface signal is required to write the longitudinal redundancy check character (LRCC) eight character spaces after the last data character. This signal is called Write Amplifier Reset (WAR \bar{S}) and enters the data board at P102-C. After propagating through U112-8, it is noise filtered by R258 and C112. The one-shot multivibrator, U115-4, outputs a negative 100-ns pulse to U114-3. This generates the clock for the write output registers. The WAR \bar{S} pulse also passes through U112-10 and U114-12 to give the signal, Clear Write Buffer (CLRWB). This pulse is applied to the Direct Clear inputs of the nine write input registers and sets them to a reference condition awaiting the next data character. The reference condition ensures erasure of the tape in the inter-record gap.

4-45. READ SECTION (Figure 4-7 and Sheet 2, Drawing No. 354040-300). The read section of the dual-mode data PWB consists of the following circuits:

- a. Nine read amplifiers (PE or NRZI).
- b. Signal threshold detection.
- c. Phase-encode envelope detection.
- d. NRZI Read Data strobe generation.
- e. Read output register.

4-46. The read section theory presented herein pertains specifically to the P channel but is applicable to all nine read channels. The first read amplifier (U80) has an approximate gain of 200, a bandwidth of 700 kHz, external frequency compensation, and no crossover distortion. The gain is set by R60 and R63, in the feedback circuit of the general-purpose 709 operational amplifier. The

read signal from the tape head is offset approximately -12 mV by the resistor divider network, R262 and R263. This is accomplished by connection of the center tap of the read head to this resistive divider. One end of the read head winding is left disconnected, and the other end is tied to the input of the amplifier. (The reason for offsetting the input is to eliminate the crossover distortion commonly present on the output of 709 operational amplifiers. This type of distortion cannot be tolerated in the reading of phase-encode data.) After amplification, the offset voltage will be approximately -2.5 volts. Capacitor C60 blocks the dc offset from the input of U33-3.

4-47. The second stage of amplification is a TL082, JFET, input operational amplifier whose characteristics include high input impedance, unity gain bandwidth, internal frequency compensation, continuous short-circuit protection, and low input bias and offset currents. The amplifier has a read gain potentiometer in the feedback circuit. The gain can vary from unity to 11 over a speed range of 12.5 to 125 ips, even with the different read heads. The higher the transport speed, the less the gain required. Therefore, with the lowest gain there will be the greatest bandwidth at 125 ips. High read gain and narrow bandwidth are needed for optimum performance at 12.5 ips. The adjustment of R203 through R211 is the only read gain adjustment for both PE and NRZI operation. This adjustment can best be made by writing all 1's at 800 bpi (NRZI), monitoring TP-30 through TP-38, and setting the signal level for 8 volts peak-to-peak.

4-48. The next stage, U33-7, is a low-pass, active filter. The low-pass elements are R62, R61, and the two capacitors, which change with speed, on header A6. Capacitor C59 and resistor R92 help to maintain a low-input offset voltage. The output of the low-pass filter goes to threshold detectors U27 and comparator U30-7. In the signal path to the comparator is a differentiator consisting of A6 (8-7) and R54. The signal path through R51 goes to the inputs of the dual-voltage comparator, type LM319. The other input to the U27 comparator is tied to the read threshold circuit.

4-49. Threshold detectors U27-7 and U27-12 each have a dc offset voltage tied to U27-10, which is TH-, and U27-4, which is the TH+, respectively. The two threshold voltages are set by U16 and associated circuitry (sheet 5 of the schematic). The read signal output of U33-7 is compared with the threshold reference, and when the positive read signal exceeds the threshold offset, U27-7 will go

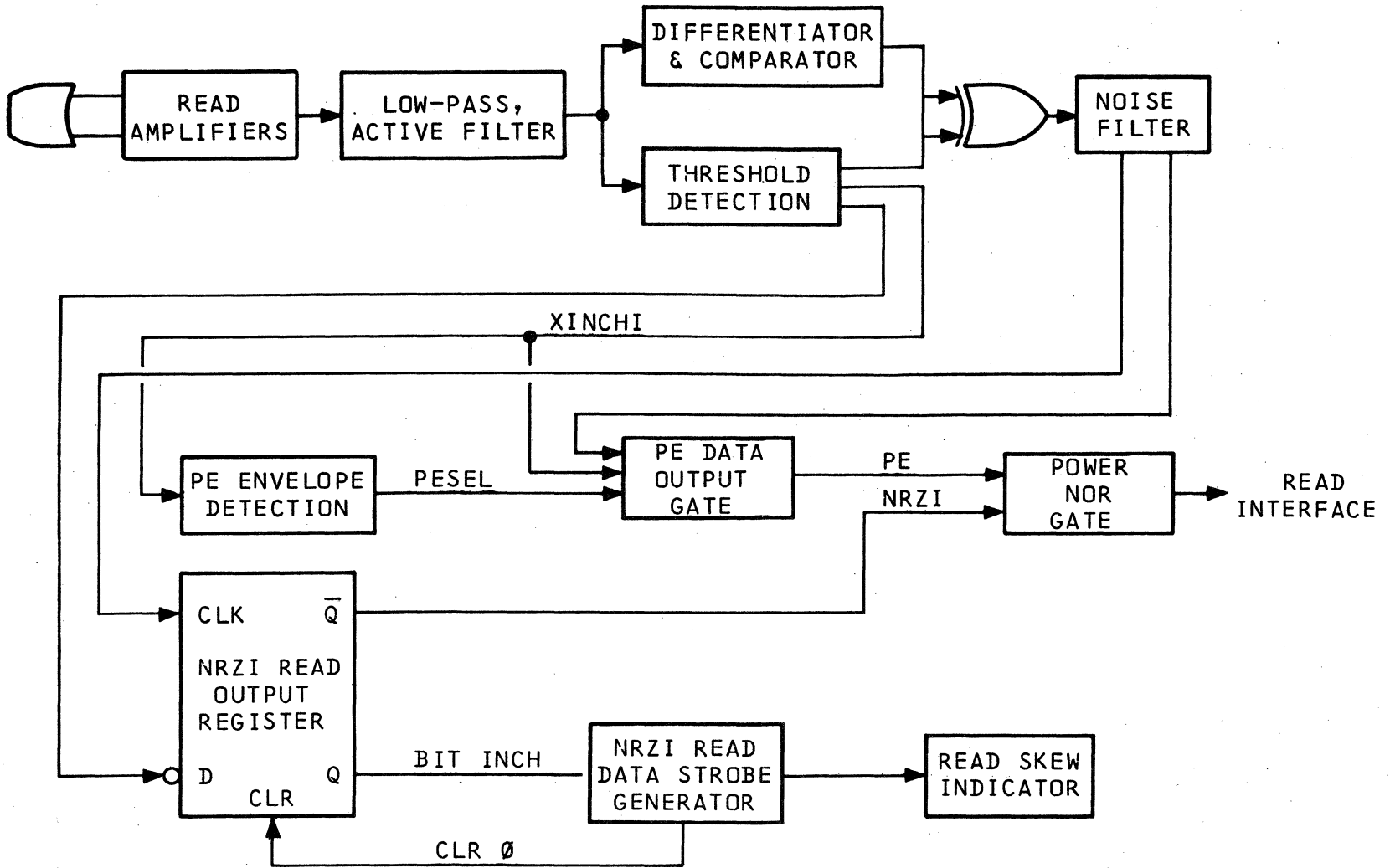

Figure 4-7. Read Data Block Diagram

high. If NRZI mode is selected, the high will be transferred as a low by U31-6. Exclusive OR-gate U37-3 has the input condition of U37-1, which is high, and U37-2 is the low when the read signal is a positive peak at U33-7. Thus, the output of U37-3 will be high.

4-50. If the read signal input to U27-9 is a negative peak, then U27-7 would stay low and the state at U37-2 would be high. Hence, the output at U37-3 would be low. The output of the exclusive OR-gate has the characteristic that the signal transition is in the same direction (negative-going) for both positive and negative peaks of the NRZI read signal.

4-51. The next group of components in the signal path consists of R45, A1 (1-14), and R39, which provide filtering action for the switching noise created by low-pass filter U30-7. The signal is inverted and delayed slightly before going to the clock input of U26-3, a D-type flip-flop. The initial condition of U26-6 is low.

4-52. Low true NOR gate U31-3 provides the D input to U26-2. Whenever data has been detected, U31-3 goes high. The signal goes through two inverters and is integrated by R43 and the capacitor on header A1 (7-8). Once the threshold of hysteresis gate U25-5 is reached, the input to D-type flip-flop U26-2 goes low. When the D-latch is clocked, output U26-6 goes high.

4-53. The interface, P103-1, is driven by a power buffer NOR-gate with open-collector output. When either input to U35 goes high, a low is transferred to the interface and interpreted as a 1 bit. The interface remains low until CLR0 clears flip-flop U26. When reading a 0 in the NRZI mode, the D flip-flop is clocked, but the D input, U26-2, is high. Hence, output U26-6 remains low, and the output of NOR gate U35-4 stays high. A high logic level at the interface is interpreted as a 0 bit.

4-54. AND gate U24-8 is used to pass the phase-encode data. The input, U24-9, is the control signal Phase Encode Select (PESEL), which is high true for PE operation. The other input, U24-10, is high when data has been detected in the channel. Low true NOR gate U31-3 goes high and is inverted by U28-12. Capacitor A1 (6-9) was initially charged to +5 volts. After about two bit cells of the preamble, A1 (6-9) is sufficiently discharged to cause U25-8 to go high. For a 1 bit, U24-11 will be high, and NOR

gate U35-4 will go low. Just the opposite is true for a 0 bit. The output of U25-8 is the channel envelope detect output for the PE mode, Data In Channel - Phase Encode (XINCHIP).

4-55. The nine-channel envelope detect signals go to U23-1 (sheet 5), an analog majority gate. The analog voltage is varied for some channels by the different resistor values on input U23-3. Channel P has a 10K-ohm resistor, R34, in series for detection of the identification burst. Note also that channels 3, 6, and 7 have 33K-ohm resistors in series with the input; thus, a file mark will enable the circuit also. U23-1 will slew to a positive level after two or three bits have passed through the read channels. This high is passed through some subsequent logic to give control signal PESEL, which enables AND gate U24-9 (sheet 1).

4-56. NRZI Read Gate and RDS Generation (Sheet 5, Drawing No. 354040-300). All nine channels generate a signal BITINCH (P-7), which means a NRZI 1 bit has been detected in the respective channel. The first channel to detect data will cause U4-9 to go high. U4 and U13 are configured as a latch, which is reset at CLR0 time. The high at U4-9 goes to the D input of U8-6. U8-9 is clocked by a signal generated from Y1, the crystal oscillator, and is 64 times the data rate in the NRZI mode. The high on the D input is transferred to the Q output, U8-7, at clock time. Note that U8 would be disabled when the data board is PE selected, because a low would be presented on the clear input, U8-1. In the NRZI mode, U8 is enabled. When the Q output is high, the two counters, U12 and U15, are allowed to start counting the clock pulses applied to their clock inputs. Prior to this, the counters are loaded with a set count. The operation of the switches on the lead inputs is as follows: both open, read gate = 12% of byte time; SW1 (1-16) open, SW1 (2-15) closed, read gate = 25% of byte time; SW1 (1-16) closed, SW1 (2-15) open, read gate = 37% of byte time; both closed, read gate = 50% of byte time.

4-57. When the carry output of U15-15 goes high, the next clock pulse will cause the D-type flip-flop, U8-15, to store this high. Two clock times then elapse before U5-12 goes low. On the third clock, U8-10 goes high and, with NRZI selected, U9-3 outputs the Read Data Strobe (RDS) to the formatter. The fourth clock time after U15-15 went high initiates CLR0, which clears the NRZI read output registers. At CLR0 time, the U4-9, U13-6 latch is reset. This latch will now wait for the next BITINCH signal to go true at the next byte time.

4-58. TEST SECTION. The test section of the dual-mode data board consists of the following circuits:

- a. Crystal oscillator.
- b. Two 16-bit counters.
- c. Read skew indicator.
- d. Switch settings.

4-59. With the Cipher dual-mode data PWB, it is possible to write all 1's on a tape without the use of external test equipment. There is a visual indication of out-of-tolerance read skew, and a variety of DIP switch settings is available to aid the technician in troubleshooting.

4-60. The test circuitry is shown on sheet 5, Drawing No. 354040-300. The crystal, Y1, supplies the clock for two counters, U11 and U7. Each counter contains four flip-flops and a divide-by-eight counter. When SW1 (3-14) is closed, the crystal oscillator frequency will be supplied to the NRZI Read Data Strobe generation circuit and to the divide-by-eight counter clock input, U11-1. When SW1 (4-13) is closed, the crystal frequency will be divided in half before application to the above circuits. Closing of SW1 (5-12) will provide the proper WDS frequency to test write 3200 fci for PE testing. Closing of SW1 (6-11) will provide the proper data rate to test write 800 fci for NRZI testing. When SW1 (8-9) is closed, the write head and erase bar current are enabled.



Closure of push button SW4 bypasses all file-protect circuits. To protect test tapes or other needed recorded data, ensure that this switch is open when tape erasure is not desired.

4-61. All tapes will be written with this SW-4 closed. This switch also provides control signal W TEST, which goes to the Direct Set inputs of the write input registers shown on sheet 1. The output of the write input registers is such that all 1's are written on the tape.

4-62. The clock for the write output registers is supplied by the output of the second counter, U7. The clock is passed through U10-4, U13-3, and U114-5 to generate CYCLE P.

4-63. Another feature of the dual-mode data board is the skew indicator. The one-shot multivibrator, U2, will detect a skew overflow. U2 fires whenever U18-5 goes high, and another BITINCH signal sets the U4-U13 latch after the latch has been reset by a high setting of U8-2. Deskewing of even just one channel will cause the LED indicator to illuminate.

4-64. Closing of SW1 (7-10) allows TP-10 to display the read skew waveform. This will show the read skew within 10% of a byte time for normal operation. The switch should be left open for NRZI operation.

4-65. CONTROL LOGIC STATE DECODER

4-66. The state decoder, U44, on the control/servo board, is a 3 to 8-bit decoder which provides transport status data to the various command control circuits in the control logic. These transport configuration levels are used to enable and disable gates in the transport's control logic, thus maintaining the proper sequence of commands and preventing improper commands.

4-67. There are eight outputs, representing eight possible logic configurations, one of which must be low at all times (Figure 4-8). Three inputs to the decoder determine its output state. These inputs are received from the Q outputs of three J-K flip-flops: U38B, U38A, and U39A. These low or high values are the same as those present on the J inputs of the flip-flops immediately before the clock pulse is received from U46B. The transfer of these values is triggered by the low-going edge of the clock pulse. The decoder maintains each state until the next one is clocked in.

4-68. STATE 0, STANDBY. This is the initial state that follows the application of power to the transport as well as the reset state. The power-on reset circuit of Q12 and Q13 works in conjunction with C5 and R5 on the power supply board to delay the resetting of the J-K flip-flops until all other logic circuits are stable. The power-on Reset line to U43B goes low, causing a low to be supplied via U37E to the Direct Clear inputs on the three J-K flip-flops, U38B, U38A, and U39A. This causes their Q outputs to go low, which sets the decoder to the standby state. U43B can also be triggered to produce a RESET command by a broken tape or by tripping of the compliance arm limit switches.

4-69. STATE 1, STOP. This state results from the first action of the LOAD control (A2) on the front

panel. The servo system and drive motors are energized, causing the tape to be tensioned, but motion commands are not enabled. See Figure 4-9.

4-70. The state decoder's digital 4 and 2 inputs remain at 0, as originally set in the standby state. All inputs to U29C and U43A remain high.

4-71. Since the BOT and Load inputs to U23C are not true, the level of U23C into U29A is high. The Rewind level into U29A is also high. Since the logic is in the standby state, the standby level is true, or low. This low input to U29A causes its output to be high and makes the J input of U38B high. Actuation of the LOAD control (A2) triggers the internal logic clock pulse generator (U46B), causing the high to be transferred from the J input to the Q output of U38B. In this manner, the digital 1 input of the state decoder is set to 1. This binary code (001) is the stop state and causes the Stop line to become true.

U46A is triggered and provides an inhibit pulse, allowing the retractor time to get to the down position.

4-72. STATE 2, LOAD. Actuation of the LOAD control a second time starts the tape moving forward to the load point. When the BOT tab is sensed by the photosensor assembly, tape motion ceases and the transport enters the ready state.

4-73. The state decoder's digital 4 input remains at 0 as originally set in the standby state. Actuation of the LOAD control while the transport is in the stop state causes the LOAD control input to U43A to go low. Since the other three inputs remain high, the output of U43A goes high. This is applied to the J input of U38A, where it is stored as a binary 1 until the flip-flop is clocked. This will become the digital 2 input to the state decoder.

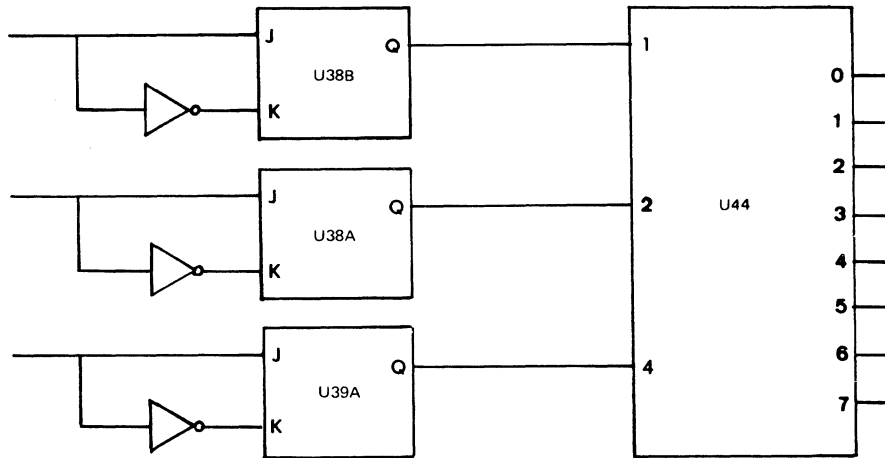

INPUTS			OUTPUT STATE	NAME
4	2	1		
0	0	0	0	STANDBY
0	0	1	1	STOP
0	1	0	2	LOAD
0	1	1	3	READY
1	0	0	4	REWIND
1	0	1	5	DELAY
1	1	0	6	UNLOAD
1	1	1	7	RESET

Figure 4-8. State Decoder

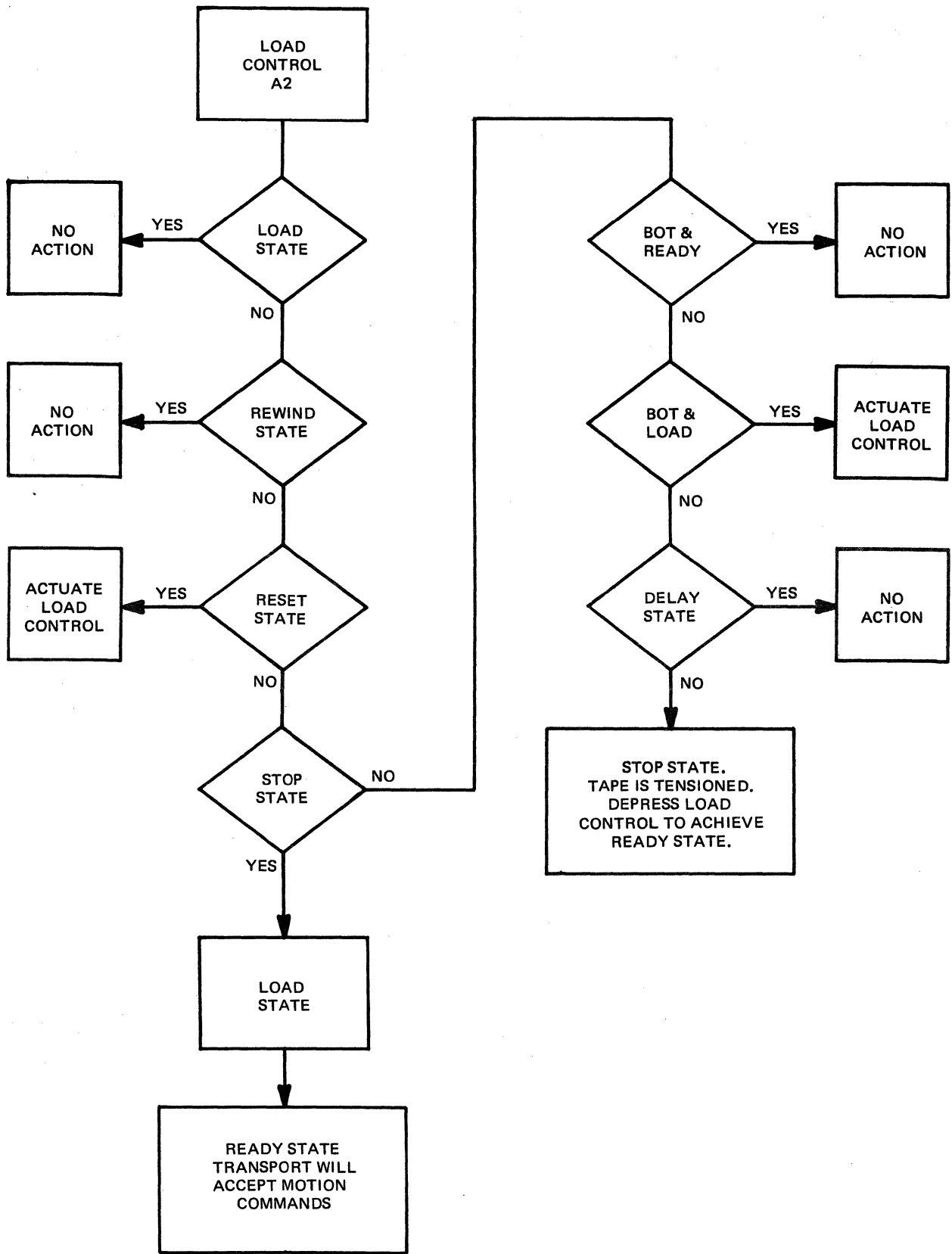

Figure 4-9. Load Sequence Flow Chart

4-74. The three inputs to U29A are high, causing its output to be low. This low is applied to the J input of U38B, where it is stored as a binary 0 until clocking. This will be the digital 1 input to the state decoder. Actuation of the LOAD control also triggers the internal logic clock pulse generator, which introduces a slight delay to allow for loading of the J-K flip-flops. The clock pulse transfers the binary code stored at the J inputs to the Q outputs of the J-K flip-flops, where they serve to set the state decoder. This binary code (010) is the load state, which causes the Load line to become true.

4-75. STATE 3, READY. Sensing of the BOT tab during the load sequence places the transport in the ready state. The logic circuitry can now accept both local and remote motion commands when other criteria are met. (See paragraphs 4-91 through 4-107.)

4-76. When the BOT tab is sensed during the load sequence, the BOT line becomes true and is applied to U23C as a high level. The load level is inverted by U23D and is also applied to U23C as a high level. With these two inputs high, the output of U23C goes low and is applied to U29A. Because the transport is not in the standby or rewind state, the remaining inputs are high. Thus, the output of U29A goes high and is applied to the J input of U38B to await clocking. This is the digital 1 input to the state decoder. The digital 2 and 4 inputs remain the same as in the load state.

4-77. The internal logic clock pulse generator is triggered by the output of U40C, which goes low when the BOT tab is sensed. The state decoder is now in the ready state (binary code 011).

4-78. STATE 4, REWIND. Either a remote or local REWIND command rewinds the tape onto the supply reel until the BOT tab is sensed. At this point, the decoder cycles through the delay and load states to the ready state. Actuation of the local REWIND control (A4) will then unload the tape.

4-79. The remote REWIND command gate, U6C, requires the transport to be on line, selected, in the ready state, and not at BOT. The low output of U6C is used to actuate U30D, which triggers the internal logic clock pulse generator, U46B. This, in turn, clocks the J-K flip-flops controlling the state decoder, U44.

4-80. The local rewind control gate, U20C, requires the transport to be off line and in either the stop, ready, or load state. The low output of U20C also actuates U30D and clocks the J-K flip-flops, as in the remote sequence.

4-81. The state decoder's digital 4 input is a binary 1 during rewind, since two of the inputs to U29C are held high and the Rewind input is switched low. All inputs to U43A and U29A are held high, resulting in presentation of a binary 0 to the state decoder's digital 2 and digital 1 inputs. This binary code 100 represents the rewind state.

4-82. STATE 5, DELAY. The transport continues to rewind tape onto the supply reel until the BOT tab is sensed. At this point, the BOT lines go true, changing the state decoder input to binary 101, the delay state. This delay allows the transport to come to a complete stop before a new motion command is accepted.

4-83. With the Delay lines true, the state decoder input becomes binary 010, the load state. With the Load lines true the binary code becomes 011, the ready state. The transport will now accept motion commands. Actuation of the REWIND control at this time unloads the tape.

4-84. STATE 6, UNLOAD. With the transport in the ready state, actuation of the REWIND control changes the state decoder's binary input to 110, the unload state. When the last of the leader has passed through the photosensor, both the BOT and EOT sensors are activated. These two signals are ANDed at U22C and used to actuate the reset gate, U43B. This Reset pulse is applied to the Direct Clear inputs of the three state decoder flip-flops, setting their Q outputs low. This forms the binary code 000, returning the transport to the standby state.

4-85. STATE 7, RESET. A logic error creating an undefined state in which binary code 111 is presented to the state decoder results in the reset state. The Reset line goes low, actuating the reset gate, U43B. The high output of U43B is inverted by U37E and routed to the Direct Clear inputs of the three state decoder flip-flops, U39A, U38A, and U38B. This makes their Q outputs low, forming a binary 000 input to the decoder and returning the logic to the standby state.

4-86. The high output of U43B is also inverted by U37F and used to disable transistor Q16. When Q16 is turned off, the ground normally supplied to the reel motor relay, K2 (on the reel servo portion of the control/servo board), is removed. When K2 is deenergized, both reel motors are placed in their dynamic braking states, and the motors are maintained in a deenergized condition until a new command is issued. In addition, if the transport is in the on-line mode, initiation of the reset state will return it to the off-line mode.

4-87. COMMAND LOGIC

4-88. There are two methods of commanding transport operation: manually, by means of the front panel controls, when the transport is in the off-line mode; and remotely, when the transport is in the on-line mode and is being controlled by computer-generated signals. A J-K flip-flop, U39B, determines the on-line status of the transport. See Figure 4-10.

4-89. The external OFF LINE command, applied at J101-L and enabled by the Select and Ready levels at NAND gate U12D, sets the on-line/off-line flip-flop, U39B, to the off-line state. This OFF LINE command is applied to U39B as a Direct Clear reset. When low, U39B is effectively locked in the off-line mode, and the front panel control (A3) will have no effect.

4-90. The ON LINE control/indicator (A3) provides a clock pulse to U39B, which is gated through U12A when the system is not in the standby mode. In switching from the off-line to the on-line mode, the high level appearing on the off-line circuit and connected to the J input of U39B is transferred across to the Q output when the clock pulse is received, thus making the on-line circuit high. In switching from on-line to off-line, the low level appearing on the off-line circuit is transferred from the J input to the Q output when U39B is clocked, thus making the on-line circuit low.

4-91. FORWARD COMMAND CIRCUIT

4-92. Forward tape motion may be commanded by the FORWARD pushbutton on the local control panel when the transport is in the off-line status. Forward tape motion may also be commanded remotely, through the interface, when the transport is on-line. NOR gate U41B is the link between these two control sources (Figure 4-11).

4-93. REMOTE FORWARD COMMAND. The remote FORWARD command is a low level applied to pin C of J101. U1, pin 9, and U2, pin 6, supply a positive collector voltage to this line for the user's output device. Inverter U4B inverts the negative logic input to provide a high true to the two-input NAND gate, U14B. The second high input required by U14B is the Command Gate Enable level derived from the three-input NAND gate, U6A. U6A requires all three inputs to be high: the On-Line level from U39B, the Ready level from state decoder U44, and the Select level from U21C. When these conditions are met, the output of U6A goes low. This low level is inverted by U4A and fed to U14B, thus enabling it. The low true output of U14B is routed to the two-input NOR gates, U41B and U8D.

4-94. The low input to U8D causes its output to go high and trigger the monostable multivibrator, U48. U48 is used to clock the overwrite and write enable flip-flops, U16A and B. The low input to NOR gate U41B causes its output to be high. This high is the true condition of the FORWARD command level and is discussed further following the description of local FORWARD command.

4-95. LOCAL FORWARD COMMAND. The switch portion of alternate-action pushbutton/indicator A7 applies a high, when actuated, to NAND gate U25B. U25B requires two additional inputs to be high: the Ready level from the state decoder (U44) and the Off-Line level from J-K flip-flop U39B. When these conditions are met, the output of U25B goes low, the true state. U31F inverts this level and applies it as a true high input to the two-input NAND gate, U41A. If the EOT output of U22D is also high, the output of U41A becomes true and is applied to NOR gate U41B as a low, thus enabling it.

4-96. The true output of U41B is high. This high level is applied to NAND gate U50A. If the reverse level applied to inverter U49A is low (false), its output becomes high and enables U50A. This command redundancy prevents issuance of simultaneous commands for both FORWARD and REVERSE. The low output of U50A or U50B generates the Forward (Reverse) and Run signals, respectively, that control the capstan drive logic.

4-97. CAPSTAN DRIVER. The Forward and Run signals are ANDed at U303B on the capstan driver portion of the circuitry. The low (true) output of U303B is inverted by U304A and used to activate the forward switch driver, Q309. This, in turn, activates the forward switch, Q301. A positive reference voltage is provided by zener diode CR301. This reference is stabilized at 6.2 volts by the amplifier circuit of U301A. The positive 6.2-volt output of U301A is routed to the inverting input of U301B to provide the negative reference level for the reverse and rewind circuits. This positive output is also routed through the forward speed adjust potentiometer, R312, and the forward switch, Q301, to the inverting input of U305A. (See Figure 4-12.) Amplifier U305A serves to isolate the forward/reverse command circuit from the ramp-shaping circuit. Its output is a negative voltage level for the forward mode and is routed through the ramp adjust potentiometer, R333, to switch Q312. Q311, the rewind switch, is off during forward and reverse operation.

4-98. Switch Q312 is controlled by the flip-flop circuit of U302C and D. With the Run input true

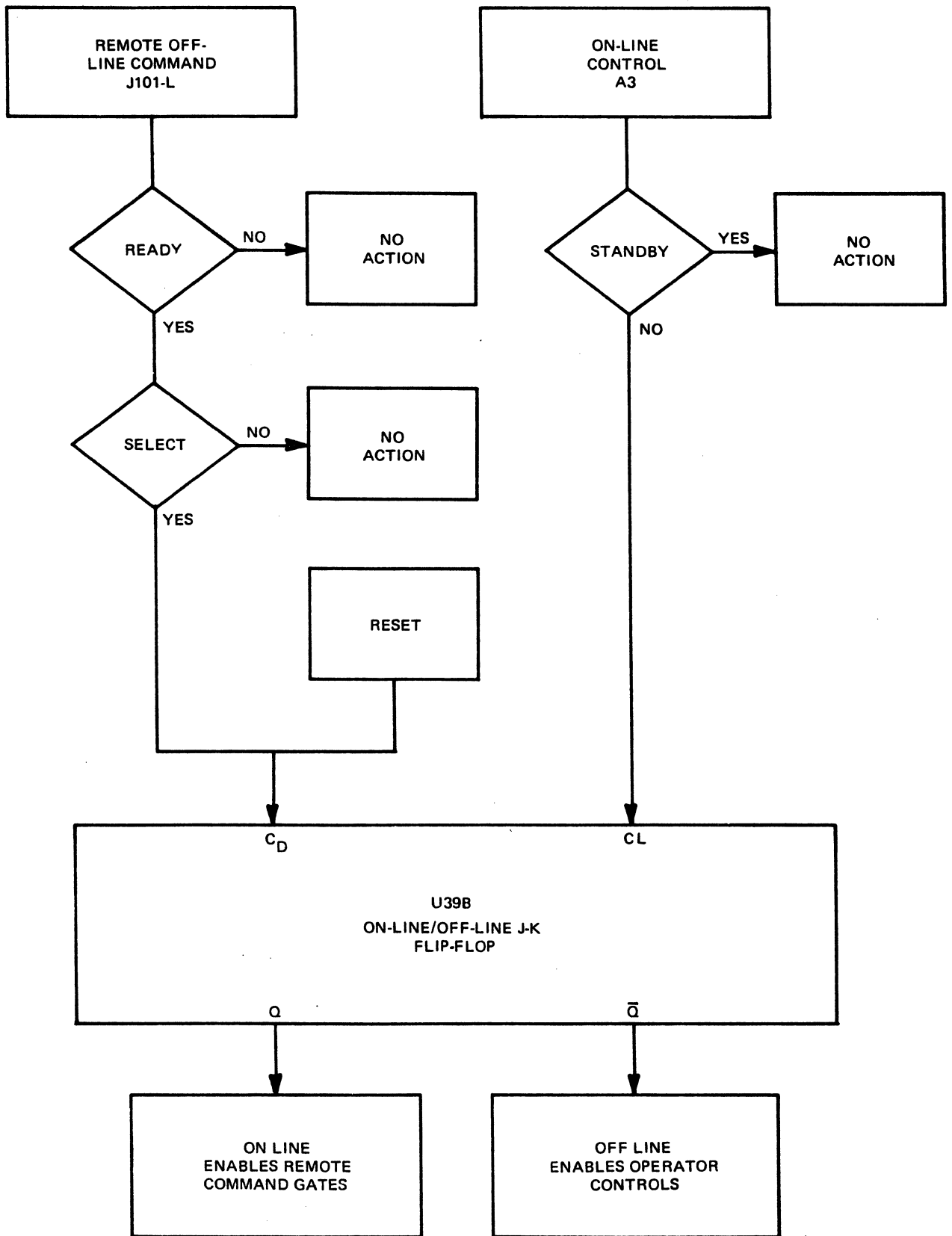

Figure 4-10. Local/Remote Operation Flow Chart

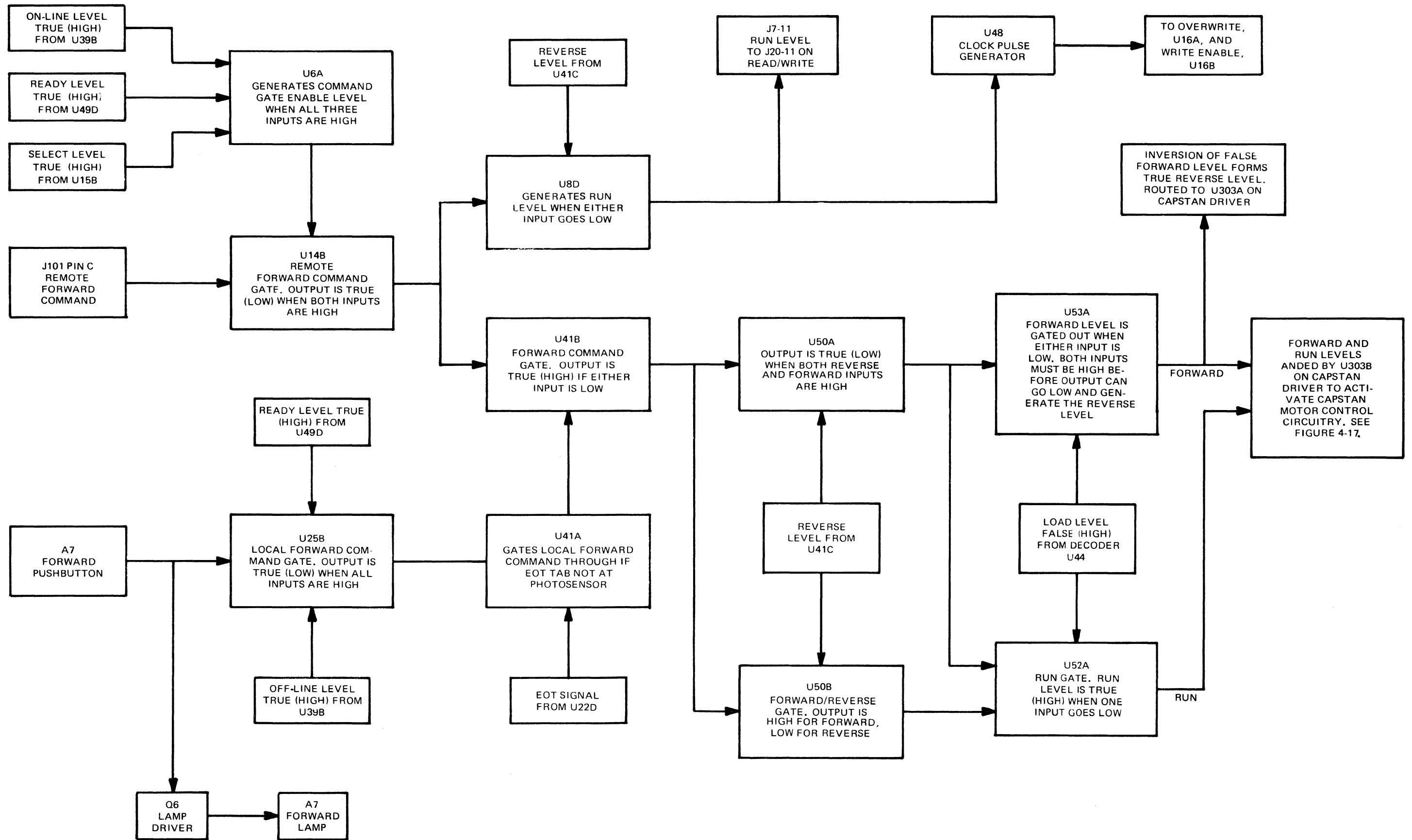

Figure 4-11. Forward Command Logic Block Diagram

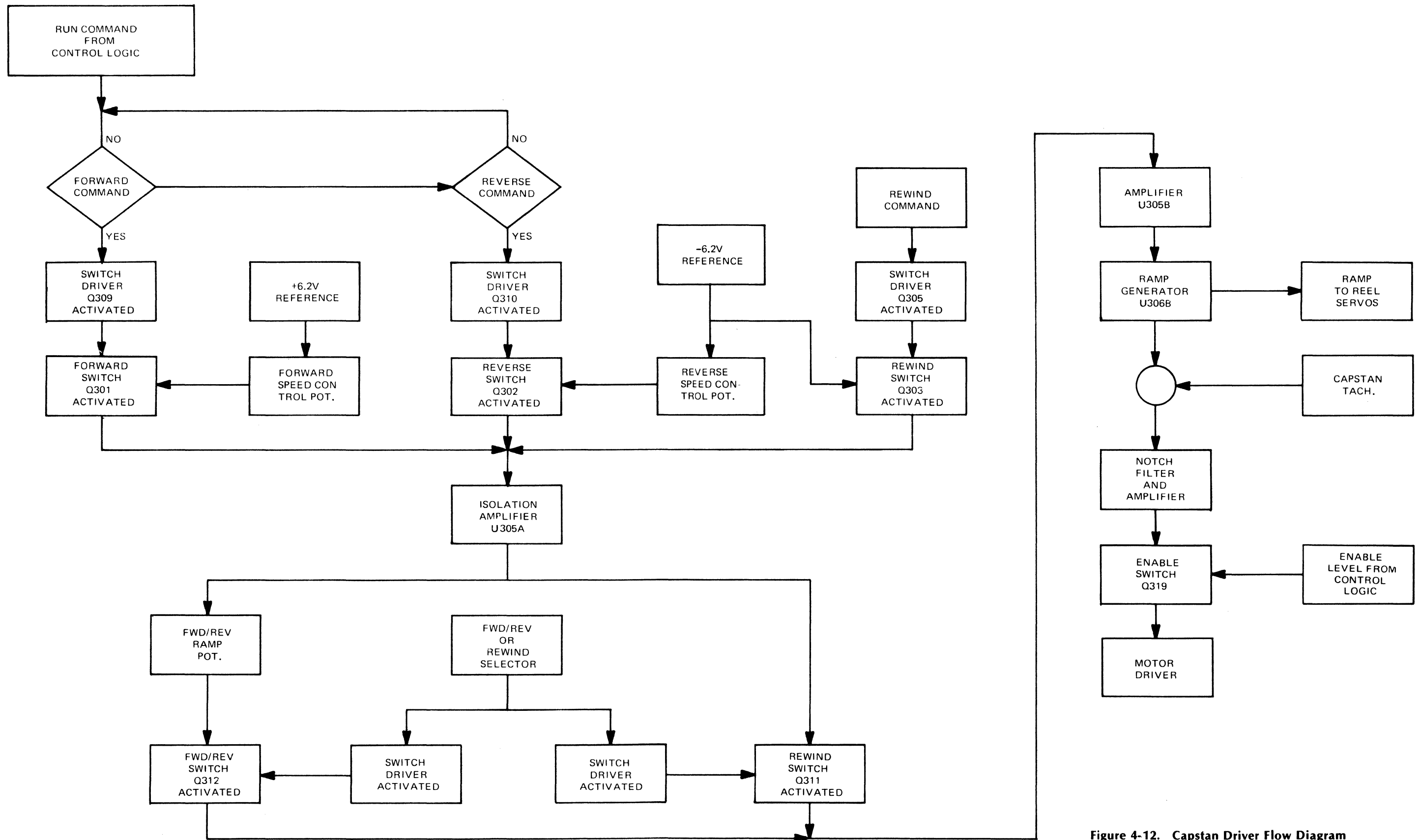

Figure 4-12. Capstan Driver Flow Diagram

(high) and the $\overline{\text{Rewind}}$ input false (high), the output of the flip-flop at U302D is low. This low is inverted by U304B and used to activate switch driver Q307, which, in turn, activates switch Q312. The output of Q312 is applied to the inverting input of gain-determining amplifier U305B. The output of U305B is then applied to the inverting input of amplifier U306B. U306B and its associated circuitry form the ramp generator. Feedback capacitor C315, together with ramp adjust potentiometer R333, determine ramp time. The output of U306B (TP302) is negative for the forward mode. This ramp generator output is routed to the reel servo loops to initiate the response of the supply and takeup reels.

4-99. The ramp level is summed with the output of the tachometer (TP301), and the resulting error voltage is applied to the inverting input of amplifier U306A. The output of U306A is fed through a notch filter network to U307B, where it is again inverted. Feedback from the power driver is routed through a compensation network consisting of R353, R382, and C314 and summed with the notch filter input to U307B. The enable switch, Q319, determines whether or not the capstan motor can be driven. Q319 is a FET switch controlled by the Enable line from the control logic circuitry. When the Enable line is at 0 volts the switch is on, and the input to the motor driver from U307B is shunted to ground. When the Enable line is at -15 volts, the switch is off and the motor driver can be activated.

4-100. The output of U307B is a negative voltage level for forward motion. This negative level activates the capstan motor forward driver circuitry consisting of Q316, Q317, and Q318, which applies negative power through J9 to the capstan motor, resulting in forward tape motion. The power driver output is also routed through an amplifier, U307A, and a bridge rectifier with a 6.8-volt zener diode to provide current-limiting feedback.

4-101. REVERSE COMMAND CIRCUIT. Reverse tape motion may be commanded by the REVERSE pushbutton on the local control panel when the transport is in the off-line mode or remotely when the transport is on line. U41C functions as the link between these two control sources in the same manner as U41B operates in the FORWARD command circuitry (Figure 4-11). The control logic used for the reverse mode is similar to that previously described for the FORWARD command path. The true (high) output of U41C is inverted by U49A and applied to NAND gate U50A. This low input to U50A drives its output high, providing the high Reverse level required by the capstan driver.

4-102. The Reverse and Run signals are ANDed at U303A in the capstan driver, inverted by U304D, and used to activate switch driver Q310. Q310, in turn, turns on the reverse switch, Q302. This applies the negative reference level from U301B, as set by the reverse speed adjust potentiometer, R307, to U305A. The remaining circuitry functions in the same manner as in the forward mode, with the exception that the voltage output of each state is of opposite polarity. The input to the motor driver from U307B is a positive voltage level for reverse operation. This activates the reverse motor driver circuitry of Q315, Q313, and Q314, which applies positive power through J9 to the capstan motor, resulting in reverse tape motion.

4-103. REWIND COMMAND CIRCUIT. The rewind mode may be commanded by the REWIND pushbutton on the local control panel when the transport is off line. Rewind may also be commanded remotely when the transport is on line. U30D in the control logic is the link between these two control sources. The output of U30D is used to trigger the internal control logic clock pulse generator, U46B, which clocks the rewind state into the decoder, U44. See the description of the rewind state under paragraph 4-78.

4-104. The true $\overline{\text{Rewind}}$ input to U50C causes its output to go high. This high is inverted by U49F and routed to the capstan driver as the $\overline{\text{RWD}}$ level. The low output of U49F is also applied to U52C, causing its output to go high and activate switch Q15. Q15 then turns on switch driver Q104, on the power supply, which activates switch Q103. Q103 applies +36 volts to the reel motor power input line, which provides the high rewind speed.

4-105. The low $\overline{\text{RWD}}$ input into the capstan driver is inverted by U304E and turns on switch driver Q305, which activates the rewind switch, Q303. Q303 then passes the negative reference voltage from U301B to the input of U305A. Fixed resistor R309 determines the rewind speed. The output of U305A is a positive level for rewind operation and is routed through Q311 when it is activated by switch driver Q308.

4-106. The low $\overline{\text{RWD}}$ input from the control logic circuit is applied to U302A and inverted by U304F to turn off the stop mode offset switch, Q304. $\overline{\text{RWD}}$ is also applied to U302D, making its output high. When inverted by U304B, this output turns off the forward/reverse switch, Q312. The high output of U302D is applied as an input to U302C. The low Run level from the control logic is inverted by U302B and becomes the second high input into U302C. With both inputs high, the output of U302C becomes low and activates switch driver Q308 after inversion by U304C.

4-107. With rewind switch Q311 turned on, the positive Rewind level is transferred to the inverting input of U305B. The ramp generator, notch filter, and motor driver circuits operate in the same manner for rewind as they do in forward. The takeup and supply reel servos also operate in the same manner as they do in the forward mode. The reel motor supply voltage is increased to 36 volts, however, to provide a faster rewind speed.

4-108. REEL SERVOS

4-109 The supply and takeup reel servos use similar circuitry and operate in the same manner (Figure 4-13). The following circuit description pertains to the supply servo but can be applied to the takeup servo as well. The last two digits of the reference designators are the same for each servo. The first digit, however, is a 2 (i.e., 2xx) for the supply servo and a 4 (i.e., 4xx) for the takeup servo.

4-110. COMPLIANCE ARM POSITION SENSOR. The reel motor is controlled by the photosensor assembly (Figure 4-14), which varies the current input to U201A as a function of compliance arm position. The photosensor assembly consists of a lamp, a solar cell, and a slotted disc. The disc is attached to the compliance arm spindle and rotates with it, acting as a rotary shutter to vary the amount of light falling on the solar cell. This changes the current flow through the photo diode, which changes the input to amplifier U201A.

4-111. The photosensor lamp is supplied with positive current through lamp driver Q201. Q201 is controlled by the base current applied by amplifier U201B. The output of U201B is controlled by the negative voltage level set by the compliance arm position adjust potentiometer, R202. The source of this voltage level is the negative reference voltage supplied by U301B on the capstan driver portion of the circuitry. Adjustment of R202 varies lamp intensity, which changes the solar cell current input to U201A and causes the servo system to change the compliance arm position. This adjustment is used to center the arm in its arc of travel. (See Section V.)

4-112. As tape is taken from or added to the compliance system by the capstan drive, the compliance arms move to maintain tape tension. This movement is detected by the photosensor assembly, resulting in a change of the current input to U201A. The output of U201A is applied to the inverting input of amplifier U202B. The ramp level from U306B on the capstan driver is applied to the positive input of U202B. This input is negative for the forward mode and positive for reverse. The

ramp serves as a prestart signal to initiate reel motion in the required direction prior to the compliance arm motion sensor's command, during stop and start operations. This prestart increases the amount of effective compliance provided by the system.

4-113. The Enable level from the control logic circuitry is required to be at -15 volts for the FET switch, Q208, to be off and not ground the motor driver input. This requires that the system not be in a standby and that the retraction arm be in its down position (down switch closed). The output of U202B is a negative voltage for forward motion and positive for reverse. When negative, transistors Q205, Q206, and Q207 are turned on, supplying a negative voltage to the motor and resulting in clockwise reel motion (forward mode). When positive, transistors Q204, Q202, and Q203 are turned on, supplying a positive voltage to the motor and resulting in counterclockwise reel motion (reverse mode). Power for the supply and takeup reel motors is supplied through the contacts of relay K2. Relay K2 is energized when the ground side of the coil circuit is completed through transistor Q16 in the control logic circuit. Q16 is on when the logic is not in a standby mode.

4-114. A limit switch, actuated by two nylon screws on the compliance arm, determines the maximum travel of the arm. When the switch is actuated, the output of U52B of the control logic is routed to the reset gate, U43B. If the system is not in the stop or standby mode, the control logic will be reset. The reset condition turns Q16 off, deenergizing K2. In the deenergized state, the supply reel motor inputs are connected directly together, while the takeup reel motor inputs are connected through a current-limiting resistor, R436. This arrangement provides the transport with a dynamic braking action whenever power is lost or a reset occurs for some other reason. (See description of reset state, paragraph 4-85.)

4-115. Current-limiting feedback is provided through amplifier U202A and the bridge rectifier and zener diode network, CR204 through CR208. This feedback is taken from the motor power return line and is inserted at the input to the motor driver circuit (bases of Q204 and Q205).

4-116. RETRACTOR OPERATION (Figure 4-15). With power on and tape under the EOT/BOT sensor, a high level appears at the output of U22C. This output is applied at the input of U53D. If the down limit switch is energized, no action will result. If the down limit switch is not energized, the retractor arm will be driven up.

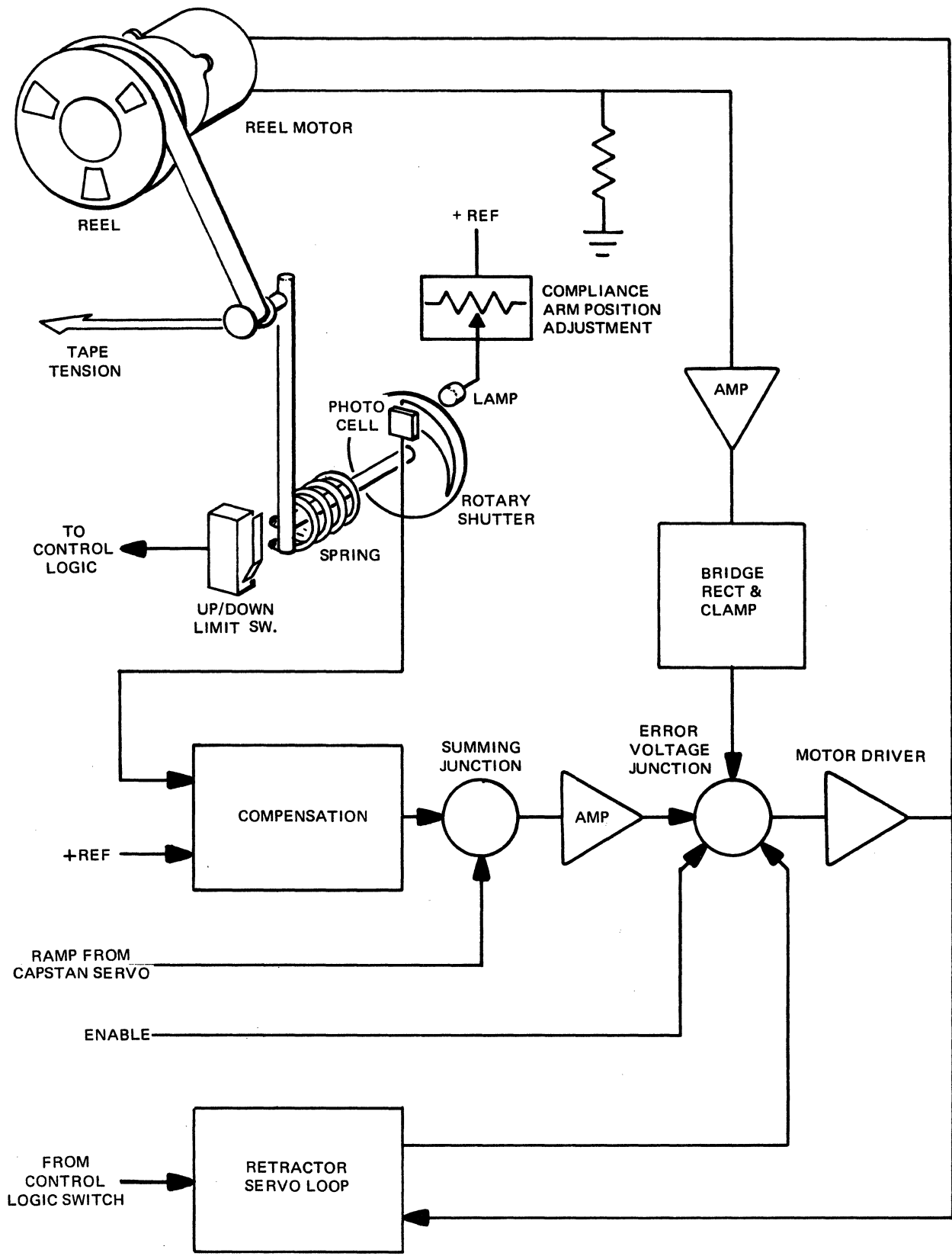
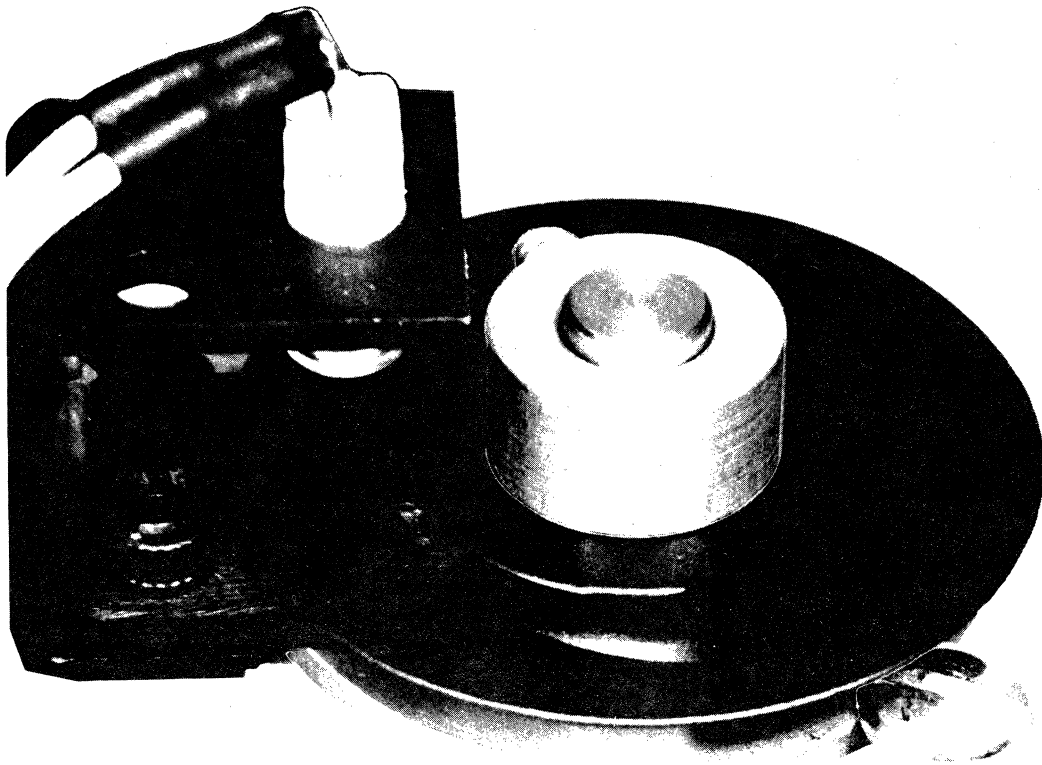
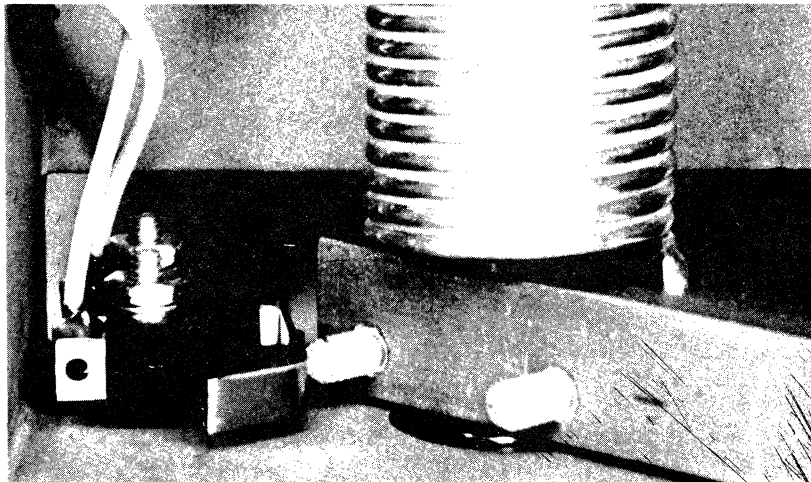

Figure 4-13. Reel Servo Block Diagram



MOTION SENSOR



LIMIT SWITCH

Figure 4-14. Compliance Arm Motion Sensor Assembly and Limit Switch

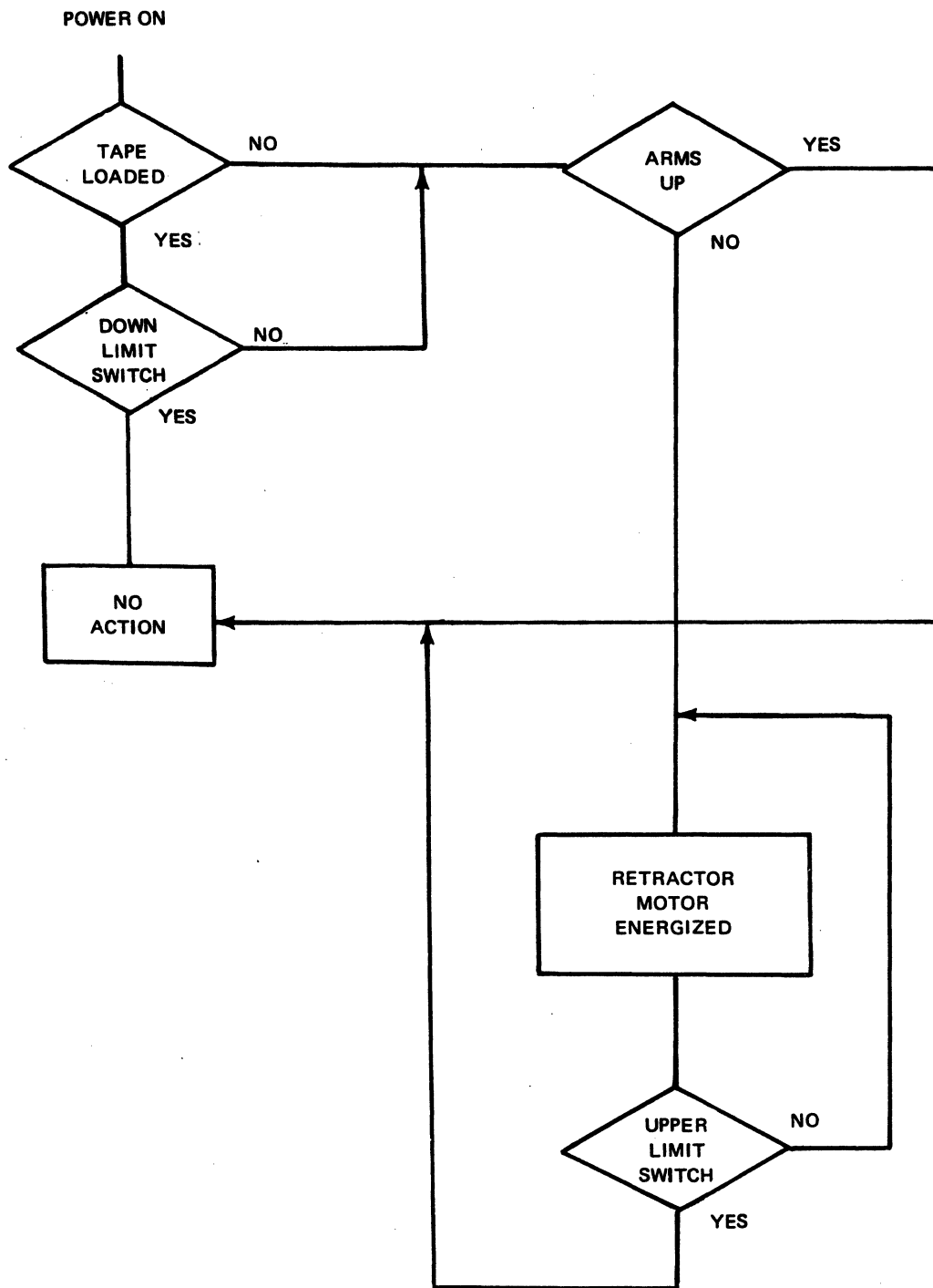

Figure 4-15. Retractor Flow Chart

4-117. If the tape is not under the EOT/BOT sensor and the up limit switch is closed, there will be no action. If the up limit switch is not closed, the retractor arm will be driven up. Figure 4-16 is a timing diagram of retractor operation.

4-118. WRITE PROTECT CIRCUIT

4-119. Write protection is provided by switch S9. When a supply reel with no write ring is mounted, S9 remains closed. This switch closure presents a false input to U15A, pin 5, causing U16A to be held in a reset state and preventing the transport from going into the write mode.

4-120. A solenoid attached to S9 retracts the switch plunger when a write ring is sensed to prevent rubbing. The solenoid is energized, whenever a write ring is sensed and the transport is not in the standby state, by U8A, U8B, Q9, and Q10. U7 is a one-shot which maintains the solenoid in an energized state for 5 seconds after the transport enters the standby state during unloading in order to prevent the switch plunger from coming into contact with the moving reel.

4-121. LOGIC OPTIONS

4-122. Various logic options are available in the Model 100X transport. These options are selected by jumpers soldered into the control/servo board (Table 4-2). These optional logic configurations will be wired in at the factory as the customer requests.

4-123. AUTOMATIC POWER-RESTORATION OPTION. As indicated in Table 4-2, installation of jumper $\bar{T} - \bar{U}$ on the control/servo PWB causes the transport to retension the tape and go on line automatically upon restoration of input power following a power outage. Upon restoration of power to the transport, U43B-13 goes to +5 volts following a time delay determined by the power reset circuitry. Unless a broken tape is indicated by the EOT/BOT sensor, U38B-8 also goes to +5 volts at the same time. U3-3 then goes true (+3.8 volts) for a period of time determined by R82 and C47 (approximately 1 second).

4-124. At this time, U52B-6 is true (+5 volts), since the transport is in standby mode. U10-13 goes low (0 volts), forcing U38B and U38A both to go set,

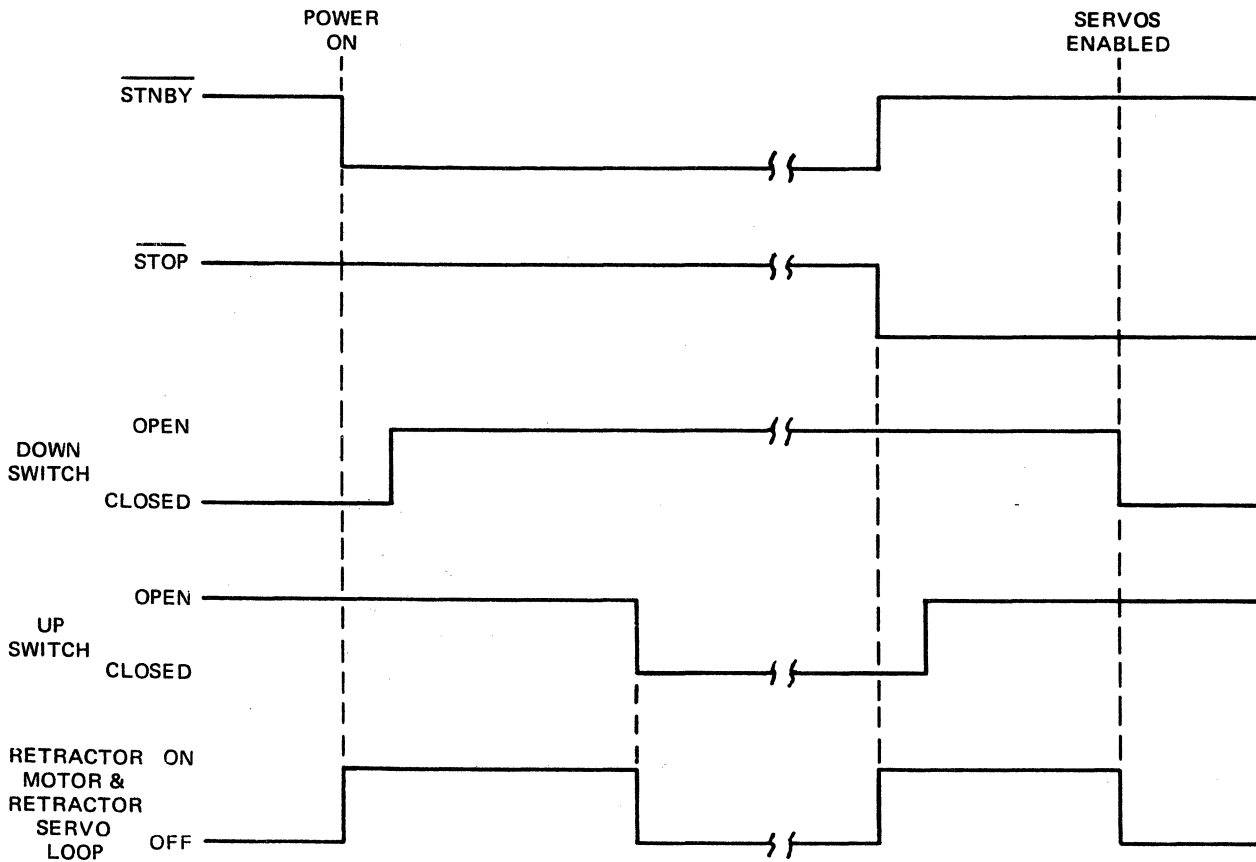

Figure 4-16. Retractor Motor Timing Diagram

FUNCTION	JUMPER	PURPOSE
Status Indications	A to B	When installed, provides status indications to interface when transport is on line and selected. When not installed, status indications are provided whenever transport is selected.
Local/Remote Density Select	E to F	Strapped to PE mode. Indicator always illuminated.
	C to F	Manual mode selection. (See Table 3-1.)
	D to F	Mode selection by computer.
	No Jumper	NRZI mode. Indicator extinguished.
Overwrite	G to H	Installed with overwrite option. Note write reset jumper on read/write board.
On line/Ready	J to K	When installed, depression of ON LINE pushbutton will force ready status in middle of tape.
Rewind/Off Line	L to M	When installed, will cause unit to revert to off-line status when rewind is commanded remotely.
+5V Supply	DIODE N to P	Diode can be installed (cathode to N, anode to P) to provide +5 volts for customer's terminators.
Write Enable	S to T	Normal configuration: Write Enable line is sampled and stored 20 microseconds after RUN command is given. Output of stored signal becomes Read/Write signal to read/write board.
	R to T	Read/Write signal is controlled directly from Write Enable line.
Rewind/Ready	U to W	Ready signal sets rewind status.
	U to V	Rewind status resets before Ready.
Automatic Power Restore	\bar{T} to \bar{U}	Transport retensions tape and goes on line when power restored after outage.

Table 4-2. Control/Servo Board Logic Options

which is the ready state. This condition forces the tape to be tensioned and triggers one-shot U46A. If tensioning is accomplished, the timeout of U46A forces a pulse on U19E-11, placing the transport on line. If no tape is mounted on the drive, U3 will time out without accomplishing the tape-tensioning function, and no further attempt will be made.

4-125. POWER SUPPLY

4-126. If power source voltage is other than 115 Vac, transformer T1 is to be connected in accordance with Table 2-1. Referring to Section VII, Drawing No. 331530-300, the input power to the power supply is filtered by filter F1. The ac voltage is then routed through J18 to the POWER switch on the front panel and then through J19 to the primary of transformer T1.

4-127. The four secondary outputs of T1 are rectified by fullwave diode bridges CR1, CR2; CR3 through CR6; CR7 through CR10; and CR11. The +36 and -36-volt supplies are rectified by CR1,

the +36-volt output being filtered by C4 and C1 and the -36-volt output by C3 and C2. The +14-volt and -14-volt supplies are rectified by CR2, the +14-volt output being filtered by C1 and the -14-volt output by C2. The +15-volt supply is rectified by CR3 through CR6 and filtered by C6, and the -15-volt supply is rectified by CR7 through CR10 and filtered by C7. The 5-volt unregulated supply is rectified by CR11 and filtered by C8. CR21 and C5 provide the power-on RESET command to the control/servo board.

4-128. The circuit consisting of CR15 through CR19 and K1 controls the voltage applied to the compliance arm retractor motor. To ensure proper voltage, terminals on the power supply PWB designated 5 and 6 are connected to terminals 8 and 5, respectively, of transformer T1. This provides 125 Vac at pins 2 and 3 of J17 when pin 11 of J15 is grounded, even when T1 is wired for other than 125 Vac.

4-129. The regulators for the power supply are contained on the control/servo board.

SECTION V MAINTENANCE

5.1. GENERAL

5.2. This section contains periodic maintenance information, removal and replacement instructions, and adjustment procedures. Table 5-1 presents the preventive maintenance schedule. Refer to Section VII for schematic diagrams, assembly drawings, and parts list.

CAUTION

If transport is to be swung out from equipment rack on hinges for maintenance operations, ensure that rack is mounted securely. Weight of transport in open position could upset an inadequately mounted equipment rack.

5-3. CLEANING

NOTE

Items needed for cleaning are available as Cipher Part No. 960855-001, Tape Drive Cleaning Kit.

5-4. CAPSTAN. Wipe the capstan gently, using a lint-free cloth saturated with tape-drive cleaner. If the capstan is excessively dirty with tape oxide/binder deposits, it may be cleaned with a solvent-resistant swab slightly moistened with tape-drive cleaner.

CAUTION

Do not clean capstan with motor running. Do not use head cleaner, Freon flux remover, alcohol, or other solvents to clean capstan sleeves.

5.5. HEAD AND GUIDES. Clean the head, its associated guides, and the roller guides with a lint-free cloth or a swab moistened with tape-driver cleaner.

CAUTION

Use only tape-drive cleaner to clean head and guides. Rough or abrasive materials can scratch metal parts; other solvents, such as carbon tetrachloride, may dissolve head lamination adhesive. Do not soak guides with cleaner, as excess solvent may break down bearing lubricant.

5.6. TAPE CLEANER. Clean the tape cleaner as follows:

- a. Remove head cover.
- b. Using a swab moistened with tape-drive cleaner, wipe away any accumulated debris clinging to tape scraper blades or housing.

CAUTION

Exercise great care to avoid damage to sharp edges of sapphire blades.

- c. Replace head cover.

5.7. HOUSING. The dust door and control panel may be cleaned, as necessary, with Miller-Stephenson Chemical Co. MS-260, Windex, or an equivalent commercial grade plastic cleaner.

MAINTENANCE OPERATION	FREQUENCY (hours)	QUANTITY TO MAINTAIN	PROCEDURE PARAGRAPH
Clean Head, Guides, Roller Guides, and Capstan	daily	—	5-4, 5-5
Clean Tape Scraper	daily	1	5-6
Check Skew, Tape Tracking and Speed	500	—	5-36 through 5-39, 5-43, and 5-29 through 5-31
Check Head Wear	2,500	1	5-41
Replace Reel Motors and Capstan Motor	10,000	3	Drawing No. 131000-0XX, Section VII

Table 5-1. Preventive Maintenance Schedule



Do not use rough or abrasive material to clean the plastic dust door, as permanent scratches may result.

5-8. REMOVAL, REPLACEMENT, AND MECHANICAL ADJUSTMENTS

5-9. Cipher transports are designed to operate for long periods of time without requiring adjustment. In the event that a mechanical adjustment is required, it is recommended that the unit be returned to the Cipher factory for that purpose. Procedures for removal and replacement of damaged or defective mechanical parts, together with any needed adjustments following replacement, are discussed in the following subparagraphs.

5-10. FUSE REPLACEMENT. The fuse is located on the back of the power bracket adjacent to the line cord. For a 105- to 125-Vac power source, a 6-ampere, 250-Vac, Type 3AG, norm-blo fuse is used; for a 210- to 250-Vac source, a 3- or 4-ampere, 250-Vac, Type 3AG, norm-blo fuse is provided.

5-11. PUSHBUTTON/INDICATOR LAMP REPLACEMENT. To replace a burned out indicator or pushbutton/indicator lamp, proceed as follows:

- a. Remove plastic indicator plate by grasping with fingers and pulling.
- b. If lamp socket is in center of copper clip which latches behind small shoulder on

each side of pushbutton/indicator body, proceed as follows:

- (1) Unlatch one or both ends of copper clip with screwdriver or other small instrument, and remove clip with defective lamp.
 - (2) Replace defective lamp in clip.
 - (3) Push clip into place in body.
- c. If lamp socket is in plastic switch/indicator body, with only small copper contact strip on one side of socket, proceed as follows:
- (1) Insert narrow screwdriver (3/16 inch, maximum) into small notch at side of socket *opposite* copper contact strip.
 - (2) Apply pressure to screwdriver, releasing lamp.
 - (3) Remove defective lamp and install replacement.
- d. Replace indicator plate.

5-12. SINGLE-EDGE TAPE GUIDE. To replace a damaged or worn single-edge tape guide (Figure 5-1) proceed as follows:

- a. Remove mounting screw from base plate and disassemble tape guide parts as required.

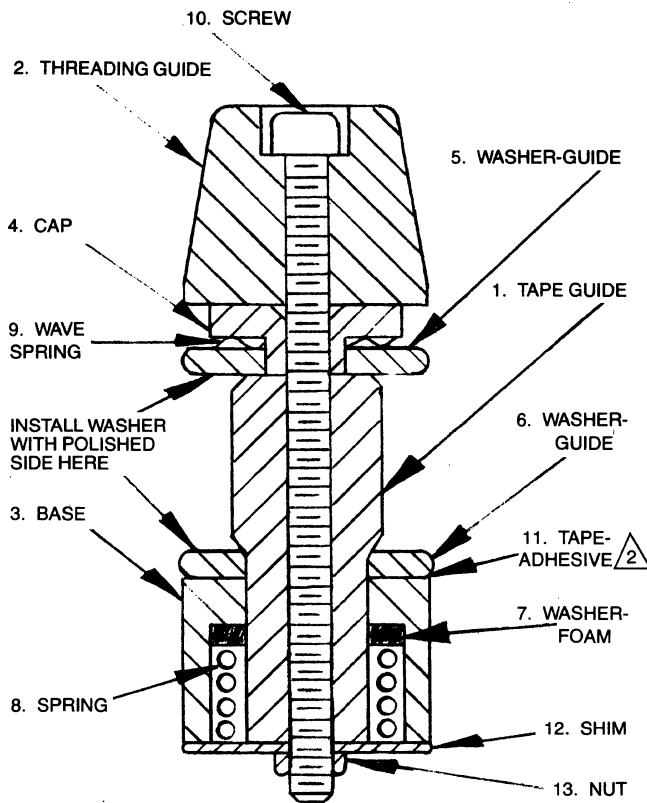

Note: Remove and discard items 12 and 13 before installing on unit.

Figure 5-1. Single-Edge Tape Guide

- b. Secure to base plate with mounting screw. No adjustment is required.

WARNING

Before performing any maintenance procedure requiring access to interior of transport, disconnect power cord to eliminate possibility of severe electric shock.

5-13. ROLLER TAPE GUIDE. Remove and replace a damaged or noisy roller tape guide as follows:

- a. Holding guide assembly with one hand, remove mounting screw from back of base plate. Remove guide assembly, being careful to save any shims removed from between roller tape guide and base plate as well as mounting screw for reassembly. (If guide is mounted on compliance arm, remove screw and washer from back of compliance arm, saving any shims and attaching parts.)

NOTE

Roller tape guide cannot be disassembled. If defective, it must be replaced as single unit.

- b. Coat mounting screw lightly with red Loctite and, using previously removed shims and attaching parts, install new roller tape guide.

CAUTION

When mounting guide on compliance arm, be careful not to crush arm by overtightening mounting screw.

5-14. TAPE SENSOR. The complete EOT/BOT sensor assembly is built and tested as a single unit and must be replaced as such. Removal and replacement procedures are as follows:

- a. Unplug electrical connector from control/servo PWB.
- b. Pull off cover over tape sensor.
- c. Remove three screws securing sensor brackets and cable clamp to front of base plate.
- d. Pulling wires and connector carefully through hole provided, remove sensor from base plate.
- e. Install replacement sensor in reverse order of removal, being careful to mount sensor at correct distance from tape. Sensor should be as far from tape as bracket will allow.
- f. Following installation, perform electrical adjustments in accordance with paragraph 5-22.

5-15. REEL-HUB GRIP RING. Removal and replacement procedures for the reel-hub grip ring are as follows:

- a. Lift reel lock lever to unclamp grip ring.
- b. Pull old grip ring out of hub groove and remove.
- c. Install new grip ring by stretching over reel hub into proper position.

CAUTION

Clean grip ring only with Freon degreaser, Type TF. Alcohol, head cleaner, and other solvents will damage grip ring.

5-16. REEL HUB. Replace and adjust the supply or takeup reel hub as follows (Figure 5-2):

- a. Loosen socket-head screws and remove hub.
- b. Install replacement hub on shaft to obtain dimension shown in Figure 5-2, and tighten socket-head screws.
- c. Mount reel of tape on transport, thread tape, and place transport in load mode.
- d. Run tape forward and reverse, noting tape position on reel for which replacement hub was installed. If necessary, readjust hub height to center tape on reel.
- e. Using right-angle Allen wrench capable of applying 30 inch-pounds of torque, tighten socket-head screws securing hub as tightly as possible.

5-17. HEAD ASSEMBLY. Replace the head assembly in accordance with the following procedures (Figure 5-3):

- a. Remove head and sensor covers.
- b. Unplug head electrical connectors from read/write PWB.
- c. Remove four screws securing head assembly to base plate, and remove outer azimuth screw.

NOTE

One of four mounting screws is small screw inside azimuth screw.

- d. Withdraw head assembly, carefully feeding wires and connectors through hole in base plate.
- e. Feed wires and connectors of replacement head assembly carefully through hole, and secure head assembly to base plate with three socket-head screws not used for azimuth adjustment. Thread outer azimuth adjustment screw into head assembly mount (Figure 5-3), and thread inner azimuth adjustment screw loosely into it.
- f. Make skew adjustment in accordance with paragraphs 5-36 through 5-39.
- g. Replace head and tape sensor covers.

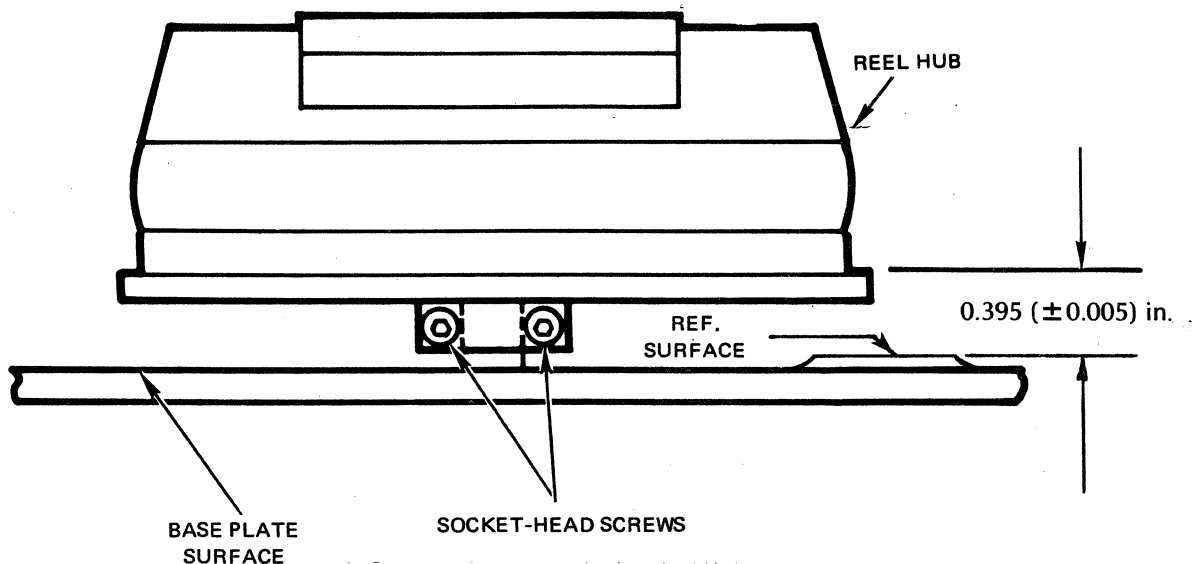

Figure 5-2. Reel Hub, Showing Adjustment Dimension

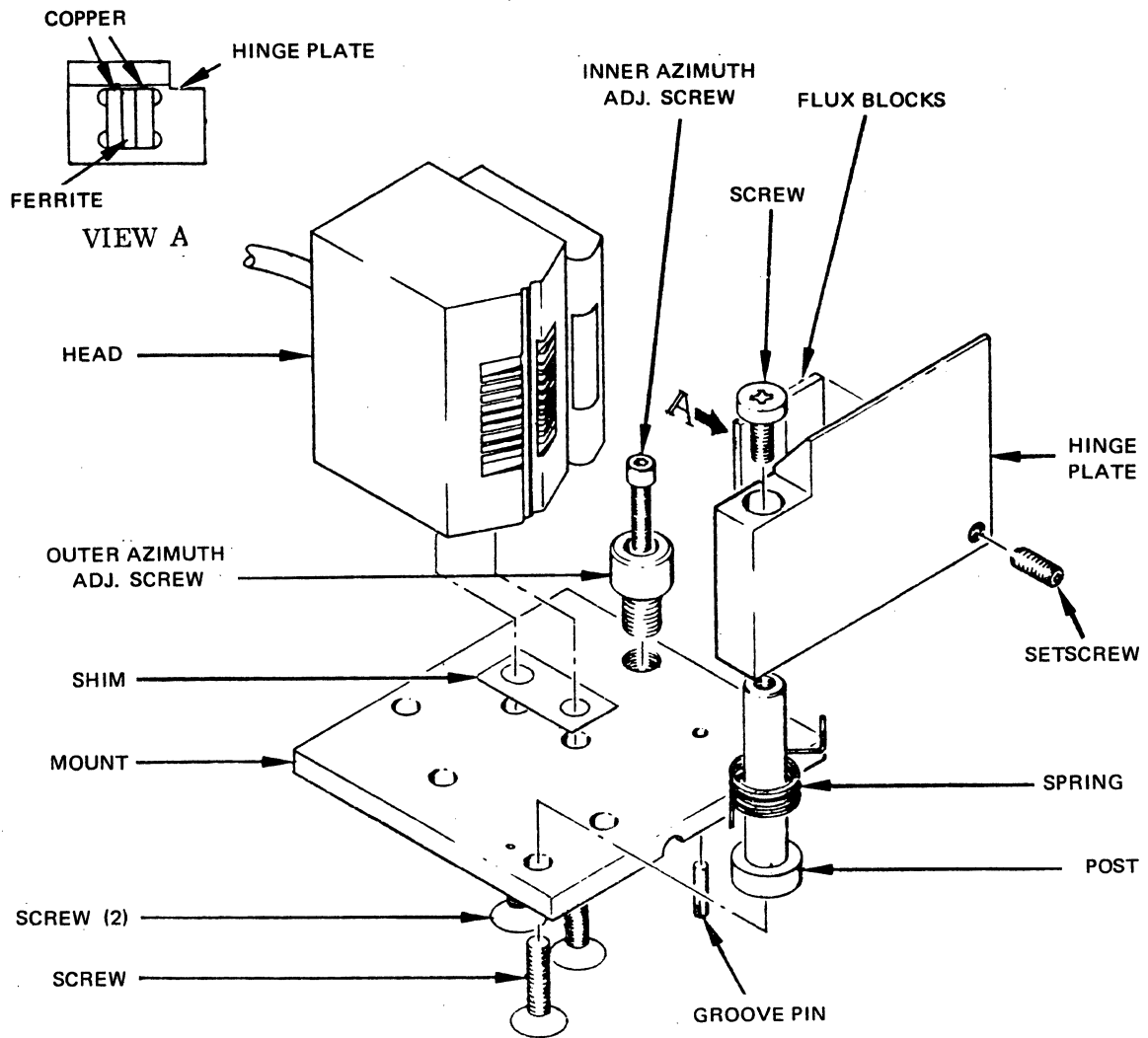

Figure 5-3. Head Assembly Adjustments

5-18. CAPSTAN. To replace a damaged or defective capstan, proceed as follows:

- a. Remove socket-head screw in end of capstan shaft, and take off capstan cap and sleeve.
- b. Install replacement capstan over capstan motor shaft, place capstan cap in place, and secure with screw.

erratic performance and render capstan sleeve useless.

- c. Mount reel of tape on transport, thread tape, and place in load mode. Check overall capstan performance and adjust if necessary in accordance with paragraph 5-43, steps l and m.

5-19. POWER SUPPLY CHECKS AND ADJUSTMENTS

5-20. UNREGULATED VOLTAGE CHECKS. Check unregulated voltages at plug P-14 on the power regulator portion of the control/servo printed circuit board. Required values and tolerances, as well as plug pin numbers, are presented in Table 5-2. In checking, ensure that the input line voltage is set to the correct value.



Avoid contact with sensitive tape-driving surface of capstan sleeve. Damage to this surface will cause

VOLTAGE PIN NO.	RETURN PIN NO.	REQUIRED READING (volts)
2	13 or 14	+ 40 (± 4)
4	13 or 14	- 40 (± 4)
10	13 or 14	+ 18 (± 2)
7	13 or 14	- 18 (± 2)
12	15	+ 10 (± 1)
3	5 or 6	+ 22 (± 2)
9	8	+ 22 (± 2)

Table 5-2. Power Supply Unregulated Voltages

5-21. **REGULATED POWER SUPPLY ADJUSTMENTS.** The potentiometers used for these adjustments are located on the power regulator portion of the control/servo board. Test point locations are shown in Figure 5-4. Referring to Table 5-3, for each of the three power supplies listed measure voltage across the test points shown and adjust the designated potentiometer until the required voltage is obtained.

NOTE

Check tape speed and adjust, if necessary, following power supply adjustments. (See paragraphs 5-27 through 5-31.)

SUPPLY	TEST POINT	RET. TEST POINT	ADJUSTMENT POT.	REQ. READING (volts)
+ 5-volt	TP105	TP102	R124	+ 5 (± 0.05)
+ 15-volt	TP101	TP102	R114	+ 15 (± 0.15)
- 15-volt	TP104	TP102	R119	- 15 (± 0.15)

Table 5-3. Power Supply Regulated Voltage Adjustments

5-22. TAPE SENSOR ADJUSTMENT

5-23. If either the end-of-tape (EOT) or beginning-of-tape (BOT) system is not functioning properly, or if a new tape sensor assembly has been installed, the complete tape sensor system must be readjusted in accordance with the procedure presented in paragraph 5-24. The potentiometers and test points used for these adjustments are located on the control/servo board. A chart of the test point and potentiometer locations on the control/servo board is presented in Figure 5-4.

5-24. Adjust the tape sensor system as follows:

- a. Turn on transport power, load tape, and position BOT reflector strip in front of sensor.

- b. Connect oscilloscope to test point TP18, and adjust potentiometer R64 until voltage at TP18 goes high. Measure and record voltage at TP21.
- c. Readjust R64 until voltage measured at TP21 is one-half reading of step b.
- d. Position EOT reflector strip in front of sensor.
- e. Connect oscilloscope to test point TP19, and adjust potentiometer R60 until voltage at TP19 goes high. Measure and record voltage at TP20.
- f. Readjust R60 until voltage measured at TP20 is one-half reading of step e.

5-25. COMPLIANCE ARM ADJUSTMENTS

5-26. Load and tension a tape on the transport. Adjust each compliance arm so that it is centered in its arc of travel. The center of the arc is indicated by a hole in the casting, 1/4 inch from the arm slot, which is clearly visible from the back of the transport. To center the supply arm, adjust potentiometer R202 on the control/servo board (clockwise or counterclockwise, as required to center the arm). To center the takeup arm, adjust potentiometer R402.

5-27. CAPSTAN SERVO ADJUSTMENTS

5-28. **DC OFFSET ADJUSTMENT.** With power applied (POWER indicator illuminated) and tape loaded but not running, measure the voltage at TP303 with respect to TP305 on the control/servo board. Adjust offset potentiometer R379 to obtain 0 (± 0.05) volts at TP303.

5-29. **COARSE SPEED ADJUSTMENT.** Make a coarse adjustment of speed in accordance with the following procedure:

- a. Monitor tachometer output voltage at TP301, located on capstan servo portion of control/servo board. (See Figure 5-4 for location of test points.)
- b. With transport in off-line mode (ON LINE indicator not illuminated), depress FORWARD pushbutton.
- c. Adjust forward potentiometer R312 until voltage at TP301 is as specified in Table 5-4.

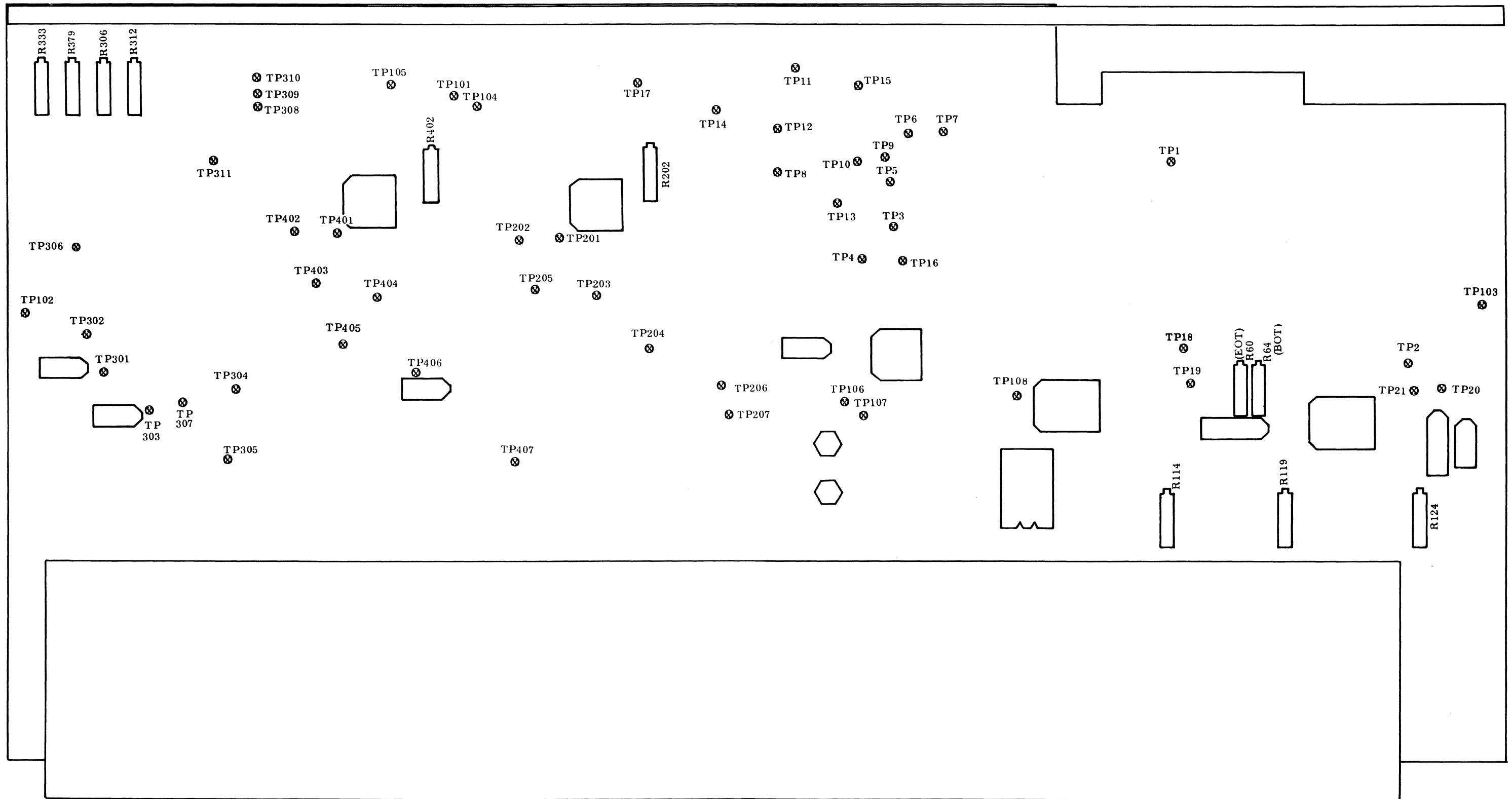

Figure 5-4. Control/Servo Board Test Point Chart

- d. Depress FORWARD pushbutton to stop tape motion, then depress REVERSE pushbutton.
- e. Adjust reverse potentiometer R306 until voltage at TP301 is as specified in Table 5-4.
- f. Depress REVERSE pushbutton to stop tape motion.
- d. Depress FORWARD pushbutton to stop tape motion.
- e. Depress REVERSE pushbutton.
- f. Adjust reverse speed control potentiometer R306 to obtain appropriate data rate listed in Table 5-4.

5-30. FINE SPEED ADJUSTMENT. Measure and make a fine adjustment of tape speed as follows:

- a. Load known-density master skew tape on transport. Connect counter to TP10 on data board. (See Figure 5-5 for test point locations.)
- b. With transport in off-line mode (ON LINE indicator not illuminated) depress FORWARD pushbutton and adjust counter to trigger on negative-going edge of data pulse.
- c. Adjust forward speed control potentiometer R312 on capstan servo portion of control/servo board to obtain appropriate data rate, as listed in Table 5-4. (For densities other than 800 bpi, compute frequency by multiplying density and tape speed and adding 1 percent tolerance: $f = \text{bpi} \times \text{ips} \pm 1\%$.)

- g. Depress REVERSE pushbutton to stop tape motion.
- h. Readjust ramp time in accordance with paragraph 5-32.

5-31. SUBSTITUTE ADJUSTMENT PROCEDURE.

If desired, a speed adjustment with an accuracy of 2% can be obtained with the use of the strobe disc (Figure 5-6) mounted on the capstan. (If not included on the transport, order Cipher Part No. 731015-700 for a 12.5, 25, or 37.5-ips transport; Part No. 731024-800 for a 45-ips transport; or Part No. 731024-820 for a 75-ips transport.) With the transport in off-line mode, depress the FORWARD pushbutton. Adjust forward potentiometer R312 until the strobe disc appears to be motionless (outside lines for 60 Hz, inside lines for 50 Hz). To adjust reverse speed, use the same procedure, but depress the REVERSE pushbutton and adjust using reverse potentiometer R306.

TAPE SPEED (ips)	TP301 VOLTS (appr.)	RAMP TIME (ms)	DATA RATE (ch/s at 800 bpi) (nominal)	R-A-W DELAY (ms)
12.5	0.44	30	10,000	12.0
18.75	0.66	20	15,000	8.00
25	0.88	15	20,000	6.00
37.5	1.32	10	30,000	4.00
45	1.58	8.33	36,000	3.33
REWIND 150	5.26	500 (appr.)		

NOTE: Ramp times given in this table are for specified start/stop distance (0.19 inch) and are measured from 0 to 100% of ramp. If different start/stop distances are required or

if 10% and 90% points are to be measured, times may be scaled linearly. To maintain specified tolerance, these time settings should be within $\pm 10\%$.

Table 5-4. Capstan Servo Adjustment Parameters

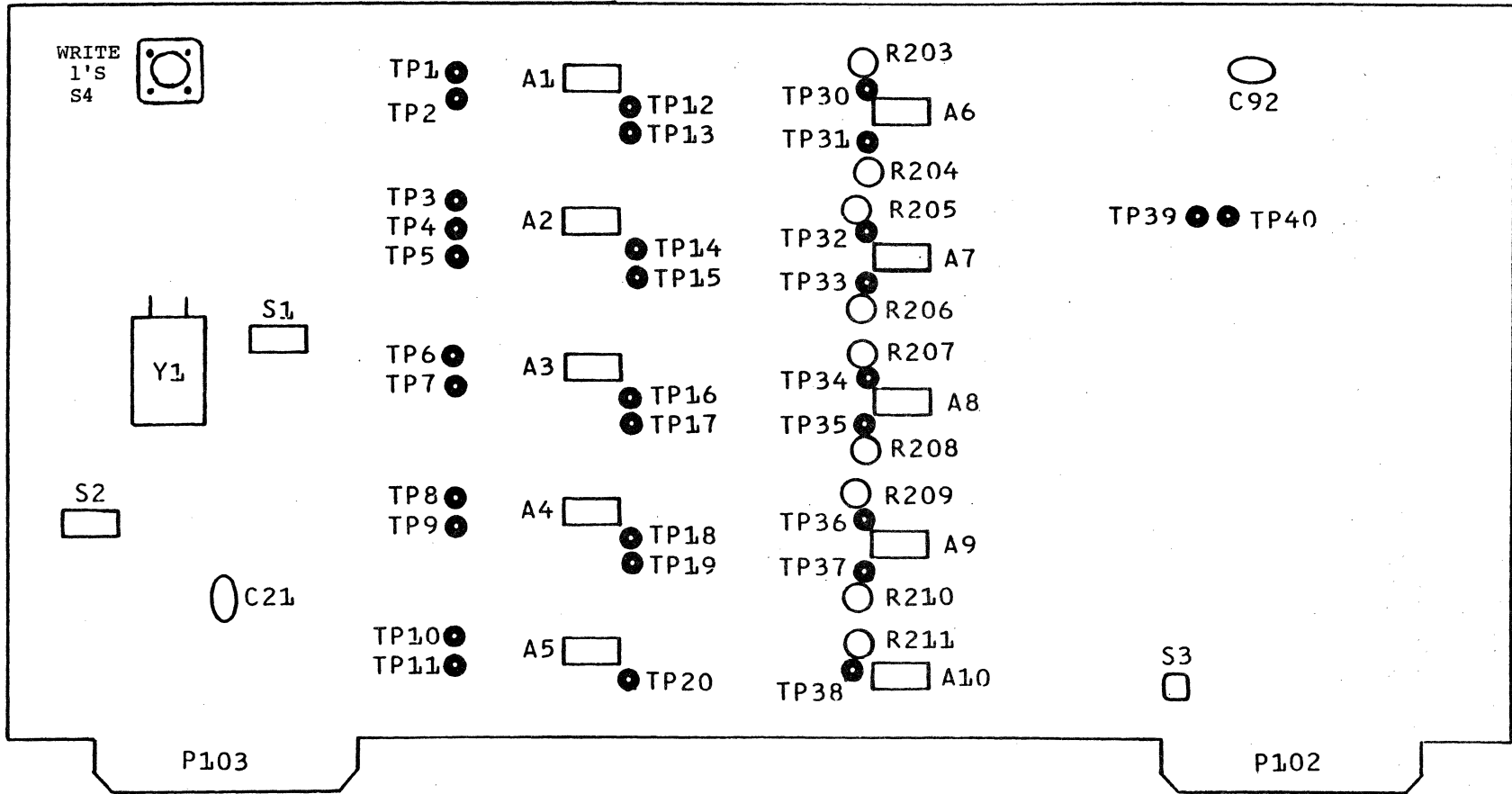

Figure 5-5. Test Points and Adjustment Potentiometers, Dual-Mode PWB

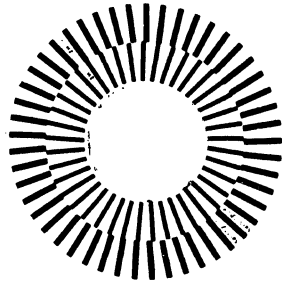

Figure 5-6. Strobe Disc

5-32. RAMP ADJUSTMENT. This adjustment is to be made while starting and stopping the tape motion and observing the ramp in both forward and reverse modes. This can be done with the transport on line while writing blocks of data or off line by using the FORWARD and REVERSE pushbuttons.

- a. Use oscilloscope to monitor TP301 (Figure 5-4), on control/servo board, with respect to TP102.
- b. Alternately start and stop transport at a rate which is convenient for observing ramp.
- c. Trigger oscilloscope with run command at TP309.
- d. Adjust potentiometer R333 to obtain applicable ramp time specified in Table 5-4. (See Figure 5-7.)

5-33. DATA PWB INITIAL SWITCH SETTINGS

5-34. Refer to Tables 5-5 and 5-6 for all switch settings and functions.

5-35. Before making adjustments on the data PWB, set the switches initially to the following positions:

- a. Switch 1, positions 1 and 2: both closed.
- b. Switch 1, positions 3 and 4: see Table 5-5 for position versus transport tape speed.

- c. Switch 1 positions 5 through 7: all open.
- d. Switch 1, position 8: closed.
- e. Switch 2, position 4: closed
- f. Switch 2, position 5: open.
- g. Switch 2, positions 6 and 7: see Table 5-6.
- h. Switch 3, position 1: open.
- i. Switch 3, positions 2 through 4: see Table 5-6.



With pushbutton switch 4 closed all tapes will be write enabled. Ensure that this switch is open for normal operation to prevent the erasure of recorded tapes.

5-36. READ GAIN ADJUSTMENTS

5-37. NRZI. Adjust NRZI read gain as follows:

- a. Change switch settings as follows:
 - (1) Switch 1, position 6: closed.
 - (2) Pushbutton switch 4: closed.
 - (3) Switch 2, position 1: closed.
 - (4) Switch 2, position 2: closed.

TAPE SPEED (ips)	CRYSTAL FREQUENCY (MHz)	SWITCH 1	
		Position 3	Position 4
12.5	1.280	Open	Closed
18.75	1.920	Open	Closed
25.0	1.280	Closed	Open
37.5	3.840	Open	Closed
45.0	4.608	Open	Closed
75.0	3.840	Closed	Open
90	4.608	Closed	Open
125	6.400	Closed	Open

Table 5-5. Tape Speed Crystal Frequencies and Switch 1 Settings.

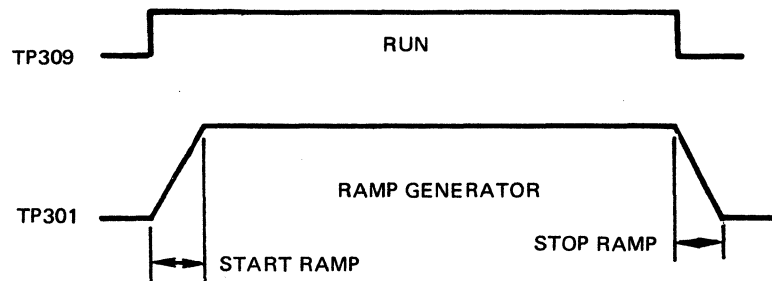

Figure 5-7. Ramp Adjustment Traces

SWITCH	POSITION		FUNCTION
1	1	2	
	Open	Open	Skew Gate = 12%
	Open	Closed	Skew Gate = 25%
	Closed	Open	Skew Gate = 37%
	Closed	Closed	Skew Gate = 50%
	3	4	
	Closed	Open	Running Freq. = Crystal Frequency
	Open	Closed	Running Freq. = 1/2 Crystal Frequency
	5 Closed		Provides PE (3200 fci) write clock in test mode
	6 Closed		Provides NRZI (800 fci) write clock in test mode
7 Closed		To view skew at TP10 in skew test	
8 Closed		Selects high-speed status	
2	1 Closed		Enables transport select in test mode
	2 Closed		Enables 800 fci in test mode
	3 Closed		Enables 1600 fci in test mode
	4	5	
	Open	Open	Low threshold detect
	Closed	Open	Normal threshold detect
	Closed	Closed	High threshold detect
	6	7	
	Open	Open	Low Density
	Open	Closed	Control servo density select
Closed	Closed	High Density	
3	1 Closed		Enables write reset (WRT, P20-2) on control/servo or control power PWB
	2 Closed		Enables higher write current (with head P/N 799010-601 only)
	3 and 4 Open		Enables 12V regulators.
	3 and 4 Closed		Not used.
4	Closed		Write PE or NRZI in test mode; all tapes write enabled, file protect inoperative.

Table 5-6. Switch Settings for Testing and Options

NOTE

Switch settings, on the data board for test mode, override the front panel HI DEN indicator.

- b. Start writing all-1's record by depressing FWD pushbutton (indicator illuminated).
- c. Referring to Figure 5-5, connect oscilloscope to TP30 and ground.
- d. Adjust gain potentiometer R203 to obtain 8-volt reading (peak-to-peak) on oscilloscope. This adjusts gain for Channel P.
- e. Repeat for Channels 0 through 7, using TP31 through TP38 and R204 through R211, respectively.

5-38. NRZI WRITE SKEW VERIFICATION. Check NRZI write skew as follows:

- a. Close position 7 of switch 1.
- b. Connect oscilloscope to TP10.
- c. Proper waveform is shown in Figure 5-8.

5-39. PHASE-ENCODE READ GAIN VERIFICATION. Check PE skew as follows:

- a. Make the following changes in switch positions:
 - (1) Switch 1, position 5: closed.
 - (2) Switch 1, position 6: open.
 - (3) Switch 1, position 7: open.
 - (4) Switch 2, position 2: open.
 - (5) Switch 2, position 3: closed.

- b. Start writing all-1's tape by actuating FWD pushbutton/indicator (indicator illuminated).
- c. Verify 4-volt reading (peak-to-peak) at TP30 through TP38.

5-40. HEAD AZIMUTH ADJUSTMENT. Adjust read skew as follows:

- a. Return all switches to initial settings (paragraph 5-35).
- b. Close switch 1, position 7, and switch 2, positions 1 and 2.
- c. Load and tension 800-bpi master skew tape.
- d. Connect oscilloscope to TP10 on data board (Figure 5-5) and ground.
- e. With transport in off-line, low-density mode (ON LINE and HI DEN indicators extinguished), depress FORWARD pushbutton.
- f. Adjust azimuth screws (Figure 5-3) on head mounting plate so that outputs of all tracks, as monitored at TP10, fall within 10% or less of byte-to-byte period. (See Figure 5-8.) Outer azimuth screw bears against transport mounting plate and pivots head assembly outward. Inner azimuth screw threads into transport mounting plate and pulls head assembly inward. Inner screw also serves to lock adjustment.

5-41. Return PWB to normal operating mode by setting all switch positions in accordance with Paragraph 5-35.

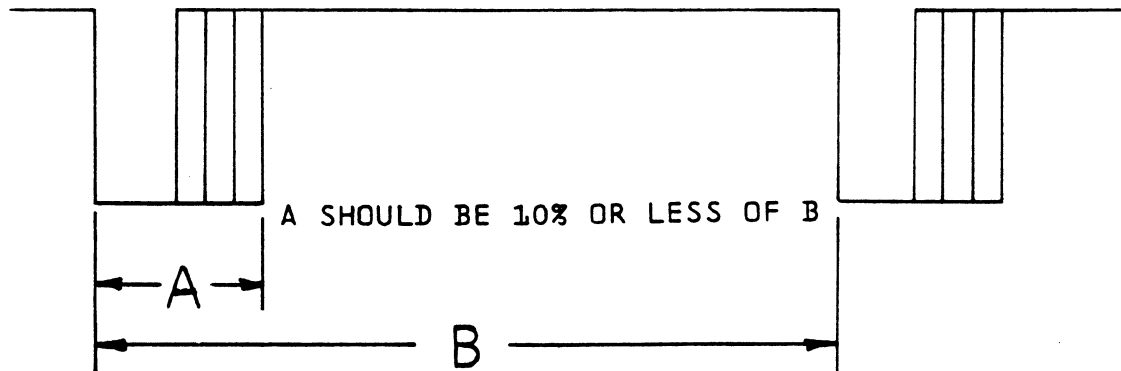

Figure 5-8. Skew Pulse at TP10

5-42. MECHANICAL ADJUSTMENTS

5-43 TAPE PATH ALIGNMENT. Referring to Figure 5-9, align the tape path in accordance with the following procedure:

- a. Remove two head covers and facade.
- b. Remove single-edge spring guide nearest capstan.
- c. Remove roller tape guides No. 1 and 2. Save any shims removed.
- d. Remove roller tape guides from upper and lower compliance arms. Save any shims removed.
- e. Position lower compliance arm directly under hole where roller guide No. 1 is normally mounted. Using vernier caliper, measure depth from No. 1 roller guide mounting surface to near side surface of compliance arm. Subtract this dimension from 0.545 inch to determine thickness of shim to be used between lower compliance arm roller guide and compliance arm.
- f. Select shim of proper thickness and mount roller guide to compliance arm with this shim.

NOTE

Mounting screw should be coated lightly with red Loctite before assembly. Take care not to crush compliance arm by overtightening mounting screw.

- g. Position upper compliance arm directly under mounting hole for roller guide No. 2. Repeat steps e and f for upper compliance arm roller guide.
- h. Install roller guides No. 1 and 2, using 0.010-inch shim between guide base and top plate. Secure roller guides lightly, but do not use Loctite on mounting screws at this time.
- i. Mount reel of tape on transport, thread tape, and load.
- j. Before running tape, adjust angle of tape cleaner so that it is tangent to tape path. Make sure tape contacts only curved face and does not touch either

edge of cleaner. Check that BOT/EOT reflector does not touch tape.

- k. Run tape forward and reverse, and adjust reel hub height to center tape on reels, if necessary.
- l. Hold tape guide, Cipher Part No. 710008-500, in position 1, so that tape wraps slightly around small diameter of guide. Run tape forward and observe position of tape on capstan sleeve. Stop tape and remove tape guide.
- m. Again, run tape forward and determine if tape position on capstan sleeve moves toward or away from top plate. If tape moves away from top plate when tape guide is removed, capstan sleeve must be tilted upward. If tape moves toward top plate when tape guide is removed, capstan sleeve must be tilted downward. (To tilt capstan sleeve, tilt capstan motor by inserting shims between capstan motor standoff and back surface of top plate.) Shim capstan motor until tape position on capstan sleeve does not shift when tape guide is removed from position 1. Reinstall single-edge spring guide removed in step b.
- n. Run tape forward and note position of tape on capstan sleeve. Run tape in reverse and again note position of tape on capstan sleeve. If tape moves away from top plate in reverse direction, reduce thickness of shim under roller guide No. 2. If tape moves toward top plate in reverse direction, add shims under roller guide No. 2. When roller guide No. 2 is properly adjusted, tape position on capstan sleeve will be same in forward and reverse directions.
- o. Mount prerecorded master skew tape on tape transport. Adjust head azimuth as outlined in paragraph 5-40. Total skew, as measured at test point, must be less than 10% of a byte space in forward direction and 15% of a byte space in reverse direction.
- p. With master skew tape running forward alternately depress spring-loaded washers on single-edge guides. Skew should increase a minimum of 5% up to a maximum of 20% over the normal forward skew pulse. If no increase is noted when incoming guide washer is depressed, remove some shims from roller guide No. 1, nearest supply compliance arm. If ex-

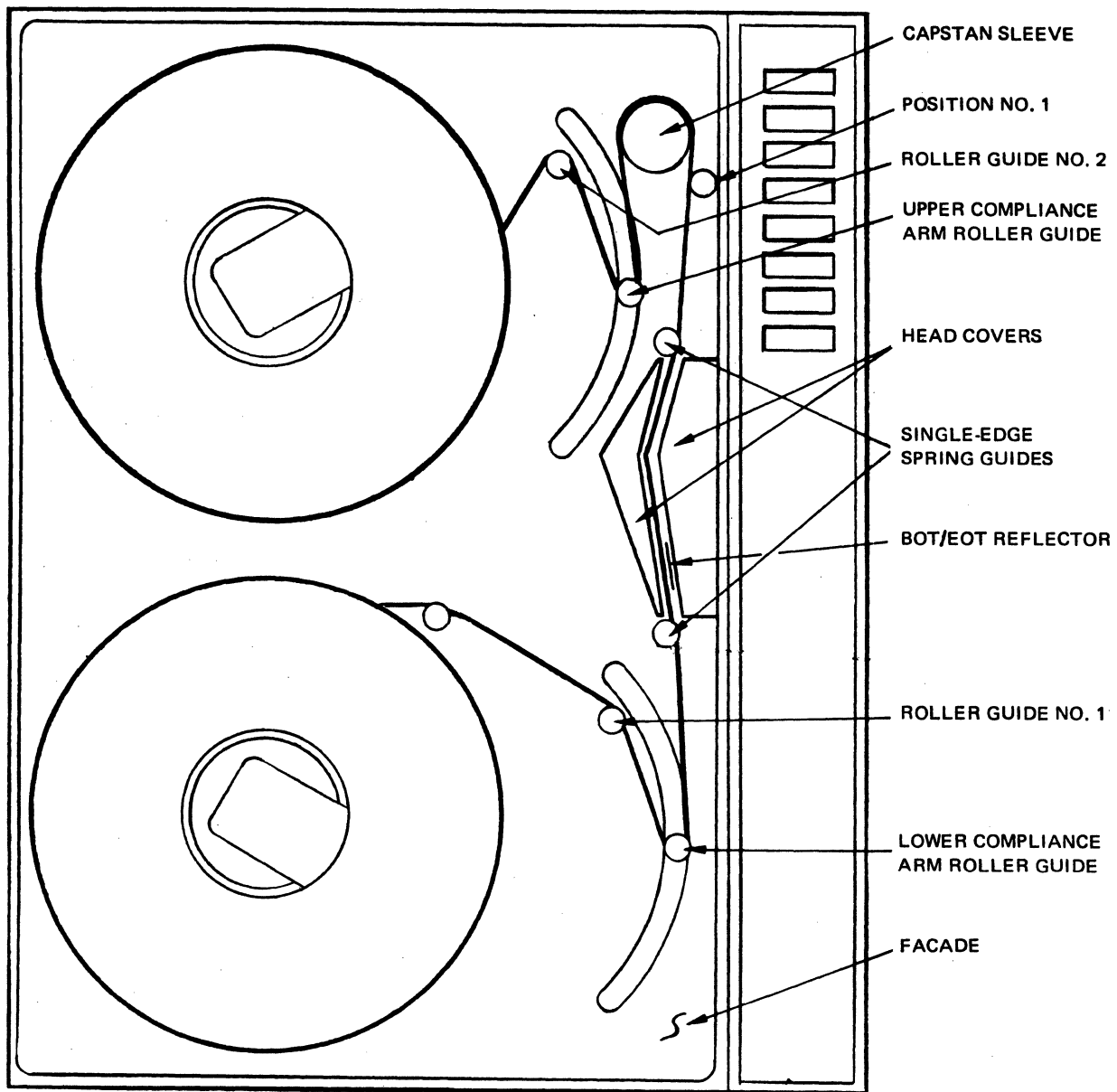

Figure 5-9. Tape Path and Related Parts

- cess skew is observed, add some shims to roller guide No. 1. If no skew increase is noted when outgoing guide washer is depressed, capstan motor must be tilted slightly away from guide. If excess skew is observed when outgoing guide washer is depressed, tilt capstan motor slightly toward guide.
- q. Run master tape in reverse, and depress washer of single-edge guide nearest capstan. Observe skew. It should increase a minimum of 5% up to a maximum of 20% over the normal reverse skew pulse. If no increase in skew is noted remove some shims from roller guide No. 2. If excess skew is observed, add some shims under roller guide No. 2.
 - r. Secure all mounting screws with red Loctite. Take care not to misplace any of adjustment shims when reassembling.
 - s. Run tape in forward and reverse directions. Check all rollers and guides for excessive tape walk, shifting, or edge curl. Verify that head azimuth is still correct in both forward and reverse directions. When measured with a master skew tape, skew must not exceed 10% of a byte space in forward direction, and 15% of a byte space in reverse direction.
 - t. Replace facade and head covers.
- b. If lock has free play in open position, loosen locknut on adjustment setscrew. Turn adjustment setscrew into spacer until free play is removed, and tighten down locknut.
 - c. Close lock and note whether face of lock is parallel to top of cap. If not, open lock and turn buttonhead screw in or out as necessary to hold lock parallel to top of cap in closed position.
 - d. Place reel on hub, close lock, and check reel for tightness. If reel slips on hub, open lock and remove reel.
 - e. Loosen hex locknut on adjustment setscrew, turn adjustment setscrew slightly into spacer (depending upon looseness of reel), and retighten locknut.
 - f. Perform steps c and d.
 - g. Perform steps e, c, and d as necessary until reel does not slip.

NOTE

Hub compression ring contains oily preservative which tends to ooze out through pores and make surface oily. Ring should be cleaned periodically with Freon TF degreaser, No. 2002, to prevent tape reel from slipping.

5-44. REEL HUB ADJUSTMENT. Referring to Figure 5-10, adjust the reel hub as follows:

- a. Remove tape reel and leave lock open.

5-45. COMPLIANCE ARM LIMIT SWITCH ADJUSTMENT. Two nylon screws, one threaded through each compliance arm, are used to adjust

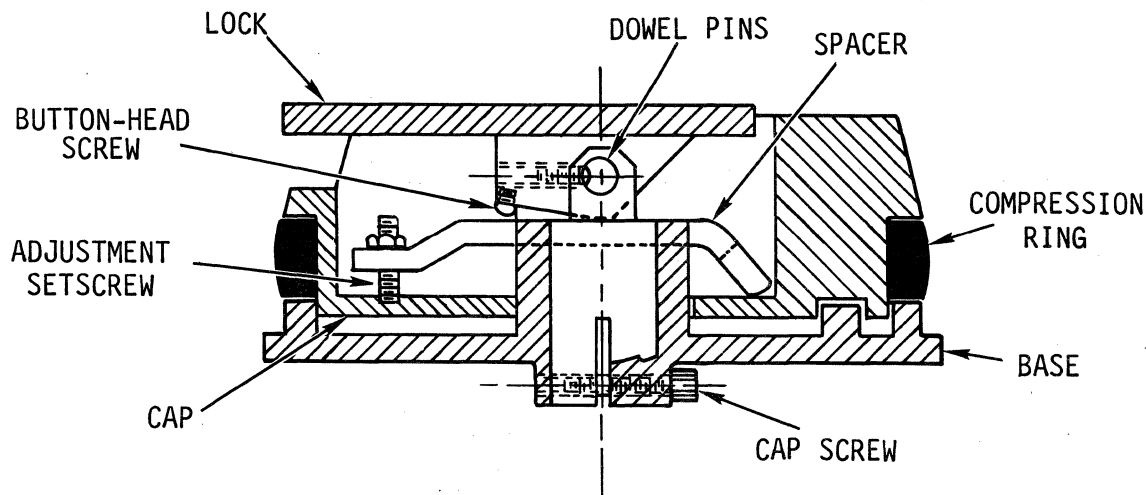

Figure 5-10. Reel Hub Assembly

the upper and lower switch points of the microswitches in the arm assemblies. Both compliance arms are adjusted in the same manner.

- a. Adjust right-hand screw in or out, as necessary, to cause microswitch to actuate when compliance arm is approximately 5 degrees from its full-down position.
- b. Adjust left-hand screw to actuate microswitch with compliance arm approximately 20 degrees from its full-up position.

5-46. COMPLIANCE ARM RETRACTOR MOTOR SWITCH ADJUSTMENT. Adjust each of the two cam-actuated retractor motor switches by bending the actuating lever carefully until the switch is actuated by the cam pin. Adjust the up-position switch to close when the retractor arm is in its full-up position, the down-position switch to close when the arm is in its full-down position.

5-47. REPLACEMENT OF ASSEMBLIES

5-48. These instructions are designed to guide the service engineer in a logical, step-by-step procedure for replacing assemblies.

5-49. CONTROL/SERVO BOARD. Replace the control/servo board in accordance with the following procedure:

- a. Disconnect all cables from board.
- b. Remove screws from corners of mounting bracket as shown in Figure 5-11.
- c. Slide board out of top and bottom mounting brackets.
- d. Slide in replacement board, and screw bracket back together at corners.
- e. Connect power supply cable to connector P14, and connect control panel connectors to P2 and P3.
- f. Turn on power and check power supply voltages according to instructions in paragraphs 5-19 through 5-21.
- g. Connect BOT/EOT cable to connector P5, and adjust BOT/EOT sensors according to instructions in paragraphs 5-22 through 5-24.

- h. Connect supply reel motor cable to connector P10, supply compliance arm cable to connector P11, and retractor motor switch cable to connector P6.
- i. Thread 6-inch piece of tape over head and past BOT/EOT assembly as if loading tape drive. Do not mount tape reel on hub at this time.
- j. Depress LOAD pushbutton and hold supply compliance arm at center of arc of travel with hand or piece of scotch tape, or prop it in place with piece of cardboard.
- k. Adjust potentiometer R202 (Figure 5-4) until supply reel motor stops turning, with supply arm held still at center of its arc.
- l. Release supply arm and disconnect supply arm cable from connector P11.
- m. Connect takeup arm and reel motor cables to connectors P12 and P13.
- n. Repeat steps i through k for takeup servo.
- o. Release takeup arm and reconnect supply arm cable to connector P11.
- p. Connect all remaining cables: capstan motor (red and black leads) to connector P9, capstan motor dc tachometer to connector P8, and file protect switch to connector P4.
- q. Mount reel of tape on transport. Thread tape and depress LOAD pushbutton one time. Compliance arms should position near centers of arcs, and capstan motor should be enabled but not running.
- r. Adjust supply and takeup arms for proper center positions according to instructions in paragraphs 5-25 and 5-26.
- s. Adjust capstan servo in accordance with instructions in paragraphs 5-27 through 5-31.

5-50. REMOVAL AND REPLACEMENT OF PARTS AND COMPONENTS

5-51. Replacement parts and components should be selected from the parts list in Section VII. Use standard tools and procedures in removing and

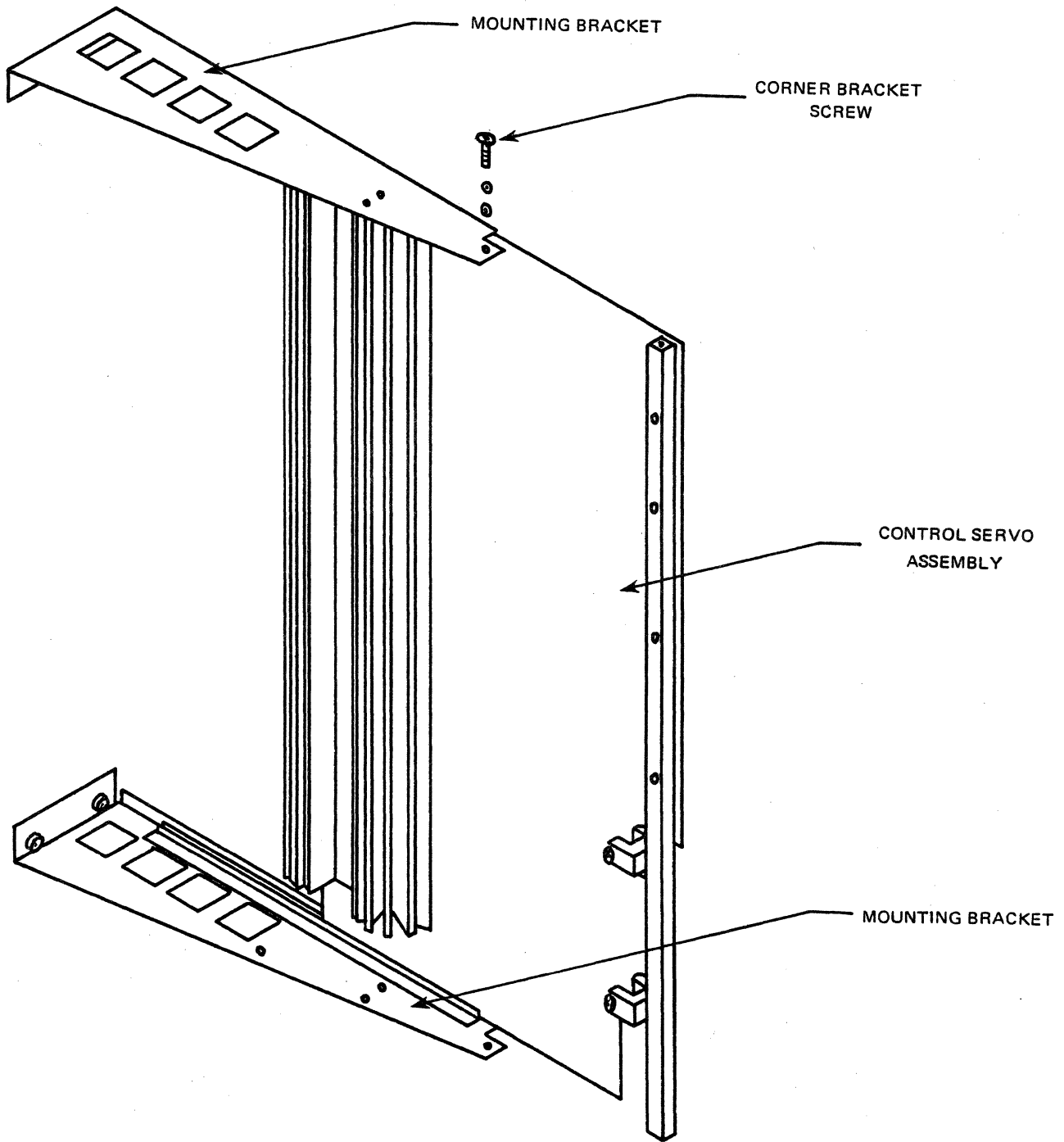

Figure 5-11. Control/Servo Board Removal

installing parts, with the assistance of the drawings in Section VII. Observe the following special procedures in removing parts from and installing them on printed wiring boards:



To prevent excessive heat from damaging printed wiring boards and components, especially semiconductors, use a soldering iron rated at not more than 40 watts or 600°F, and do not heat solder for more than 10 seconds. When soldering, always use heat sink (alligator clip, long-nose pliers, etc.).

- a. Use only 60-40 tin-lead solder with non-corrosive, nonconducting flux. Use alcohol or commercial flux-removing solvent to remove flux residue.
- b. After component has been removed from board, clean all solder from connections (plated-through holes) with commercial solder sucker (Soldapullt desoldering tool, Edsyn Co., or equivalent).
- c. Use only exact replacement parts. (Refer to Section VII.).
- d. Do not alter wiring or layout.

5-52. **MULTIPLE-LEAD COMPONENTS.** Follow instructions presented in paragraph 5-51 for removal of a defective two- or three-lead component. Bend the leads on the replacement component to the proper shape and install. Heat may be applied to either side of the printed wiring board, as necessary.

5-53. **MULTIPLE-PIN COMPONENTS.** The following special instructions apply to the removal and replacement of multiple-pin components, including integrated circuits.



Exercise great care in the removal of multiple-pin components from printed wiring boards to avoid damage to boards.

- a. Remove defective component by carefully cutting each lead close to component, using jeweler-type diagonal cutter.
- b. Remove lead ends and solder from holes in board in accordance with instructions in paragraph 5-51.
- c. Straighten leads in replacement component for insertion in board and install.

5-52. PROGRAMMING WRITE DESKEW PROM

5-53. Inscribed on the tape head of the transport is an eight-digit code number which describes the deskew pattern to be programmed into the write deskew PROM (U90, Drawing No. 154040-009) to implement a write deskew pattern on the dual-mode data PWB for that head. The position of each digit in the code corresponds to a head channel number, starting with channel 7 on the left, to channel 0 on the right. The one exception is that position 2 of the code corresponds to channel P (parity). Channel 2 is the reference channel. The numerical value of each digit of the code corresponds to the address of its channel for which a 0 must be programmed into the PROM.

5-54. Tables 5-7, 5-8, and 5-9 are illustrative examples of bit maps of programmed PROMs required for three different hypothetical head codings. Column heading numbers correspond to head channel numbers (except for 2). Each 1 in the tables represents a logic high, and each 0 represents a logic low. Note that there is one and only one 0 in each bit column and that there are no 0's from address 10 to address 1F. There may be none, one, or more than one 0's in each of addresses (rows) 00 through 0F.

5-55. **PROCEDURE.** To program a PROM with a specific code, proceed as follows:

- a. Obtain unprogrammed PROM, Cipher Part No. 203565-123 (82S123 or equivalent).
- b. Note code on tape head with which PROM is to be used.
- c. Program PROM in accordance with manufacturer's specifications to obtain logic lows at address/bit locations indicated by code and logic highs at all other locations.

NOTE

Most PROM distributors are equipped to program PROMs.

ADDRESS	BIT LOCATION							
	7	6	5	4	3	2	1	0
00	1	1	1	1	1	1	1	1
01	1	1	1	1	1	1	1	1
02	0	1	1	1	1	1	1	1
03	1	0	1	1	1	1	1	1
04	1	1	0	1	1	1	1	1
05	1	1	1	0	1	1	1	1
06	1	1	1	1	0	1	1	1
07	1	1	1	1	1	0	1	1
08	1	1	1	1	1	1	0	1
09	1	1	1	1	1	1	1	0
0A	1	1	1	1	1	1	1	1
0B	1	1	1	1	1	1	1	1
0C	1	1	1	1	1	1	1	1
0D	1	1	1	1	1	1	1	1
0E	1	1	1	1	1	1	1	1
0F	1	1	1	1	1	1	1	1
10	1	1	1	1	1	1	1	1
11	1	1	1	1	1	1	1	1
12	1	1	1	1	1	1	1	1
13	1	1	1	1	1	1	1	1
14	1	1	1	1	1	1	1	1
15	1	1	1	1	1	1	1	1
16	1	1	1	1	1	1	1	1
17	1	1	1	1	1	1	1	1
18	1	1	1	1	1	1	1	1
19	1	1	1	1	1	1	1	1
1A	1	1	1	1	1	1	1	1
1B	1	1	1	1	1	1	1	1
1C	1	1	1	1	1	1	1	1
1D	1	1	1	1	1	1	1	1
1E	1	1	1	1	1	1	1	1
1F	1	1	1	1	1	1	1	1

Table 5-7. Bit Map, Code
23456789

ADDRESS	BIT LOCATION							
	7	6	5	4	3	2	1	0
00	1	1	1	1	1	1	1	1
01	1	1	1	1	1	1	1	1
02	1	1	1	1	1	1	1	1
03	1	1	1	1	1	1	1	1
04	1	1	1	1	1	1	1	1
05	1	1	1	1	1	1	1	1
06	1	1	1	1	1	1	1	1
07	0	0	0	0	0	0	0	0
08	1	1	1	1	1	1	1	1
09	1	1	1	1	1	1	1	1
0A	1	1	1	1	1	1	1	1
0B	1	1	1	1	1	1	1	1
0C	1	1	1	1	1	1	1	1
0D	1	1	1	1	1	1	1	1
0E	1	1	1	1	1	1	1	1
0F	1	1	1	1	1	1	1	1
10	1	1	1	1	1	1	1	1
11	1	1	1	1	1	1	1	1
12	1	1	1	1	1	1	1	1
13	1	1	1	1	1	1	1	1
14	1	1	1	1	1	1	1	1
15	1	1	1	1	1	1	1	1
16	1	1	1	1	1	1	1	1
17	1	1	1	1	1	1	1	1
18	1	1	1	1	1	1	1	1
19	1	1	1	1	1	1	1	1
1A	1	1	1	1	1	1	1	1
1B	1	1	1	1	1	1	1	1
1C	1	1	1	1	1	1	1	1
1D	1	1	1	1	1	1	1	1
1E	1	1	1	1	1	1	1	1
1F	1	1	1	1	1	1	1	1

Table 5-8. Bit Map, Code
77777777

ADDRESS	BIT LOCATION							
	7	6	5	4	3	2	1	0
00	1	1	1	1	1	1	1	1
01	1	1	1	1	1	1	1	1
02	1	1	1	1	1	1	1	1
03	1	1	1	1	1	1	1	1
04	1	1	1	1	1	1	1	1
05	1	1	1	1	1	1	1	1
06	0	1	1	1	1	1	1	1
07	1	0	1	1	1	1	1	0
08	1	1	0	1	1	1	0	1
09	1	1	1	0	1	0	1	1
0A	1	1	1	1	0	1	1	1
0B	1	1	1	1	1	1	1	1
0C	1	1	1	1	1	1	1	1
0D	1	1	1	1	1	1	1	1
0E	1	1	1	1	1	1	1	1
0F	1	1	1	1	1	1	1	1
10	1	1	1	1	1	1	1	1
11	1	1	1	1	1	1	1	1
12	1	1	1	1	1	1	1	1
13	1	1	1	1	1	1	1	1
14	1	1	1	1	1	1	1	1
15	1	1	1	1	1	1	1	1
16	1	1	1	1	1	1	1	1
17	1	1	1	1	1	1	1	1
18	1	1	1	1	1	1	1	1
19	1	1	1	1	1	1	1	1
1A	1	1	1	1	1	1	1	1
1B	1	1	1	1	1	1	1	1
1C	1	1	1	1	1	1	1	1
1D	1	1	1	1	1	1	1	1
1E	1	1	1	1	1	1	1	1
1F	1	1	1	1	1	1	1	1

Table 5-9. Bit Map, Code
6789A987

SECTION VI TROUBLESHOOTING

6-1. GENERAL

6-2. This section presents probable causes and remedies for the more common types of tape transport malfunctions. For malfunctions not covered by these instructions, proceed in accordance with standard troubleshooting practices, referring to the schematic diagrams and drawings presented in Section VII.

6-3. TROUBLESHOOTING

6-4. Before performing any troubleshooting operation, the technician must have a good understanding of the theory of operation of the transport and any associated equipment. He should check carefully to ensure that all equipment is connected properly and that all associated equipment is in good operating condition. He should be thoroughly familiar with operating instructions and follow them carefully in performing the troubleshooting procedure.

6-5. PROCEDURE. While it is recognized that each individual malfunction will require its own specific troubleshooting procedure, the following steps will serve as guidelines in the performance of any such operation:

- a. As first step, inspect entire unit visually for any signs of damaged or overheated

components. Also, listen for unusual noises, while transport is operating, which may indicate mechanical malfunction.

- b. When a defective component is located, identify it by referring to Section VII for part number and/or value.
- c. If replacement part is available, substitute it for suspected defective part.

NOTE

If correction of any malfunction involves major realignment of transport, it is recommended that unit be returned to Cipher Data Products for factory repair and adjustment.

6-6. COMMON PROBLEMS. Table 6-1 lists common problems associated with operation of a tape transport, together with the probable cause and remedy for each.

6-7. SYSTEM TROUBLESHOOTING. Table 6-2, used in conjunction with the schematic diagrams in Section VII, provides an aid in the isolation of electrical/electronic system faults and their remedies.

TROUBLE	PROBABLE CAUSE	REMEDY
Reel flanges scrape tape	Reels improperly mounted	Reinstall reel evenly (see Section III)
BOT and EOT markers not sensed	Dirt covering reflective strip or sensor	Clean sensor or reflective strip
Reels continue to rotate after tape leaves photosensor	Upper compliance arm limit switch out of adjustment or faulty	Readjust or replace limit switch
Tape fails to pull properly through machine or spills	Improper tape threading	Rethread tape (see Section III)
Excessive data dropout	Dirt on head or damaged tape	Clean head (Section V) and/or install new certified computer tape
Transport will not function at all	Defective fuse	Replace fuse
POWER switch-light does not illuminate	No primary power	Check for primary power
	Defective indicator lamp	Replace control/indicator A1
Transport does not accept commands	Improper interface	Check interface with DTL logic and correct as necessary
	More than one command true simultaneously	Enable only desired command; hold other inputs high
Tape continues to advance during Load mode	No BOT marker on tape	Affix marker to tape approximately 12 ft. from physical beginning of tape; place marker near reference edge on backing side of tape
Tape tensioned but does not advance when capstan turns	Tape not threaded over capstan properly	Rethread tape (see Section III)
Tape tensioned but slips	Dirty capstan	Clean capstan in accordance with Section V
Tape moves during a stop condition	Defective capstan assembly	Replace capstan assembly and realign servo
	Motor voltage not zero	Check capstan servo and adjust for zero offset; repair if adjustment does not correct
Tape not tensioned or tape is spilled when Ready mode is set	Improper tape threading	See Section III
	Reel servo or motor malfunctioning	Replace motor or repair reel servo

Table 6-1. Common Problems

TROUBLE	PROBABLE CAUSE	REMEDY
Transport responds to write commands but tape is not written	Writer current not enabled	Check for write enable ring on reel; check write current command path to tape head; check that read is not enabled
Computer does not read tapes correctly	Data format incorrect	Use correct format
	Record length exceeds computer memory capability	Use correct record length

Table 6-1. Common Problems (Continued)

TROUBLE	PROBABLE CAUSE	REMEDY
Tape does not tension, and capstan shaft rotates freely when LOAD control is depressed for first time after tape is threaded	LOAD control not operative	Check operation of LOAD control A2; replace if necessary
Tape is tensioned when LOAD control is depressed, but tension is lost when control is released	Limit switch not operative	Adjust as described in Section V; possibly replace limit switch assembly
Tape unwinds or tension arm hits stop when LOAD control is depressed for first time	Tape improperly threaded	Rethread tape (see Section III)
	+ 5 volts missing from tension arm sensor	Check tension arm sensor lamps; isolate problem if lamp is extinguished
	Fault in reel servoamplifier	Troubleshoot reel servo and repair as necessary
Tape "runs away" or rewinds when LOAD control depressed second time	Fault in control logic or capstan motor assembly	Repair control/servo board or capstan motor assembly
Tape runs past BOT marker	BOT tab dirty or tarnished	Replace tab or increase sensitivity of photosensor amplifier (see Section V)
	Photosensor not properly adjusted	Adjust photosensor amplifier (Section V)
	Photosensor or amplifier defective	Replace or repair photosensor assembly
	Logic fault (load flip-flop does not reset)	Repair control/servo board

Table 6-2. System Troubleshooting

TROUBLE	PROBABLE CAUSE	REMEDY
Transport does not move tape in response to FORWARD or REVERSE commands	Interface cable fault or receiver fault	Check levels at outputs and inputs of receivers on control/servo board; replace or repair cable or repair control/servo board
	Transport not in Ready mode	Bring tape to load point (Section III)
	Fault in ramp generator or capstan servoamplifier	Repair control/servo or power board
Transport responds to remote FORWARD command, but tape is not written	Write current is not enabled	Check presence of write enable ring on supply reel; WRT EN indicator should be illuminated. Check for +5V on write board while writing; if not present, check for +5V at J20, pin 1. Also check J7, pin 1, on control/servo board and TP105 on power board
	Write Enable signal not correct	Check receiver on control/servo board; check for $\overline{\text{RUN}}$ signal on read/write board; repair read/write or control/servo board if faulty
	Write data or write data strobe not received correctly from interface	Check presence of correct levels on write portion of read/write board; repair write portion of read/write board or interface cable if faulty
	Heads not plugged in correctly	Check J21 on data board
Data are incorrectly written	Incorrect data format	Use correct format (see Section IV)
	Fault on one track due to failure in write circuits	Check receiver and write amplifier on write portion of data board; repair if faulty
	Intermittent +5V, $\overline{\text{RUN}}$, or WARS	Examine signals and repair control/servo or data board, as required
	Head and guides need cleaning	Clean head and guides
	Tape cleaner needs emptying	Remove tape cleaner and clean

Table 6-2. System Troubleshooting (Continued)

TROUBLE	PROBABLE CAUSE	REMEDY
Tape cannot be read	Interface cable or transmitter faulty	Replace or repair interface cable or transmitter on read/write board
	Head not plugged in	Check J22 on data board
	Read skew out of adjustment	Readjust in accordance with Section V
	Head and guides need cleaning	Clean head and guides
	Tape cleaner needs emptying	Remove tape cleaner and clean
	Read amplifier gains incorrectly adjusted	Check and adjust amplifier gains
	Other component fault in read channel	Check test point data; repair data board

Table 6-2. System Troubleshooting (Continued)

A JAG PER DSR #7
 B UPDATED DSR #7
 C ECR 11/67
 D ECO 154B
 E INCORP ECO 702B
 F INCORP ECO 1016B

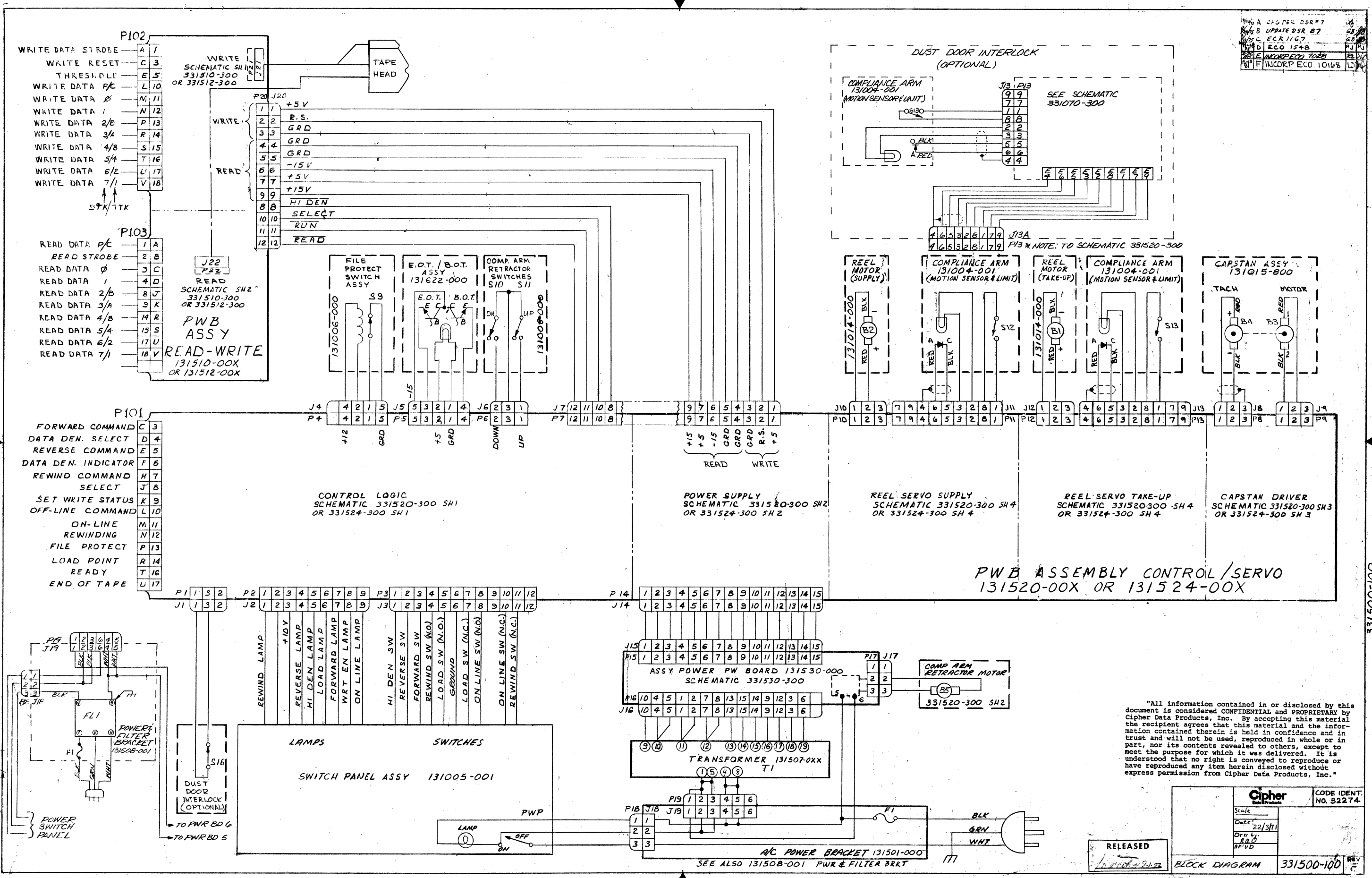

PWB ASSEMBLY CONTROL/SERVO
 131520-00X OR 131524-00X

"All information contained in or disclosed by this document is considered CONFIDENTIAL and PROPRIETARY by Cipher Data Products, Inc. By accepting this material the recipient agrees that this material and the information contained therein is held in confidence and in trust and will not be used, reproduced in whole or in part, nor its contents revealed to others, except to meet the purpose for which it was delivered. It is understood that no right is conveyed to reproduce or have reproduced any item herein disclosed without express permission from Cipher Data Products, Inc."

Cipher Data Products		CODE IDENT. NO. 32274
Scale Date: 22/3/11 Drawn by: RAO App'd by:	BLOCK DIAGRAM 331500-100	

RELEASED
 22/3/11

331500-100

"All information contained in or disclosed by this document is considered CONFIDENTIAL and PROPRIETARY by Cipher Data Products, Inc. By accepting this material the recipient agrees that this material and the information contained therein is held in confidence and in trust and will not be used, reproduced in whole or in part, nor its contents revealed to others, except to meet the purpose for which it was delivered. It is understood that no right is conveyed to reproduce or have reproduced any item herein disclosed without express permission from Cipher Data Products, Inc."

REVISION					
LTR	DESCRIPTION	OWN	DATE	APVD	DATE
A	ENGR - RELEASE	RA	7/17/80	MT	11/1/80
B	INCORP ECD 11629	EC	11/14/80	ST	11/22/80
C	INCORP ECD 12216	EC	11/14/80	ST	11/18/80
D	INCORP ECD 12427	UA	11/14/80	ST	11/22/80
E	INCORP ECD 13508	UA	11/14/80	ST	11/22/80
F	INCORP ECD 13812	UA	11/14/80	ST	11/22/80
G	INCORP ECD 14491	UA	11/14/80	ST	11/22/80
H	INCORP ECD 16755	NH	11/14/80	ST	11/22/80

- FACADE (21)
- SCREW (7) (82)
- TOP PLATE (1)

- REEL HUB ASSY (4)
- 2 PLACES
- HEIGHT TO BE .395 ± .005

- REEL (62)

- ROLLER TAPE GUIDE, SI. (47)
- SHIM (41)
- SHIM (42)
- SHIM (43)
- SHIM (44)
- SHIM (49)
- SHIM (50)
- SCREW (92)
- WASHER, FL. (78)
- WASHER, SP.LK. (73)

- PIV ASSY (17)
- GUIDE (37)
- PLASTIC CEMENT (67)
- FILE PROTECT SW. ASSY (16)
- SCREW (2) (84)
- WASHER, FL. (2) (75)
- WASHER, SP.LK. (2) (72)
- DOOR STAY ASSY (24)
- SHOULDER, SCREW (2) (102)
- WASHER NYLON (103)
- WASHER, FL. (77)
- 2 PLACES

- ROLLER TAPE GUIDE ST. (47)
- SHIM (41)
- SHIM (42)
- SHIM (43)
- SHIM (44)
- SHIM (49)
- SHIM (50)
- SCREW (92)
- WASHER, FL. (78)
- WASHER, LK. (73)
- 2 PLACES

- LABEL - CAPSTAN (26)

- CAP, CAPSTAIN SLEEVE (36)
- CAPSTAIN, LOW INERTIA (45)
- SCREW (93)
- SHIM (52)
- SHIM (53)
- SHIM (54)

SEE DETAIL SWITCHES (34/3)

- HEAD COVER, LEFT (31)
- BAYANA PLUG (2) (57)
- SCREW (2) (92)

- CATCH PIN (33)
- NUT, HEX (80)

- GROOVE PIN (.38 PROTRUSION) (91)

- EOT/BOT ASSY (20)
- SCREW (2) (84)

- REFLECTOR ASSY (21)
- SCREW (84)
- WASHER, SIM. OD. (79)

- TAPE SCRAPER ASSY (22)
- SCREW (2) (87)

- CABLE CLAMP (65)
- SCREW (89)
- WASHER, FL. (75)

- HEAD COVER, RIGHT (28)
- BAYANA PLUG (2) (57)
- SCREW (2) (92)

- TAPE GUIDE ASSY (12)
- 2 PLACES

- ROLLER TAPE GUIDE (48)
- SCREW (93)
- WASHER, SP.LK. (73)
- SHIM (41)
- SHIM (42)
- SHIM (43)
- SHIM (44)
- SHIM (49)
- SHIM (50)
- 2 PLACES

NOTES:

1. ITEMS NOT SHOWN: ITEM 5 - BACK MTG HDWR PKG, ITEM 34 - STEEL FRAME, ITEM 74, 77, 97 - QTY 4 - SHIPPING HARDWARE, ITEM 42 - SHIPPING CARTON.
2. FOR BLOCK DIAGRAM SEE 331500-100.
3. APPLY SCREW LOCITE, ITEM 69 AT INSTALLATION.
4. PWB EDGE CONNECTOR MUST BE CLEANED BEFORE INSTALLING CABLES.
5. IDENTIFY CONNECTIONS WITH COLOR DOT PER CONNECTOR COLOR CODE TABLE. SEE SH. 3.
6. TOP OF LABEL TO BE PARALLEL WITH TOP OF FACADE.
7. APPLY LUBRIPLATE, ITEM 68 ON SURFACE OF PUSH BAR AND IN MOUNTING HOLES OF CONNECTING ROD.
8. SHIM GUIDE AS REQUIRED.
9. THIS UNIT AT CONCLUSION OF MANUFACTURE PRIOR TO SHIPMENT SHALL BE DIELECTRIC TESTED PER PROCEDURE 600103-300.
10. WIRE THIS UNIT FOR THE VOLTAGE SPECIFIED ON SALES ORDER AND PER DWG 131507-002.
11. REMOVE RETAINING NUT AND SHIM BEFORE ASSY REF DWG 131075-101.
12. DO NOT TY-RAP RETRACTOR MOTOR AC WIRES, REF J17 TO BUNDLE OF LOGIC WIRES.

131000-996
REV H

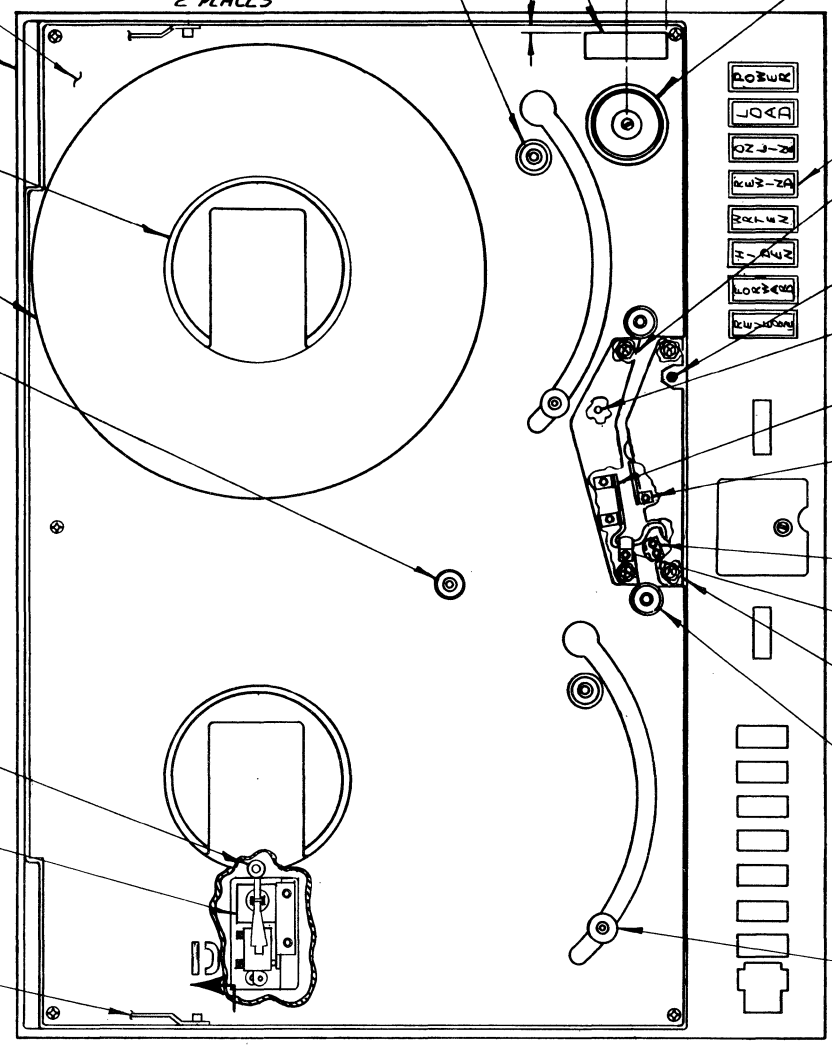

FRONT VIEW

REV	SHT	1	2	3
STATUS	REV	H	B	C

UNLESS OTHERWISE SPECIFIED DIMENSIONS ARE IN INCHES DECIMALS ANGLES	APPROVALS	DATE	
<small>UNLESS OTHERWISE SPECIFIED DIMENSIONS ARE IN INCHES DECIMALS ANGLES</small> XX = ± .02 XXX = ± .005	DWN: <i>R. Abad</i> CHK: <i>R. Abad</i> ENGR: <i>G. P. McK...</i> ELEC ENGR: <i>...</i> MFG ENGR: <i>...</i> QC: <i>R. McK...</i> DOC: <i>...</i>	7-17-80 11-10-80 11-17-80 11-17-80 11-17-80 11-17-80	

"Use or disclosure of information contained herein is subject to the restriction on the title page of this document."

REVISION				
LTR	DESCRIPTION	DWN	DATE	APVD
	SEE SHEET 1			

D
C
B
A

D
C
B
A

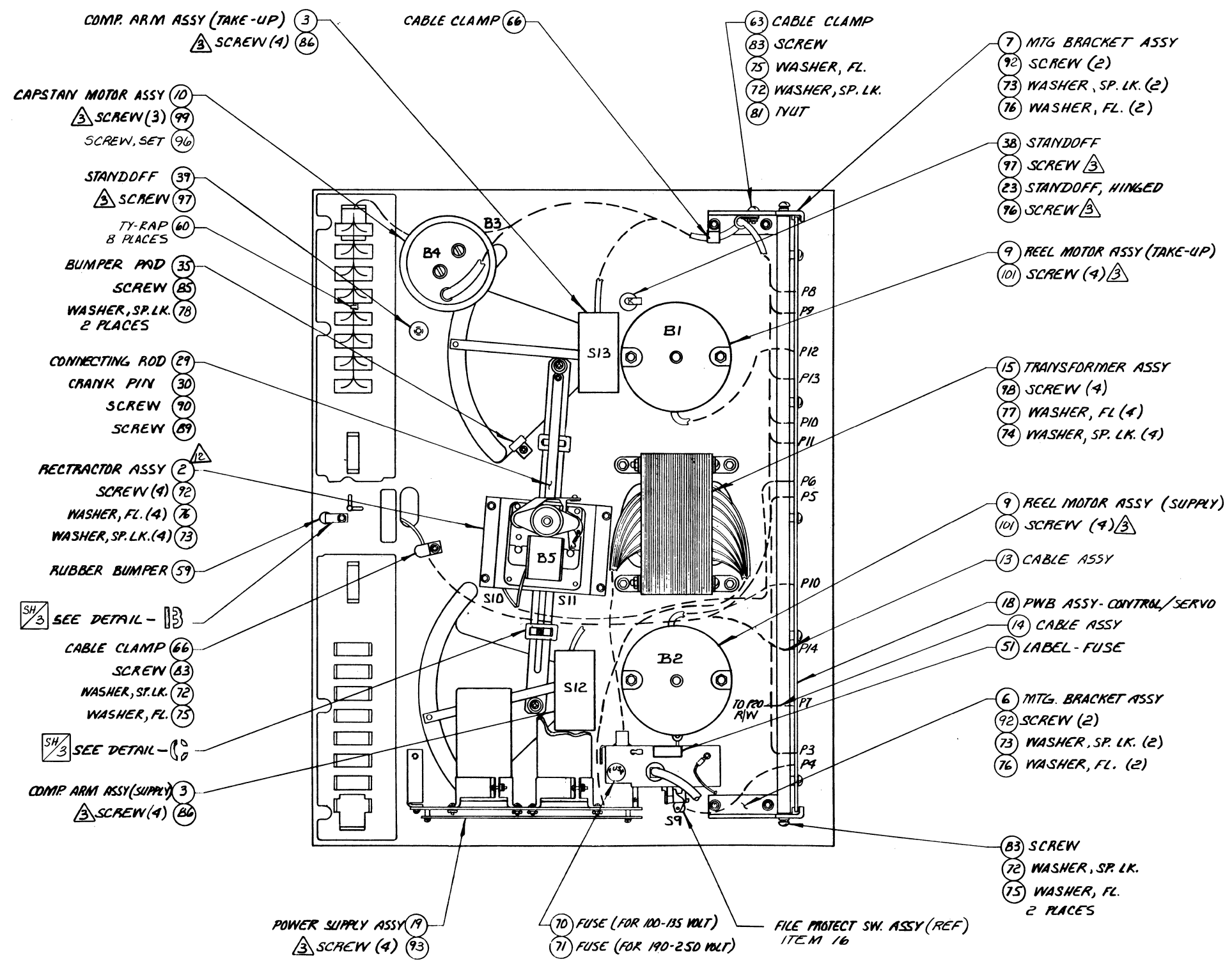

131000-996
REV B

REAR VIEW

UNLESS OTHERWISE SPECIFIED DIMENSIONS ARE IN INCHES DECIMALS 25 = 2 300 = 2		APPROVALS DWN R. Abad CHK	DATE 7-11-80		TITLE TOP PLATE ASSY- 100X DIECAST
MECH	ELC	SEC	QC		
DO NOT SCALE DRAWING				CODE IDENT NO. 131000-996	DRAWING NO. 131000-996
				SHEET 2 OF 2	REV B

"Use or disclosure of information contained herein is subject to the restriction on the title page of this document."

REVISION				
LTR	DESCRIPTION	DWN	DATE	APVD
	SEE SHEET 1			

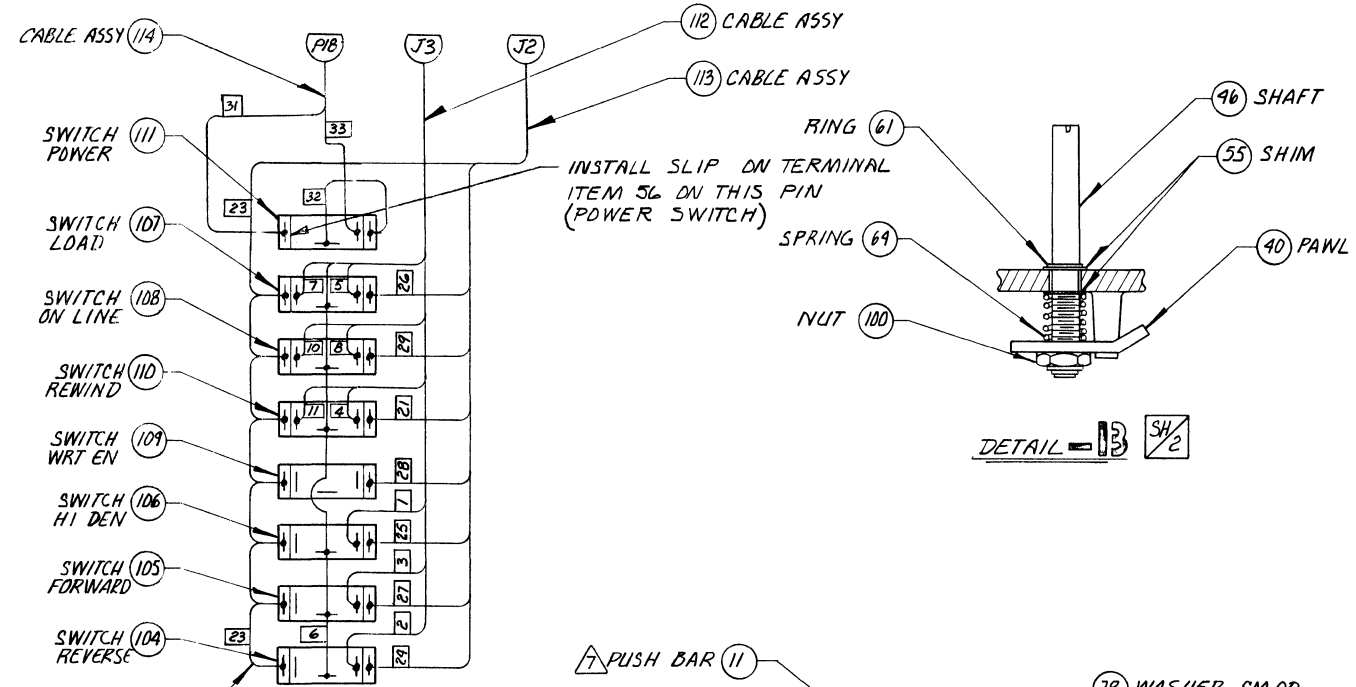

CONNECTOR COLOR CODE

FROM	TO		
CONN	COLOR	CONN	COLOR
J1	RED	---	---
J2	YELLOW	CONTROL/SW'S	---
J3	RED	CONTROL/SW'S	---
J4	RED	S9	---
J5	RED	EOT/BOT	---
J6	GREEN	S10 & S11	---
J7	YELLOW	J20	GREEN
J8	RED	B4	---
J9	YELLOW	B3	---
J10	BLACK	B2	---
J11	GREEN	S12	---
J12	BLUE	B1	---
J13	BLACK	S13	---
J14	YELLOW	J15	RED
J16	YELLOW	T1	---
J17	ORANGE	B5	---
J18	BROWN	CONTROL/SW'S	---
J19	RED	T1	---
J21	RED	TAPE HEAD	---
J22	YELLOW	TAPE HEAD	---

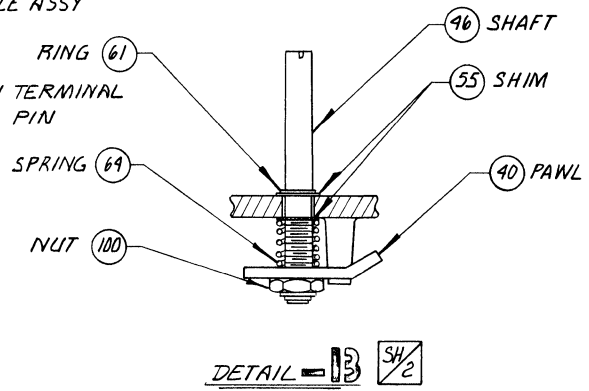

SWITCH ASSY WIRING REAR VIEW SHOWN
WIRE THIS EDGE MUST NOT PROTRUDE BEYOND END OF SWITCHES

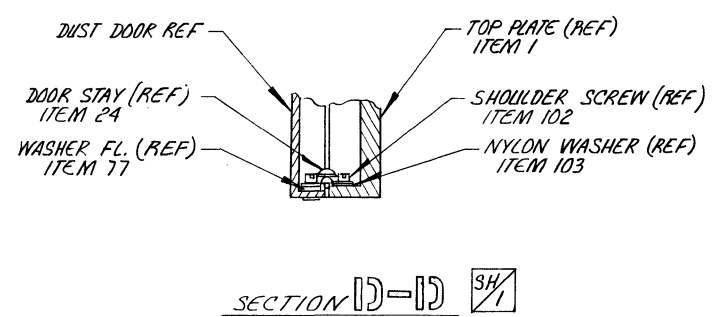
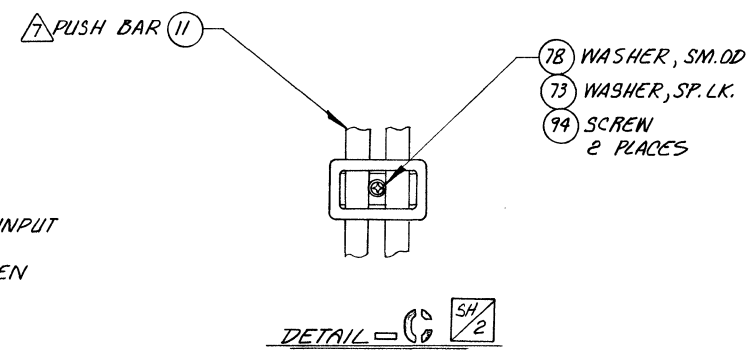
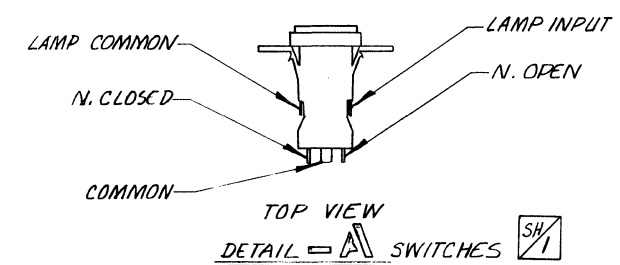

131000-996
REV C

UNLESS OTHERWISE SPECIFIED DIMENSIONS ARE IN INCHES TOLERANCES ARE: DECIMALS ANGLES DWN R. Abad	APPROVALS	DATE	CIPHER SAN DIEGO CALIF. Data Products
	CHK		
MECH ENG			SIZE CODE IDENT NO. DRAWING NO. REV
ELEC ENG			D 32274 131000-996 C
MFG ENG			SCALE NONE SHEET 3 OF 3
QC			
DO NOT SCALE DRAWING	DOC CHK		

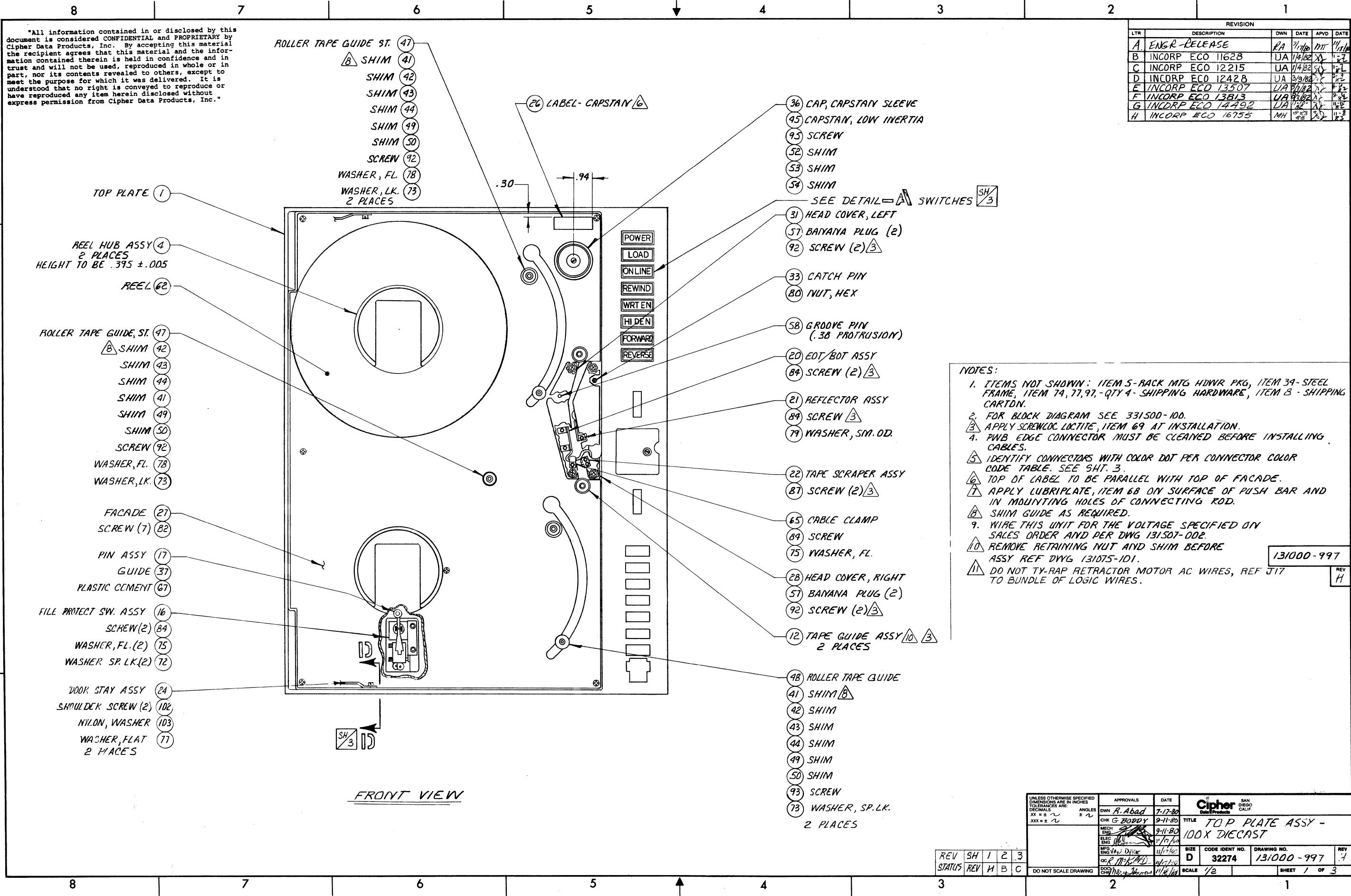

"All information contained in or disclosed by this document is considered CONFIDENTIAL and PROPRIETARY by Cipher Data Products, Inc. By accepting this material the recipient agrees that this material and the information contained therein is held in confidence and in trust and will not be used, reproduced in whole or in part, nor its contents revealed to others, except to meet the purpose for which it was delivered. It is understood that no right is conveyed to reproduce or have reproduced any item herein disclosed without express permission from Cipher Data Products, Inc."

REVISION					
LTR	DESCRIPTION	DWN	DATE	APVD	DATE
A	ENGR-RELEASE	RA	7/17/80	MT	11/16/80
B	INCRP ECO 11628	UA	1/4/82	SY	1-7
C	INCRP ECO 12215	UA	1/4/82	SY	1-7
D	INCRP ECO 12428	UA	3/9/82	SY	1-7
E	INCRP ECO 13507	UA	8/18/82	SY	1-7
F	INCRP ECO 13813	UA	8/18/82	SY	1-7
G	INCRP ECO 14492	UA	1/22/83	AF	1-7
H	INCRP ECO 16755	MH	6/23/83	SY	11-8

- NOTES:
- ITEMS NOT SHOWN: ITEM 5-BACK MTG HDWR PKG, ITEM 39-STEEL FRAME, ITEM 74,77,97,-QTY 4- SHIPPING HARDWARE, ITEM 8- SHIPPING CARTON.
 - FOR BLOCK DIAGRAM SEE 331500-100.
 - APPLY SCREWCLOC LOCTITE, ITEM 69 AT INSTALLATION.
 - PWB EDGE CONNECTOR MUST BE CLEANED BEFORE INSTALLING CABLES.
 - IDENTIFY CONNECTORS WITH COLOR DOT PER CONNECTOR COLOR CODE TABLE. SEE SHT. 3.
 - TOP OF LABEL TO BE PARALLEL WITH TOP OF FACADE.
 - APPLY LUBRIPLATE, ITEM 68 ON SURFACE OF PUSH BAR AND IN MOUNTING HOLES OF CONNECTING ROD.
 - SHIM GUIDE AS REQUIRED.
 - WIRE THIS UNIT FOR THE VOLTAGE SPECIFIED ON SALES ORDER AND PER DWG 131507-002.
 - REMOVE RETAINING NUT AND SHIM BEFORE ASSY REF DWG 131075-101.
 - DO NOT TY-RAP RETRACTOR MOTOR AC WIRES, REF J17 TO BUNDLE OF LOGIC WIRES.

131000-997
REV H

UNLESS OTHERWISE SPECIFIED DIMENSIONS ARE IN INCHES TOLERANCES ARE DECIMALS .XX ± .02 ANGLES ± .2		APPROVALS		DATE	CIPHER SAN DIEGO CALIF.	
DWN	R. Abad	7-17-80			TITLE TOP PLATE ASSY - 100X DIECAST	
CHK	G. BODDY	9-11-80			SIZE CODE IDENT NO. DRAWING NO. REV	
MECH		9-11-80			D 32274 131000-997 H	
ELEC		11/17/80			SCALE 1/2 SHEET 1 OF 3	
ENG		11/17/80			DO NOT SCALE DRAWING	
APP		11/17/80				
DOC		11/16/80				

REV	SH	1	2	3
STATUS	REV	H	B	C

FRONT VIEW

"Use or disclosure of information contained herein is subject to the restriction on the title page of this document."

REVISION				
LTR	DESCRIPTION	DWN	DATE	APVD
	SEE SHEET 1			

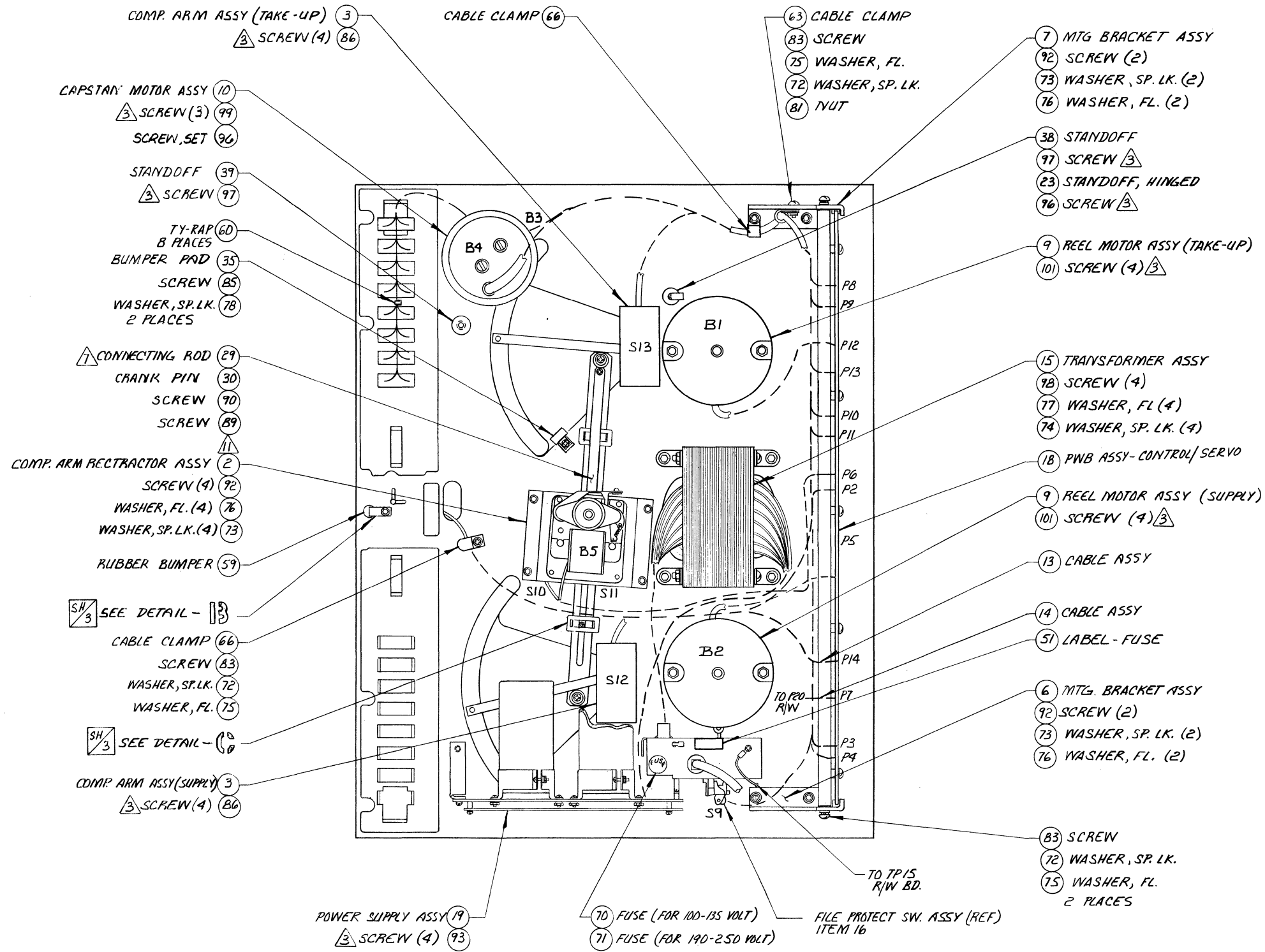

REAR VIEW

131000-997
REV B

UNLESS OTHERWISE SPECIFIED DIMENSIONS ARE IN INCHES TOLERANCES ARE: DECIMALS .XX = ± .02 ANGLES ± .2		APPROVALS	DATE	
CHK	DWN	R. Abad	7-17-80	
MECH ENG				TITLE
ELEC ENG				TOP PLATE ASSY-100X DIECAST
MFG ENG				SIZE
QC				D
DOC CHK				CODE IDENT NO.
				32274
				DRAWING NO.
				131000-997
				SCALE
				1/2
				SHEET
				2 OF 3

"Use or disclosure of information contained herein is subject to the restriction on the title page of this document."

REVISION				
LTR	DESCRIPTION	DWN	DATE	APVD
	SEE SHEET 1			

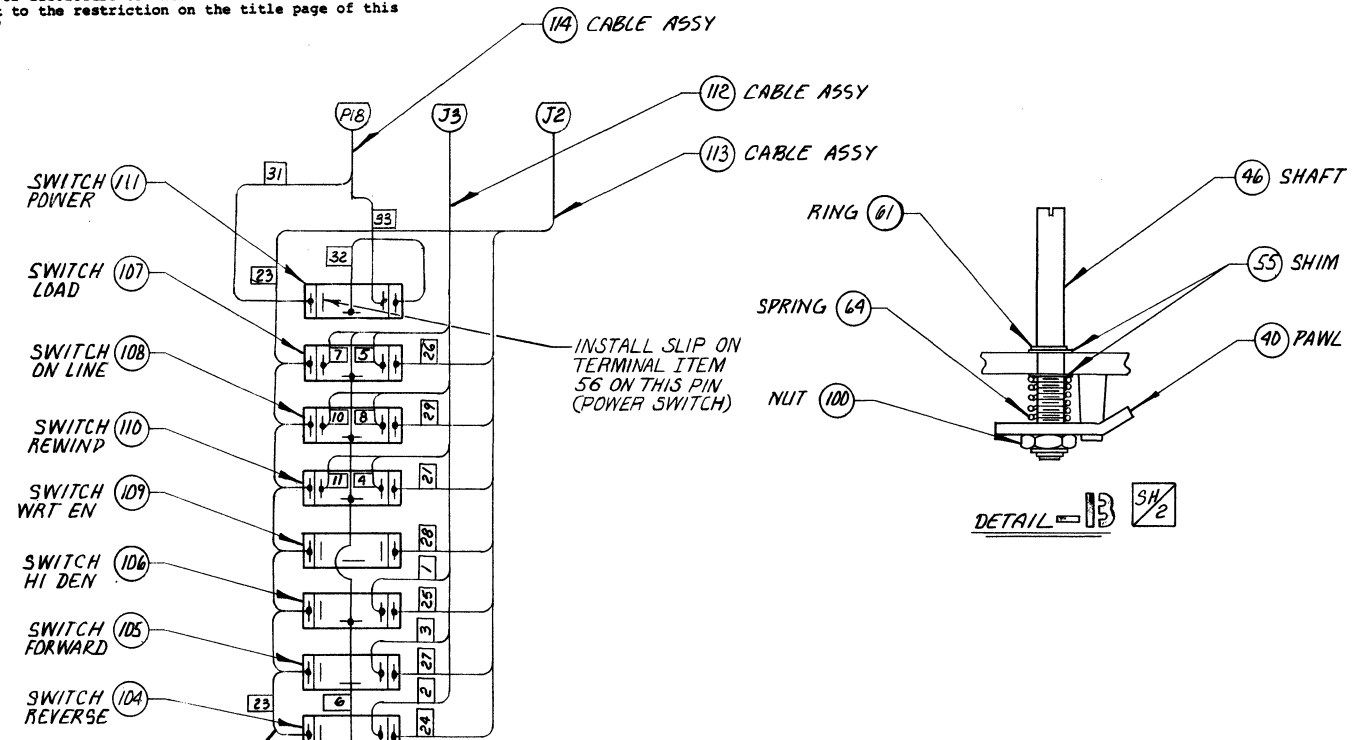

FROM		TO	
CONN	COLOR	CONN	COLOR
J1	RED	—	—
J2	YELLOW	CONTROL/SW'S	—
J3	RED	CONTROL/SW'S	—
J4	RED	S9	—
J5	RED	EOT/BOT	—
J6	GREEN	S10&S11	—
J7	YELLOW	J20	GREEN
J8	RED	B4	—
J9	YELLOW	B3	—
J10	BLACK	B2	—
J11	GREEN	S12	—
J12	BLUE	B1	—
J13	BLACK	S13	—
J14	YELLOW	J15	RED
J16	YELLOW	T1	—
J17	ORANGE	B5	—
J18	BROWN	CONTROL/SW'S	—
J19	RED	T1	—
J21	RED	TAPE HEAD	—
J22	YELLOW	TAPE HEAD	—

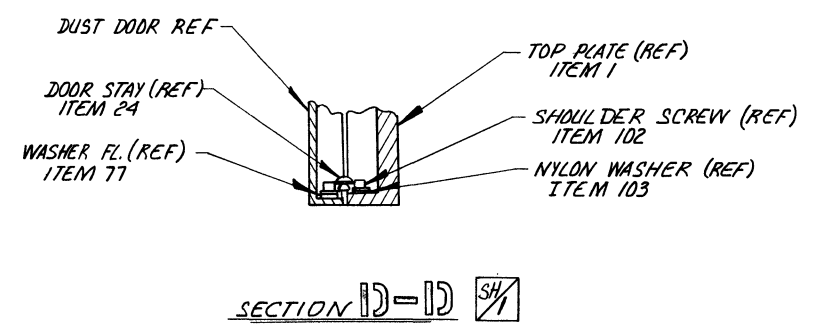
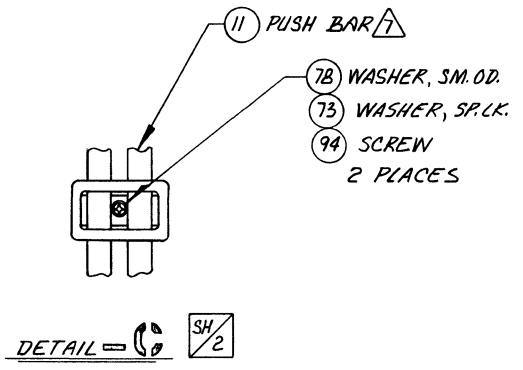
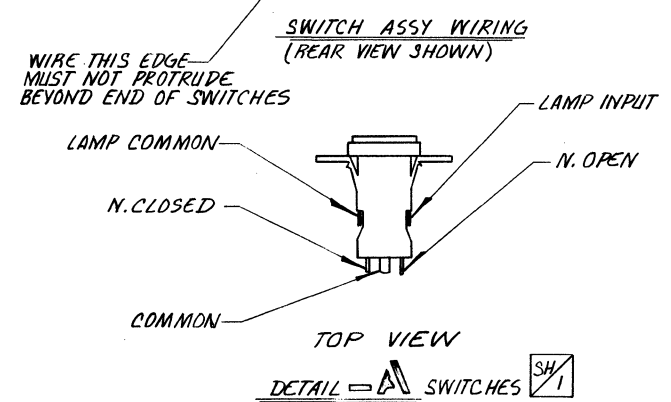

131000-997
REV C

UNLESS OTHERWISE SPECIFIED DIMENSIONS ARE IN INCHES TOLERANCES ARE: DECIMALS .XX ± .01 ANGLES ± .1		APPROVALS		DATE	Cipher SAN DIEGO CALIF. Data Products
DO NOT SCALE DRAWING		DWN FABAO			
		MECH ENG			TITLE TOP PLATE ASSY - 100X DIECAST
		ELEC ENG			SIZE D CODE IDENT NO. 32274 DRAWING NO. 131000-997
		MFG ENG			REV C
		QC			SCALE NONE SHEET 3 OF 3

DATE	SYM	REVISION	RECORD	DR'NCK'D
9/73	E	CHG'D PER ECR # 277		J-C
10/73	F	ECR # 361		JA
11/73	G	ECR # 389		JA
12/73	H	ECR # 57		CEB
1/74	J	ECR 437, 457		CEB
2/74	K	ECR 1045, 1097		HJ
3/74	L	ECR 1140		GB
4/74	M	ECR 1057		GB
5/74	N	ECR 1204		HJ
6/74	P	ECO 1369		HJ
7/74	R	ECO 1763		HJ
8/74	S	ECO 2284		DS
9/74	T	ECO 2490		DS
10/74	U	ECO 2601		WH
11/74	V	ECO 2776		MC
12/74	W	INCORP ECO 3212		RA
1/75	Y	INCORP ECO 3298		RA
2/75	Z	INCORP ECO 35		TW
3/75	AA	INCORP ECO 3966		RA
4/75	AB	INC ECO 5711		CH
5/75	AC	INC ECO 5961		CH
6/75	AD	INC ECO 6136		CH
7/75	AE	INCORP ECO 6298		LJ
8/75	AF	INCORP ECO 7902		LJ
9/75	AG	INCORP ECO 8991		LJ
10/75	AH	INCORP ECO 12975		ECW
11/75	AI	INCORP ECO 1568		SS
12/75	AJ	INCORP ECO 14595		SS
1/76	AK	INCORP ECO 15383		EC
2/76	AM	INCORP ECO 16673		EC

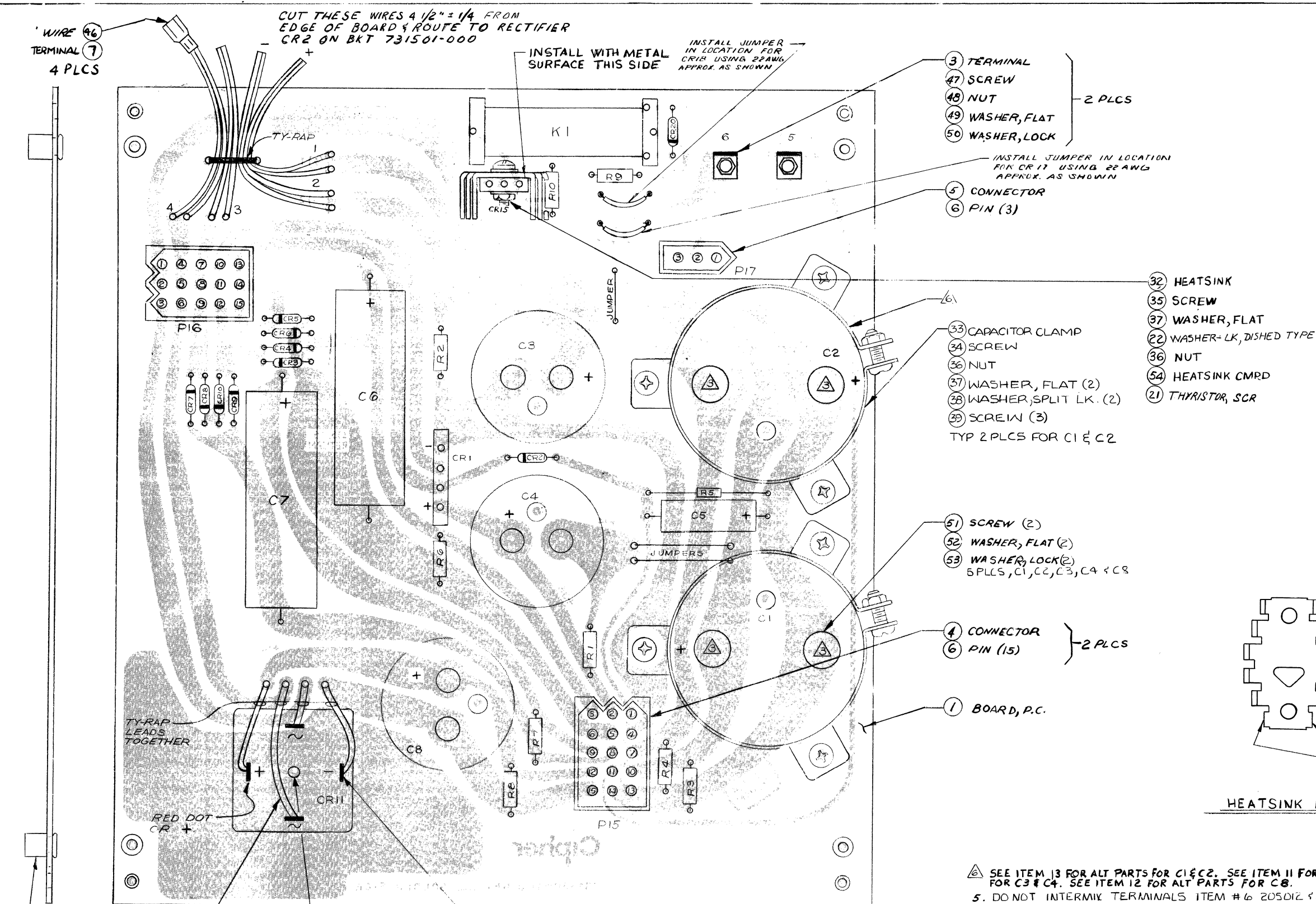

"All information contained in or disclosed by this document is considered CONFIDENTIAL and PROPRIETARY by Cipher Data Products, Inc. By accepting this material the recipient agrees that this material and the information contained therein is held in confidence and in trust and will not be used, reproduced in whole or in part, nor its contents revealed to others, except to meet the purpose for which it was delivered. It is understood that no right is conveyed to reproduce or have reproduced any item herein disclosed without express permission from Cipher Data Products, Inc."

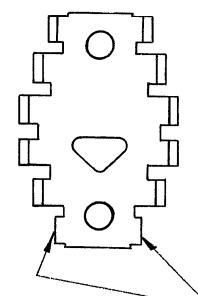

REMOVE THESE TWO TABS. INSTALL THIS SIDE DOWN, NEXT TO BOARD.
HEATSINK MODIFICATION (FOR CR15)

- 1. SEE ITEM 13 FOR ALT PARTS FOR C1 & C2. SEE ITEM 11 FOR ALT PARTS FOR C3 & C4. SEE ITEM 12 FOR ALT PARTS FOR C8.
- 2. DO NOT INTERMIX TERMINALS ITEM #6 205012 & ALT PART 205012-001 IN ONE CONNECTOR.
- 3. FOR SCHEMATIC SEE DWB 331530-300.
- 4. THE HOLE SPACING OF C1 & C2 CAN BE VARIED FROM .750" TO 1.15" TO ALLOW FOR CAPACITOR TYPE VARIANCES.
- 5. IDENTIFY EACH CONNECTOR WITH A COLORED PAINT DOT AS FOLLOWS; P15=RED, P16=YELLOW, & P17=ORANGE.
- 6. CONNECTORS (ITEMS 4 & 5) MUST BE INSTALLED FLUSH TO P/C BOARD (.010 MAX. GAP).

CIPHER Data Products		SAN DIEGO CALIF	CODE IDENT NO. 32274
MODEL 100X	SCALE 2X	DRAWN BY J-C	
TITLE PWB ASSY-POWER SUPPLY		APPROVED BY CEB	
DATE 6AU673	DRAWING NUMBER 131530-000, -001	REV AM	

"All information contained in or disclosed by this document is considered CONFIDENTIAL and PROPRIETARY by Cipher Data Products, Inc. By accepting this material the recipient agrees that this material and the information contained therein is held in confidence and in trust and will not be used, reproduced in whole or in part, nor its contents revealed to others, except to meet the purpose for which it was delivered. It is understood that no right is conveyed to reproduce or have reproduced any item herein disclosed without express permission from Cipher Data Products, Inc."

REV	DESCRIPTION	DATE
1	REL FOR PROD	11/74
2	ECR 1141	11/74
3	ECR 1053	11/74
4	ECO 1248	11/74
5	ECO 2033	11/74
6	ECO 2489	11/74
7	INCORP ECO 9098	11/74
8	INCORP ECO 8852	11/74
9	REWORK ON INTD CONNECTED COMP	11/74
10	INC. ECO 8491	11/74
11	INC. ECO 16518	11/74

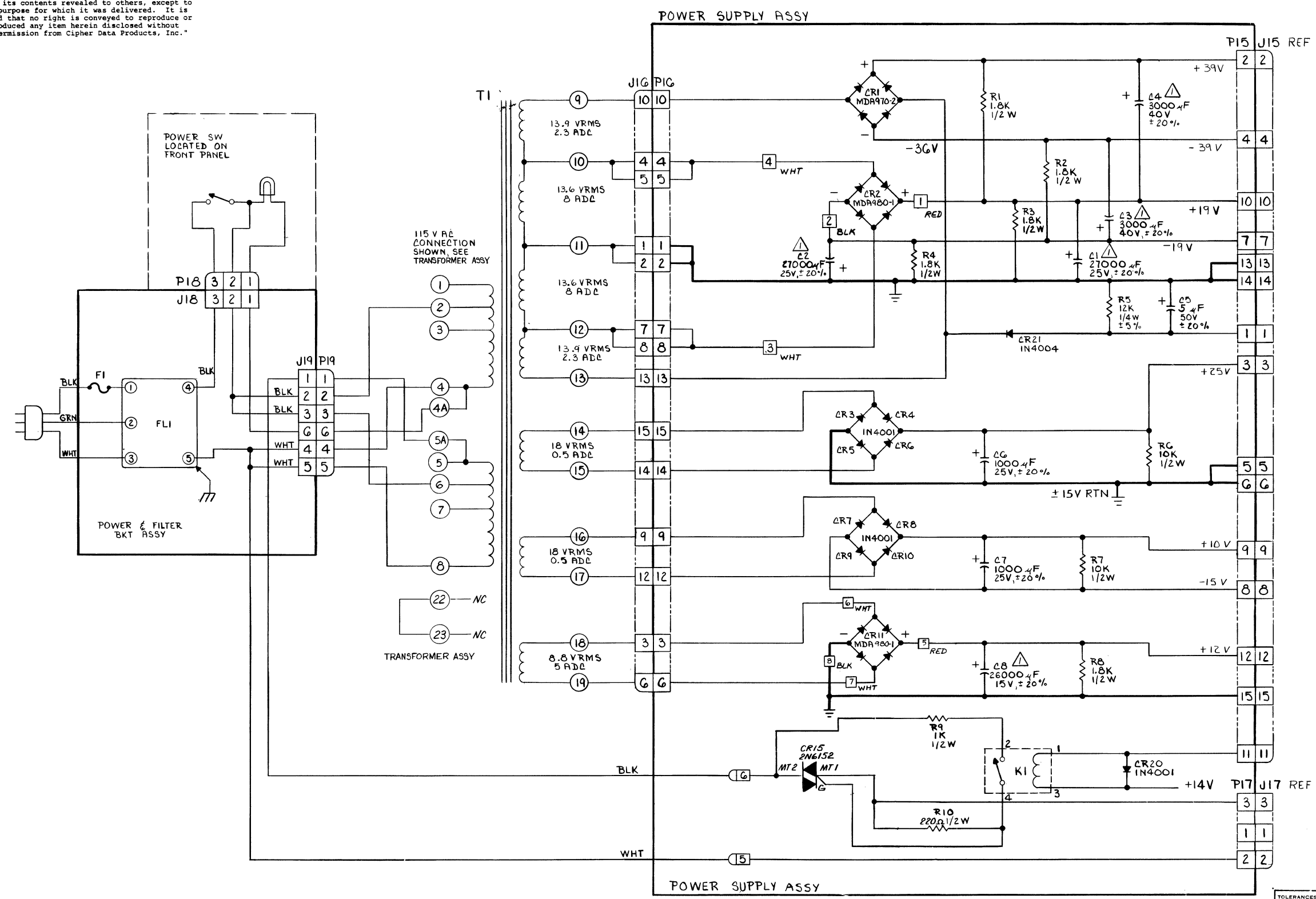

NOTES:
 △ SEE PARTS LIST FOR ALLOWABLE COMPONENT VALUE VARIATION.

RELEASED
 2-24-75
[Signature]

TOLERANCES (EXCEPT AS NOTED)	Cipher	SAN DIEGO CALIF.	CODE IDENT	NO. 32274
DECIMAL	MODEL 100X	NONE	SCALE	DRAWN BY <i>[Signature]</i>
FRACTIONAL	TITLE			APPROVED BY CEB
ANGULAR	DATE			REV
	1-22-75	331530-300		K

331530-300

"All information contained in or disclosed by this document is considered CONFIDENTIAL and PROPRIETARY by Cipher Data Products, Inc. By accepting this material the recipient agrees that this material and the information contained therein is held in confidence and in trust and will not be used, reproduced in whole or in part, nor its contents revealed to others, except to meet the purpose for which it was delivered. It is understood that no right is conveyed to reproduce or have reproduced any item herein disclosed without express permission from Cipher Data Products, Inc."

REVISION				REVISION			
LT	DESCRIPTION	DATE	APPROVAL	LT	DESCRIPTION	DWN	DATE
T	INCCORP ECO 11569 EC	1/2/81		A	ENGR. RELEASE	DP	1-30-80
U	INCCORP ECO 12806 UA	2/1/81		B	INCCORP ECO 7737	L3	1-2-80
V	INCCORP ECO 12889 UA	2/1/81		C	INCCORP ECO 7905	L3	1-2-80
W	INCCORP ECO 13022 UA	2/1/81		D	INCCORP ECO 8207	L3	1-2-80
X	INCCORP ECO 14216 EC	2/1/81		E	INCCORP ECO 8313	L3	10-23-80
Y	INCCORP ECO 14660 SS	2/1/81		F	INCCORP ECO 8493	L3	11-7-80
Z	INCCORP ECO 14970 EC	2/1/81		G	INCCORP ECO 8609	L3	12-18-80
AA	INCCORP ECO 14582 EC	2/1/81		H	INCCORP ECO 8946	L3	1-14-81
AB	INCCORP ECO 14848 EC	2/1/81		J	INCCORP ECO 8942	L3	2-5-81
AC	INCCORP ECO 15318 EC	2/1/81					
AD	INCCORP ECO 14483 EC	2/1/81					
AE	INCCORP ECO 14743 EC	2/1/81					

SOCKET (159)
RELAY (157)
CLIP (160)
INSTALL SOCKET INTO PWB PRIOR TO K2 & CLIP INSTALLATION.

(3) LABEL - MARK ASSY NO. & REV.

(188) WIRE-JUMPER, INSULATED (10)
AA-BB, FF-GG, KK-LL, P-N, MM-NN, RR-SS, YY-ZZ, \bar{X} - \bar{Y} , \bar{Z} - \bar{A} , \bar{B} - \bar{C} .

(17) SOCKET - INSTALL INTO PWB PRIOR TO U1 & U2 INSTALLATION

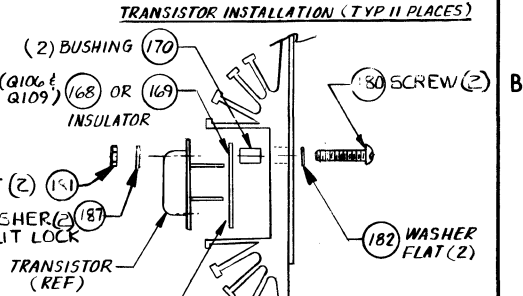
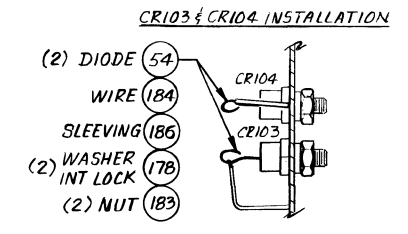
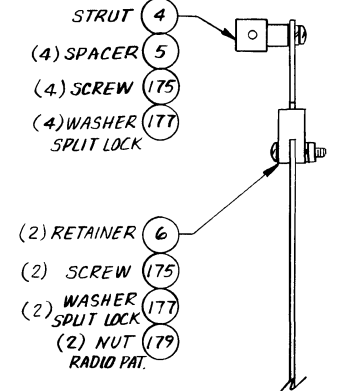

HEATSINK COMPOUND (171)
USE MINIMUM AMOUNT ON TRANSISTOR AND INSULATOR WHEN MTG ON HEATSINK.

TEST POINT (54)
PWB (1)
TRANSISTOR (5) (56)
HEATSINK (173) (6)
INSTALL AFTER PWB ASSY & INSPECTION.

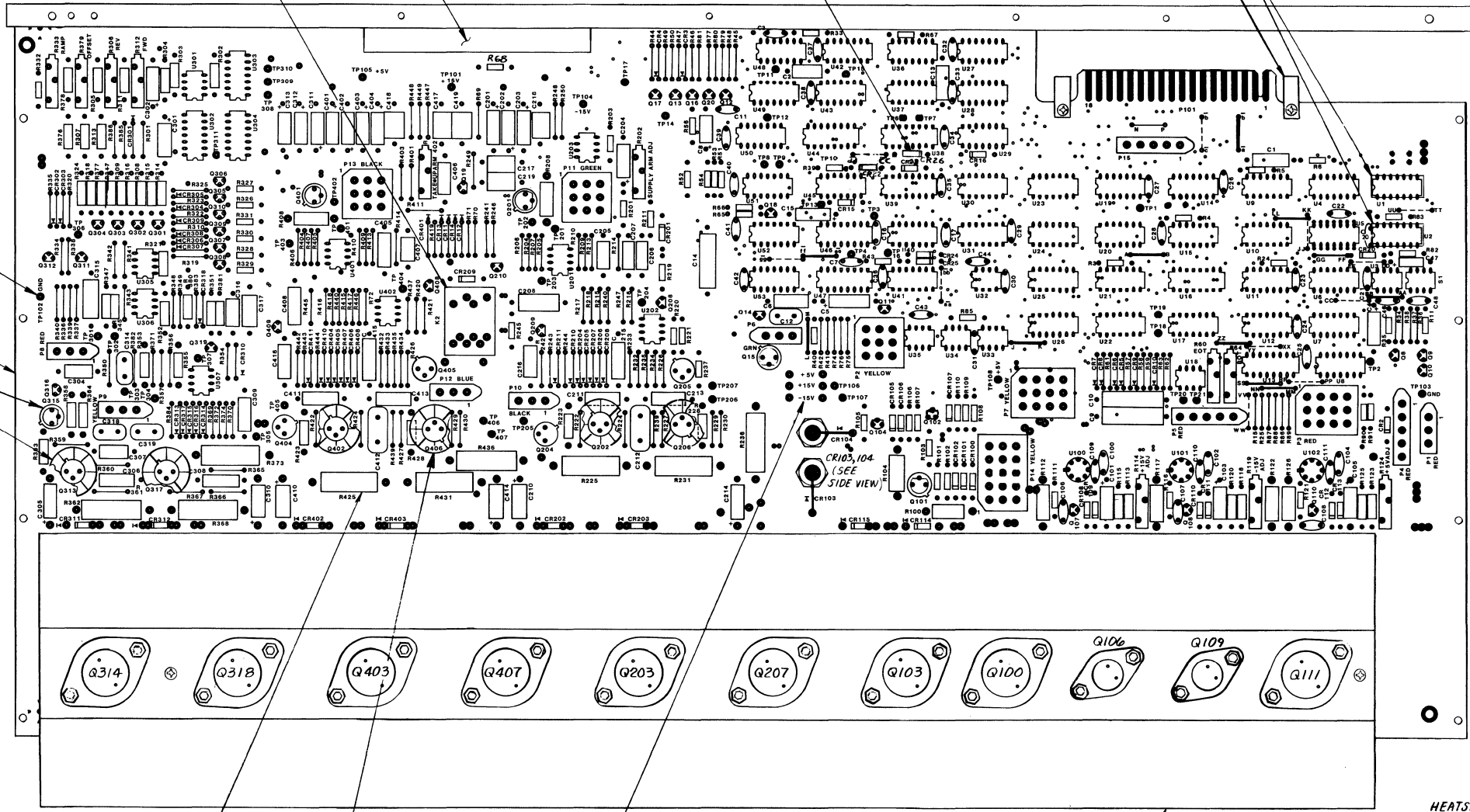

NOTES ~

1. WIRE WOUND RESISTORS (ITEMS 128, 129, 130, 131 & 138) TO BE INSTALLED AWAY FROM PWB THE THICKNESS OF THE COMPONENT.

2. ITEM 172 INSTALLED WITH ITEMS 64, 65, 191, 192 (TRANSISTORS)

3. DO NOT INTERMIX TERMINALS ITEM #16 (205012) & ALT PART (205012-001) IN ONE CONNECTOR.

(172) TRANSIPAD (6)

(188) WIRE-JUMPER, INSULATED (3)
INSTALL +5V, +15V, & -15V JUMPERS AFTER CHECKOUT OF RESPECTIVE REGULATOR.

(2) HEATSINK - ALIGN HOLES IN PWB TO HOLES IN HEATSINK.
(175) SCREW (2)
(177) WASHER SPLIT LOCK (2)
(179) NUT (2)

TRANSIPAD MUST BE USED WITH ALT. PART ITEM 56.

REWORK REQUIREMENTS	
DWG NO. & REV	ECO #
731580-101 REV K & PRIOR	16629 16793

APPROVALS		DATE	CIPHER DATA PRODUCTS	
OWN	D. PRESGOTT	1-30-80	SAN DIEGO	CALLIF
CHK	M. J. ...	2/2/81	TITLE: PWB ASSY - CONTROL/SERVO	
MFG	...	2-25-80	SIZE: CODE IDENT NO. 32274	
ENG	...	2-25-80	DRAWING NO. 131580-001-002	
DC	...	2/2/81	REV: AF	
DOC	...	2/2/81	SCALE: 1:1	
DO NOT SCALE DRAWING		SCALE: 1:1	SHEET 1 OF 1	

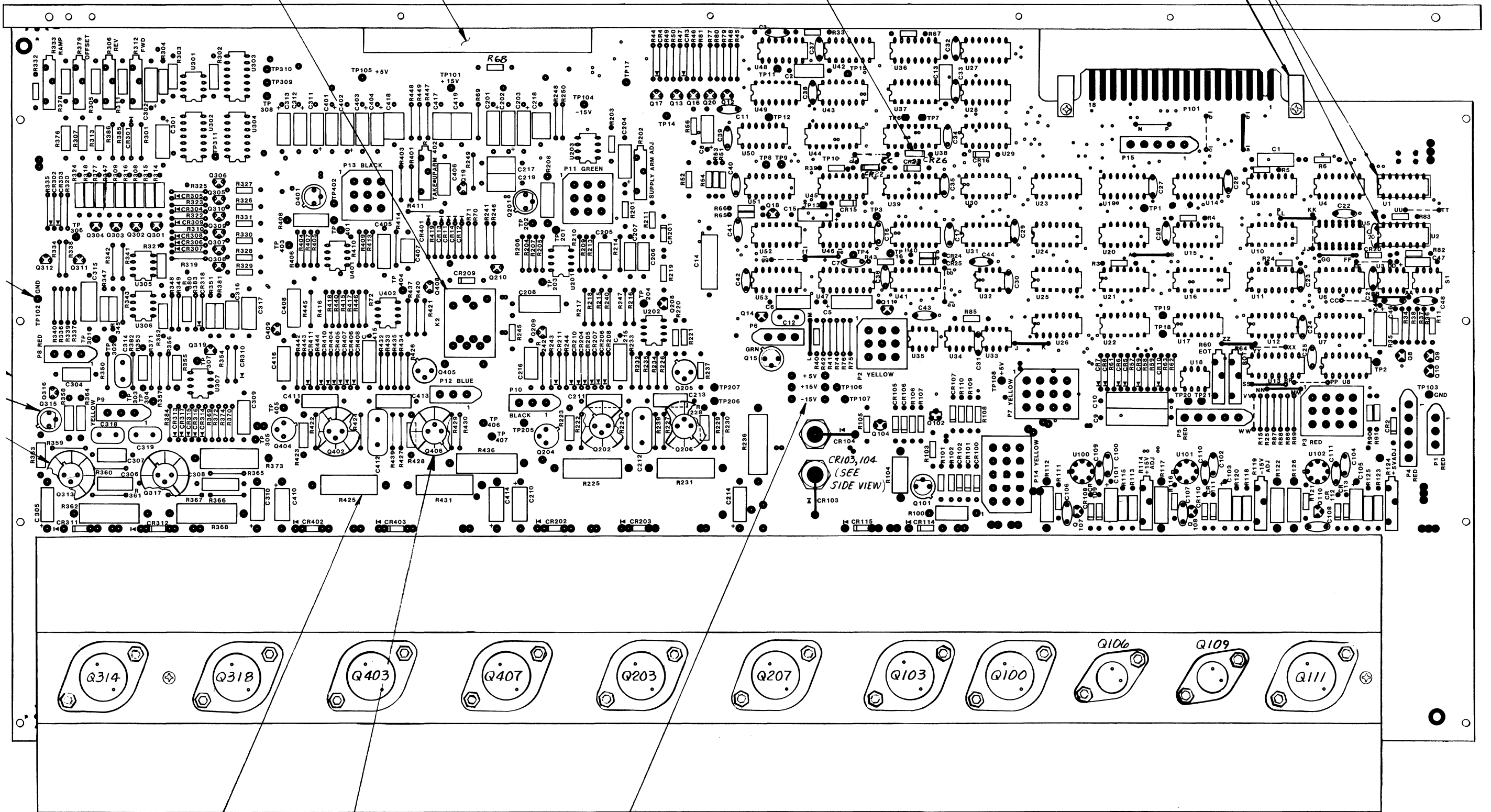

"All information contained in or disclosed by this document is considered CONFIDENTIAL and PROPRIETARY by Cipher Data Products, Inc. By accepting this material the recipient agrees that this material and the information contained therein is held in confidence and in trust and will not be used, reproduced in whole or in part, nor its contents revealed to others, except to meet the purpose for which it was delivered. It is understood that no right is conveyed to reproduce or have reproduced any item herein disclosed without express permission from Cipher Data Products, Inc."

REVISION					
LTR	DESCRIPTION	DWN	DATE	APVD	DATE
A	ENG RELEASE	DP	1-30-80	DP	2/1/80
B	INCORP ECO 8314	LJ	10-180		10-10
C	INCORP ECO 8494	LJ	11-5		11-10
D	INCORP ECO 8610	LJ	12-17		12-18
E	INCORP ECO 9363	LJ	2-3		2-7
F	INCORP ECO 9422	LJ	2-12		2-17
G	INCORP ECO 11570	EC	10/11/78		11-7
H	INCORP ECO 12807	UA	11/2/78		11-22
J	INCORP ECO 13280	EC	1/4/79		1-22
K	INCORP ECO 13911	EC	1/3/80		1-22
L	INCORP ECO 14193	EC	1/16/80		1-22

NOTES: UNLESS OTHERWISE SPECIFIED

1. RESISTOR VALUES ARE IN OHMS, 1/4W, 5%.
2. CAPACITOR VALUES ARE IN MICROFARADS, ±20%.
3. DIODES ARE IN 914.
4. CIRCLED LETTERS OR NUMBERS $\text{\textcircled{A}}$, CORRESPOND TO LIKE MARKING ON SHEET INDICATED.
5. IC POWER & GND PINS:

IC TYPE	REFERENCE DESIGNATOR	GND	+5V	UNUSED
UA555TC	U3	1	8	
9601PC	U7, 48	7	14	
SN7442N	U44	8	16	
SN7476N	U16, 38, 39	13	5	
SN74221N	U46, 47	8	16	
SN74279N	U13	8	16	
SN75451BP	U32, 33, 34, 35	4	8	
SN15830N	U43	7	14	
SN15836N	U4, 9, 11, 19, 31, 37, 49, 304	7	14	
SN15844N	U15, 17, 27, 36, 42	7	14	
SN15846N	U8, 10, 12, 14, 21-24, 26, 30, 41, 45, 50, 51, 53, 302, 303	7	14	U303-C, D
SN15862N	U6, 20, 25, 28, 29, 40, 52	7	14	
LM300H	U100, 101, 102	SEE SH 4		
N5558V	U18, 201, 202, 203, 301, 305, 306, 307, 401, 402	SEE SH 3, 5, 6 & 7		

6. LAST USED REFERENCE DESIGNATORS:

SH 2 & 3	SH 4	SH 5	SH 6	SH 7
C52	C111	C319	C419	C219
CR26	CR114	CR318	CR411	CR211
				K2
PI-7, 15, 101	PI4	PB, 9	PI3	PI0, 11, 12
Q20	Q111	Q319	Q409	Q210
R91	R126	R386	R449	R250
S1				
TP21	TP108	TP311	TP407	TP207
U53	U102	U307	U402	U203

331580-301

REV. LTR.	1	2	3	4	5	6	7
SHEET NO.	1	2	3	4	5	6	7

UNLESS OTHERWISE SPECIFIED DIMENSIONS ARE IN INCHES TOLERANCES ARE: .XX ± .0		APPROVALS	DATE	CIPHER DATA PRODUCTS SAN DIEGO CALIF.	
CHK	D. PRESCOTT	1-30-80	TITLE		
MECH		5-30-80	SCHEM -		
ENG		5-30-80	CONTROL/SERVO		
ELEC		5/31/80	SIZE	CODE IDENT NO.	DRAWING NO.
MFG	VAJ DIKE	5/14/80	D	32274	331580-301
OC	Paul	5/18/80	SCALE	NONE	SHEET 1 OF 7
DOC	CH/E	6/2/80			

REVISION				
LTR	DESCRIPTION	OWN	DATE	APVD
SEE SH. 1				

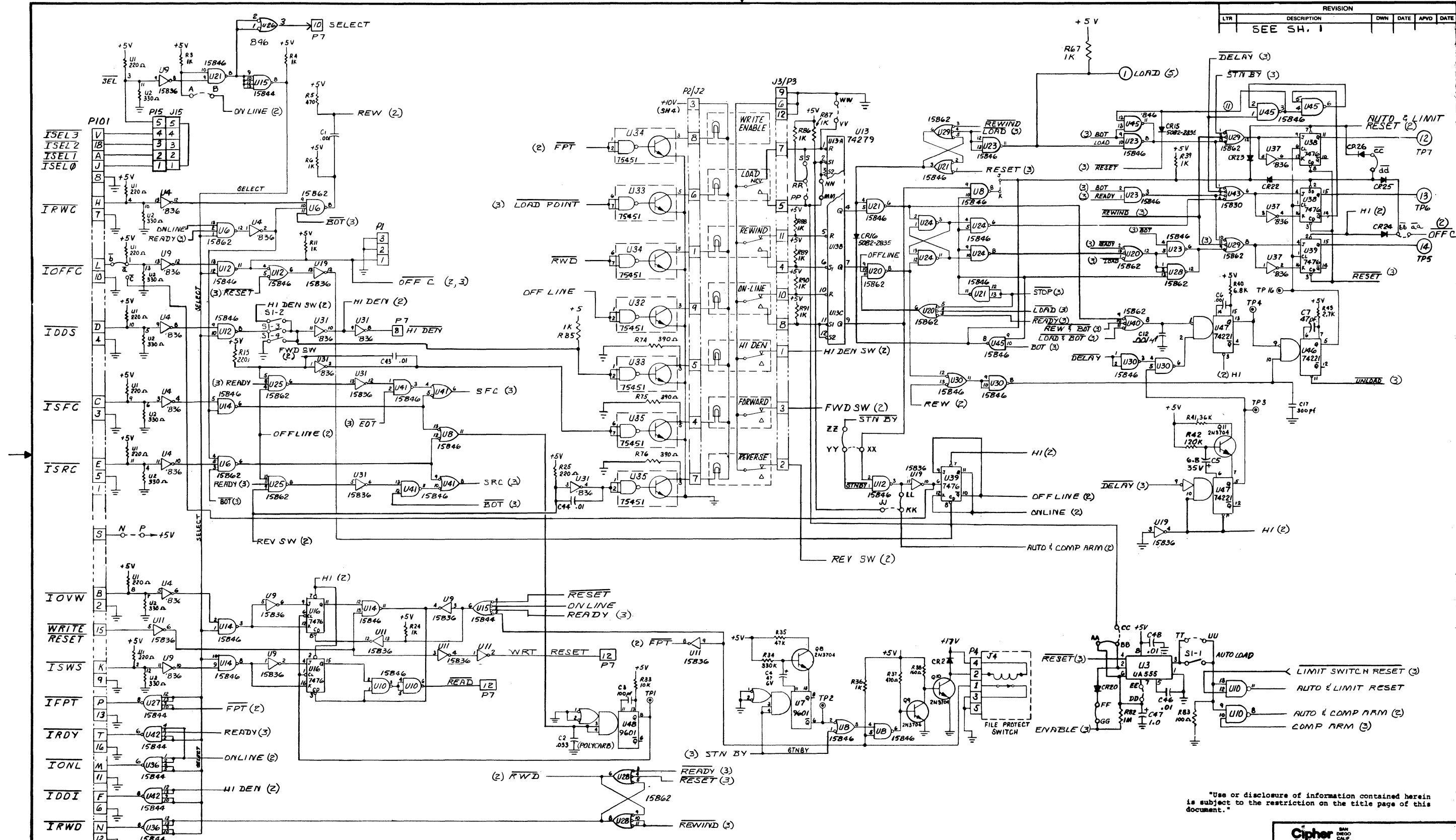

"Use or disclosure of information contained herein is subject to the restriction on the title page of this document."

Cipher		SAN DIEGO CALIF.	
TITLE SCHEM - CONTROL / SERVO			
SIZE D	CODE 32274	DRAWING NO. 331580-301	REV K
SCALE NONE	SHEET 2 OF 7		

REVISION				
LT#	DESCRIPTION	DWN	DATE	APVD
	SEE SH.1			

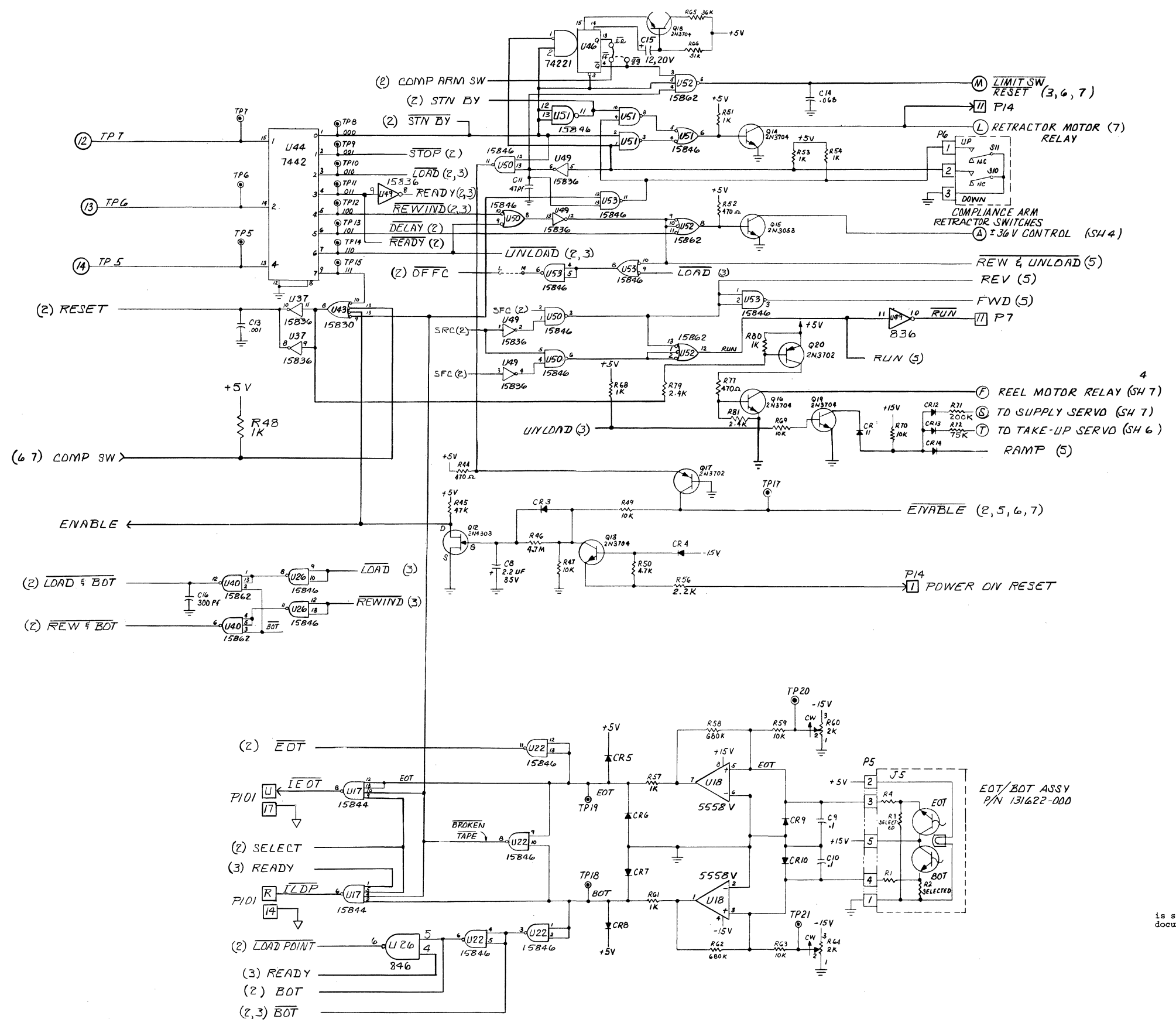

EOT/BOT ASSY
P/N 131622-000

"Use or disclosure of information contained herein is subject to the restriction on the title page of this document."

Cipher San Diego CALIF	
TITLE SCHEM - CONTROL/ SERVO	
SIZE D	CODE IDENT NO. 32274
DRAWING NO. 331580-301	REV 1
SCALE NONE	SHEET 3 OF 7

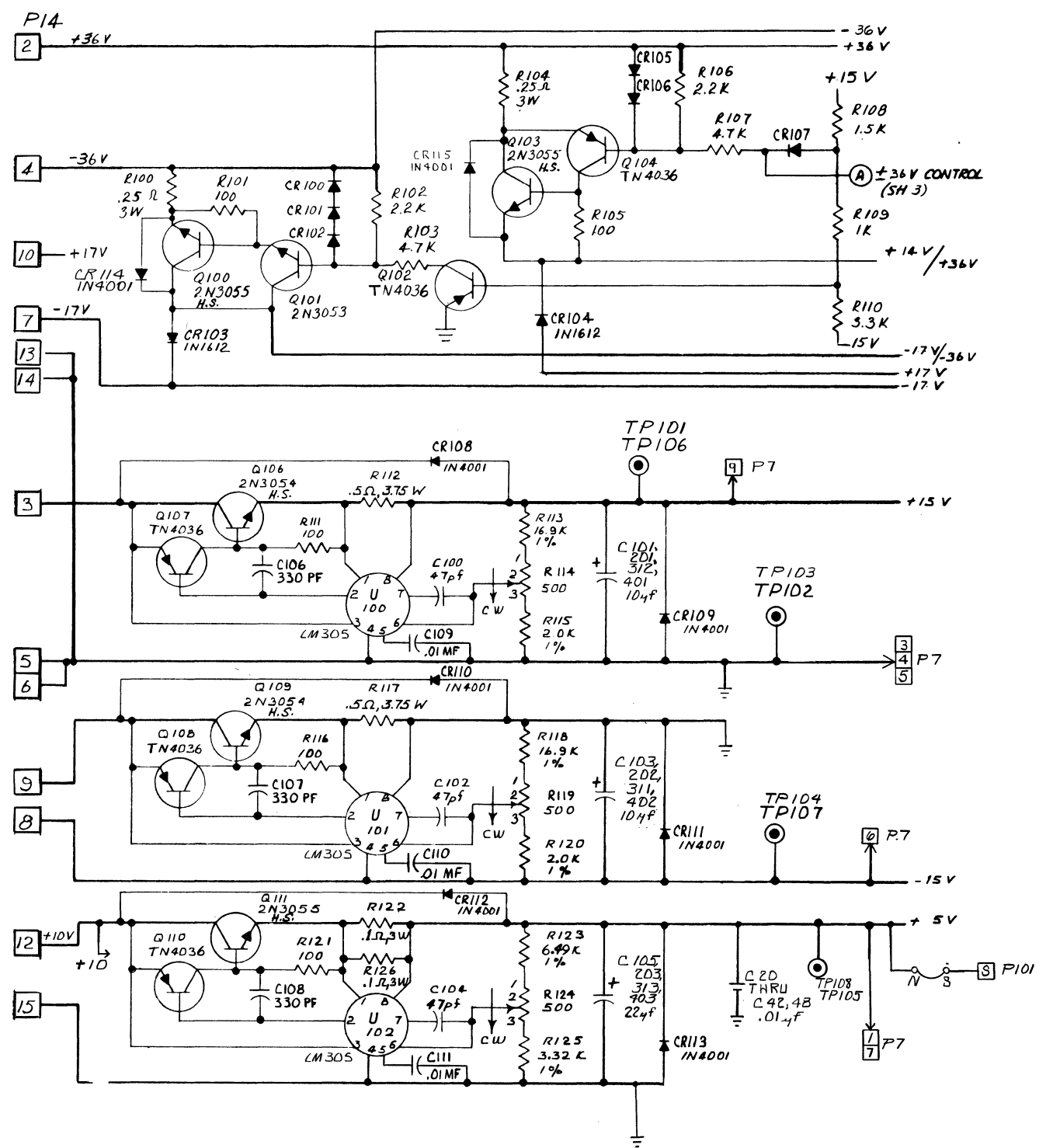

POWER SUPPLY

Cipher			
TITLE		SCALE	
SCHEM - CONTROL/SERVO			
DATE	DRAWING NUMBER	SH	REV
6-25-77	331580-301	4	J

"Use or disclosure of information contained herein is subject to the restriction on the title page of this document."

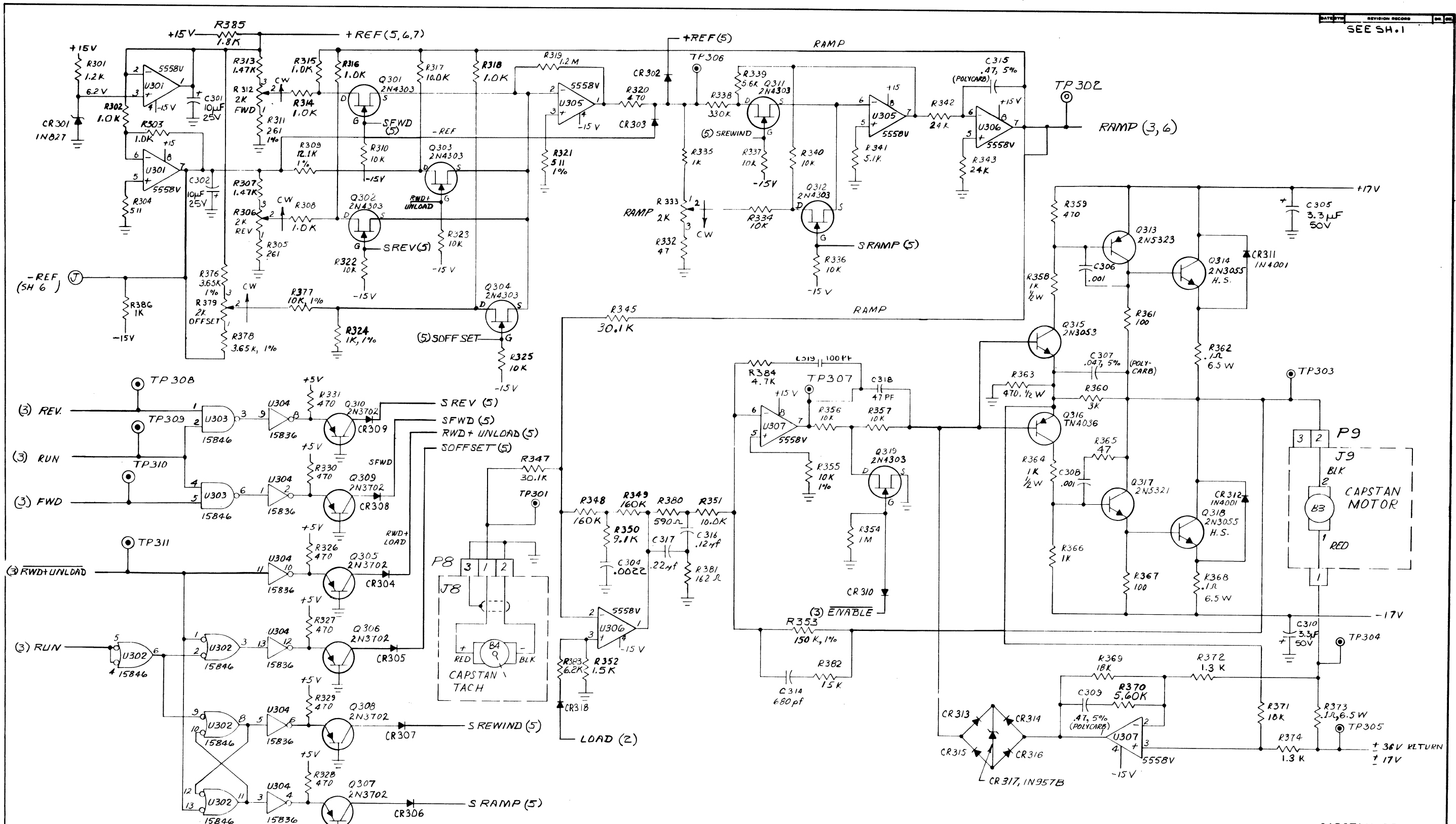

CAPSTAN DRIVER

Cipher	
Scale:	
TITLE: SCHEM- CONTROL/SERVO	
DRAWING NUMBER:	331580-301
SH:	5
REV:	L

"Use or disclosure of information contained herein is subject to the restriction on the title page of this document."

REVISION					
LTR	DESCRIPTION	DWN	DATE	APVD	DAT
	SEE SH. 1				

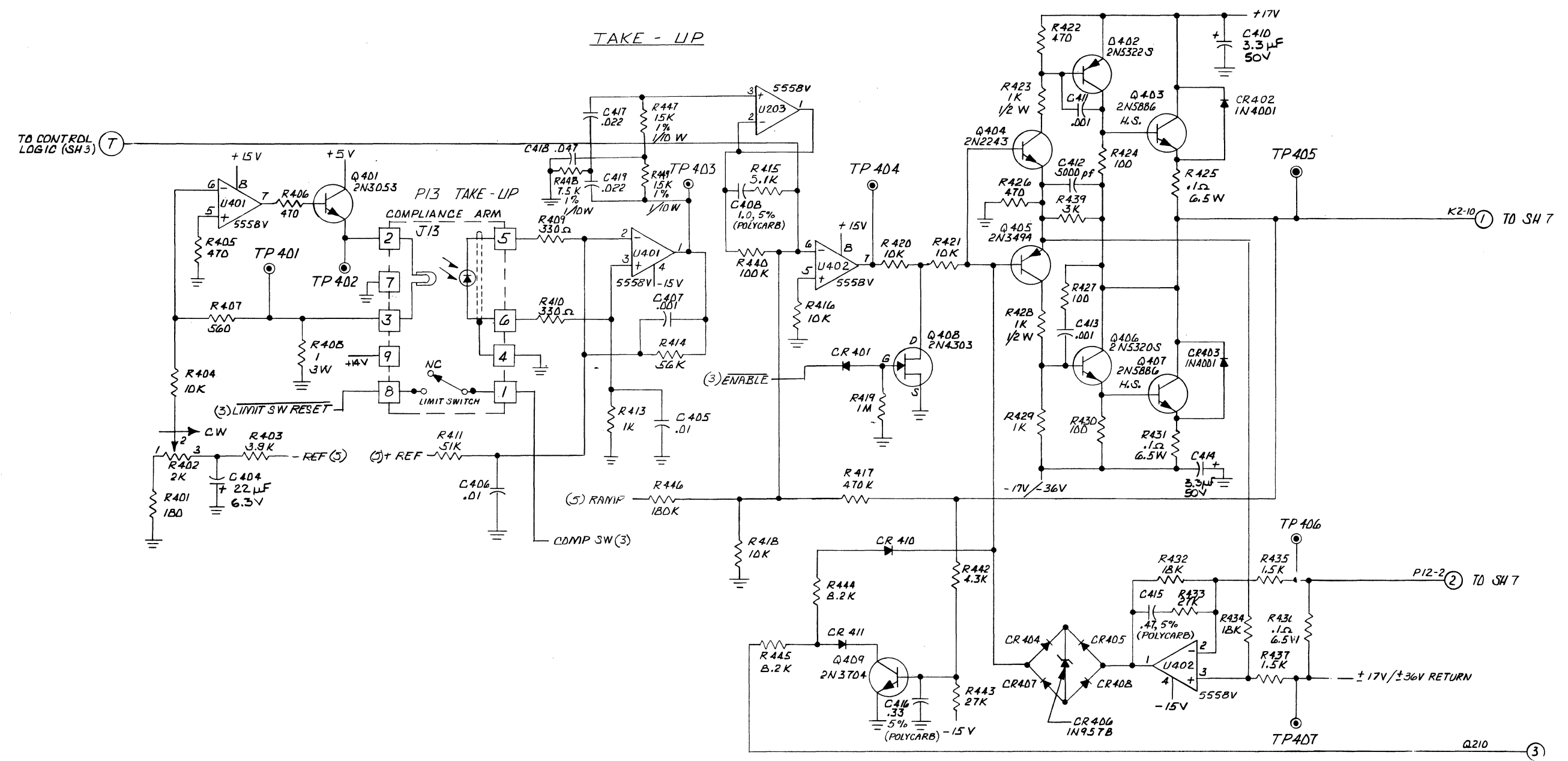

Cipher		SAN DIEGO CALIF	
TITLE SCHEM - CONTROL SERVO			
SIZE D	CODE IDENT NO. 32274	DRAWING NO. 331580-301	REV. 1
SCALE 1/16"	SHEET 6 OF 7		

"Use or disclosure of information contained herein is subject to the restriction on the title page of this document."

FROM SH 6
 (2) P12-2
 (1) K2 10

SUPPLY

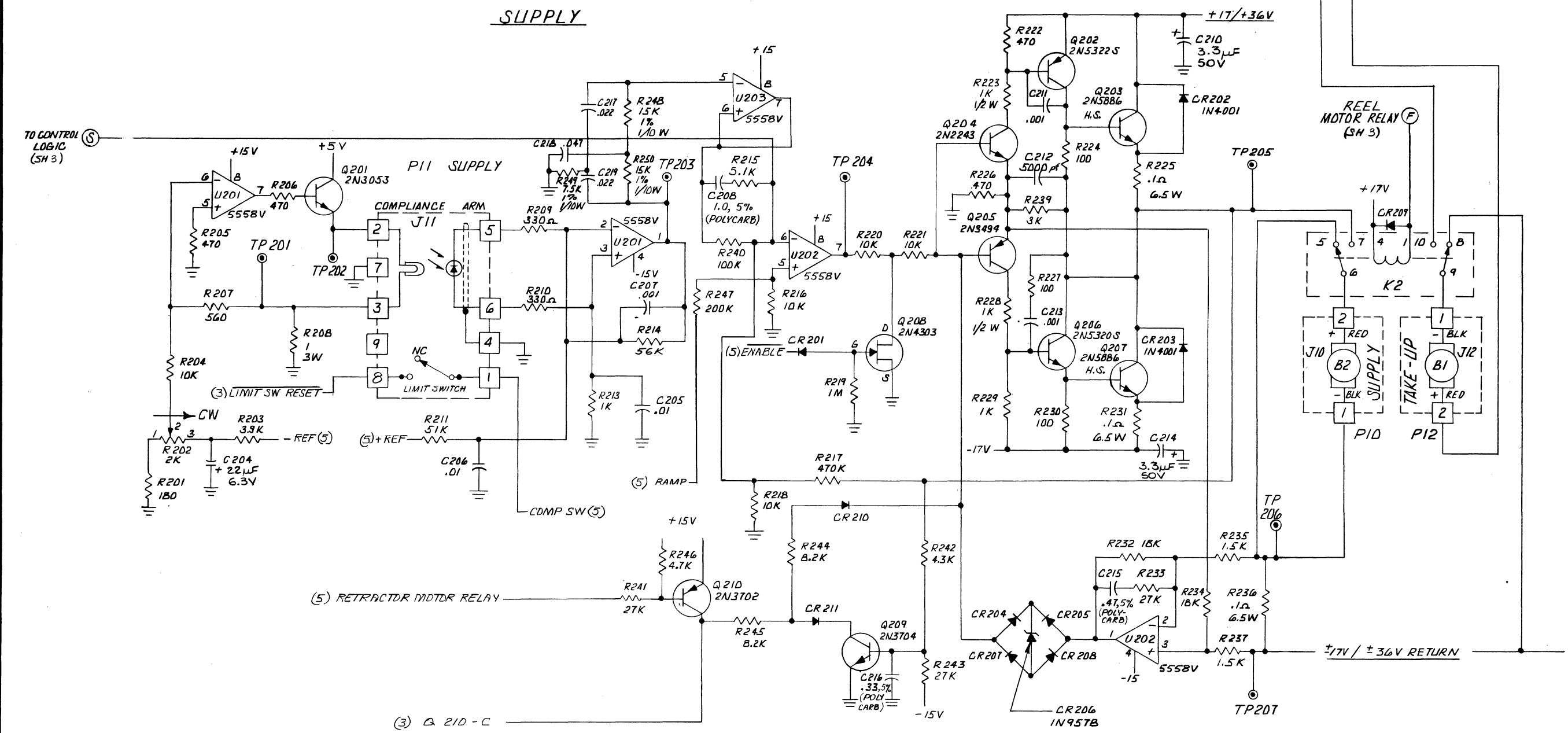

"Use or disclosure of information contained herein is subject to the restriction on the title page of this document."

Cipher SAN DIEGO CALIF	
TITLE SCHEM - CONTROL / SERVO	
SIZE D	CODE IDENT NO. 32274
DRAWING NO. 331580-301	REV J
SCALE NONE	SHEET 7 OF 7

8

7

6

5

4

3

2

1

"All information contained in or disclosed by this document is considered CONFIDENTIAL and PROPRIETARY by Cipher Data Products, Inc. By accepting this material the recipient agrees that this material and the information contained therein is held in confidence and in trust and will not be used, reproduced in whole or in part, nor its contents revealed to others, except to meet the purpose for which it was delivered. It is understood that no right is conveyed to reproduce or have reproduced any item herein disclosed without express permission from Cipher Data Products, Inc."

154040-009
REV A17

REVISION		DWN	DATE	APVD	DATE
LTR	DESCRIPTION				
AE	REDRAW & INCORP ECO 9731	LJS	8-7-81	[Signature]	4-10-81
AF	INCORP ECO 10543	EC	7-24-81	[Signature]	8-19-81
AG	INCORP ECO 11525	FS	11-6-81	[Signature]	11-27-81
AH	INCORP ECO 11901	FS	11-27-81	[Signature]	11-27-81
AJ	INCORP ECO 13977	EC	11-27-81	[Signature]	11-27-81
AK	INCORP ECO 14996	EC	7-13-82	[Signature]	7-13-82
AL	INCORP ECO 15321	EPC	7-28-82	[Signature]	7-28-82
AM	INCORP ECO 15326	EPC	8-4-82	[Signature]	8-4-82

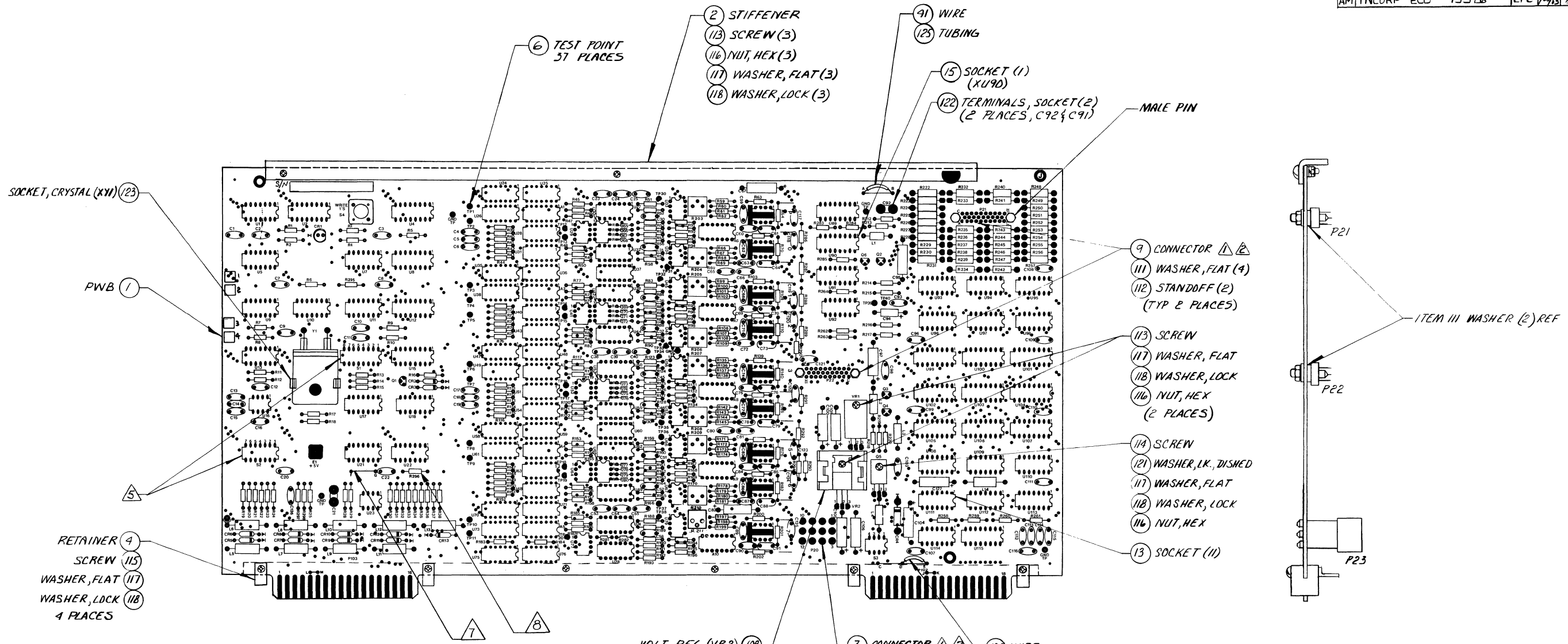

- 8 R296 NOT USED (USED FOR 158010-001 ONLY).
- 7 INSTALL JUMPER F-G.
- 6 DO NOT INTERMIX TERMINALS, ITEM # 8 (205012) AND ALT PART (205012-001) IN ONE CONNECTOR.
- 5 ORIENT SWITCH NUMBERS WITH SILKSCREEN NUMBERS ON PWB (REF S1, S2 & S3)
- 4 FOR SCHEMATIC SEE 354040-300;
- 3 ASSY SHOWN IS FULLY LOADED PWB FOR SPECIFIC CONFIGURATIONS SEE APPROPRIATE PARTS LIST DASH NO. PARTS NOT NEEDED WILL BE OMITTED DURING FAB. OF ASSY.
- 2 INSTALL CONNECTORS ON FAR SIDE OF BOARD. DISCARD NUT AND WASHER FURNISHED WITH CONNECTOR. ASSEMBLE WITH WASHER (ITEM 111) AND STANDOFF (ITEM 112) AS SHOWN.
- 1 MARK EACH CONNECTOR WITH A COLORED PAINT DOT AS FOLLOWS P20- GREEN, P21- RED, P22 - YELLOW.

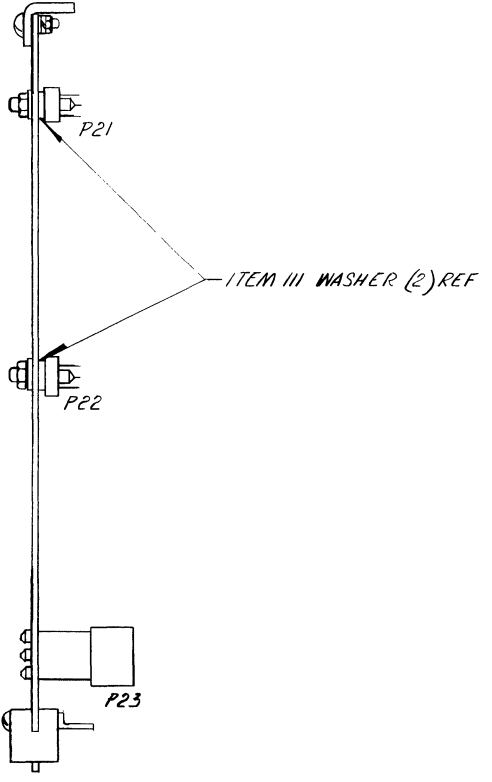

UNLESS OTHERWISE SPECIFIED DIMENSIONS ARE IN INCHES TOLERANCES ARE:		APPROVALS		DATE		SAN DIEGO CALIF Cipher Data Products
DECIMALS	ANGLES	CHK	K. BERLING	7-15-78		
XX ± .01	± .1	MECH	B. BARTON	7-21-78	TITLE PWB ASSY - DATA, DUAL	
XXX ± .01		ELEC	M.D.G.	7-22-78	97K RAW (NO SPEED KIT)	
		MFG	B. SPECHT	7-22-78	SIZE	D
		QC	M. FRACKER	7-28-78	CODE IDENT NO.	32274
		DOC	J. WILLIAMS	7-28-78	DRAWING NO.	154040-009 A
DO NOT SCALE DRAWING		SCALE	1/1		SHEET	1 OF 1

8

7

6

5

4

3

2

1

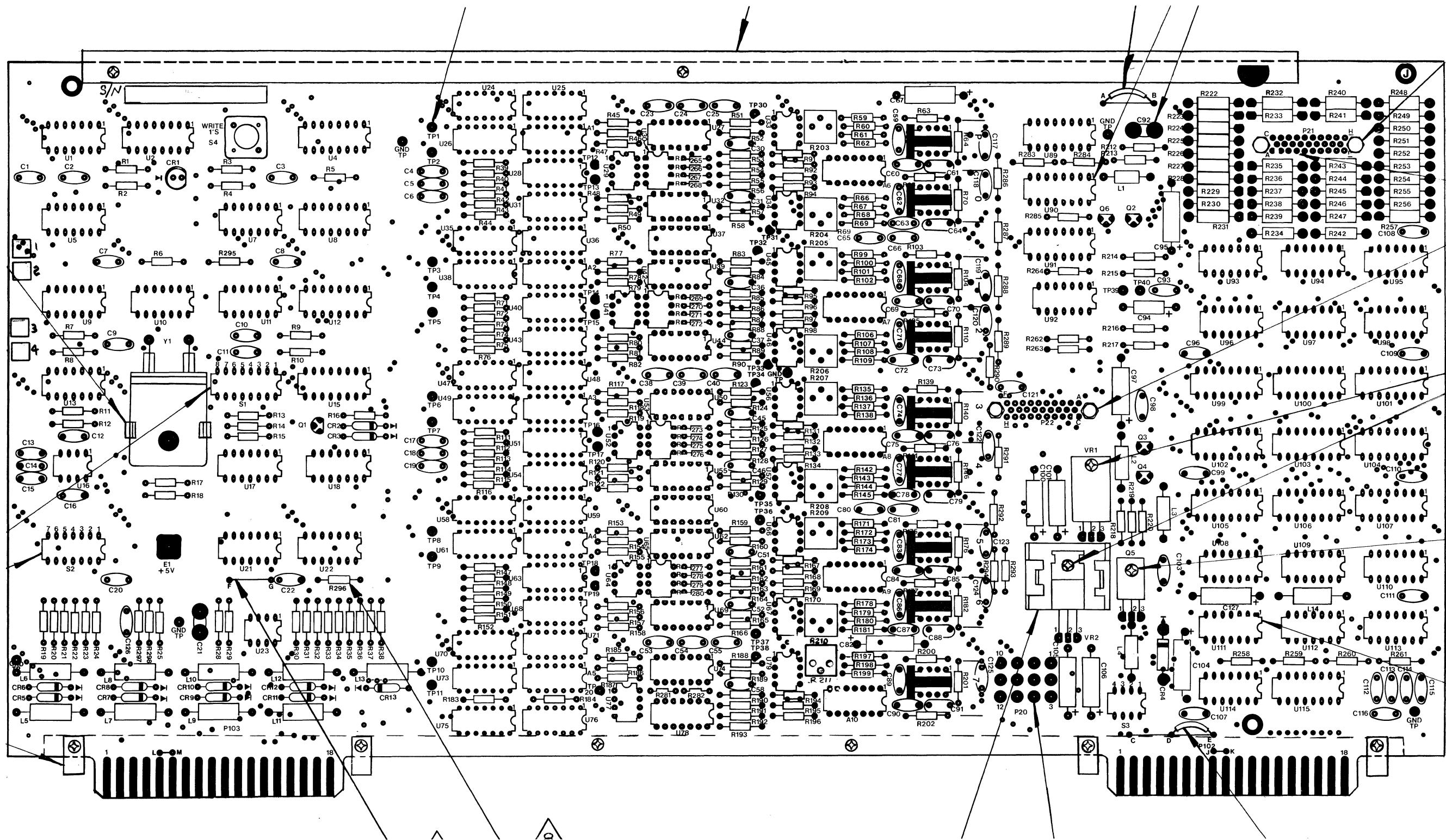

"All information contained in or disclosed by this document is considered CONFIDENTIAL and PROPRIETARY by Cipher Data Products, Inc. By accepting this material the recipient agrees that this material and the information contained therein is held in confidence and in trust and will not be used, reproduced in whole or in part, nor its contents revealed to others, except to meet the purpose for which it was delivered. It is understood that no right is conveyed to reproduce or have reproduced any item herein disclosed without express permission from Cipher Data Products, Inc."

REVISION					
LTR	DESCRIPTION	DWN	DATE	APVD	DATE
A	ENB REL	ZPS	8/17/78	MLC	10/1/79
B	ECO 4206	LVS	10/27/78	ZPS	10-1-79
C	ECO 4301	LVS	10/27/78	ZPS	10-1-79
D	ECO 4385	ZPS	11-21-78	ZPS	11-7-79
E	ECO 4496	ZPS	12-18-78	ZPS	12-7-79
F	ECO 4499	ZPS	12-18-78	ZPS	12-7-79
G	ECO 4622	ZPS	1-21-79	ZPS	1-7-80
H	ECO 5192	SGS	5-16-79	ZPS	5-16-79
J	ECO 5252	VN	8-17-79	ZPS	9/1/79
K	ECO 5371	VN	9-18-79	ZPS	9/1/79
L	ECO 5415	VN	11-19-79	ZPS	9/1/79
M	INCORP ECO 6725	RA	1-11-79	ZPS	11-1-79
N	INCORP ECO 6806	RL	12-1-79	ZPS	12-1-79
P	INCORP ECO 6938	SGS	5-22-80	ZPS	1-23-80
R	INCORP ECO 7492	KMW	5-22-80	ZPS	6-10-80
S	INCORP ECO 7634	CLW	6-30-80	ZPS	6-1-80
T	INCORP ECO 8511	LJ	11-7-80	ZPS	11-7-80
U	INCORP ECO 8872	EA	3-6-81	ZPS	3-1-81
V	INCORP ECO 9738	LJ	3-23-81	ZPS	3-1-81
W	INCORP ECO 11526	EC	1-28-81	ZPS	1-1-81
Y	INCORP ECO 11903	EC	1/21/81	ZPS	1-1-81
Z	INCORP ECO 11940	EC	1/21/81	ZPS	1-1-81
AA	INCORP ECO 11964	UA	1/29/81	ZPS	1-1-81
AB	INCORP ECO 13031	ECN	7/20/81	ZPS	7-1-81
AC	INCORP ECO 14260	EC	7/20/81	ZPS	7-1-81

COMPONENT VALUE TABLE

PWB ASSY	R14	R15
154040-XXX	150K	430K
158010-001	330K	150K

- ① INSTALL JUMPER FOR 154040-009 ONLY.
- ② R296 IS USED ON 158010-001 ONLY.
- ③ FOR COMPONENT VALUE SEE TABLE
- 4. SHEET AND SIGNAL REFERENCE CODE.
 - INDICATES SIGNAL SOURCE SHEET NO.
 - INDICATES SHEET NO. SIGNAL IS GOING TO.
 - INDICATES SHEET NO. SIGNAL IS COMING FROM.
 - "X" TO LEFT OF BUBBLE INDICATES FIRST SHT. THAT SIGNAL APPEARS ON.
 - "X" TO RIGHT OF BUBBLE INDICATES LAST SHT. THAT SIGNAL APPEARS ON.
 - COMPONENTS WITH REF. DES. STARTING WITH "A" ARE MOUNTED ON HEADERS
 - ALL RESISTORS ARE 1/4W, 5% UNLESS OTHERWISE SPECIFIED
 - ALL 3P CAPS ARE INTRINSIC TO PWB.
- NOTES: UNLESS OTHERWISE SPECIFIED

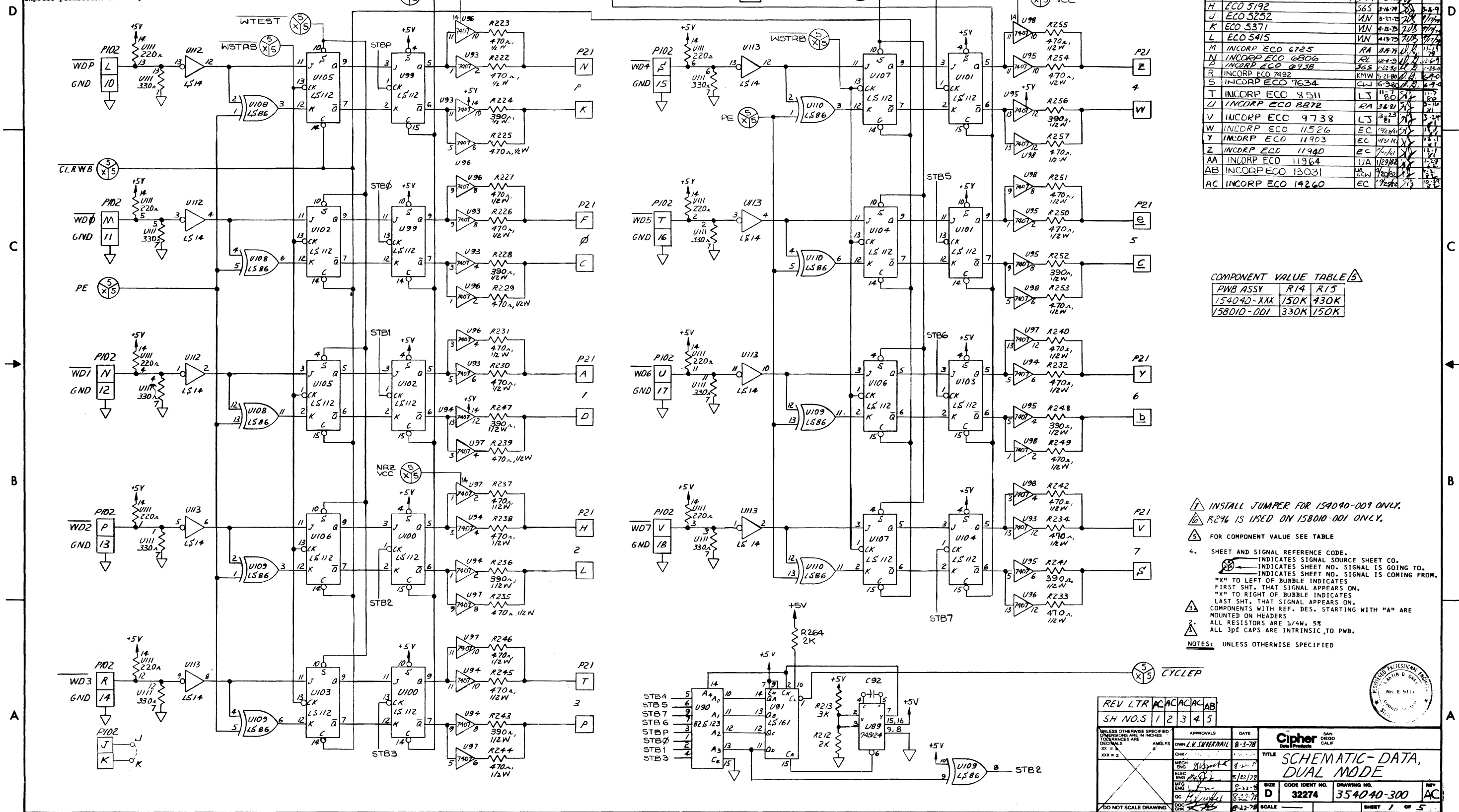

REV LTR	AC	AC	AC	AC	AB
SH NO.S	1	2	3	4	5
APPROVALS: OWN: L.V. SHERMAN 8-3-78 CHK: MECH: ELEC: ENG: MFG: ENS: OC: DOC: CHK:					
DATE: 8/22/78			TITLE: SCHEMATIC-DATA, DUAL MODE		
SIZE: D		CODE IDENT NO.: 32274		DRAWING NO.: 354040-300	
SHEET 1 OF 5					



"Use or disclosure of information contained herein is subject to the restriction on the title page of this document."

REV	DATE	BY	DATE

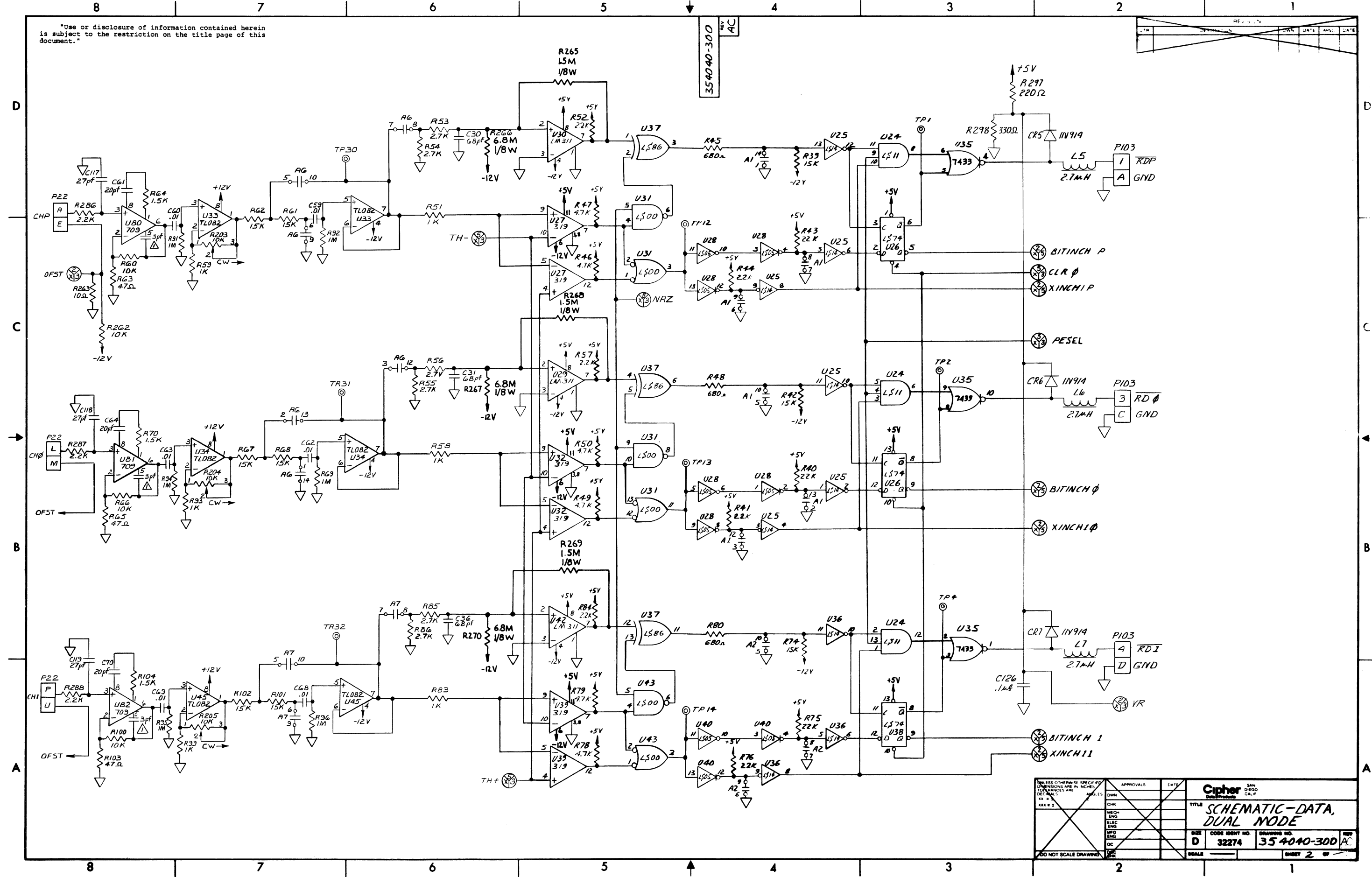

UNLESS OTHERWISE SPECIFIED DIMENSIONS ARE IN INCHES DECIMALS ARE .001 ANGLES ARE 90° UNLESS SHOWN OTHERWISE	APPROVALS	DATE	Cipher SAN DIEGO CALIF TITLE SCHEMATIC-DATA, DUAL MODE SIZE D CODE IDENT. NO. 32274 DRAWING NO. 354040-300 AC SCALE --- SHEET 2
	CHK		
	MECH ENG		
	ELEC ENG		
ADD NOT SCALE DRAWING			

"Use or disclosure of information contained herein is subject to the restriction on the title page of this document."

REVISION				
LTR	DESCRIPTION	DWN	DATE	APPV

354040-300
REV AC

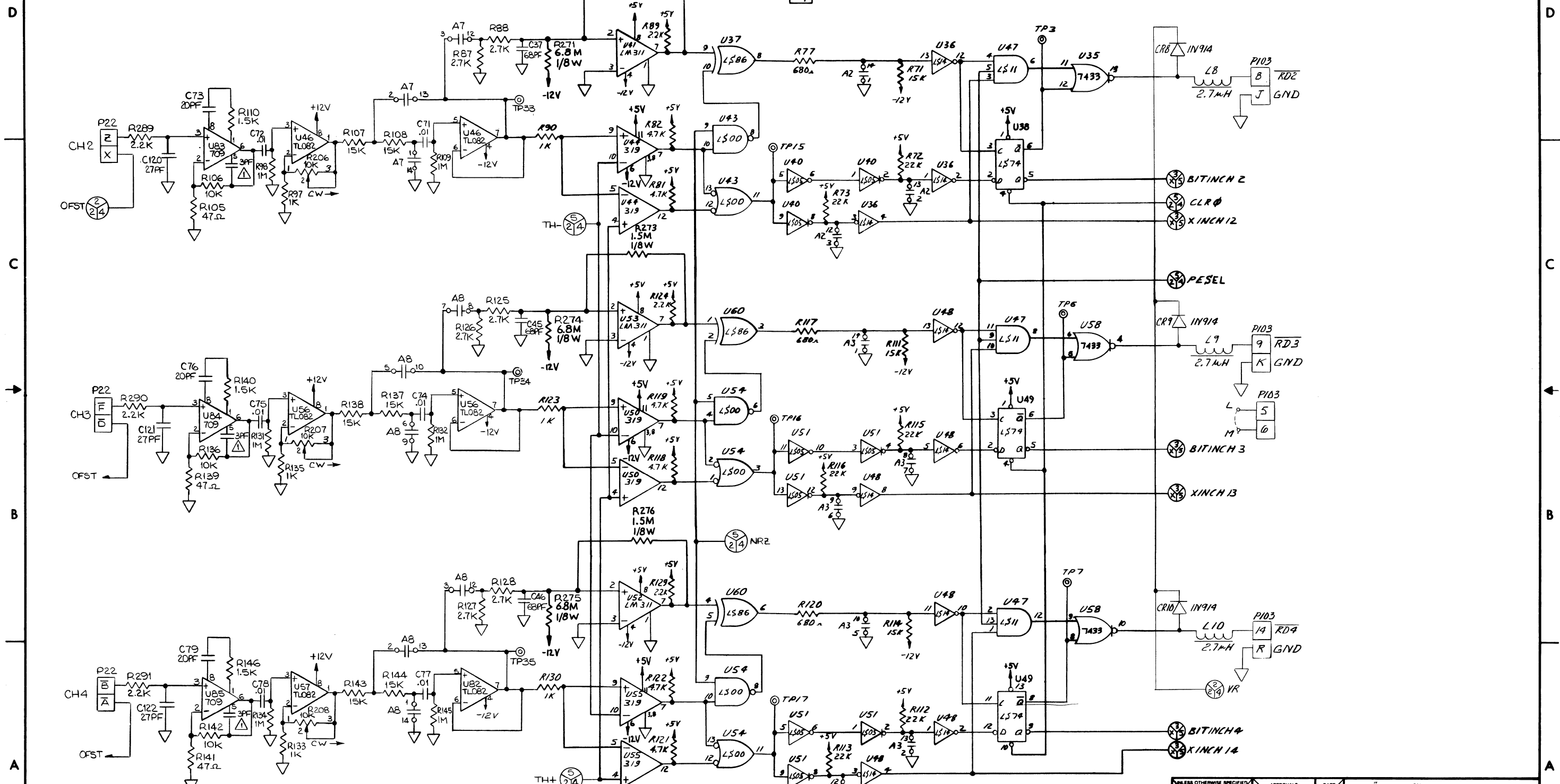

UNLESS OTHERWISE SPECIFIED, DIMENSIONS ARE IN INCHES. DECIMALS ARE XX X.XX X.XX X.X	APPROVALS	DATE	Cipher SAN DIEGO CALIF TITLE SCHMATIC-DATA, DUAL MODE SIZE D CODE IDENT NO. 32274 DRAWING NO. 354040-300 REV AC SCALE _____ SHEET 3 OF 3

"Use or disclosure of information contained herein is subject to the restriction on the title page of this document."

REVISION				
LTN	DESCRIPTION	DNW	DATE	APVD

354040-300
REV AC

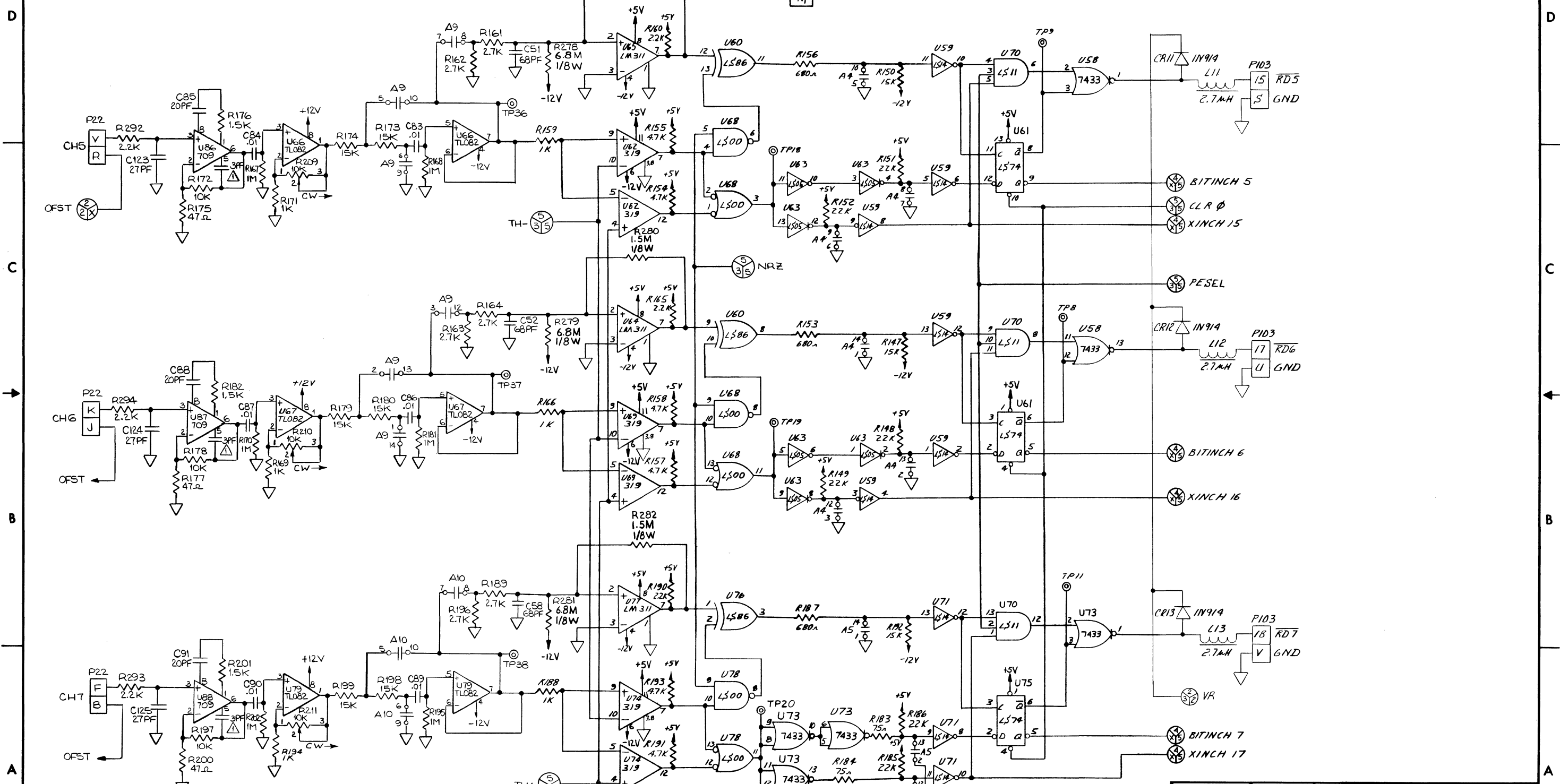

UNLESS OTHERWISE SPECIFIED DIMENSIONS ARE IN INCHES/ TOLERANCES ARE DECIMALS XX = . XXX = .	APPROVALS	DATE	SAN DIEGO CALIF. TITLE SCHEMATIC-DATA DUAL MODE SIZE D CODE IDENT NO. 32274 DRAWING NO. 354040-300 AC REV 1 SHEET 4 OF
	CHK		
	MCH		
	ELEC		
DO NOT SCALE DRAWING	SCALE		

REVISION		DATE	APVD	DATE

"Use or disclosure of information contained herein is subject to the restriction on the title page of this document."

354040-300
REV AB

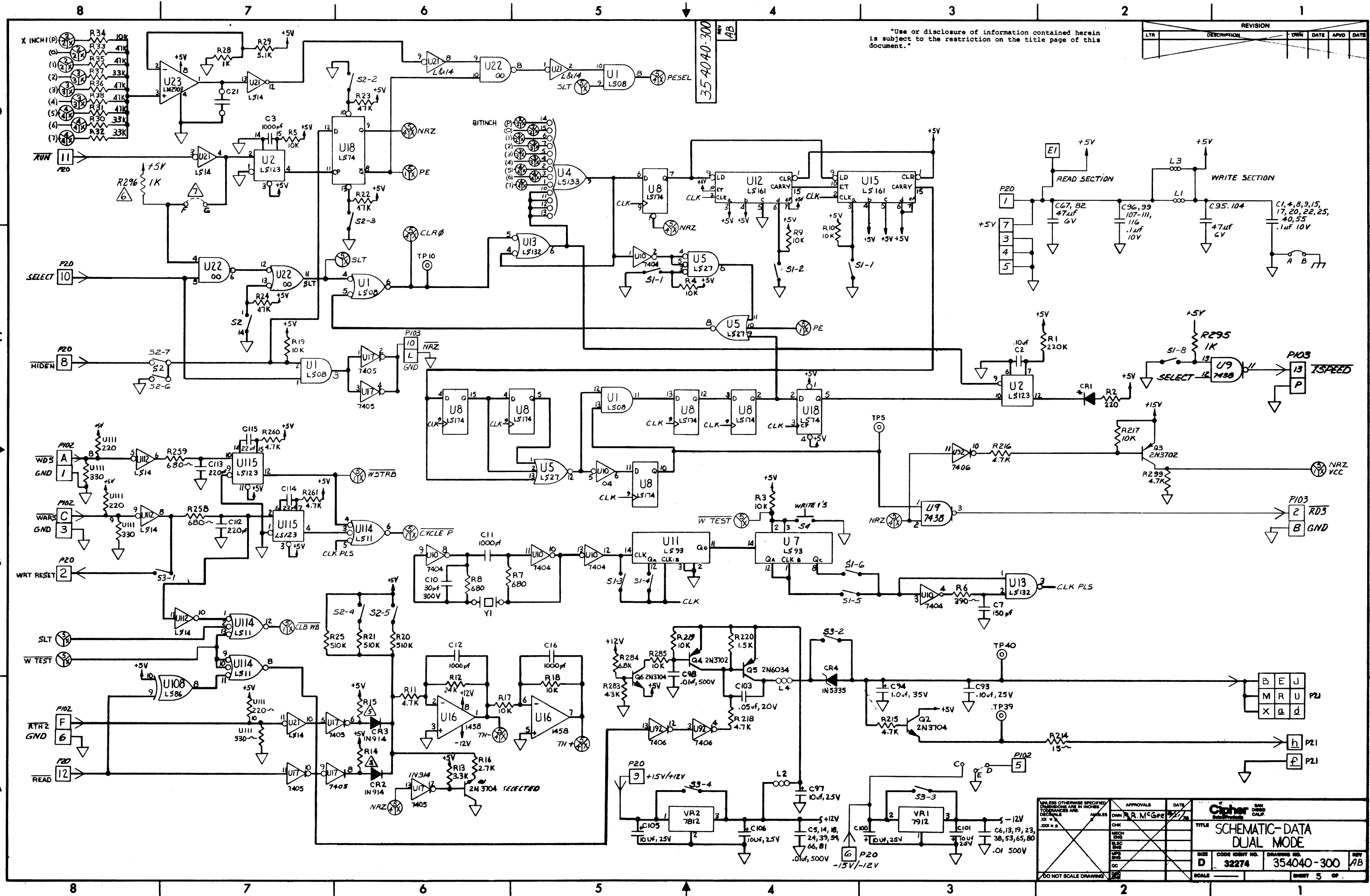

UNLESS OTHERWISE SPECIFIED DIMENSIONS ARE IN INCHES TOLERANCES ARE: DECIMALS .01 ± .001 ± .002	APPROVALS CHK MECH ENG ELC ENG LPS ENG OC	DATE R. MCGP / /	
TITLE SCHEMATIC-DATA DUAL MODE		SIZE D	DRAWING NO. 354040-300
DO NOT SCALE DRAWING		SCALE	SHEET 5 OF 5

QTY GIVEN IS NUMBER OF PARTS OR LENGTH OF MATERIAL IN FEET

ITEM	CIPHER PART #	QTY	DESCRIPTION 1 DESCRIPTION 2	MFG-NAME MFG-PART#	REF-DES	ST-DATE	END-DATE
1	731048-700	1	TOP PLATE-MTT 100,DIECAST MACHINING	CIPHER DATA PROD			
2	131008-000	1	COMP ARM RETRACTOR ASSY	CIPHER DATA PROD			
3	131004-001	2	COMPLIANCE ARM ASSY	CIPHER DATA PROD			
4	131010-001	2	REEL HUB ASSY	CIPHER DATA PROD			
5	131001-001	1	HDWR PKG,RACK MTC	CIPHER DATA PROD			
6	131024-001	1	MOUNTING BRACKET ASSY	CIPHER DATA PROD			
7	131024-002	1	MOUNTING BRACKET ASSY	CIPHER DATA PROD			
8	154022-100	1	SHIPPING CARTON	CIPHER DATA PROD			
9	131014-000	2	REEL MOTOR ASSY	CIPHER DATA PROD			
10	131015-001	1	CAPSTAN MOTOR ASSY	CIPHER DATA PROD			
11	131028-000	1	PUSH BAR ASSY,ARM RETRACT	CIPHER DATA PROD			
12	131075-101	2	TAPE GUIDE ASSY	CIPHER DATA PROD			
13	131505-000	1	CABLE ASSY	CIPHER DATA PROD			
14	131506-000	1	CABLE ASSY-R/W BOARD TO SERVO BOARD J7-J20	CIPHER DATA PROD			
15	131507-002	1	TRANSFORMER ASSY-115VOLT	CIPHER DATA PROD			
16	131006-000	1	FILE PROTECT SW ASSY	CIPHER DATA PROD			
17	131016-400	1	PIN ASSY-FILE PROTECT	CIPHER DATA PROD			
18	131580-001	1	PWB ASSY-CONTROL/SERVO	CIPHER DATA PROD			

QTY GIVEN IS NUMBER OF PARTS OR LENGTH OF MATERIAL IN FEET

ITEM	CIPHER PART #	QTY	DESCRIPTION 1 DESCRIPTION 2	MFG-NAME MFG-PART#	REF-DES	ST-DATE	END-DATE
19	131080-101	1	POWER SUPPLY ASSY	CIPHER DATA PROD			
20	131622-000	1	EOT/BOT ASSY	CIPHER DATA PROD			
21	131003-800	1	REFLECTOR ASSY	CIPHER DATA PROD			
22	131047-001	1	TAPE SCRAPER ASSY	CIPHER DATA PROD			
23	131910-700	1	STANDOFF ASSY, HINGED	CIPHER DATA PROD			
24	131012-900	2	DOOR STAY ASSY	CIPHER DATA PROD			
25							
26	731042-000	1	WARNING LABEL-CAPSTAN	CIPHER DATA PROD			
27	731039-501	1	FACADE	CIPHER DATA PROD			
28	731051-300	1	COVER-HEAD,RIGHT	CIPHER DATA PROD			
29	731008-300	1	CONN ROD-ARM RETRACT	CIPHER DATA PROD			
30	731008-400	1	CRANK PIN-ARM RETRACT	CIPHER DATA PROD			
31	731051-200	1	COVER-HEAD,LEFT	CIPHER DATA PROD			
32							
33	731003-600	1	CATCH PIN-DUST DOOR	CIPHER DATA PROD			
34	754022-801	1	SHIPPING FRAME-100X/900X	CIPHER DATA PROD			
35	731037-100	2	BUMPER PAD	CIPHER DATA PROD			
36	731005-900	1	CAP CAPSTAN SLEEVE	CIPHER DATA PROD			
37	731023-901	1	GUIDE-FILE PROTECT PIN	CIPHER DATA PROD			

QTY GIVEN IS NUMBER OF PARTS OR LENGTH OF MATERIAL IN FEET

ITEM	CIPHER PART #	QTY	DESCRIPTION 1 DESCRIPTION 2	MFG-NAME MFG-PART#	REF-DES	ST-DATE	END-DATE
38	731510-703	1	STANDOFF	CIPHER DATA PROD			
39	731510-704	1	STANDOFF	CIPHER DATA PROD			
40	752003-701	1	PAWL - LATCH	CIPHER DATA PROD			
41	760104-520	3	SHIM-STAINLESS STEEL	CIPHER DATA PROD			
ALT	731586-401		SHIM-CLEAR MYLAR	CIPHER DATA PROD			
42	760104-521	3	SHIM-STAINLESS STEEL	CIPHER DATA PROD			
ALT	731586-402		SHIM-CLEAR MYLAR	CIPHER DATA PROD			
43	760104-522	3	SHIM-STAINLESS STEEL	CIPHER DATA PROD			
ALT	731586-403		SHIM-CLEAR MYLAR	CIPHER DATA PROD			
44	760104-523	3	SHIM-STAINLESS STEEL	CIPHER DATA PROD			
ALT	731586-404		SHIM-CLEAR MYLAR	CIPHER DATA PROD			
45	960522-001	1	CAPSTAN-LOW INERTIA MACHINING SPECS	CIPHER DATA PROD		01-01-84	L#121
46	731586-101	1	SHAFT-LATCH,100X DIECAST	CIPHER DATA PROD			
47	716017-001	3	ROLLER TAPE GUIDE (SHORT)	CIPHER DATA PROD			
48	799003-200	2	ROLLER TAPE GUIDE	CIPHER DATA PROD			
49	760104-524	3	SHIM-STAINLESS STEEL	CIPHER DATA PROD			
ALT	731586-405		SHIM-CLEAR MYLAR	CIPHER DATA PROD			

QTY GIVEN IS NUMBER OF PARTS OR LENGTH OF MATERIAL IN FEET

ITEM	CIPHER PART #	QTY	DESCRIPTION 1 DESCRIPTION 2	MFG-NAME MFG-PART#	REF-DES	ST-DATE	END-DATE
50	760104-525	3	SHIM-STAINLESS STEEL	CIPHER DATA PROD			
ALT	731586-406		SHIM-CLEAR MYLAR	CIPHER DATA PROD			
51	731042-700	1	LABEL, FUSE REPLACEMENT	CIPHER DATA PROD			
52	731911-002	AR	SHIM-TAPE GUIDE (.010)	CIPHER DATA PROD			
53	731911-003	AR	SHIM-TAPE GUIDE (.020)	CIPHER DATA PROD			
54	731911-001	AR	SHIM-TAPE GUIDE (.005)	CIPHER DATA PROD			
55	731911-106	2	SHIM .020THICK 1/4IN ID	CIPHER DATA PROD			
56	210555-036	1	TERM,SLIP-ON.187 TAB,REEL	HOLLINGSWORTH TERM. CO. S05304F-T1			
ALT	210555-034		TERMINAL-SLIP-ON,.187 TAB	HOLLINGSWORTH TERM. CO. S05304F			
57	210188	4	PLUG,BANANA	SMITH,HERMAN H. 100			
58	210223	1	PIN,GROOV 3/32X3/4	GROOV-PIN GP4-093X0750-12			
59	210837	1	RUBBER BUMPER	MINNESOTA MINING SJ-5112			
60	210229-523	8	TY-RAP-1/16 TO 5/8	ICO RALLY WRN 3 1/2			
61	210199-001	1	RING,RETAINING-CRESCENT	WALDES TRUARC 5103-25-H			
62	210201	1	REEL 10 1/2"	EDP 5198CS			
63	210229-400	1	CLAMP,CABLE-5/16	HEYMAN MANUFACTURING CO. 3325			
64	210003-001	1	SPRING,COMPRESSION	LEE SPRING CO. LC-032E-9MW			
65	210229-200	1	CLAMP,CABLE-3/16	HEYMAN MANUFACTURING CO. 3303			

QTY GIVEN IS NUMBER OF PARTS OR LENGTH OF MATERIAL IN FEET

ITEM	CIPHER PART #	QTY	DESCRIPTION 1 DESCRIPTION 2	MFG-NAME MFG-PART#	REF-DES	ST-DATE	END-DATE
66	210229-500	2	CLAMP,CABLE-7/16	HEYMAN MANUFACTURING CO. 3327			
67	209990-304	AR	ADHESIVE-PLASTIC/VINYL BONDER	LOCTITE 41450			
68	210444	AR	LUBRIPLATE	G.C. ELECTRONICS 23-2S			
69	209990-072	AR	ADHESIVE-LOCTITE *	LOCTITE 222			
70	211151-225	1	FUSE,3AG,NORM-BLO,6A,250V	LITTLEFUSE 312006			
71	211151-223	1	FUSE,3AG,NORM-BLO,4A,250V	LITTLEFUSE 312004			
72	207403-011	8	WASHER,SPLIT LOCK #4	ANY ACCEPTABLE SOURCE WASHER #4 CAD.			
73	207602-011	15	WASHER,SPLIT LOCK #6	ANY ACCEPTABLE SOURCE WASHER #6 CAD.			
74	207102-011	8	WASHER,SPLIT LOCK #10	ANY ACCEPTABLE SOURCE WASHER #10 CAD.			
75	207402-021	7	WASHER,FLAT #4	ANY ACCEPTABLE SOURCE			
76	207605-021	8	WASHER,FLAT #6	ANY ACCEPTABLE SOURCE WASHER #6 CAD.			
77	207104-021	10	WASHER, FLAT,#10	ANY ACCEPTABLE SOURCE WASHER #10 CAD.			
78	207608-021	7	WASHER,FLAT,SMALL OD #6	ANY ACCEPTABLE SOURCE WASHER #6 CAD.			
79	207408-021	1	WASHER,FLAT,SMALL OD #4	ANY ACCEPTABLE SOURCE			
80	207604-081	1	NUT-HEX RADIO PATTERN 6-32	ANY ACCEPTABLE SOURCE NUT #6 CAD.			
81	207406-081	1	NUT,HEX,RADIO PAT. #4 4-40	ANY ACCEPTABLE SOURCE NUT #4 CAD.			
82	213271-404	7	SCREW-PAN HD,PHIL 4-40 X 1/4	ANY ACCEPTABLE SOURCE			
83	213271-406	4	SCREW-PAN HD PHIL 4-40 X 3/8 CAD BLK ZINC	ANY ACCEPTABLE SOURCE			

QTY GIVEN IS NUMBER OF PARTS OR LENGTH OF MATERIAL IN FEET

ITEM	CIPHER PART #	QTY	DESCRIPTION 1 DESCRIPTION 2	MFG-NAME MFG-PART#	REF-DES	ST-DATE	END-DATE
84	213091-406	6	SCREW-SKT HD CAP 4-40 X 3/8,CAD,BLK,ZINC	ANY ACCEPTABLE SOURCE			
85	213091-408	2	SCREW-SKT HD CAP 4-40 X 1/2,CAD,BLK,ZINC	ANY ACCEPTABLE SOURCE			
86	213091-410	8	SCREW-SKT HD CAP 4-40 X 5/8,CAD,BLK,ZINC	ANY ACCEPTABLE SOURCE			
87	213091-422	2	SCREW-SKT HD CAP 4-40 X 1 3/8,CAD,BLK,ZINC	ANY ACCEPTABLE SOURCE			
88							
89	213271-604	1	SCREW-PAN HEAD PHIL 6-32 X 1/4,CAD,BLK,ZINC	ANY ACCEPTABLE SOURCE			
90	213271-609	1	SCREW-PAN HEAD,PHIL 6-32 X 9/16,CAD,BLK,ZINC	ANY ACCEPTABLE SOURCE			
91							
92	213091-606	11	SCREW-SKT HD CAP, 6-32 X 3/8,CAD,BLK,ZINC	ANY ACCEPTABLE SOURCE			
93	213091-608	6	SCREW-SKT HD CAP 6-32 X 1/2,CAD,BLK,ZINC	ANY ACCEPTABLE SOURCE			
94	213091-610	6	SCREW-SKT HD CAP 6-32 X 5/8,CAD,BLK,ZINC	ANY ACCEPTABLE SOURCE			
95	213202-618	1	SCREW-FL HD SKT,82, 6-32 X 1-1/8,BLK ONLY	ANY ACCEPTABLE SOURCE			
96	213351-608	2	SCREW-SOC SET CUP PT, 6-32 X 1/2,CAD,BLK,ZINC	ANY ACCEPTABLE SOURCE			
97	213092-110	6	SCREW-SKT HD CAP, 10-32 X 5/8 BLK	ANY ACCEPTABLE SOURCE			
98	213091-108	4	SCREW-SKT HD CAP 10-32 X 1/2,CAD,BLK,ZINC	ANY ACCEPTABLE SOURCE			
99	213091-122	3	SCREW-SKT HD CAP, 10-32 X 1-3/8,CAD,BL,ZINC	00000			
100	207000-064	1	NUT-HEX,LIGHT,THIN	ESNA 79NTE-048			
101	213091-116	8	SCREW SOC HD,CAP 10-32 X 1,CAD,BLK,ZINC	ANY ACCEPTABLE SOURCE			
102	211076	4	SCREW,SHOULDER	ANATOM ELECTRONIC HDW 7456-SS-0832			

QTY GIVEN IS NUMBER OF PARTS OR LENGTH OF MATERIAL IN FEET

ITEM	CIPHER PART #	QTY	DESCRIPTION 1 DESCRIPTION 2	MFG-NAME MFG-PART#	REF-DES	ST-DATE	END-DATE
103	210028-200	2	WASHER-FLAT,NYLON	AMATOM ELECTRONIC HDW 2257-M194			
104	211036	1	SWITCH "REVERSE"	MOLEX,INC. 1820RL122332428516604 REV			
105	211037	1	SWITCH "FORWARD"	MOLEX,INC. 1820RL122332428516604 FWD			
106	211038	1	SWITCH "HI DEN"	MOLEX,INC. 1820RL122332428516604 HDN			
107	211039	1	SWITCH "LOAD"	MOLEX,INC. 1820RL125332428516604 LD			
108	211040	1	SWITCH "ON LINE"	MOLEX,INC. 1820RL125332428516604 ONL			
109	211042	1	SWITCH "WRT EN"	MOLEX,INC. 1820RL125332428516604 WRT			
110	211041	1	SWITCH "REWIND"	MOLEX,INC. 1820RL125332428516604 RWD			
111	211051-501	1	SWITCH-LIGHTED,PUSH BTN	MOLEX,INC. 01-56-1032			
112	131502-000	1	CABLE ASSY-SWITCHES	CIPHER DATA PROD			
113	131503-000	1	CABLE ASSY-SWITCH LAMPS	CIPHER DATA PROD			
114	131504-000	1	CABLE ASSY-POWER SWITCH	CIPHER DATA PROD			
115	- 119 ARE BLANK.						
120	*****						
121	726010-100	1	CAPSTAN LOW INERTIA	CIPHER DATA PROD		L*45	12-31-83

QTY GIVEN IS NUMBER OF PARTS OR LENGTH OF MATERIAL IN FEET

ITEM	CIPHER PART #	QTY	DESCRIPTION 1 DESCRIPTION 2	MFG-NAME MFG-PART#	REF-DES	ST-DATE	END-DATE
1	731048-700	1	TOP PLATE-MTT 100,DIECAST MACHINING	CIPHER DATA PROD			
2	131008-000	1	COMP ARM RETRACTOR ASSY	CIPHER DATA PROD			
3	131004-001	2	COMPLIANCE ARM ASSY	CIPHER DATA PROD			
4	131010-001	2	REEL HUB ASSY	CIPHER DATA PROD			
5	131001-001	1	HDWR PKG,RACK MTC	CIPHER DATA PROD			
6	131024-001	1	MOUNTING BRACKET ASSY	CIPHER DATA PROD			
7	131024-002	1	MOUNTING BRACKET ASSY	CIPHER DATA PROD			
8	154022-100	1	SHIPPING CARTON	CIPHER DATA PROD			
9	131014-000	2	REEL MOTOR ASSY	CIPHER DATA PROD			
10	131015-001	1	CAPSTAN MOTOR ASSY	CIPHER DATA PROD			
11	131028-000	1	PUSH BAR ASSY,ARM RETRACT	CIPHER DATA PROD			
12	131075-101	2	TAPE GUIDE ASSY	CIPHER DATA PROD			
13	131505-000	1	CABLE ASSY	CIPHER DATA PROD			
14	131506-000	1	CABLE ASSY-R/W BOARD TO SERVO BOARD J7-J20	CIPHER DATA PROD			
15	131507-002	1	TRANSFORMER ASSY-115VOLT	CIPHER DATA PROD			
16	131006-000	1	FILE PROTECT SW ASSY	CIPHER DATA PROD			
17	131016-400	1	PIN ASSY-FILE PROTECT	CIPHER DATA PROD			
18	131580-001	1	PWB ASSY-CONTROL/SERVO	CIPHER DATA PROD			

QTY GIVEN IS NUMBER OF PARTS OR LENGTH OF MATERIAL IN FEET

ITEM	CIPHER PART #	QTY	DESCRIPTION 1 DESCRIPTION 2	MFG-NAME MFG-PART#	REF-DES	ST-DATE	END-DATE
19	131080-101	1	POWER SUPPLY ASSY	CIPHER DATA .PROD			
20	131622-000	1	EOT/BOT ASSY	CIPHER DATA PROD			
21	131003-800	1	REFLECTOR ASSY	CIPHER DATA PROD			
22	131047-001	1	TAPE SCRAPER ASSY	CIPHER DATA PROD			
23	131910-700	1	STANDOFF ASSY, HINGED	CIPHER DATA PROD			
24	131012-900	2	DOOR STAY ASSY	CIPHER DATA PROD			
25							
26	731042-000	1	WARNING LABEL-CAPSTAN	CIPHER DATA PROD			
27	731039-501	1	FACADE	CIPHER DATA PROD			
28	731051-300	1	COVER-HEAD,RIGHT	CIPHER DATA PROD			
29	731008-300	1	CONN ROD-ARM RETRACT	CIPHER DATA PROD			
30	731008-400	1	CRANK PIN-ARM RETRACT	CIPHER DATA PROD			
31	731051-200	1	COVER-HEAD,LEFT	CIPHER DATA PROD			
32							
33	731003-600	1	CATCH PIN-DUST DOOR	CIPHER DATA PROD			
34	754022-801	1	SHIPPING FRAME-100X/900X	CIPHER DATA PROD			
35	731037-100	2	BUMPER PAD	CIPHER DATA PROD			
36	731005-900	1	CAP CAPSTAN SLEEVE	CIPHER DATA PROD			
37	731023-901	1	GUIDE-FILE PROTECT PIN	CIPHER DATA PROD			

QTY GIVEN IS NUMBER OF PARTS OR LENGTH OF MATERIAL IN FEET

ITEM	CIPHER PART #	QTY	DESCRIPTION 1 DESCRIPTION 2	MFG-NAME MFG-PART#	REF-DES	ST-DATE	END-DATE
38	731510-703	1	STANDOFF	CIPHER DATA PROD			
39	731510-704	1	STANDOFF	CIPHER DATA PROD			
40	752003-701	1	PAWL - LATCH	CIPHER DATA PROD			
41	760104-520	3	SHIM-STAINLESS STEEL	CIPHER DATA PROD			
ALT	731586-401		SHIM-CLEAR NYLAR	CIPHER DATA PROD			
42	760104-521	3	SHIM-STAINLESS STEEL	CIPHER DATA PROD			
ALT	731586-402		SHIM-CLEAR NYLAR	CIPHER DATA PROD			
43	760104-522	3	SHIM-STAINLESS STEEL	CIPHER DATA PROD			
ALT	731586-403		SHIM-CLEAR NYLAR	CIPHER DATA PROD			
44	760104-523	3	SHIM-STAINLESS STEEL	CIPHER DATA PROD			
ALT	731586-404		SHIM-CLEAR NYLAR	CIPHER DATA PROD			
45	960522-001	1	CAPSTAN-LOW INERTIA MACHINING SPECS	CIPHER DATA PROD		01-01-84	L#121
46	731586-101	1	SHAFT-LATCH,100X DIECAST	CIPHER DATA PROD			
47	716017-001	3	ROLLER TAPE GUIDE (SHORT)	CIPHER DATA PROD			
48	799003-200	2	ROLLER TAPE GUIDE	CIPHER DATA PROD			
49	760104-524	3	SHIM-STAINLESS STEEL	CIPHER DATA PROD			
ALT	731586-405		SHIM-CLEAR NYLAR	CIPHER DATA PROD			

QTY GIVEN IS NUMBER OF PARTS OR LENGTH OF MATERIAL IN FEET

ITEM	CIPHER PART #	QTY	DESCRIPTION 1 DESCRIPTION 2	MFG-NAME MFG-PART#	REF-DES	ST-DATE	END-DATE
50	760104-525	3	SHIM-STAINLESS STEEL	CIPHER DATA PROD			
ALT	731586-406		SHIM-CLEAR MYLAR	CIPHER DATA PROD			
51	731042-700	1	LABEL, FUSE REPLACEMENT	CIPHER DATA PROD			
52	731911-002	AR	SHIM-TAPE GUIDE (.010)	CIPHER DATA PROD			
53	731911-003	AR	SHIM-TAPE GUIDE (.020)	CIPHER DATA PROD			
54	731911-001	AR	SHIM-TAPE GUIDE (.005)	CIPHER DATA PROD			
55	731911-106	2	SHIM .020THICK 1/4IN ID	CIPHER DATA PROD			
56	210555-036	1	TERM,SLIP-ON.187 TAB,REEL	HOLLINGSWORTH TERM. CO. S05304F-T1			
ALT	210555-034		TERMINAL-SLIP-ON,.187 TAB	HOLLINGSWORTH TERM. CO. S05304F			
57	210188	4	PLUG,BANANA	SMITH,HERMAN H. 100			
58	210223	1	PIN,GROOV 3/32X3/4	GROOV-PIN GP4-093X0750-12			
59	210837	1	RUBBER BUMPER	MINNESOTA MINING SJ-5112			
60	210229-523	8	TY-RAP-1/16 TO 5/8	ICO RALLY WRN 3 1/2			
61	210199-001	1	RING,RETAINING-CRESCENT	WALDES TRUARC 5103-25-H			
62	210201	1	REEL 10 1/2"	EDP 5198GS			
63	210229-400	1	CLAMP,CABLE-5/16	HEYMAN MANUFACTURING CO. 3325			
64	210003-001	1	SPRING,COMPRESSION	LEE SPRING CO. LC-032E-9MW			
65	210229-200	1	CLAMP,CABLE-3/16	HEYMAN MANUFACTURING CO. 3303			

QTY GIVEN IS NUMBER OF PARTS OR LENGTH OF MATERIAL IN FEET

ITEM	CIPHER PART #	QTY	DESCRIPTION 1 DESCRIPTION 2	MFG-NAME MFG-PART#	REF-DES	ST-DATE	END-DATE
66	210229-500	2	CLAMP,CABLE-7/16	HEYMAN MANUFACTURING CO. 3327			
67	209990-304	AR	ADHESIVE-PLASTIC/VINYL BONDER	LOCTITE 41450			
68	210444	AR	LUBRIPLATE	G.C. ELECTRONICS 23-2S			
69	209990-072	AR	ADHESIVE-LOCTITE	LOCTITE 222			
70	211151-225	1	FUSE,3AG,NORM-BLO,6A,250V	LITTLEFUSE 312006			
71	211151-223	1	FUSE,3AG,NORM-BLO,4A,250V	LITTLEFUSE 312004			
72	207403-011	8	WASHER,SPLIT LOCK #4	ANY ACCEPTABLE SOURCE WASHER #4 CAD.			
73	207602-011	15	WASHER,SPLIT LOCK #6	ANY ACCEPTABLE SOURCE WASHER #6 CAD.			
74	207102-011	8	WASHER,SPLIT LOCK #10	ANY ACCEPTABLE SOURCE WASHER #10 CAD.			
75	207402-021	7	WASHER,FLAT #4	ANY ACCEPTABLE SOURCE			
76	207605-021	8	WASHER,FLAT #6	ANY ACCEPTABLE SOURCE WASHER #6 CAD.			
77	207104-021	10	WASHER, FLAT,#10	ANY ACCEPTABLE SOURCE WASHER #10 CAD.			
78	207608-021	7	WASHER,FLAT,SMALL OD #6	ANY ACCEPTABLE SOURCE WASHER #6 CAD.			
79	207408-021	1	WASHER,FLAT,SMALL OD #4	ANY ACCEPTABLE SOURCE			
80	207604-081	1	NUT-HEX RADIO PATTERN 6-32	ANY ACCEPTABLE SOURCE NUT #6 CAD.			
81	207406-081	1	NUT,HEX,RADIO PAT. #4 4-40	ANY ACCEPTABLE SOURCE NUT #4 CAD.			
82	213271-404	7	SCREW-PAN HD,PHIL 4-40 X 1/4	ANY ACCEPTABLE SOURCE			
83	213271-406	4	SCREW-PAN HD PHIL 4-40 X 3/8 CAD BLK ZINC	ANY ACCEPTABLE SOURCE			

QTY GIVEN IS NUMBER OF PARTS OR LENGTH OF MATERIAL IN FEET

ITEM	CIPHER PART #	QTY	DESCRIPTION 1 DESCRIPTION 2	MFG-NAME MFG-PART#	REF-DES	ST-DATE	END-DATE
84	213091-406	6	SCREW-SKT HD CAP 4-40 X 3/8,CAD,BLK,ZINC	ANY ACCEPTABLE SOURCE			
85	213091-408	2	SCREW-SKT HD CAP 4-40 X 1/2,CAD,BLK,ZINC	ANY ACCEPTABLE SOURCE			
86	213091-410	8	SCREW-SKT HD CAP 4-40 X 5/8,CAD,BLK,ZINC	ANY ACCEPTABLE SOURCE			
87	213091-422	2	SCREW-SKT HD CAP 4-40 X 1 3/8,CAD,BLK,ZINC	ANY ACCEPTABLE SOURCE			
88							
89	213271-604	1	SCREW-PAN HEAD PHIL 6-32 X 1/4,CAD,BLK,ZINC	ANY ACCEPTABLE SOURCE			
90	213271-609	1	SCREW-PAN HEAD,PHIL 6-32 X 9/16,CAD,BLK,ZINC	ANY ACCEPTABLE SOURCE			
91							
92	213091-606	11	SCREW-SKT HD CAP, 6-32 X 3/8,CAD,BLK,ZINC	ANY ACCEPTABLE SOURCE			
93	213091-608	6	SCREW-SKT HD CAP 6-32 X 1/2,CAD,BLK,ZINC	ANY ACCEPTABLE SOURCE			
94	213091-610	6	SCREW-SKT HD CAP 6-32 X 5/8,CAD,BLK,ZINC	ANY ACCEPTABLE SOURCE			
95	213202-618	1	SCREW-FL HD SKT,82, 6-32 X 1-1/8,BLK ONLY	ANY ACCEPTABLE SOURCE			
96	213351-608	2	SCREW-SOC SET CUP PT, 6-32 X 1/2,CAD,BLK,ZINC	ANY ACCEPTABLE SOURCE			
97	213092-110	6	SCREW-SKT HD CAP, 10-32 X 5/8 BLK	ANY ACCEPTABLE SOURCE			
98	213091-108	4	SCREW-SKT HD CAP 10-32 X 1/2,CAD,BLK,ZINC	ANY ACCEPTABLE SOURCE			
99	213091-122	3	SCREW-SKT HD CAP, 10-32 X 1-3/8,CAD,BL,ZINC	00000 ESNA 79NTE-048			
100	207000-064	1	NUT-HEX,LIGHT,THIN	ANY ACCEPTABLE SOURCE			
101	213091-116	8	SCREW SOC HD,CAP 10-32 X 1,CAD,BLK,ZINC	ANY ACCEPTABLE SOURCE			
102	211076	4	SCREW,SHOULDER	ANATOM ELECTRONIC HDW 7456-SS-0832			

QTY GIVEN IS NUMBER OF PARTS OR LENGTH OF MATERIAL IN FEET

ITEM	CIPHER PART #	QTY	DESCRIPTION 1 DESCRIPTION 2	MFG-NAME MFG-PART#	REF-DES	ST-DATE	END-DATE
103	210028-200	2	WASHER-FLAT,NYLON	ANATOM ELECTRONIC HDW 2257-N194			
104	211044	1	SWITCH "REVERSE"	MOLEX,INC. 1820RL122332428516605 REVS			
105	211045	1	SWITCH "FORWARD"	MOLEX,INC. 1820RL122332428516605 FWD			
106	211046	1	SWITCH "HI DEN"	MOLEX,INC. 1820RL122332428516605 HDN			
107	211047	1	SWITCH - "LOAD"	MOLEX,INC. 1820RL125332428516605 LOD			
108	211048	1	SWITCH - "ON LINE"	MOLEX,INC. 1820RL125332428516605 DL			
109	211049	1	SWITCH "WRT EN"	MOLEX,INC. 1820RL125332428516605 WRT			
110	211050	1	SWITCH "REWIND"	MOLEX,INC. 1820RL125332428516605 RWD			
111	211051-500	1	SWITCH-LIGHTED PB	MOLEX 01-56-1031			
112	131502-000	1	CABLE ASSY-SWITCHES	CIPHER DATA PROD			
113	131503-000	1	CABLE ASSY-SWITCH LAMPS	CIPHER DATA PROD			
114	131504-000	1	CABLE ASSY-POWER SWITCH	CIPHER DATA PROD			
115	-		119 ARE BLANK.				
120	*****						
121	726010-100	1	CAPSTAN LOW INERTIA	CIPHER DATA PROD		L*45	12-31-83

QTY GIVEN IS NUMBER OF PARTS OR LENGTH OF MATERIAL IN FEET

ITEM	CIPHER PART #	QTY	DESCRIPTION 1 DESCRIPTION 2	MFG-NAME MFG-PART#	REF-DES	ST-DATE	END-DATE
1	731580-101	1	PWB-CONTROL/SERVO	CIPHER DATA PROD			
2	731520-400	1	HEAT SINKS	CIPHER DATA PROD			
3	731006-800	1	LABEL-ASSY	CIPHER DATA PROD			
4	760003-301	1	STRUT-CONT/SERVO,FMTR	CIPHER DATA PROD			
5	735000-403	4	SPACER	CIPHER DATA PROD			
6	731501-300	2	RETAINER-P/C CONNECTOR	CIPHER DATA PROD			
7							
8							
9	205026-999	54	TEST POINT .058 DIA PIN	AMP INC. 60802-2			
10	205133-060	3	CONNECTOR-9 PIN MALE	MOLEX,INC. 09-18-5992	P2,11,13		
11	205068	1	CONNECTOR-12 POSN	MOLEX,INC. 03-09-2121	P7		
12	205133-080	1	CONNECTOR-12 PIN MALE	MOLEX,INC. 09-18-5924	P3		
13	205070	1	CONNECTOR HOUSING-15 POSN	MOLEX,INC. 03-09-2151	P14		
14	205133-001	5	CONNECTOR-3 PIN MALE	MOLEX,INC. 09-18-5032	P6,8,9,10,12		
15	205133-030	2	CONNECTOR-5 PIN MALE	MOLEX,INC. 09-18-5503	P4,5		
16	205012	27	TERMINAL,MALE.093 DIA.,PC	MOLEX,INC. 02-09-2134	(SEE-NOTE#195),P7,14		
ALT	205012-001		TERMINAL-MALE,.093DIA,PC LOOSE	NOT ON FILE 159-1050P			
17	211011-014	2	SOCKET,14 PIN LOW PROFILE	AUGAT 214-AG39D	XU1,2		
18	201105-010	30	CAP-CER,DISK,.01UF,500V	CERA-MITE 5HKS-S10	C20-44,109,110,111, 46,48		

QTY GIVEN IS NUMBER OF PARTS OR LENGTH OF MATERIAL IN FEET

ITEM	CIPHER PART #	QTY	DESCRIPTION 1 DESCRIPTION 2	MFG-NAME MFG-PART#	REF-DES	ST-DATE	END-DATE
19	201158-001	9	CAP-MYLAR .001UF 100V 10X	CORNELL-DUBILIER ELECT. WMF1D1	C1,6,13,211,213,306, 308,411,413		
20	205133-950	1	CONN,WAFER 5 PIN,PC	MOLEX,INC. 09-18-5950	P15		
21	131580-401	1	CONNECTOR ASSY-5 POS	CIPHER DATA PROD	J15		
22	201159-680	1	CAP-MYLAR.068UF 100V 10X	CORNELL-DUBILIER ELECT. WMF1S68	C14		
23	201159-100	4	CAP-MYLAR.01UF 100V 10X	CORNELL-DUBILIER ELECT. WMF1S1	C205,206,405,406		
24	201159-022	1	CAP-MYLAR.0022UF 200V 10X	CORNELL-DUBILIER ELECT. WMF2D22	C304		
25	201158-100	2	CAP-MYLAR .1UF 100V 10X	CORNELL-DUBILIER ELECT. WMF1P1	C9,10		
26	201121-470	6	CP-DM 47PF 300V 5X	CORNELL-DUBILIER ELECT. CD15EC470J03	C7,11,100,102,104,318		
27	201122-100	2	CAP-DM 100PF 300V 5X	SANGAMO D153E101J0	C3,319		
28	201148-001	2	CAP-PC .001UF 50V5X	EL PAC C5A102J	C207,407		
29	201122-300	2	CAP-DM 300PF 300V 5X	SANGAMO D153E301J0	C16,17		
30	201122-330	3	CAP-M 330PF 300V 5X	NOT ON FILE D153E331J0	C106,107,108		
31	201123-500	2	CAP-DM 5000PF 500V 5X	CORNELL-DUBILIER ELECT. CD19FD502J03	C212,412		
32	201122-680	1	CAP DM 680PF 300V 5X	SANGAMO D153E681J0	C314		
33	201149-330	1	CAP-PC .033UF 50V 5X	EL PAC C5A333J	C2		
34	201149-220	4	CAP-PC .022UF 50V 5X	EL PAC C5A223J	C217,219,417,419		
35	201149-470	3	CAP-PC .047UF 50V 5X	EL PAC C5A473J	C218,307,418		
36	201148-120	1	CAP-PC .12UF 50V 5X	EL PAC C5A124J	C316		

QTY GIVEN IS NUMBER OF PARTS OR LENGTH OF MATERIAL IN FEET

ITEM	CIPHER PART #	QTY	DESCRIPTION 1 DESCRIPTION 2	MFG-NAME MFG-PART#	REF-DES	ST-DATE	END-DATE
37	201148-220	1	CAP-PC .22UF 50V 5X	EL PAC C5A224J	C317		
38	201148-330	2	CAP-PC .33UF 50V 5X	EL PAC C5A334J	C216,416		
39	201148-470	4	CAP-PC .47UF 50V 5X	EL PAC C5A474J	C215,309,315,415		
40	201140-100	2	CAP-PC,1.0 UF,50V,5X	ELECTRO CUBE,INC. 650B1A105J	C208,408		
41	201160-220	1	CAP-TANT 2.2UF 35V 10Z	NATIONAL COMPONENT IND. CS13BF225K	C8		
42	201160-100	1	CAP-TANT 1UF 35V 10Z	NATIONAL COMPONENT IND. CS13BF105K	C47		
43	201191-025	10	CAPACITOR-ALUM WITH EPOXY END SEAL,10UFD,25V	PANASONIC CO. ECEBIEV100SR	C101,103,201,202,301, 302,311,312,401,402		
44	201190-050	6	CAPACITOR-ALUM WITH EPOXY END SEAL,3.3UFD 50V	PANASONIC CO. ECEBIHV3R3SR	C210,214,305,310,410, 414		
45	201161-470	1	CAP-TANT 47UF 6V 10Z	NATIONAL COMPONENT IND. CS13BB476K	C4		
46	201161-120	1	CAP-TANT 12UF 20V 10Z	NATIONAL COMPONENT IND. CS13BE126K	C15		
47	201160-680	1	CAP-TANT 6.8UF 35V 10Z	NATIONAL COMPONENT IND. CS13BF685K	C5		
48	201191-063	6	CAPACITOR-ALUM WITH EPOXY END SEAL,22UFD,6.3V	PANASONIC CO. ECEBOJV220SR	C105,203,204,313,403, 404		
49	202017	1	DIODE-ZENER, 6.2V	MOTOROLA SEMI. IN827A	CR301		
50	202018-100	54	DIODE,SWITCHING, SMALL BODY (DO-35)	FAIRCHILD IN4148	CR2-14,20,22-26,100- 102,105-107,201,204, 205,207-211,302-310, 313-316,318,401,404, 405,407,408,410,411		
51							
52	202019	3	DIODE-ZENER, 6.8V	FAIRCHILD IN957B	CR206,317,406		
53	202009-999	14	DIODE RECTIFIER,1 AMP	MOTOROLA SEMI. 1N4001 THRU 1N4004	CR108-115,202,203, 311,312,402,403		

QTY GIVEN IS NUMBER OF PARTS OR LENGTH OF MATERIAL IN FEET

ITEM	CIPHER PART #	QTY	DESCRIPTION 1 DESCRIPTION 2	MFG-NAME MFG-PART#	REF-DES	ST-DATE	END-DATE
54	202007	2	DIODE,POWER	NOT ON FILE 1N1612	CR103,104		
55	202023	2	DIODE 5082-2835	NOT ON FILE 5082-2835	CR15,16		
56	204008-001	5	TRANSISTOR-NPN	NATIONAL SEMICONDUCTORS TN3053	Q15,101,201,315,401		
ALT	204008		TRANSISTOR-NPN,GENERAL PURPOSE	RCA 2N3053			
57	204009	2	TRANSISTOR POWER NPN	RCA 2N3054	Q106,109		
58	204010	5	TRANSISTOR POWER NPN	RCA 2N3055	Q100,103,111,314,318		
59	204012-999	9	TRANSISTOR,PNP SILICON	TEXAS INSTRUMENTS 2N3702	Q17,210,305-310,20		
60	204013-999	11	TRANSISTOR,NPN SILICON	TEXAS INSTRUMENTS 2N3704	Q8-11,13,14,16,18,19, 209,409		
61	204026-700	4	TRANSISTER-POWER,NPN	TEXAS INSTRUMENTS 2N5886	Q203,207,403,407		
62	204010-710	6	TRANSISTOR-POWER,PNP	NATIONAL SEMICONDUCTORS TN4036	Q102,104,107,108,110, 316		
63	204018	10	TRANSISTOR,N-CHAN,FLD EFF	NATIONAL SEMICONDUCTORS PN4303	Q12,208,301-304,311, 312,319,408		
ALT	204018-001		TRANSISTOR-N-CHAN FLD EFF	HOLMBERG 2N4303			
64	204025	1	TRANSISTOR POWER NPN	RCA 2N5321	Q317		
65	204026	1	TRANSISTOR POWER PNP	RCA 2N5323	Q313		
66	204007-700	2	TRANSISTOR-POWER,NPN	TEXAS INSTRUMENTS 2N2243	Q204,404		
67							
68	200071-470	2	RES-FC 47 OHM 1/4W 5X	NOT ON FILE RCR07G470JM	R332,365		
69	200072-100	14	RES-FC 100 OHM 1/4W 5X	NOT ON FILE RCR07G101JM	R101,105,111,116,121, 224,227,230,361,367, 424,427,430,83		

QTY GIVEN IS NUMBER OF PARTS OR LENGTH OF MATERIAL IN FEET

ITEM	CIPHER PART #	QTY	DESCRIPTION 1 DESCRIPTION 2	MFG-NAME MFG-PART#	REF-DES	ST-DATE	END-DATE
70	200072-160	1	RES-FC 160 OHM 1/4W 5Z	NOT ON FILE RCR07G161JM	R38		
71	200072-180	2	RES-FC 180 OHM 1/4W 5Z	NOT ON FILE RCR07G181JM	R201,401		
72	200072-330	4	RES-FC 330 OHM 1/4W 5Z	NOT ON FILE RCR07G331JM	R209,210,409,410		
73	200075-120	1	RES-FC 120.00K 1/4W 5Z	NOT ON FILE RCR07G124JM	R42		
74	200072-470	21	RES-FC 470 OHM 1/4W 5Z	NOT ON FILE RCR07G471JM	R5,37,44,52,77,205, 206,222,226,320,326- 331,359,405,406,422, 426		
75	200072-560	2	RES-FC 560 OHM 1/4W 5Z	NOT ON FILE RCR07G561JM	R207,407		
76	200073-100	31	RES-FC 1.00K 1/4W 5Z	NOT ON FILE RCR07G102JM	R3,4,6,11,24,36,39, 48,51,53,54,57,61,67, 68,109,213,229,335, 366,413,429,386,80, 85-91		
77	200073-120	1	RES-FC 1.20K 1/4W 5Z	NOT ON FILE RCR07G122JM	R301		
78	200073-150	6	RES-FC 1.50K 1/4W 5Z	NOT ON FILE RCR07G152JM	R108,235,237,352,435, 437		
79	200073-220	3	RES FC 2.20K 1/4W 5Z	NOT ON FILE RCR07G222JM	R56,102,106		
80	200073-300	3	RES-FC 3.00K 1/4W 5Z	NOT ON FILE RCR07G302JM	R239,360,439		
81	200073-330	1	RES-FC 3.30K 1/4W 5Z	NOT ON FILE RCR07G332JM	R110		
82	200073-390	2	RES-FC 3.90K 1/4W 5Z	NOT ON FILE RCR07G392JM	R203,403		
83	200073-430	2	RES-FC 4.30K 1/4W 5Z	NOT ON FILE RCR07G432JM	R242,442		
84	200073-910	1	RES-FC 9.1K,1/4W 5Z	NOT ON FILE RCR07G912JM	R350		
85	200073-470	5	RES-FC 4.70K 1/4W 5Z	NOT ON FILE RCR07G472JM	R50,103,107,246,384		

QTY GIVEN IS NUMBER OF PARTS OR LENGTH OF MATERIAL IN FEET

ITEM	CIPHER PART #	QTY	DESCRIPTION 1 DESCRIPTION 2	MFG-NAME MFG-PART#	REF-DES	ST-DATE	END-DATE
86	200073-510	3	RES-FC 5.10K 1/4W 5Z	NOT ON FILE RCR07G512JM	R341,215,415		
87	200073-560	2	RES-FC 5.60K 1/4W 5Z	NOT ON FILE RCR07G562JM	R339,370		
88	200073-820	4	RES-FC 8.20K 1/4W 5Z	NOT ON FILE RCR07G822JM	R244,245,444,445		
89	200074-100	27	RES-FC 10.00K 1/4W 5Z	NOT ON FILE RCR07G103JM	R33,49,59,63,69,70, 204,216,218,221,310, 322,323,325,334,336, 337,340,356,357,404, 416,418,420,421,47		
90	200075-160	2	RES-FC 160K 1/4W 5Z	NOT ON FILE RCR07G164JM	R348,349		
91	200074-150	1	RES-FC 15.00K 1/4W 5Z	NOT ON FILE RCR07G153JM	R382		
92	200074-180	6	RES-FC 18.00K 1/4W 5Z	NOT ON FILE RCR07G183JM	R232,234,369,371,432, 434		
93	200074-240	2	RES-FC 24.00K 1/4W 5Z	NOT ON FILE RCR07G243JM	R342,343		
94	200074-270	5	RES-FC 27.00K 1/4W 5Z	NOT ON FILE RCR07G273JM	R233,241,243,433,443		
95	200074-360	2	RES-FC 36.00K 1/4W 5Z	NOT ON FILE RCR07G363JM	R41,65		
96	200073-620	1	RES-FC 6.20K 1/4W 5Z	NOT ON FILE RCR07G622JM	R383		
97	200074-470	2	RES-FC 47.00K 1/4W 5Z	NOT ON FILE RCR07G473JM	R35,45		
98	200074-510	3	RES FC 51.00K 1/4W 5Z	NOT ON FILE RCR07G513JM	R211,411,66		
99	200073-240	2	RES FC 2.40K 1/4W 5Z	NOT ON FILE RCR07G242JM	R79,81		
100	200074-750	1	RES-FC 75.0K 1/4W 5Z	NOT ON FILE RCR07G753JM	R72		
101	200075-100	2	RES-FC 100.00K 1/4W 5Z	NOT ON FILE RCR07G104JM	R240,440		
102	200075-200	2	RES-FC 200.00K 1/4W 5Z	NOT ON FILE RCR07G204JM	R71,247		

QTY GIVEN IS NUMBER OF PARTS OR LENGTH OF MATERIAL IN FEET

ITEM	CIPHER PART #	QTY	DESCRIPTION 1 DESCRIPTION 2	MFG-NAME MFG-PART#	REF-DES	ST-DATE	END-DATE
103	200075-180	1	RES FC 180.00K 1/4W 5X	NOT ON FILE RCR07G184JM	R446		
104							
105	200075-330	2	RES-FC 330.00K 1/4W 5X	NOT ON FILE RCR07G334JM	R34,338		
106	200075-470	2	RES-FC 470.00K 1/4W 5X	NOT ON FILE RCR07G474JM	R217,417		
107	200075-680	2	RES-FC 680.00K 1/4W 5X	NOT ON FILE RCR07G684JM	R58,62		
108	200076-100	4	RES-FC 1.00MEG 1/4W 5X	NOT ON FILE RCR07G105JM	R219,354,419,82		
109	200076-120	1	RES-FC 1.20MEG 1/4W 5X	NOT ON FILE RCR07G125JM	R319		
110	200076-470	1	RES-FC 4.70MEG 1/4W 5X	NOT ON FILE RCR07G475JM	R46		
111	200082-470	1	RES-FC 470 OHM 1/2W 5X	NOT ON FILE RCR20G471JM	R363		
112	200083-100	6	RES FC 1.00K 1/2W 5X	NOT ON FILE RCR20G102JM	R223,228,358,364,423,428		
113	200022-162	1	RES-FF 162 OHM 1/4W 1X	ANY ACCEPTABLE SOURCE RN60D1620F	R381		
114	200022-261	2	RES FF 261 OHM 1/4W 1X	ANY ACCEPTABLE SOURCE RN60D2610F	R305,311		
115	200022-590	1	RES FF 590 OHM 1/4W 1X	ANY ACCEPTABLE SOURCE RN60D5900F	R380		
116	200023-200	2	RES FF 2K 1/4W 1X	ANY ACCEPTABLE SOURCE RN60D2001F	R115,120		
117	200014-301	2	RES-FF,30.1K,1/8W,1X MIL-R-10509 STYLE	R-OHM RN55D3012F	R345,347		
118	200023-332	1	RES FF 3.32K 1/4W 1X	NOT ON FILE RN60D3321F	R125		
119	200023-365	2	RES FF 3.65K 1/4W 1X	NOT ON FILE RN60D3651F	R376,378		
120	200022-511	2	RES FF 511 OHM 1/4W 1X	ANY ACCEPTABLE SOURCE RN60D5110F	R304,321		

QTY GIVEN IS NUMBER OF PARTS OR LENGTH OF MATERIAL IN FEET

ITEM	CIPHER PART #	QTY	DESCRIPTION 1 DESCRIPTION 2	MFG-NAME MFG-PART#	REF-DES	ST-DATE	END-DATE
121	200023-649	1	RES FF 6.49K 1/4W 1X	NOT ON FILE RN60D6491F	R123		
122	200024-100	4	RES FF 10K 1/4W 1X	NOT ON FILE RN60D1002F	R317,351,355,377		
123	200024-121	1	RES FF 12.1K 1/8W 1X	NOT ON FILE RN60D1212F	R309		
124	200023-147	2	RES FF 1.47K 1/4W 1X	ANY ACCEPTABLE SOURCE RN60D1471F	R307,313		
125	200024-169	2	RES FF 16.9K 1/4W 1X	NOT ON FILE RN60D1692F	R113,118		
126	200023-100	8	RES FF 1K 1/4W 1X	ANY ACCEPTABLE SOURCE RN60D1001F	R302,303,308,314,315,316,318,324		
127	200025-150	1	RES FF 150K 1/4W 1X	NOT ON FILE RN60D1503F	R353		
128	200148-100	9	RES-WW,.1 OHM 6.5W 5X	DALE ELEC. INC. RS-5	R225,231,236,362,368,373,425,431,436		
129	200128-250	2	RES-WW,.250HM,3.75W,5X	DALE ELEC. INC. CW-2B	R100,104		
130	200128-100	2	RES-WW,.100HM,3.75W,5X	DALE ELEC. INC. CW-2B .1-9K	R122,126		
131	200120-100	2	RES-WW,1 OHM,3.75W,5X	DALE ELEC. INC. CW-2B .1-9K	R208,408		
132	200202-500	3	POT-500 OHM CERMET	BOURNS INC. 3006P-1-501	R114,119,124		
133	200203-200	8	POT-2K CERMET	ELECTRA/MIDLAND CORP ET34P202	R60,64,202,306,312,333,379,402		
134	200072-390	3	RES-FC 390 OHM 1/4W 5X	NOT ON FILE RCR07G391JM	R74,75,76		
135	200073-180	1	RES-FC 1.80K 1/4 5X	NOT ON FILE RCR07G182JM	R385		
136	205250-500	1	RESISTOR NETWORK-220 OHM	BECKMAN INSTRUMENTS, INC. 899-1-R220	U1		
137	205250-600	1	RESISTOR NETWORK-330 OHM	BECKMAN INSTRUMENTS, INC. 899-1-R330	U2		
138	200128-500	2	RES-WW,.50HM,3.75W,5X	DALE ELEC. INC. CW-2B	R112,117		

QTY GIVEN IS NUMBER OF PARTS OR LENGTH OF MATERIAL IN FEET

ITEM	CIPHER PART #	QTY	DESCRIPTION 1 DESCRIPTION 2	MFG-NAME MFG-PART#	REF-DES	ST-DATE	END-DATE
139	203017	8	IC-HEX INVERTER	TEXAS INSTRUMENTS SN15836N	U4,9,11,19,31,37,49, 304		
140	203021	17	IC-QUAD 2-IMP NAND GT	TEXAS INSTRUMENTS SN15846N	U8,10,12,14,21-24,26, 30,41,45,50,51,53, 302,303		
141	203022	7	IC-TRIP 3-IMP NAND GT	TEXAS INSTRUMENTS SN15862N	U6,20,25,28,29,40,52		
142	203016	1	IC-DUAL 4-IMP NAND GT	TEXAS INSTRUMENTS SN15830N	U43		
143	203019	5	IC-DUAL-4-IMP NND PWR GT	TEXAS INSTRUMENTS SN15844N	U15,17,27,36,42		
144	203002	2	IC-RTR MNST MLTV	FAIRCHILD 9601PC	U7,48		
145	203037	1	IC-4-LINE-TO-10-LINE DCDR	TEXAS INSTRUMENTS SN7442N	U44		
146	203041	3	IC-TTL DUAL,J-K,MS,F/F	TEXAS INSTRUMENTS SN7476N	U16,38,39		
147	203055	4	IC-DUAL PRPHL DRVR	TEXAS INSTRUMENTS SN75451BP	U32,33,34,35		
148	203010	10	IC-DUAL OPERATIONAL AMPL	SIGNETICS N5558V	U18,201,202,203,301, 305,306,307,401,402		
149	203102-001	2	IC-DUAL MNST MLTV	TEXAS INSTRUMENTS SN74221N	U46,47		
150	203007-001	3	IC-VOLTAGE REGULATOR	NATIONAL SEMICONDUCTORS LM305H	U100,101,102		
151	203121	1	IC-TIMER LINEAR	FAIRCHILD UA555TC	U3		
152	203102-003	1	IC - QUAD, S-R LATCHES	TEXAS INSTRUMENTS SN74279N	U13		
153	200073-270	1	RES-FC 2.70K 1/4W 5%	NOT ON FILE RCR07G272JM	R43		
154	200073-680	1	RES-FC 6.80 1/4W 5%	NOT ON FILE RCR07G682JM	R40		
155	200074-560	2	RES-FC 56.00K 1/4W 5%	NOT ON FILE RCR07G563JM	R214,414		
156	200013-750	2	RES-FF,7.50K,1/8W,1% MIL-R-10509 STYLE	R-OHM RN55D7501F	R249,448		

QTY GIVEN IS NUMBER OF PARTS OR LENGTH OF MATERIAL IN FEET

ITEM	CIPHER PART #	QTY	DESCRIPTION 1 DESCRIPTION 2	MFG-NAME MFG-PART#	REF-DES	ST-DATE	END-DATE
157	210197-200	1	RELAY-2PDT 10AMP 24VOLT	POTTER BRUMFIELD R10-E1-W2-V700	K2		
158	200072-220	2	RES-FC 220 OHM 1/4W 5%	NOT ON FILE RCR07G221JM	R15,25		
159	211078-999	1	SOCKET RELAY	POTTER BRUMFIELD AMF 27E128			
160	211077-999	1	CLIP-RELAY	POTTER BRUMFIELD AMF 20C259			
161	200073-130	2	RES-FC 1.30K 1/4W 5%	NOT ON FILE RCR07G132JM	R372,374		
162	200014-150	4	RES-FF,15.0K,1/8W,1% MIL-R-10509 STYLE	R-OHM RN55D1502F	R248,250,447,449		
163	201103-100	1	CAP-CER .001UF 1000V GMV	CERA-MITE 5HK-D10	C12		
164							
165							
166	211015-001	1	SWITCH-DIP,4POS,SEALED	AMP INC. 3-435668-4	S1		
167							
168	210617	2	INSULATOR,MYLAR T066	THERMALLOY CO 43-66-2			
169	210875-401	9	INSULATOR-THERMALLY CONDUCTIVE (TO-3)	BERQUIST 7403-09FR-05			
170	720500-502	22	BUSHING-NYLON	CIPHER DATA PROD			
171	209993-120	AR	HEATSINK COMPOUND	DOW-CORNING CORP 340			
172	211116	15	TRANSIPAD TO-5	THERMALLOY CO 7717-44N WHT	Q15,101,201,202,204, 205,206,313,315,317, 401,402,404,405,406		
173	210147	6	HEAT SINK- TO-5	IERC TXBF-032-025B	Q202,206,313,317,402, 406		
174							
175	213271-409	8	SCREW-PAN HD PHIL, 4-40 X 9/16,CAD,BLK,ZINC	ANY ACCEPTABLE SOURCE			
176							

QTY GIVEN IS NUMBER OF PARTS OR LENGTH OF MATERIAL IN FEET							
ITEM	CIPHER PART #	QTY	DESCRIPTION 1 DESCRIPTION 2	MFG-NAME MFG-PART#	REF-DES	ST-DATE	END-DATE
177	207403-011	8	WASHER,SPLIT LOCK #4	ANY ACCEPTABLE SOURCE WASHER #4 CAD.			
178	207105-031	2	WASHER,INTERNAL LOCK #10	ANY ACCEPTABLE SOURCE WASHER #10 CAD.			
179	207406-081	4	NUT,HEX,RADIO PAT. #4 4-40	ANY ACCEPTABLE SOURCE NUT #4 CAD.			
180	213271-609	22	SCREW-PAN HEAD,PHIL 6-32 X 9/16,CAD,BLK,ZINC	ANY ACCEPTABLE SOURCE			
181	207604-081	22	NUT-HEX RADIO PATTERN 6-32	ANY ACCEPTABLE SOURCE NUT #6 CAD.			
182	207608-021	22	WASHER,FLAT,SMALL OD #6	ANY ACCEPTABLE SOURCE WASHER #6 CAD.			
183	207102-051	2	NUT,HEX-LG PAT 10-32	ANY ACCEPTABLE SOURCE NUT #10 CAD.			
184	208500-298	.9	WIRE BUS TND COPPER 22AWG	ALPHA WIRE CORP. 298			
185							
186	209100-552	.5	TUBING TFL 22 GA	ALPHA WIRE CORP. TFT-200/22-NAT			
187	207602-011	22	WASHER,SPLIT LOCK #6	ANY ACCEPTABLE SOURCE WASHER #6 CAD.			
188	208500-605	13	WIRE-JUMPER,INSULATED	SQUIRES ELECTRONICS 0.500X0.125PVC22			
189							
190							
191	204025-100	2	TRANSISTOR-POWER P-N-P	RCA 2N5322S	Q202,402		
192	204024-900	2	TRANSISTOR-POWER N-P-N	RCA 2N5320S	Q206,406		
193	204010-700	2	TRANSISTOR-POWER,PNP	TEXAS INSTRUMENTS 2N3494	Q205,405		
194	331580-301	REF	SCHEM-CONTROL/SERVO	CIPHER DATA PROD			
195	* * DO NOT MIX TERMINALS ITEM #16 (205012) & ALT PART (205012-001) IN ONE CONNECTOR						
196	* ALTERNATE TRANSISTOR REQUIRE TRANSIPAD						
197	*****						

QTY GIVEN IS NUMBER OF PARTS OR LENGTH OF MATERIAL IN FEET							
ITEM	CIPHER PART #	QTY	DESCRIPTION 1 DESCRIPTION 2	MFG-NAME MFG-PART#	REF-DES	ST-DATE	END-DATE
1	731580-101	1	PWB-CONTROL/SERVO	CIPHER DATA PROD			
2	731520-400	1	HEAT SINKS	CIPHER DATA PROD			
3	731006-800	1	LABEL-ASSY	CIPHER DATA PROD			
4	760003-301	1	STRUT-CONT/SERVO,FMTR	CIPHER DATA PROD			
5	735000-403	4	SPACER	CIPHER DATA PROD			
6	731501-300	2	RETAINER-P/C CONNECTOR	CIPHER DATA PROD			
7							
8							
9	205026-999	54	TEST POINT .058 DIA PIN	AMP INC. 60802-2			
10	205133-060	3	CONNECTOR-9 PIN MALE	MOLEX,INC. 09-18-5992	P2,11,13		
11	205068	1	CONNECTOR-12 POSN	MOLEX,INC. 03-09-2121	P7		
12	205133-080	1	CONNECTOR-12 PIN MALE	MOLEX,INC. 09-18-5924	P3		
13	205070	1	CONNECTOR HOUSING-15 POSN	MOLEX,INC. 03-09-2151	P14		
14	205133-001	5	CONNECTOR-3 PIN MALE	MOLEX,INC. 09-18-5032	P6,8,9,10,12		
15	205133-030	2	CONNECTOR-5 PIN MALE	MOLEX,INC. 09-18-5503	P4,5		
16	205012	27	TERMINAL,MALE,.093 DIA.,PC	MOLEX,INC. 02-09-2134	(SEE-NOTE#195),P7,14		
ALT	205012-001		TERMINAL-MALE,.093DIA,PC LOOSE	NOT ON FILE 159-1050P			
17	211011-014	2	SOCKET,14 PIN LOW PROFILE	AUGAT 214-AG39D	XU1,2		
18	201105-010	30	CAP-CER,DISK,.01UF,500V	CERA-MITE 5HKS-S10	C20-44,109,110,111, 46,48		

QTY GIVEN IS NUMBER OF PARTS OR LENGTH OF MATERIAL IN FEET

ITEM	CIPHER PART #	QTY	DESCRIPTION 1 DESCRIPTION 2	MFG-NAME MFG-PART#	REF-DES	ST-DATE	END-DATE
19	201158-001	9	CAP-MYLAR .001UF 100V 10Z	CORNELL-DUBILIER ELECT. WMF1D1	C1,6,13,211,213,306, 308,411,413		
20	205133-950	1	CONN,WAFER 5 PIN,PC	MOLEX,INC. 09-18-5950	P15		
21	131580-401	1	CONNECTOR ASSY-5 POS	CIPHER DATA PROD	J15		
22	201159-680	1	CAP-MYLAR.068UF 100V 10Z	CORNELL-DUBILIER ELECT. WMF1S68	C14		
23	201159-100	4	CAP-MYLAR.01UF 100V 10Z	CORNELL-DUBILIER ELECT. WMF1S1	C205,206,405,406		
24	201159-022	1	CAP-MYLAR.0022UF 200V 10Z	CORNELL-DUBILIER ELECT. WMF2D22	C304		
25	201158-100	2	CAP-MYLAR .1UF 100V 10Z	CORNELL-DUBILIER ELECT. WMF1P1	C9,10		
26	201121-470	6	CP-DM 47PF 300V 5Z	CORNELL-DUBILIER ELECT. CD15EC470J03	C7,11,100,102,104,318		
27	201122-100	2	CAP-DM 100PF 300V 5Z	SANGAMO D153E101J0	C3,319		
28	201148-001	2	CAP-PC .001UF 50V5Z	EL PAC C5A102J	C207,407		
29	201122-300	2	CAP-DM 300PF 300V 5Z	SANGAMO D153E301J0	C16,17		
30	201122-330	3	CAP-M 330PF 300V 5Z	NOT ON FILE D153E331J0	C106,107,108		
31	201123-500	2	CAP-DM 5000PF 500V 5Z	CORNELL-DUBILIER ELECT. CD19FD502J03	C212,412		
32	201122-680	1	CAP DM 680PF 300V 5Z	SANGAMO D153E681J0	C314		
33	201149-330	1	CAP-PC .033UF 50V 5Z	EL PAC C5A333J	C2		
34	201149-220	4	CAP-PC .022UF 50V 5Z	EL PAC C5A223J	C217,219,417,419		
35	201149-470	3	CAP-PC .047UF 50V 5Z	EL PAC C5A473J	C218,307,418		
36	201148-120	1	CAP-PC .12UF 50V 5Z	EL PAC C5A124J	C316		

QTY GIVEN IS NUMBER OF PARTS OR LENGTH OF MATERIAL IN FEET

ITEM	CIPHER PART #	QTY	DESCRIPTION 1 DESCRIPTION 2	MFG-NAME MFG-PART#	REF-DES	ST-DATE	END-DATE
37	201148-220	1	CAP-PC .22UF 50V 5Z	EL PAC C5A224J	C317		
38	201148-330	2	CAP-PC .33UF 50V 5Z	EL PAC C5A334J	C216,416		
39	201148-470	4	CAP-PC .47UF 50V 5Z	EL PAC C5A474J	C215,309,315,415		
40	201140-100	2	CAP-PC,1.0 UF,50V,5Z	ELECTRO CUBE,INC. 650B1A105J	C208,408		
41	201160-220	1	CAP-TANT 2.2UF 35V 10Z	NATIONAL COMPONENT IND. CS13BF225K	C8		
42	201160-100	1	CAP-TANT 1UF 35V 10Z	NATIONAL COMPONENT IND. CS13BF105K	C47		
43	201191-025	10	CAPACITOR-ALUM WITH EPOXY END SEAL,10UFD,25V	PANASONIC CO. ECEBIEV100SR	C101,103,201,202,301, 302,311,312,401,402		
44	201190-050	6	CAPACITOR-ALUM WITH EPOXY END SEAL,3.3UFD 50V	PANASONIC CO. ECEBIHV3R3SR	C210,214,305,310,410, 414		
45	201161-470	1	CAP-TANT 47UF 6V 10Z	NATIONAL COMPONENT IND. CS13BB476K	C4		
46	201161-120	1	CAP-TANT 12UF 20V 10Z	NATIONAL COMPONENT IND. CS13BE126K	C15		
47	201160-680	1	CAP-TANT 6.8UF 35V 10Z	NATIONAL COMPONENT IND. CS13BF685K	C5		
48	201191-063	6	CAPACITOR-ALUM WITH EPOXY END SEAL,22UFD,6.3V	PANASONIC CO. ECEBOJV220SR	C105,203,204,313,403, 404		
49	202017	1	DIODE-ZENER, 6.2V	MOTOROLA SEMI. IN827A	CR301		
50	202018-100	54	DIODE,SWITCHING, SMALL BODY (DO-35)	FAIRCHILD IN4148	CR2-14,20,22-26,100- 102,105-107,201,204, 205,207-211,302-310, 313-316,318,401,404, 405,407,408,410,411		
51							
52	202019	3	DIODE-ZENER, 6.8V	FAIRCHILD IN957B	CR206,317,406		
53	202009-999	14	DIODE RECTIFIER,1 AMP	MOTOROLA SEMI. 1N4001 THRU 1N4004	CR108-115,202,203, 311,312,402,403		

QTY GIVEN IS NUMBER OF PARTS OR LENGTH OF MATERIAL IN FEET

ITEM	CIPHER PART #	QTY	DESCRIPTION 1 DESCRIPTION 2	MFG-NAME MFG-PART#	REF-DES	ST-DATE	END-DATE
54	202007	2	DIODE,POWER	NOT ON FILE 1N1612	CR103,104		
55	202023	2	DIODE 5082-2835	NOT ON FILE 5082-2835	CR15,16		
56	204008-001	5	TRANSISTOR-NPN	NATIONAL SEMICONDUCTORS TN3053	Q15,101,201,315,401		
ALT	204008		TRANSISTOR-NPN,GENERAL PURPOSE	RCA 2N3053			
57	204009	2	TRANSISTOR POWER NPN	RCA 2N3054	Q106,109		
58	204010	5	TRANSISTOR POWER NPN	RCA 2N3055	Q100,103,111,314,318		
59	204012-999	9	TRANSISTOR,PNP SILICON	TEXAS INSTRUMENTS 2N3702	Q17,210,305-310,20		
60	204013-999	11	TRANSISTOR,NPN SILICON	TEXAS INSTRUMENTS 2N3704	Q8-11,13,14,16,18,19, 209,409		
61	204026-700	4	TRANSISTER-POWER,NPN	TEXAS INSTRUMENTS 2N5886	Q203,207,403,407		
62	204010-710	6	TRANSISTOR-POWER,PNP	NATIONAL SEMICONDUCTORS TN4036	Q102,104,107,108,110, 316		
63	204018	10	TRANSISTOR,N-CHAN,FLD EFF	NATIONAL SEMICONDUCTORS PN4303	Q12,208,301-304,311, 312,319,408		
ALT	204018-001		TRANSISTOR-N-CHAN FLD EFF	HOLMBERG 2N4303			
64	204025	1	TRANSISTOR POWER NPN	RCA 2N5321	Q317		
65	204026	1	TRANSISTOR POWER PNP	RCA 2N5323	Q313		
66	204007-700	2	TRANSISTOR-POWER,NPN	TEXAS INSTRUMENTS 2N2243	Q204,404		
67							
68	200071-470	2	RES-FC 47 OHM 1/4W 5%	NOT ON FILE RCR07G470JM	R332,365		
69	200072-100	14	RES-FC 100 OHM 1/4W 5%	NOT ON FILE RCR07G101JM	R101,105,111,116,121, 224,227,230,361,367, 424,427,430,83		

QTY GIVEN IS NUMBER OF PARTS OR LENGTH OF MATERIAL IN FEET

ITEM	CIPHER PART #	QTY	DESCRIPTION 1 DESCRIPTION 2	MFG-NAME MFG-PART#	REF-DES	ST-DATE	END-DATE
70	200072-160	1	RES-FC 160 OHM 1/4W 5%	NOT ON FILE RCR07G161JM	R38		
71	200072-180	2	RES-FC 180 OHM 1/4W 5%	NOT ON FILE RCR07G181JM	R201,401		
72	200072-330	4	RES-FC 330 OHM 1/4W 5%	NOT ON FILE RCR07G331JM	R209,210,409,410		
73	200075-120	1	RES-FC 120.00K 1/4W 5%	NOT ON FILE RCR07G124JM	R42		
74	200072-470	21	RES-FC 470 OHM 1/4W 5%	NOT ON FILE RCR07G471JM	R5,37,44,52,77,205, 206,222,226,320,326- 331,359,405,406,422, 426		
75	200072-560	2	RES-FC 560 OHM 1/4W 5%	NOT ON FILE RCR07G561JM	R207,407		
76	200073-100	31	RES-FC 1.00K 1/4W 5%	NOT ON FILE RCR07G102JM	R3,4,6,11,24,36,39, 48,51,53,54,57,61,67, 68,109,213,229,335, 366,413,429,386,80, 85-91		
77	200073-120	1	RES-FC 1.20K 1/4W 5%	NOT ON FILE RCR07G122JM	R301		
78	200073-150	6	RES-FC 1.50K 1/4W 5%	NOT ON FILE RCR07G152JM	R108,235,237,352,435, 437		
79	200073-220	3	RES FC 2.20K 1/4W 5%	NOT ON FILE RCR07G222JM	R56,102,106		
80	200073-300	3	RES-FC 3.00K 1/4W 5%	NOT ON FILE RCR07G302JM	R239,360,439		
81	200073-330	1	RES-FC 3.30K 1/4W 5%	NOT ON FILE RCR07G332JM	R110		
82	200073-390	2	RES-FC 3.90K 1/4W 5%	NOT ON FILE RCR07G392JM	R203,403		
83	200073-430	2	RES-FC 4.30K 1/4W 5%	NOT ON FILE RCR07G432JM	R242,442		
84	200073-910	1	RES-FC 9.1K,1/4W 5%	NOT ON FILE RCR07G912JM	R350		
85	200073-470	5	RES-FC 4.70K 1/4W 5%	NOT ON FILE RCR07G472JM	R50,103,107,246,384		

QTY GIVEN IS NUMBER OF PARTS OR LENGTH OF MATERIAL IN FEET

ITEM	CIPHER PART #	QTY	DESCRIPTION 1 DESCRIPTION 2	MFG-NAME MFG-PART#	REF-DES	ST-DATE	END-DATE
86	200073-510	3	RES-FC 5.10K 1/4W 5Z	NOT ON FILE RCR07G512JM	R341,215,415		
87	200073-560	2	RES-FC 5.60K 1/4W 5Z	NOT ON FILE RCR07G562JM	R339,370		
88	200073-820	4	RES-FC 8.20K 1/4W 5Z	NOT ON FILE RCR07G822JM	R244,245,444,445		
89	200074-100	27	RES-FC 10.00K 1/4W 5Z	NOT ON FILE RCR07G103JM	R33,49,59,63,69,70, 204,216,218,221,310, 322,323,325,334,336, 337,340,356,357,404, 416,418,420,421,47 R348,349		
90	200075-160	2	RES-FC 160K 1/4W 5Z	NOT ON FILE RCR07G164JM	R382		
91	200074-150	1	RES-FC 15.00K 1/4W 5Z	NOT ON FILE RCR07G153JM	R232,234,369,371,432, 434		
92	200074-180	6	RES-FC 18.00K 1/4W 5Z	NOT ON FILE RCR07G183JM	R342,343		
93	200074-240	2	RES-FC 24.00K 1/4W 5Z	NOT ON FILE RCR07G243JM	R233,241,243,433,443		
94	200074-270	5	RES-FC 27.00K 1/4W 5Z	NOT ON FILE RCR07G273JM	R41,65		
95	200074-360	2	RES-FC 36.00K 1/4W 5Z	NOT ON FILE RCR07G363JM	R383		
96	200073-620	1	RES-FC 6.20K 1/4W 5Z	NOT ON FILE RCR07G622JM	R35,45		
97	200074-470	2	RES-FC 47.00K 1/4W 5Z	NOT ON FILE RCR07G473JM	R211,411,66		
98	200074-510	3	RES FC 51.00K 1/4W 5Z	NOT ON FILE RCR07G513JM	R79,81		
99	200073-240	2	RES FC 2.40K 1/4W 5Z	NOT ON FILE RCR07G242JM	R72		
100	200074-750	1	RES-FC 75.0K 1/4W 5Z	NOT ON FILE RCR07G753JM	R240,440		
101	200075-100	2	RES-FC 100.00K 1/4W 5Z	NOT ON FILE RCR07G104JM	R71,247		
102	200075-200	2	RES-FC 200.00K 1/4W 5Z	NOT ON FILE RCR07G204JM			

QTY GIVEN IS NUMBER OF PARTS OR LENGTH OF MATERIAL IN FEET

ITEM	CIPHER PART #	QTY	DESCRIPTION 1 DESCRIPTION 2	MFG-NAME MFG-PART#	REF-DES	ST-DATE	END-DATE
103	200075-180	1	RES FC 180.00K 1/4W 5Z	NOT ON FILE RCR07G184JM	R446		
104							
105	200075-330	2	RES-FC 330.00K 1/4W 5Z	NOT ON FILE RCR07G334JM	R34,338		
106	200075-470	2	RES-FC 470.00K 1/4W 5Z	NOT ON FILE RCR07G474JM	R217,417		
107	200075-680	2	RES-FC 680.00K 1/4W 5Z	NOT ON FILE RCR07G684JM	R58,62		
108	200076-100	4	RES-FC 1.00MEG 1/4W 5Z	NOT ON FILE RCR07G105JM	R219,354,419,82		
109	200076-120	1	RES-FC 1.20MEG 1/4W 5Z	NOT ON FILE RCR07G125JM	R319		
110	200076-470	1	RES-FC 4.70MEG 1/4W 5Z	NOT ON FILE RCR07G475JM	R46		
111	200082-470	1	RES-FC 470 OHM 1/2W 5Z	NOT ON FILE RCR20G471JM	R363		
112	200083-100	6	RES FC 1.00K 1/2W 5Z	NOT ON FILE RCR20G102JM	R223,228,358,364,423, 428		
113	200022-162	1	RES-FF 162 OHM 1/4W 1Z	ANY ACCEPTABLE SOURCE RN60D1620F	R381		
114	200022-261	2	RES FF 261 OHM 1/4W 1Z	ANY ACCEPTABLE SOURCE RN60D2610F	R305,311		
115	200022-590	1	RES FF 590 OHM 1/4W 1Z	ANY ACCEPTABLE SOURCE RN60D5900F	R380		
116	200023-200	2	RES FF 2K 1/4W 1Z	ANY ACCEPTABLE SOURCE RN60D2001F	R115,120		
117	200014-301	2	RES-FF,30.1K,1/8W,1Z MIL-R-10509 STYLE	R-OHM RN55D3012F	R345,347		
118	200023-332	1	RES FF 3.32K 1/4W 1Z	NOT ON FILE RN60D3321F	R125		
119	200023-365	2	RES FF 3.65K 1/4W 1Z	NOT ON FILE RN60D3651F	R376,378		
120	200022-511	2	RES FF 511 OHM 1/4W 1Z	ANY ACCEPTABLE SOURCE RN60D5110F	R304,321		

QTY GIVEN IS NUMBER OF PARTS OR LENGTH OF MATERIAL IN FEET

ITEM	CIPHER PART #	QTY	DESCRIPTION 1 DESCRIPTION 2	MFG-NAME MFG-PART#	REF-DES	ST-DATE	END-DATE
121	200023-649	1	RES FF 6.49K 1/4W 1Z	NOT ON FILE RN60D6491F	R123		
122	200024-100	4	RES FF 10K 1/4W 1Z	NOT ON FILE RN60D1002F	R317,351,355,377		
123	200024-121	1	RES FF 12.1K 1/8W 1Z	NOT ON FILE RN60D1212F	R309		
124	200023-147	2	RES FF 1.47K 1/4W 1Z	ANY ACCEPTABLE SOURCE RN60D1471F	R307,313		
125	200024-169	2	RES FF 16.9K 1/4W 1Z	NOT ON FILE RN60D1692F	R113,118		
126	200023-100	8	RES FF 1K 1/4W 1Z	ANY ACCEPTABLE SOURCE RN60D1001F	R302,303,308,314,315, 316,318,324		
127	200025-150	1	RES FF 150K 1/4W 1Z	NOT ON FILE RN60D1503F	R353		
128	200148-100	9	RES-WW,.1 OHM 6.5W 5Z	DALE ELEC. INC. RS-5	R225,231,236,362,368, 373,425,431,436		
129	200128-250	2	RES-WW,.250HM,3.75W,5Z	DALE ELEC. INC. CW-2B	R100,104		
130	200128-100	2	RES-WW,.100HM,3.75W,5Z	DALE ELEC. INC. CW-2B .1-9K	R122,126		
131	200120-100	2	RES-WW,1 OHM,3.75W,5Z	DALE ELEC. INC. CW-2B .1-9K	R208,408		
132	200202-500	3	POT-500 OHM CERMET	BOURNS INC. 3006P-1-501	R114,119,124		
133	200203-200	8	POT-2K CERMET	ELECTRA/MIDLAND CORP ET34P202	R60,64,202,306,312, 333,379,402		
134	200072-390	3	RES-FC 390 OHM 1/4W 5Z	NOT ON FILE RCR07G391JM	R74,75,76		
135	200073-180	1	RES-FC 1.80K 1/4 5Z	NOT ON FILE RCR07G182JM	R385		
136	205250-500	1	RESISTOR NETWORK-220 OHM	BECKMAN INSTRUMENTS,INC. 899-1-R220	U1		
137	205250-600	1	RESISTOR NETWORK-330 OHM	BECKMAN INSTRUMENTS,INC. 899-1-R330	U2		
138	200128-500	2	RES-WW,.50HM,3.75W,5Z	DALE ELEC. INC. CW-2B	R112,117		

QTY GIVEN IS NUMBER OF PARTS OR LENGTH OF MATERIAL IN FEET

ITEM	CIPHER PART #	QTY	DESCRIPTION 1 DESCRIPTION 2	MFG-NAME MFG-PART#	REF-DES	ST-DATE	END-DATE
139	203017	8	IC-HEX INVERTER	TEXAS INSTRUMENTS SN15836N	U4,9,11,19,31,37,49, 304		
140	203021	17	IC-QUAD 2-IMP NAND GT	TEXAS INSTRUMENTS SN15846N	U8,10,12,14,21-24,26, 30,41,45,50,51,53, 302,303		
141	203022	7	IC-TRIP 3-IMP NAND GT	TEXAS INSTRUMENTS SN15862N	U6,20,25,28,29,40,52		
142	203016	1	IC-DUAL 4-IMP NAND GT	TEXAS INSTRUMENTS SN15830N	U43		
143	203019	5	IC-DUAL-4-IMP NAND PWR GT	TEXAS INSTRUMENTS SN15844N	U15,17,27,36,42		
144	203002	2	IC-RTR MNST MLTV	FAIRCHILD 9601PC	U7,48		
145	203037	1	IC-4-LINE-TO-10-LINE DCDR	TEXAS INSTRUMENTS SN7442N	U44		
146	203041	3	IC-TTL DUAL,J-K,MS,F/F	TEXAS INSTRUMENTS SN7476N	U16,38,39		
147	203055	4	IC-DUAL PRPHL DRVR	TEXAS INSTRUMENTS SN75451BP	U32,33,34,35		
148	203010	10	IC-DUAL OPERATIONAL AMPL	SIGNETICS N5558V	U18,201,202,203,301, 305,306,307,401,402		
149	203102-001	2	IC-DUAL MNST MLTV	TEXAS INSTRUMENTS SN74221N	U46,47		
150	203007-001	3	IC-VOLTAGE REGULATOR	NATIONAL SEMICONDUCTORS LM305H	U100,101,102		
151	203121	1	IC-TIMER LINEAR	FAIRCHILD UA555TC	U3		
152	203102-003	1	IC - QUAD, S-R LATCHES	TEXAS INSTRUMENTS SN74279N	U13		
153	200073-270	1	RES-FC 2.70K 1/4W 5Z	NOT ON FILE RCR07G272JM	R43		
154	200073-680	1	RES-FC 6.80 1/4W 5Z	NOT ON FILE RCR07G682JM	R40		
155	200074-560	2	RES-FC 56.00K 1/4W 5Z	NOT ON FILE RCR07G563JM	R214,414		
156	200013-750	2	RES-FF,7.50K,1/8W,1Z MIL-R-10509 STYLE	R-OHM RN55D7501F	R249,448		

QTY GIVEN IS NUMBER OF PARTS OR LENGTH OF MATERIAL IN FEET

ITEM	CIPHER PART #	QTY	DESCRIPTION 1 DESCRIPTION 2	MFG-NAME MFG-PART#	REF-DES	ST-DATE	END-DATE
157	210197	1	RELAY-12V	POTTER BRUMFIELD AMF R10-E1-W2-V185	K2		
158	200072-220	2	RES-FC 220 OHM 1/4W 5Z	NOT ON FILE RCR07G221JM	R15,25		
159	211078-999	1	SOCKET RELAY	POTTER BRUMFIELD AMF 27E128			
160	211077-999	1	CLIP-RELAY	POTTER BRUMFIELD AMF 20C259			
161	200073-130	2	RES-FC 1.30K 1/4W 5Z	NOT ON FILE RCR07G132JM	R372,374		
162	200014-150	4	RES-FF,15.0K,1/8W,1Z MIL-R-10509 STYLE	R-OHM RN55D1502F	R248,250,447,449		
163	201103-100	1	CAP-CER .001UF 1000V GMV	CERA-MITE 5HK-D10	C12		
164							
165							
166	211015-001	1	SWITCH-DIP,4POS,SEALED	AMP INC. 3-435668-4	S1		
167							
168	210617	2	INSULATOR,MYLAR T066	THERMALLOY CO 43-66-2			
169	210875-401	9	INSULATOR-THERMALLY CONDUCTIVE (TO-3)	BERQUIST 7403-09FR-05			
170	720500-502	22	BUSHING-NYLON	CIPHER DATA PROD			
171	209993-120	AR	HEATSINK COMPOUND	DOW-CORNING CORP 340			
172	211116	15	TRANSIPAD TO-5	THERMALLOY CO 7717-44N WHT	Q15,101,201,202,204, 205,206,313,315,317, 401,402,404,405,406 Q202,206,313,317,402, 406		
173	210147	6	HEAT SINK- TO-5	IERC TXBF-032-025B			
174							
175	213271-409	8	SCREW-PAN HD PHIL, 4-40 X 9/16,CAD,BLK,ZINC	ANY ACCEPTABLE SOURCE			
176							

QTY GIVEN IS NUMBER OF PARTS OR LENGTH OF MATERIAL IN FEET

ITEM	CIPHER PART #	QTY	DESCRIPTION 1 DESCRIPTION 2	MFG-NAME MFG-PART#	REF-DES	ST-DATE	END-DATE
177	207403-011	8	WASHER,SPLIT LOCK #4	ANY ACCEPTABLE SOURCE WASHER #4 CAD.			
178	207105-031	2	WASHER,INTERNAL LOCK #10	ANY ACCEPTABLE SOURCE WASHER #10 CAD.			
179	207406-081	4	NUT,HEX,RADIO PAT. #4 4-40	ANY ACCEPTABLE SOURCE NUT #4 CAD.			
180	213271-609	22	SCREW-PAN HEAD,PHIL 6-32 X 9/16,CAD,BLK,ZINC	ANY ACCEPTABLE SOURCE			
181	207604-081	22	NUT-HEX RADIO PATTERN 6-32	ANY ACCEPTABLE SOURCE NUT #6 CAD.			
182	207608-021	22	WASHER,FLAT,SMALL OD #6	ANY ACCEPTABLE SOURCE WASHER #6 CAD.			
183	207102-051	2	NUT,HEX-LG PAT 10-32	ANY ACCEPTABLE SOURCE NUT #10 CAD.			
184	208500-298	.9	WIRE BUS TND COPPER 22AWG	ALPHA WIRE CORP. 298			
185							
186	209100-552	.5	TUBING TFL 22 GA	ALPHA WIRE CORP. TFT-200/22-NAT			
187	207602-011	22	WASHER,SPLIT LOCK #6	ANY ACCEPTABLE SOURCE WASHER #6 CAD.			
188	208500-605	13	WIRE-JUMPER,INSULATED	SQUIRES ELECTRONICS 0.500X0.125PVC22			
189							
190							
191	204025-100	2	TRANSISTOR-POWER P-N-P	RCA 2N5322S	Q202,402		
192	204024-900	2	TRANSISTOR-POWER N-P-N	RCA 2N5320S	Q206,406		
193	204010-700	2	TRANSISTOR-POWER,PNP	TEXAS INSTRUMENTS 2N3494	Q205,405		
194	331580-301	REF	SCHEM-CONTROL/SERVO	CIPHER DATA PROD			
195	* * DO NOT MIX TERMINALS ITEM #16 (205012) & ALT PART (205012-001) IN ONE CONNECTOR						
196	* ALTERNATE TRANSISTORS REQUIRE TRANSIPAD						
197	*****						

ITEM	CIPHER PART #	QTY	DESCRIPTION 1 DESCRIPTION 2	MFG-NAME MFG-PART#	REF-DES	ST-DATE	END-DATE
1	154040-009	1	PWB ASSY-DATA DUAL, 9TK,RAW (NO SPEED KIT)	CIPHER DATA PROD			
2	154040-601	1	SPEED KIT-12.5 IPS	CIPHER DATA PROD			
3							
4	454040-000	REF	DASH NO INDEX/PWB ASSY- DATA DUAL	CIPHER DATA PROD			
5	354040-300	REF	SCHEMATIC-DATA,DUAL MODE	CIPHER DATA PROD			

ITEM	CIPHER PART #	QTY	DESCRIPTION 1 DESCRIPTION 2	MFG-NAME MFG-PART#	REF-DES	ST-DATE	END-DATE
1	154040-009	1	PWB ASSY-DATA DUAL, 9TK,RAW (NO SPEED KIT)	CIPHER DATA PROD			
2	154040-602	1	SPEED KIT-18.75IPS	CIPHER DATA PROD			
3							
4	454040-000	REF	DASH NO INDEX/PWB ASSY- DATA DUAL	CIPHER DATA PROD			
5	354040-300	REF	SCHEMATIC-DATA,DUAL MODE	CIPHER DATA PROD			

ITEM	CIPHER PART #	QTY	DESCRIPTION 1 DESCRIPTION 2	MFG-NAME MFG-PART#	REF-DES	ST-DATE	END-DATE
1	154040-009	1	PWB ASSY-DATA DUAL, 9TK,RAW (NO SPEED KIT)	CIPHER DATA PROD			
2	154040-603	1	SPEED KIT-25IPS	CIPHER DATA PROD			
3							
4	454040-000	REF	DASH NO INDEX/PWB ASSY- DATA DUAL	CIPHER DATA PROD			
5	354040-300	REF	SCHEMATIC-DATA,DUAL MODE	CIPHER DATA PROD			

ITEM	CIPHER PART #	QTY	DESCRIPTION 1 DESCRIPTION 2	MFG-NAME MFG-PART#	REF-DES	ST-DATE	END-DATE
1	154040-009	1	PWB ASSY-DATA DUAL, 9TK,RAW (NO SPEED KIT)	CIPHER DATA PROD			
2	154040-604	1	SPEED KIT-37.5IPS	CIPHER DATA PROD			
3							
4	454040-000	REF	DASH NO INDEX/PWB ASSY- DATA DUAL	CIPHER DATA PROD			
5	354040-300	REF	SCHEMATIC-DATA,DUAL MODE	CIPHER DATA PROD			