



**Century Data Systems**  
A Xerox Company

**Trident**

**Models T25, T50 and T80**  
**Installation and Operation**



**TRIDENT SERIES DISK DRIVES  
INSTALLATION AND OPERATION  
MANUAL  
FOR MODELS T25, T50, AND T80**

May 1979



## CONTENTS

Section		Page
1	INTRODUCTION . . . . .	1-1
	Description . . . . .	1-1
	Specifications . . . . .	1-2
	Unit Differences . . . . .	1-3
	Major Component Locations . . . . .	1-3
	Installation Tools and Test Equipment . . . . .	1-4
2	UNPACKING AND INSPECTION . . . . .	2-1
	Unpacking and Handling . . . . .	2-1
	Front and Rear Cover Removal . . . . .	2-2
	Removing Shipping Materials . . . . .	2-3
	Equipment Inspection and Cleaning . . . . .	2-3
	Preparation for Reshipment . . . . .	2-6
3	INSTALLATION . . . . .	3-1
	Installation Check List . . . . .	3-1
	Electromechanical Checks . . . . .	3-2
	Ground and Power Supply Isolation Checks . . . . .	3-2
	AC Power Connection . . . . .	3-2
	DC Voltage Checks . . . . .	3-4
	Offline Operational Checkout . . . . .	3-5
	System Cables and Cable Fabrication . . . . .	3-6
	Bused Signal Cables . . . . .	3-6
	Radial Data Cables . . . . .	3-6
	System Installation Cabling . . . . .	3-7
	Sector Length Selection . . . . .	3-8
	Online Operational Checkout . . . . .	3-9
	Ac-Dc Ground Disconnect . . . . .	3-9
	Checkout Procedure . . . . .	3-10
4	OPERATION . . . . .	4-1
	Operating Controls and Indicators . . . . .	4-1
	Operator Control Panel . . . . .	4-1
	Maintenance Switches . . . . .	4-1
	Disk Pack Handling . . . . .	4-2
	Installing a Disk Pack . . . . .	4-3
	Removing a Disk Pack . . . . .	4-3
	Disk Drive Operation . . . . .	4-3
	Disk Drive Power-Up . . . . .	4-3
	Disk Drive Power-Down . . . . .	4-4
	Clearing a Device Check . . . . .	4-4
	Offline Operation . . . . .	4-4
	Returning the Disk Drive Online . . . . .	4-4
Appendix		
A	TRIDENT STAND KIT ASSEMBLY	
B	DUAL-ACCESS ASSEMBLY	

## ILLUSTRATIONS

Figure		Page
1-1	Trident Disk Drives . . . . .	1-1
1-2	Locations of Major Components . . . . .	1-5
2-1	Trident Shipping Configuration . . . . .	2-1
2-2	Hoisting Unit with a Lifting Bar . . . . .	2-2
2-3	Rear Cover Screw Locations . . . . .	2-4
2-4	Front Cover Thubscrew Locations . . . . .	2-4
2-5	T-Block Assembly Shipping Restraints . . . . .	2-4
2-6	Card Cage Area Component Locations . . . . .	2-5
2-7	Power Supply Area Component Locations . . . . .	2-5
2-8	Spindle Locking Mechanism . . . . .	2-6
2-9	Shipping Space and Bolt Locations . . . . .	2-8
3-1	Ground Shorting Jumper Location . . . . .	3-3
3-2	Voltage Select Terminal Board TB2 . . . . .	3-4
3-3	Power Cable Terminal Board TB1 . . . . .	3-4
3-4	Dc Voltage Check Point . . . . .	3-4
3-5	Signal Cable Terminal End Details . . . . .	3-6
3-6	Data Cable Terminal End Details . . . . .	3-7
3-7	Trident System Cable Connections . . . . .	3-7
3-8	Unit Cable Connector Locations . . . . .	3-8
3-9	Logic III Board Sector Jumpers . . . . .	3-9
3-10	NRZDATA Check . . . . .	3-9
3-11	Data Separator Board Write Clock Phasing Jumpers . . . . .	3-10
4-1	Operator Control Panel . . . . .	4-1
4-2	Location of Maintenance Switches . . . . .	4-1

## TABLES

Table		Page
1-1	Operating Specifications . . . . .	1-2
1-2	Unit Differences by Part Number . . . . .	1-4
1-3	Special Tools and Test Equipment . . . . .	1-4
2-1	List of Packing Materials . . . . .	2-7
3-1	Installation Check List . . . . .	3-1
3-2	Signal Cable Terminator VN37 Pin Assignments . . . . .	3-6
3-3	Data Cable Terminator VN38 Pin Assignments . . . . .	3-7
3-4	Bytes-Per-Sector Select Jumpers . . . . .	3-9
4-1	Operating Controls and Indicators . . . . .	4-2

## SECTION 1

### INTRODUCTION

This manual contains specifications and recommended procedures for unpacking, checking out, and installing CalComp Model T25, T50, and T80 Disk Drives. Factory trained personnel should perform the initial disk drive installation and installation checkout, where possible. General operating instructions that are appropriate to all system operators and maintenance technicians are also included.

#### DESCRIPTION

The Trident Disk Drives described in this manual are modular memory devices designed for mass storage in data

processing systems, particularly minicomputer class systems. See Figure 1-1. These drives handle removable five-high disk packs that are functionally identical. However, the packs are color coded for the convenience of customers using more than one model drive; packs with black, white, and blue collars are available.

Trident Model T25 drives provide a nominal storage of 25 megabytes of data per pack. The Model T50 provides 50 megabytes of storage, and the Model T80 provides 75 megabytes of storage. Data transfer rates are 806 kilobytes per second for the T25 and T50 models and



Figure 1-1. Trident Disk Drives

1209 kilobytes per second for the T80. Other operating specifications are listed in Table 1-1.

largely by the capability of the computer/disk drive interfacing controller and cable length limitations.

### SPECIFICATIONS

Trident Disk Drives are low profile units, equally adaptable to desk top or rack-mounted installations. Their interface design is such that system size and complexity is determined

Table 1-1 lists the general electrical and physical characteristics of the T25, T50, and T80 disk drives. For equipment deviations by part number, see Unit Differences.

**TABLE 1-1. OPERATING SPECIFICATIONS**

Tracks per Cylinder	5 (plus servo track)
Cylinders per Pack	
• T25	408 (000 thru 407)
• T50 and T80	815 (000 thru 814)
Bytes per Track	
• T25 and T50	13,440 (107, 520 bits)
• T80	20,160 (161, 280 bits)
Bytes per Cylinder	
• T25 and T50	67,200 (537, 600 bits)
• T80	100,800 (806, 400 bits)
Bytes per Pack	
• T25	27.4 million (219.2 million bits)
• T50	54.7 million (437.6 million bits)
• T80	82.15 million (657.2 million bits)
Track Density	
• T25	185 tracks per inch
• T50 and T80	370 tracks per inch
Recording Density	
• T25 and T50	4040 bits per inch, nominal
• T80	6060 bits per inch, nominal
Minimum Access Time	6 milliseconds (single-track head repositioning)
Maximum Access Time	55 milliseconds (full track head repositioning)
Average Access Time	28 milliseconds
Pack Rotational Speed	3600 rpm, $\pm 5\%$
Maximum Latency Time	17.5 milliseconds
Average Latency Time	8.3 milliseconds
Recording Method	Bit serial Multiple Frequency Modulation (MFM)
Data Transfer Rate	
• T25 and T50	806,000 bytes/sec (6.45 million bits/sec)
• T80	1,209,000 bytes/sec (9.67 million bits/sec)
Bit Cell Time	
• T25 and T50	155 nanoseconds
• T80	103.3 nanoseconds
Drive Start Time	20 seconds (START to drive ready)
Drive Stop Time	20 seconds (STOP to disk stopped)
Ac Input Voltages	50 to 60 Hertz ( $\pm 0.5$ Hz), single phase (measured line-to-line line-to-neutral)

**TABLE 1-1. OPERATING SPECIFICATIONS (Continued)**

Ac Input Voltages (continued)	
• 200-volt Models	190v rms, +10 to -15 percent 200v rms, +10 to -15 percent 208v rms, +10 to -15 percent 220v rms, +10 to -15 percent 230v rms, +10 to -15 percent 240v rms, +10 to -15 percent
• 100-volt Models	106v rms, +10 to -15 percent 115v rms, +10 to -15 percent 126v rms, +10 to -15 percent
Starting Current	13 amperes for 12 seconds (200-volt models) 26 amperes for 12 seconds (100-volt models)
Running Current	4.25 amperes @ 50 Hz or 4 amperes @ 60 Hz (200-volt models) 8.5 amperes @ 50 Hz or 8 amperes @ 60 Hz (100-volt models)
Head Dissipation	2100 Btu (nominal) to 2550 Btu (maximum) per hour
Physical Dimensions	
Height	10.5 inches (26.7 centimeters)
Width	17.75 inches (45.1 centimeters)
Depth	32 inches (81.3 centimeters)
Weight	220 pounds (99.8 kilograms)
Ambient Limits	
Temperature	60°F to 100°F (16°C to 38°C) with maximum gradient of 20°F (11°C) per hour
Humidity	10 to 80 percent, relative, without condensation
Storage Limits	
Temperature	-40°F to 150°F (-40°C to 65°C)
Humidity	5 to 80 percent, relative, without condensation

### UNIT DIFFERENCES

There are currently 18 configurations of the Model T25, T50, and T80 Disk Drives in production. These units all contain the internal data separator feature and differ from one another only in the phasing and frequency of ac input power. To determine the exact ac power characteristics of your unit, check the nameplate on the back panel of the unit. Table 1-2 lists ac power differences between current production drives by part number.

### MAJOR COMPONENT LOCATIONS

Figure 1-2 shows the location of major disk drive components and should be studied by those unfamiliar with this unit. A brief description of each component shown in the figure follows.

- Control Panel location of all switches and indicators normally used by the operator.
- Pack Area Lid covers disk pack and seals pack area for positive air pressure. Lid is raised to load and unload pack.
- Front and Rear Covers dress covers that are removable for maintenance.
- Spindle disk pack is mounted. The spindle is turned by the Spindle Drive Motor through a 1:1 belt drive system



**TABLE 1-2. UNIT DIFFERENCES BY PART NUMBER**

Model	Part Number	Primary Voltage	Phasing
T25	13381-005	190/240 vac, 60 Hz	1∅, Line-to-Line
	13381-007	190/240 vac, 50 Hz	1∅, Line-to-Neutral
	13381-013	190/240 vac, 50 Hz	1∅, Line-to-Line
	13381-015	190/240 vac, 60 Hz	1∅, Line-to-Neutral
	13381-017	100/127 vac, 60 Hz	1∅, Line-to-Neutral
	13381-019	100/127 vac, 50 Hz	1∅, Line-to-Neutral
T50	12262-005	190/240 vac, 60 Hz	1∅, Line-to-Line
	12262-007	190/240 vac, 50 Hz	1∅, Line-to-Neutral
	12262-013	190/240 vac, 50 Hz	1∅, Line-to-Line
	12262-015	190/240 vac, 60 Hz	1∅, Line-to-Neutral
	12262-017	100/127 vac, 60 Hz	1∅, Line-to-Neutral
	12262-019	100/127 vac, 50 Hz	1∅, Line-to-Neutral
T80	13382-005	190/240 vac, 60 Hz	1∅, Line-to-Line
	13382-007	190/240 vac, 50 Hz	1∅, Line-to-Neutral
	13382-013	190/240 vac, 50 Hz	1∅, Line-to-Line
	13382-015	190/240 vac, 60 Hz	1∅, Line-to-Neutral
	13382-017	100/127 vac, 60 Hz	1∅, Line-to-Neutral
	13382-019	100/127 vac, 50 Hz	1∅, Line-to-Neutral

- **Air Shroud** surrounds the disk pack to contain and direct air flow to the pack from a blower. Also mounts pack area lid.
- **Head Carriage** mounts one servo and five read/write heads in precise alignment with disk pack. Carriage can move the heads in and out under control of the head positioning linear motor.
- **Logic Card Cage** contains disk drive control logic, read/write logic, and servo circuits mounted on six plug-in circuit boards. System I/O cables and exerciser also plug into this assembly.
- **Relay Assembly** mounts relay and solid-state switches that perform power-up and power-down sequencing.
- **Power Supply** provides all necessary dc power to operate the disk drive. Also mounts the emergency retract relay.

**INSTALLATION TOOLS AND TEST EQUIPMENT**

Special tools and test equipment required for a normal installation of the disk drive are listed in Table 1-3. This list does not include normal hand tools or other special tools that may be needed if difficulties are encountered. Refer to the maintenance manual for a complete list of special tools and test equipment.

**TABLE 1-3. SPECIAL TOOLS AND TEST EQUIPMENT**

Special Tools
Head Alignment Pliers (P/N 17209-001)
Head Mounting Torque Wrench (P/N 11521-001)
Torque Driver (P/N 91516-001)
Safety Pin (P/N 97722-001)
Test Equipment
<b>Head Support Assembly (20110-001)</b>
Model T2000B Exerciser (P/N 18327-001)
Model T2001A Head Alignment Meter (P/N 17335-001)
Trident Head Alignment Pack (P/N 12541-001)
Trident Disk (Scratch) Pack (P/N 12540-501)
Card Extender (P/N 12427-001)
Oscilloscope (Tektronix Model 465 or better)
Digital Multimeter (0.5% accuracy or better)

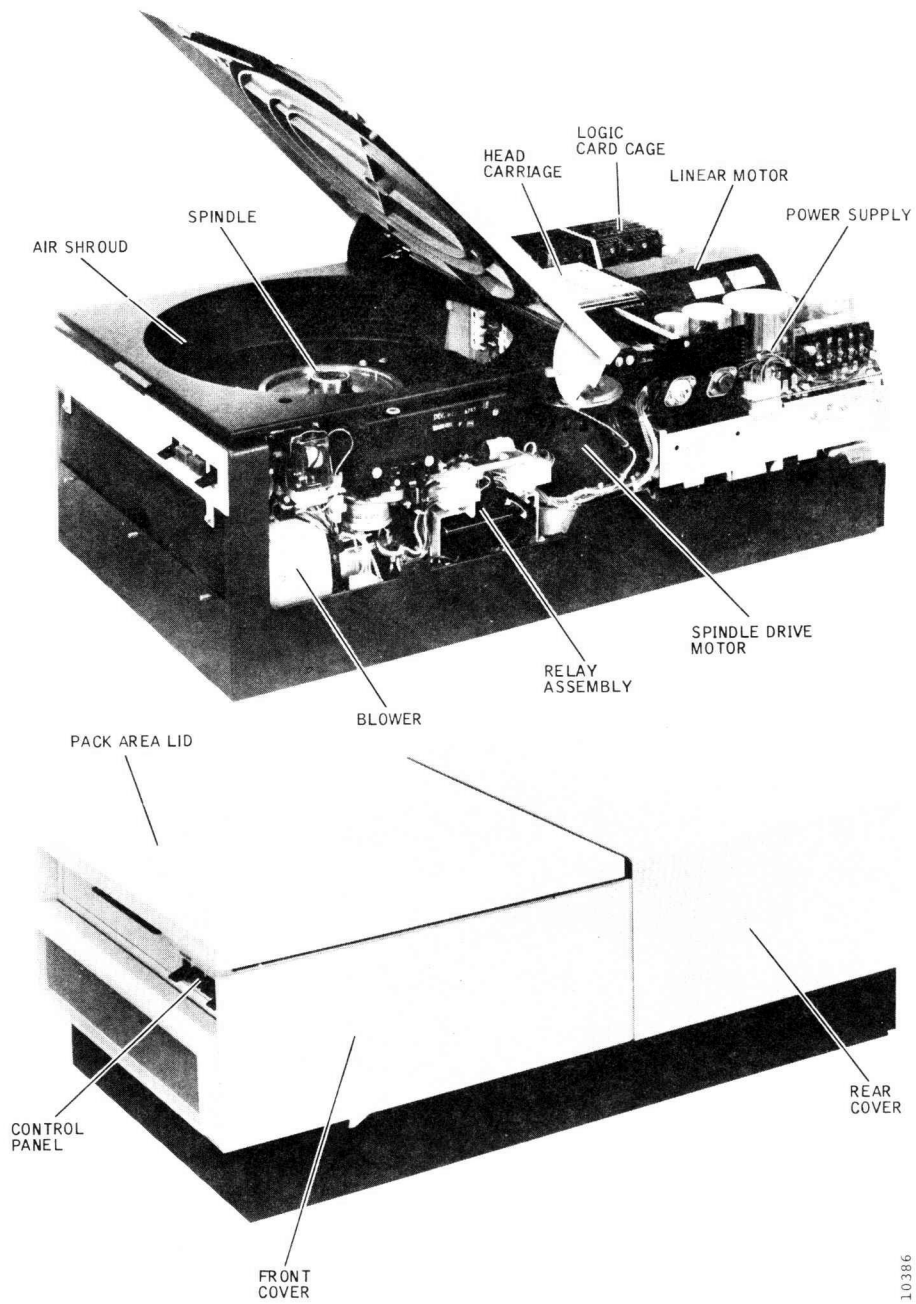

Figure 1-2. Locations of Major Components

## SECTION 2

### UNPACKING AND INSPECTION

Trident Disk Drives are normally packed in double-wall corrugated containers bolted to wooden pallets (Figure 2-1) for both domestic and overseas shipment and handling. These containers can be stacked. If the exterior condition of the container or the appearance of the pallet indicates the likelihood of interior damage to the unit, unpacking should be carried out in the presence of the carrier or his agent where possible. In any case, units should be unpacked and checked for shipping damage as soon as received.

In some cases the drives are shipped unboxed. Regardless of the method of outer packaging, the drives are always bolted to a plywood base. Procedures for unpacking the drives and removing the base are contained in the following paragraphs.

#### UNPACKING AND HANDLING

The following procedure is based upon current packing methods and is subject to possible minor changes. After inspecting the exterior of the container for obvious shipping damage, proceed as follows:

##### Note

*The unpacked unit weighs approximately 220 pounds. Once unpacked, unit handling is greatly simplified if a roll-around hydraulic or winch hoist is available for lifting the unit.*

1. Move the container by fork lift to the receiving station work bench (near final installation location, if possible).

##### Note

*It may prove expedient to save all of the packing material for possible reshipment.*

2. Remove the staples that attach the box enclosure flaps to the plywood base and lift the box enclosure up and off the disk drive.
3. Remove and retain any loose items and/or documentation from the top cushion of the packaging carton.

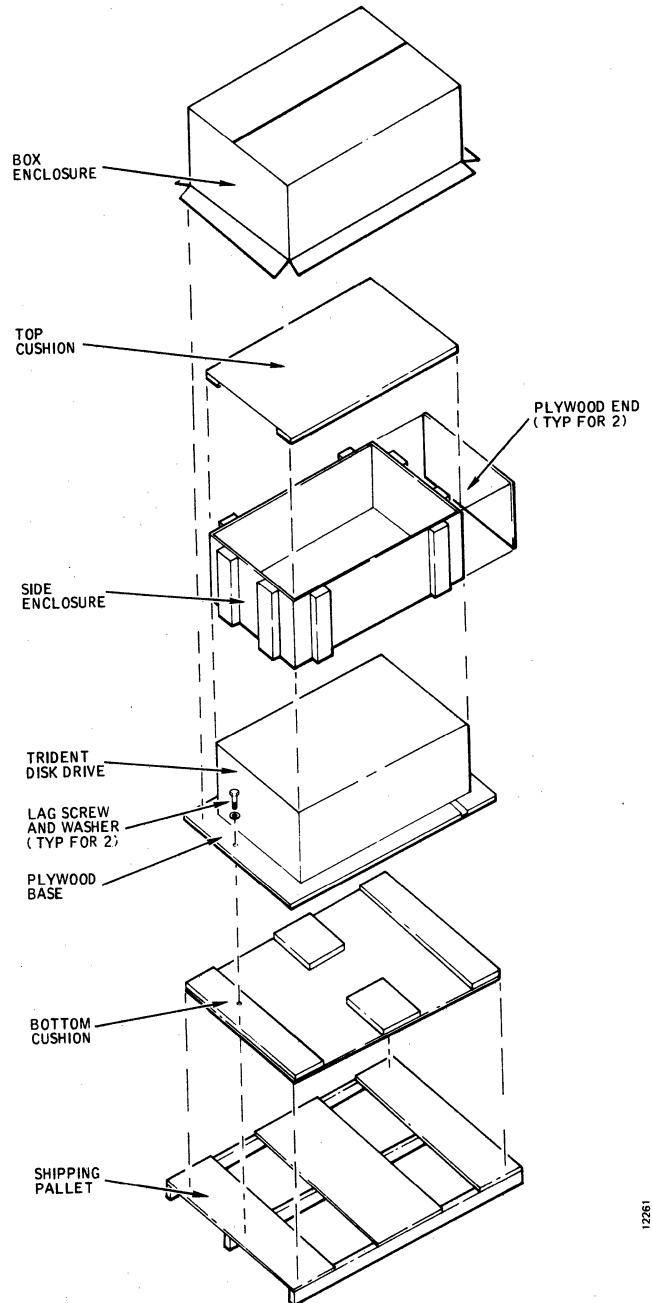

Figure 2-1. Trident Shipping Configuration

4. Remove the top cushion.
5. Remove the plywood end pieces from their positions against the side enclosure.
6. Pull straight up on the side enclosure and remove it from the disk drive.
7. Remove one lag screw from each end of the plywood base; these screws secure the base to the pallet. The drive and its plywood base may now be removed from the pallet. Remove the straps holding the plastic sheeting and retain the plastic sheeting to protect the machine.
8. Look on the bottom of the plywood base for two machine bolts that attach the base to the front of the unit frame. Remove both bolts.
9. Slide the unit and the plywood base over the edge of the pallet support surface just far enough to remove the two bolts that attach the back of the unit frame to the plywood base. Remove both bolts.
10. Lift the unit free of its plywood base and other packing materials, preferably by hoist in the manner described in steps 11 thru 13.

### WARNING

*If the unit must be lifted without a hoist, have at least three men on hand. The strongest man (or two men) should lift the rear of the unit, the second man should lift the front, and the third man should pull the packing material and base out from under the unit. Exercise care when lowering the unit not to smash anyone's fingers.*

11. If a lifting hoist is available, raise one end of the unit and slip the nylon webbing lifting straps under the unit. The loop diameter of the lifting straps must be at least the minimum shown in Figure 2-2, and a cradle (preferable) or lifting bar must be employed.
12. Take up slack in the lifting straps by raising the bar, and place several layers of corrugated cardboard between the top edges of the unit and each strap. The cardboard is used to protect the top covers from being distorted by the straps.
13. Lift the unit slightly and check for balance (the rear of the unit is heavier). Loosen and readjust the lifting bar for the proper balance point.

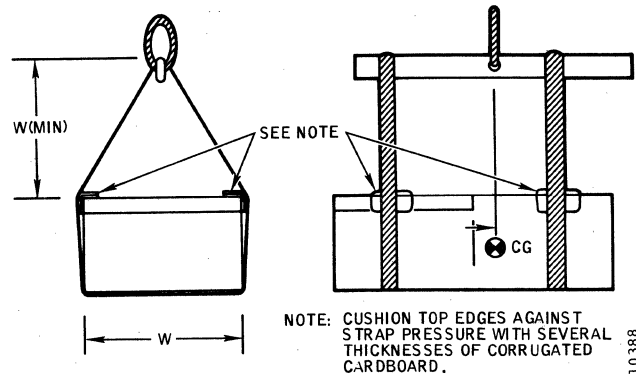

**Figure 2-2. Hoisting Unit with a Lifting Bar**

14. Lift the unit free of the plywood base and other packing material. Remove and discard this material.
15. Move the unit by hoist or dolly to the checkout work station or final installation location, as applicable.
16. If applicable, install four rubber feet, packed as loose items, by screwing them into the threaded holes at each corner of the bottom plate. This is done most easily while the unit is still suspended by the hoist. Otherwise, slide the front end of the unit over the edge of the supporting surface, install the two front feet; then raise the unit, and slide it back on the table. Repeat this procedure to install the two rear feet.
17. A 3/8-inch Allen head shipping bolt (Figure 2-3) located in the center of the unit rear panel locks the unit deck casting to the frame assembly during shipment. Using a 5/16-inch Allen wrench, remove and store the bolt, lockwasher, and flat washer.

### FRONT AND REAR COVER REMOVAL

1. The front cover of the unit can be removed by unscrewing the three thumbnuts underneath the front-end bezel (Figure 2-4) and then pulling the cover straight forward until it is clear of the unit.
2. The rear cover of the unit can be removed by unscrewing two screws at the rear of the cover (Figure 2-3) and then sliding the cover rearward and lifting it up.
3. Front and rear cover replacement is just the reverse of the removal procedure. The covers should go back on without forcing them.

## REMOVING SHIPPING MATERIALS

1. Remove and discard the wooden shipping spacer located at the rear of the unit, between the base casting and the unit frame.
2. Remove the glass tape that holds the plug-in module printed circuit boards in place in the card cage assembly.
3. Remove the transparent air shroud that encloses the retracted heads and T-block assembly. Cut the glass tape that secures T-block assembly in the retracted position (Figure 2-5).

### CAUTION

*While removing glass tape, hold the T-block assembly in the retracted position. Otherwise, it is easy to pull the heads forward off their camming surfaces with the likelihood of head damage.*

4. Remove the glass tape from the T-block assembly and the linear motor. Reinstall the transparent air shroud.
5. Unlatch and open the pack area lid and check for tape or other packing material inside the disk pack air shroud. Remove any materials found.

## EQUIPMENT INSPECTION AND CLEANING

1. Inspect the unit visually for evidence of rough handling during shipment, such as:
  - Deformed frame members or broken frame welds
  - Cracks or breaks in castings
  - Cracked printed circuit boards, particularly around mounting holes
  - Disconnected harness connectors or broken harness leads
2. Turn the captive screw securing the module card cage assembly to the frame (Figure 2-6) one-quarter turn and raise the card cage assembly. Inspect the back panel carefully for the following:
  - Back panel wirewrap pins that are bent, loose, or shorted together
  - Wirewrap leads that are broken off at the pins

3. Remove the plastic cover from the bottom of the frame (Figure 2-6), and make sure that the three dc fuses are firmly seated in the fuse block. Also check that the Servo Preamp circuit board adjacent to the dc fuse block is not cracked and that all plug-in connectors are tight. Reinstall the plastic cover.
4. Inspect the Read/Write Matrix circuit board (Figure 2-6) for cracks, and verify that all plug-in connectors are tight.
5. Close the card cage assembly and secure it with a quarter turn of the captive screw.
6. Unscrew the captive screw that holds the Power Supply Assembly (Figure 2-7) in place and swing out the supply. Check that all connections, connectors, and plug-in relays are tight. Also inspect the Power Supply and Transformer Assembly for physical damage. Close and secure the Power Supply Assembly.
7. Swing out the Sequence Relay Assembly. Check that all connectors are tight and that no physical damage is evident. Close the Sequence Relay Assembly.
8. Unlatch and open the pack area lid. Check for the following:
  - Spindle and spindle motor turn freely by hand without any evidence of interference.

### Note

*If a slight drag is felt or a grating sound is heard, the Speed Transducer at the bottom end of the spindle has probably been bent or otherwise knocked out of adjustment. Correct this by performing the Speed Transducer Adjustment procedure given in the Maintenance Manual before proceeding further. Also check spindle grinding brush contact pressure and resistance.*

- Actuate the spindle locking mechanism (Figure 2-8) by hand by pressing back on the nylon piece. The spindle should turn no more than a few degrees before it locks and should rotate freely again when the lock is released.
9. Using a dental mirror and a flashlight, inspect the head surfaces for oxide buildup and dust particles while the heads are retracted. If the heads are dirty, clean them in place; refer to the head cleaning procedure given in the Maintenance Manual.

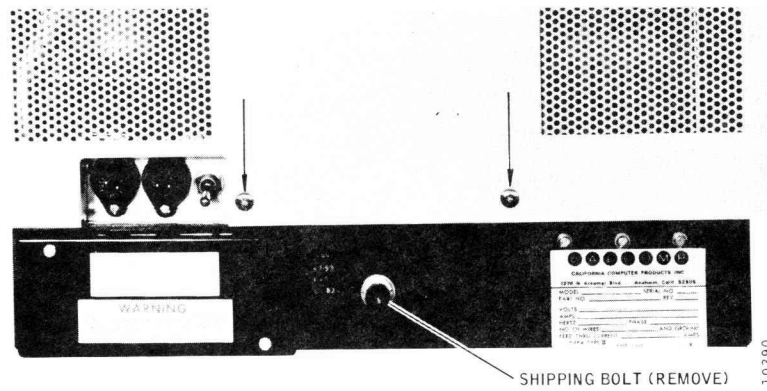

Figure 2-3. Rear Cover Screw Locations

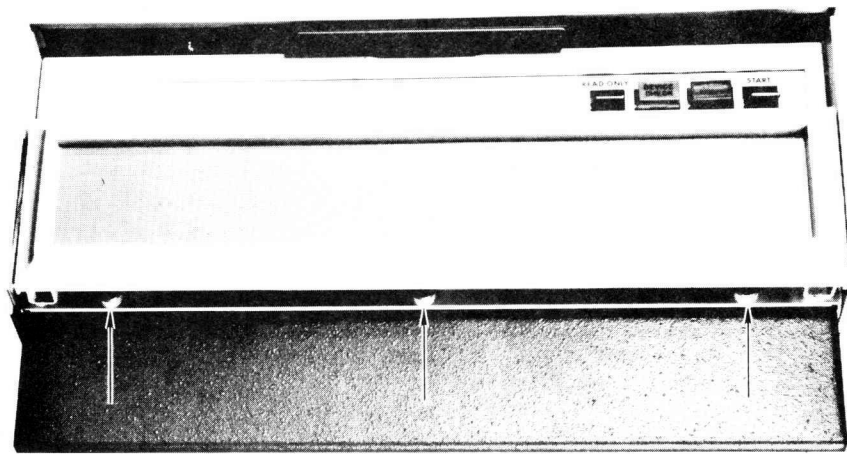

Figure 2-4. Front Cover Thumbscrew Locations

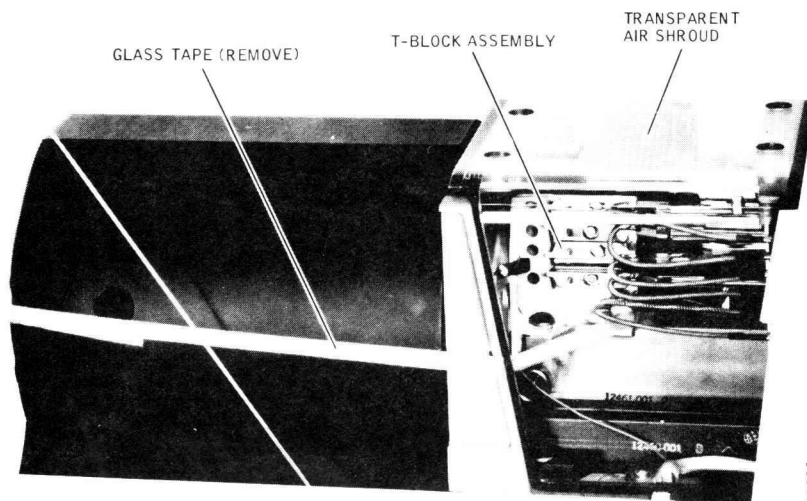
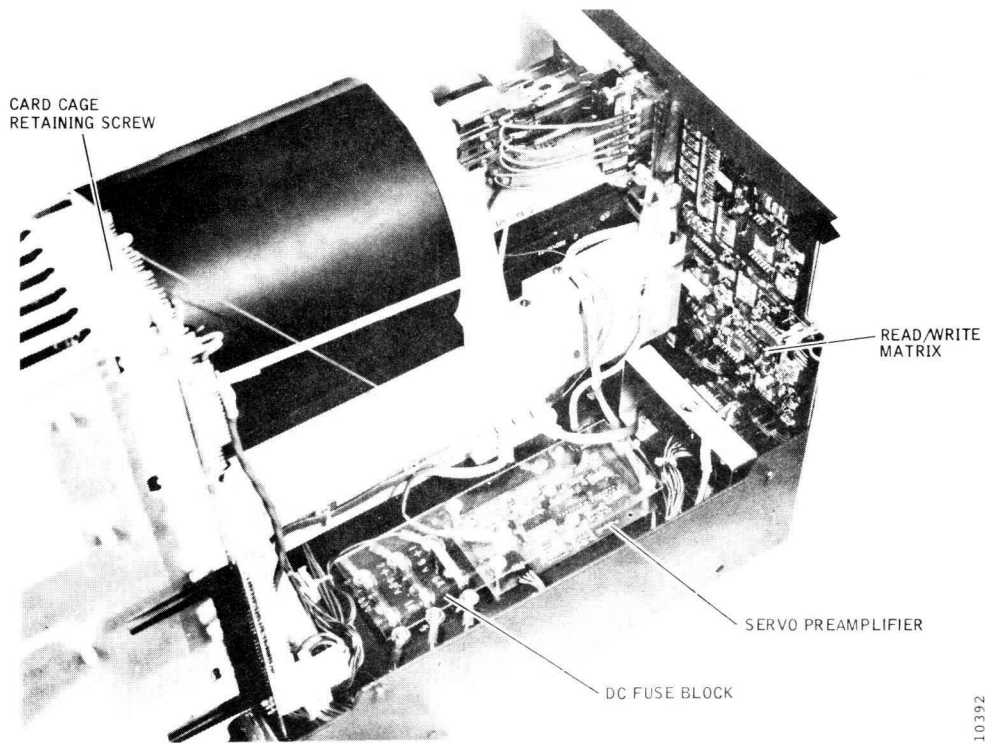
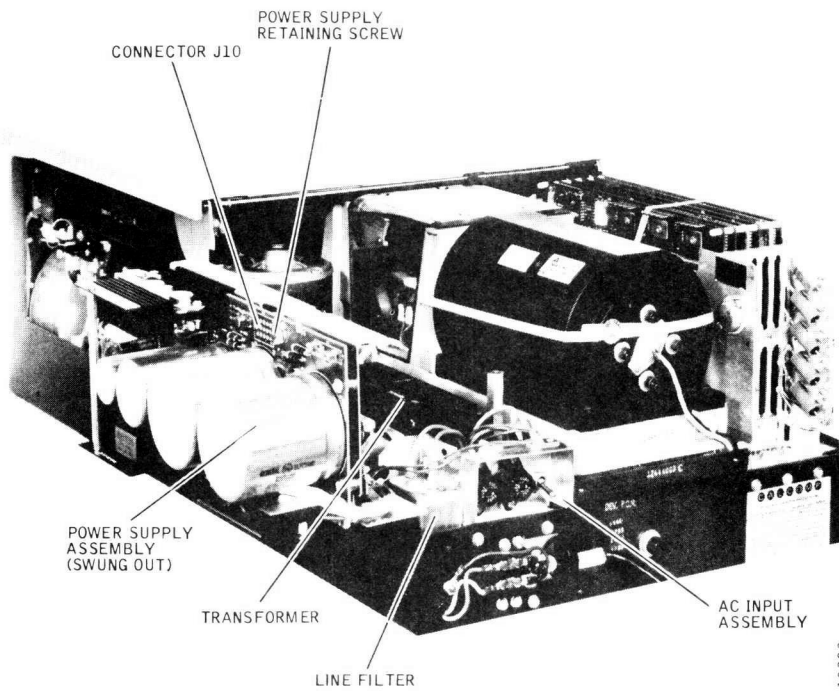

Figure 2-5. T-Block Assembly Shipping Restraints



10392

Figure 2-6. Card Cage Area Component Locations



10393

Figure 2-7. Power Supply Area Component Locations

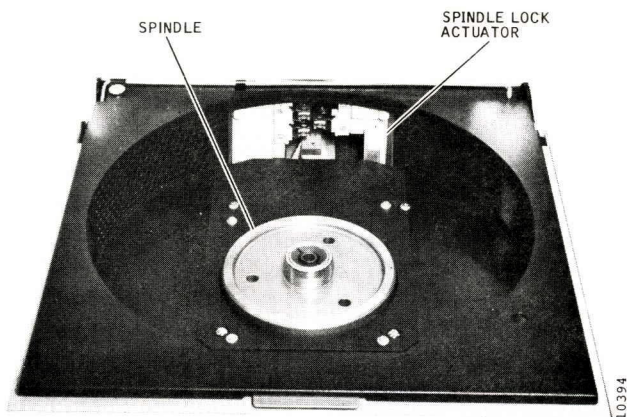

**Figure 2-8. Spindle Locking Mechanism**

10. If the interior of the air shroud or pack area lid is dirty or dusty, wipe the surfaces with a lint-free cloth slightly dampened with clean water and then dry them.
11. Close the pack area lid and latch it by pressing the lid down firmly.

### PREPARATION FOR RESHIPMENT

The following packing procedure is the one recommended and used by the factory for preparing units for shipment by common carrier. All packing materials are listed in Table 2-1. Some are available commercially, or they can be ordered from the factory or from your nearest factory representative. Preparatory to packing a unit for reshipment, review the Unpacking and Handling instructions and illustrations given in Section 2, and then proceed as follows:

1. Unplug the unit from the power outlet, and remove the front and rear covers.
2. Disconnect all interconnecting cables, cable terminator, and dc grounding strap from the cable connectors on the card cage.
3. Remove the transparent air shroud covering the carriage assembly (4 screws), and make sure the heads are fully retracted. Secure the head carriage assembly in the retracted position with two complete turns of 1/4-inch wide glass filament strapping tape. See Figure 2-5. Also check that the head cable plugs and their retaining bar are tight, and replace the air shroud carefully, so as not to damage its foam seals against the glass tape. Secure the transparent air shroud with the four screws.

4. Check that both the card cage assembly and the power supply are closed and latched tightly. Place a strip of glass filament strapping tape perpendicularly across the top edges of the circuit cards and at least 3 inches down each side of the card cage assembly to retain the cards. Tape them only tight enough to keep the cards in place, not so tight that the outside cards are bowed inward.
5. Open the pack area lid to check that the pack has been removed, that there is no loose material inside the pack area, and that all screws surrounding the spindle are tight. Close and latch the lid.
6. Place a wooden shipping spacer between the base casting and the bottom frame, as shown in Figure 2-9. The spacer should be positioned flatwise or crosswise to best fill the space between the casting and the frame.
7. Install the 3/8-inch shipping bolt, with split lock washer and flat washer, through the hole in the center of the rear frame member and into the threaded hole in the base casting. Tighten the bolt just tight enough to flatten the split lock washer.
8. Replace the front and rear covers on the unit, and secure them both with original attaching hardware.
9. Attach a handwritten warning label on the lid to the effect that the shipping bolt is installed and that the lid is not to be opened without first removing this bolt.

### WARNING

*Observe the Warning given in the Unpacking and Handling procedure to prevent personal injury while lifting the unit. Use a hoist with lifting bar or cradle, if one is available.*

10. Lift the unit and attach a plywood base (Figure 2-1) to the bottom of the unit with four 3/8"-16 by 1-inch bolts. The grooved end of the base is toward the rear of the unit.
11. Cover the unit with a plastic bag or heavy plastic sheeting to protect the finish, and secure in place with two 3/4-inch wide nylon straps: one wrapped around the front end to hold the lid closed, and the other wrapped lengthwise around the sides to hold the covers in place. Do not overtighten these straps.



**TABLE 2-1. LIST OF PACKING MATERIALS**

Item Description	Part No.	Qty.
Trident Shipping Kit (includes the following items) <ul style="list-style-type: none"> <li>● Box enclosure</li> <li>● Side enclosure</li> <li>● Plywood end pieces (2)</li> <li>● Top cushion</li> <li>● Bottom cushion</li> </ul>	SP346SC	1
Plywood Shipping Base	13514-001	1
Shipping Pallet	13516-001	1
Lag Screws (3/8" x 4")	SP347SF or Coml	2
Machine Bolts (3/8" – 16 x 1")	SP312SF or Coml	4
Wooden Shipping Spacer	19211-001	1
Machine bolt (3&8" – 16) with head painted red	90449-055	1
Flat washer (3/8")	Coml	1
Split lock washer (3/8")	Coml	1
Heavy Plastic Bag	Coml	1
Nylon Strapping	Coml	As Req.

- |  |   |
|--|---|
| <p>12. Place the bottom cushion on top of the shipping pallet.</p> <p>13. Lower the machine with its attached plywood base onto the bottom cushion.</p> <p>14. On each end of the machine, install a lag bolt with a flat washer through the plywood base and the bottom cushion into the shipping pallet.</p> <p>15. Position the side enclosure around the machine and push it down into palce.</p> <p>16. Position the top cushion on top of the machine and place any documents or loose items on the cushion surface.</p> | <p>17. Set a plywood end piece in place at each end of the machine. Note that the height of any materials placed on the top cushion does not exceed the height of the plywood ends.</p> <p>18. While holding the plywood ends in place, push the box enclosure down over the packaged machine. Staple the box flaps to the shipping pallet with a stapler.</p> <p>19. After applying the necessary shipping labels or stencils and appropriate labels for careful handling, the unit is ready for shipment.</p> |
|--|---|

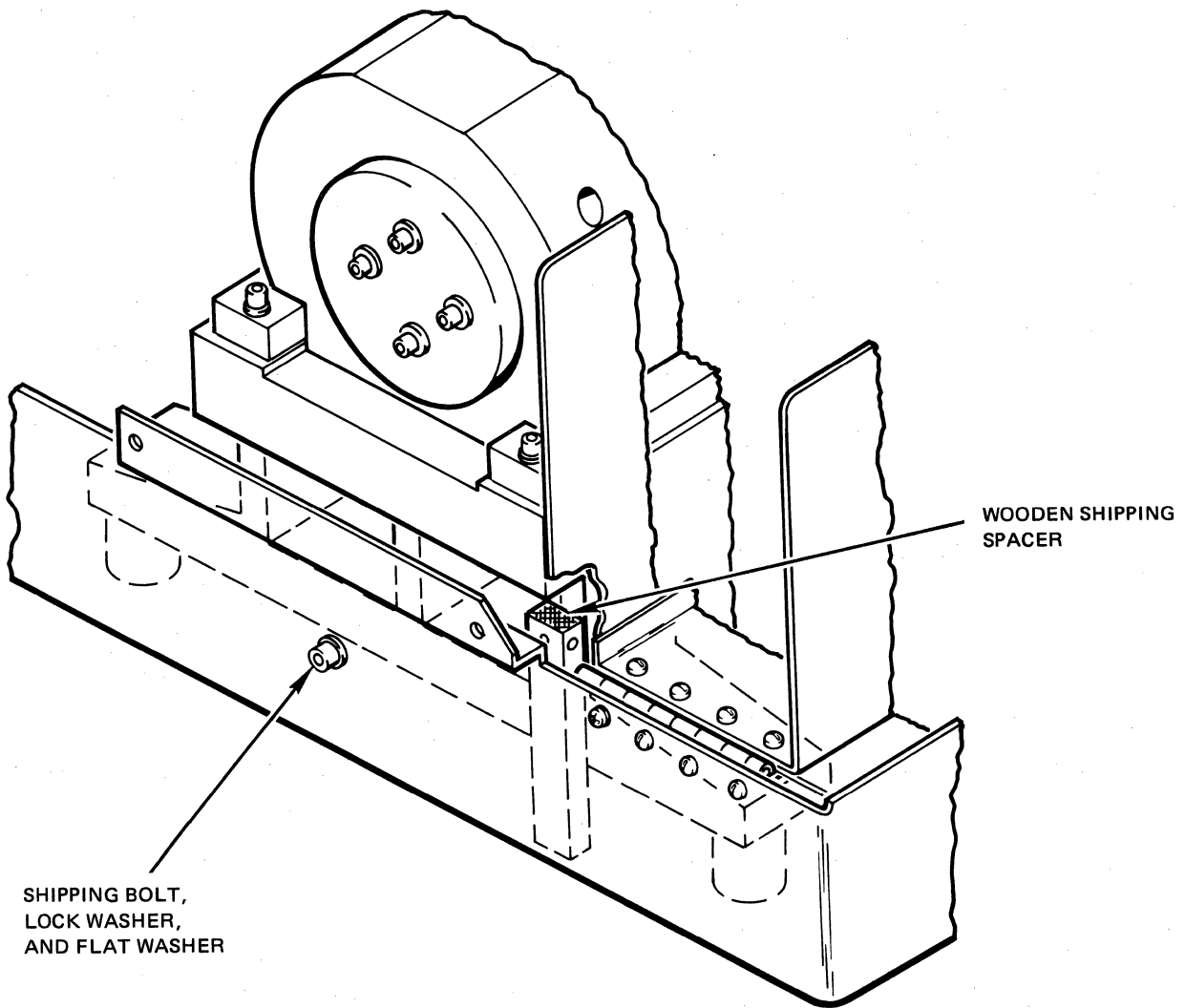

SHIPPING BOLT,  
LOCK WASHER,  
AND FLAT WASHER

WOODEN SHIPPING  
SPACER

Figure 2-9. Shipping Spacer and Bolt Locations.

12262

## SECTION 3 INSTALLATION

This section contains the recommended procedures for preinstallation unit checkout, unit installation, and installation checkout prior to online use of the disk drive. Installing technicians must be familiar with the unit operating procedures that are contained in Section 4.

Problems found during the preceding unit inspection must be corrected before proceeding further. If any adjustments or parts replacement are required to put the disk drive online, be sure to note all corrective actions taken on the Installation Completion Form.

### INSTALLATION CHECK LIST

An Installation Check List (Table 3-1) is provided for use as an installation guide by trained service personnel. This check list follows the more detailed installation procedures given in the remainder of this section.

**TABLE 3-1. INSTALLATION CHECK LIST**

#### VISUAL INSPECTION

- Remove all packing material
- Check for shipping damage
- Check all wiring and connectors
- Check spindle and spindle lock
- Inspect heads for dirt

#### ELECTROMECHANICAL CHECKS (Optional)

- Check lid latch and lid-closed microswitch
- Check brushes-extended microswitch
- Check heads-extended microswitch
- Check off-rack microswitch
- Check spindle grounding brush pressure and electrical resistance
- Check speed transducer gap and spindle drive belt

#### GROUND AND POWER SUPPLY ISOLATION CHECKS

- Check isolation between ac power lines and between power lines and chassis
- Check for isolation between chassis and logic ground

**TABLE 3-1. INSTALLATION CHECK LIST (Continued)**

#### AC POWER CONNECTION

- Jumper TB2 to match available input voltage
- Connect AC/DC GRD SHORT jumper
- Check TB1 for tight terminal connections

#### DC VOLTAGE CHECKS

- +9 volts (9 to 11 volts)
- +30 volts (+30 to +35 volts)
- 30 volts (-30 to -35 volts)
- +5 volts (+4.76 to +5.25 volts, ripple  $\leq$  75 mv pp)

#### OFFLINE OPERATIONAL CHECKOUT

- Ac and dc grounds shorted
- Manual head load to check for head/disk interference
- Check spindle power up/power down operation
- Check positioning access time
- Check for Seek Incomplete (720-millisecond delay)
- Check for Index pulses (4-microsecond width)
- Check for Sector pulses (1.24-microsecond width)
- Check for Attention set and reset
- Error-free random seek operation

#### SYSTEM CABLING

- Install bused signal cables and terminator
- Install radial data cables
- Install radial dc ground straps
- Open AC/DC GRD SHORT jumper

#### ONLINE OPERATION

- Recheck unit installation
- Check unit Device Check detection
- Check unit for seek positioning accuracy

**TABLE 3-1. INSTALLATION CHECK LIST (Continued)**

**ONLINE OPERATION**

- Check unit for worst-case pattern data recovery
- Check unit for crosstalk susceptibility
- Check unit for error-free random seek-and-read operation

**ELECTROMECHANICAL CHECKS**

The following electromechanical checks are optional and need be performed only if the unit was obviously dropped or subject to gross mishandling during shipment. Detailed procedures for making these checks and any necessary adjustments can be found in the maintenance manual.

1. Check that the air shroud lid is not deformed and appears to seal evenly when latched. Also check that the lid-closed microswitch is activated with the lid closed and latched. Readjust the lid-closed microswitch position, if necessary.
2. Check the brushes-extended microswitch for normal electrical operation and position adjustment.
3. Check the heads-extended microswitch for normal electrical operation and position adjustment.
4. Check the off-rack microswitch for normal electrical operation and position adjustment. Also note any roughness in carriage travel that might indicate that the linear motor bobbin or velocity transducer is dragging.
5. Check the spindle, by manually turning it, for freedom of rotation and absence of roughness or end play. Also check the spindle lock mechanism for normal operation and proper position adjustment.
6. Remove the bottom access cover, and check the spindle grounding brush contact pressure and electrical resistance.
7. Check the speed transducer for proper gap and position.
8. Check the spindle drive belt for proper centering and tension. Replace the bottom access cover.

**GROUND AND POWER SUPPLY ISOLATION CHECKS**

The following isolation checks are mandatory and must be performed on all units before ac power is connected.

1. Set the PWR ON/OFF switch at the rear of the unit to OFF.
2. Connect the power supply circuit board ground shorting jumper (Figure 3-1) to the spade terminal marked OPEN.
3. Using a high-quality VOM, measure the resistance between the prongs of the ac power plug. Resistance must be greater than 1 megohm between any two prongs.
4. Set the PWR ON switch to ON, and remeasure the resistance between the prongs of the ac power plug. Dc resistance should be at least 0.6 ohm.
5. Measure the resistance between the power supply frame and the deck plate casting. Resistance should be at least 1 megohm.
6. Measure the resistance between the power supply frame and the circuit card cage ground terminal marked E11. Resistance should be at least 1 megohm.
7. Disconnect Blower Motor cable P23, and measure the resistance between chassis (frame) ground and the spindle drive motor frame. Resistance should be less than 0.5 ohm. Reconnect P23.
8. Measure resistance between the spindle and the deck plate. Resistance should be less than 0.5 ohm.

**AC POWER CONNECTION**

The unit power cable should be connected to the primary ac power source only after the preceding isolation checks and the following steps have been performed. The installing technician must be competent in the method of load balancing, where a system of single-phase units is connected to a three-phase power source. Proceed as follows:

1. Make sure that the START/STOP switch on the control panel is set to STOP and that the PWR ON/OFF switch at the rear of the unit is in the OFF position.
2. Check the identification plate at the rear of the unit for voltage, phase, and frequency of input power required. Make sure these match the available power.
3. Check terminal board TB2 (Figure 3-2) on the power supply assembly for a jumper wire between the terminal marked  $\emptyset B/NTL$  and the terminal corresponding to the voltage available.

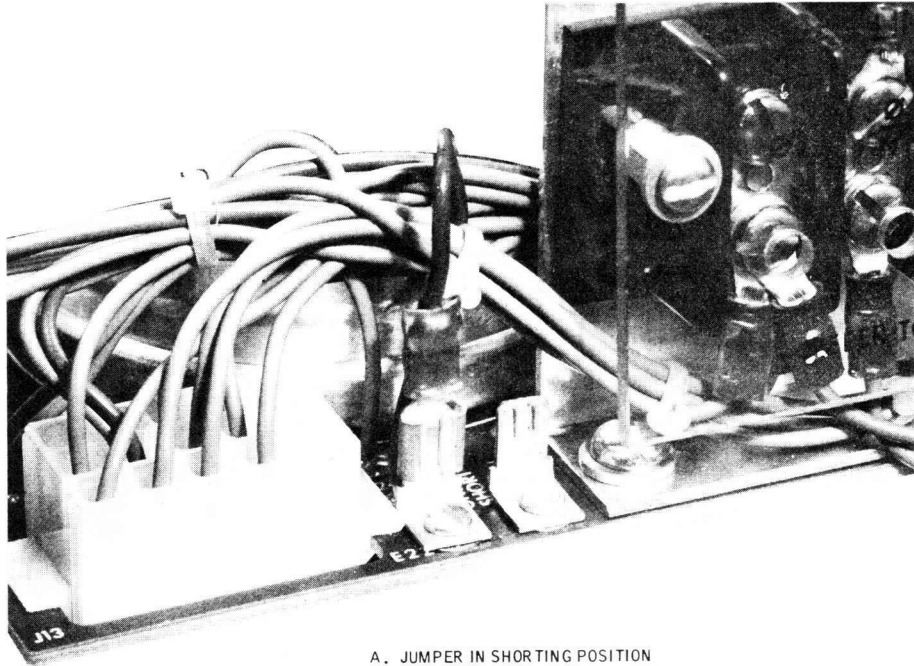

A. JUMPER IN SHORTING POSITION

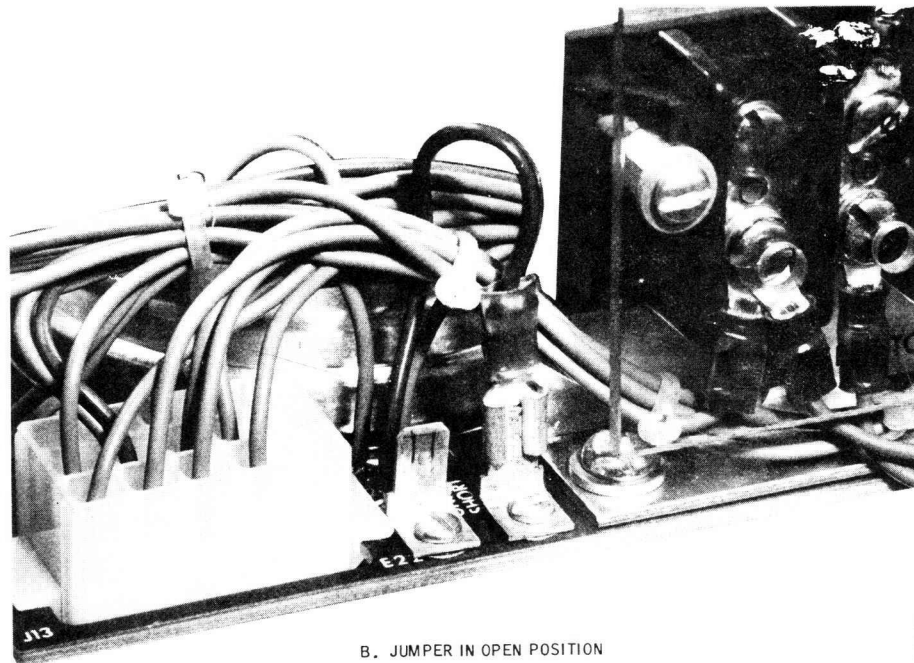

B. JUMPER IN OPEN POSITION

10395

Figure 3-1. Ground Shorting Jumper Location

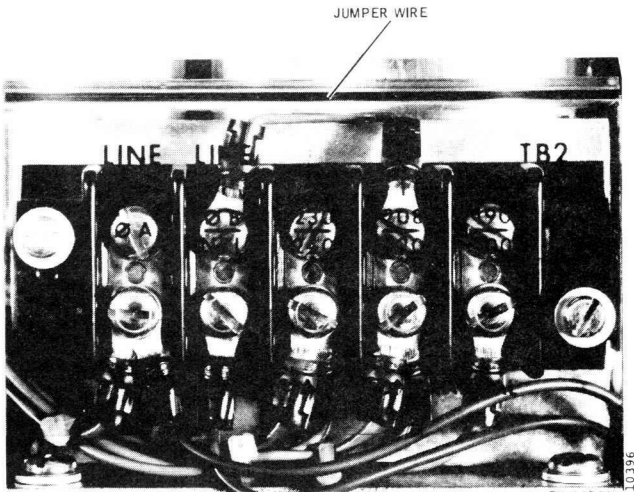

Figure 3-2. Voltage Select Terminal Board TB2

4. Disconnect the power supply circuit board ground shorting jumper from the OPEN spade terminal and reconnect it to the spade terminal marked AC/DC GRD SHORT. See Figure 3-1.

**WARNING**

*Never operate the disk drive as a standalone unit without ac and dc grounds being shorted together at the power supply. A potential as high as 60 volts can develop between the logic ground and the frame.*

5. Uncoil the unit power cable, remove the cover from power cable terminal board TB1, and make sure that all three wires are connected as shown in Figure 3-3 and that the terminals are tight. Reinstall the cover.
6. Connect the unit power cable to the ac power source.

**DC VOLTAGE CHECKS**

The following dc voltage checks are mandatory and must be performed on all units before offline operational checkout.

1. Set the PWR ON/OFF switch to ON. The blower motor should start, and the green File Ready indicator on the control panel may start flashing but should go out within 20 seconds.
2. Locate connector J10 on the Power Supply circuit board (see Figure 3-4) and check for in-tolerance dc voltages between the pins listed below:
  - +8.0 to +10.5 volts between pin 4 (+) and pin 9

- +30 to +35 volts between pin 1 (+) and pin 2
  - -30 to -35 volts between pin 3 and pin 2 (+)
3. Using a DVM, measure the voltage between logic ground (card cage terminal E11) and power pins on any circuit board connector (connector A or B, pin 59 or 60). Dc voltage should be +4.75 to +5.25 volts with an ac ripple component less than 75 millivolts peak to peak.

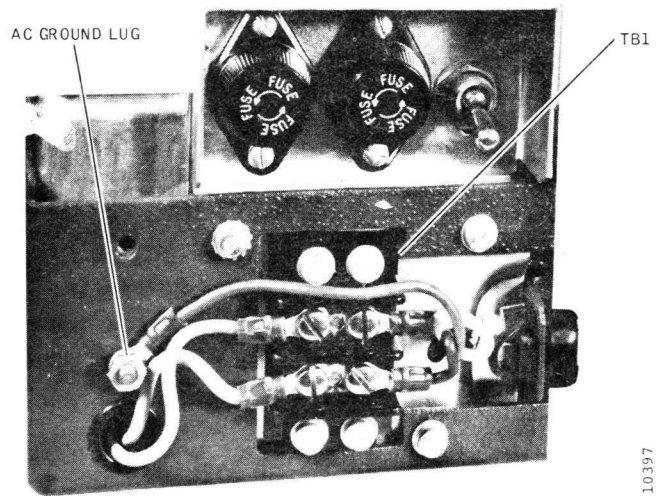

Figure 3-3. Power Cable Terminal Board TB1

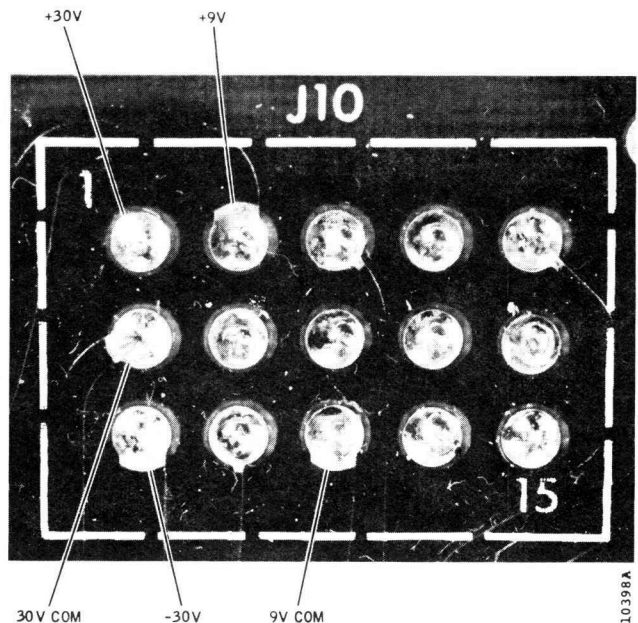

Figure 3-4. Dc Voltage Check Points

## OFFLINE OPERATIONAL CHECKOUT

All drives must be checked off line, using the Model T2000B Exerciser for control, to ensure that none have incurred damage in transit. All steps are mandatory and should be performed in the order given.

### WARNING

*Recheck that the ac and dc grounds are shorted together for offline operation at the power supply. See Figure 3-1.*

1. Set the PWR ON/OFF switch to OFF, and remove the Emergency Retract relay from the Power Supply (only relay on that assembly). This disables the servo and permits manual head loading.
2. Connect the Model T2000B Exerciser to disk drive connector J01 located on the base of the card cage assembly, and set the INTERFACE/DEGATE switch on top of the Logic I card to DEGATE. All exerciser toggle switches should be off (down).
3. Set the PWR ON/OFF switch to ON, install a scratch pack in the disk drive, close and latch the lid, and set the control panel START/STOP switch to START. The spindle drive motor should start turning and build to full speed in about 20 seconds, but the heads will not load, indicated by the continued flashing of the File Ready lamp.
4. Remove the transparent air shroud covering the retracted heads and T-block assembly.

### CAUTION

*During the next step, listen carefully for a tinging noise, which indicates that one or more heads are contacting the pack. Retract the heads immediately if head contact occurs.*

5. Move the heads forward at a normal rate off the head camming surfaces and onto the pack by hand, and listen for head-disk interference noise. If no noise is heard, move the heads back and forth on the pack (no more than 2 inches), and check for any feeling of mechanical interference or roughness in the carriage travel.
6. Fully retract the heads off the pack by hand at a normal rate, set the START/STOP switch to STOP, set the PWR ON/OFF switch to OFF, and reinstall the transparent air shroud and the Emergency Retract relay.

### Note

*If head contact was made with the disk pack, remove the pack, and attempt to clean the heads in place. Replace any head that cannot be cleaned, and correct the interference problem before proceeding further.*

7. With a pack installed, set the PWR ON/OFF switch to ON and immediately set the START/STOP switch to START. The green File Ready light should flash for about 20 seconds before the spindle motor starts. The indicator should continue to flash as the disk pack speed builds, and approximately 20 seconds later the heads should load automatically. When the heads are loaded, the indicator should light steadily.
8. Set the START/STOP switch to STOP, wait 3 seconds, and set it back to START. The disk drive should retract the heads, bring the disk pack to a stop in about 20 seconds, power back up, and reload the heads in approximately 20 more seconds.
9. Use the exerciser to perform continuous full-stroke, alternate seeks between cylinders 000 and 407 (T25) or 000 and 815 (T50 and T80) for at least 1 minute.
10. While step 9 seek operations are in progress, raise the card cage assembly to its open position and monitor the Position signal at pin 6B01 with an oscilloscope. Undulations of the Position signal should have a duration of no more than 55 milliseconds (maximum positioning access time allowed). If out of tolerance, perform the Seek Velocity Adjustment procedure given in the Maintenance Manual.
11. Stop the alternate seek operation, and Rezero the drive. Ground connector pin 3B09 (SRVOENA) on the back of the card cage to disable the servo system, and reconnect the scope to monitor the Seek Incomplete signal on pin 3B18.
12. Issue a Seek command with the exerciser. The Seek Incomplete signal should become active within 720 milliseconds after seek start. Remove the pin 3B09 ground and Rezero the drive.
13. Reconnect the scope to monitor the Index pulses at pin 3B10. Index pulses should be  $4 \pm 1$  microseconds wide.
14. Reconnect the scope to monitor the Sector pulses (SECTOR/) at pin 3B11. Sector pulses should be  $1.24 \pm 0.24$  microseconds wide.

15. Reconnect the scope to monitor the Attention signal at pin 3A52. Issue a Seek command with the exerciser. The Attention signal should go high when the seek has been completed. Issue a Read command with the exerciser. Attention should go low.
16. Rezero the drive and initiate continuous random seek operations with the exerciser. Continue for at least 5 minutes at the maximum seek rate setting. The drive should operate error free for this period of time (no seek incompletes or Device Checks). Stop seek operation and Rezero the drive.
17. Offline checkout of the drive is now complete. Set the START/STOP switch to STOP. After the pack has come to a stop, set the PWR ON/OFF switch to OFF, and disconnect the exerciser and other test leads.

### SYSTEM CABLES AND CABLE FABRICATION

Bused and radial line cables of the required number and lengths to interconnect the disk drive controller and several Trident disk drives are normally fabricated on site to match the physical arrangement of the system. Actual cable needs and fabrication instructions are given below.

#### Bused Signal Cables

Bused signal cables are needed to reach from the controller Busout connector to Busin of Drive A, from Busout of Drive A to Busin of Drive B, etc. In all, the same number of Bused Signal Cables will be required as there are disk drives in the system. The combined (total) length of these cables must not exceed 100 feet.

**TABLE 3-2. SIGNAL CABLE TERMINATOR VN37 PIN ASSIGNMENTS**

Pin No.	Signal Name	Pin No.	Signal Name
E01	ISECTOR/	E24	IBUS2/
E02	IEOC/	E26	IBUS3/
E03	IADMKDET/	E28	IBUS4/
E04	IOFFSET/	E30	IBUS5/
E06	IIDX/	E32	IBUS6/
E08	IRDY/	E34	IBUS7/
E10	IRONLY/	E35	ITERIN/
E12	IDEVCK/	E36	IBUS8/
E14	IONLINE/	E37	ICONTROLTAG/
E16	ISKINC/	E38	IBUS9/
E20	IBUS0/	E39	ISETCYLTAG/
E22	IBUS1/	E40	ISETHDTAG/

Solder twisted-pair shield lines to adjacent ground pins (e.g. E01 signal line shield to E01G, E02 shield to E02G, etc).

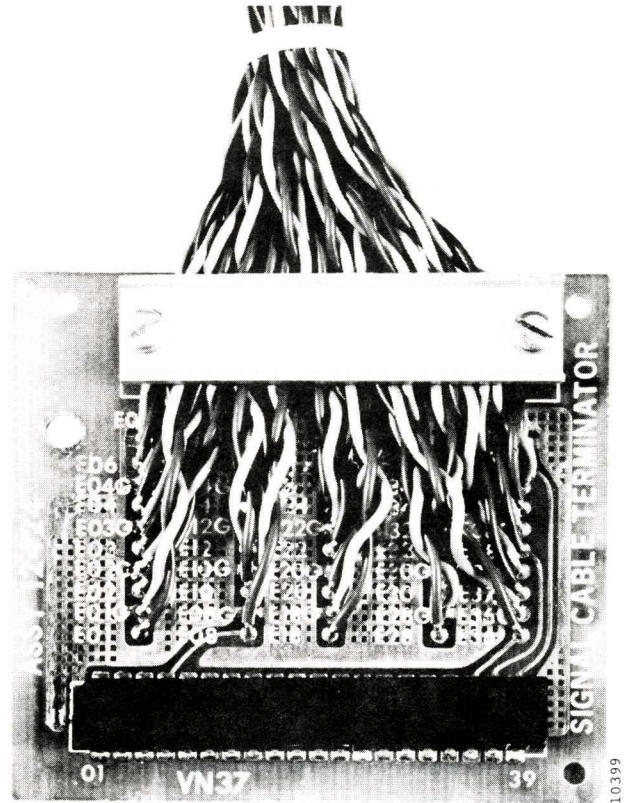

**Figure 3-5. Signal Cable Terminal End Details**

Each signal cable is fabricated from 24 pairs of 95-ohm impedance, twisted-pair lines connected point-to-point between two terminal-end connectors.

All terminal-end connectors for bused signal cables (except the one that mates with the controller Busout connector) should be Signal Cable Terminator Board Assembly VN37, Part No. 12424-001. See Figure 3-5 and Table 3-2 for fabrication details and pin number assignments.

#### Radial Data Cables

Radial data cables make direct, two-way contact between each disk drive and the controller. The same number of radial data cables will be required as there are disk drives in the system. The length of any one radial data cable must not exceed 100 feet.

Each radial cable is fabricated with six pairs of 95-ohm impedance twisted-pair lines plus two 90-ohm TWINAX lines. TWINAX lines are formed as two twisted coaxial lines with a common shield. Connectors for the disk drive end of all radial data cables are the Data Cable Terminator Board Assembly, VN38, Part No. 12433-001. See Figure 3-6 and Table 3-3 for cable end fabrication details and terminator pin number assignments.

A braided copper ground strap (preferably insulated) is normally bundled into each radial data cable at the time of fabrication to be used later for system dc ground strapping. This is optional, however, and the ground straps can be run separately.



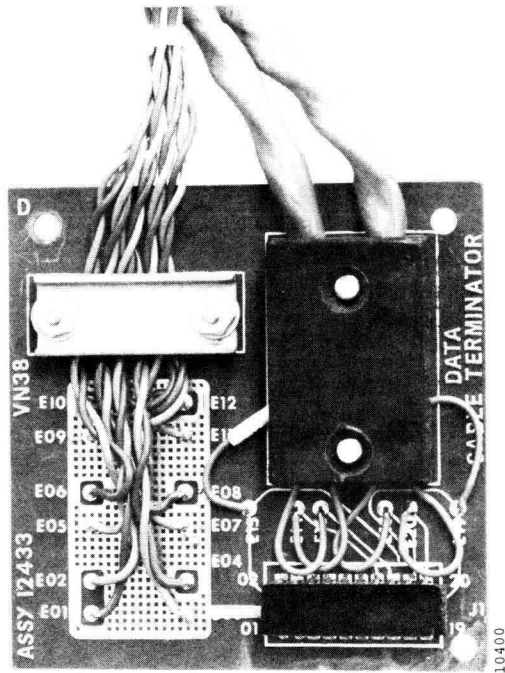

Figure 3-6. Data Cable Terminal End Details

TABLE 3-3. DATA CABLE TERMINATOR VN38 PIN ASSIGNMENTS

Pin No.	Signal (Twisted Pair)	Pin No.	Signal (TWINAX)
E01	CNTRLP5V1		
E02	CNTRLP5V2	E14	IR/WDATAP
E03	E04 SHIELD GND	E15	R/WDATA SHIELD
E04	ICOMPSECIDX/	E16	IR/WDATAM
E05	E06 SHIELD GND		
E06	IATTEN/	E18	IR/WCLOCKP
E07	E08 SHIELD GND	E19	R/W CLOCK SHIELD
E08	ISELECTED/	E20	IR/WCLOCKM
E09	E10 SHIELD GND		
E10	ISEQUENCE/		
E11	E12 SHIELD GND		
E12	ISELECT/		

### SYSTEM INSTALLATION CABLING

The interconnecting cabling for a typical Trident system, with a controller and eight disk drives, is shown in Figure 3-7.

#### Note

Figure 3-7 is applicable to standard, single-access systems only. If the optional, dual-access feature is also being installed, refer to Appendix B for further details and for specific, dual-access cabling procedures.

1. Make sure that the disk drive PWR ON/OFF switch is OFF or that the ac input cable is disconnected from the power source.
2. Connect a bused signal cable between unit Busin connector J03 and Busout connector J02 of the preceding unit (or from the controller bus connector for Drive A). Connectors J02 and J03 are located on the backpanel of the card cage assembly (Figure 3-8).

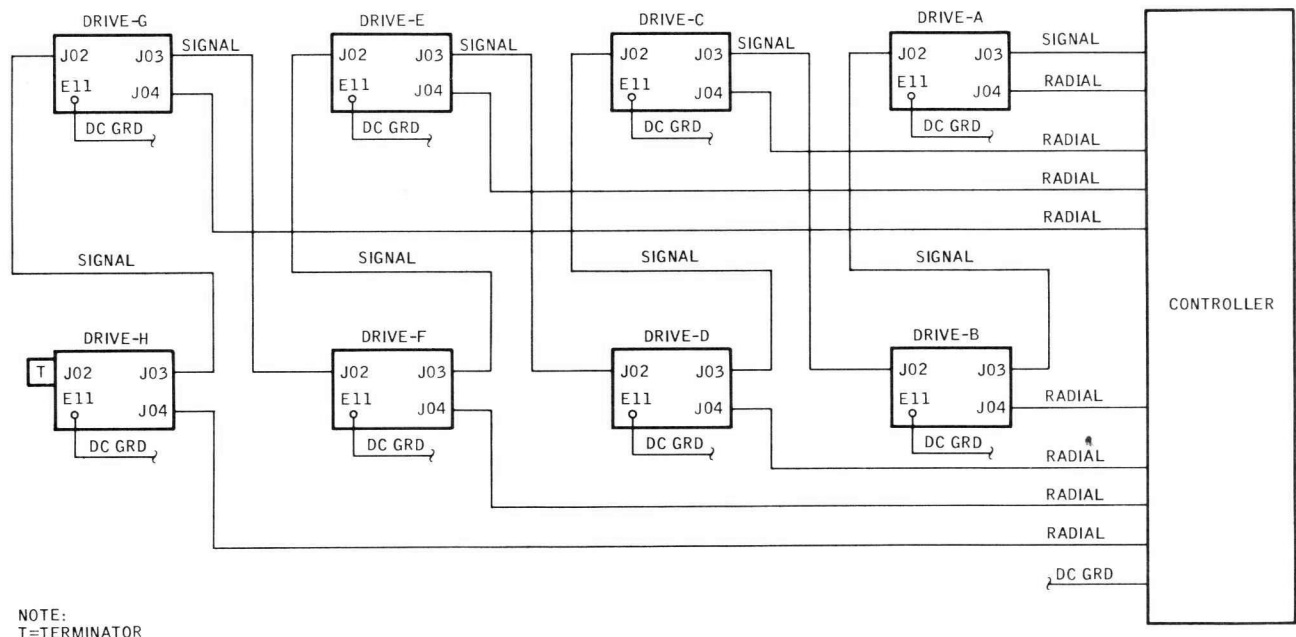

NOTE:  
T=TERMINATOR

Figure 3-7. Trident System Cable Connections

9737A

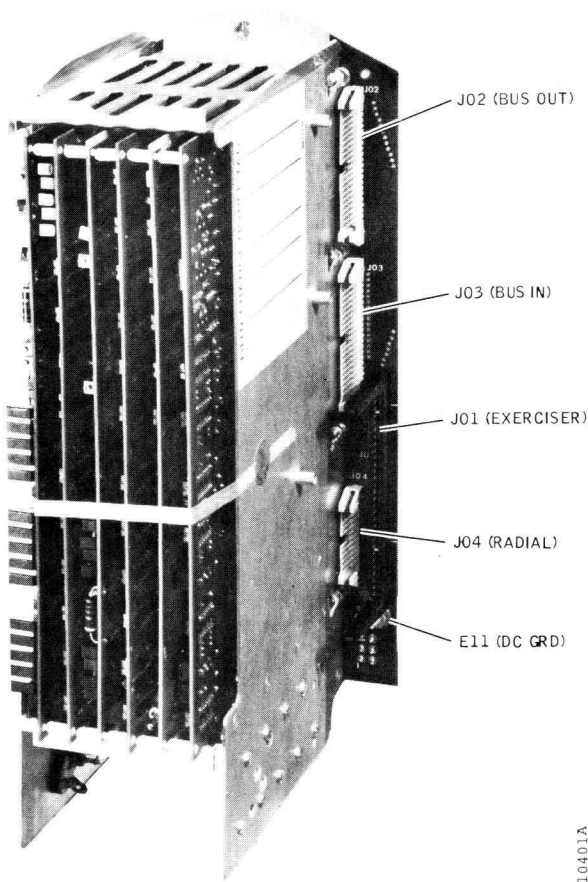

Figure 3-8. Unit Cable Connector Locations

10401A

3. Connect a bused signal cable between unit Busout connector J02 and Busin connector J03 of the following unit. If this drive is the last or only drive in the system, plug a Terminator PWB Assembly, VN56, Part Number 19318-001 into Busout connector J02.
4. Connect a Radial data cable between Radial connector J04 of the unit and the controller radial connector servicing the physical address assigned to the unit.
5. Connect a braided copper dc ground strap (may be bundled with the radial cable or routed separately) from the controller dc ground reference point to GRD terminal E11 on each disk drive card cage assembly.

**Note**

Where installation is not temporary, secure all cable-end terminator boards connected to J02, J03, and J04 with 6-32 screws placed through the boards and screwed into the standoffs. Use flat washers under the screwheads to protect the terminator boards.

6. Perform the Sector Length Selection procedure, which follows, before checking out the unit online.

**SECTOR LENGTH SELECTION**

The byte interval between fixed-length sector markers is selectable over a range of 0 to 4095 bytes per sector (T25 and T50) or 0 to 6142 bytes per sector (T80) by jumpers installed on the Logic III circuit board. These jumpers should be placed during initial installation and may be changed to change the sector length as follows:

**Note**

Current practice is to ship 12 jumper pins in a plastic bag taped to the outside of the card cage assembly for initial sector length selection. Short pieces of bare wire may be substituted if jumper pins are not available.

1. Make sure that the PWR ON/OFF switch is turned OFF.
2. Remove the Logic III circuit board assembly from card cage slot 5A/B, and locate IC sockets 6A and 6B used as jumper connectors. (See Figure 3-9).

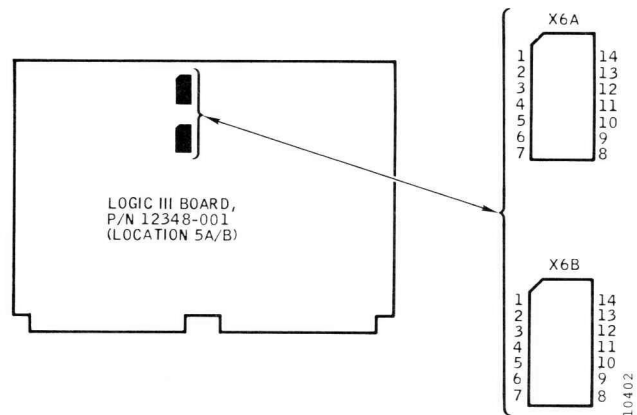

Figure 3-9. Logic III Board Sector Jumpers

3. If fixed-length sectoring is to be disabled, install all 12 jumper pins in sockets 6A and 6B. Refer to Table 3-4 for exact jumper locations.
4. If fixed-length sectoring is to be used on T25 and T50 models, select the total bytes-per-second count (up to a 4095-byte maximum) by installing or removing jumpers from sockets 6A and 6B. Refer to Table 3-4 for the binary weights of each jumper.
5. If fixed-length sectoring is to be used on T80 models, follow this procedure:
  - Divide the total bytes-per-sector count (up to a 6142 byte maximum) by 1.5
  - Convert the total bytes-per-sector count to a binary equivalent. Using the binary weights given in Table 3-4, install or remove jumpers from sockets 6A and 6B to obtain the required value.

**TABLE 3-4. BYTES-PER-SECTOR SELECT JUMPERS**

Binary Weight	Jumper Between These Points
2048	Socket 6B, pins 6 and 9
1024	Socket 6B, pins 5 and 10
512	Socket 6B, pins 4 and 11
256	Socket 6B, pins 3 and 12
128	Socket 6B, pins 2 and 13
64	Socket 6B, pins 1 and 14
32	Socket 6A, pins 7 and 8
16	Socket 6A, pins 6 and 9
8	Socket 6A, pins 5 and 10
4	Socket 6A, pins 4 and 11
2	Socket 6A, pins 3 and 12
1	Socket 6A, pins 2 and 13

• Install jumper for a zero value binary digit.  
 • Remove jumper for a one value binary digit.

- Reinstall the Logic III circuit board in card cage location 5A/B.

**ONLINE OPERATIONAL CHECKOUT**

After system cabling has been completed, each disk drive must be checked out online, first by running available diagnostic routines and then system benchmark programs. Any new or replacement disk drive installed in an existing system should be checked out in like manner.

It is important that the ac and dc grounds be isolated from each other and that the Write Clock Phase Selection procedure be performed on each disk drive installed. These are prerequisites to reliable online system operation.

**Ac-Dc Ground Disconnect**

**Note**

*When a Trident disk drive is checked out as a standalone unit, the ac and dc ground are shorted together at the power supply. In a system, each disk drive dc ground is connected to a common point at the controller.*

After system cabling is completed and before online operation, disconnect the shorting lead on each disk drive power supply circuit board (Figure 3-1) and connect it to the spade terminal marked OPEN.

**Write Clock Phase Selection (T25 and T50 only)**

This selection of write clock phase is done to compensate for delays in write data timing due to differences in cable lengths

between the controller and the various drives. This must be done on each new disk drive when it is first installed in the system or when a disk drive is physically relocated within the system. The T80 drive contains circuits for automatic clock phase selection.

- Make sure that the disk drive ac power cable is connected to the power source; set the PWR ON/OFF switch to ON, and set the INTERFACE/DEGATE switch to INTERFACE.
- Install a scratch pack, and set the START/STOP switch to START. Wait for the device to become ready.
- Select the disk drive being checked, and initiate a continuous write operation via the operating system.
- Connect and adjust an oscilloscope to observe the relationship between NRZDATA at test point 4B35 (connector 4B, pin 35) and the Write Clock at test point 4B26 (T25 and T50).

```

SYNC: INT POS 100ns/cm TRIG
CHAN: 1 dc 2v/cm 4B26 (T25, T50) WRITE CLOCK
CHAN: 2 dc 2v/cm 4B35 NRZDATA
MODE: Alternate; Sync on Chan 1 only.
  
```

- Note, from the oscilloscope display, whether NRZDATA transitions on Channel 2 are occurring during time period A or time period B of the Write Clock cycle, as shown in Figure 3-10 below.

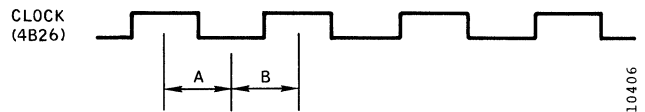

**Figure 3-10. NRZDATA Check**

- Set the START/STOP switch to STOP, wait for the pack to stop, and set the PWR ON/OFF switch to OFF.
- Remove the Data Separator circuit board from card slot 4A/B, and locate jumper IC socket 10B on the board.
- Make sure two jumpers are installed between opposite pins of socket 10B (see Figure 3-11), as indicated below:
  - If NRZDATA transitions noted in step 5 occur during time period A, place jumpers between pins 6 and 9 and between pins 7 and 8.

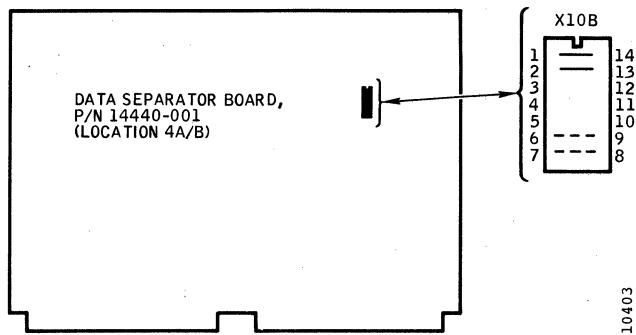

**Figure 3-11. Data Separator Board Write Clock Phasing Jumpers**

- If NRZDATA transitions noted in step 5 occur during time period B, place jumpers between pins 1 and 14 and between pins 2 and 13.
9. Reinstall the Data Separator circuit board in card slot 4A/B.

#### Checkout Procedure

A preformatted disk pack will be required to perform this online checkout procedure; one preferably written by an in-tolerance drive other than the unit being tested. This will ensure read interchangeability between drives. If this is not possible, and the test unit itself must be used to format the pack, first perform a complete head alignment check on the unit, following procedures given in the Maintenance Manual. All heads must be within 250 microinches (T25) or 125 microinches (T50, T80) of track center. Proceed as follows:

1. Recheck the unit installation, making sure of the following:
  - Bused signal cable is properly terminated.
  - Unit dc ground is connected to system ground, and unit ac-to-dc ground jumper is open.
  - Fixed-length sector count has been properly selected.
  - Write clock is properly phased, if applicable, and the INTERFACE/DEGATE switch is set to INTERFACE.
2. Set the PWR ON/OFF switch to ON, install the preformatted disk pack, and set the START/STOP switch to START.
3. When the drive is ready, issue controller commands to select the drive and to check drive ability to detect various Device Check conditions. Each condition should set Device Check and light the DEVICE CHECK indicator on the unit control panel. Clear each Device Check through the controller before proceeding with the test. Each Device Check error is simulated as follows:
  - Activate SET CYLINDER TAG during a seek before READY is active.
  - Activate WRITE during a seek before READY is active.
  - Activate SET HEAD TAG during a seek before READY is active.
  - Set READ/WRITE-READ ONLY switch to READ ONLY, and activate WRITE.
  - Issue an OFFSET command, and activate SET CYLINDER TAG.
  - Present an illegal head address of 408 (T25) or 815 (T50, T80) to the unit, and activate SET CYLINDER TAG.
  - Present an illegal head address of 05 to the unit, and activate SET HEAD TAG.
4. Issue controller commands to perform ten alternate seeks from cylinder 000 to cylinder 001. Verify correct positioning by reading the home address after each seek. When completed, increment the "to" cylinder by one, and repeat the alternate seek cycle (from cylinder 000 to 002). Continue to increment the "to" cylinder by one in this manner until full-stroke alternate seeks from cylinder 000 to cylinder 407 (T25) or cylinder 814 (T50, T80) have been executed.
5. After completing step 4, change the "from" cylinder to 407 (T25) or 814 (T50, T80) and the "to" cylinder to 406 (T25) or 813 (T50, T80), and issue controller commands to perform ten alternate seeks. Verify correct positioning by reading the home address after each seek. When completed, decrement the "to" cylinder by one, and repeat the alternate seek cycle. Continue to decrement the "to" cylinder by one in this manner until full-stroke alternate seeks from cylinder 407 (T25) or 814 (T50, T80) to cylinder 000 have been executed.

6. Set the READ/WRITE-READ ONLY switch to READ/WRITE, and perform a worst-case write and read check on the unit by writing each of the following test data patterns on three inner cylinders and three outer cylinders (all heads). Then read the data and do a bit-by-bit comparison, using all of the offset and strobe timing combinations. The test data patterns are:

- 00000000
- FFFFFFFF
- 0F0F0F0F
- 01010101
- FEFEFEFE
- AAAAAAAD
- 6BD6BD0F
- DADACA58C2FE

7. Perform a crosstalk check of the unit by interlace writing each of the last three test data patterns in step 6 on adjacent cylinders (all heads), repeating the pattern every fourth cylinder, to fill the pack. Read the entire pack and do a bit-by-bit comparison. Then rotate the patterns and repeat the procedure until all three patterns have been written and read on all cylinders.

8. Perform a random read check of the unit by writing the entire pack with any one of the test data patterns given in step 6. Then issue 15,000 seek commands to random addresses, verify each home address, and do a bit-by-bit comparison of data read on each cylinder after each seek.

Successful completion of this online checkout procedure indicates that the disk drive installation is capable of performing to specifications. In the event that a problem is encountered that cannot be resolved, contact the nearest CalComp OEM Support office for assistance. If the unit requires packing for reshipment, refer to the repacking procedures given in Section 2.

## SECTION 4 OPERATION

This section contains descriptions of the operating control and indicator functions, disk pack handling procedures, and disk drive online and offline operating procedures. System operation and maintenance technicians should become familiar with these procedures before operating the disk drive for the first time.

### OPERATING CONTROLS AND INDICATORS

The Trident Disk Drives are designed to be sequenced on and off by the interconnected disk drive controller. However, operating controls are provided to power up and power down the disk drive manually for disk pack changes and for maintenance operation. Indicators are provided to show File Ready and Device Check status. Except for two maintenance switches, the controls and indicators are located on the operator control panel at the front of each disk drive.

### Operator Control Panel

Figure 4-1 shows the four controls and indicators located on the operator control panel, and their functions are described in Table 4-1.

### Maintenance Switches

Figure 4-2 shows the locations of the two maintenance switches not normally required to be used by the operator. A functional description of each is contained in Table 4-1.

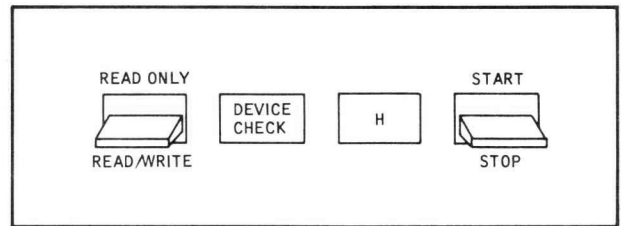

9738

Figure 4-1. Operator Control Panel

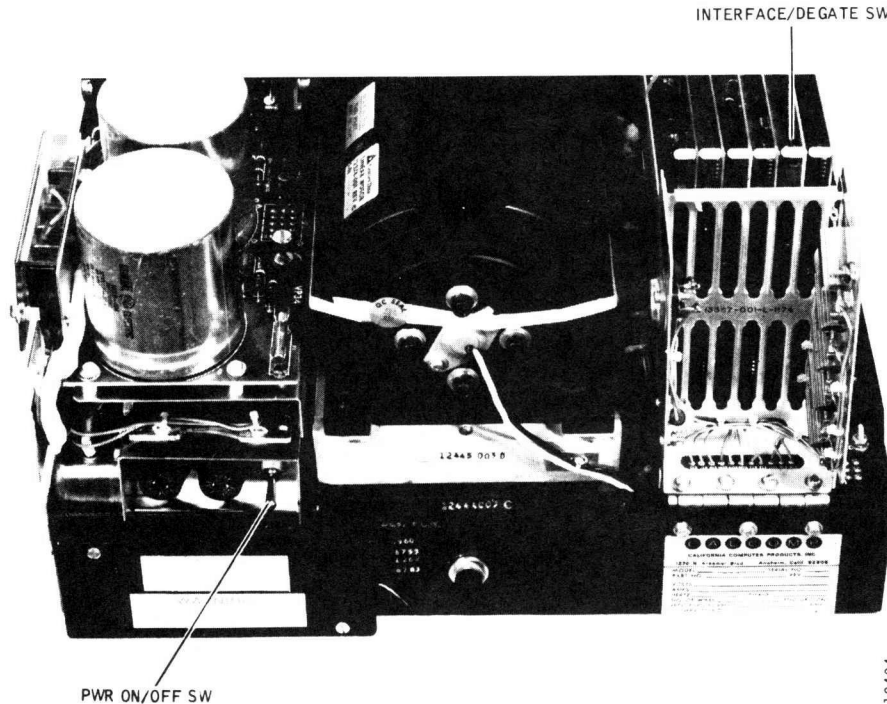

**TABLE 4-1. OPERATING CONTROLS AND INDICATORS**

<p>READ ONLY-READ/WRITE Switch</p> <p>DEVICE CHECK Indicator</p> <p>File Ready Indicator</p> <p>START/STOP Switch</p>	<p>Two-position toggle switch that provides disk pack file protection. READ ONLY position inhibits write commands from writing on pack (an operational Device Check). READ/WRITE position enables both data-read and data-write operations to be performed.</p> <p>Lights when a Device Check error has been detected by the unit and remains lit until the controller resets the Device Check error detector or until the unit is powered down.</p> <p>Indicator with physical address file letter of the drive stamped on the lens. Flashes during power-up and power-down sequencing. The drive is in the Ready condition (powered up and heads loaded) when the indicator stays lit.</p> <p>Two-position toggle switch that permits manual power-up and power-down sequencing. START position turns on the spindle drive motor, initiates a brush cycle, and loads the heads. (Heads will not load and a seek incomplete will result if a disk pack is not installed or an unsafe condition exists.) The STOP position retracts the heads, turns off the spindle drive motor, and activates the dynamic brake to stop the disk pack.</p>
<p>Maintenance Switches (See Figure 4-2)</p> <p>PWR ON/OFF Switch</p> <p>INTERFACE/DEGATE Switch</p>	<p>Two-position toggle switch that controls ac power to the disk drive dc power supply. This switch should be set to OFF before removing any circuit board or when replacing disk drive assemblies or components.</p> <p style="text-align: center;"><b>WARNING</b></p> <p style="text-align: center;"><i>Ac power is still present at Ac Input Control Assembly when this switch is OFF and poses a shock hazard if the terminal board cover is removed.</i></p> <p>Two-position toggle switch located on the top edge of the Logic I card. (The switch is accessible only when the rear cover is off.)</p> <p>The INTERFACE position enables normal, online operation, permitting the disk drive to be selected by the controller. The DEGATE position disconnects the disk drive from the controller and enables T2000A Exerciser inputs for offline maintenance operation of the drive.</p>

**DISK PACK HANDLING**

Trident disk packs are shipped in reusable corrugated shipping containers that are lined with polyurethane foam. The entire container, including the disk pack, can be handled

by one person and provides adequate storage protection with no degradation of performance. Disk packs in their original shipping containers should be stacked no more than eight high while in storage.

Disk packs in library use should always be kept in their plastic cases, unless mounted in a disk drive. The case of a disk pack consists of a clear plastic top cover with a handle and a bottom cover. Where possible, the disk packs should be stored in the same room environment as the disk drive or should be brought into the same room no less than 2 hours before use.

### Installing a Disk Pack

To install a disk pack on this disk drive, proceed as follows:

1. Make sure that the disk drive START/STOP switch is set to STOP and that the green File Ready indicator is out.
2. Unlatch the air shroud lid of the disk drive and open the lid. The lid latch is located beneath the front edge overhang at the center.
3. Check the interior of the air shroud. The interior should be clean, and the heads and brushes should be completely retracted from the disk pack area.
4. Remove the lower cover from the disk pack and lower the top cover with the disk pack carefully onto the disk drive spindle.
5. Press down the top cover handle to engage the spindle-locking mechanism; rotate the handle clockwise to lock the disk pack to the spindle and to disengage the top cover.
6. Carefully lift and remove the top cover from the disk drive and close the air shroud lid. Make sure that the lid latch locks.
7. If the installed disk pack is a permanent record or is a head alignment pack, set the READ ONLY – READ/WRITE switch to READ ONLY to protect the pack from being written on. If writing is to be permitted, set this switch to READ/WRITE.
8. Store the top and bottom covers of the disk pack together to minimize dust accumulation inside the case.

### Removing a Disk Pack

To remove a disk pack from this disk drive, proceed as follows:

1. Power down the disk drive, if applicable, by setting the START/STOP switch to STOP. The green File Ready indicator should start flashing.

2. Wait until the File Ready indicator stops flashing (about 20 seconds), unlatch the disk drive air shroud lid, and open the lid.
3. Separate the top and bottom covers of the disk pack, and lower the top cover carefully over the disk pack by the handle.
4. Press down the top cover handle to engage the spindle-locking mechanism; rotate the handle counter-clockwise to unlock the disk pack from the spindle and to reengage the top cover.
5. Lift the top cover and disk pack carefully from the disk drive and close the air shroud lid.
6. Replace the bottom cover on the disk pack and return the pack to storage.

### DISK DRIVE OPERATION

The disk drive, with disk pack installed, is normally operated online by the disk drive controller. Unless otherwise noted, the disk drive PWR ON/OFF switch should be left ON, and the INTERFACE/DEGATE maintenance switch must be in the INTERFACE position.

#### Disk Drive Power-Up

To put the disk drive in the drive-ready condition for normal system operation, proceed as follows:

1. Recheck that a disk pack has been installed, that the air shroud lid is latched closed, and that the READ ONLY-READ/WRITE switch is set correctly for file protection (READ ONLY) or to allow pack writing (READ/WRITE).
2. Set the disk drive START/STOP switch to START. The spindle drive motor should be heard to start and increase in speed, and the green File Ready indicator should start flashing.
3. After about 20 seconds, the green File Ready indicator should stop flashing and remain lit. The red DEVICE CHECK indicator should be out.

#### Note

*If the File Ready indicator continues to flash, the first seek operation has not been completed. Set the START/STOP switch to STOP, wait for the spindle to stop, and attempt a restart by repeating Step 2.*



If step 3 indications are normal, the disk drive is ready for online operation under control of the disk drive controller. No further operator intervention is required unless:

- A disk pack change is requested.
- The red DEVICE CHECK indicator comes on, indicating that a malfunction has occurred.

### Disk Drive Power-Down

The operator can initiate a power-down sequence to turn off the disk drive by setting the START/STOP switch to STOP. The green File Ready indicator will start flashing and continue to flash until the disk pack has come to a stop. Power-down sequencing is completed in about 20 seconds, after which the File Ready indicator will go out.

### Clearing a Device Check

Most Device Check errors will be cleared by the operating system through the controller when the disk drive is online. However, if the disk drive is being operated offline, or the red DEVICE CHECK indicator lights when operating online, operator intervention is required. Proceed as follows:

1. Power down the disk drive by setting the START/STOP switch to STOP. Wait for the green File Ready indicator to stop flashing, and then power up the disk drive by setting the START/STOP to START.
2. If the red DEVICE CHECK indicator lights again after power-down and power-up sequencing, an equipment malfunction is indicated and maintenance action is required.

#### Note

*Some Device Check conditions can also be cleared by initiating a Rezero or a Device Check Reset command through the controller or exerciser.*

### Offline Operation

Procedures that follow are for offline operation of the disk drive by maintenance technicians only and should be disregarded by system operators.

To take the disk drive offline to the operating system, proceed as follows:

1. Remove the rear cover from the disk drive, and set the INTERFACE/DEGATE switch to DEGATE. (See Section 2 for the cover removal procedure.) The drive is now offline.

2. If a T2000A Exerciser is to be used, connect the exerciser cable between the exerciser and card cage connector J01 on the disk drive. All exerciser toggle switches should be off (down).

#### Note

*Steps 1 and 2 can both be performed while the disk drive is powered up. However, a pack change is usually performed prior to maintenance to protect the pack, requiring power-down sequencing before or after the drive is taken offline.*

3. Install a scratch pack or the CE Head Alignment pack, as applicable, and set the READ ONLY-READ/WRITE switch to the appropriate position.
4. Set the disk drive START/STOP switch to START. The spindle drive motor should be heard to start and increase in speed, and the green File Ready indicator should start flashing.
5. After about 20 seconds, the green File Ready indicator should stop flashing and remain lit. The red DEVICE CHECK indicator should be out.

The unit is now in the Drive Ready condition and offline. Disk drive checkout can now proceed, using the exerciser for control. Device check errors can be cleared through the exerciser or by power-down, power-up sequencing, as described previously. To power down while offline, set the START/STOP switch to STOP.

#### CAUTION

*Printed circuit boards and all other components should be removed and replaced only when the PWR ON/OFF switch is OFF. Further, this switch should be turned ON or OFF only while the disk drive is offline to an operating system (DEGATE active). This prevents power transients from reaching the drive interface lines.*

### Returning the Disk Drive Online

After disk drive offline checkout or repair, the disk drive can be returned to the operating system as follows:

1. Make sure that the PWR ON/OFF switch is ON.
2. Set the INTERFACE/DEGATE switch to INTERFACE. The disk drive is now online to the system.
3. Disconnect the exerciser cable from the disk drive connector, if applicable.

#### Note

*Steps 1 thru 3 can be performed while the disk drive is powered-up. However, a pack change is usually necessary after maintenance to ready the drive for operation. Refer to the Disk Drive Start-Up Online procedure.*

**APPENDIX A**  
**TRIDENT STAND KIT ASSEMBLY**

The Trident lowboy stand (Part No. 19038-001) is an optional accessory specially designed for desktop models of Trident Disk Drives. The stand is shipped in kit form and consists of a package of disassembled, flat, frame and panel members with assembly hardware. This appendix contains complete, illustrated assembly instructions for the kit. Assembly time is approximately 1 hour.

**ASSEMBLY PROCEDURE**

1. Carefully unpack all kit parts and check them against the items and quantities listed in Table A-1 for

shortages. Refer to the assembly illustrations for parts identification, if necessary. Retain the corrugated cardboard container.

**Note**

*The numbers appearing parentheses in the steps that follow are item identification numbers used for part referencing in both the Kit Parts List and in the assembly illustrations.*

**TABLE A-1. KIT PARTS LIST**

Item No.	Quantity	Part Name	Part No.
1	1	Frame Base	19028-xx1
2	1	Frame Top	19029-xx1
3	1	Left Side Panel	19030-xx1
4	1	Right Side Panel	10930-xx2
5	1	Rear Panel	19032-xx1
6	1	Front Door	19033-xx1
7	2	Rear Panel Catch	19034-xx1
8	2	Door Hinge Bracket	19035-xx1
11	42"	Rub Strip	13867-001
12	1	Flush Latch Assembly	11493-001
13	42	#10 x 9/16" Pan Head Machine Screw	90448-045
14	38	#10 Split Lockwasher	90489-005
15	38	#10 Flat Washer	90488-006
16	2	Magnetic Catch	17203-001
17	2	Magnetic Striker Plate	17024-001
18	2	#10 Hex Nut	90487-006
19	3	3/8" - 16 x 5/8" Pan Head Machine Screw	90483-026
20	3	3/8" Split Lockwasher	90489-008
21	3	3/8" Flat Washer	90488-009
22	4	Swivel Caster	18522-001
23	4	Cushioned Leveler	92025-060
24	2	Mounting Strip	19031-001
25	72"	Foam Tape	90548-009

2. Lay the corrugated cardboard packing material on the floor for use as an assembly surface to protect the finished surfaces of the panels from being marred. Place the Left Side Panel (3) flat on its finished surface, and assemble the Frame Base (1) to it by using eight #10 x 9/16" pan head screws (13), #10 split lockwashers (14), and #10 flat washers (15), as shown in Figure A-1.
3. Place the Frame Top (2), oriented as shown in Figure A-2, into position, and assemble it to the Left Side Panel, using eight #10 x 9/16" pan head screws, split lockwashers, and flat washers (13, 14, 15), as in the preceding step.
4. Cut lengths of plastic rub strip (11), as required, and install them over the frame edges shown in Figure A-2.

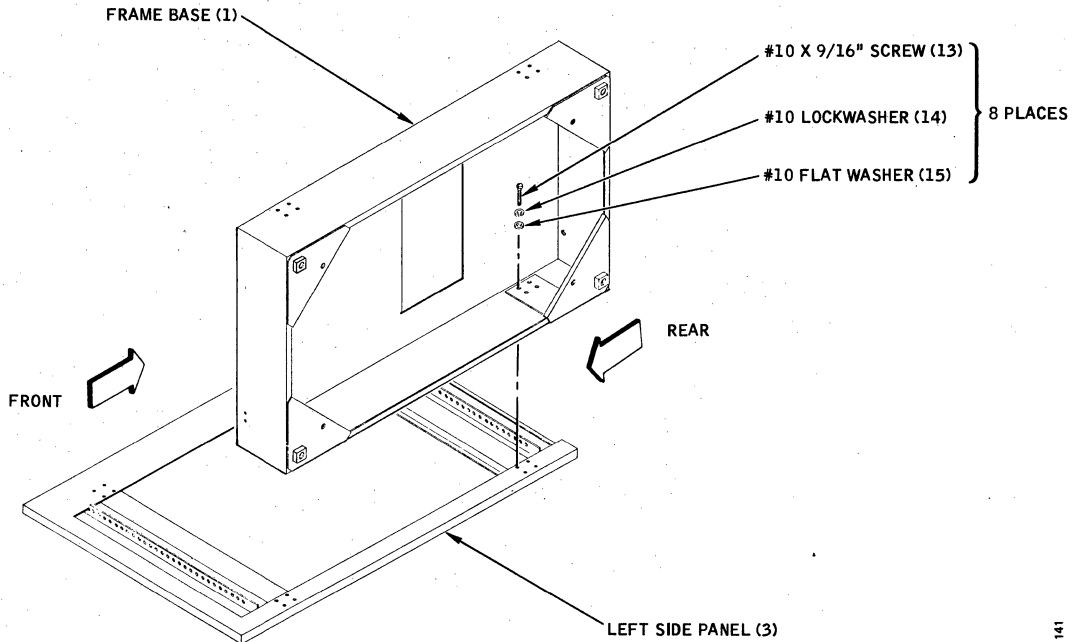

Figure A-1. Stand Assembly, Step 2

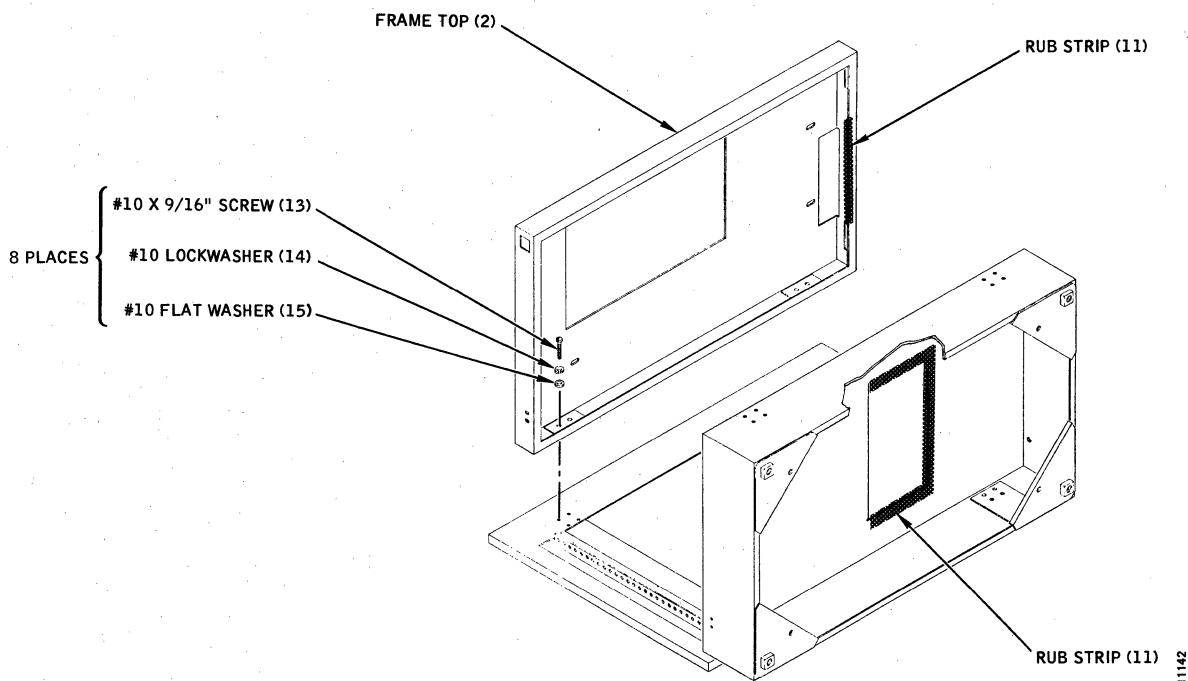

Figure A-2. Stand Assembly, Steps 3 and 4

5. Turn the assembled parts over so that the Left Side Panel is facing up, and set it aside. Place the Right Side Panel (4) flat on its finished surface, and set the assembly down over it, as shown in Figure A-3. Use sixteen #10 x 9/16" pan head screws, split lockwashers (13, 14, 15) to assemble the Right Side Panel to the assembly, top and bottom.
6. Check all parts assembled thus far for squareness,

and realign them as necessary. Tighten all mounting hardware.

7. Install four Swivel Casters (22) and four Cushioned Levelers (23) to the Frame Bottom member of the assembly, as shown in Figure A-4. Screw the levelers in far enough so that they will clear the floor by about 1/4 inch, and set the assembly upright upon its casters.

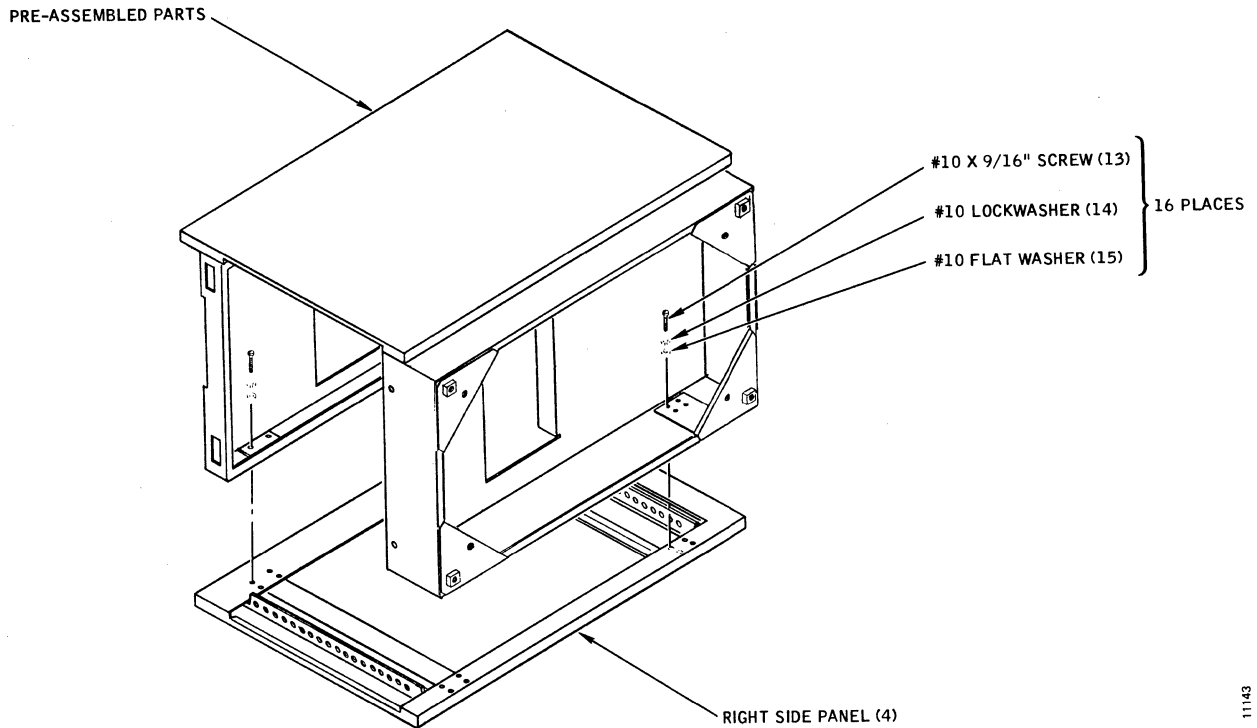

Figure A-3. Stand Assembly, Steps 5 and 6

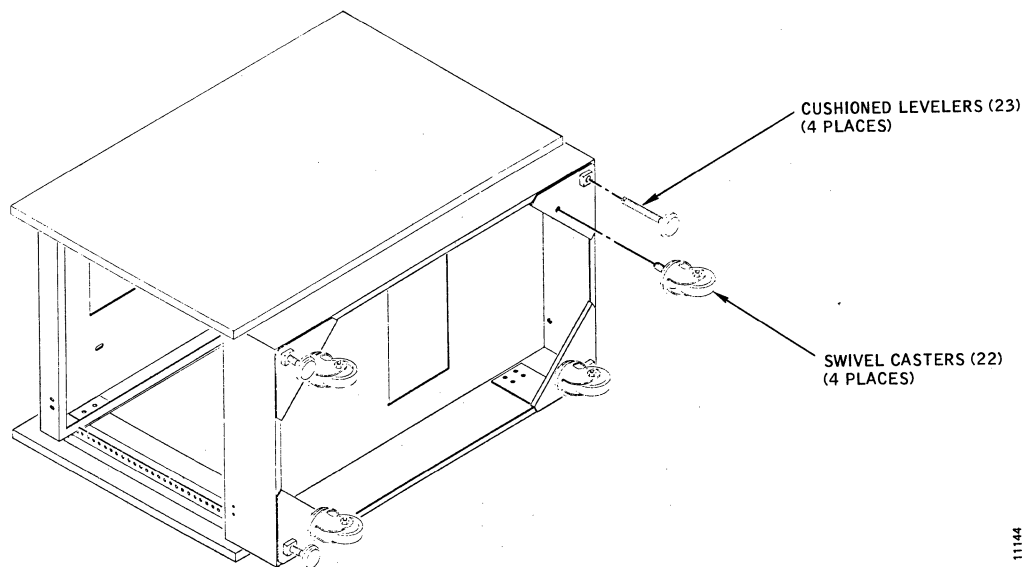

Figure A-4. Stand Assembly, Step 7

11143

11144

8. Install two Rear Panel Catches (7) to the Frame Base member of the assembly, as shown in Figure A-5, using two #10 x 9/16" pan head screws, split lockwashers, and flat washers (13, 14, 15).
9. Install two snap-in, Magnetic Catches (16) into the two slots in the Frame Top member of the assembly, as shown in Figure A-5.
10. Install two Mounting Strips (24), one each to the rear of the fixed frame members on the right and left sides, as shown in Figure A-5. Use two #10 x 9/16" pan head screws passing thru the third hole from the bottom of the fixed frame member into the bottom hole of the mounting strip, as shown in the figure.
11. Lay the Rear Panel (5) face down on its finished surface, and apply two lengths of adhesive-backed Foam Tape (25) to the top and bottom inner edges of the panel, as shown in Figure A-6. Remove the backing from the tape to expose the adhesive surface.
12. Install the two Magnetic Striker Plates (17) on the Rear Panel, as shown in Figure A-6. These plates also have adhesive surfaces.
13. Engage the two bottom slots in the completed Rear Panel into the two Rear Panel Catches already installed on the assembly, and swing the top of the panel upward until the two magnetic catches engage. Check the alignment of the panel to the frame assembly, and adjust the catches, if necessary, for proper panel fit.
14. Install the two Door Hinge Brackets (8) on the front of the assembly, as shown in Figure A-7. The bottom hinge bracket is secured with two #10 x 9/16" pan head screws, split lockwashers, and flat washers (13, 14, 15). The top hinge bracket requires two #10 nuts for installation. Assemble the top hinge bracket to the frame by installing it as shown in the figure with its mounting hardware.

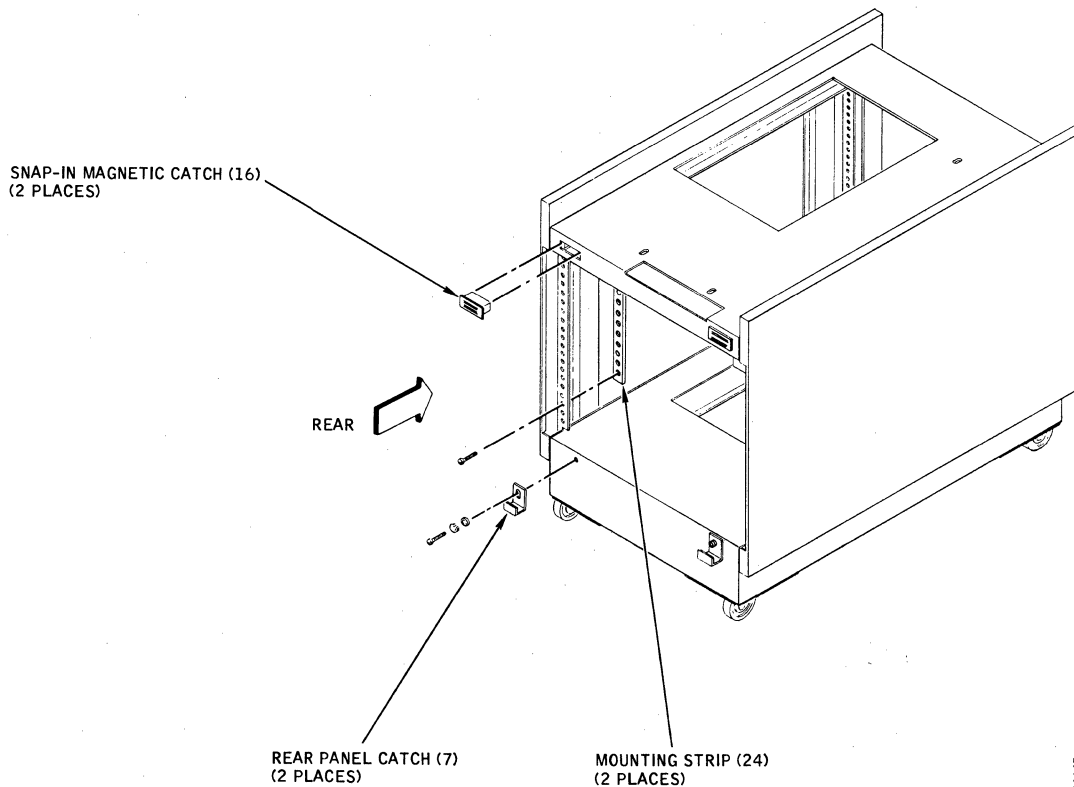
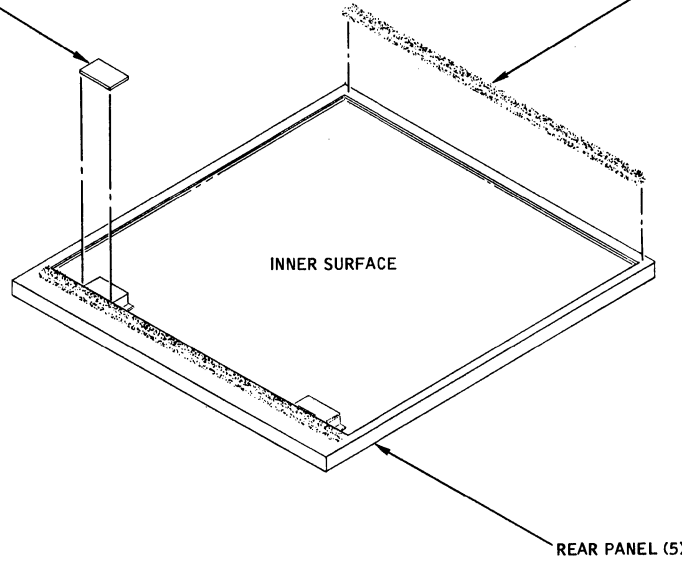

Figure A-5. Stand Assembly, Steps 8 thru 10

MAGNETIC STRIKER PLATE (17)  
(2 PLACES)

FOAM TAPE (25)  
(2 PLACES)



11146

Figure A-6. Stand Assembly, Steps 11 and 12

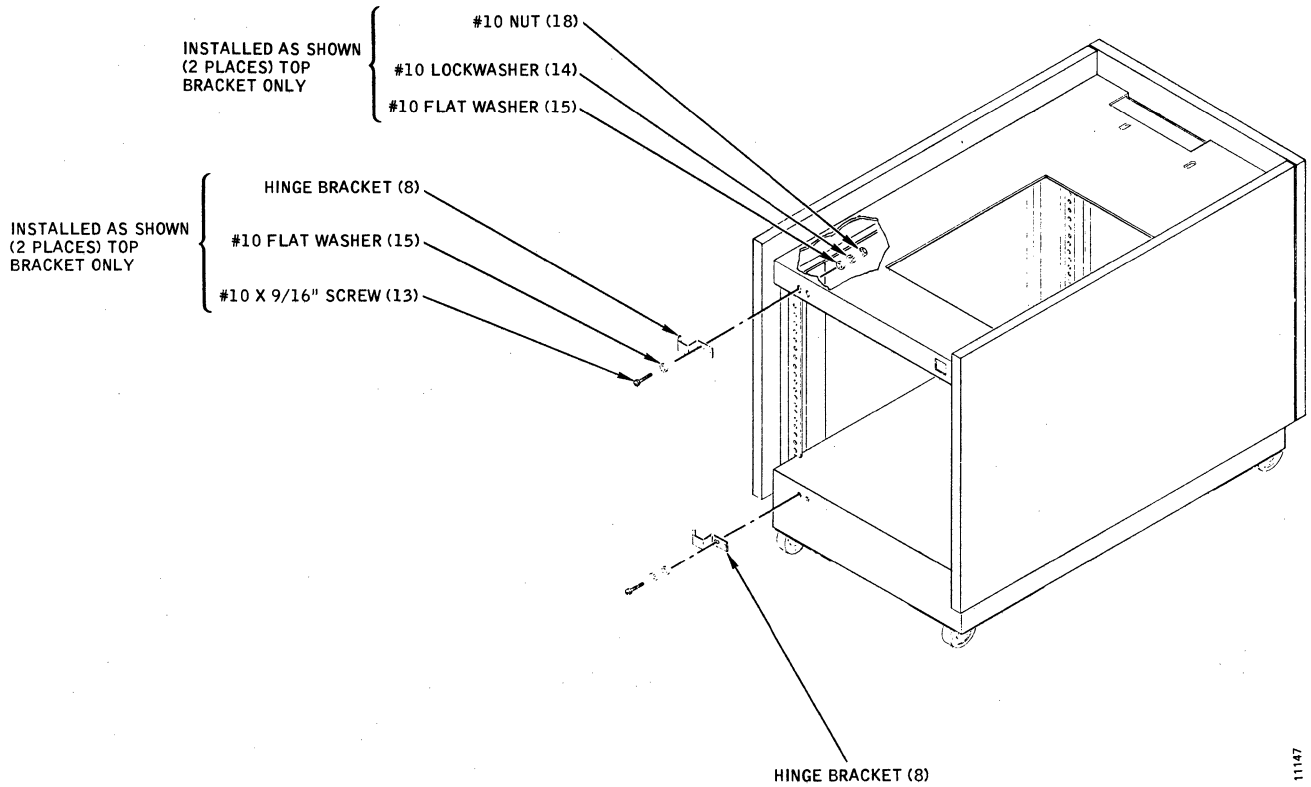

11147

Figure A-7. Stand Assembly, Step 14

15. Lay the Front Door (6) down on its finished surface, and apply two lengths of adhesive-backed Foam Tape (25) to the top and bottom inner edges of the door, as shown in Figure A-8.

16. Install the Flush Latch Assembly (12) into the rectangular cutout in the Front Door. To do this, refer to Figure A-8, and proceed as follows:

- Group the latch, spring, and cradle as shown in the figure; hold them in one hand.
- Insert the tail end of the latch through the lower part of the panel cutout.
- Arch the top end of the latch into the upper part of the cutout (arrow #1 in the figure), and then push upward.
- Press the top of the latch firmly with your index finger, and snap the cradle into the cutout and even with the surface of the door with your thumb (arrow #2 in the figure).

17. Hang the front door assembly onto the main assembly by engaging its formed hinge slots over the hinge pins on the two, door hinge brackets. See Figure A-9. Swing the door closed, and check to see that the latch engages properly and that the door hangs square and flush with the two side panels. If not, adjust the two, door hinge brackets as necessary.

18. Install plastic Rub Strip (11) around the exposed edges of the rear cutout in the frame top member, as shown in Figure A-9. Stand assembly is now complete.

### MOUNTING THE TRIDENT DISK DRIVE

The hardware remaining after the Trident Stand Kit has been completely assembled is for mounting the Trident Disk Drive on the stand. To mount the drive on the stand, refer to Figure A10 and proceed as follows:

1. Remove both the front door and the rear panel from the stand and store them safely away.

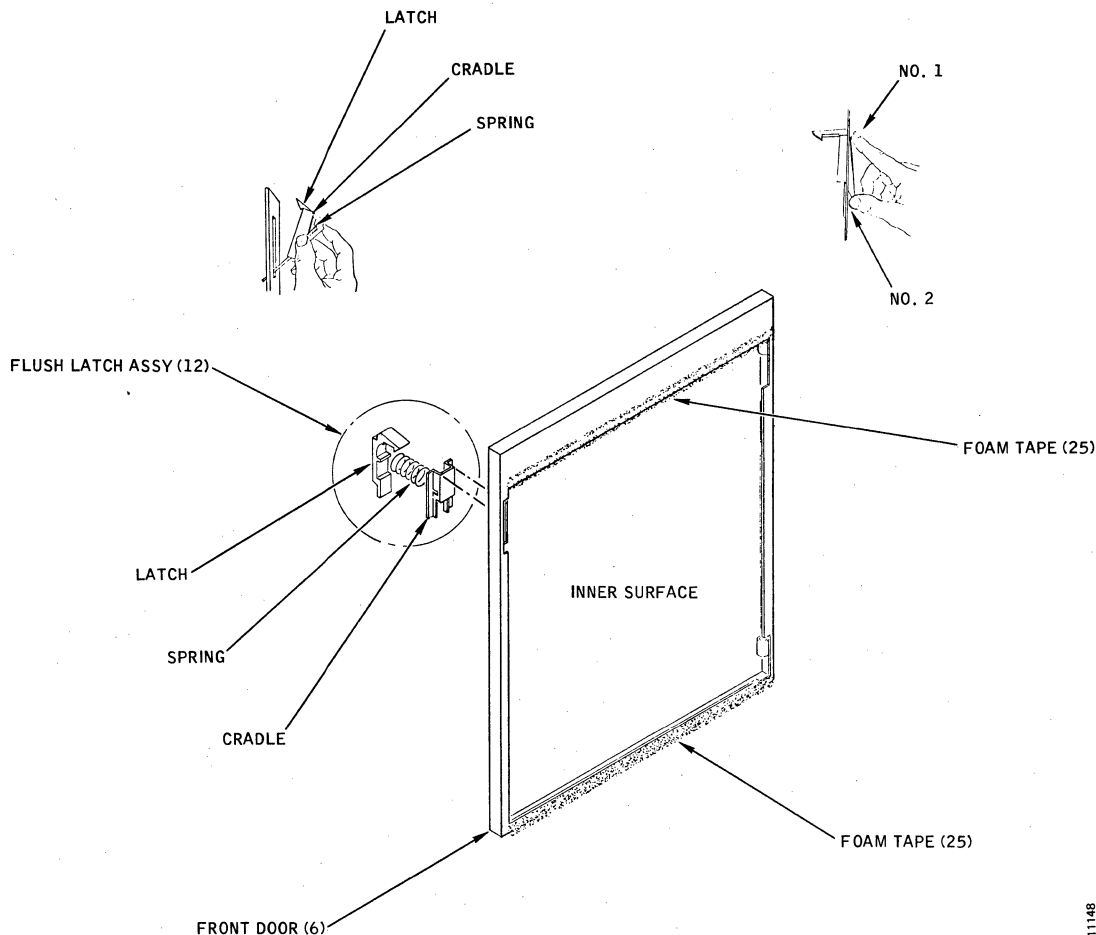

Figure A-8. Stand Assembly, Steps 15 and 16

11148

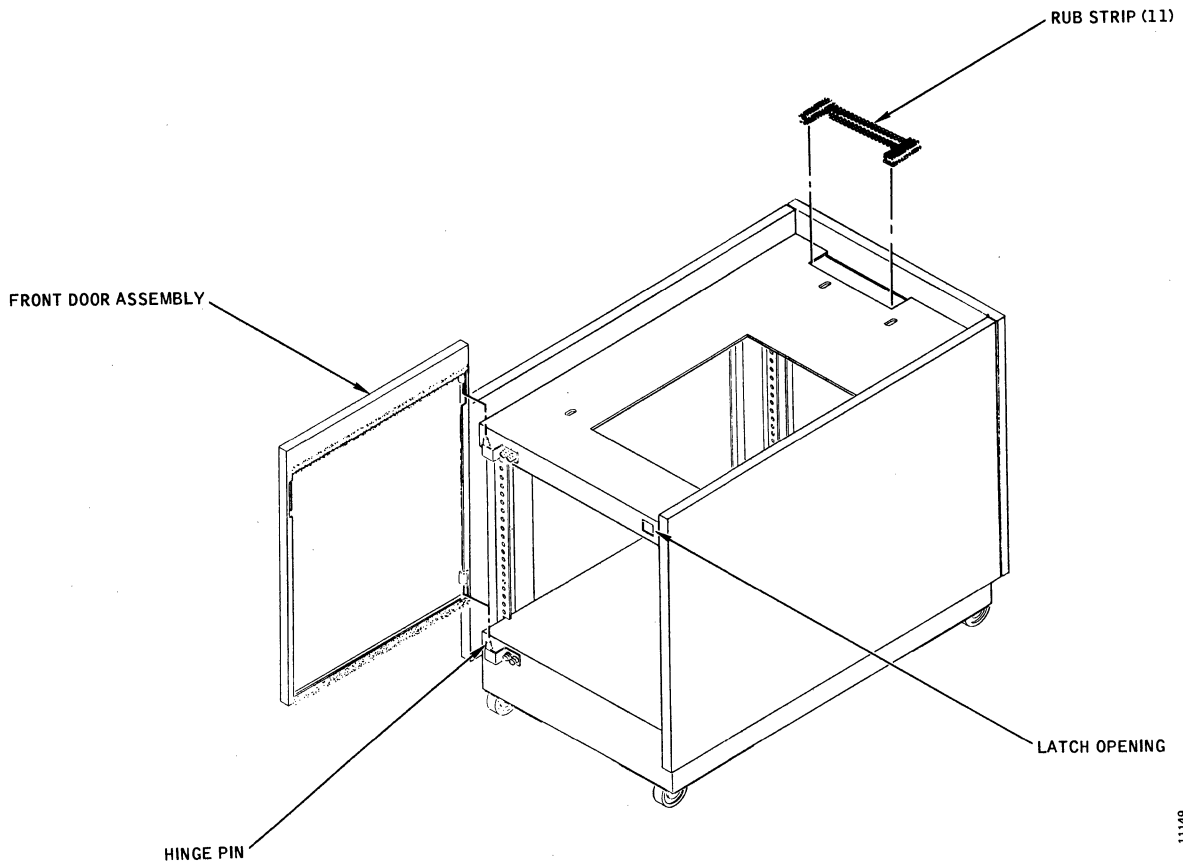

Figure A-9. Stand Assembly, Steps 17 and 18

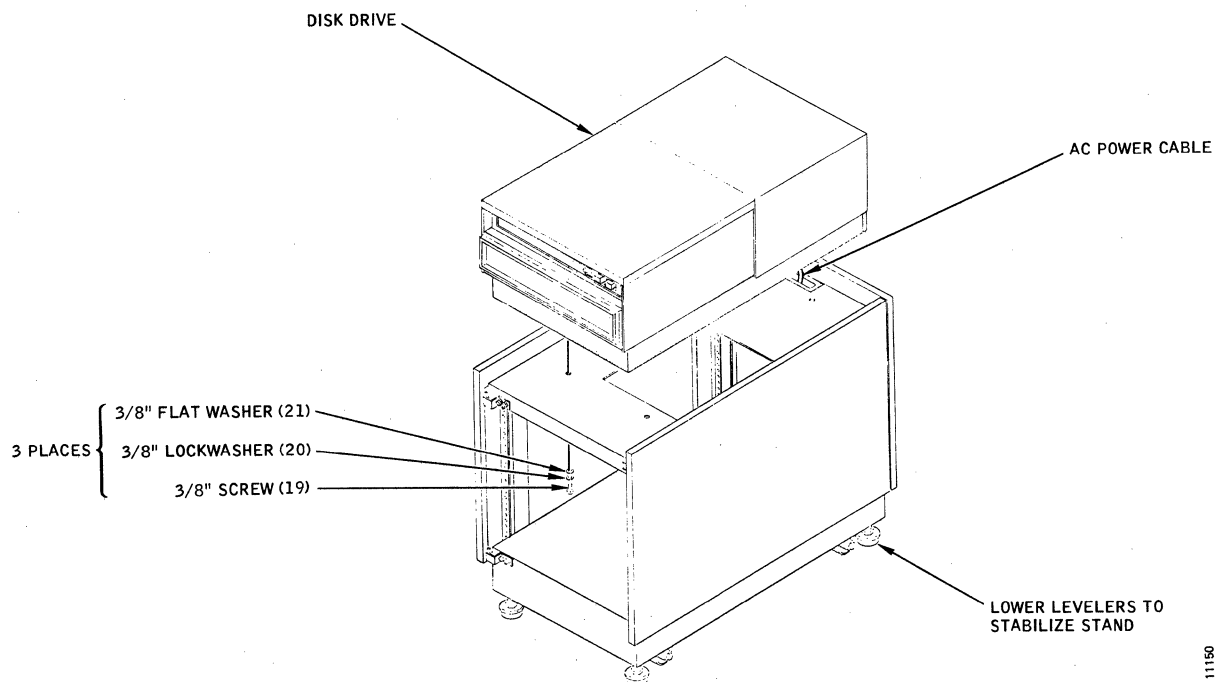

Figure A-10. Drive-Stand Mounting



2. Lower the four levelers by screwing them down firmly against the floor to stabilize the stand and to keep it from rolling.
3. Lift the Trident Disk Drive carefully (three-man job) and lower it gently onto the stand; take care not to smash anyone's fingers between the drive and the stand. Feed the drive ac power cable down through the rear cutout of the stand frame top member.
4. Slide the drive to align its three bottom mounting holes with the three slots in the stand frame top member, and secure the drive to the stand with the three 3/8-16 x 5/8" pan head screws (19), 3/8" split lockwashers (20), and 3/8" flat washers (21).
5. Raise the stand levelers, move the stand and drive combination into its final installation position, and lower the levelers to stabilize and to level the stand. Route all interconnecting cables up from the bottom of the stand through the rub-strip-protected cutout in the frame base and the rear cutout in the frame top. The large cutout in the center of the frame top member is for maintenance access only.
6. After the installation has been completed, reinstall the rear cover and the front door.

## APPENDIX B

### DUAL-ACCESS ASSEMBLY

The Trident Dual-Access Kit (Part No. 17682-001) provides a dual-access interface for a single T50 or T80 Disk Drive. The standard interface for these drives permits interconnection and access to only one control unit. With Trident Dual-Access Kits installed (one per disk drive), a time-shared system of disk drives, accessible to either of two control units is possible.

Each kit contains a dual-access chassis assembly, two rack mount slides, a front panel, and assorted mounting hardware for mounting the dual-access unit inside the standard Trident Lowboy Stand immediately below the Trident Disk Drive to which it connects. New disk drive interconnecting cables, which are ordered and shipped separately from the kit, are needed to make the installation.

#### Note

*All dc power necessary to operate the Dual-Access Assembly is taken from the Trident Disk Drive with the exception of logical +5 volts. An external, fully regulated 5-volt power supply with an output current capacity of at least 2.5 amperes is required for each assembly.*

This appendix contains assembly installation and operating instructions for the Dual-Access Kit within a lowboy stand. Rack mounting procedures would be nearly identical. Installation time, disregarding fabrication time for special cables, is under 1 hour.

#### PHYSICAL INSTALLATION

1. Carefully unpack all parts and check them for shortages against items and quantities listed in Table B-1. Refer to Figure B-1 for parts identification and installation configuration.

#### Note

*Numbers in parentheses in the following steps are used for item identification in both the parts list and in the installation drawing.*

2. If you are installing the assembly in a Trident stand, make sure that the stand is made stable by lowering all levelers firmly against the floor. Remove both the

front door and rear cover from the stand, and store them until installation is completed.

**TABLE B-1. DUAL ACCESS KIT PARTS LIST**

Item No.	Quantity	Part Name	Part No.
1	1	LH Extension Slide	19273-001
2	1	RH Extension Slide	19273-002
3	2	Slide Mount Bracket	19292-001
4	4	Bar Nut	19326-001
5	1	Dual-Access Chassis Assembly	17683-001
6	1	Front Panel	17755-121
7	4	Strain-Relief Bar	17724-001
8	16	8-32 Short Screw	90448-032
9	4	8-32 Long Screw	90448-045
10	28	No. 8 Split Washer	90489-004
11	8	No. 8 Flat Washer	90488-005
12	8	8-32 Hex Nut	90487-005

3. Disconnect and remove all cables leading to and from the disk drive. The ac power cable should also be disconnected from the power source, and the rear cover should be removed from the disk drive.
4. Install RH and LH Extension Slides (1 and 2) on the front and rear mounting rails of the Trident stand. See Figure B-1 for details. Note that two slide mount brackets (3) are required at the rear of the slides and that all slide mount brackets are installed with bar nuts (4) behind the rails.
5. Extend the members of both slides fully forward, and mount the dual-access chassis assembly (5) by tipping the two front tangs on the chassis assembly into the cutouts at the ends of the slide members. After engaging the two tangs, lower the rear end of the chassis to fit over the two pins on the slide members. See Figure B-1, View B.

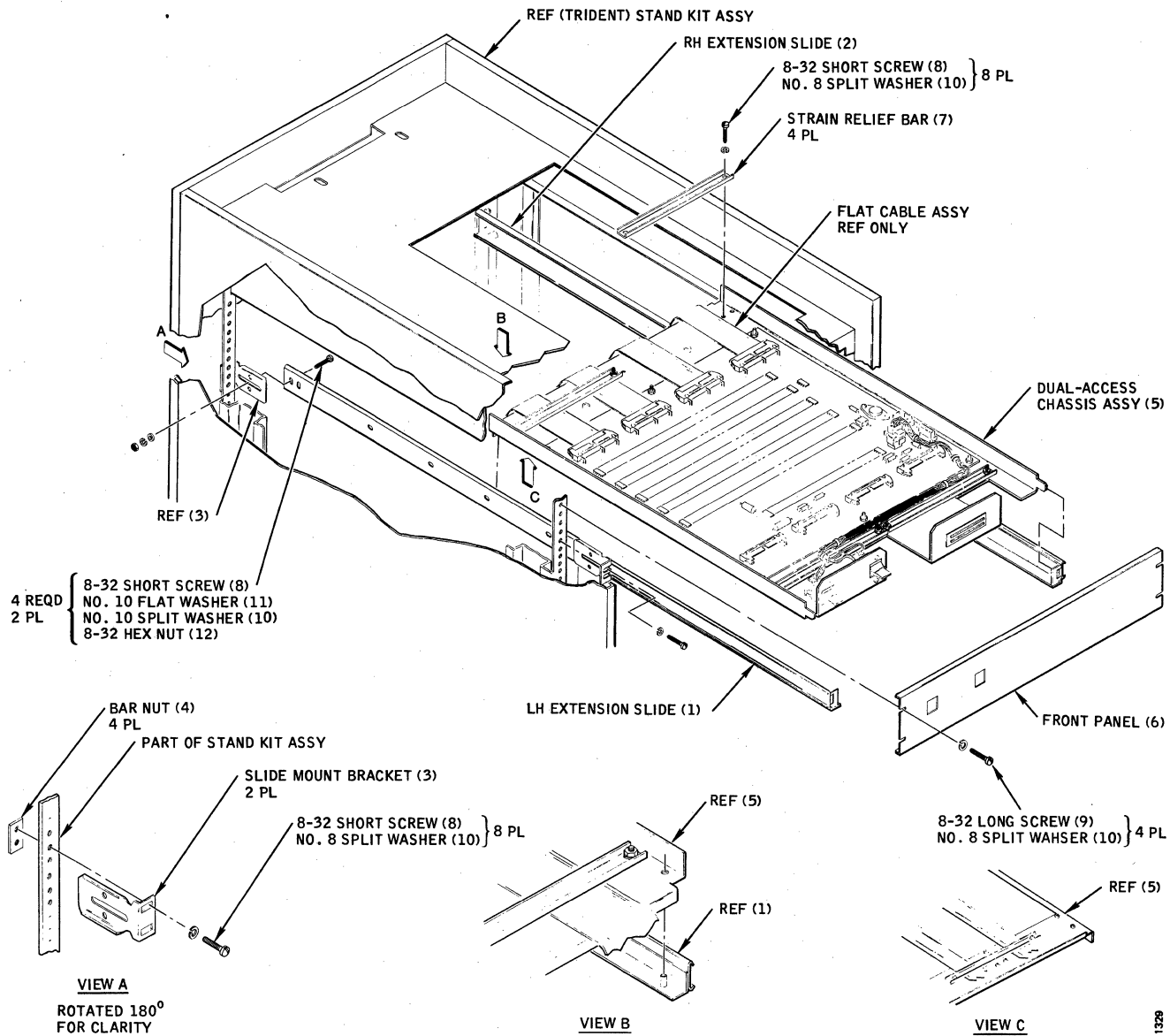

Figure B-1. Dual-Access Assembly Kit Installation

6. Proceed to cable up the system. After all interconnecting cabling has been installed and clamped with strain-relief bars, mount the front panel (6) on the chassis assembly by slipping the two cutouts in the panel over the two switches and allowing the panel to be caught by the magnetic latch on the chassis assembly.
7. To complete the physical installation, slide the chassis assembly rearward to the closed position, align the front panel (four slots with railing holes), and secure the panel to the front mounting rails of the stand with four screws and split washers from the kit.

**UNIT AND SYSTEM CABLING**

1. Raise the disk drive card cage assembly to its open position, locate the 4B card connector (bottom connector for the card in slot no. 4), and remove any

plastic sleeve insulators that might be on wirewrap pins 31 thru 60 of the connector.

2. Connect plug P44 of a Dc Power Cable (Part No. 17759-001) over 4B connector wirewrap pins 31 thru 60. Be sure to mate the P44 plug pin marked "32" to pin 32 of the card connector. Dress the free end of the cable to emerge at the rear — through the cutout next to the outboard hinge of the card cage assembly. Then close and latch the card cage assembly.

**Note**

Refer to Figure B-2 while making cable connections to the disk drive unit. Route all such cables through the top rear cutout of the Trident stand, underneath the extended dual-access assembly, and up and over to the front connectors.

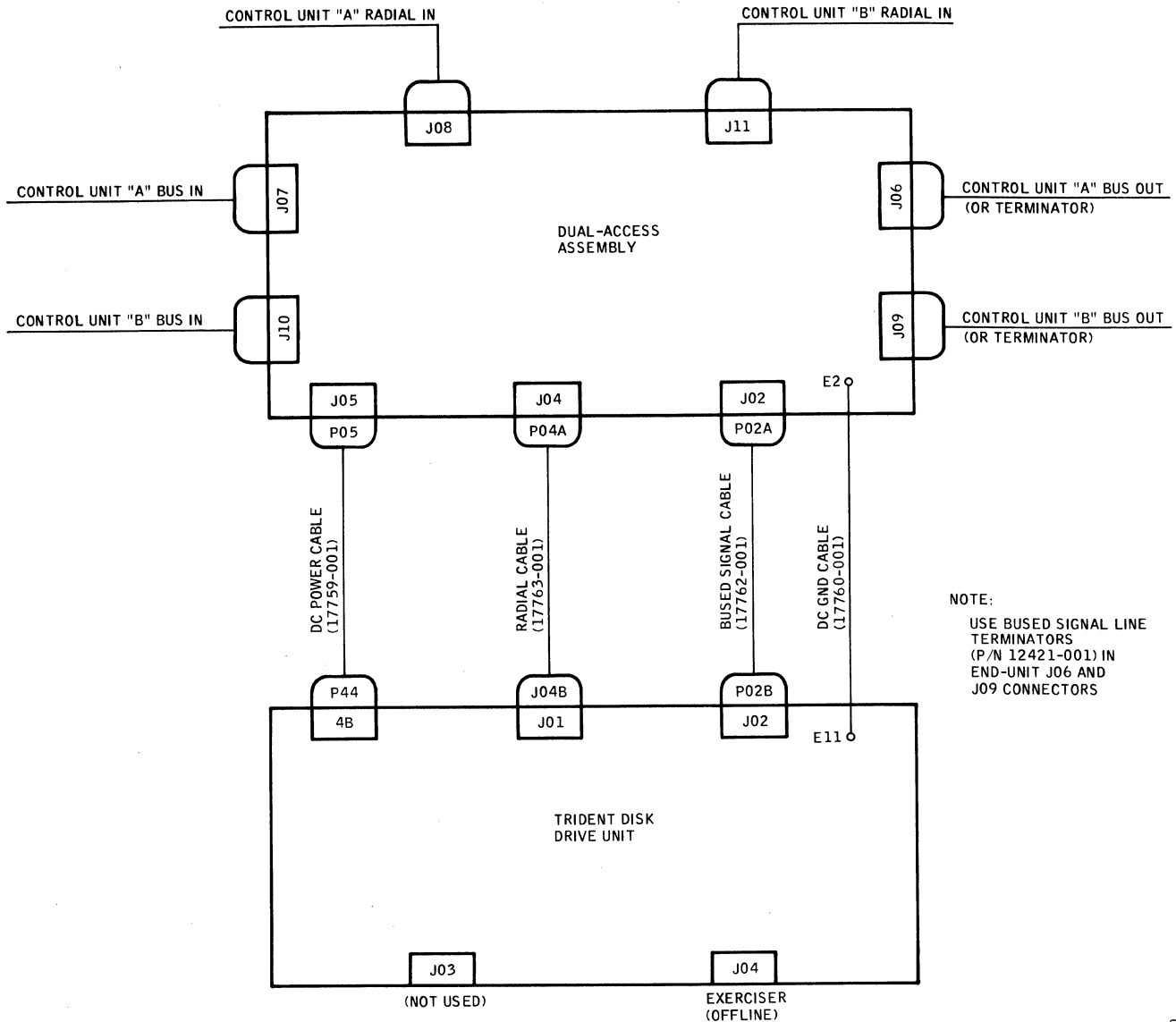

Figure B-2. Dual Access – Disk Drive Interconnection

3. Connect plug P05 of the Dc Power Cable to Dual-Access Assembly receptacle J05 near the right front of the assembly circuit board.
4. Connect a braided Dc Ground Cable (Part No. 17760-001) between disk drive DC GND lug E11 on the card cage assembly and ground lug E2 near the left front of the Dual-Access Assembly board.
5. Connect plug P02B of a Bused Signal Cable (Part No. 17762-001) to disk drive connector J02 and plug P02A of the cable to front connector J02 of the Dual-Access Assembly.
6. Connector plug P04B of a Radial Cable (Part No. 17763-001) to disk drive connector J01 and plug P04 of the cable to front connector J04 of the Dual-Access Assembly. This completes the cabling up of the disk drive. Drive connector J03 is not used and should be open, and connector J04 is for exerciser monitoring or offline exerciser control.
7. Connect the 5-volt outputs of the external power supply to the mating plug for Dual-Access Assembly receptacle J01. The positive output (+5v) must be connected to pin 1 or pin 3 or to both, and the negative output (dc ground) must be connected to pin 2 or pin 4 or to both. Leave the power supply turned off until the installation is completed.
8. While referring to Figure B-3, continue with system interconnection. Connect the radial cable assigned

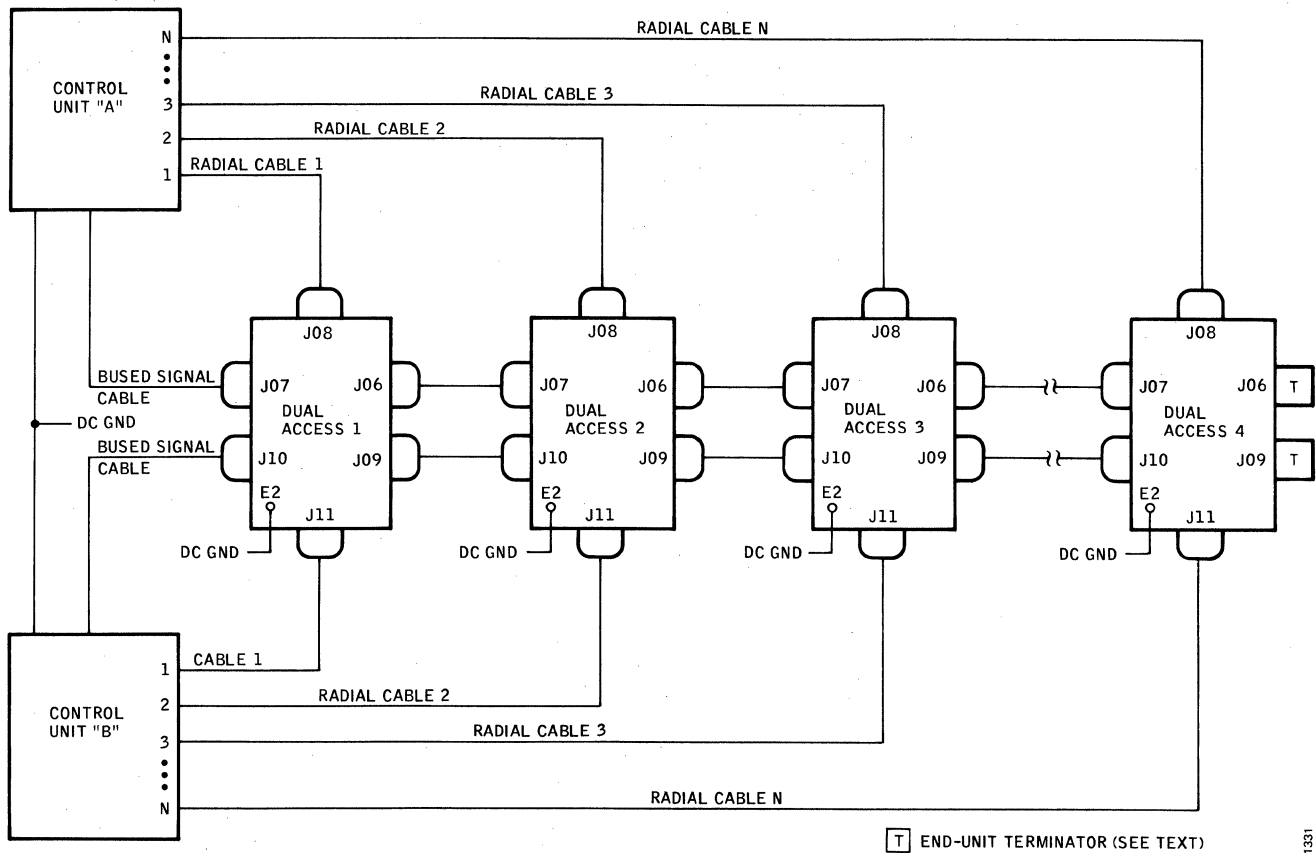

Figure B-3. Control Unit – Dual-Access System Cabling

9. Install bused signal cables between Control Unit A and the various Dual-Access Assemblies in the system, using Dual-Access Assembly rear connectors J07 (IN) and J06 (OUT), as shown in Figure B-3. Standard Bused Signal cables for single access can be used for this purpose. A Signal Line Terminator (Part No. 12421-001) must be plugged into connector J06 of the end unit as noted.
10. Install bused signal cables between Control Unit B and the various Dual-Access Assemblies in the system, using Dual-Access Assembly rear connectors J10 (IN) and J09 (OUT), as shown in Figure B-3. Standard Bused Signal Cables for single access can be used for this purpose. A Signal Line Terminator (Part No. 12421-001) must be plugged into connector J09 of the end unit as noted.
11. Connect dc grounding cables from the E2 terminal of each Dual-Access Assembly radially back to a grounding point shared by both Control Unit A and Control Unit B.
12. After all cables have been connected in the system, dress the ribbon cables from the front connectors of the Dual-Access Assembly flat across the bottom of the chassis assembly, and install four strain-relief bars (7) (two on the top and two on the bottom) to hold the cables in place. See Figure B-1, Views B and C, for strain-relief details. Return to the last two steps under Physical Installation to complete the procedure.

#### TIME COUNT SELECTION

A fail-safe time counter feature in the dual-access logic design prevents the dual-access system from experiencing a hangup condition if a faulty control unit should fail to relinquish access control to the disk drive. When both control units are switch-enabled to share access (automatic mode of operation), this timer counter defines the maximum lockout time that one control unit can inhibit access to the other control unit. If the disconnected control unit requests

access, and the connected control unit shows no tag line activity before the time count is completed, access will be switched to the disconnected control unit.

This time counter has installation significance because the time count is jumper selectable over a range of 0.65 to 39.8 seconds. Time-count time selection is made by means of a set of jumper connections on two IC chip sockets, X13A and X14B, on the Dual-Access Assembly circuit board. Table B-2 lists the significant time counts and the jumper pattern required to obtain each of them. If system fail-safe time needs are undetermined or inconsequential, install jumpers for a time of 10.8 seconds. This is a standard choice.

The fail-safe timer function can also be disabled entirely, meaning that to clear equipment failure hangups will require software or operator detection and intervention. To disable the timer, install two jumpers on IC socket X6C — one between pins 4 and 11 and the other between pins 5 and 10. With these two jumpers installed, it doesn't matter how the fail-safe time counter is jumpered, for it is inhibited from counting.

### CONTROLS AND INDICATORS

The Dual-Access Assembly contains two operator control switches on the front panel, one maintenance switch, and two maintenance indicators, all inside the assembly on the

**TABLE B-2. FAIL-SAFE TIME JUMPER SELECTION**

Approximate Time (Seconds)	Install jumpers in sockets X13A and X14B (pin to pin) as follows:	
	Socket X13A	Socket X14B
0.65	7-8	2-15, 4-13
1.30	7-8	1-16, 3-14
1.95	7-8	1-16, 2-15, 3-14, 4-13
2.60	7-8	5-12, 7-10
3.25	7-8	2-15, 4-13, 5-12, 7-10
3.90	7-8	1-16, 3-14, 5-12, 7-10
4.55	7-8	1-16, 2-15, 3-14, 4-13, 5-12, 7-10
5.20	7-8	6-11, 8-9
5.85	7-8	2-15, 4-13, 6-11, 8-9
6.50	7-8	1-16, 3-14, 6-11, 8-9
7.15	7-8	1-16, 2-15, 3-14, 4-13, 6-11, 8-9
7.80	7-8	5-12, 6-11, 7-10, 8-9
8.45	7-8	2-15, 4-13, 5-12, 6-11, 7-10, 8-9
9.10	7-8	1-16, 3-14, 5-12, 6-11, 7-10, 8-9
9.75	7-8	1-16, 2-15, 3-14, 4-13, 5-12, 6-11, 7-10, 8-9
10.8	6-9	6-11, 8-9
12.2	6-9	2-15, 4-13, 6-11, 8-9
13.5	6-9	1-16, 3-14, 6-11, 8-9
14.8	6-9	1-16, 2-15, 3-14, 4-13, 6-11, 8-9
16.2	6-9	5-12, 6-11, 7-10, 8-9
17.6	6-9	2-15, 4-13, 5-12, 6-11, 7-10, 8-9
18.9	6-9	1-16, 3-14, 5-12, 6-11, 7-10, 8-9
20.2	6-9	1-16, 2-15, 3-14, 4-13, 5-12, 6-11, 7-10, 8-9
21.2	5-10	6-11, 8-9
23.8	5-10	2-15, 4-13, 6-11, 8-9
26.5	5-10	1-16, 3-14, 6-11, 8-9
29.2	5-10	1-16, 2-15, 3-14, 4-13, 6-11, 8-9
31.8	5-10	5-12, 6-11, 7-10, 8-9
34.4	5-10	2-15, 4-13, 5-12, 6-11, 7-10, 8-9
37.1	5-10	1-16, 3-14, 5-12, 6-11, 7-10, 8-9
39.8	5-10	1-16, 2-15, 3-14, 4-13, 5-12, 6-11, 7-10, 8-9

To disable fail-safe timer entirely, install two jumpers in socket X6C between pins 4 and 11 and pins 5 and 10. X6C jumpers can be stored in other pin locations if not used.

printed-circuit board. These controls and indicators are listed in Table B-3, along with their proper nomenclature, location, and function.

### OPERATION

To turn on and operate a Trident Disk Drive equipped with the Dual-Access feature, proceed as follows:

1. Set both the ACCESS A and ACCESS B switches on the Dual-Access front panel to OFF.
2. Turn on the external +5-volt power supply connected to the Dual-Access Assembly.
3. Extend the Dual-Access Assembly forward, and make sure that Degate switch S1 is set to its normal position, as shown by the screened outline on the board. Close the assembly.
4. Set the disk drive START/STOP switch to STOP, and set the PWR ON/OFF switch to ON. The ac power cable of the drive must be plugged in and the INTERFACE/DEGATE switch must be set to INTERFACE.

The Trident Disk Drive and its Dual-Access Assembly are now in an offline, standby condition. To complete the turn-on procedure, continue as follows:

5. To enable Control Unit A access, turn on the ACCESS A switch. Or if the drive is to be operated solely by Control Unit B, leave the ACCESS A switch OFF and turn on the Access B switch. To put the Dual-Access Assembly into automatic mode for access time sharing between the two control units, turn on *both* ACCESS switches.
6. Set the disk drive START/STOP switch to START. The drive may or may not power up and load the heads, depending upon whether or not the connected control unit has activated its Sequence line.

The disk drive is now online and ready to execute commands given by the control unit to which it has been connected.

7. To put the disk drive into the not-ready condition, set the disk drive START/STOP switch to STOP. Actual power-down sequencing will not start until the current operation is completed.
8. To put the disk drive into the offline condition, set both the ACCESS A and the ACCESS B switch to OFF. Again, switch effectiveness will be delayed until the current operation is completed (active tag line drops).

**TABLE B-3. DUAL-ACCESS CONTROLS AND INDICATORS**

Control or Indicator	Description
ACCESS A Switch	Two-position toggle switch located on Dual-Access Assembly front panel. Enables disk drive access by Control Unit A when turned on (up). Enable/disable function of switch is delayed until all tag lines are inactive.
ACCESS B Switch	Two-position toggle switch located on Dual-Access Assembly front panel. Enables disk drive access by Control Unit B when turned on (up). Enable/disable function of switch is delayed until all tag lines are inactive.
Degate Switch (S1)	Two-position toggle switch located inside assembly on circuit board. Turning off switch disconnects the dual-access logic from responding to any control unit commands and also disables all clock, data, and status outputs. Normal operating position (online) of this switch is shown by switch outline on board.
A Connected (DS2) Indicator	Maintenance status LED indicator located on circuit board. Shows that Control Unit A is actively connected to the dual access when indicator is lit.
B Connected (DS1) Indicator	Same location and function as indicator DS2, but for Control Unit B.

9. To put the disk drive into a true Degate condition, turn off both ACCESS switches *and* turn on Degate switch S1 inside the Dual-Access Assembly.

**Note**

*While the Dual-Access Degate switch performs the same degate function as the disk drive INTERFACE/DEGATE switch, the latter switch must still be set to DEGATE if exerciser control of the disk drive is desired.*

10. To shut down the disk drive equipped with dual access with the least possible disturbance to the system, first turn off the ACCESS switch or switches, next set the disk drive START/STOP switch to STOP, and finally turn off the disk drive PWR ON/OFF switch. The external +5-volt power supply to the Dual-Access Assembly probably should not be turned off if either control unit happens to be busy.





**U.S. Sales Offices**

13773 N. Central Expressway  
Dallas, TX 75243  
Phone 214/699-1682

5 Main Street  
Cold Springs Harbor, NY 11724  
Phone 516/367-4101  
TWX 516-367-4292

3375 Scott Blvd., Suite 440  
Santa Clara, CA 95051  
Phone 408/727-2833

2925 Cardinal Drive, Suite E  
Vero Beach, FL 32960  
Phone 305/567-5700  
TWX 910-591-1154

6425 So. Pennsylvania  
Lansing, MI 48901  
Phone 517/393-8088

330 North Belt Expressway  
Suite #107  
Houston, TX 77060  
Phone 713/820-2500

69 Hickory Drive  
Waltham, MA 02154

Orangewood II  
1870 Orangewood Ave., Unit H  
Orange, CA 92667  
Phone 714/997-8780

Century Data Systems, Inc.  
1270 North Kraemer, Anaheim, California 92806  
P.O. Box 3056, Anaheim, California 92803  
For Information Phone (714) 632-7111  
Telex 655437