

49769500



9219X TAPE CARTRIDGE SUBSYSTEM

BY5A3

DESCRIPTION
INSTALLATION AND CHECKOUT
I/O REQUIREMENTS
OPERATION
MAINTENANCE

USERS GUIDE

TABLE OF CONTENTS

PREFACE

The purpose of this Users Guide is to provide information relative to the customers' requirements to properly operate the 9219X Subsystem.

Information contained in this Users Guide includes a general description, power and environmental requirements, operation, operator maintenance, installation, input/output requirements, and sense data.

Equipment Identification - ID plate located on the right side of casting.

BY5A3A - Basic Transport (92190)

BY5A3B - Transport With Bezel (92190)

BY5A3C - Transport With Error Correction (92195)

BY5A3D - Transport With Bezel and Error Correction (92195)

PARAGRAPH TITLE	PAGE
<u>DESCRIPTION</u>	1
<u>INSTALLATION AND CHECKOUT</u>	3
UNPACKING	3
PACKAGE CONTENTS	3
VISUAL INSPECTION	4
BEZEL INSTALLATION (OPTIONAL)	5
POWER REQUIREMENTS	6
SAFETY REQUIREMENTS	7
GROUNDING	7
MOUNTING	7
<u>I/O REQUIREMENTS</u>	8
<u>OPERATION</u>	8
DEVICE STATUS	8
TAPE CARTRIDGE HANDLING	9
OPERATORS INDICATORS (OPTIONAL)	9
HEALTH CHECK	10
<u>MAINTENANCE</u>	11
CLEANING	11
MAINTENANCE REPAIR CENTERS	12
PACKAGING	12

DESCRIPTION

The Quarter Inch Tape Cartridge Subsystem (9219X), referred to as the device, is a microprocessor-based electronic and mechanical assembly intended for use in disk backup applications, using sequential recording techniques in a streaming mode only. The device consists of integrated formatter/control electronics and cartridge drive transport.

Formatter/Control electronics provide data encoding, decoding, error detection, optional error correction, host system interfacing, and control of tape cartridge drive. The tape drive system is an electro-mechanical assembly consisting of cartridge load/unload and positioning mechanism, drive motor/tachometer assembly, positionable single track magnetic head, head positioning mechanism, beginning of tape (BOT)/end of tape (EOT) sense electronics, and optional front mounting bezel with operator indicators.

The tape cartridge used in the device is an industry-standard cartridge containing a 450-foot length, 1/4-inch wide magnetic tape, drive wheel/tensioning band arrangement, BOT/EOT reflector, and file protect port for securing recorded data.

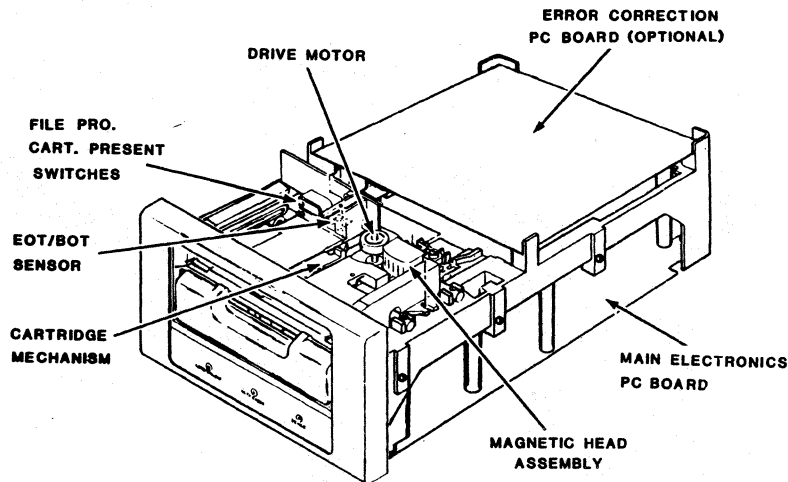

Figure 1. 9219X Tape Cartridge Subsystem

Table 1. Performance Characteristics

Tape Speed	55 inches per second
Recording Mode	Streaming Serpentine Recording
Tape Cartridge	Similar to cartridge per ANSI STD X3.55-1977. Tape is 1/4 inch wide and 450 feet long.
Cartridge Capacity (with 4Kbyte blocks)	48 megabytes without Error Correction Code 45 megabytes with Error Correction Code
Recording Density	8000 bits per inch
Maximum Time To Dump 40 Megabytes	20 minutes
Weight	12 pounds
Dimensions	
Height	4.6 inches
Width	8.5 inches
Depth	14.0 inches maximum. (Bezel extends 0.86 inches to the front.)
Power Voltage	+12V, -12V, +5V
Mounting	Standard EIA Rack, 19-inch vertical or horizontal
Signal Levels	TTL Compatible
Temperature	
Operating	50°F (10°C) to 104°F (40°C)
Storage	14°F (-10°C) to 122°F (50°C)
Transit	-40°F (-40°C) to 140°F (60°C)
Humidity	
Operating	20% to 80% (No Condensation) with a Dew Point Temperature of 25°F (-4°C) to 79°F (26°C)
Storage	10% to 90% (No Condensation)
Transit	5% to 95% (No Condensation)
Altitude	-983 feet (-300 meters) to 9850 feet (3000 meters)

CAUTION

Though device shall be fully operational through the above limits, degraded read/write performance will be expected based on known performance characteristics of tape media, if unit is operated outside the following limits:
 Temperature: -60°F (-16°C) to 90°F (32°C)
 Humidity: 35% to 60% R.H.
 Wet Bulb Temperature: 79°F (26°C)

INSTALLATION AND CHECKOUT

Unpacking

Unpack the device as follows:

1. Remove the two-port styrofoam shell from the cardboard shipping container.
2. Lift top half of styrofoam shell from device.
3. Lift unit in polyethylene bag from bottom half of styrofoam shell and remove unit from polyethylene bag.
4. Remove restraints securing gimbaled capstan motor and positionable head carriage. Also remove foam blocks supporting PC boards if applicable.
5. Retain all packaging material for reuse.

During unpacking, inspect the device for possible shipping damage. All claims for this type of damage should be filed promptly with the carrier involved. If a file is claimed for damages, save the original packing materials.

Package Contents

The packaged unit may or may not have parts and hardware requiring assembly, depending on the model of the device. Identify the device by the BY5A3 (A,B,C or D) number located on the Equipment Identification plate on the left side of the device. Check package contents versus BY number as follows:

BY5A3A - Device Only

- | | |
|--|------------------------------|
| BY5A3B - 1. Device | 5. Nuts, Hex (2) #6-32 |
| 2. Bezel Assembly | 6. Washers, Flat (4) |
| 3. Indicator Panel Strips
(Horizontal & Vertical) | 7. Washers, Lock (2) |
| 4. Screws (2) #6-32 x .375 | 8. Installation Instructions |

BY5A3C - Device With Error Correction Code PWA Installed.

Package Contents (Cont'd)

- | | |
|---|------------------------------|
| BY5A3D - 1. Device With Error Corr.
Code PWA Installed | 4. Screws (2), #6-32 x 0.375 |
| 2. Bezel Assembly | 5. Nuts, Hex (2), #6-32 |
| 3. Indicator Panel Strips
(Horizontal & Vertical) | 6. Washers, Flat (4) |
| | 7. Washers, Lock (2) |
| | 8. Installation Instructions |

Visual Inspection

Visually inspect the following areas of the device and bezel assembly prior to mounting:

- Indicator Panel

Check for cracks, scratches or abrasions.

- Connectors

Inspect for proper mating of plugs to connectors.

- PC Board

Check for proper seating of all pluggable integrated circuits and daughter boards.

Bezel Installation (Option)

Attach the bezel assembly to the device as follows: (See Figure 2)

1. Position bezel assembly at front of device and attach connector of bezel cable to J12 connector on front of device PC board.
2. Locate bezel to the front of the device by sliding the two lower mounting studs into slots on the device (see Figure 2). Position the bezel up against the underside of the tape cartridge guides.
3. Install two self-threading screws through the top mounting slots of the device and into the mounting holes provided at the top rear of the bezel.
4. Insert hex nuts onto the lower mounting studs to secure the bottom of bezel.
5. Select appropriate indicator panel (horizontal or vertical), remove release paper, position the panel into the recess provided, and apply moderate pressure to ensure good adhesion.

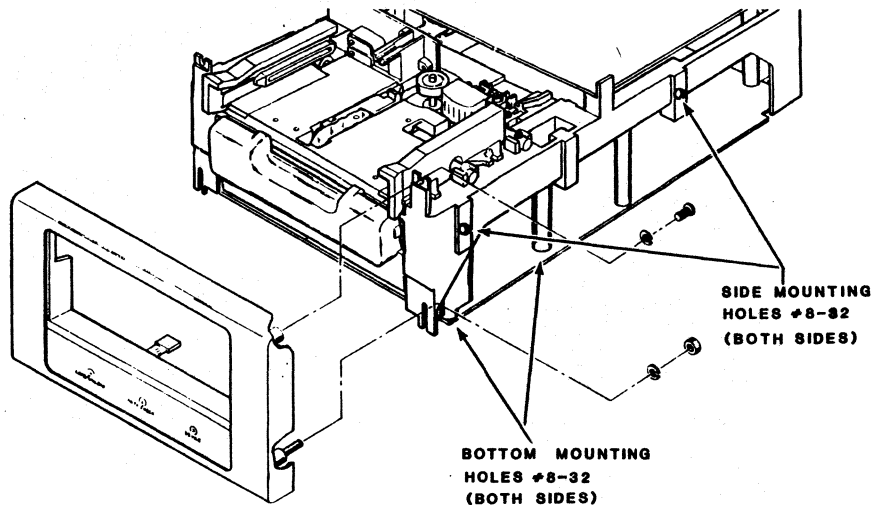

Figure 2. Bezel Installation

Power Requirements

Input power for operation of the DC motors and PC board assembly must be supplied remotely via the power connector J13 located at the rear of the device. The device does not have an internal power supply. Voltage/Current requirements are as follows:

OPERATING CONDITION	VOLTAGE		
	+12V \pm 10%*	-12V \pm 10%*	+5V \pm 5%**
92195 Forward Motion	2.0A	0.6A	4A
92195 Reverse Motion	1.0A	1.7A	4A
92190 Forward Motion	2.0A	0.6A	3A
92190 Reverse Motion	1.0A	1.7A	3A

- * Maximum average power during tape motion. 4.0A surge for 100 msec during start/stop. Ripple not to exceed 250 mv.
 ** Maximum continuously, ripple not to exceed 100 mv.

NOTE

Voltage supplied to the device must be provided by a "SAFETY EXTRA LOW VOLTAGE" source, as defined by IEC 380.

The power connector J13 mates with an AMP Connector Housing P/N 1-480702-0 and Contact Socket P/N 350551-1 or equivalent. Pin assignments for the connector are as follows:

ASSIGNMENT	PIN
-12V	1
+12V	2
GND	3
+5V	4

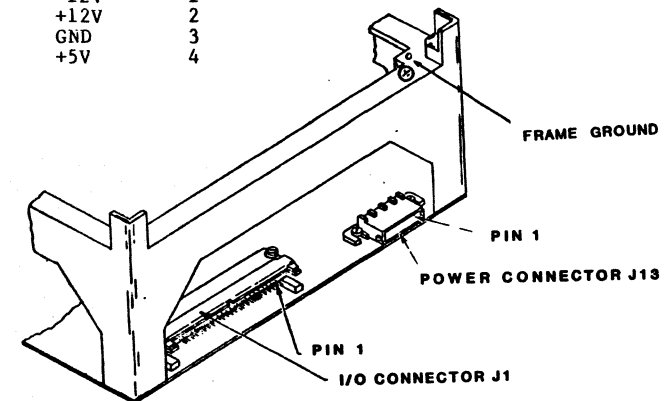

Figure 3. Power and I/O Connector Locations

Safety Requirements

In order to maintain Safety Organization Certification, it is required to comply with the following:

- o Each supply voltage should be fused at no more than 5.0 amps.
- o Grounding continuity must be maintained between the device frame and host equipment.

Grounding

A #8-32 tapped hole is provided at the rear of the device for grounding of the frame.

I/O REQUIREMENTS

The device interface input and output signals are all TTL Compatible. Device inputs are terminated with a 220-330 ohm resistor network, while the outputs are driven with an open-collector output stage. I/O signal levels are low true between Host and Device. I/O connector J1 mates with Berg Connector P/N 65847-033 or equivalent.

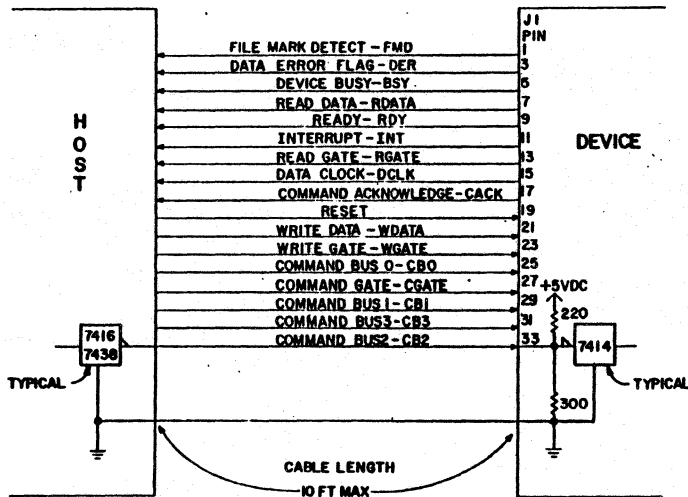

Figure 4. I/O Lines and Pin Assignments

Mounting

The device can be installed in a user mounting unit either in a horizontal or vertical (left side up) position. The only consideration for cabinet or other enclosed mounting unit is defined by the environmental requirements listed in Table 1.

Mounting holes are provided (Figure 2) on the side and bottom of the device to accommodate either horizontal or vertical mounting. Mounting with drawer-type slides is suggested to provide easy access for operator maintenance.

OPERATION

Device Status

There is no power "ON" or "OFF" switch on the device. As long as the power connector is attached, the device is in a Ready condition. If the optional front indicator panel is used, the operational status of the device is indicated by the operator indicators. Refer to OPEATOR INDICATORS (OPTIONAL) paragraph. If the front indicator panel is not used, device status is available to the host controller via the sense data lines.

Tape Cartridge Handling

CAUTIONS

Under no circumstances should operator allow finger contact with either magnetic tape or cartridge drive capstan. Any residue from contact with the device wheel may affect friction requirements between drive wheel and cartridge capstan.

If cartridge is dropped or otherwise mishandled, it is suggested that operator issue a Cartridge Health Check command to verify that cartridge is operational.

- Storage

The cartridge can withstand storage temperature ranges from 41°F (5°C) to 113°F (45°C). The cartridge should be conditioned, by exposure to the operating environment, a time equal to or greater than time away from operating environment (up to 8 hours maximum).

- Cartridge Loading

Insert a cartridge into the device with the clear plastic surface toward the top of the device (device mounted horizontally). When the cartridge is partially positioned in the slot, position thumb at the center of the cartridge and push until the release bar latches the cartridge in place.

- Cartridge Unloading

Press the release bar away from the cartridge until it latches in the open position. The cartridge will be automatically extended about one inch so that it can be removed from the device.

Operators Indicators (Optional)

The front bezel and operator indicators are provided as an option to the standard device. Indicator functions are as follows:

- Load/Unload

When illuminated, indicates a cartridge can be inserted or removed without interrupting the device function in progress.

- Data Check

When illuminated, indicates that excessive read or write errors have been detected. It is recommended that the magnetic head be cleaned to maintain read/write performance. Successive data checks may indicate a defective cartridge.

- Device

When illuminated, indicates that the Health Check Routine or functional microcode has detected a fault within the device hardware, and the device is not operational.

Data Check and Device indicators remain active until the Host issues a Sense command.

Health Check

Basic operational tests executed after power-on, on the following areas of the device to ensure the device meets minimum operating conditions, are as follows:

- o Microprocessor RAM Memory
- o Drive Motion - Speed, Acceleration and Deceleration
- o Head Positioner Motion
- o BOT/EOT Lamp Current Presence
- o Write-to-Read Loopback Through Encoding and Decoding Logic (Magnetic Head, Read Amplifier, and Write Drivers excluded)
- o Normal Device Status

NOTE

A full Health Check cannot be evoked if the cartridge is loaded. If the cartridge is loaded during a power-on, an abbreviated Health Check is performed, with no capstan motion or write-to-read loopback.

MAINTENANCE

Cleaning

The only areas requiring operator cleaning are the magnetic head and drive wheel.

- Magnetic Head/Tape Cleaner Assembly

Clean head surface using cotton swab moistened with tape transport cleaner P/N 95961030. Move cotton swab in a vertical direction (perpendicular to tape motion) across the head recording surface and cleaner blades. Perform this cleaning procedure twice a week or whenever required by the operator indicator (DATA CHECK).

- Drive Roller

The drive roller should be cleaned on a monthly basis. Clean the roller using a cloth moistened with tape transport cleaner P/N 95961030. Use a cloth-covered finger of one hand to move drive roller while cleaning with dampened cloth on other hand.

Maintenance Repair Centers

Contact the nearest Control Data Sales Office for repair center locations.

Packaging

If it is necessary to reshipe the device, use the original packaging material and repackage the device as follows:

NOTE

If it is necessary to order new packaging for the device, contact:

Computer Peripherals, Inc.
Business Management Office
2621 Van Buren Avenue
Norristown, PA. 19403

When ordering, specify the exact equipment number and series code of the device, as shown on the Equipment Identification label.

1. Install restraints to secure the gimbaled capstan motor and positionable head carriage. Also install foam blocks to support PC boards mounted to main board if applicable.
2. Place unit into polyethylene bag and place in bottom half of styrofoam shell.
3. Place top half of styrofoam shell onto device and place in cardboard shipping container.
4. Secure cardboard container with reinforced tape.