

Burroughs 

B 1000 Systems 1400 Interpreter

REFERENCE MANUAL

Copyright © 1981, Burroughs Corporation, Detroit, Michigan 48232

PRICED ITEM

“The names used in this publication are not of individuals living or otherwise. Any similarity or likeness of the names used in this publication with the names or any individual, living or otherwise, is purely coincidental and not intentional.”

Burroughs believes that the information described in this document is accurate and reliable, and much care has been taken in its preparation. However, no responsibility, financial or otherwise, is accepted for any consequences arising out of use of this information.

The information contained herein is subject to change without notice. Revisions may be issued to advise of such changes and/or additions.

Correspondence regarding this publication should be forwarded using the Remarks form at the back of the manual, or may be addressed directly to TIO West Documentation, Burroughs Corporation, 1300 John Reed Court, City of Industry, California 91745, U.S.A.

LIST OF EFFECTIVE PAGES

| Page | Issue |
|----------------------|----------|
| Title | Original |
| ii | Original |
| iii | Original |
| iv | Blank |
| v thru vi | Original |
| 1-1 thru 1-5 | Original |
| 1-6 | Blank |
| 2-1 thru 2-3 | Original |
| 2-4 | Blank |
| 3-1 thru 3-11 | Original |
| 3-12 | Blank |
| 4-1 thru 4-27 | Original |
| 4-28 | Blank |
| 5-1 thru 5-5 | Original |
| 5-6 | Blank |
| 6-1 thru 6-3 | Original |
| 6-4 | Blank |
| Index-1 thru Index-2 | Original |

TABLE OF CONTENTS

| Section | Title | Page |
|---------|---|------|
| 1 | INTRODUCTION | 1-1 |
| | General | 1-1 |
| | Interpreter Features | 1-1 |
| | Hardware Configuration | 1-2 |
| | Organization | 1-2 |
| | Related Documents | 1-2 |
| | Syntax Conventions | 1-2 |
| | Required Items | 1-3 |
| | Optional Items | 1-3 |
| | Loops | 1-4 |
| | Bridges | 1-4 |
| | Names | 1-5 |
| 2 | INSTRUCTIONS INTERPRETED | 2-1 |
| | General | 2-1 |
| | Input/output Instructions | 2-1 |
| | Arithmetic Instructions | 2-1 |
| | Logical Instructions | 2-2 |
| | Move and Load Instructions | 2-2 |
| | Magnetic Tape Instructions | 2-2 |
| | Disk Instructions | 2-3 |
| | Supervisory Console Instructions | 2-3 |
| | Miscellaneous Instructions | 2-3 |
| 3 | 1400/IEP | 3-1 |
| | General | 3-1 |
| | Syntax Notation | 3-1 |
| | Syntax of the 1400/IEP | 3-1 |
| | Main Syntax | 3-1 |
| | Memory Size Declaration | 3-2 |
| | Card Reader Declaration | 3-2 |
| | Line Printer Declaration | 3-3 |
| | Card Punch Declaration | 3-4 |
| | Hardware Declaration | 3-5 |
| | Disk Declaration | 3-6 |
| | Tape Declaration | 3-7 |
| | Console Declaration | 3-8 |
| | Optional Declarations | 3-8 |
| | Compilation | 3-9 |
| 4 | INTERPRETER OPERATION | 4-1 |
| | 1400 Interpreter Commands | 4-1 |
| | Send Console Printer Data to 1400 Program | 4-2 |
| | Alter 1400 Memory | 4-3 |
| | Clear 1400 Console Printer | 4-4 |
| | Display 1400 Memory | 4-5 |
| | Dump 1400 Memory | 4-6 |
| | End 1400 Program | 4-7 |
| | Close B 1000 File | 4-8 |
| | Terminate | 4-9 |

TABLE OF CONTENTS (Cont)

| Section | Title | Page |
|---------|---|------|
| | 1400 Address Conversion | 4-10 |
| | Load 1400 Program | 4-11 |
| | Continue 1400 Processing | 4-12 |
| | Set/Reset Disk Keys | 4-13 |
| | Resume Regular Mode | 4-14 |
| | Reset 1400 Processor | 4-15 |
| | Restart 1400 Processing | 4-16 |
| | Set 1400 Memory to a Character | 4-17 |
| | Begin Single Step Mode | 4-18 |
| | Start 1400 Processing | 4-19 |
| | Stop 1400 Processing | 4-20 |
| | Set 1400 Sense Switches | 4-21 |
| | Transfer to 1400 Memory Location | 4-22 |
| | Inquire Status | 4-23 |
| | Operator Display Terminal Comment | 4-24 |
| | Line Printer Comment | 4-25 |
| | INTOPT | 4-26 |
| | SYSIN INTOPT Option | 4-26 |
| | 1400 Read Column Binary | 4-27 |
| 5 | MCP INTERFACE | 5-1 |
| | General | 5-1 |
| | Environment Parameter Changes | 5-1 |
| | Tape Assignment | 5-3 |
| | Disk Assignment | 5-3 |
| | 1400 Instruction Tracing | 5-4 |
| | B 1000 Program Switches | 5-4 |
| 6 | 1400/CREATE1311 | 6-1 |
| | General | 6-1 |
| | Operating Procedures | 6-1 |
| | 1400 IBM 1311 Disk Initialization | 6-2 |

LIST OF ILLUSTRATIONS

| Figure | Title | Page |
|--------|------------------------|------|
| 5-1 | Trace Output | 5-5 |

SECTION 1 INTRODUCTION

GENERAL

The 1400 Interpreter allows original IBM 1401/1440/1460 (hereafter referred to as 1400) users to take object programs, data, pertinent operating instructions, and all 1400 system software to a B 1000 system and to execute the program as if the B 1000 were a 1400 system. Multiprogramming, given sufficient memory, is possible in an environment with several 1400 system emulations or with mixed 1400 emulations and B 1000 programs.

Emulation is the process of creating a foreign systems environment in a central processor through the use of a hardware-assisted program, or in the case of a fourth-generation processor, through the use of variable micrologic. The 1400 Interpreter allows 1400 object programs to execute on a B 1000 system under the control of the B 1000 Master Control Program II (MCP).

The microcoded 1400 Interpreter resides in the B 1000 memory. The 1400 Interpreter provides a soft interface between the 1400 object program and the B 1000 I/O system and the MCP, and also interprets the 1400 instruction set.

The operating procedures normally used for the 1400 object program have been changed slightly because the 1400 object program is executed under control of the B 1000 MCP. The normal, full range of operator procedures of 1400 systems are now performed by entering B 1000 Operator Display Terminal (ODT) messages. This provides an audit of the operator functions, which is an additional aid to management.

The peripheral units are, in most cases, common to the 1400 and B 1000 systems. This allows continuity from an operational standpoint. If a change in peripherals is desired, such as exchanging a 750-LPM for a 1100-LPM printer, it is completely "transparent" to the 1400 Interpreter. In the case of switching from 7-channel tapes to NRZ or PE 9-channel tapes, it is only necessary to copy the tapes using a 1400 copy program executed by the 1400 Interpreter.

1400 disk files have to be transferred from the 1400 system to the B 1000 system. To accomplish this, the disk files must be dumped to tape on the 1400 system, converted to 9-track tape if the B 1000 system is to be configured with only 9-track tape drives, and then reconstructed under emulation on the B 1000 system using an available 1400 tape-to-disk utility program.

INTERPRETER FEATURES

The 1400 Interpreter provides the following features:

- The interpreter has the same operating environment as defined for the original 1400 object program.
- All halts allow the operator to continue, reset, load a new program, or start at another 1400 address.
- The 1400 arithmetic logic is maintained during execution of the 1400 object program.
- The 1400 comparison-indicator logic is maintained during execution.
- One level of address indexing is emulated.
- The A-address and B-address registers are maintained during execution.
- The 1400 sense switches A through G are emulated.
- A dump of 1400 memory is available.
- A trace of the 1400 instructions is available.

HARDWARE CONFIGURATION

The following hardware configuration represents the maximum system that can be emulated in a single environment.

| Quantity | Item |
|----------|----------------------------|
| 1 | 80-column card reader |
| 1 | 80-column card punch |
| 1 | Line printer |
| 5 | 1311 disk drives |
| 6 | Magnetic tape units |
| 1 | Console printer |
| 1 | 4K, 8K, 12K, or 16K memory |

If the hardware configuration of the B 1000 site does not contain adequate hardware to support the full requirements of the emulated system, a limited device equation may be made by means of the B 1000 MCP. 1400 tape units cannot be file equated to any device other than tape.

ORGANIZATION

A brief description of the contents of the individual sections of the manual follows:

Section 1 is the introduction and describes the format of the syntax diagrams.

Section 2 describes the 1400 instructions that are emulated.

Section 3 describes the function of the 1400/IEP program.

Section 4 describes the 1400 Interpreter commands.

Section 5 describes some of the special features available through the B 1000 MCP to the 1400 Interpreter.

Section 6 describes the program 1400/CREATE1311.

RELATED DOCUMENTS

B 1000 Systems System Software Operation Guide, Volume 1, form number 1108982.

B 1800/B 1700 Systems System Software Operation Guide, Volume 2, form number 1108966.

SYNTAX CONVENTIONS

Railroad diagrams show how syntactically valid statements can be constructed.

Following a railroad diagram from left to right, or in the direction of the arrow heads, and adhering to the limits illustrated by bridges will produce a syntactically valid statement. Continuation from one line of a diagram to another is represented by a right arrow appearing at the end of the current line and the beginning of the next line. The complete syntax diagram is terminated by a vertical bar (|).

Items contained in broken brackets (< >) are syntactic variables which are further defined in the text, and which require the user to supply the requested information.

Upper-case items must appear literally.

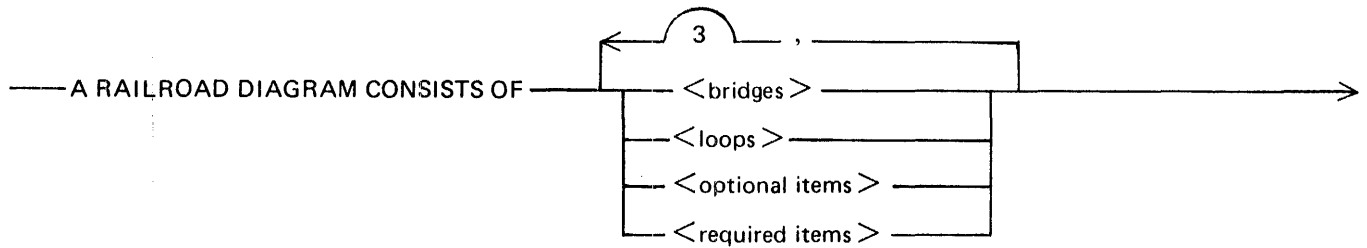

AND IS TERMINATED BY A VERTICAL BAR.

G50051

The following syntactically valid statements may be constructed from the above diagram:

A RAILROAD DIAGRAM CONSISTS OF <bridges> AND IS TERMINATED BY A VERTICAL BAR.

A RAILROAD DIAGRAM CONSISTS OF <optional items> AND IS TERMINATED BY A VERTICAL BAR.

A RAILROAD DIAGRAM CONSISTS OF <bridges>, <loops> AND IS TERMINATED BY A VERTICAL BAR.

A RAILROAD DIAGRAM CONSISTS OF <optional items>, <required items>, <bridges>, <loops> AND IS TERMINATED BY A VERTICAL BAR.

REQUIRED ITEMS

No alternate path through the railroad diagram exists for required items or required punctuation.

Example:

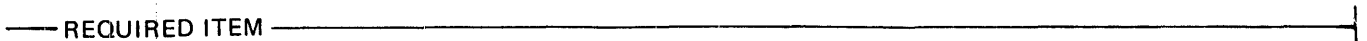

G50052

OPTIONAL ITEMS

Items shown as a vertical list indicate that the user must make a choice of the items specified. An empty path through the list allows the optional item to be absent.

Example:

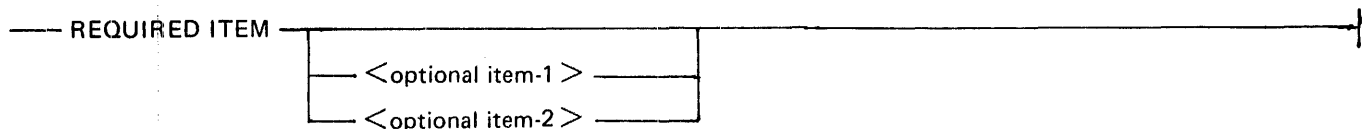

G50053

The following valid statements may be constructed from the above diagram:

REQUIRED ITEM
 REQUIRED ITEM <optional item-1>
 REQUIRED ITEM <optional item-2>

LOOPS

A loop is a recurrent path through a railroad diagram and has the following general format.

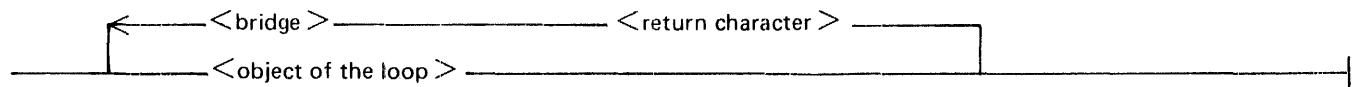

G50054

Example:

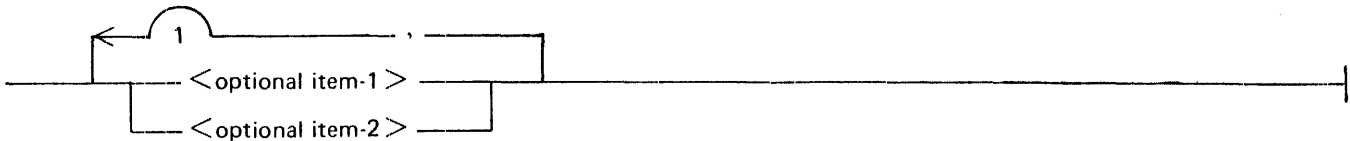

G50055

The following statements can be constructed from the railroad diagram in the example.

<optional item-1>
 <optional item-2>
 <optional item-1>, <optional item-1>
 <optional item-1>, <optional item-2>
 <optional item-2>, <optional item-1>
 <optional item-2>, <optional item-2>

A loop must be traversed in the direction of the arrow heads, and the limits specified by bridges cannot be exceeded.

BRIDGES

A bridge illustrates the minimum or maximum number of times a path may be traversed in a railroad diagram.

There are two forms of bridges.



n is an integer which specifies the maximum number of times the path may be traversed.



n* is an integer which specifies the minimum number of times the path must be traversed.

G50056

Example:

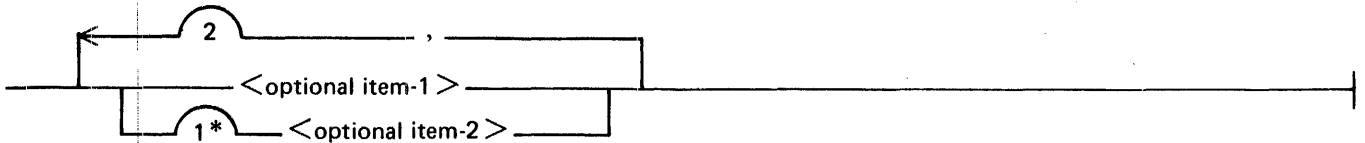

G50057

The loop may be traversed a maximum of two times; however, the path for <optional item-2> must be traversed at least one time.

The following statements can be constructed from the railroad diagram in the example.

```
<optional item-1>,<optional item-2>  
<optional item-2>,<optional item-2>,<optional item-1>  
<optional item-2>
```

NAMES

A name consists of one to ten alphanumeric characters. In the syntax diagrams, <pack-name>, <family-name>, <file-name>, and <environment-name> are regarded as names. A slash character (and no embedded blanks) is used between <pack-name>, <family-name>, and <file-name> when multiple names are used. Refer to the B 1000 Systems System Software Operation Guide, Volume 1, form number 1108982, for a complete description of <pack-name>, <family-name>, and <file-name>.

SECTION 2

INSTRUCTIONS INTERPRETED

GENERAL

The following types of 1400 instructions are interpreted by the 1400 Interpreter:

- Input/Output
- Arithmetic
- Logical
- Move and Load
- Magnetic Tape
- Disk
- Supervisory Console
- Miscellaneous

INPUT/OUTPUT INSTRUCTIONS

The following is a list of 1400 input/output instructions interpreted by the 1400 Interpreter:

- READ CARD (AND BRANCH)
- WRITE LINE (AND BRANCH)
- WRITE WORDMARKS (AND BRANCH)
- WRITE LINE AND SUPPRESS (AND BRANCH)
- WRITE AND READ CARD (AND BRANCH)
- WRITE WORDMARKS AND READ CARD (AND BRANCH)
- WRITE LINE, SUPPRESS AND READ CARD (AND BRANCH)
- PUNCH CARD (AND BRANCH)
- READ AND PUNCH CARDS (AND BRANCH)
- WRITE LINE AND PUNCH CARD (AND BRANCH)
- WRITE WORDMARKS AND PUNCH CARD (AND BRANCH)
- WRITE LINE, SUPPRESS AND PUNCH CARD (AND BRANCH)
- WRITE LINE, READ AND PUNCH CARDS (AND BRANCH)
- WRITE WORDMARKS, READ AND PUNCH CARDS (AND BRANCH)
- WRITE LINE, SUPPRESS, READ AND PUNCH CARDS (AND BRANCH)
- START READ FEED (treated as a NO-op)
- START PUNCH FEED (treated as a NO-op)

ARITHMETIC INSTRUCTIONS

The following is a list of 1400 arithmetic instructions interpreted by the 1400 Interpreter:

- ADD
- SUBTRACT
- ZERO AND ADD
- ZERO AND SUBTRACT
- MULTIPLY
- DIVIDE

LOGICAL INSTRUCTIONS

The following is a list of 1400 logical instructions interpreted by the 1400 Interpreter:

BRANCH UNCONDITIONAL
BRANCH IF EQUAL COMPARE
BRANCH IF HIGH COMPARE
BRANCH IF LOW COMPARE
BRANCH IF UNEQUAL COMPARE
BRANCH IF ARITHMETIC OVERFLOW
BRANCH IF CHARACTER EQUAL
BRANCH IF BIT EQUAL
BRANCH IF END OF REEL
BRANCH IF TAPE TRANSMISSION ERROR
BRANCH IF I/O CHECK STOPS OR BUSY (treated as a NO-op)
BRANCH IF INQUIRY INDICATOR ON
BRANCH IF CLEAR INDICATOR
BRANCH IF LAST CARD INDICATOR ON (sense switch A)
BRANCH IF SENSE SWITCH ON (switches B through G)
BRANCH IF WORDMARK AND/OR ZONE CONDITION
BRANCH IF VALIDITY ERROR
BRANCH IF WRONG LENGTH DISK RECORD
BRANCH IF UNEQUAL DISK ADDRESS COMPARE
BRANCH IF ANY DISK ERROR CONDITION
BRANCH IF DISK ACCESS BUSY (treated as a NO-op)

MOVE AND LOAD INSTRUCTIONS

The following is a list of 1400 move and load instructions interpreted by the 1400 Interpreter:

LOAD CHARACTERS TO A WORDMARK
MOVE NUMERIC
MOVE ZONE
MOVE CHARACTERS AND EDIT
MOVE CHARACTERS TO RECORDMARK OR GROUPMARK W/WORDMARK
MOVE CHARACTERS AND SUPPRESS ZEROS
MOVE CHARACTERS TO A-FIELD OR B-FIELD WORDMARK

MAGNETIC TAPE INSTRUCTIONS

The following is a list of 1400 magnetic tape instructions interpreted by the 1400 Interpreter:

BACKSPACE ONE RECORD
READ TAPE
READ TAPE WITH WORDMARKS
REWIND TAPE
REWIND TAPE AND UNLOAD
SKIP AND BLANK TAPE (ERASE)
WRITE TAPE
WRITE TAPE WITH WORDMARKS
WRITE TAPEMARK
DIAGNOSTIC READ TAPE

NOTE

Because of B 1000 hardware restrictions, 7-track tape records of less than eight characters cannot be written or read.

DISK INSTRUCTIONS

The following is a list of 1400 disk instructions interpreted by the 1400 Interpreter:

READ DISK SECTORS
READ DISK SECTORS WITH WORDMARKS
READ DISK WITH SECTOR COUNT OVERLAY
READ DISK WITH SECTOR COUNT OVERLAY WITH WORDMARKS
READ DISK TRACK WITH ADDRESSES
READ DISK TRACK WITH ADDRESSES AND WITH WORDMARKS
SEEK DISK
WRITE DISK SECTORS
WRITE DISK SECTORS WITH WORDMARKS
WRITE DISK CHECK
WRITE DISK CHECK WITH WORDMARKS
WRITE DISK WITH SECTOR COUNT OVERLAY
WRITE DISK WITH SECTOR COUNT OVERLAY WITH WORDMARKS
WRITE DISK TRACK WITH ADDRESSES
WRITE DISK TRACK WITH ADDRESSES AND WITH WORDMARKS
SCAN DISK
SCAN DISK WITH WORDMARKS

SUPERVISORY CONSOLE INSTRUCTIONS

The following is a list of 1400 supervisory console messages interpreted by the 1400 Interpreter (for 1407/1447 only):

READ CONSOLE
READ CONSOLE WITH WORDMARKS
WRITE CONSOLE
WRITE CONSOLE WITH WORDMARKS

MISCELLANEOUS INSTRUCTIONS

The following is a list of miscellaneous 1400 instructions interpreted by the 1400 Interpreter:

COMPARE
CONTROL CARRIAGE ON PRINTER
CLEAR STORAGE (AND BRANCH)
CLEAR WORDMARK
HALT (AND BRANCH)
MODIFY ADDRESS
NO OPERATION
STORE A-ADDRESS REGISTER
STORE B-ADDRESS REGISTER
SET WORDMARK
SELECT STACKER (READ SELECT AND PUNCH SELECT)

SECTION 3 1400/IEP

GENERAL

The 1400 Interpreter Environment Program (1400/IEP) is used to establish an environment codefile for execution under control of the B 1000 MCP. This environment codefile is also used by the 1400 Interpreter in its processing. Establishing an environment file parallels the compilation of a B 1000 programming language except that there is no object code produced, 1400 or otherwise.

Input to the 1400/IEP describes such items as 1400 memory size, peripheral configuration, 1400 Interpreter special options, and B 1000 file information.

SYNTAX NOTATION

The 1400/IEP specifications are shown using railroad diagrams. The specifications are in free-form format and are located in the input record positions 1 through 72, with positions 73 through 80 used for program identification or sequence numbers.

A percent sign (%) delimits the scanning of the record; text following the “%” is ignored. The “%” must be used to precede comments.

If specifications conflict, the most recent one is used.

SYNTAX OF THE 1400/IEP

The paragraphs that follow describe the syntax of the 1400/IEP. Examples that show the use of each declaration are included.

MAIN SYNTAX

The main syntax consists of the memory, peripheral, or optional declarations, in any order.

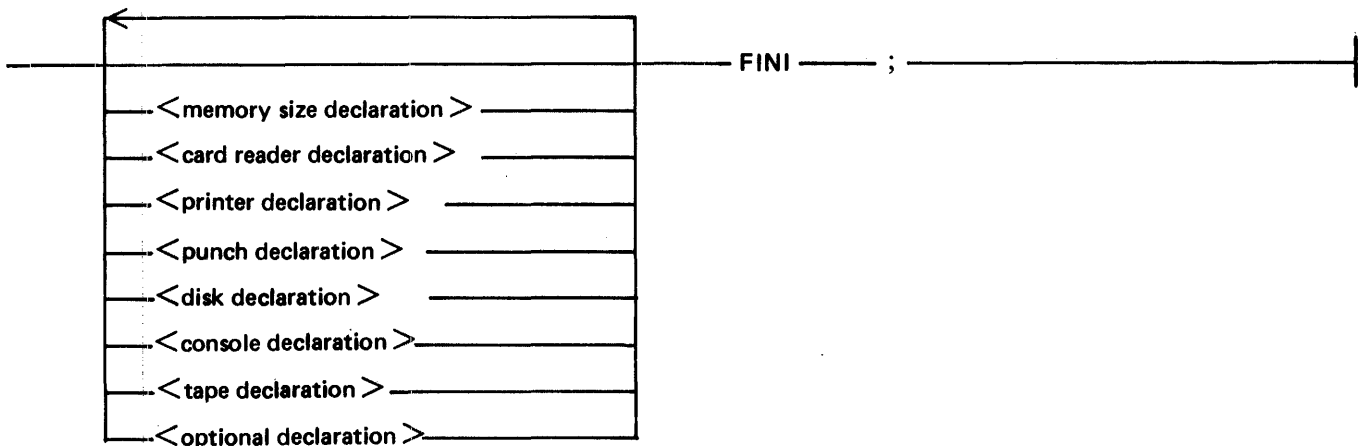

G12351

The declarations are terminated by the keyword FINI.

1127560

MEMORY SIZE DECLARATION

The memory size declaration indicates the 1400 machine memory size. Memory size may be 4K, 8K, 12K or 16K. The default is 16K.

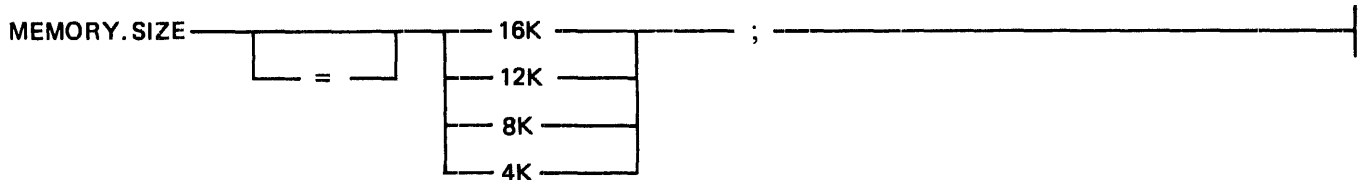

G12352

An example of a MEMORY.SIZE declaration follows:

```
MEMORY.SIZE = 16K;
```

CARD READER DECLARATION

The card reader declaration may be used to specify the name and type of B 1000 device for the 1400 card input.

Syntax:

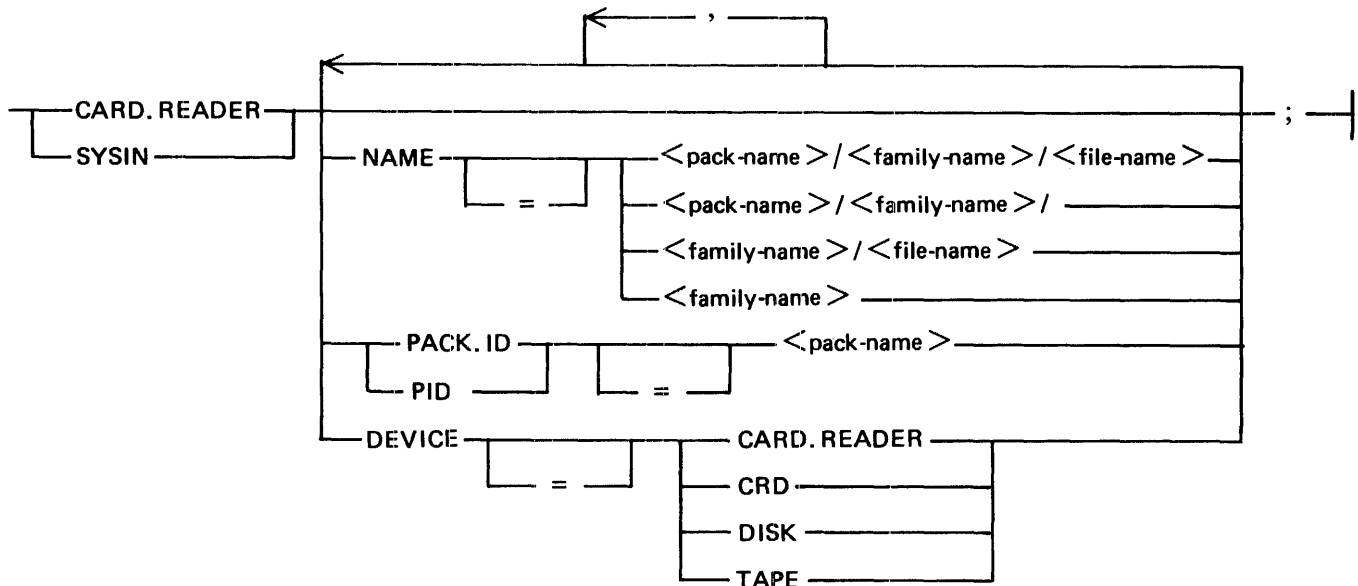

G12353

There are two types of card input to the 1400, card files and SYSIN card files. CARD.READER specifies the attributes of the card reader. SYSIN specifies the attributes of the SYSIN card deck. The SYSIN card file is used with the INTOPT SYSIN option described in Section 4.

The NAME specifies the B 1000 file name of the 1400 card file. If the 1400 card input is from a B 1000 card reader, the name is used on the B 1000 label (DATA) card that must precede the card deck. The card deck is terminated by a B 1000 END card. If the 1400 card input is a B 1000 disk file, then the name is the B 1000 disk file name. The default name is CARDS.1400.

When the 1400 card input is a B 1000 disk file, the PACK.ID or PID may be used to specify the B 1000 user pack identification.

The DEVICE specifies the B 1000 device from which the 1400 card file is to be read. CARD.READER or CRD specifies a B 1000 card reader. DISK specifies a B 1000 disk. TAPE specifies a B 1000 tape file. 1400 card files can be loaded to B 1000 disk or tape with B 1000 system utility programs, as described in the B 1800/B 1700 Systems System Software Operation Guide, Volume 2, form number 1108966.

Examples:

```
CARD.READER NAME = CARDS, DEVICE = CARD.READER;
SYSIN NAME = USER1/1400/OBJECT, DEVICE = DISK;
CARD.READER PACK.ID = USER1;
```

LINE PRINTER DECLARATION

The line printer declaration can specify the B 1000 backup status, the B 1000 printer label type, and the desired B 1000 line printer.

Syntax:

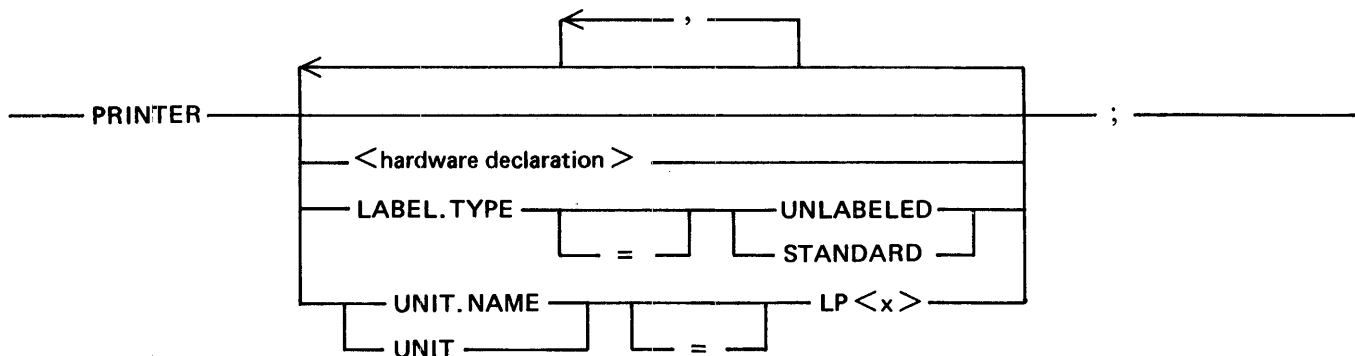

G12354

The <hardware declaration> is described under Hardware Declaration in this section.

The LABEL.TYPE of STANDARD means to print a B 1000 label page at the beginning and at the end of the 1400 line printer output. LABEL.TYPE of UNLABELED suppresses the B 1000 label. The default is STANDARD.

UNIT.NAME or UNIT specifies the desired B 1000 line printer to use (such as LPA). The <x> is the B 1000 unit letter.

Example:

```
PRINTER LABEL.TYPE = STANDARD, UNIT.NAME = LPA;
```

CARD PUNCH DECLARATION

The card punch declaration specifies the B 1000 backup status, the B 1000 label card name, the desired B 1000 device, and the desired B 1000 unit, for the 1400 card punch files.

Syntax:

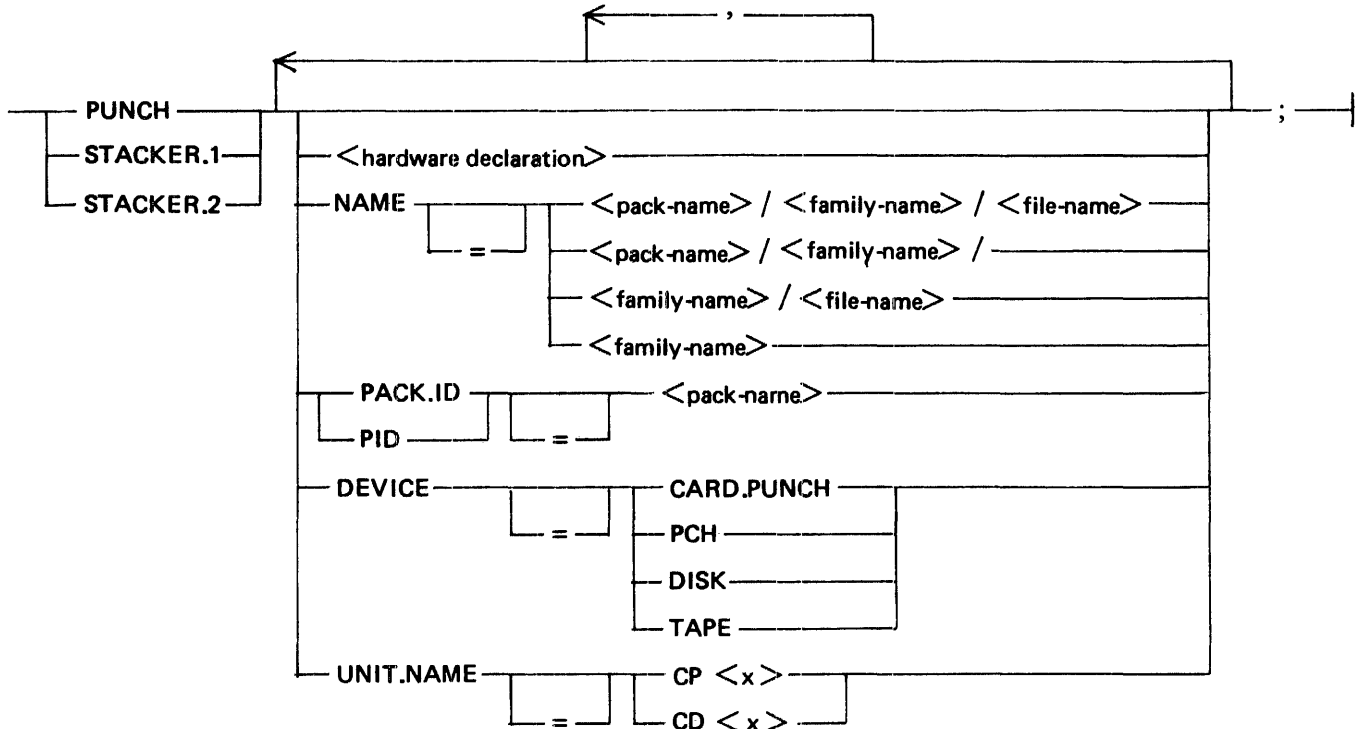

G12355

PUNCH specifies the 1400 card punch used with the 1400 card punch operands. STACKER.1 and STACKER.2 specify B 1000 card punch files for the specific cards that are stacker selected during 1400 card read operations. The input card file is unaffected by 1400 stacker selection. The 1400 stacker select operands for card read operations are ignored if STACKER.1 or STACKER.2 are not specified. Stacker selection on 1400 card punching is handled by the actual B 1000 card punch.

The <hardware declaration> is described under Hardware Declaration in this section.

The NAME specifies the B 1000 file name of the 1400 card punch file. If the 1400 card punch is to be a B 1000 card punch, the name is punched on the B 1000 label (DATA) card that precedes the card deck. The card deck is terminated by a B 1000 END card. If the 1400 card punch is to be a B 1000 disk file (not a backup punch file), the name is the B 1000 disk file name. The default name is CARDS.1400.

When the 1400 card punch is to be a B 1000 disk file, the PACK.ID or PID may be used to specify the B 1000 user pack identification.

The DEVICE specifies the B 1000 device for the 1400 card file. CARD.PUNCH or PCH specifies a B 1000 card punch. DISK specifies a B 1000 disk file. TAPE specifies a B 1000 tape file. DISK or TAPE specify a B 1000 disk or tape file, not a backup punch file. The default is a B 1000 card punch (card punch backup for STACKER.1 and STACKER.2).

UNIT.NAME or UNIT specifies the desired B 1000 card punch, such as CPA or CDA. CP<x> specifies a B 1000 card punch. CD<x> specifies a B 1000 multifunction card unit. The <x> is the B 1000 unit letter.

Examples:

PUNCH NAME = USER/1400/OUTPUT, DEVICE = DISK;

PUNCH NAME = CARDS.1400, DEVICE = CARD.PUNCH, UNIT.NAME = CPA;

HARDWARE DECLARATION

The hardware declaration specifies the backup status and forms option of the line printer or card punch file.

Syntax:

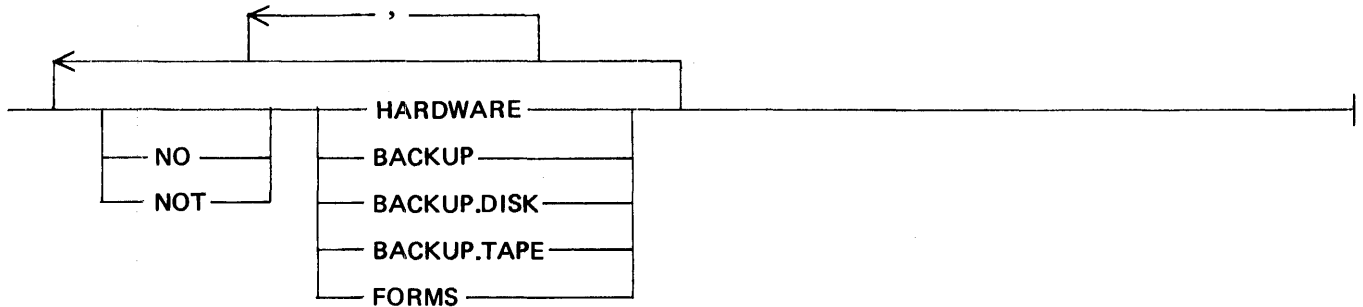

G12356

Specifying **HARDWARE** allows the output to go to the line printer or card punch automatically if a line printer or card punch is available.

Specifying **BACKUP** allows the file to go to the B 1000 line printer or card punch backup disk or tape.

Specifying **BACKUP.DISK** allows the file, if backup, to be sent to disk. Specifying **BACKUP.TAPE** allows the file, if backup, to be sent to tape.

Specifying **FORMS** causes the printing or punching of the output to follow operator intervention, allowing special forms to be mounted on the line printer or the card punch.

A **NO** or **NOT** before any option negates that option. For example, **NO HARDWARE** prevents printing or punching of the file, causing it to go to backup only.

The default is set to **HARDWARE**, **NOT BACKUP**, and **NOT FORMS**.

Examples:

PRINTER **HARDWARE**, **NO BACKUP**;

PUNCH DEVICE = CARD.PUNCH, **NO HARDWARE**, **BACKUP.DISK**;

DISK DECLARATION

The disk declaration is used to specify each IBM 1311 disk drive attached to the 1400 system. If the IBM 1311 disk drive is not specified, it is assumed not to exist on the emulated 1400 system. Each IBM 1311 drive is considered to be a B 1000 disk file by the B 1000 MCP, and is handled as such. The specifications in the disk declaration pertain to the way the B 1000 MCP handles the file and the B 1000 file-name.

Syntax:

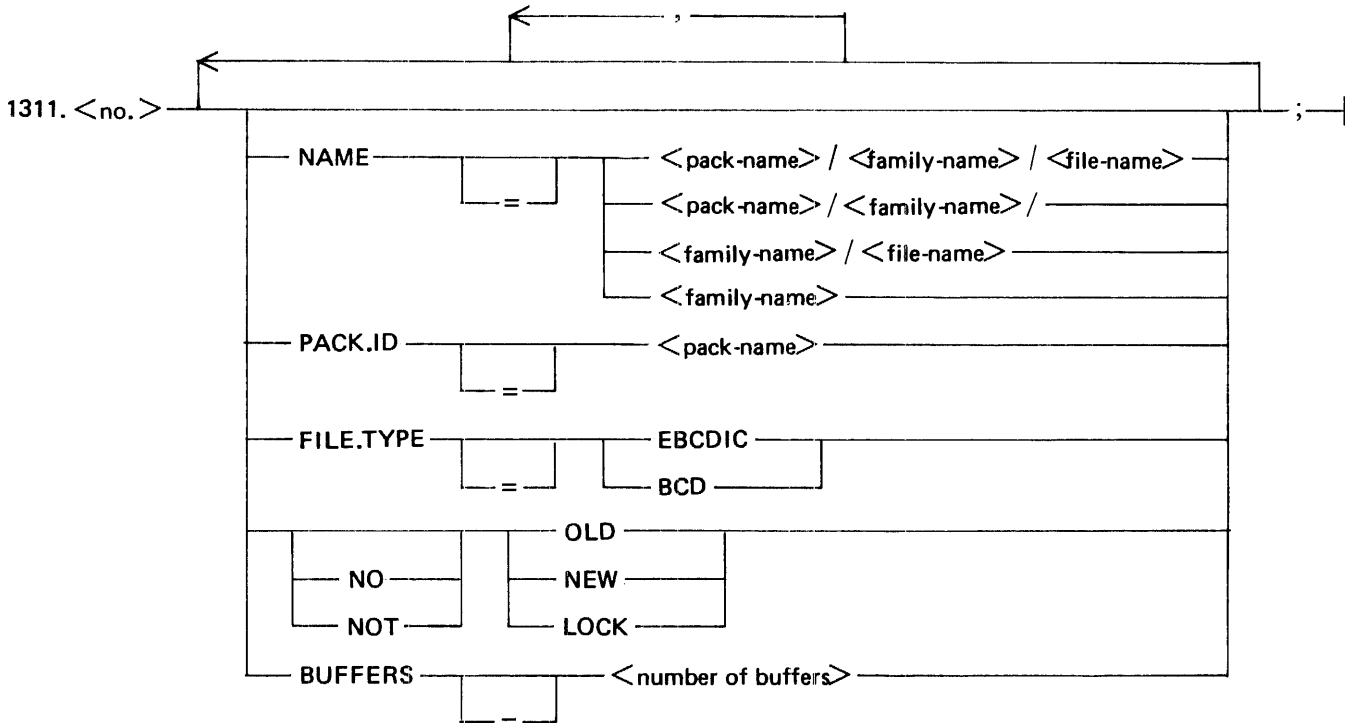

G12357

The <no.> in the 1311.<no.> is either 0, 2, 4, 6, or 8 which represents the IBM 1311 disk drive as specified by the first digit of the 1311 address.

The NAME specifies the B 1000 file-name of the IBM 1311 drive. The default B 1000 file-name is 1400/1311.<no.> where <no.> is either 0, 2, 4, 6, or 8, representing the 1311 number.

The PACK.ID may be used to specify the B 1000 user pack name for the B 1000 file.

FILE.TYPE specifies the type of B 1000 file. EBCDIC is the default, and specifies that the 1400 data is stored on the B 1000 disk as 8-bit EBCDIC characters. BCD specifies that the 1400 data is stored as 6-bit BCD characters. A character conversion is necessary when reading or writing BCD files, so accessing BCD files is somewhat slower. BCD files are used when compatibility between the 1400 Interpreter and the B 1700 free-standing 1400 Emulator is desired. However, BCD files must first be created before they can be used by either the B 1700 free-standing 1400 Emulator, or with the 1400/CREATE1311 program (see Section 6). After creation, the file must be initialized in the IBM 1311 disk format. An error message is produced from the 1400 Interpreter if the 1400 Interpreter attempts to access a 1311 disk file that is not in the correct format.

The B 1000 disk file is, by default, considered an OLD (already on B 1000 disk) file by the B 1000 MCP. Specifying NEW causes a new file to be created. If LOCK and NEW are specified, the new file is saved after the 1400 environment has gone to a B 1000 end of job. A NO or NOT preceding the NEW, OLD, or LOCK causes the opposite of that action. OLD, NEW, and LOCK are used only if the FILE.TYPE is EBCDIC.

The BUFFER specification indicates how many B 1000 I/O buffers to allocate to the B 1000 disk file. Specifying <number of buffers> causes the B 1000 MCP to allocate that number of I/O buffers to the disk file. Specifying more buffers may increase the execution speed of 1400 programs, but it does require additional B 1000 memory for the buffers. The <number of buffers> can be from 1 to 15. The default is 1.

An IBM 1311 disk drive is regarded as a random disk file by the B 1000 MCP. The B 1000 file has a B 1000 record size of 108 characters (90 characters if FILE.TYPE is BCD), with 10 records per block. The B 1000 file has 100 blocks per area, with 10 areas. Each B 1000 record consists of a verification flag (verifies that this is a 1311 disk file), a 6-digit 1400 IBM 1311 disk address, an indicator to indicate whether this sector is a 1400 MOVE MODE or LOAD MODE sector, and 100 characters (90 characters if LOAD MODE) of 1400 data. One B 1000 record is equivalent to one 1400 IBM 1311 disk sector. The 1400 disk address is used as the random key into the B 1000 disk file.

Before the 1311 disk can be used by 1400 programs, it must be initialized in the IBM 1311 disk format with either the IBM CLEARDISK program executed by the 1400 Interpreter, or with the options available with the 1400/CREATE1311 program. Refer to Section 6 for details on the 1400/CREATE1311 program. When running the 1400 CLEARDISK program, the appropriate 1311 disk keys must be set. Refer to the Set/Reset Disk Keys (ON) command in Section 4.

Examples:

1311.0 NAME = USER/1400/1311.0, OLD, BUFFERS = 5;

1311.4 NAME = USER/A/B, NEW, LOCK, FILE.TYPE = EBCDIC, BUFFERS = 3;

TAPE DECLARATION

The tape declaration is used to specify each 1400 tape drive that is attached to the 1400 system. If the 1400 tape drive is not specified, it is assumed not to exist on the emulated 1400 system.

Syntax:

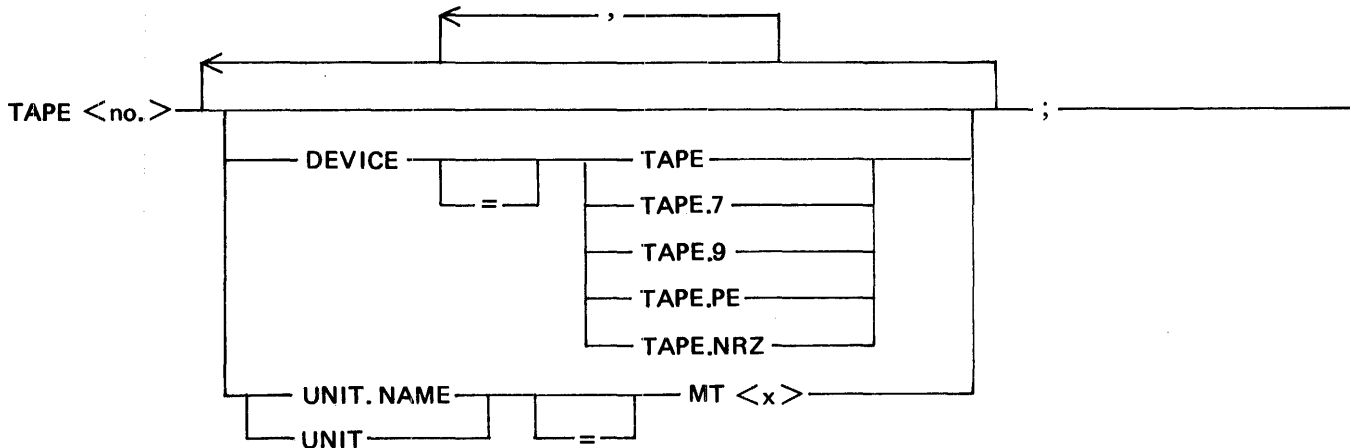

The <no.> in TAPE<no.> is a digit from 1 to 6 that represents the 1400 tape drive, as specified in the 1400 tape operand.

DEVICE indicates which type of B 1000 tape drive is requested: 7-track (TAPE.7), 9-track (TAPE.9), 9-track NRZ (TAPE.NRZ), 9-track PE (TAPE.PE), or any type of tape (TAPE). The default is any type of tape. 1400 tape files must be on tape on the B 1000 system; they cannot be file-equated to B 1000 disk or any other type of B 1000 device.

UNIT.NAME or UNIT specifies which B 1000 tape drive to use (such as MTA). The <x> is the B 1000 unit letter. The DEVICE specification is ignored if UNIT.NAME is specified. If UNIT.NAME is omitted, a scratch tape on a valid tape device (such as a 9-track tape if the DEVICE is specified as TAPE.9) is used. If a scratch tape cannot be found, the B 1000 MCP asks the B 1000 system operator for an assignment to a tape drive. A discussion of tape assignment by means of the B 1000 messages UL or OU, or by the MODIFY, EXECUTE, and DYNAMIC statements can be found in Section 5 under Tape Assignment.

Example:

```
TAPE1 DEVICE = TAPE.7, UNIT.NAME = MTB;
```

CONSOLE DECLARATION

The console declaration is used to declare that a supervisory console is attached to the 1400 system, and to specify its type, either 1407 or 1447. The default is 1407.

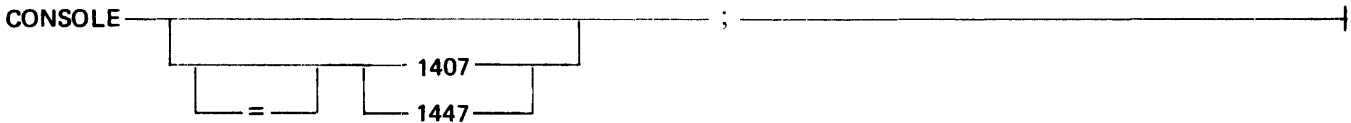

G12359

Examples:

```
CONSOLE;  
CONSOLE = 1447;
```

OPTIONAL DECLARATIONS

Optional declarations are for specifying special 1400 Interpreter options.

Syntax:

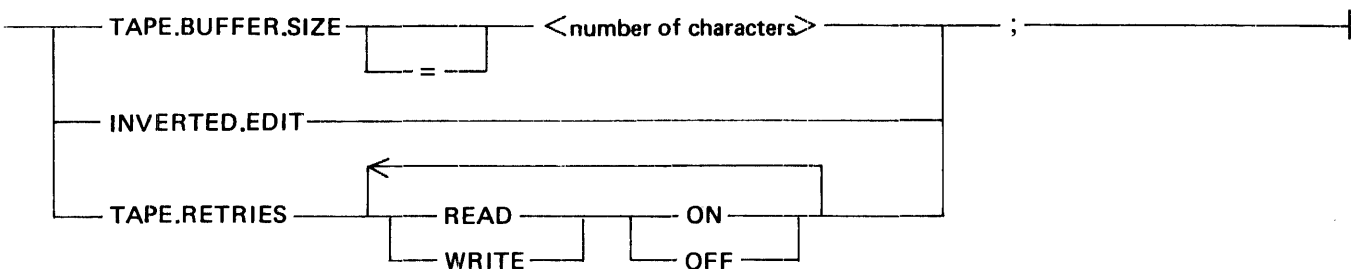

G12360

The TAPE.BUFFER.SIZE option specifies the number of characters of the largest 1400 tape block to be read or written (odd or even parity, and load mode). The <number of characters> is a number from 0 to 32000, and represents the tape buffer size in characters. If the tape buffer is too small, the 1400 Interpreter is not able to execute the 1400 tape instruction. Specifying too large a tape buffer wastes memory on the B 1000 system. If a tape buffer size is not specified and tape drives are included in the environment, the TAPE.BUFFER.SIZE is set to 4000 characters.

INVERTED.EDIT indicates that the 1400 edit instruction is to use the international edit format.

The TAPE.RETRIES option indicates how 1400 tape errors are to be handled. TAPE.RETRIES is separated into two classes of 1400 tape operands: READ and WRITE. READ specifies all 1400 tape read operands. WRITE specifies all 1400 tape write operands. ON specifies that tape retry is to be handled by the B 1000 MCP, and OFF specifies that the 1400 program is to handle the error (the 1400 tape error branch is taken). If ON is specified and the B 1000 MCP is unable to correct the tape error, the environment is abnormally terminated (DS-ed) by the B 1000 MCP. The default is OFF for READ and ON for WRITE.

Examples:

```
TAPE.BUFFER.SIZE = 4000;  
INVERTED.EDIT;  
TAPE.RETRIES READ OFF WRITE ON;
```

COMPILATION

The 1400/IEP creates an environment file using the standard B 1000 compiler control statements plus the specification statements. Normally, this file contains the following statements: COMPILE, DATA, the specifications, and END. The COMPILE statement may be entered on the B 1000 ODT or on a card with an invalid character punched in column 1. The DATA statement normally follows the COMPILE statement, and the DATA and the END statement must have invalid character punches in column 1.

The following is an example of a compile deck for a 1400 Interpreter environment called 1400/TEST. The 1400/TEST environment has 16K of memory, a line printer, a card punch, and a 1311 disk drive. It is desirable to create this environment on B 1000 disk (to library) for later execution.

```
?CO 1400/TEST WITH 1400/IEP TO LIBRARY  
?DATA CARDS  
MEMORY.SIZE = 16K;  
PRINTER;  
PUNCH;  
1311.0;  
FINI;  
?END
```

The specification file may be a disk file that is file-equated at compile time. This may be accomplished by entering the following statement:

```
?CO 1400/TEST WITH 1400/IEP TO LIBRARY  
?FILE CARDS NAME <disk-file-name> DISK;
```

The specifications may be made through B 1000 ACCEPT messages on the B 1000 operator display terminal (ODT), by setting program switch 0 of the 1400/IEP at the beginning of job.

Example:

```
?CO 1400/TEST WITH 1400/IEP TO LIBRARY; SW 0 = 1
 1400/IEP : 1400/TEST = 1234 BOJ ...
 1400/IEP : 1400/TEST = 1234 ACCEPT.
1234AXMEMORY.SIZE = 16K;
1234AXPRINTER;
1234AXPUNCH;
1234AX1311.0;
1234AXFINI;
```

The COMPILE statement designates the type of compilation to be performed. The format of the COMPILE statement is:

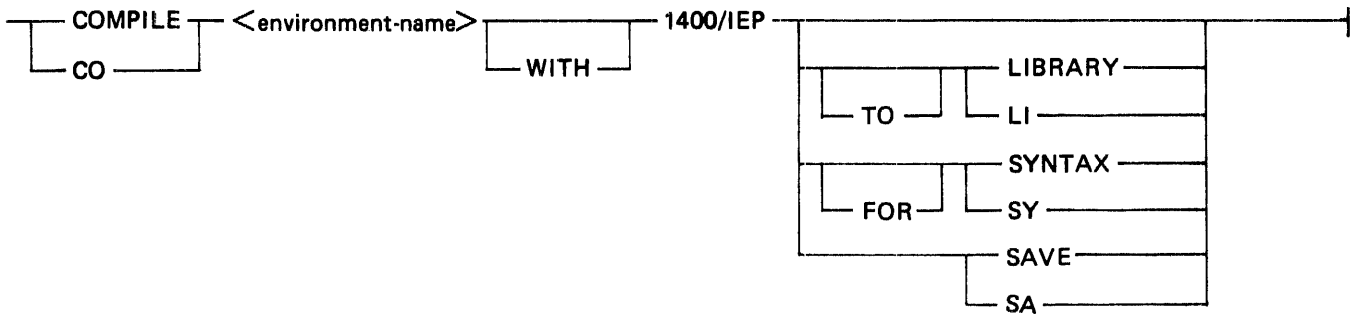

G12361

The COMPILE statement has four options: COMPILE, COMPILE TO LIBRARY, COMPILE SAVE, and COMPILE FOR SYNTAX.

The COMPILE option is for a “compile and go” operation. If the specifications are error-free, the B 1000 MCP schedules the environment for execution. The <environment-name> is not entered into the B 1000 disk directory, and must be recompiled to be used again. The “compile and go” is the default option of the COMPILE statement.

The COMPILE TO LIBRARY option leaves the environment on disk and enters the <environment-name> into the B 1000 disk directory for later execution, if there are no errors in the specifications.

The COMPILE SAVE option combines the execute and LIBRARY options. If there are no errors in the specifications, the B 1000 MCP enters the <environment-name> into the B 1000 disk directory and leaves the environment on disk. It also schedules the environment for execution. The environment remains on the B 1000 disk.

The COMPILE FOR SYNTAX option provides a diagnostic listing as the only output. This option does not enter the <environment-name> into the B 1000 disk directory or leave the environment on disk. It is used primarily as a debugging tool, for a first-time compilation, or for a new source listing.

To execute the environment file after it has been compiled to library, the B 1000 EXECUTE control statement is entered on either the B 1000 ODT or on a card with an invalid character punched in column 1. The format of the EXECUTE statement is:



G12362

For further information on the COMPILE and EXECUTE statements, refer to the B 1000 Systems System Software Operation Guide, Volume 1, form number 1108982.

SECTION 4 INTERPRETER OPERATION

1400 INTERPRETER COMMANDS

Through the B 1000 operator display terminal, the user can send commands to the 1400 environment in order to emulate 1400 console control functions, to modify 1400 programs, or to send data to 1400 programs.

The commands sent through the operator display terminal use the standard MCP ACCEPT command. For a complete discussion of the MCP ACCEPT command, refer to the B 1000 Systems System Software Operation Guide, Volume 1, form number 1108982. The 1400 environment command and format is shown in this section using railroad diagrams. The syntax consists of the B 1000 job number (<job-number>), followed by AX, followed by the command and any parameters to the command. Embedded blanks must separate the command and any parameters. Only the first three letters of the command are examined, and successive characters following the first three are ignored, until the first blank. After the first blank following the command, the accept message is scanned for any parameters to the command. The maximum length of the accept message is 72 characters.

The ALTER, DISPLAY, and SET commands are used to alter or display 1400 memory. A 1400 character with a wordmark is indicated by a wordmark indicator preceding the 1400 character with the wordmark. The wordmark indicator varies with the type of B 1000 operator display terminal. A B 9340 (teletype) ODT uses the "up arrow." A B 9348-1 (TD801) ODT uses the "not equal" sign. The B 9348-31, B 9348-32, and B 9348-52 (TD831, TD851) ODTs use the "caret" symbol.

In the command examples given in the following section, it is assumed that the environment name is A/B and the B 1000 environment job number is 1234.

?

SEND CONSOLE PRINTER DATA TO 1400 PROGRAM

Syntax:

<job-number> AX—— ? <message>—————|

G12363

Function:

The ? command is used to send console printer data to 1400 programs. This command also sets the 1400 inquiry indicator (for Branch on Inquiry). The entire <message> field is sent to the 1400 program on the next occurrence of a 1400 read console operation. The message may be entered before it is requested. A subsequent ? command without an intervening 1400 read console operation overwrites the previous message. The <message> field may be up to 71 characters in length, and must immediately follow after the question mark with no embedded blanks.

NOTE

The ? separates messages directed to the user program as opposed to messages directed to the 1400 Interpreter.

Example:

1234AX?THIS IS A 1400 PROGRAM MESSAGE

ALTER

ALTER 1400 MEMORY

Syntax:

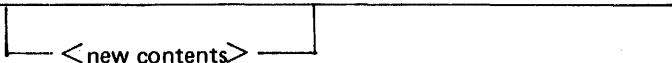
<job-number> AX ALTER <3-char address> 

G12364

Function:

The ALTER command is used to write the <new contents> at the 1400 memory location beginning at the <3-char addr>. The <3-char addr> is a 1400 3-character machine address. All leading blanks occurring in the <new contents> field are ignored.

After performing the ALTER command, the 1400 Interpreter displays 25 characters of the contents of 1400 memory, beginning at the given <3-char addr>. If the <new contents> field is omitted, 1400 memory is not altered, but memory is displayed.

The 1400 characters with wordmarks are preceded by the wordmark indicator. A wordmark indicator should not be entered without a succeeding character.

Example:

```
1234AXALT A00 NEW MEMORY CONTENTS
```

CLEAR

CLEAR 1400 CONSOLE PRINTER

Syntax:

<job-number> AX ——— CLEAR —————|

G12385

Function:

The CLEAR command is used to emulate the CLEAR button on the 1400 console printer. This command clears the unused 1400 console printer message if used when the 1400 program is not performing a console Read operation. When the 1400 program is attempting a console Read operation, the CLEAR command causes the Read to be ignored, and 1400 processing continues with the next 1400 instruction. The CLEAR command resets the 1400 inquiry indicator and sets the 1400 clear indicator.

Example:

1234AXCLE

DISPLAY

DISPLAY 1400 MEMORY

Syntax:

<job-number> AX ——— DISPLAY <3-char address> —————

G12366

Function:

The DISPLAY command is used to display 25 characters of the contents of 1400 memory beginning at the given <3-char address>. The <3-char address> is a 1400 3-character machine address. A wordmark in a location is displayed as a wordmark indicator preceding the character contained in that location.

Example:

1234AXDIS A00

DUMP

DUMP 1400 MEMORY

Syntax:

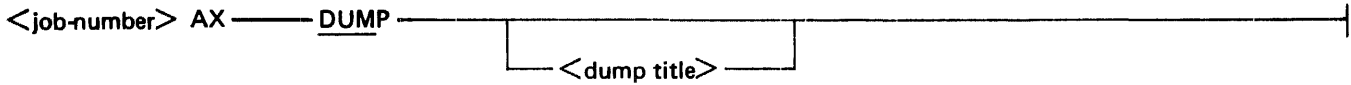

G12387

Function:

The DUMP command is used to print the contents of 1400 memory on the line printer. The printout consists of a line containing the <dump title>, if <dump title> is specified, followed by a line which contains:

1. The instruction address register in decimal and 1400 machine code.
2. The next instruction to be executed.
3. The A and B registers in 1400 machine code.
4. The sense switch settings.
5. The arithmetic condition indicator (<, =, >).
6. The overflow indicator (OV if set, otherwise blank).
7. The index registers X1, X2, and X3 in 1400 machine code.
8. The contents of 1400 memory locations pointed to by the A and B registers (asterisks if the corresponding register is not a valid 1400 address).

The 1400 memory dump follows. If 100 or more consecutive memory locations are blank, the printing of the corresponding line is suppressed.

Example:

1234AXDUM MEMORY DUMP AT 1600 HOURS

END

END 1400 PROGRAM

Syntax:

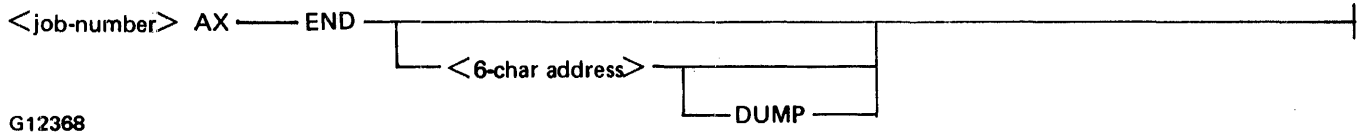

Function:

The END command is used to terminate a 1400 program. When only END is specified, 1400 processing stops temporarily while the next 1400 program is loaded. This is equivalent to using the LOAD command.

The <6-char address> consists of two 3-character 1400 machine addresses. When the <6-char address> is specified, the END occurs automatically provided the following is true:

1. The A register equals the leftmost three characters of the <6-char address>.
2. The B register equals the rightmost three characters of the <6-char address>.
3. A 1400 halt instruction is executed.

If DUMP is specified, a 1400 memory dump is printed when the END occurs.

Examples:

```
1234AXEND  
1234AXEND 999999  
1234AXEND 999999 DUMP
```

EOF

CLOSE B 1000 FILE

Format:

<job-number> AX — EOF <mnemonic> —————

G12369

Function:

The EOF command is used to free the B 1000 device specified by <mnemonic> for use by another B 1000 program. The EOF command generates a B 1000 file close operation on the file. The EOF command is useful when multiprogramming 1400 environments with other B 1000 jobs or other 1400 environments which require the B 1000 peripheral devices in use by the environment. An EOF on the B 1000 card reader requires the use of a B 1000 DATA card to re-establish that card reader as a device to be used by that 1400 environment.

The EOF command can also be used to simulate the exchanging of 1311 disk packs. Refer to Section 5 for details.

The following devices may be freed by the EOF command:

| Device | Mnemonic |
|-------------|---------------------------------|
| CARD.READER | CRD |
| PUNCH | PCH |
| PRINTER | PRT |
| 1311.# | DK# where # is 0, 2, 4, 6, or 8 |
| TAPE# | TP# where # is 1 through 6 |

Examples:

```
1234AXEOF CRD
1234AXEOF DK8
1234AXEOF TP6
```

EOJ

TERMINATE

Syntax:

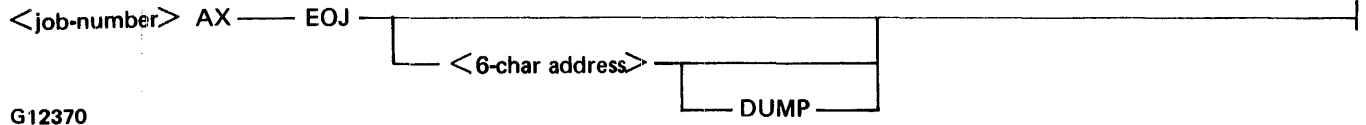

Function:

The EOJ command is used to terminate the 1400 environment. If EOJ alone is specified, the environment goes to B 1000 end of job immediately.

The <6-char address> consists of two 3-character 1400 machine addresses. When it is specified, the environment goes to B 1000 end of job if all of the following are true:

1. The A register equals the leftmost three characters of the <6-char address>.
2. The B register equals the rightmost three characters of the <6-char address>.
3. A 1400 halt instruction is executed.

If DUMP also is specified, a 1400 memory dump is printed just before B 1000 end of job.

Examples:

```
1234AXEOJ
1234AXEOJ 999999
1234AXEOJ 999999 DUMP
```

EQUALS

1400 ADDRESS CONVERSION

Syntax:

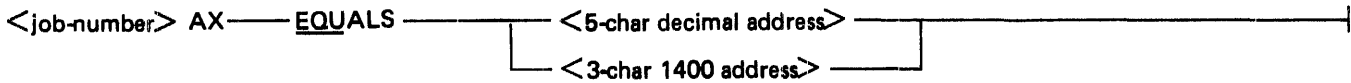

G12371

Function:

The EQUALS command is used to convert 5-digit 1400 decimal memory addresses to 3-digit 1400 machine addresses, or the opposite. The command accepts either a 5-digit decimal address or a 3-digit 1400 machine address and then displays the opposite.

Examples:

```
1234AXEQU 03100
  % A/B = 1234 03100 = A00
1234AXEQU A00
  % A/B = 1234 A00 = 03100
```

LOAD

LOAD 1400 PROGRAM

Syntax:

<job-number> AX — LOAD —————
 └─ TAPE ─┘

G12372

Function:

The **LOAD** command is used to emulate the **LOAD** button on the 1400 card reader. This command causes a card to be read, loaded to 1400 memory location 001, a word mark to be placed at 001, and control to be transferred to location 001.

The 1400 program should be self-loading or the 1400 Interpreter flushes the deck of cards until self-loading is evident (the first three columns equal to “,00”), or until the end of the deck is reached.

LOAD TAPE emulates the **TAPE LOAD** button on the 1400 console. The 1400 Interpreter clears 1400 memory, loads the first record from the **TAPE1** drive at 1400 memory location 001, sets a word mark at 1400 memory location 001, and transfers control to 001. The tape is read in the load mode, even parity.

Examples:

```
1234AXLOA  
1234AXLOA TAP
```

OK

CONTINUE 1400 PROCESSING

Syntax:

<job-number> AX ——— OK —————|

G12373

Function:

The OK command is used to emulate the START button on the 1400 console. This command starts 1400 processing at the current value of the 1400 instruction address register. If the 1400 Interpreter is in the single-step mode, only the current instruction is executed. This command is identical to the START command.

Example:

1234AXOK

ON or OFF

SET/RESET DISK KEYS

Syntax:

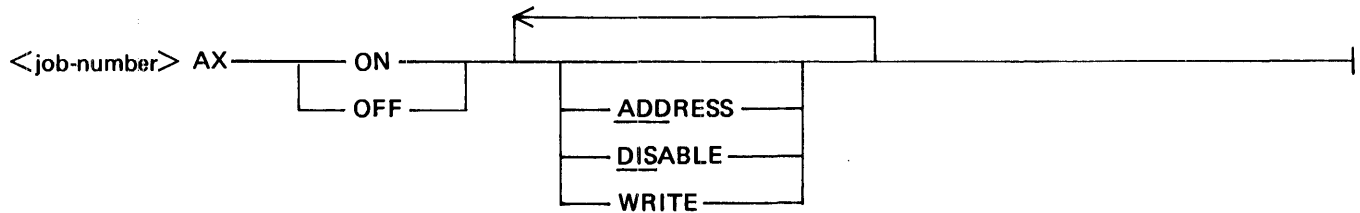

G12374

Function:

The ON and OFF commands are used to set or reset the 1400 IBM 1311 disk keys. ADDRESS refers to the 1400 write address key, which when ON, allows writing of 1400 IBM 1311 disk addresses with the 1400 write disk address operands. DISABLE refers to the 1400 disable disk address compare key which, when ON, suppresses the 1400 disk address comparison logic. WRITE refers to the 1400 Write Disk Switch which, when ON, allows 1400 disk writing to be performed. The default key setting is ON for WRITE, and OFF for DISABLE and ADDRESS. After performing the command, the 1400 Interpreter displays the keys that are ON. Specifying only ON or OFF causes the 1400 Interpreter to display the keys that are ON. The 1400 disk error indicators (Y, X, W, V, N, and /) also are displayed if they are ON.

When running the IBM CLEARDISK program for the first time against a newly created B 1000 file, the ADDRESS, DISABLE, and WRITE keys are normally set ON. After running the CLEARDISK program, the DISABLE and ADDRESS keys are normally set OFF.

Examples:

```
1234AXON
1234AXON DIS ADD WRI
1234AXOFF ADD DIS
```

REGULAR

RESUME REGULAR MODE

Syntax:

<job-number> AX — REGULAR —————|

G12375

Function:

The REGULAR command is used to switch from the single-step processing mode to the normal processing mode. To resume 1400 processing, the START or OK commands must be used.

Example:

1234AXREG

RESET

RESET 1400 PROCESSOR

Syntax:

<job-number> AX — RESET ————— |

G12376

Function:

The RESET command is used to emulate the START/RESET button on the 1400 console. Specification of this command causes all 1400 indicator flags to be cleared, except the 1400 comparison indicators and the 1400 sense switches. The 1400 OP code and instruction length registers are cleared also. The contents of 1400 memory or the address registers are not affected (except the branch address of a 1400 halt and branch type of halt, in which the instruction address register is set to the next sequential instruction after the halt instruction).

Example:

1234AXRES

RUN

RESTART 1400 PROCESSING

Syntax:

<job-number> AX—— RUN —————|

G12377

Function:

The RUN command performs the combined functions of the REGULAR and START commands. It causes 1400 processing to be resumed at the current value of the 1400 instruction address register. If the 1400 Interpreter is in the single-step mode, the normal mode is resumed. This instruction can also be used to reset the STOP address (refer to Stop 1400 Processing in this section).

Example:

1234AXRUN

SET

SET 1400 MEMORY TO A CHARACTER

Syntax:

<job-number> AX SET _____
 └─┬─┘
 <character>

G12378

Function:

The SET command is used to set all 1400 memory to the character contained in the <character> field. If more than one character is entered, the first character is used. A blank cannot be entered directly, but memory is set to blanks if the <character> field is omitted. Memory can be set to a character with a wordmark by entering a wordmark indicator preceding the character.

Examples:

1234AXSET
1234AXSET N

SINGLE

BEGIN SINGLE STEP MODE

Syntax:

<job-number> AX SINGLE _____|

G12379

Function:

The SINGLE command is used to switch to the single-step execution mode on the 1400. The 1400 Interpreter stops after executing each 1400 operand. To execute the next 1400 operand, the START or OK commands are used. To resume the normal mode of execution, the REGULAR or RUN commands are used.

Example:

1234AXSIN

START

START 1400 PROCESSING

Syntax:

<job-number> AX—START—————|

G12380

Function:

The START command is used to emulate the START button on the 1400 console. This command starts 1400 processing at the current value of the 1400 instruction address register. If the 1400 Interpreter is in the single-step mode, only the current instruction is executed. This command is identical to the OK command.

Example:

1234AXSTA

STOP

STOP 1400 PROCESSING

Syntax:

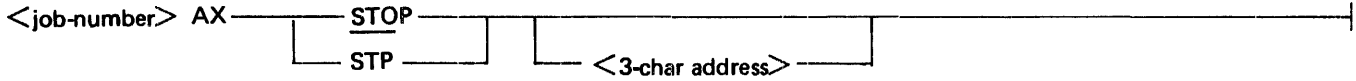

G12381

Function:

The STOP command is used to emulate the STOP button on the 1400 console. If the <3-char addr> is omitted, the command causes 1400 processing to halt following execution of the current 1400 instruction.

If the <3-char addr> is specified, the 1400 Interpreter stops 1400 processing when the 1400 instruction address register is equal to the <3-char addr>. To cancel the halt address, a STOP command without the halt address is given, or the RUN command is used. A STOP command with the halt address may be specified before or during execution of the 1400 program.

Examples:

```
1234AXSTP  
1234AXSTO I9R
```

SET 1400 SENSE SWITCHES

Syntax:

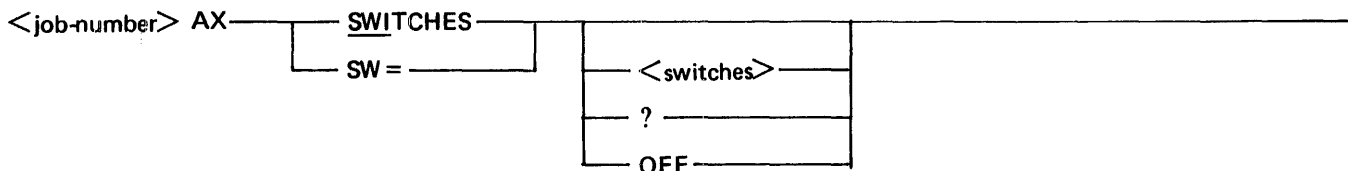

G12382

Function:

The SWITCHES command is used to set or display the 1400 sense switch settings. The sense switches that are on are displayed in alphabetical order.

When the <switches> field is omitted or ? is entered, the sense switches that are on are displayed.

If OFF is specified, all switches are reset.

The <switches> field contains the switches that are to be set, in any order. All switches not specified in the field are reset.

Examples:

```
1234AXSWI ABDF
1234AXSWI ?
1234AXSW = OFF
```

TRANSFER

TRANSFER TO 1400 MEMORY LOCATION

Syntax:

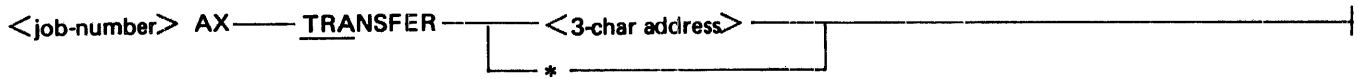

G12383

Function:

The TRANSFER command is used to alter the 1400 instruction address register to the <3-char address> 1400 machine address, and to begin 1400 processing. If the <3-char address> given is a single asterisk (*), execution begins at the current value of the 1400 instruction address register.

Examples:

1234AXTRA A00
1234AXTRA *

INQUIRE STATUS

Syntax:

<job-number> AX—— WY—————|

G12384

Function:

The WY command displays the current state of the 1400 machine, the current values of the 1400 instruction address register, the current 1400 instruction, and the A and B registers.

Since the 1400 Interpreter is designed to multiprogram, it is sometimes difficult to know what the 1400 Interpreter is doing at any particular time. Without interrupting the 1400 processing, the current status of the 1400 machine can be interrogated.

Examples:

1234AXWY

% A/B = 1234 *** AX DS WAITING FOR KEYBOARD INPUT

% A/B = 1234 IAR = 00500 (500) OP = B400 A = 400 B = 504

1234AXWY

% A/B = 1234 PROGRAM EXECUTING

% A/B = 1234 IAR = 00400 (400) OP = 2 A = 400 B = 333

COMMENT

OPERATOR DISPLAY TERMINAL COMMENT

Syntax:

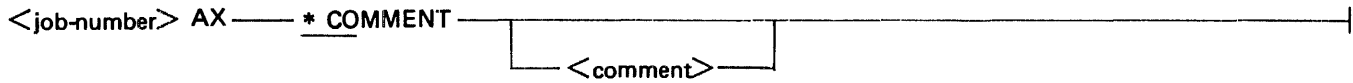

G12385

Function:

The *COMMENT command is used to enter a comment on the B 1000 operator display terminal. The command is ignored by the 1400 Interpreter. The *COMMENT command may be specified at any time. The *COMMENT command may be used with the INTOPT cards (refer to INTOPT in this section) to display comments on the B 1000 operator display terminal.

Examples:

1234AX*CO THIS IS A COMMENT

LINE PRINTER COMMENT

Syntax:

<job-number> AX *** _____
 └───┬───┘
 <comment>

G12386

Function:

This command is used to print a comment line on the 1400 printer output. The three asterisks (***) are printed with the <comment> on the listing so that the comment can be discerned from normal 1400 program output. This command may be specified at any time.

Example:

1234AX*** THIS IS A COMMENT

INTOPT

INTOPT cards are used to minimize 1400 Interpreter program/operator intervention. INTOPT cards allow the specification of necessary 1400 Interpreter commands on cards at the beginning of the program deck.

1400 Interpreter commands that are invalid from INTOPT cards are LOAD and WY. A LOAD command must have been entered to begin reading the card file with the INTOPT cards. LOAD TAPE is acceptable, however. WY must not be entered because fields normally displayed are meaningless while processing INTOPT cards.

All the other 1400 Interpreter commands can be used with INTOPT cards. The syntax of the INTOPT card is as follows:



INTOPT may be in any location on the input card. A colon (:) is used to separate INTOPT entries. The “not sign” is used for the wordmark indicator in the ALTER or SET commands.

Special INTOPT options follow:

| <Command> | Function |
|---------------|---|
| INVERTED.EDIT | Switch the 1400 edit command to the international style of editing. |
| SYSIN | Start reading from the SYSIN input deck. |
| RCB.ALLOWED | Allow 1400 read column binary. |

SYSIN and RCB.ALLOWED cannot be used together. If either SYSIN or RCB.ALLOWED is used, it must be the last INTOPT command specified. Refer to the SYSINT INTOPT Option and 1400 Read Column Binary in this section for details.

Examples:

```
INTOPT *COMMENT THIS IS PROGRAM ABC
INTOPT SWI ACD : EOJ 999999
INTOPT LOAD TAPE
```

SYSIN INTOPT OPTION

The SYSIN INTOPT option is used to temporarily stop reading the input card deck, and to start reading from the B 1000 SYSIN file. When the SYSIN file has been completely read, card reading resumes with the normal input deck. This can be used when an object program card deck is on B 1000 disk, and data is on cards. By using B 1000 file equation cards and INTOPT cards, the object program can be read from disk, as shown in the following example.

```
?EX A/B  
?FILE SYSIN NAME <1400 object program file name>;  
?DATA CARDS.1400  
INTOPT SYSIN  
  
    <1400 data >  
  
?END
```

The preceding example causes the cards in the object program file to be read before the cards in the data deck.

The SYSIN INTOPT card must be the last INTOPT card in the deck. INTOPT cards are not allowed in the SYSIN file. 1400 read column binary is not allowed when using the SYSIN option.

The SYSIN file name and attributes may be declared in the 1400/IEP specifications. Refer to Card Reader Declaration in Section 3 for additional information.

1400 READ COLUMN BINARY

The RCB.ALLOWED INTOPT option is used when 1400 read column binary is desired. When this INTOPT option is encountered, the B 1000 card file is closed and a new B 1000 binary card file is opened. The name of the B 1000 binary card file is BIN.1401. An example of an execution deck using 1400 read column binary follows:

```
?EX A/B  
?DATA CARDS.1400  
INTOPT RCB.ALLOWED  
?END  
?DATA BIN.1401  
  
    1400 object program and  
    data (binary and EBCDIC)  
  
BIN.END  
?END
```

The binary card deck is terminated by a card with BIN.END starting in column 1, followed by the B 1000 END card. INTOPT cards are not allowed in the binary deck. All desired INTOPT cards should precede the RCB.ALLOWED INTOPT card. The SYSIN INTOPT option is not allowed when using 1400 read column binary. Read column binary decks must be B 1000 80-column card decks; they cannot be file-equated to B 1000 disk or any other B 1000 device.

SECTION 5 MCP INTERFACE

GENERAL

Some of the features and options available through the B 1000 MCP are discussed in this section. These features and options are further discussed in the B 1000 Systems System Software Operation Guide, Volume 1, form number 1108982.

ENVIRONMENT PARAMETER CHANGES

Some specifications made in the 1400 environment can be changed after compilation. These specifications include external B 1000 file-names for the card reader, card punch, and 1311 disks, B 1000 tape unit assignment and device type for the tape files, and the NEW and LOCK functions of the B 1000 disk files. The three B 1000 MCP commands that can change the specifications are the MODIFY, EXECUTE, and DYNAMIC statements. The statements may be entered on the B 1000 operator display terminal or on cards with invalid punches in column one. The statements are formatted as follows:

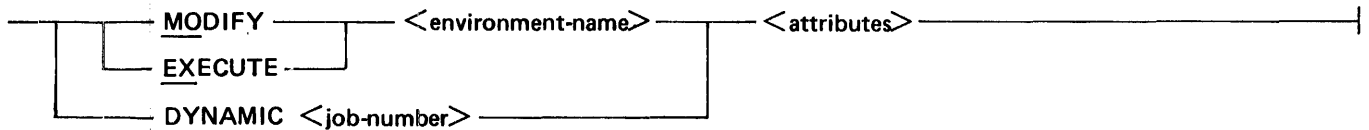

G12388

The MODIFY statement changes the attributes of the <environment-name> specified, but does not affect any environments currently executing with that name. The new attributes are in effect with the next execution, unless subsequently overridden.

The EXECUTE statement executes the environment, and the attributes are in effect for that execution only. These attributes override conflicting attributes in the permanent environment codefile.

The DYNAMIC statement changes the attributes only on the environment specified by the B 1000 job number (<job-number>) associated with its current execution.

Some of the attributes available are specified as follows:

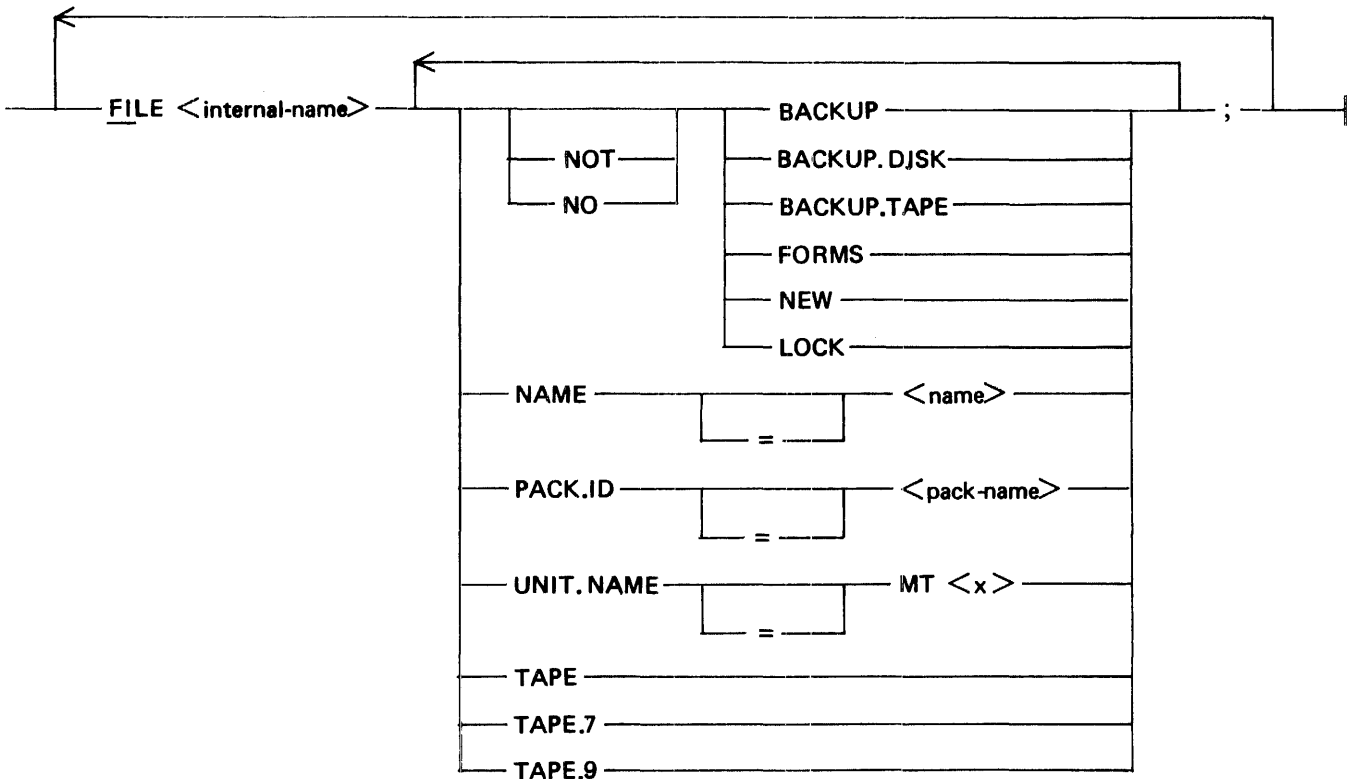

G12389

Subsequent FILE statements may follow, separated by semicolons. The <internal name> of the B 1000 files associated with the environment are as follows:

| 1400/IEP Syntax | Internal Name |
|-----------------|---------------|
| CARD.READER | CARDS |
| SYSIN | SYSIN |
| PUNCH | PUNCH |
| STACKER.1 | STACKER.1 |
| STACKER.2 | STACKER.2 |
| PRINTER | PRINTER |
| 1311.<digit> | 1311.<digit> |
| TAPE<digit> | TAPE<digit> |

The meanings and functions of the parameters of the MCP file statement shown are identical to those of the 1400/IEP specifications. For a more complete discussion of these MCP statements, refer to the B 1000 Systems System Software Operation Guide, Volume 1, form number 1108982.

Examples:

```

FILE SYSIN NAME = USER1/1400/OBJECT;
FILE PRINTER NO HARDWARE;
FILE TAPE1 UNIT.NAME = MTB;

```

TAPE ASSIGNMENT

Tape assignments to B 1000 tape drives can be made in three ways. They can be specified at 1400/IEP compilation time by the typical specification:

```
TAPE1 UNIT.NAME = MTA;
```

Tape assignment can be modified or changed by the MODIFY, EXECUTE, or DYNAMIC statements:

```
EXECUTE A/B FILE TAPE1 UNIT.NAME = MTA;
```

Tape assignment can also be made when the tape drive is actually required, when requested by the B 1000 MCP:

```
A/B = 1234 TAPE UNIT NEEDED FOR TAPE1
```

The operator can then respond with the B 1000 <job-number>UL or <job-number>OU messages:

```
1234ULMTA
```

To change B 1000 tape drives (changing TAPE1 to use MTB instead of MTA) after the environment has been assigned the original B 1000 tape drive, the following command is required.

```
1234AXEOF TP1
```

After entering this command, the tape drive can be reassigned by the DYNAMIC statement, or by the UL message.

To interrogate which B 1000 tape drive is being used by a particular 1400 tape drive, enter the following B 1000 QP MCP command on the B 1000 operator display terminal:

```
QP <job-number> FILE TAPE<digit> UNIT.NAME
```

The B 1000 MCP responds with a message that indicates which B 1000 tape drive the file is assigned to. Multiple file interrogation can be entered with one QP message, separated by semicolons:

```
QP <job-number> FILE TAPE1 UNIT.NAME; FILE TAPE2 UNIT.NAME;
```

DISK ASSIGNMENT

Exchanging of IBM 1311 disk packs can be simulated with the EOF 1400 Interpreter command, and the DY MCP command. The following commands may be used, assuming a user's 1311 pack with a B 1000 file name of "USER/1400/PAYROLL" is to replace the existing 1311 pack on 1311 drive 2:

```
1234AXSTOP  
1234AXEOF DK2  
DY 1234 FILE 1311.2 NAME USER/1400/PAYROLL;  
1234AXSTART
```

It is suggested that the 1400 program be stopped to prevent accidental accessing of the drive to be exchanged. The EOF command is entered before the DY command because the B 1000 MCP requires that files be closed before any name changes can be made.

The first 1400 access of the IBM 1311 disk drive causes a B 1000 file open of the B 1000 disk file.

1400 INSTRUCTION TRACING

1400 instructions can be traced by using the special GT B 1000 MCP operator display terminal message. To start tracing, enter the command:

```
<job-number>GT1
```

To stop tracing, enter the command:

```
<job-number>GT0
```

The <job-number> is the environment B 1000 job number.

The trace output is on the line printer, interspersed with 1400 printer output. An example of trace output is shown in Figure 5-1.

The circled numbers in Figure 5-1 correspond to the following numbered descriptions.

1. The instruction address register in decimal and 1400 machine code.
2. The 1400 instruction to be executed.
3. The A and B registers in 1400 machine code.
4. The sense switch settings.
5. The arithmetic condition indicator (<, =, >).
6. The overflow indicator (OV if set, otherwise blank).
7. The index registers X1, X2, and X3 in 1400 machine code.
8. The contents of 1400 memory locations pointed to by the A and B registers. (Asterisks will indicate that the corresponding register is not a valid 1400 address).

The trace output also contains any 1400 Interpreter commands entered and any messages from the 1400 Interpreter (or 1400 program). The 1400 commands are preceded on the listing with a hyphen and greater than sign (->). Messages from the 1400 Interpreter are preceded by the less than sign and hyphen (<-).

B 1000 PROGRAM SWITCHES

The B 1000 program switch 0 in the environment has special significance to the 1400 Interpreter.

When the 1400 environment goes to B 1000 beginning of job, the 1400 Interpreter searches for a card deck to load. If one is found, an automatic LOAD operation is performed. If a card deck is not found, the 1400 Interpreter displays "READY" on the B 1000 operator display terminal and waits for an accept. Setting switch 0 to a non-zero value causes the 1400 Interpreter to unconditionally attempt to open the card file; if the file is not found, the B 1000 MCP displays an appropriate "file missing" message.

The B 1000 switches may be set in two ways: by the EXECUTE or the MODIFY statements.

Examples:

```
MO A/B SW 0 = 1  
EX A/B SW 0 = 1
```



```

->LOAD ①
00001 001 OP=>008015 A= B= SW=A
00008 008 OP=>022026 A=0C7 B=C14 SW=A
00015 015 OP=>030034 A=021 E=C25 SW=A
00022 022 OP=>041 A=029 E=033 SW=A
00026 026 OP=>045 A=040 E=04C SW=A
00030 030 OP=>053 A=044 E=044 SW=A
00034 034 OP=L072100 A=052 E=C52 SW=A
00041 041 OP=L026 A=052 E=C0C SW=A
00026 026 OP=/I99 A=C26 E=045 SW=A
00030 030 OP=>027 A=I99 E=I99 SW=A
00034 034 OP=A099029 A=026 E=C26 SW=A
00041 041 OP=<027 A=096 E=026 SW=A
00045 045 OP=B001100 A=026 E=026 SW=A
00053 053 OP=B026 A=0C1 E=C99 SW=A
00026 026 OP=/H99 A=026 E=C57 SW=A
00030 030 OP=>027 A=H99 E=C99 SW=A
00034 034 OP=A099029 A=026 E=C26 SW=A
00041 041 OP=<027 A=C96 E=026 SW=A
00045 045 OP=B001100 A=026 E=026 SW=A
00053 053 OP=B026 A=0C1 E=099 SW=A
00026 026 OP=/G99 A=026 E=C57 SW=A
00030 030 OP=>027 A=G99 E=F99 SW=A
00034 034 OP=A099029 A=C26 E=026 SW=A
00041 041 OP=<027 A=096 E=C26 SW=A
00045 045 OP=B001100 A=026 E=026 SW=A
00053 053 OP=B026 A=0C1 E=099 SW=A
00026 026 OP=/F99 A=026 E=C57 SW=A
00030 030 OP=>027 A=F99 E=E99 SW=A
00034 034 OP=A099029 A=026 E=026 SW=A
00041 041 OP=<027 A=C96 E=026 SW=A
00045 045 OP=B001100 A=026 E=026 SW=A
00053 053 OP=B026 A=0C1 E=099 SW=A
00026 026 OP=/E99 A=026 E=057 SW=A
00030 030 OP=>027 A=E99 E=D99 SW=A
00034 034 OP=A099029 A=026 E=026 SW=A
00041 041 OP=<027 A=096 E=026 SW=A
00045 045 OP=B001100 A=026 E=026 SW=A
00053 053 OP=B026 A=0C1 E=099 SW=A
00026 026 OP=/D99 A=026 E=057 SW=A
00030 030 OP=>027 A=D99 E=C99 SW=A
00034 034 OP=A099029 A=026 E=026 SW=A
00041 041 OP=<027 A=C96 E=026 SW=A
00045 045 OP=B001100 A=026 E=026 SW=A
00053 053 OP=B026 A=0C1 E=099 SW=A
00026 026 OP=/C99 A=026 E=057 SW=A
00030 030 OP=>027 A=C99 E=B99 SW=A
00034 034 OP=A099029 A=026 E=026 SW=A
00041 041 OP=<027 A=096 E=C26 SW=A
00045 045 OP=B001100 A=026 E=026 SW=A
00053 053 OP=B026 A=0C1 E=099 SW=A
00026 026 OP=/B99 A=026 E=057 SW=A
00030 030 OP=>027 A=B99 E=A99 SW=A
00034 034 OP=A099029 A=C26 E=026 SW=A
00041 041 OP=<027 A=096 E=C26 SW=A
00045 045 OP=B001100 A=026 E=026 SW=A
00053 053 OP=B026 A=0C1 E=099 SW=A
00026 026 OP=/A99 A=026 E=057 SW=A
00030 030 OP=>027 A=A99 E=I99 SW=A
00034 034 OP=A099029 A=C26 E=026 SW=A
00041 041 OP=<027 A=096 E=026 SW=A
00045 045 OP=B001100 A=026 E=026 SW=A
00053 053 OP=B026 A=0C1 E=099 SW=A
00026 026 OP=/+99 A=026 E=057 SW=A
00030 030 OP=>027 A=+99 E=R99 SW=A

```

```

⑤⑥ ⑦ ⑧
X1= X2= X3= *****
X1= X2= X3= 5>022026,030034,041,045,0 6>C30034,041,045,053L0721
X1= X2= X3= 4>041,045,053L0721001026 1>045,C53L0721001026
X1= X2= X3= 5>053L0721001026 / 3L0721001026 /0591
X1= X2= X3= 01026 /C991,001/00 01026 /C991,001/00
X1= X2= X3= 6 /C991,001/001116 6 /0991,001/001116
X1= X2= X3= /0991,001/001116IC+1 /C991,001/001116IC+1
X1=001 X2=011 X3=I0+ /0991,001/001116I0+1 1/C991,001/001116I0+1
X1=001 X2=011 X3=I0+ /I99,027AC99029<027B00110 B0C110C BC26
X1=001 X2=011 X3=I0+ /I99,027AC99029<027B00110 /I99,027AC99029<027B00110
X1=001 X2=011 X3=I0+ 6I0+1 /H99,027AC99029<027B00110 /H99,027AC99029<027B00110
X1=001 X2=011 X3=I0+ /H99,027A099029<027B00110 /H99,027A099029<027B00110
X1=001 X2=011 X3=I0+ /H99,027AC99029<027B00110 +1 /H99,027AC99029<027B00110
X1=001 X2=011 X3=I0+ /H99,027AC99029<027B00110 I2/
X1=001 X2=011 X3=I0+ /H99,027AC99029<027B00110 /H99,027AC99029<027B00110
X1=001 X2=011 X3=I0+ 6I0+1 /G59,027AC99029<027B00110 /G59,027AC99029<027B00110
X1=001 X2=011 X3=I0+ /E99,027A099029<027B00110 /E99,027A099029<027B00110
X1=001 X2=011 X3=I0+ L096116,105106,1101108101 +1 /G59,027AC99029<027B00110
X1=001 X2=011 X3=I0+ /E99,027A099029<027B00110 I2/
X1=001 X2=011 X3=I0+ /G99,027A099029<027B00110 /G99,027A099029<027B00110
X1=001 X2=011 X3=I0+ 6I0+1 /F99,027AC99029<027B00110 /F99,027AC99029<027B00110
X1=001 X2=011 X3=I0+ /F99,027A099029<027B00110 /F99,027A099029<027B00110
X1=001 X2=011 X3=I0+ L096116,105106,1101108101 +1 /F99,027AC99029<027B00110
X1=001 X2=011 X3=I0+ /F99,027A099029<027B00110 I2/
X1=001 X2=011 X3=I0+ /E99,027A099029<027B00110 /E99,027A099029<027B00110
X1=001 X2=011 X3=I0+ 6I0+1 /E99,027A099029<027B00110 /E99,027A099029<027B00110
X1=001 X2=011 X3=I0+ /E99,027A099029<027B00110 /E99,027A099029<027B00110
X1=001 X2=011 X3=I0+ L096116,105106,1101108101 +1 /E99,027AC99029<027B00110
X1=001 X2=011 X3=I0+ /E99,027A099029<027B00110 I2/
X1=001 X2=011 X3=I0+ /D99,027A099029<027B00110 /D99,027A099029<027B00110
X1=001 X2=011 X3=I0+ 6I0+1 /C99,027AC99029<027B00110 /C99,027AC99029<027B00110
X1=001 X2=011 X3=I0+ /C99,027A099029<027B00110 /C99,027A099029<027B00110
X1=001 X2=011 X3=I0+ L096116,105106,1101108101 +1 /C99,027AC99029<027B00110
X1=001 X2=011 X3=I0+ /C99,027A099029<027B00110 I2/
X1=001 X2=011 X3=I0+ /B99,027A099029<027B00110 /B99,027A099029<027B00110
X1=001 X2=011 X3=I0+ 6I0+1 /A99,027AC99029<027B00110 /A99,027AC99029<027B00110
X1=001 X2=011 X3=I0+ /A99,027A099029<027B00110 /A99,027A099029<027B00110
X1=001 X2=011 X3=I0+ L096116,105106,1101108101 +1 /A99,027AC99029<027B00110
X1=001 X2=011 X3=I0+ /A99,027A099029<027B00110 I2/
X1=001 X2=011 X3=I0+ /B99,027A099029<027B00110 /B99,027A099029<027B00110
X1=001 X2=011 X3=I0+ 6I0+1 /A99,027AC99029<027B00110 /A99,027AC99029<027B00110
X1=001 X2=011 X3=I0+ /A99,027A099029<027B00110 /A99,027A099029<027B00110
X1=001 X2=011 X3=I0+ L096116,105106,1101108101 +1 /A99,027AC99029<027B00110
X1=001 X2=011 X3=I0+ /A99,027A099029<027B00110 I2/
X1=001 X2=011 X3=I0+ /+99,027A099029<027B00110 /+99,027A099029<027B00110
X1=001 X2=011 X3=I0+ 6I0+1 /+99,027AC99029<027B00110 /+99,027AC99029<027B00110
X1=001 X2=011 X3=I0+ /+99,027A099029<027B00110 /+99,027A099029<027B00110
X1=001 X2=011 X3=I0+ L096116,105106,1101108101 +1 /+99,027AC99029<027B00110
X1=001 X2=011 X3=I0+ /+99,027A099029<027B00110 I2/

```

Figure 5-1. Trace Output

SECTION 6

1400/CREATE1311

GENERAL

The function of the 1400/CREATE1311 program is to create a B 1000 1400 IBM 1311 disk file. It may also be used to initialize the 1311 disk in the 1311 disk format.

It is necessary to create the BCD FILE.TYPE type of files before using them. EBCDIC FILE.TYPE types of files do not have to be created first before use, but may be created if desired. BCD and EBCDIC files must also be initialized in the 1311 disk format before normal 1400 programs can access the disk, with either the IBM CLEARDISK program, or with the special option available with the 1400/CREATE1311 program.

If the disk files are to be accessed by both the B 1700 free-standing 1400 emulator and the 1400 Interpreter, the 1400/CREATE1311 program should not be used. The CREATE 1311 disk program released with the free-standing software should be used, as the 1400 Interpreter can access these disk files, whereas the emulator cannot access the files created by the 1400/CREATE1311 program.

OPERATING PROCEDURES

The 1400/CREATE1311 program is executed with the standard B 1000 EXECUTE statements. The program displays the message "INPUT FILE NAME" on the B 1000 operator display terminal. The operator can then enter the B 1000 file name of the 1311 disk file to be created. After creating the file, the program asks for a new file name. The operator can then enter another B 1000 file name, or a blank to terminate the program.

The program options are controlled by the B 1000 program switches. The method used to invoke a switch follows:

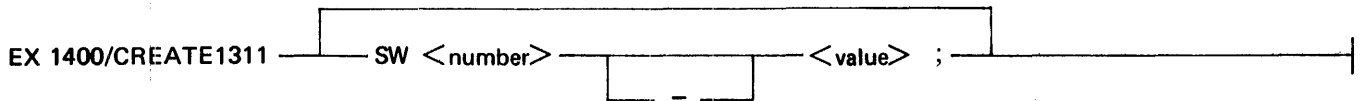

G12391

Example:

EX 1400/CREATE1311 SW 0 = 1; SW 2 = 5;

Switch 0 controls the method of input and the function of the 1400/CREATE1311 program.

| Switch 0 Value | Function |
|----------------|--|
| 0 | B 1000 file names of 1400 IBM 1311 files to be created are entered with B 1000 accept messages. This is the default operating mode. |
| 1 | B 1000 file names are in a card file labeled CARDS, one name to a card, in free-form format. |
| 2 | Only one 1400 IBM 1311 file is created, with no operator intervention. The file created is labeled 1400/1311. |
| 3 | This option allows BCD files to be converted and copied into the EBCDIC format, or the opposite. The B 1000 file name to be copied/translated and the new file name are entered with B 1000 accept messages. |

File names consist of pack name, family name and/or file name, each name having one to ten alphanumeric characters, the names separated by slashes. Refer to Names in Section 1 for the discussion of B 1000 file names.

Switch 1 controls which type of file is created, either EBCDIC or BCD. Unlike BCD files, EBCDIC files do not have to be created. If SW 1 equals 0, the files created are in the BCD format. If SW 1 is nonzero, the files are created in the EBCDIC format. This switch has no effect on the copy function (SW 0 equal to 3).

Switch 2 can be used when it is desired to save B 1000 disk space and the 1400 programs access only the first section of the 1311 disk. If SW 2 equals 0 the whole 1311 disk is allocated. If SW 2 is from 1 to 9, the percentage of the file created is equal to the value multiplied by 10. For example, if SW 2 is equal to 1 only the first one-tenth of the file is to be created. Switch 2 has no effect on the copy function (SW 0 equal to 3).

1400 IBM 1311 DISK INITIALIZATION

For most applications, the IBM CLEARDISK routine is used to initialize the 1311 disk. However, if only the 1311 disk natural addresses are desired for initialization, the initialization option may be used. To invoke this option, switch 0 must equal 1 for card input. One or more INIT cards must follow the file name card. The INIT card is in fixed-format, as follows:

| Card Columns | Contents |
|--------------|---|
| 1-4 | The literal INIT. |
| 5-8 | Either MOVE or LOAD, specifying move or load mode sectors. |
| 9-14 | A numerical starting 1311 disk address. |
| 15-20 | A numerical ending 1311 disk address. |
| 16 | A single character. This character is used as the initialization pattern on the 1311 disk. This character may be a blank. |

B 1000 Systems 1400 Interpreter Reference Manual
1400/CREATE1311

Multiple INIT cards may be used so that different 1400 sector modes may be created. If the 1400 natural drive addresses are desired for different drives, the natural beginning and ending addresses should be used (for example, drive 2 addresses ranges from 020000 to 039999).

An example of an execute deck follows:

```
?EX 1400/CREATE1311 SW 0 = 1;  
?DATA CARDS  
1400/1311.0  
INITMOVE0000000019999  
1400/1311.2  
INITMOVE000000000199          (Natural disk addresses)  
INITLOAD000200000300          (Disk pattern equals blanks)  
INITMOVE000300019999M        (Disk pattern equals "M")  
1400/1311.4  
INITMOVE040000059999          (Natural drive addresses)  
?END
```

The addresses do not have to be at special 1311 boundaries, but they must not overlap and must be in sequential order; however, missing 1311 sectors are permissible.

Because of the fixed-form format INIT card, file names beginning with "INIT" should not begin in column 1 of the file name card.

INDEX

- ? Command, 4-2
- ACCEPT Command, 4-1
- ALTER Command, 4-3
- Alter 1400 Memory, 4-3
- Arithmetic Instructions, 2-1
- AX Command, 4-1
- B 1000 Program Switches, 5-4
- Begin Single Stop Mode, 4-18
- Bridges, 1-4
- Card Punch Declaration, 3-4
- Card Reader Declaration, 3-2
- CARD.READER, 3-2
- CLEAR Command, 4-4
- Clear 1400 Console Printer, 4-4
- Close B 1000 File, 4-8
- Comment Command, 4-24
- Compilation, 3-9
- Compile Statement, 3-10
- CONSOLE, 3-8
- Console Declaration, 3-8
- Continue 1400 Processing, 4-12
- Disk Assignment, 5-3
- Disk Declaration, 3-6
- Disk Initialization, 3-7, 6-2
- Disk Instructions, 2-3
- DISPLAY Command, 4-5
- Display 1400 Memory, 4-5
- DUMP Command, 4-6
- Dump 1400 Memory, 4-6
- Dynamic Statement, 5-1
- END Command, 4-7
- End 1400 Program, 4-7
- Environment-name, 1-5
- EOF Command, 4-8
- EOJ Command, 4-9
- EQUALS Command, 4-10
- Execute Statement, 3-11, 5-1
- Family-name, 1-5
- File Statement, 5-2
- File-name, 1-5
- Hardware Declaration, 3-5
- Input Instructions, 2-1
- Inquiry Status, 4-23
- Instruction Tracing, 5-4
- Instructions Interpreted, 2-1
- Interpreter Commands, 4-1
- Interpreter Features, 1-1
- Interpreter Operations, 4-1
- INTOPT, 4-26
- INVERTED.EDIT, 3-8, 4-26
- Line Printer Comment, 4-25
- Line Printer Declaration, 3-3
- LOA Command, 4-11
- Load Instructions, 2-2
- Load 1400 Program, 4-11
- Logical Instructions, 2-2
- Loops, 1-4
- Magnetic Tape Instructions, 2-2
- Main Syntax, 3-1
- MCP Interface, 5-1
- MEMORY.SIZE, 3-2
- Miscellaneous Instructions, 2-3
- Modify Statement, 5-1
- Move Instructions, 2-2
- Names, 1-5
- OFF Command, 4-13
- OK Command, 4-12
- ON Command, 4-13
- Operator Display Terminal Comment, 4-24
- Optional Declarations, 3-8
- Optional Items, 1-3
- Output Instructions, 2-1
- Pack-name, 1-5
- PRINTER, 3-3
- PUNCH, 3-4
- Railroad Diagrams, 1-2
- RCB.ALLOWED, 4-26
- Read Column Binary, 4-26
- REGULAR Command, 4-14
- Related Documents, 1-2
- Required Items, 1-3
- RESET Command, 4-15

INDEX (Cont)

- Reset Disk Keys, 4-13
- Reset 1400 Processor, 4-15
- Restart 1400 Processing, 4-16
- Resume Regular Mode, 4-14
- RUN Command, 4-16

- Send Console Data Command, 4-2
- SET Command, 4-17
- Set Disk Keys, 4-13
- Set 1400 Memory to a Character, 4-17
- Set 1400 Sense Switches, 4-21
- SINGLE Command, 4-18
- Stacker Selection, 3-4
- STACKER.1, 3-4
- STACKER.2, 3-4
- START Command, 4-19
- Start 1400 Processing, 4-19
- STOP Command, 4-20
- Stop 1400 Processing, 4-20
- Supervisory Console Instructions, 2-3
- SWITCHES Command, 4-21

- Syntax Conventions, 1-2
- Syntax of the 1400/IEP, 3-1
- SYSIN, 4-26
- SYSIN Declaration, 3-2

- TAPE, 3-7
- Tape Assignment, 5-3
- Tape Declaration, 3-7
- TAPE.BUFFER.SIZE, 3-8
- TAPE.RETRIES Declaration, 3-8
- Terminate, 4-9
- Tracing, 5-4
- TRANSFER Command, 4-22
- Transfer to 1400 Memory Location, 4-22

- WY Command, 4-23

- 1311, 3-6
- 1400 Address Conversion, 4-10
- 1400 IEP, 3-1
- 1400/CREATE1311, 6-1

Documentation Evaluation Form

Title: B 1000 Systems 1400 Interpreter Reference Manual

Form No: 1127560
Date: December 1981

Burroughs Corporation is interested in receiving your comments and suggestions regarding this manual. Comments will be utilized in ensuing revisions to improve this manual.

Please check type of Suggestion:

- Addition Deletion Revision Error

Comments:

From:

Name _____
Title _____
Company _____
Address _____

Phone Number _____ Date _____

Remove form and mail to:
Burroughs Corporation
Documentation Dept., TIO - West
1300 John Reed Court
City of Industry, CA 91745
U.S.A.