

REF 22 197

**MD 122  
MINI DISK DRIVE**

**PRODUCT SPECIFICATION  
1885 3218  
REVISION A**

**BURROUGHS  
OEM CORPORATION  
DETROIT, MICHIGAN 48232**

*dt*



## TABLE OF CONTENTS

Paragraph		Page
1.0	SCOPE .....	1
2.0	RELATED DOCUMENTS .....	1
3.0	PRODUCT DESCRIPTION .....	1
3.1	General .....	1
3.2	Functional Components .....	5
3.2.1	Mechanical Assemblies .....	5
3.2.1.1	Disk Positioning Mechanism .....	5
3.2.1.2	Spindle and Motor Drive .....	5
3.2.1.3	Positioner (Actuator) .....	5
3.2.1.4	Heads .....	6
3.2.1.5	Disks .....	6
3.2.2	Electronic Assemblies .....	6
3.2.2.1	Data Channel Electronics .....	6
3.2.2.2	Positioner Electronics .....	6
3.2.2.3	Device Controller .....	7
4.0	OPERATIONAL FEATURES .....	7
4.1	Storage and Retrieval Features .....	7
4.1.1	Logical Addressing .....	7
4.1.2	Implicit Seek .....	8
4.1.3	Search .....	8
4.2	Data Integrity Features .....	8
4.2.1	Interface Integrity .....	8
4.2.2	Disk Integrity .....	9
4.3	System Integrity Features .....	9
4.3.1	Positioner Calibration .....	9
4.3.1.1	Disk Initialization .....	10
4.3.1.2	Initial Calibration .....	10
4.3.1.3	Recalibration .....	10
4.3.2	Retry on Read Error .....	10
4.3.3	Sector Relocation .....	13
4.3.4	Write Protection .....	13
4.3.5	Disk Removal Protection .....	13
4.3.6	Media End-of-Life Warning .....	14
4.4	Media Life Extension Features .....	14
4.4.1	Wear Distribution .....	14
4.4.2	Wear Prevention .....	14
4.5	Maintenance Features .....	14
4.5.1	On-Board Confidence Test .....	14
4.5.2	Interface Wrap-Around Test .....	15
4.5.3	Stand-Alone Diagnostic Tests .....	15

## Table of Contents (Cont.)

5.0	FUNCTIONAL CHARACTERISTICS .....	15
5.1	Recording Characteristics .....	15
5.2	Storage Capacity .....	15
5.3	Performance Characteristics .....	16
5.3.1	Positioner Performance .....	16
5.3.2	Rotational Characteristics .....	16
5.3.3	Time to Access a Data Sector .....	16
6.0	PHYSICAL CHARACTERISTICS .....	17
7.0	CONTROLS AND INDICATORS .....	17
7.1	Controls .....	17
7.2	Indicators .....	17
8.0	INTERFACE .....	17
8.1	General .....	17
8.2	Logic and Semantic Interface .....	18
8.2.1	Logic Interface .....	18
8.2.2	Semantic Interface .....	18
8.2.2.3	System Integrity Functions .....	21
8.3	Electrical and Mechanical Interface .....	21
8.4	Data Format .....	21
9.0	RELIABILITY AND SERVICE GOALS .....	21
9.1	Reliability .....	21
9.1.1	Mean Time Between Failure (MTBF) .....	21
9.1.2	Media Life .....	21
9.1.3	Error Rate .....	21
9.2	Service Goals .....	22
9.2.1	Preventive Maintenance .....	22
9.2.2	Mean Time to Repair (MTTR) .....	22
9.2.3	Service Life .....	22
10.0	INSTALLATION .....	22
10.1	Power Requirements .....	22
10.2	Grounding Requirements .....	22
10.3	Environmental Requirements .....	23
10.3.1	Operating Conditions .....	23
10.3.1.1	Temperature and Humidity .....	23
10.3.1.2	Shock and Vibration .....	23
10.3.1.3	Radio Frequency Radiation .....	23
10.3.1.4	Atmospheric Pollutants .....	23
10.3.1.5	Altitude and Barometric Pressure .....	23
10.3.2	Non-Operating Conditions .....	23
10.3.2.1	Long-Term Temperature and Humidity .....	23
10.3.2.2	Shock and Vibration .....	24
10.4	Air Flow .....	24
10.5	Drive Orientation .....	24
10.6	Connectors .....	24
11.0	SAFETY STANDARDS .....	24
12.0	GLOSSARY OF TERMS .....	24-25-26

Table of Contents (Cont.)

LIST OF ILLUSTRATIONS

Figure

1	Mini Disk Drive Overall Layout and Dimensions .....	2
2	Connector and Board Locations .....	3
3	Drive - Left Side View .....	4
4	Address Retries .....	11
5	Data Retries .....	12

LIST OF TABLES

Table

1	Command Summary .....	19
2	Status Summary .....	20

The information contained in this specification does not necessarily imply a license under patents or pending applications of Burroughs Corporation or assure a freedom from patent rights of others. No warranties of any kind are expressed or implied by reason of this publication. The specification is subject to change without notice.



# MD 122 MINI DISK DRIVE PRODUCT SPECIFICATION

## 1.0 SCOPE

This document describes the physical and functional characteristics and the specification of the Burroughs MD 122 Mini Disk Drive.

## 2.0 RELATED DOCUMENTS

The following documents are related to this specification. In the event of a conflict between this specification and the related documents, this specification shall have precedence.

<u>Related Document</u>	<u>Specification</u>
Implementation Interface Specification	1883 8722
Logic and Semantic Interface Specification	1883 7773

## 3.0 PRODUCT DESCRIPTION

### 3.1 General

The MD 122 Mini Disk Drive is a random access storage device that uses two removable 8-inch flexible Mylar<sup>®</sup> disks as storage media to provide 6.3 million bytes of on-line storage and unlimited off-line storage.

The drive contains an Advanced Microprocessor Controller (AMC) which performs many of the functions traditionally required of a Host system controller. The AMC accepts Host controller commands and translates them into basic control signals for the drive to execute. The presence of the AMC allows the Host system to address data by logical sector rather than head, track and physical sector. Some of the functions performed by the AMC are:

- Logical to physical address translation.
- File search using Host supplied parameters.
- Sector relocation.
- Error detection, retry and correction.
- Media wear monitoring and warning.
- Error logging and analysis.
- Confidence/Diagnostic tests.

The drive is intended for use as a data storage or a program and data load/dump device for data processing, or data entry/collection systems.

-----  
® - Mylar is a registered trade name of DuPont.

DRIVE SHOWN IN  
OPERATING ORIENTATION

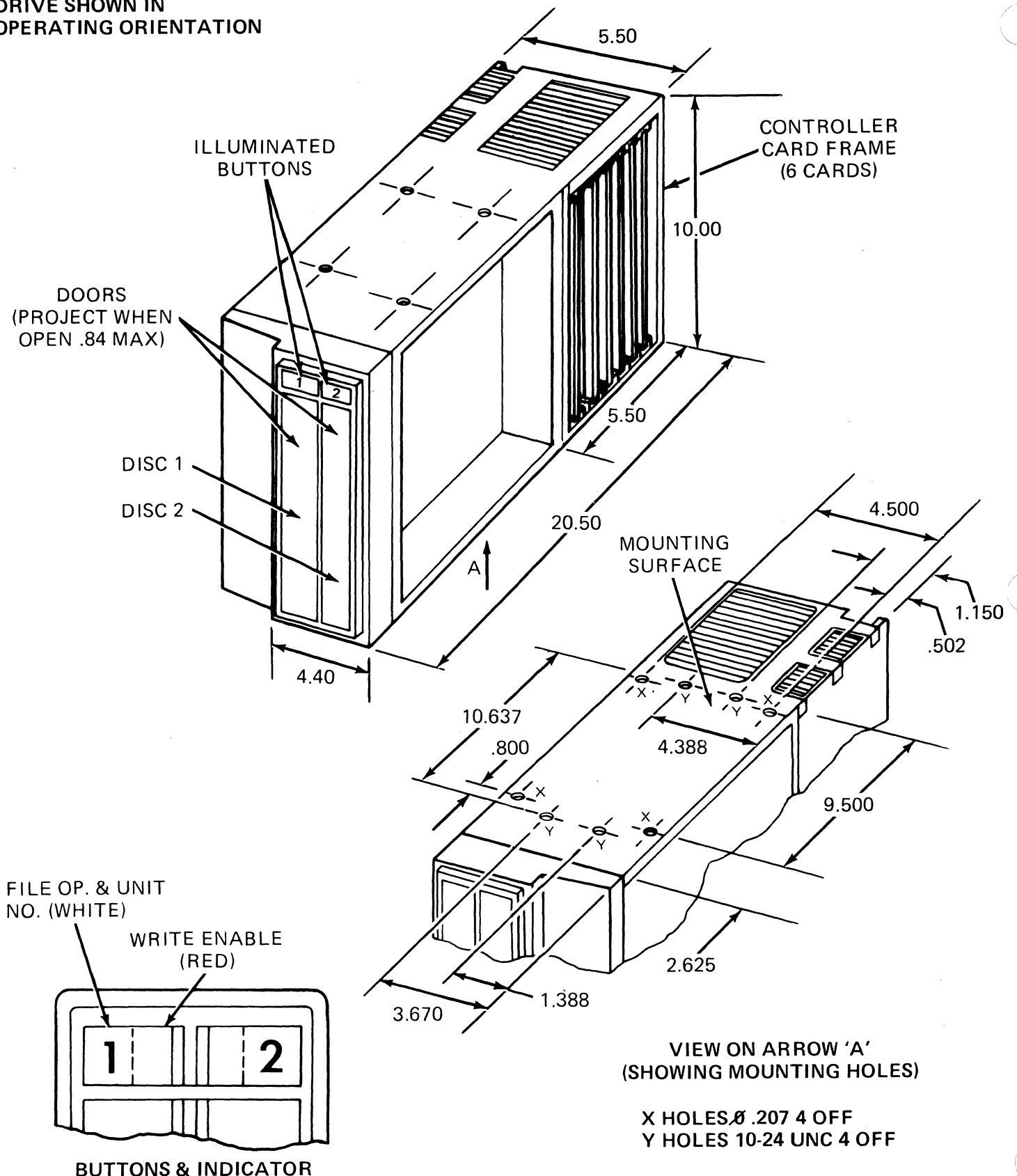

VIEW ON ARROW 'A'  
(SHOWING MOUNTING HOLES)

X HOLES  $\varnothing$  .207 4 OFF  
Y HOLES 10-24 UNC 4 OFF

FIGURE 1  
OVERALL DIMENSIONS



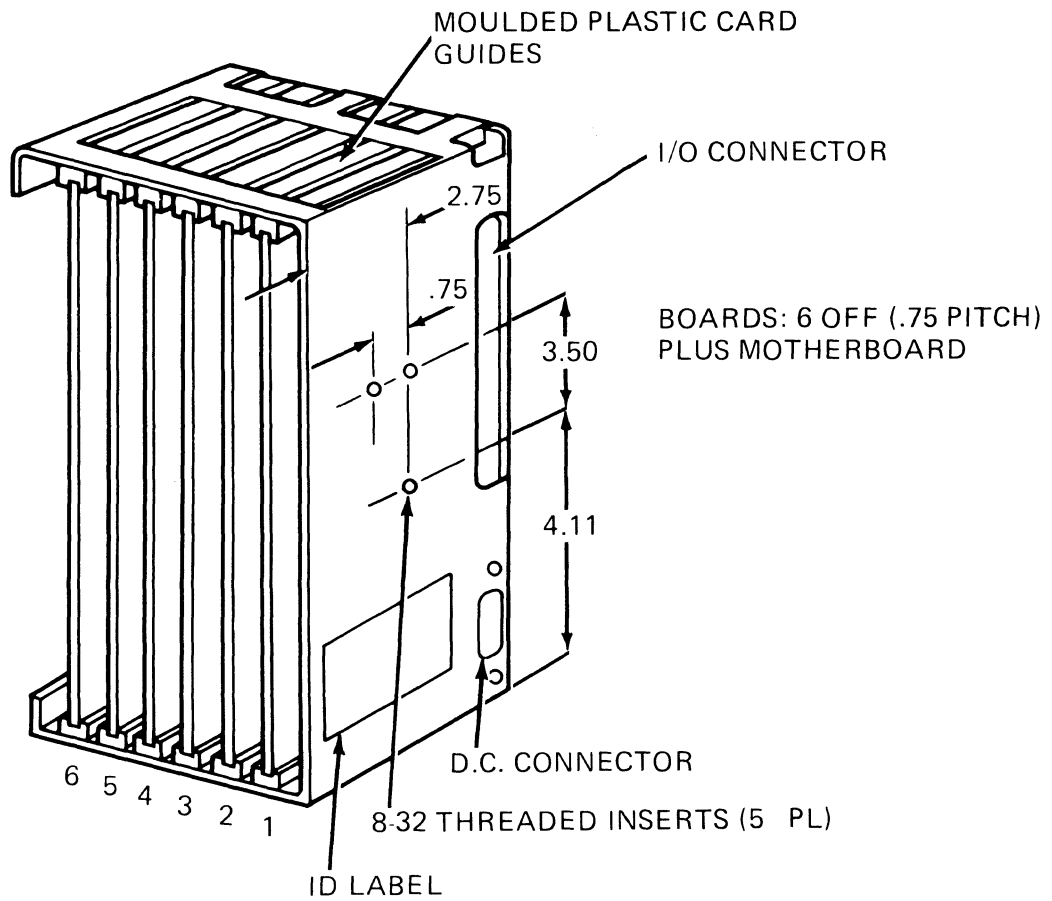

BOARD NO.	DESCRIPTION
1	INTERFACE 1
2	INTERFACE 2
3	MICROPROCESSOR CONTROLLER
4	SEARCH
5	DMA
6	SEQUENCE CONTROLLER

FIGURE 2

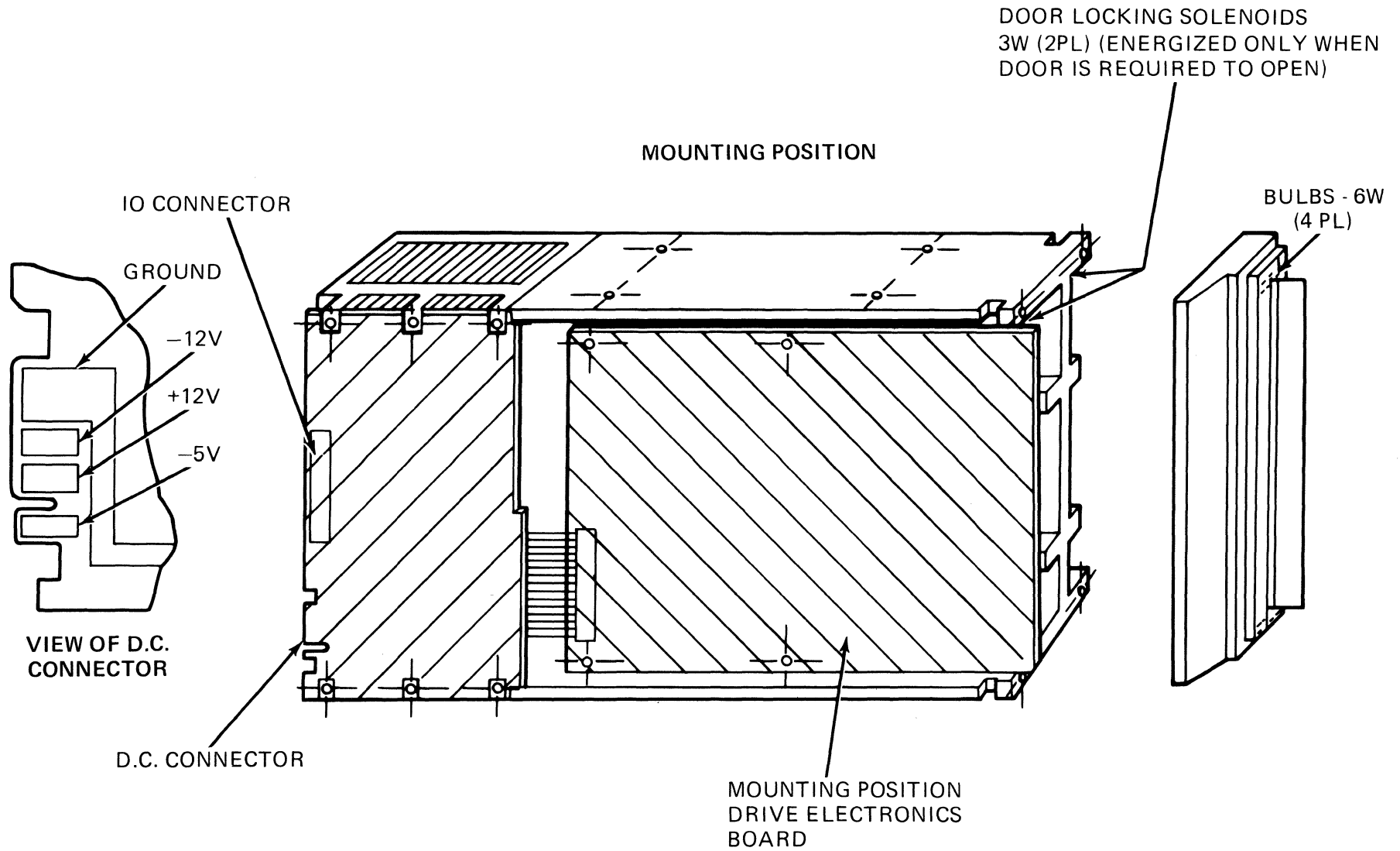

FIGURE 3

## 3.2 Functional Components

The MD 122 Mini Disk Drive consists of functional subassemblies which are mounted on an aluminum casting. The casting provides the structural strength required for accurate head positioning.

The drive may be divided into two major categories, mechanical and electronic.

### 3.2.1 Mechanical Assemblies

#### 3.2.1.1 Disk Positioning Mechanism

Disks are inserted into the drive through the two facia doors (see Figure 1). The disk jackets have an arrangement to latch the disk in place when it is inserted into the drive.

In addition to the jacket, each disk also has a protective outer sleeve. When a disk is inserted into the drive, a mechanism in the drive ensures that the disk is fully in the home position and latched before the sleeve can be withdrawn. The protective sleeve must be in place before a disk may be withdrawn from the drive. This ensures that the magnetic media is always covered except when in the drive.

Disk location is achieved with a cone assembly passing through the disk mounting hole and sliding into a female recess in the spindle. The cone also carries the disk clamping ring that clamps the disk to the spindle. The cone assembly is mechanically activated by door movement.

#### 3.2.1.2 Spindle and Motor Drive

The spindle is common to both disks and is located between them. It has a female recess at each end for the cone assembly for each disk. The spindle assembly is mounted to the main casting and is driven by a D.C. motor via a speed reducing pulley and belt. Motor speed is maintained within limits by a servo system using optical feedback from the spindle.

When either door is opened, both disks go off line, and the carriage retracts to the home position. This action will interrupt any operation in progress and will cause the device to report to the Host system that the drive(s) is not ready.

Either door may be individually locked under program control. The drive will operate properly with only one disk inserted, provided both doors are closed.

#### 3.2.1.3 Positioner (Actuator)

The Positioner is a linear voice-coil type for high performance and accuracy. It consists of a moving coil mounted on a carriage assembly which moves along linear bearings within a permanent magnet assembly. Four heads, one for each surface, are mounted on the arms of the carriage assembly.

A closed-loop servo system positions the read/write heads using feedback from an optical grating mounted on the carriage assembly (refer to paragraph 3.2.2.2). The Positioner is capable of continuous operation.

#### 3.2.1.4 Heads

Two pairs of heads, one pair for each disk, are mounted via a compliant suspension to the Positioner carriage assembly. When loaded, two heads are in contact with each disk and are arranged so that the core of one head uses one leg of the opposing catamaran as a pressure pad and vice versa.

#### 3.2.1.5 Disks

The disk used for this drive is a pre-initialized 8-inch Mylar disk.

### 3.2.2 Electronic Assemblies

- a. Data channel preamplifier
- b. Data encode and decode circuitry
- c. Positioner electronics
- d. Device controller
- e. Motor speed control

The data channel preamplifier is mounted on a small P.C.B. below the voice coil magnet. The motor speed control and solenoid drivers are mounted on a P.C.B. above the preamplifier. The positioner circuits and data encode/decode circuits are mounted on a large P.C.B. on the opposite side of the drive from the small P.C.B.

The Device Controller is contained in six smaller printed circuit boards mounted perpendicular to the plane of the disk in a card cage at the back of the drive (see Figure 1).

The preamplifier provides the required amplification of the head signals.

#### 3.2.2.1 Data Channel Electronics

The Data Channel electronics consist of circuits to provide head selection, MFM encode/decode, read/write, data separation, and clocking. In addition, a circuit is present to read the servo tri-bits to provide Positioner calibration information to the Device Controller.

#### 3.2.2.2 Positioner Electronics

The Positioner electronics consist primarily of a closed-loop servo system operating in both velocity and position modes under the supervision of the Advanced Microprocessor controller.

### 3.2.2.3 Device Controller

The Device Controller accepts and executes commands from the Host system and provides data and status to the Host system.

The Device Controller consists of three functional blocks:

- a. Advanced Microprocessor Controller (AMC)
- b. Host Interface Circuitry
- c. Data Channel Control and Buffers

The Device Controller is capable of executing the full set of functions (commands and status reports) described in paragraph 8.2 - Logic and Semantic Interface.

Overall control of the drive is via the Advanced Microprocessor Controller with its associated program store, scratchpad memory, and input/out latches. The AMC contains routines to control the basic functions of the Positioner and the Data Channel and to execute the retry procedure, the relocation of faulty sectors, the correction of data errors using the error syndrome, and the maintenance test routines.

The Host Interface Circuitry contains line drivers and receivers as well as the parity generation and check circuits.

The Data Channel Control, in addition to its basic function, also contains two 256-byte buffers to accommodate asynchronous transfer of data to and from the Host system.

## 4.0 OPERATIONAL FEATURES

### 4.1 Storage and Retrieval Features

The following features pertain to the basic storage and retrieval functions of the MD 122 Mini Disk Drive. For a full description of the commands executable by the drive, refer to the Logic and Semantic Interface specification identified in paragraph 2.0.

#### 4.1.1 Logical Addressing

The following definitions apply in the context of MD 122 addressing.

Drive - One of two removable disks.

Sector - One of forty-five (45) physical subdivisions of a track, capable of storing 256 bytes of data.

Block - One of 24,462 logical subdivisions of a "disk", capable of storing 256 bytes of data.

The Host system, through the Host controller, addresses data by drive and block number. The AMC translates the block number to a surface, track and physical sector address. This translation takes into account any relocation of defective sector.

#### 4.1.2 Implicit Seek

The Host system accesses the disk by issuing a READ or WRITE command to the AMC together with three parameters: drive number, block number and number of bytes to be transferred. After translating the block number to physical head, track and sector address and checking the sector relocation table (RAM) for possible relocation, the AMC positions the actuator over the selected track and begins reading sector addresses.

When the read/write head is one sector before the requested block, the drive informs the Host controller through the N-SECTORS-BEFORE-READ or N-SECTORS-BEFORE-WRITE status indication.

#### 4.1.3 Search

The drive has the capability to search a file for data content that satisfies a condition relative to a tag argument. This capability is implemented via the SEARCH command (refer to paragraph 8.2).

In the SEARCH command, the Host system supplies parameters defining the type and scope of the search and the tag argument to be used. Conditional tests available are:

- equal to
- not equal to
- less than
- less than or equal to
- greater than
- greater than or equal to

Upon acceptance of the SEARCH command, the drive will independently search the defined area of the disk for a tag that satisfies the specified condition relative to the tag argument.

Upon completion of the search, the drive will communicate to the Host, via the READ-SEARCH-RESULT command, the block number and offset within the block of the first tag that satisfied the condition, together with the contents of the block.

#### 4.2 Data Integrity Features

The drive incorporates the following features to ensure the integrity of data transfers within the disk subsystem.

#### 4.2.1 Interface Integrity

The operation of the interface between the Host controller and the device controller consists of the transfer of sequences of codes from one controller to the other. The interface definition permits variable length sequence transfers in any of the four modes: COMMAND, STATUS, HOST-RECEIVE and HOST-SEND.

The integrity of the interface is monitored by two parity checks: longitudinal and vertical. The longitudinal parity check (LPC) is even and is applied to every sequence of codes transferred across the interface. The vertical parity check is odd and is applied to each 8-bit code transferred on interface data buses. For a complete description of the interface protocol and error checking, refer to the Logic and Semantic Interface specification.

#### 4.2.2 Disk Integrity

Error detection and correction in the MD 122 is an independent function of the device controller and is transparent to the Host system except for a minor delay in transfer when retry or correction is required.

There are separate Error Correction Codes (ECC) for the address field and data field within each sector. The device controller computes the data ECC during the writing of each field and records it at the end of the field. When the sector is subsequently read, the device controller recomputes the ECC during the read and compares the result with the recorded ECC. If the computed and recorded ECC's match, the data in the sector buffer is sent to the Host system. If a match is not obtained, the AMC corrects the data in the buffer using the recorded ECC. If error correction is not possible, the retry procedure is invoked (refer to paragraph 4.3.2).

The characteristics of the error correction algorithm are as follows:

Address Field Length:	4 bytes
Address ECC:	16-bit Fire code
Data Field Length:	256 bytes
Data ECC:	32-bit Fire code
Detection:	Single error bursts of 32 bits or less
Correction:	Single error bursts of 11 bits or less

The above scheme will accommodate pin hole defects up to 0.001 inch X 0.004 inch approximate size and errors due to transient noise bursts up to 11 microseconds duration.

### 4.3 System Integrity Features

In order to maximize the integrity of the system as a whole and to minimize the requirements placed on the Host system, the following features are incorporated in the MD 122 Mini Disk Drive.

#### 4.3.1 Positioner Calibration

The accuracy of head positioning is affected by dimensional changes in the disk and drive due to temperature and humidity, precision of disk location, mechanical drift and physical tolerance differences between drives. To compensate for these changes and to ensure interchangeability of media, the MD 122 Mini Disk Drive incorporates an automatic Positioner Calibration routine that uses servo tracks written on each disk.

##### 4.3.1.1 Disk Initialization

Disks are initialized at the factory in a controlled environment. During initialization, special servo tracks are written with extreme positional accuracy at the innermost and outermost track positions of each surface. Using servo tracks as positional references, sector headers and data are written, checked and relocated as necessary to produce a fully initialized and certified disk.

##### 4.3.1.2 Initial Calibration

When the drive is powered on and whenever a new disk is inserted, the AMC positions the head over each servo track in turn and measures the track offset from nominal. An extrapolation from these offsets is used by the AMC as a vernier Positioner adjustment on subsequent data track seeks. An initial calibration takes 10 seconds for one disk and less than 20 seconds for two disks.

##### 4.3.1.3 Recalibration

After initial calibration, the drive periodically recalibrates itself to match the thermal and humidity time constants. Recalibration frequency is initially once every 30 seconds, decreasing to once every 16 minutes after the first 57 minutes. Recalibration time is less than three seconds for one disk and less than five seconds for two disks.

Automatic Recalibration -	.5 min	1.5 min	3.5 min	13.5 min	33.5 min
			5.5	17.5	41.5
			7.5	21.5	49.5
			9.5	25.5	57.5

#### 4.3.2 Retry on Read Error

Upon encountering a read error, the AMC initiates one of two retry procedures, depending upon whether the error was in an address field or data field. The following definitions apply to both procedures.



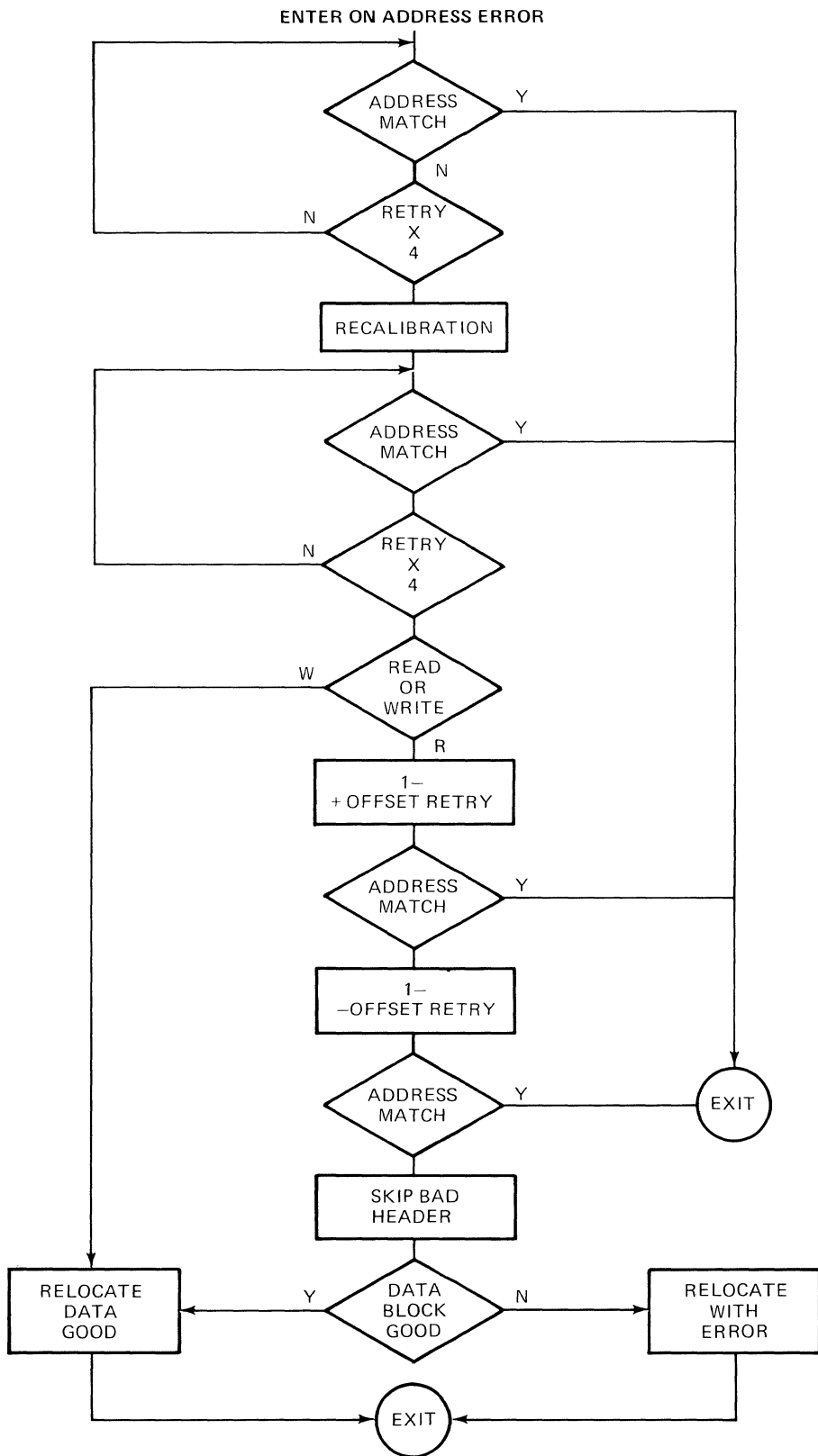

ADDRESS RETRIES

FIGURE 4

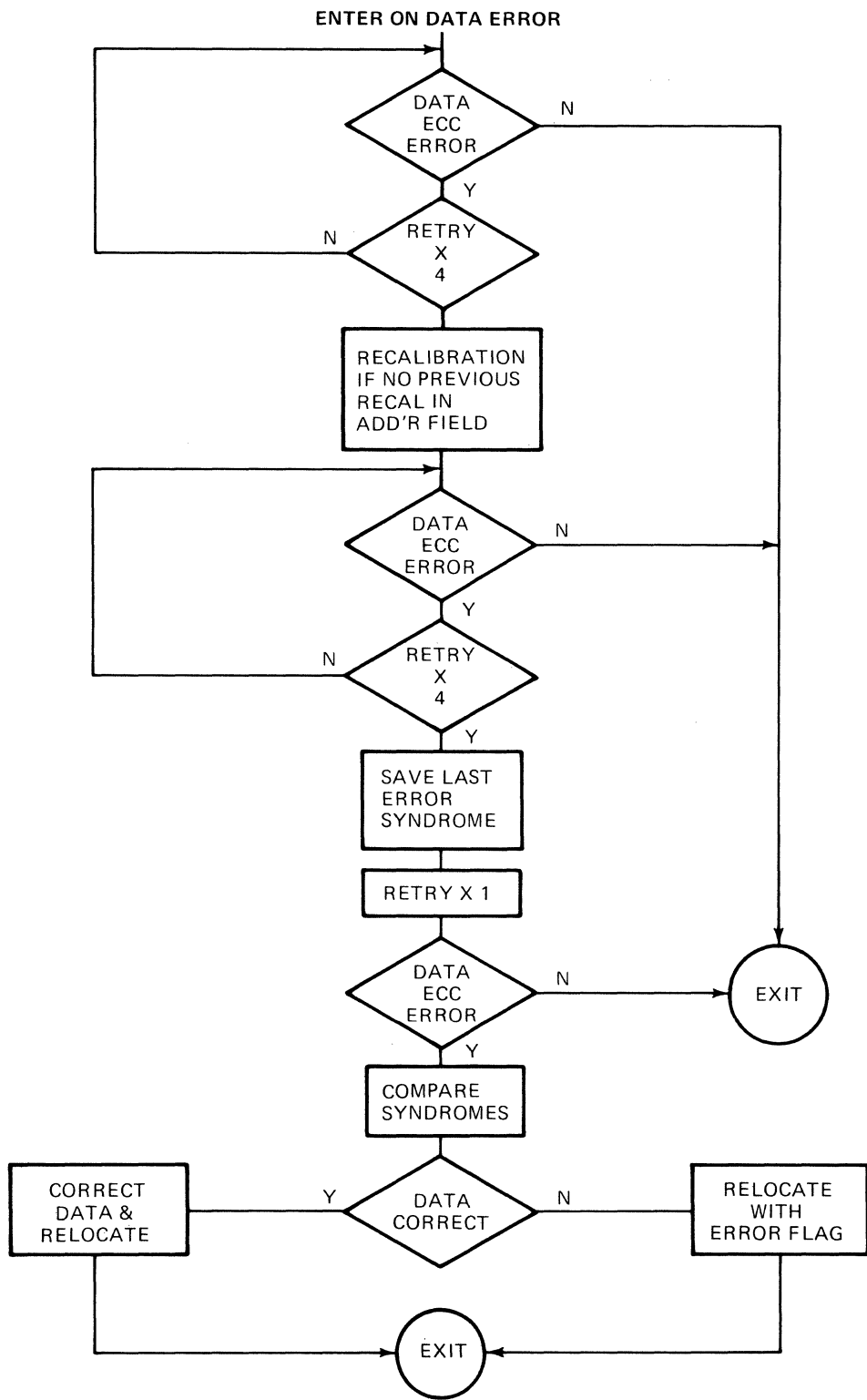

**DATA RETRIES**  
**FIGURE 5**

Normal Retry - a re-read of the sector in question without any Positioner adjustment.

Offset Retry - a re-read of the sector in question after a plus or minus vernier adjustment of the Positioner. See Figures 4 and 5 for Retry Procedures.

If a successful read is achieved at any step, normal operation is resumed after noting the error for statistical purposes. If the entire procedure fails to produce a successful retry, an irrecoverable error exists, the Host System is so notified, and sector relocation is invoked (Refer to paragraph 4.3.3).

Successful retries are transparent to the Host System except for the delay in data transfer.

Recalibration is essentially transparent to the Host system. It is manifested as a hesitation in the interface hand-shaking routine.

#### 4.3.3 Sector Relocation

In addition to the 139 data tracks there are, on each side of the disk, two tracks reserved for maintenance and one track reserved for sector relocation.

If, during operation, a defective sector is detected, the AMC will move it to the relocation track noting the block address in the relocation table. The relocation table is located in random access memory (RAM) and is capable of handling 43 bad sectors per disk.

The updated relocation table is written in a reserved location on one of the maintenance tracks of that disk.

When a disk is inserted into the drive, the AMC reads the relocation table from the maintenance track into the RAM. The relocation table is available to the Host system through the READ-RELOCATION-MAP command.

#### 4.3.4 Write Protection

Each disk contains a write protect hole which is normally covered by a small tab. When the operator wishes to prevent the disk from being written on, the tab is removed allowing a photo-electric circuit in the drive to sense the hole.

If the AMC receives a WRITE command from the Host for a disk that is write-protected, it returns a status byte to the Host indicating COMMAND-NOT-ACCEPTED and DISK PROTECTED.

#### 4.3.5 Disk Removal Protection

When one of the disk access doors is opened, the heads are retracted from both disks. If this occurs during a read or write operation, an error condition will be generated. In the case of a write, data on one or both disks may be destroyed.

The commands LOCK-DOOR and UNLOCK-DOOR are implemented in the MD 122 to provide the Host system with a means to prevent this occurrence. It is the responsibility of the Host system to issue these commands at the appropriate time.

#### 4.3.6 Media End-of-Life Warning

The drive monitors the usage and performance of all disks. Statistics on disk life are stored in the maintenance tracks. When the useful life of a disk is nearing, the drive reports DISK-EXPIRING status to the Host system so that the disk may be replaced or copied.

The drive also will detect various conditions which will cause damage, or further damage, to the drive if not immediately attended to and, in such cases, reports DANGER status to the Host system. If the disk is not replaced, the drive will operate normally until all 43 relocation sectors have been used. The heads will then be retracted from the disk surface and the drive reports DANGER status and NOT READY.

#### 4.4 Media Life Extension Features

Since all four heads are loaded at the same time and since both disks are rotating at the same time, both disks will wear at the same rate. This is true even if only one, or perhaps neither, disk is being accessed.

To minimize this effect and extend the life of the media, the following features are implemented in the MD 122.

##### 4.4.1 Wear Distribution

When the drive is in the IDLE mode, i.e., no commands are being executed, the servo cruises the heads over the disk surface to distribute wear.

##### 4.4.2 Wear Prevention

If two minutes elapse without any transfers to or from either disk, the drive will retract the heads and stop the drive motor. A command is available to the Host to override this feature. The drive motor will restart and remain running when any door is opened thus insuring that disks are loaded on a rotating spindle to insure proper disk centering.

The heads will automatically retract if there is a loss of disk speed.

#### 4.5 Maintenance Features

The following features have been incorporated in the MD 122 to aid in maintenance of the drive.

##### 4.5.1 On-Board Confidence Test

A confidence test routine is stored in read-only memory (ROM) in the device controller. At power-on time, the AMC executes the confidence test which exercises the device controller and both drives.

Upon completion of the confidence test, the drive indicates results to the Host system via the DEVICE-ATTRIBUTE-RECORD.

#### 4.5.2 Interface Wrap-Around Test

The drive incorporates an interface wrap-around feature which will, when combined with suitable Host system software, allow a customer engineer to quickly isolate a fault to either the Host/interface or the MD 122.

If the wrap-around test fails, the fault is on the interface or in the Host system.

If the test succeeds, the fault is in the MD 122 and further isolation is via the drive stand-alone diagnostics without further Host involvement.

#### 4.5.3 Stand-Alone Diagnostic Tests

The drive has the capability to execute stand-alone diagnostic tests called Maintenance and Test Routines (MTR). These MTR's are capable of isolating a fault to a single printed circuit board in 95 percent of the faults.

### 5.0 FUNCTIONAL CHARACTERISTICS

#### 5.1 Recording Characteristics

Data is recorded on both sides of the disks. The disks are soft sectored and pre-initialized to the format described in paragraph 8.4.

Bit Density:	7100 bits per inch
Track Density:	150 tracks per inch
Areal Density:	$1.07 \times 10^6$ bits per inch <sup>2</sup>
Recording Mode:	Modified Frequency Modulation (MFM)

#### 5.2 Storage Capacity

The following capacities exclude one sector per track and one track per surface reserved for sector relocation as well as two tracks per surface reserved for maintenance purposes.

Data Bytes per Sector:	256
Data Sectors per Track:	44
Data Bytes per Track:	11,264
Data Tracks per Surface:	139
Surfaces per Disk:	2

Data Bytes per Disk:	3,131,392
Disks per Spindle:	2
Spindles per Drive:	1
Data Bytes per Drive:	6,262,784

### 5.3 Performance Characteristics

#### 5.3.1 Positioner Performance

All times given include settling time.

	<u>Seek Time</u>
Minimum:	40 ms
Average:	100 ms
Full Data Track Seek:	200 ms

#### 5.3.2 Rotational Characteristics

Latency times, disk rotational rate, and data transfer rate are as follows:

Average Latency:	57.25 msec
Maximum Latency:	114.5 msec
Disk Rotational Rate:	524 RPM
Data Transfer Rate:	1.0M bits per sec

#### 5.3.3 Time to Access a Data Sector

The total time required to randomly access a data sector is as follows:

Minimum Time:	0 msec
Average Time:	157.25 msec
Maximum Time:	295.65 msec

## 6.0 Physical Characteristics

Figure 1 shows outline details and overall dimensions of the MD 122 Mini Disk Drive. The following table lists the salient characteristics in both English and metric systems:

<u>Characteristics</u>	<u>English System</u>	<u>Metric System</u>
Length	20.50 inches	520.7 millimeters
Height	10.00 inches	254.0 millimeters
Width	5.50 inches	139.7 millimeters
Weight	28 lbs.	12.7 kgm
Shipping Weight	32 lbs.	14.5 kgm

## 7.0 Controls and Indicators

This section describes disk insertion/extraction controls and the status indicators.

### 7.1 Controls

Operator controls consist of a pushbutton for each disk which opens the corresponding door (see Figure 1) and retracts the cone assembly enabling the disk to be inserted or removed.

### 7.2 Indicators

Two status indicators are provided for each disk. The white, ready indicator is illuminated when both doors are closed and the corresponding disk is in place and rotating at the correct speed. The red indicator is illuminated to denote the ability to write data on the disk. The indicator is off when the disk is write protected - achieved by uncovering a small hole in the jacket normally covered with a self adhesive tab. If one particular drive is operational and the other door is opened, then the previously, operational drive will be in a temporarily not available status and white light will flash. If a fault condition should occur with a door open and the heads not retracted, all four indicators will flash in a "ripple through" pattern.

## 8.0 INTERFACE

### 8.1 General

The MD 122 Mini Disk Drive is compatible with the Burroughs OEM Standard Disk Interface as defined in 8.2.

## 8.2 Logic and Semantic Interface

### 8.2.1 Logic Interface

The logic interface is defined in the Logic and Semantic Interface Specification (refer to paragraph 2.0).

### 8.2.2 Semantic Interface

The semantic interface is a full implementation of command, status and system integrity functions listed below. For a complete description of these functions refer to the Logic and Semantic Interface Specification (refer to paragraph 2.0).

#### 8.2.2.1 Commands

The commands listed in Table 1 are fully implemented in the MD 122 Mini Disk Drive.

#### 8.2.2.2 Status Functions

Status information is reported by the drive controller to the host controller as required by the Logic and Semantic Interface Specifications. The status functions implemented are shown in Table 2.



Table 1 - Command Summary

	Commands	Requires Seek	Requires Data Transfer
Group 1	Read		
	Read Statistics	x	x
	Read Location Map	x	x
	Write	x	x
Group 2	Search	x	x
	Read Search Result		x
	Read Device Attribute Record		x
	Read Status		x
	Host Receive MTR		x
	Host Send MTR		x
Group 3	Abort Device Controller		
	Abort Drive		
	Inhibit Motor Stop		
	Set Write Protect		
	Reset Write Protect		
	Unlock Door		
	Lock Door		

Table 2 - Status Summary

	BYTE 1	BYTE 2	BYTE 3
Bit 0	Drive Address Bit 0, Least Significant	Error	Not Ready
Bit 1	Drive Address Bit 1	Search Unsuc- cessful	Disk Expiring
Bit 2	Drive Address Bit 2, Most Significant	Corrected	Write Protected
Bit 3	Transfer Delay	Command Not Accepted	New Disk
Bit 4	N Sectors Before Read	Command Error	Danger
Bit 5	N Sectors Before Write	Address Error/ End of Drive	Confidence Test Completed
Bit 6	Operation Complete	Mandatory Inter- rupt to Host	Temporarily Not Available
Bit 7	Interrupt	Address Not Found	Unassigned

### 8.2.2.3 System Integrity Functions

The following system integrity functions are implemented in the MD 122 Mini Disk Drive.

- a. Retry on read error.
- b. Correction of read error.
- c. Relocation of defective sectors.
- d. Protection of system from disk removal.
- e. Detection of disk end of life.

### 8.3 Electrical and Mechanical Interface

The electrical and mechanical interface is defined in the Implementation Interface Specification (refer to paragraph 2.0).

### 8.4 Data Format

The data format is defined in the Formatted Disk Specification (refer to paragraph 2.0).

## 9.0 RELIABILITY AND SERVICE GOALS

### 9.1 Reliability

#### 9.1.1 Mean Time Between Failure (MTBF)

The design MTBF is as follows:

Drive and Basic Electronics	2150 hours
Device Controller	5000 hours

NOTE: The design MTBF is calculated from failure rate predictions using MIL Standard #217B.

#### 9.1.2 Media Life

Minimum disk life is  $2 \times 10^6$  revolutions on any track with the heads loaded, and  $1 \times 10^7$  revolutions overall. The drive incorporates features designed specifically to extend media life (refer to paragraph 4.4).

#### 9.1.3 Error Rate

The maximum irrecoverable rate is 1 error in  $10^{11}$  bits transferred.

Recoverable errors and seek errors are handled completely within the drive by the AMC and are noticeable to the Host system only as a minimal decrease in throughput.

## 9.2 Service Goals

### 9.2.1 Preventive Maintenance

No preventive maintenance is required.

### 9.2.2 Mean Time to Repair (MTTR)

The MTTR is a function of maintenance philosophy. With a PC board replacement strategy, the MTTR should be less than 0.75 hour. With a component replacement strategy, the MTTR should be less than 1.5 hours.

### 9.2.3 Service Life

Service life for the unit before factory rework or replacement is required is 7 years or 14,000 hours of actual operation time, whichever occurs first.

## 10.0 INSTALLATION

### 10.1 Power Requirements

The unit requires the following D.C. power for the electronic circuits and for the drive motor:

<u>Voltage*</u> (VDC)	<u>Current, Maximum</u> (Amperes)	<u>Current, Minimum</u> (Amperes)
+5	10.0	4.5
+12	7.0	0.5
-12	3.5	0.5

NOTE: \* All voltages are measured at the D.C. power connector on the drive.

If the power supplies exceed the tolerances, the unit will shut down. When the supplies return to normal levels, the system will conduct a standard power-up sequence; no special switch-on sequencing is required. Supply variations +10%-5% on all lines. Noise limits are as follows:

50 mV RMS 1 Hz to 10 mHz on + 5 V maximum

100 mV RMS 1 Hz to 10 mHz on  $\pm$  12 V maximum

Noise spikes may not cause the voltages to exceed the supply tolerances.

### 10.2 Grounding Requirements

Threaded insert provided on card cage.

### 10.3 Environmental Requirements

The environmental limits specified for the drive are classified as operating conditions and non-operating conditions.

#### 10.3.1 Operating Conditions

Relevant environmental operating conditions include: temperature and humidity, shock and vibration, radio frequency radiation, atmospheric pollutants, and altitude and barometric pressure.

##### 10.3.1.1 Temperature and Humidity

The drive will operate reliably in an atmosphere ranging from 13° C to 40° C at 20 to 85 percent relative humidity. Condensation on or in the drive is not permitted. The maximum allowable rate of temperature change is 1° C per 5 minutes. Disks must be stabilized in the temperature and humidity conditions under which the drive will be operating, for at least 30 minutes prior to insertion in the drive.

##### 10.3.1.2 Shock and Vibration

The drive will withstand 0.1 g's peak acceleration in three mutually perpendicular axes over the frequency range of 5 to 500 Hz.

##### 10.3.1.3 Radio Frequency Radiation

The drive will operate reliably in an electric field not exceeding 1 volt/meter rms in the range of 20 Hz to 10 GHz. If the Host system environment exceeds this limit, it must provide appropriate shielding and filtering.

##### 10.3.1.4 Atmospheric Pollutants

The drive will operate reliably in an atmosphere containing not more than 60 milligrams of dust in 1000 cubic feet of air by weight of particles (equal to or greater than 5 micron diameter).

##### 10.3.1.5 Altitude and Barometric Pressure

The drive will operate reliably at altitudes ranging from sea level to 3 km (10,000 feet) and at barometric pressure ranging from 20 to 32 inches of mercury.

#### 10.3.2 Non-Operating Conditions

Relevant environmental non-operating conditions include: long term temperature and humidity, and shock and vibration.

##### 10.3.2.1 Long-Term Temperature and Humidity

The unit will show no deterioration when stored in an area with temperatures ranging between -40° C and +50° C and with a non-condensing relative humidity ranging between 5 and 90 percent.

### 10.3.2.2 Shock and Vibration

When the unit with the actuator secured is packed in approved container, it may be subjected to the following shock and vibration conditions, on each of 3 orthogonal axes, without receiving damage that will prevent installation or hinder operation.

- a. Shock levels of 5 g's impulse for 5 to 50 milliseconds, of 1/2 sine waveshape.
- b. Vibration of 1.5 g's acceleration in a frequency range from 5 Hz to 500 Hz.

### 10.4 Air Flow

To maintain the specified unit operating environment in terms of temperature, a minimum continuous air flow of 70 cubic feet per minute is required. This air flow must be maintained when drive is removed from its normal mounting position for maintenance purposes. Incoming air temperature must not exceed 40° C.

### 10.5 Drive Orientation

The drive must be mounted with the doors (and the disks) oriented to a vertical position as shown in Figure 1. The drive is designed to be built into a Host system which must provide the cooling air, the D.C. operating voltages, and any switches or interlocks needed for personnel safety or for servicing procedures.

### 10.6 Connector

Connection to the Host system input-output subsystem is made via a 60-way stripline connector. The suggested mating connector AMP 1-87733-7 or equivalent.

D.C. power from the Host system is connected to the unit via a power connector. The suggested mating connector Amp type 530521-4 or equivalent.

## 11.0 SAFETY STANDARDS

The MD 122 Mini Disk Drive complies with relevant product safety standards as issued by Underwriters Laboratories, Incorporated; Canadian Standards Association; and other national safety standards, as required.

## 12.0 GLOSSARY OF TERMS

Actual Operation Time (AOT) - The time power is connected to the drive.

Address - A number that defines the location of the smallest addressable unit of data (a sector) in a track on the disk. The address contains track, surface, and sector location information.

Areal Density - A measure of recording density in units of bits per square inch defined to be track density (TPI) times bit density (BPI).

Average Access Time - The time taken for the Positioner to complete all possible seeks (including settling at each location) divided by the number of possible seeks.

Bits per Inch (BPI) - The number of bits (unformatted) recorded per linear inch on the innermost data track.

Byte - Eight bits of data.

Data - The information transferred to and from the Host system and read back from or recorded on the disk.

Disk - A flexible Mylar<sup>R</sup> disk 8 inches in diameter. The disk has pre-recorded alignment tracks and sector headers.

Error Correction Code (ECC) - A coding system that permits the detection and correction of errors in the data.

Failure - Any unplanned occurrence within the drive that prevents operation according to the specification.

Format - The arrangement by which data is written on the disk with certain code words, address words, etc. structured in a specific way.

Head - The magnetic element used to write and read data to or from the disk. The same head is also used to read the servo information.

Header - A set of data that is pre-recorded and serves as the sector mark for the soft sectoring. The header contains the preamble, address mark, address, error correction code, status, closing statement and gap.

Idle State - The normal state of the drive when waiting for a new instruction.

Interface - The definition of the means by which the Host controls the drive. This consists of the electrical signal levels and their sequence and the interpretation of those signals.

Latency - The time interval needed to arrive at any sector on a given track assuming no Positioner movement.

Maintenance and Test Routines (MTR) - The formal list of tests that can be applied to the drive or subassemblies of the drive to establish which parts of the drive are non-functional and to confirm that their replacement or repair has eliminated the fault. They are prepared on the assumption that the drive was working prior to the fault and that only one fault exists.

Maintenance Tracks - Special tracks not normally available to the Host system. They contain such items as the relocation list, the number of retries, the correction algorithms, and the relocated sectors.

Mean Time Between Failures (MTBF) - The mean of the actual operation time between failures measured after the first 200 hours but before 10,000 hours of operation have elapsed.

Mean Time to Repair (MTTR) - The average number of hours required to repair a failure, including time for diagnosing, repairing and testing the drive. The MTTR figure assumes that repairs are performed by trained personnel with the proper tools, documentation, and repair parts and does not include the time to determine that the fault lies in the drive.

Noise Spike - Any transient disturbance on the power lines.

Preventive Maintenance (PM) - The maintenance scheduled to be performed on the drive to increase the probability that no parts will fail during the actual operation time.

Relocation - The re-establishment of a sector to a spare location when the sector is found to contain an irrecoverable error. This re-establishment is accomplished within the drive and is normally transparent to the Host system.

Sector - The smallest addressable unit of data on a track, 256 bytes.

Seek - The act of moving the Positioner to a new track location.

Seek Error - When the Positioner goes to the wrong track location during a seek operation, or when the Positioner exceeds its positional tolerance after the settling timeout.

Servo Track - A reserved track carrying a pre-recorded signal that enables special circuits to use the head in the read mode as a position transducer.

Settling Time - The time needed in a Seek for the head to come to a stable position on a track within the permitted position error.

Soft Sectoring - A method of detecting sectors on a track by means of Headers pre-recorded on the disk; as opposed to hard sectoring whereby the sectors are detected photoelectrically via holes in the disk.

Syndrome - A set of words produced by the error correction code circuits at the end of the sector when a sector of data was read and the read data was checked by these circuits. The words are non-zero if an error is detected; they are used in the error correction process.

Tag - A set of words held in a data buffer and compared with data in a sector. The tag is a Host-supplied parameter of the SEARCH command.

Track - One 'circle' of data accessed by a head at any one of the Positioner discrete positions.

Tracks per Inch (TPI) - The average radial density of the data tracks, being the total number of tracks divided by the radial distance over which they are located.





