

Digital Design

The Magazine of Systems Electronics

LATEST SEMICONDUCTOR TECHNOLOGY

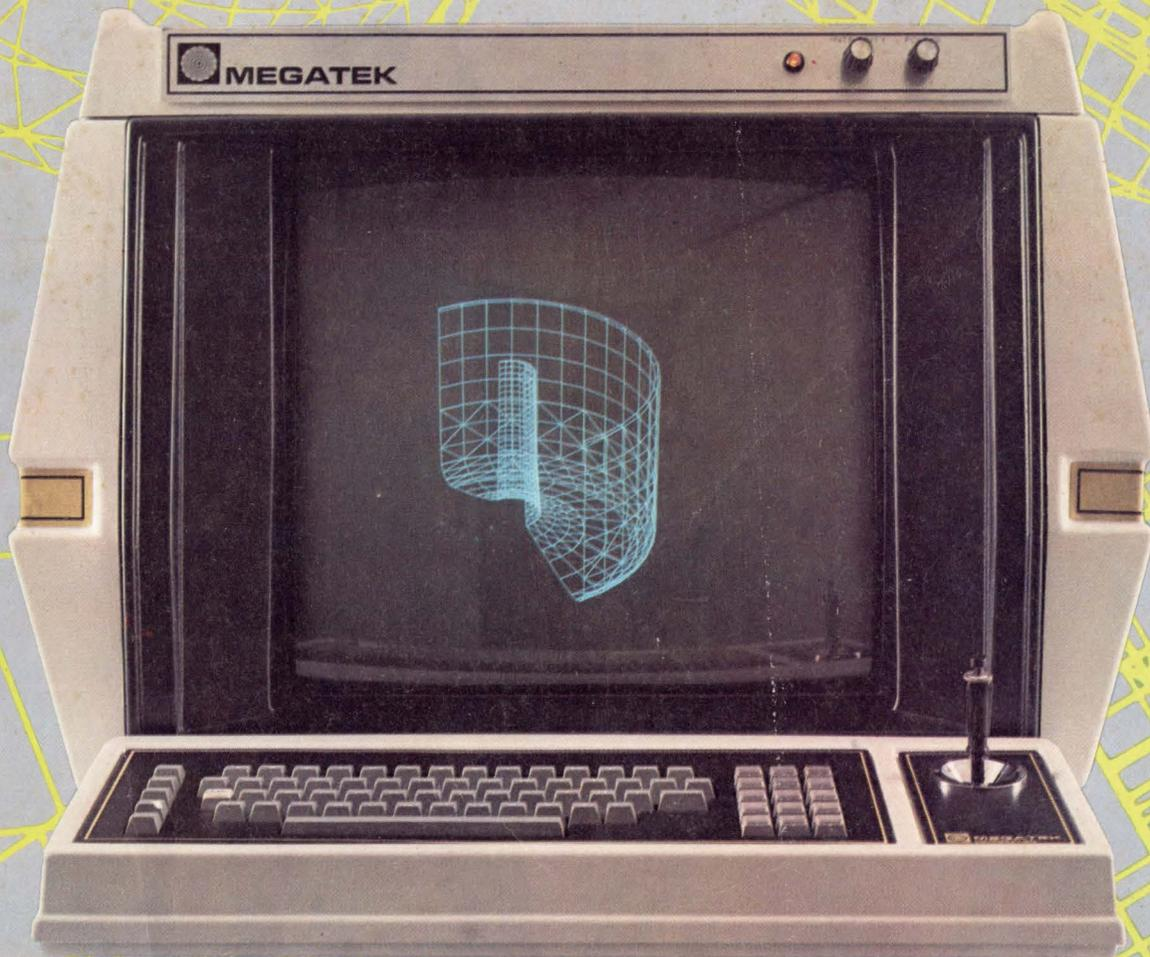

Selecting a CRT ?
µP Development Systems

For Your Mini
Maintenance

25109



Our Wildest Card Yet

A programmable 16-line multiplexer that beats everything in its class*



PDP-11 users, we have another winner for you.

This time it's DMAX/16™, our new programmable multiplexer for connecting your PDP-11 to 16 asynchronous serial communications lines. DMAX/16 makes the most of the 11's DMA capabilities to establish computer overhead at a level far below that of competitive units like the DJ11 and DZ11. It also offers software compatibility with the DH11... in one-fourth the space!

Now, for the first time, you don't need an expansion box or special back planes. DMAX/16 consists of two hex boards which install easily into standard SPC slots and connect to the current loop or EIA/RS-232 panel by separate flat-ribbon cable. As many as 16 units can be placed on a single PDP-11 for a total of up to 256 lines. A DMUX/16™ option allows modem control for 16 channels.

DMAX/16 provides complete program control of the lines, each of which operates with several individually programmable parameters, such as character length and number of stop bits. Parity generation and detection are odd, even or none. The operating mode is half duplex or full duplex.

Fifteen software programmable baud rates: 0 to 9600 baud — plus 19,200 baud — and an external baud rate. Breaks may be generated or detected on each line and the unit can echo received characters without software intervention.

Play the wild card now. You'll get top performance and a competitive price advantage of at least \$1000 along with delivery from stock as usual.

Write for details and find out why we consider ourselves the leader among manufacturers of DEC enhancements.

Able Computer Technology, Incorporated,
1751 Langley Avenue, Irvine, California 92714.
(714) 979-7030. TWX 910-595-1729

Able, the computer experts

DEC and PDP-11 are registered trademarks of Digital Equipment Corporation.

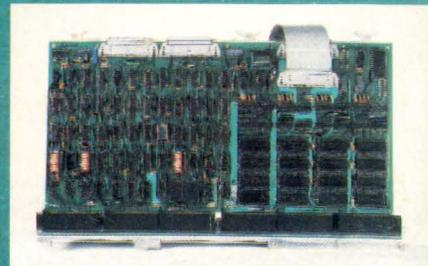

*You will save half your bandwidth or run at twice the speed! Able does it again!

Circle 1 on Reader Inquiry Card

μ P μ P and away

Going μ P? Our 8-lane universal expressway to μ P development is wide open.

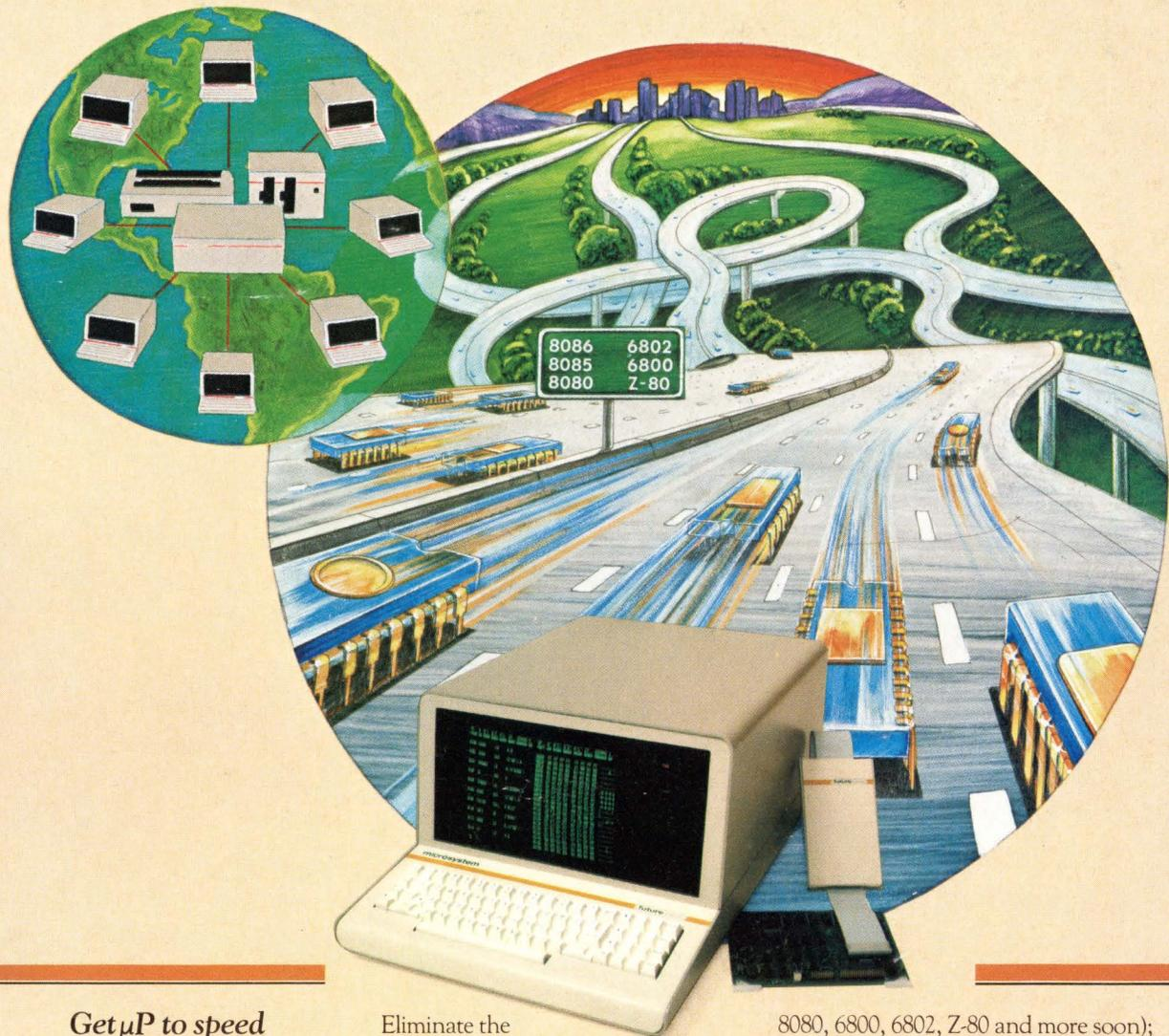

**Get μ P to speed
with our multistation
development network.**

Eliminate the traffic jam in your microprocessor development lab. Get off that one-way road to μ P-based product design (with just one chipmaker's microprocessor support) and reduce your per-station cost at the same time. How? With our Universal Multistation Development Network — a distributed processing system that shares disk and printer with up to eight users simultaneously. Give each user his own AMDS station with integral CPU, CRT and keyboard; any one of six supported processors (8086, 8085,

8080, 6800, 6802, Z-80 and more soon); optional in-circuit emulator, logic analyzer and every software aid, including BASIC compilers, relocating macro-assemblers and disassembling symbolic debuggers. It's the first sensible alternative to the high cost of multi-user development support and confining single-chip systems. Futuredata, 11205 S. La Cienega Blvd., Los Angeles, CA 90045. (213) 641-7700 TWX: 910-328-7202.

futuredata

Circle 4 on Reader Inquiry Card

The Bantam.

The cocky new \$599* CRT that just changed the pecking order.

User Need	Feature	P-E BANTAM	LSI ADM-3A	Hazel- tine 1400	Hazel- tine 1500	Adds Regent 100
Easy to read display	7 x 10 matrix for highly legible characters	Yes	No	No	Yes	No
	Black on white or white on black display	Yes	No	No	Yes	Yes
	Display set deep in hood to reduce glare	Yes	No	No	No	No
	Full 24 x 80 display	Yes	Yes	Yes	Yes	Yes
	Full upper and lower case	Yes	Option	No	Yes	Yes
	Non-glare screen	Option	Yes	No	Yes	Yes
High operator throughput, low operator fatigue	Tab stops/tab key	Yes	No	No	Yes	Yes
	Backspace key	Yes	No	No	Yes	Yes
	Repeat key	Yes	Yes	No	No	Yes
	Shiftlock key	Yes	No	No	No	No
	Separate print key	Yes	No	No	No	Yes
Convenient switching Local/on-line	Local - remote key	Yes	No	Option	Option	Yes
International Character sets	French/German/ Swedish/Danish/ British/Spanish	Option	Option	No	Option	Option
High speed numeric	Integrated numeric pad	Yes	Option	No	Yes	Yes
Convenient system interfacing	RS-232/CCITT-V24	Yes	Yes	Yes	Yes	Yes
	Current loop	Option	Yes	No	Yes	Yes
Simplified program debugging	Transparent mode and displayable control characters	Yes	No	No	No	No
Faster maintenance	Self-test	Yes	No	Yes	No	Yes
Minimum desk space	Small size	15Wx 19Dx 14H	15.5Wx 20.2Dx 13.5H	15.5Wx 20.5Dx 13.5H	15.5Wx 20.5Dx 13.5H	21Wx 23Dx 14.5H
Printer port	Printer port	Option	Yes	No	Yes	Option
Cost effectiveness	Qty. 100 OEM price	\$599†	\$740	Less than \$550 in quantity 1000	\$860	\$895

*In quantities of 100.

†Qty. 1, End User Price \$966.

Nobody ever offered you a tough, high quality, compact CRT like the BANTAM before. At \$599 or any price. Designed for hectic office environments. And, human engineered to make an operator's life easier.

You get everything you need for cleaner input and faster throughput. An upper and lower case character set displayed on a sharp 7 x 10 dot matrix. A full 24-line by 80-character screen. A complete, sure-touch keyboard with shadow numeric pad.

You get complete tabbing. Full cursor addressing. Repeat, backspace and shiftlock keys. A transparent mode with displayable control characters to simplify host program debugging. And, a self-test mode for easy maintainability.

And, you get everything your operators need to make their jobs a joy. A hooded display that cuts glare. A wide bandwidth monitor for sharp images everywhere on the screen. Below-the-line character descenders' to make reading easier.

A switchable white-on-black or black-on-white display, whichever your operator prefers. An easy-to-find cursor that frames the entire character position in a transparent, inverted video block.

Plus plenty of options you can't get with CRTs costing much more. Like our low-cost Pussycat page printer. A full range of foreign language character sets. We even have a model you can switch from ASCII to full overstrike APL.

But that's not all. The BANTAM's compact good looks fit any decor. It's handsome enough for executive row and rugged enough for the stockroom. Silent? The BANTAM's fan-free design makes it quieter than an electric typewriter. And, the BANTAM only weighs 28 pounds.

Only an industry leader like Perkin-Elmer could do it. We designed a powerful, custom LSI controller chip that makes the BANTAM the one and only high quality CRT in its class.

But see for yourself. Use the comparison chart. Learn why we're so proud to add this \$599 CRT to the 250,000 peripherals that bear our good name.

And, remember our terminals come equipped with a No Hassle, 800 toll-free service phone number.

One call does it all. We give you service *where* you need it, when you need it. We're there. Not just "worldwide," but wherever you are.

For more information call or write Perkin-Elmer Terminals Division, Randolph Park West, Route 10 & Emery Avenue, Randolph, N.J. 07801 (201) 366-5550. Or contact any of our sales offices. Then watch the feathers fly.

The Bantam's available at all these places

PERKIN-ELMER SALES OFFICES

Santa Clara, CA (408) 249-5540.

Tustin, CA (714) 544-9093.

Atlanta, GA (404) 393-8440.

Arlington Heights, IL (312) 437-3547.

Waltham, MA (617) 890-1305.

Oceanport, NJ (201) 229-4471.

McLean, VA (703) 827-5900.

Singapore, Republic of
Singapore 2200949

Sydney (North Ryde), Australia
887-1000.

Toronto (Mississauga), Canada
(416) 677-8990.

Slough, England 753-34511.

Paris, France 664-1858.

Munich, Germany 089-753081.

Schiphol-Oost,

The Netherlands 020-458-269.

PERKIN-ELMER SERVICE CENTERS

Randolph, NJ; Oceanport, NJ; West Long Branch, NJ; Rochester, NY; Boston, MA; Hartford, CT; Philadelphia, PA; Pittsburgh, PA; Washington, DC; Atlanta, GA; Orlando, FL; Cleveland, OH; Dayton, OH; Englewood Cliffs, NJ; Detroit, MI; Chicago, IL; Minneapolis, MN; Kansas City, KS; Tulsa, OK; Dallas, TX; Houston, TX; Denver, CO; Phoenix, AZ; Seattle, WA; San Francisco, CA; Los Angeles, CA; Orange County, CA; San Diego, CA.

PERKIN-ELMER
Data Systems

Circle 5 on Reader Inquiry Card

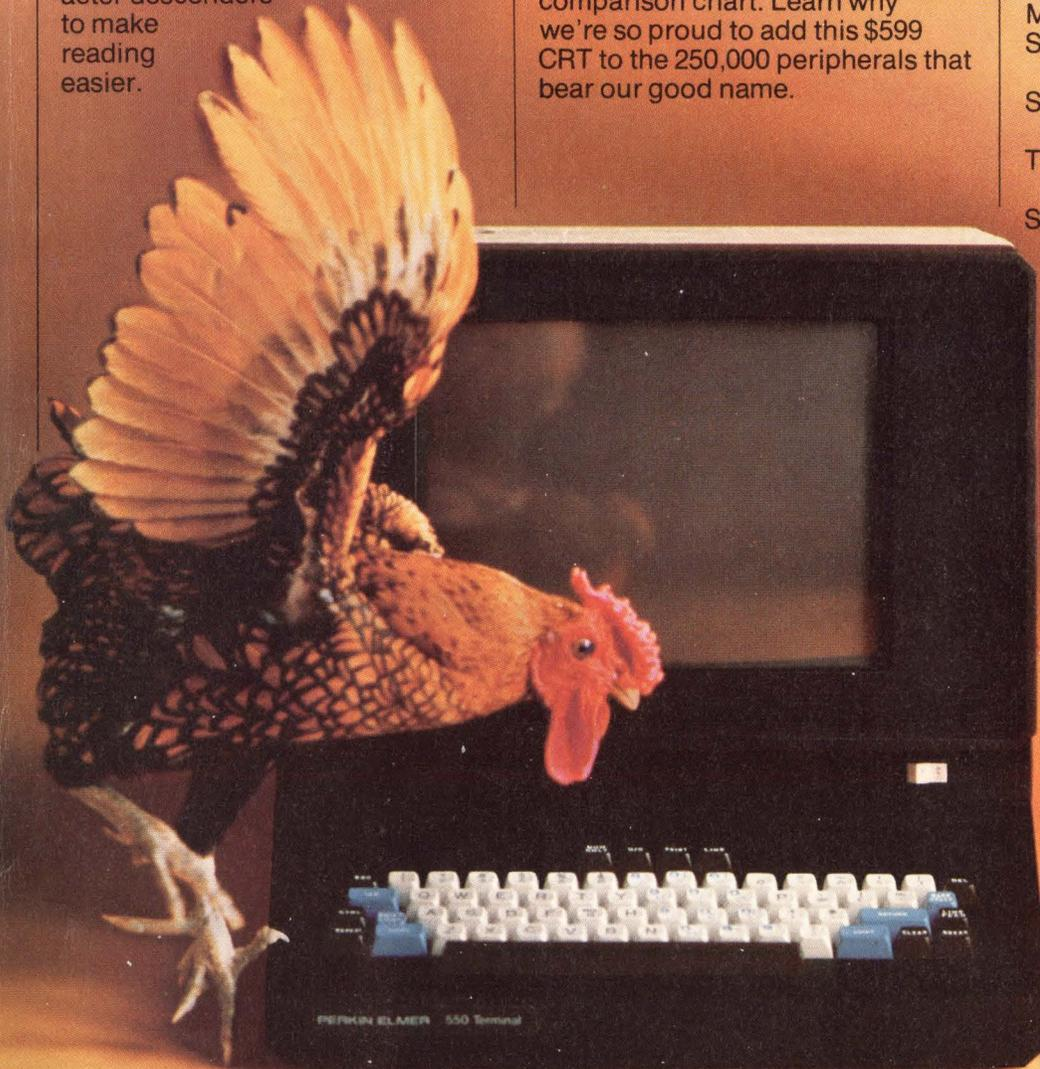

Grinnell has your display...

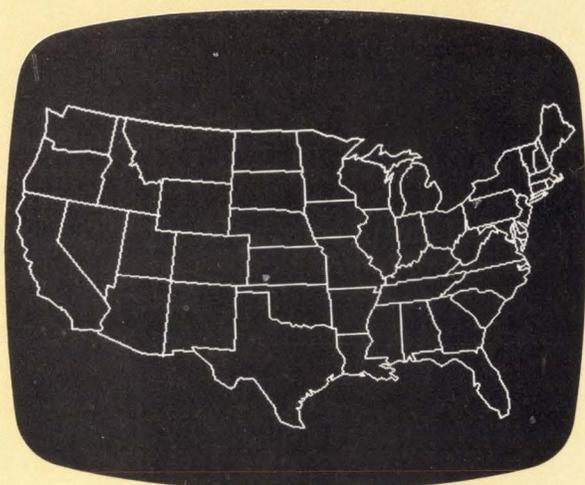
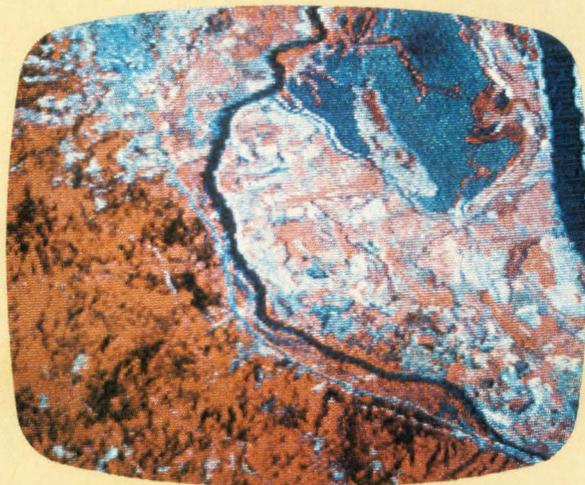
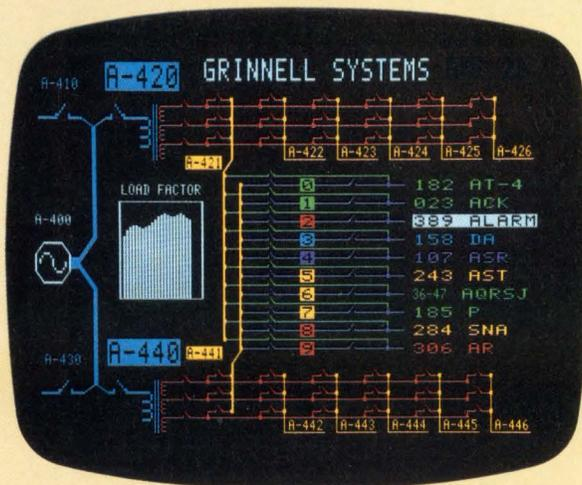

from low cost imaging and graphics to full color image processing

Our modular, solid state systems can meet your computer display requirement, easily and economically.

And, they're intelligent. Every system has a complete alphanumeric and graphics package, and a powerful instruction set that simplifies programming—no need for complex macro-instructions and high order programming languages.

There's also a choice of standard resolutions: 256 x 256, 256 x 512, 512 x 512 (30 Hz or 60 Hz refresh) and 1024 x 1024. Plus plug compatible interfaces for most minis.

Options include overlays, function memories, pseudo-color tables, zoom and pan, independent cursors with trackball and joystick controls, split-screen, image toggling, and real time digitizers that grab and store images and sum consecutive frames.

Grinnell displays are already used for tomography, ERTS imaging, process control, image processing, animation and much more. All systems drive standard TV monitors.

So before you choose a display system, let our experts show you how to maximize performance and minimize cost. For details, and/or a quote, call or write.

GRINNELL SYSTEMS

2986 Scott Boulevard, Santa Clara, California 95050 (408) 988-2100

Features

- 28 **Choosing a Higher Level Language for μ P Development Systems**
Selecting an MDS isn't as straightforward as it seems; and, in selecting a high-level language, it's good to keep in mind changes in design philosophies that have shifted emphasis from old schemes to new, before making your choice.
- 36 **Selecting a CRT Terminal? Characteristics need careful matching**
Recent design features, increased reliability, greater intelligence and lower costs — all these and a myriad of technologies and models make comparisons difficult. Here's some help in this task.
- 44 **Latest Semiconductor Technology Offers Users More Speed, Flexibility and Standardization**
State-of-the-art semiconductor technology in graphics systems achieve performance that exceeds that of older, higher-priced designs.
- 56 **Need Mass Storage for Your Mini? Try 1/4" Cartridges**
Computer systems require substantial mass memory. Here's one way to add that mass memory at reasonable cost.
- 84 **Magnetic Media Maintenance**
While magnetic media maintenance isn't new, new techniques and variations offer improvements. Although of prime interest to end-users, magnetic media maintenance is also important to designers and system engineers, who must be aware of the latest developments. Seven industry experts help clear up misconceptions.

Departments

- 8 **Letters**
- 10 **Speakout**
- 12 **Technology Trends**
- Intel Software Supports 16-Bit 8086
 - Microprocessors Promise New Age of Invention
 - Videobrain Home Computer Adds User Programming Capability
 - A New Contestant Enters the 16-Bit Single-Chip μ C Arena
- 20 **Software Design Series**
- 60 **Designers' Notebook**
- Half-Chip Direction Decoder for Quadrature Pulses
 - A Simple Digital Pulse-Programming Circuit
 - Calculate Pseudorandom Sequence Lengths
- 62 **Product Highlight**
Intel's ANS 78 BASIC
- 64 **New Products**
- 95 **Advertiser's Index**
- 96 **Viewpoint**

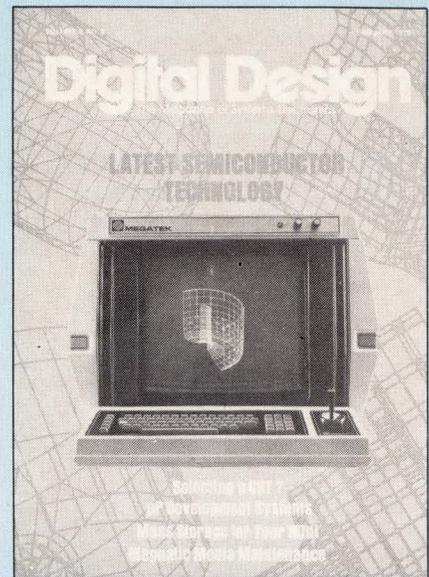

ON OUR COVER

The Whizzard 7000 consists of a number of independent modules connected by an asynchronous tri-state bus structure, allowing for future expansion and OEM-added, optional hardware. Megatek provided this imaginative photo and accompanying article (pg. 44).

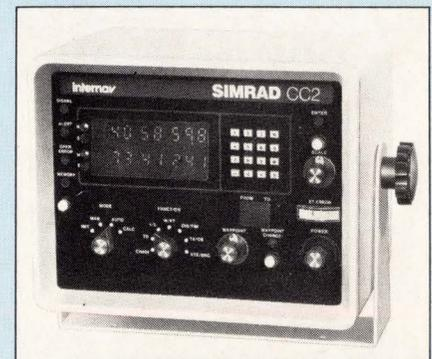

DIGITAL DESIGN

Publication Number: USPS 407-010

Published monthly by Benwill Publishing Corp., a Morgan-Grampian Company, 1050 Commonwealth Ave., Boston, MA 02215. Application to mail at controlled circulation rates is pending at Long Prairie, MN 56347. Copyright © Benwill Publishing Corp. 1979.

New! Model 640 Low Cost* Loader Reads 350 Characters per Second

All solid state photo-electronic components.
Reads all standard 5,6,7 or 8 level tapes.
Smooth, quiet, AC drive.

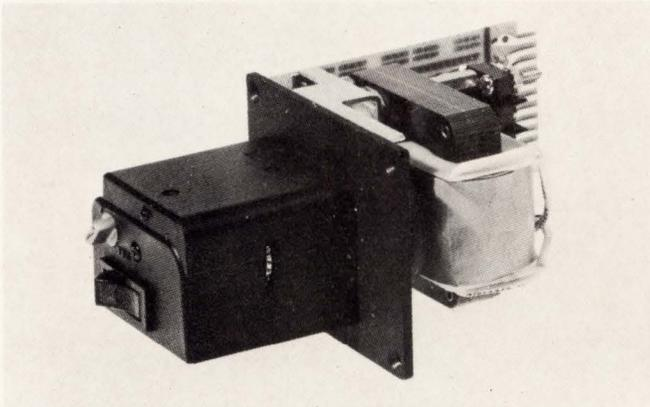

Provides reliable, high speed data entry. Data amplifiers and "character ready" output available for CMOS or TTL interfaces. Fanfold box available.

The Model 640 is the newest addition to the Addmaster line of quality paper tape equipment.

*Only \$166-189! (1-49 units; substantial quantity discounts available.)

Addmaster Corporation, 416 Junipero Serra Drive, San Gabriel, California 91776. Telephone: (213) 285 1121.

Circle 7 on Reader Inquiry Card

PADLA™
the INTERDATA interface solutions
QALTA™

for full RS232 modems
MACROLINK's Programmable Asynchronous Dual Line Adapter provides two full RS232C channels in a single half-board. Twice as many channels in the same space at almost half the cost — \$800* (U.S.A.), including 7 1/2-foot internal cable with two DA15P connectors and complete instruction manual.

for local loops
Quad Asynchronous Local Terminal Adapter gives you four local communications channels on a single half-board at about half the power of one PALS channel. \$675* (U.S.A.) includes 7 1/2-foot internal cable with four DA15P connectors and complete instruction manual.

*Both PADLA and QALTA are plug-to-plug compatible with all Interdata computers replacing expensive PALM/PALS add-ons. OEM discounts available.

PADLA and MACROLINK are trademarks of MACROLINK, Inc. Interdata is a registered trademark of Perkin-Elmer Corporation.

macrolink
(Formerly ROV Engineering)
1740 E South Anaheim Blvd.
Anaheim, CA 92805
(714) 535-4500

Circle 8 on Reader Inquiry Card

Digital Design

The Magazine of Systems Electronics

Publisher Yuri R. Spiro
Editorial Director George King
Editor Paul Snigier

Managing Editor Vic Farmer
Special Projects Editor Israel Katz
Associate Editor William Belt
Assistant Editor Katsuzo Suzuki
Art Director Richard D. Sarno

Staff Artists
Mike Barisano David Bastille
Steve Fischer Sookyun Rha
Susan Ross Donni Richman

Production
Joe T. Ingram Sarah Jewler

Circulation
Sue Duchin David L. Harriman
Sheila McDonagh Regina Harrington

Editorial Assistants
Cheryl Dunphy Patricia Mangano
JoAnn Pangione Kathy Shank

General Administration
Sarah Binder Esther Shershow
Marion Pearlman Marlene Stibal
Don Schaaf Jonna Yager

Editorial Offices
Publishers Office: (213) 478-3017
Western Office: (714) 675-7123
Eastern Office: (617) 232-5470

SUBSCRIPTION POLICY

DIGITAL DESIGN is circulated only to qualified research, development and design engineers in all branches of industry, government institutions and universities. To obtain a complimentary subscription, request (on company letterhead) a qualification card from Circulation Director. For change of address; attach old address label from recent issue to new company letterhead or note telling us what your old address was; send this plus request for new qualification card to:

Circulation Director
DIGITAL DESIGN

1050 Commonwealth Ave., Boston, MA 02215

Subscription rates: Domestic subscriptions for non-qualified subscribers, groups, libraries or companies, \$25.00 per year. International Subscriptions, \$35/year.

DIGITAL DESIGN solicits editorial material and articles from engineers and scientists. Contributors should submit their manuscripts in duplicate and typed with two spaces between lines. All illustrations should be clear; components on all schematics and line drawings should be labeled. The editors assume no responsibility for the safety or return of any unsolicited manuscripts.

BPA CIRCULATION: 58,788
(JAN., 1979)

Published monthly by Benwill Publishing Corporation, Harold G. Buchbinder, Chairman of the Board; George Palken, President; Domenic A. Mucchetti, Treasurer. Executive, Editorial and Subscription Offices, 1050 Commonwealth Ave., Boston, MA 02215. Telephone (617) 232-5470.

OUR PDP-11* MAGTAPE CONTROLLER IS GOOD AS GOLD

every two hours of
every working day
somebody puts
a TC-130 on a
PDP-11 computer

Here are just a few of the reasons why more people put TC-130's on their PDP-11 systems than any other magtape controller:

- Software compatible - embedded design
- Mixed density - 1600 bpi PE and 800, 556, 200 bpi NRZ
- Intermix 9 track and 7 track, up to 8 drives
- Fits all PDP-11 Series Computers
- Dual speed - switch selectable, 12.5 to 125 ips

SEND FOR COMPLETE INFORMATION



western peripherals

Division of WESPERCORP

(714) 991-8700 • TWX 910 591-1687
Cable WESPER

1100 Claudina Place, Anaheim, CA 92805

Western Peripherals Service Centers
located in:

Anaheim, California (714) 991-8700
Wheaton, Maryland (301) 949-0401
Lewisville, Texas (214) 436-5577
Zeist, Netherlands 03404-21344

* Trade name of Digital Equipment Corp.

LETTERS

μP Packaging Options

Dear Editor:

Carol Ogdin and Robert Cobaugh's article, "New Microprocessor Packaging Options" in the October and December issues were well written and long overdue in this field. To be sure, engineers are encountering unique and unexpected problems, but no other magazine I know of has addressed these problems (much less offered engineers any solutions) before your article.

Robert Krell
Camden, NJ

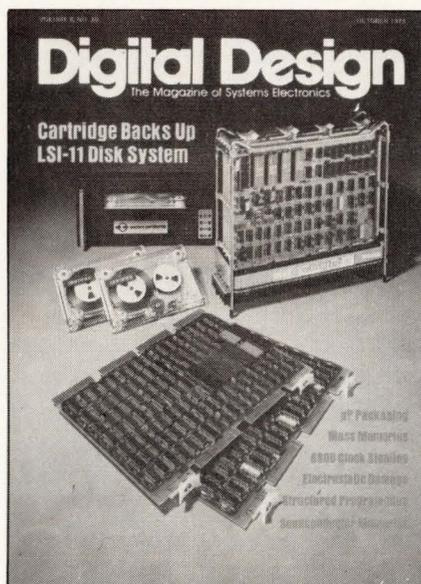

Stands Corrected

Dear Editor:

I was pleased to see the two-part article that I and Robert Cobaugh wrote for your October and November issues ("Special Design Guide: New Microprocessor Packaging Options").

One minor thing: I would appreciate it if you'd check the bio on page 76. I would think the appropriate word in the second sentence would have been "have," not withstanding the fact that I've only received one Neal Award.

Carol Anne Ogdin
Software Technique, Inc.
100 Pommander Walk
Alexandria, VA 22314

Ed. Note: We stand corrected: it was one and not two. In addition to Carol's two new books we mentioned

in the bio – "Microcomputer Design" and "Software Design for Microcomputers" – her newest book, "Microcomputer Management and Programming," will be published (also by Prentice-Hall) early in 1979.

Likes AIOU

Dear Editor:

In your October Speakout, "Nothing is Impossible," you stated that "Although not a true mail-order university, American International Open University awards PhDs without previous degree, formal work or attendance requirements and has no full time faculty." You said that "Awarding degrees for experience sounds noble. Should we see more of it?"

Yes, I agree. I feel that we should see more of such schools. There are more technicians who deserve degrees but cannot find time to attend engineering college, so it is an idea whose time has come.

Robert Channey
Bristol, RI 02809

Wants a Degree

Dear Editor:

Several months ago in your Speakout column titled "Nothing is Impossible,"

Disk Cleaning Suggestions

Dear Editor:

Paul DeVivo's article in the November, 1978 issue of Digital Design entitled "New Magnetic Disk Cleaning Methods", did not acknowledge design practices that prevent head/disk failures attributed to contamination. Hermetic sealing and proper air flow have been shown to be the most effective insurance to this potential problem in disk drive units.

Our company manufactures spindle shaft exclusion seals that are incorporated in many major disk drive units. Ferrofluidic[®] technology provides an absolute hermetic seal which stops migration of volatile bearing lubricant components (a critical contamination source) and airborne particulates from entering the disk cavity. These seals utilize a magnetic fluid coupling that offers the spindle designer advantages over conventional elastomeric bearing seals and older labyrinth restriction

you stated that anyone can get an engineering degree from American International Open University. Will you mail me the address of the school? Thank you.

H.V. Victor
Plain View, NY 11803

Ed. Note: To set the record straight once and for all for those who wrote or called us, asking for more information, we never said "anyone" could get a degree from AIOU – requirements exist. Nor did we advocate AIOU or any other "open university." We merely stated that "American International Open University awards PhDs [and other degrees] without previous degree, formal work or attendance requirements, and has no full-time faculty. Seven prominent IEEE members are also AIOU faculty members, and at least one obtained his doctorate from this university. Is this a new way to get degrees?" We then stated, "Awarding degrees for experience sounds noble," and asked: "Should we see more of it?"

Such open universities do provide advantages and are a new concept. On the other hand, will abuses result? Does it "cheapen" engineering degrees from traditional engineering schools? Are federal regulations needed to keep the new open universities honest? Or from spreading like weeds?

designs. Since mechanical work is done in fluid shear, power consumed in the seal is minimal, thus resulting in lower bearing operating temperatures and extended lubricant life. Additionally, these seals do not generate any wear particles which could become a source of contamination. Users report particle counts below normal operating specs, and head disk failures are minimized.

In severe operating environments, the disk cavity is filled with a positive pressure inert gas. Ferrofluidic seals are also used in this application. Seals with pressure capability are an extension of the company's product base in rotary feedthroughs that penetrate vacuum pressures while maintaining absolute seals to the atmosphere.

A copy of a Ferrofluidics' technology to disk drives is enclosed for your reference and is available to your readers who contact me.

Jerome J. Schaufeld
Ferrofluidics Corp.,
Burlington, MA 01803

Tandberg Data improves the tape drive.

SO WHAT ELSE IS NEW?

Versatility. On an absolutely new level.

With the name Tandberg you expect top performance. Innovation. And versatility. And being a little ahead of the competition in certain fresh and subtle ways. Ditto our new TDI 1050 Synchronous Tape Transport. When you're a Johnny-Come-Lately with a product line you'd *better* try harder. We did!

Your benefit? Greater reliability, maintainability, and programmability as a result of our microprocessor-based control logic. With its optional *internal* formatter, the 10-1/2-inch-reel TDI 1050 makes your interfacing task a whole lot easier, giving unprecedented flexibility and performance when controlling the reading and writing of data.

With Tandberg's dual-format tape drive, you get both 1600 cpi PE and 800 cpi NRZI at speeds of 12.5 to 45 ips, with rewind speed of 200 ips. And there's no need for customer redesign with the industry-wide compatibility of our interface.

For those who'd like multiple-drive capability in their system, our interface enables you to hook up *four* drives without the need for an outside power source.

Not only is the TDI 1050 less costly at the outset, but its built-in microprocessor is likely to reduce your operating costs. Its attractive design is another appealing plus for systems builders.

A few other goodies are our 5,000-hour MTBF, a dual ceramic-blade tape cleaner, and our proven microprocessor control



system. A choice of 7 or 9 track. And IBM geometry provides minimal dynamic skew. Also, a fully documented maintenance manual with all the data and schematics necessary for easy and economical upkeep.

Ensuring you get the performance we specified for our drive, we put each unit through an exacting series of computer tests and burn-in, far tougher

than any challenges it's likely to encounter on the job.

Just another tape drive? Yes and no. The task it performs has been around a while. A lot of horses ran a mile and a quarter and then along came Secretariat. Refinements count a lot, regardless of the track. Check out the TDI 1050. It'll change your ideas about what a tape transport can do.

CONTACT: Gary Pyles, Sales Manager
Tandberg Data Inc., 4060 Morena Blvd.
San Diego, California 92117
Telephone (714) 270-3990

Also available now as the Model TDI 1050 Binary Data Logger (BDL), connected typically to RS-232C communication interfaces. Rugged, amazingly simple, and featuring sequenced power-fail recovery, the TDI 1050 BDL from Tandberg Data provides highly compact, non-attended 1600 cpi phase-encoded or 800 cpi NRZI digital data-logging capability suitable for communications systems activity records.

TANDBERG

SPEAKOUT

Paul Snigier, *Editor*

WHAT NEXT?



The IEEE election is history now. Voting was mediocre, petition candidate and reformer Irwin Feerst lost again (but will try again), and despite strong opposition from the working EE, \$100k/yr Bruno O. Weinschel (owner of 444,386 shares and head of Weinschel Engineering Co., Maryland) was re-appointed as Vice President of Professional Activities to fight *for* the working engineer – for patent and pension reform, and against age discrimination and wage busting. Some say that no problem exists; others, that progress is slow but sure; and others call for reform, claiming that university deans and IEEE

business executives will find it difficult to avoid conflict of interest and oppose their own financial interests.

“What can be done about this?” asks Feerst in the December 1978 newsletter of the Committee of Concerned EEs (Box 19, Massepequa Park, NY 11762). He then states: “If you renew your IEEE membership, do so for only six months – Option E on the renewal form. Who knows? Members may shortly be presented with a *new organization* that will represent *them* – and not the clique of college professors and corporate executives that dominate our lives Make no mistake about it – there will be no peace within IEEE until it is led by professionally-minded reformers dedicated to elevating the professional lives of the American engineer. And we don’t mean Board-encouraged members who, under the guise of advocating change, seek merely to split the dissident vote.”

But are these criticisms valid? If so, should the IEEE change? And is a new national organization (also offering a good deal on life insurance) really the answer?

In our past Viewpoints and Speakouts, we’ve presented both sides. But this time, we want *your* opinion. We also welcome your comments on the subject. Circle the new Reader Inquiry Card Numbers (front side) corresponding to your views, and we will report survey results in a future issue.

	YES	NO	UNDECIDED
• Does IEEE need a major reform?	21L	21M	21H
• Is there much chance of reform?	22L	22M	22H
• Should reform efforts be abandoned?	23L	23M	23H
• Would you favor a new organization?	24L	24M	24H
• Are you an IEEE member?	25L	25M	

P.S. To serve you better, you’ll notice two new changes: 1) a new Reader Inquiry Card with lines for “Comments” (this is your direct line to the editor’s desk); and 2) an “Article Evaluation” matrix (1-27 LM L M H and 28 a-i) for conducting polls and rating articles. If you like an article, circle H (High); if not, L (Low).

THE IMAGE ARRAY PROCESSING SYSTEM

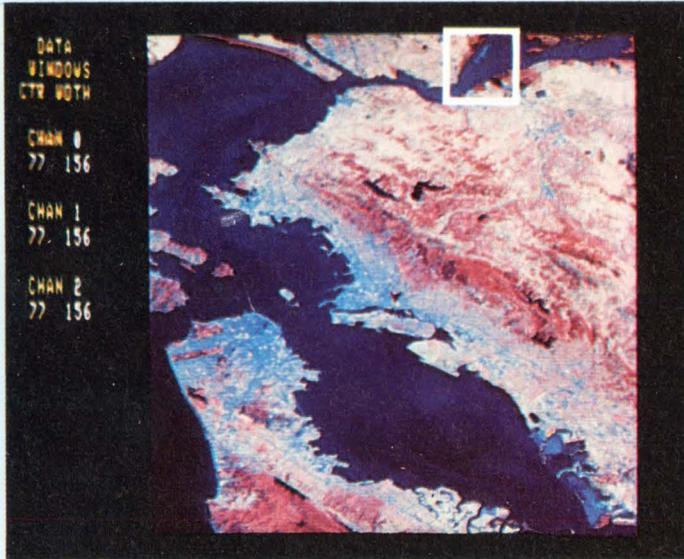

Three band LANDSAT image of San Francisco Bay

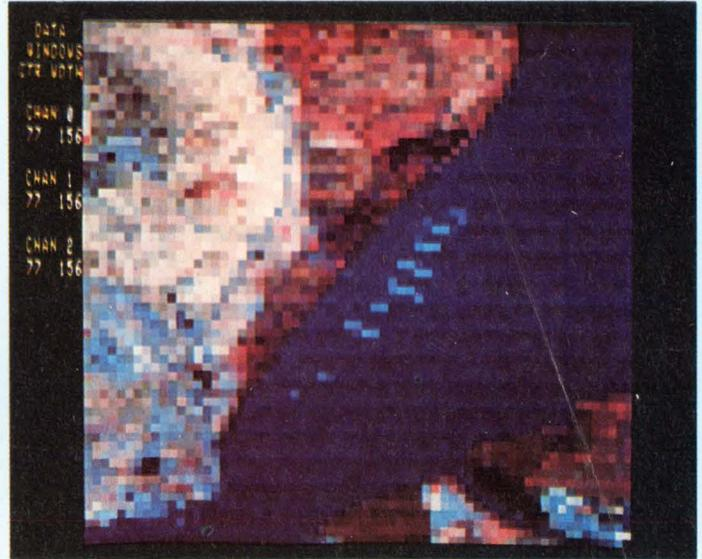

Eight-to-one zoom of Suisun Bay

If image analysis and aquisition is your problem, you need the IP 5000 Image Array Processor.

The display system that:

- Stores up to one megabyte of data for single or multiple image arrays.
- Has complete independence between refresh memory (raster scan output) and host computer addressability of memory.
- Includes memory management and data control for direct high speed access to refresh memory.
- Includes a powerful, pipe-line processor to perform high speed image array processing and statistical analysis.
- Performs pixel replica zoom of 2:1, 4:1 or 8:1 in real time.
- Can selectively change format between 525 line and 559 line video formats with external sync capability for 525 line formats.
- Is capable of scrolling, in any direction, a pixel or line at a time or multiple pixels and lines without causing tearing of the visible image.
- Digitizes video signals up to 8-megahertz bandwidth with true 8-bit precision.
- Has multiple intensity transformation tables for grey scale, color or pseudo color displays.
- Has proven reliability with field installation at some of the top names involved in image processing and display.

For further information and a list of satisfied users,
contact DeAnza Systems, Inc., 118 Charcot Ave.,
San Jose, CA., 95131, (408) 263-7155.

De Anza Systems Incorporated

GIVE YOURSELF A BETTER IMAGE

Intel Software Supports 16-Bit 8086

A Software package which provides complete support for the development of 8086 system programs lets users develop programs in Intel's structured high-level programming language, PL/M-86, or in the 8086 assembly language. The package provides a conversion utility program to convert previously developed 8080/8085 assembly language source programs to 8086 assembly language source code. Converted 8080/8085 assembly language modules can be linked together with newly developed ASM-86 and PL/M-86 programs, and programs written in PL/M-80 for the 8080 or 8085 can be recompiled in PL/M-86 with little or no conversion, so that thousands of assembly language and PL/M-80 programs developed for the MCS-80/85 μ Ps can be readily converted to run on 8086 and on the 8086-based iSBC 86/12 single-board computer systems.

The 8086 software development package, operating on an Intellec 800 or Series II Microcomputer Development System, provides the user total 8086 software development capability.

Upward compatible hardware/ software cuts costs

The Intel 8086, announced in mid-

1978, is a new generation of microprocessor designed to provide ten times performance of the 8080. It incorporates features never before found in a μ P. For example, it can address up to 1 Mbytes of external memory and supports 16-bit hardware multiply/divide instructions. However it was also designed to be 8080A/8085 8-bit instruction compatible and offer a powerful new set of 16-bit instructions.

Provided with the 8-bit instruction compatibility, Intel designed the software to be upward compatible from the 8080A/8085. Both 8080 and 8085 programs or portions of programs written in assembly language can be converted into 8086 assembly language using a software utility called CONV8. As mentioned above, PL/M-80 programs are also transportable to the 8086 through simple recompilation. Therefore, system designers can reduce program development costs by using the applicable parts of programs they have developed before.

Learning to program in a new computer's instruction set is normally a significant factor in moving a design from one computer to another. However, with the 8086's design compatibility, the system designer familiar

with the 8080 or 8085 can move designs to the 8086 with confidence. He will have already accomplished much of the work toward learning to implement software designs for the 8086.

Another cost factor in developing software is the expense of development systems. The 8086 software however, operates on existing Intellec Microcomputer Development Systems — either Series II or the earlier Model 800. For users of these systems, addition of 8086 development software does not require significant hardware reinvestment or retraining.

Therefore the upward compatibility, hardware and software, the ease in learning the expanded language, and the use of existing development systems can save thousands of dollars and untold man-hours when upgrading from 8-bit to 16-bit microprocessors. Companies can move to the 8086 when its capabilities are needed in a natural progression without major upheaval.

High-level language

PL/M-86 is an advanced, structured high-level programming language designed to support the key hardware

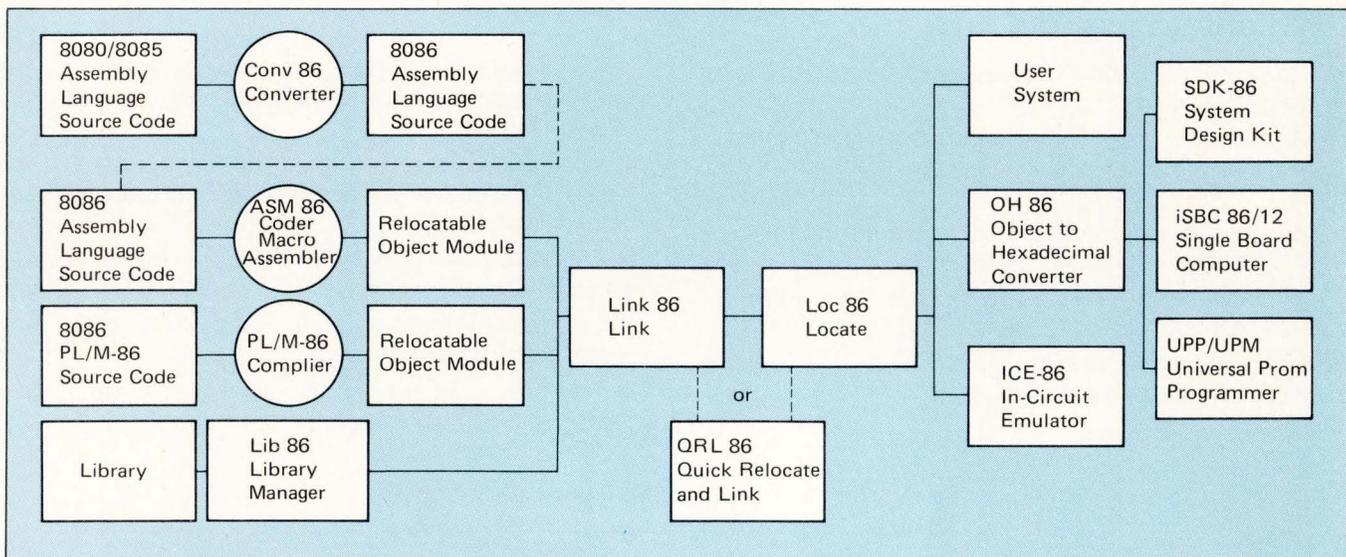

The Intel MDS-311 software package provides software for the 16-bit 8086 and includes the 8086 Assembly Language, PL/M-86 high level programming language and facilities for converting 8080/8085

programs to the 8086. Other programs in the package provide for linking and locating programs developed in modules, managing a library of routines and converting machine codes to printable hex.

Self Portrait of a very remarkable impact line printer.

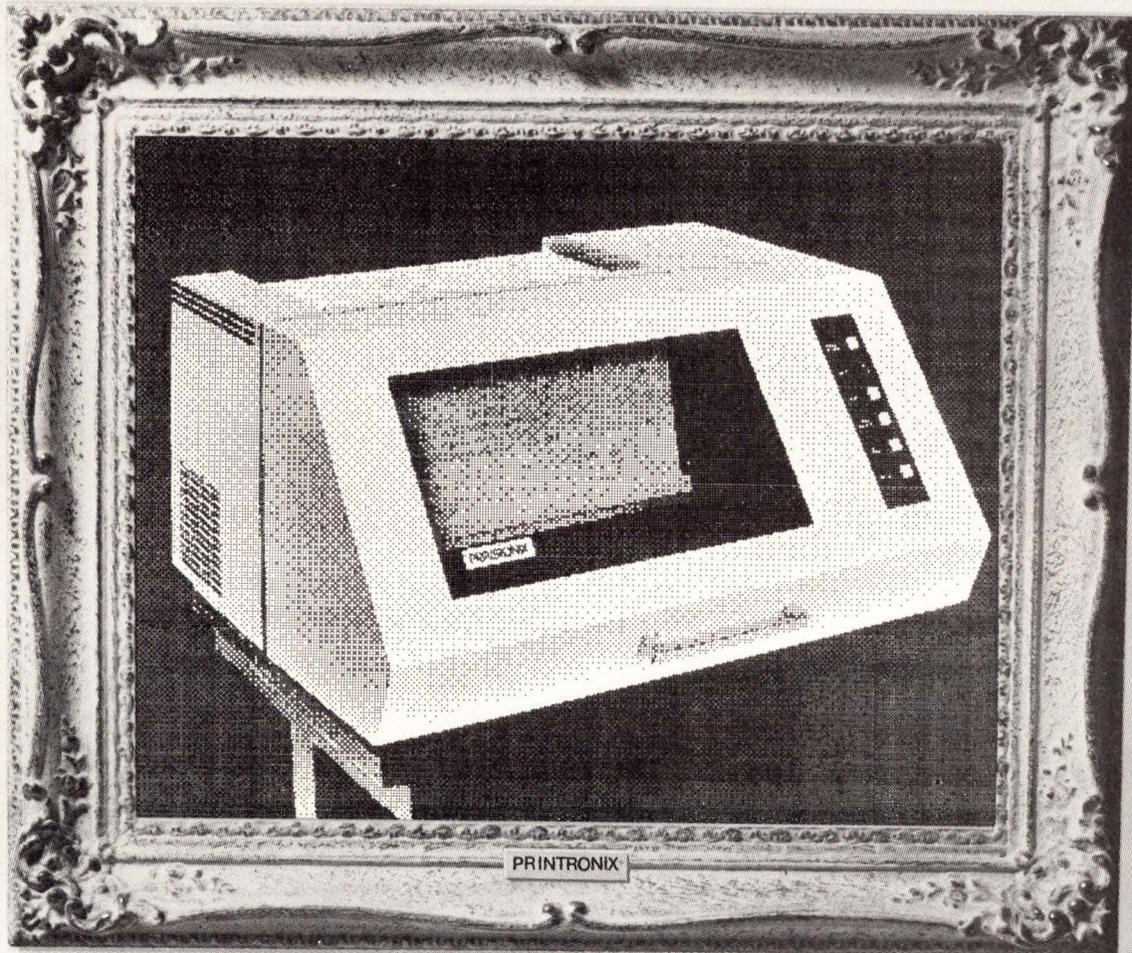

It's a picture worth a thousand words about Printronix impact matrix line printer versatility and cost/performance value.

When the Printronix elegantly simple printing mechanism was conceived, it was determined that its primary role in life would be to produce multi-copy print quality no other impact printer could match, with far greater reliability than other matrix, drum, chain or belt line printers. It has done just that, as proven by more than 5000 units in the field.

But that's only half the picture.

As the "self portrait" shows, Printronix printers can also print drawings, graphs, charts, large characters, bar codes . . . any plotting you may need for a complete distributed data capability.

Other matrix, drum, chain or belt line printers can't do both. Yet a Printronix printer/plotter costs about the same, or less, than an alphanumeric printer alone.

Contact us for complete information on our 150, 300 or 600 lpm printer/plotters. Get a clear picture of the money you can save! Printronix, Inc., 17421 Derian Ave., P.O. Box 19559, Irvine, CA 92713. (714) 549-8272. TWX:(910) 595-2535.

PRINTRONIX

The picture of performance!

features of the 8086. Programs written in PL/M-80 are generally transportable to the 8086. However, PL/M-86 is a new compiler created specifically for software development for the 8086.

PL/M-86 is generally easier to learn than assembly language, especially for the novice programmer. It facilitates rapid program development and lowers program development costs through increased programmer productivity, and software design reliability. PL/M-86 has been designed to aid in the development of reliable software through the use of block structured procedures consisting of simple statements. Programs written in PL/M tend to be modular and self-documenting. They are easier to read and understand and therefore easier to maintain and enhance.

PL/M-86 represents a major refinement and expansion of the PL/M language used by many μ P designers since 1973.

Assembler features "high-level" capabilities

Assembly language programming is normally used when high efficiency or code compaction is needed. Direct manipulation of μ P instructions and hardware features allow its use to design routines that require critical time/space encoding.

The ASM86 Assembler encourages well-designed, well-structured programs. The ASM86 mnemonics are descriptive and compact with most mnemonics representing several distinct machine instructions. During the assembly process, ASM86 builds the completed machine instructions, taking into account the type of the operands used with the assembler Op code. For example, a move instruction would be translated into the exact machine code depending on whether the operands following were 8-bit bytes or 16-bit words, and whether they were in registers, memory, etc. Although many of these intelligent context-dependent translations, called code macros, are included in the instruction set, the user can add his own or delete unwanted ones. The use of code macros simplifies the language, improves coding efficiency and allows the programmer to concentrate on the specific problem — not on learning machine code formation.

The MCS-86 Assembly Language is

"strongly typed" — which means that it performs extensive checks on variables and labels, thus assuring that each use of a symbol conforms to the usage defined when the symbol was first encountered. "Strong typing" helps to detect and prevent programming errors.

The assembly language also includes extensive string manipulation capabilities, a powerful equate facility to allow complex functions to be represented by a single symbol, and a detailed set of error messages. The ASM-86 assembler significantly simplifies coding and permits very sophisticated design goals to be achieved through straightforward use of the language.

Programming in modules

The PL/M-86 language and ASM86 assembler produce code in relocatable modules to allow the designer to subdivide complex programs into smaller, simpler components. He can choose Assembly Language for some parts and PL/M for others, selecting the language most appropriate for specific tasks. He can develop and debug each module before combining them into one program, or several programmers can develop different parts of the final program in parallel.

The development package provides the relocation (Locate) and linkage (Link) software needed to combine these modules and to position and locate the modules, thus permitting the modules to be developed with or without concern for the final memory locations. They are then combined and relocated to make the best use of available memory.

During program development, a rapid view of how programs fit and run is frequently desirable. To do this the 8086 software package includes a QRL (Quick Relocate and Link) facility, an abbreviated version of Link and Locate, combined into one pass. It is a debugging tool which assists in program development. It allows the designer to work on a module and see that it runs before combining individual modules into a single executable program.

Two other programs provided in the development package are an Object Code to Hexadecimal Symbolic Object Code Converter and a Library Manager. The Object Code-to-Hex-Converter — which translates absolute machine language object code generated by the system into printable hexadecimal symbolic object code — is often useful during debugging to print out machine language and contents of memory in a readable form.

The Library Manager™ program allows designers to build, maintain, and use libraries of assembled or compiled programs, modules and routines. These are then coupled into the program under development through the Link or QRL programs. The Library Manager helps the designer to organize these modules, simplifying the retention and use of previously developed material.

The package (order # MDS-311) costs \$3,400. This includes deskettes, manuals covering installation, operation and programming, plus one year of updates.

For more information, **Circle 158** on the Reader Inquiry Card.

A New Contestant Enters the 16-Bit, Single-Chip μ C Arena

Joining Intel, Zilog and Fairchild's entries, Motorola's MC68000 provides 32-bit-wide internal architecture, 16 32-bit registers (8 for address functions; 8 for data). Being housed in a more costly 64-pin package (and with its 16 data and 24 address pins) means one thing: that the MC68000 is aimed at mC and not just μ C-type applications, all of which comes as no real surprise when we look at MC68000's 2M instructions/sec and 400K words/sec data transfer

rates.

Although work continues on a family of peripheral support devices, MC68000 is compatible with existing peripheral devices, so this proves no problem for users. A PASCAL interpreter and compiler, which lend themselves to MC68000's high speeds, are both in the works. Since interpreters facilitate error tracing during debugging programs, this will reduce PASCAL software development times. — **Snigier**

Fast, Hard Driving . . .



And a Proven Track Record!

Toggle rates to 10MHz-40ma of output drive power. We call it the ULA Digital Bipolar Gate Array and it's fast enough to interface with computers and strong enough to drive LED's and other external devices. And five years of competition have proven that ULA has the ruggedness, reliability, and radiation resistance to wheel in the toughest technical circles.

Compatible with either TTL or CMOS, ULA can accommodate both digital and linear circuitry.

Over 2000 uncommitted components let you shrink your circuit size while reducing assembly costs and improving system reliability. And with three different configurations available, ULA is an ideal approach for upgrading your packages and products to 1978 standards.

Design Your Own Custom IC—The new ULA Design Kit will show you how. For only \$59., you get circuit design guidelines, component characteristics, functional adhesive overlays, and

layout sheets. And after your I.C. layout is complete, we'll integrate it for \$2800 and deliver 20 prototypes in 4 to 6 weeks.

Get your products on track with ULA. Write or call if you need information but better yet, order your ULA Design Kit today!

interdesign
A FERRANTI COMPANY

Interdesign, 1255 Reamwood Ave., Sunnyvale, CA 94087, Tel: 408-734-8666.

Circle 13 on Reader Inquiry Card



VideoBrain Home Computer Adds User Programming Capability

The VideoBrain Computer Co. has introduced the APL/S Computational Language cartridge to make the basic VideoBrain system programmable. With APL/S a user can perform complicated business, financial, scientific and mathematical computations with minimal effort, because this version of APL is tailored for use ease.

In addition, elements unique to APL/S help the programmer newcomer feel comfortable with a computer language while fully using its features to develop customized programs.

One feature of APL/S is array capability: groups of numbers can be handle as one variable. Thus, when an operation such as multiplication, is to be performed on several elements in a group, only one step is needed to have the multiplication operate on all elements automatically. This feature vastly reduces program steps needed to execute many common computational tasks, such as computing a stock portfolio value or using Newton's method to solve a cash flow problem, or countless other such problems.

In addition to array capability, APL/S also features structured control words which makes it easy to write, change and debug programs in a logi-

cal straightforward manner.

APL/S, a derivation of APL, is a mathematical system developed by Kenneth Iverson at Harvard and designed so a user's concept of a par-



The APL/S Computational Language cartridge lets the VideoBrain user perform complicated business, financial, scientific and mathematical computations. Users can use preprogrammed cartridges or develop their own programs and store them for future use and reuse on an ordinary cassette tape recorder.

ticular problem lets him form the program in a straightforward manner.

This makes VideoBrain suitable for learning because the short, neat, logical programs of APL/S allow VideoBrain users to concentrate on a problem's abstract aspects without worrying about superfluous and complex computer notation. Thus, users focus on stock portfolio analysis or an engineering algorithm — not the program itself. Similarly, the "Immediate Mode" of APL/S allows users to easily execute some elaborate computations without writing a formal program.

Where many home computers offer computation using only integers, this APL has a floating point package, allowing clear broadrange manipulation of large groups of numbers.

VideoBrain lets users store APL/S programs and data using VideoBrain Expander 1 and an ordinary cassette tape recorder, providing for the use and reuse of programs.

VideoBrain will continuously publish tapes and books to accompany the VideoBrain owner's use of APL/S. Introduction of the APL/S program brings to twenty the total number of VideoBrain cartridges available by year-end.

For more information, **Circle 159** on the Reader Inquiry Card.

Microprocessors Promise New Age of Invention

The microprocessor is a solution seeking problems. Rapid gains in micro-computer technology have paved the way for thousands of new products.

A society of gadget and toy lovers with increasing incomes and leisure time will encourage μ C designers and their firms to find new applications for μ P technology. Frank Seabury of Arthur D. Little, Inc., in Cambridge, MA, who leads the consumer portion of a study on business implications of changing μ C technology, anticipates an exciting new age of invention and innovation spurred by μ Ps, but warns that the failure rate will be high. The study, completed this February, projects new μ P product types likely to emerge in the next decade.

Among the many possibilities, Arthur D. Little researchers foresee a programmable door chime which, ac-

cording to the programmer's whim, will ring out "Jingle Bells" or "Beethoven's Fifth"! On the practical side, controls for lawn sprinklers and home lighting systems will be timed and operated by intelligent electronics using presketched programs or commands from sensors. Seabury also predicts the market for electronic games—the hottest Christmas items of 1978—will increase six times by 1987.

As for consumer acceptance of electronic products, two major questions emerged from the Arthur D. Little study: 1) Is there an appetite for the endless array of μ C-controlled products? 2) And can the consumer afford them? "The answer to both questions is a resounding yes," said Seabury.

The ADL study shows that consumers will add to rather than replace

their store of "toys." Boats and the skis will stay, but they'll be used less often as firms introduce an ever-increasing variety of electronic gadgets, gizmos and toys for adults (and children).

But even in the face of this projected consumer willingness to buy intelligent μ P-based electronics, study findings suggest that turning inventions into commercial successes will take work.

ADL consultants are advising their clients that there is potential for a dynamic alliance between the inventor who has correct up-to-date technical μ P expertise and the established business firm with the correct marketing expertise and timing to identify which of the few electronic gimmicks represent profitable products that will succeed.

WILSON EXERCISERS

THE ERRORS STOP HERE

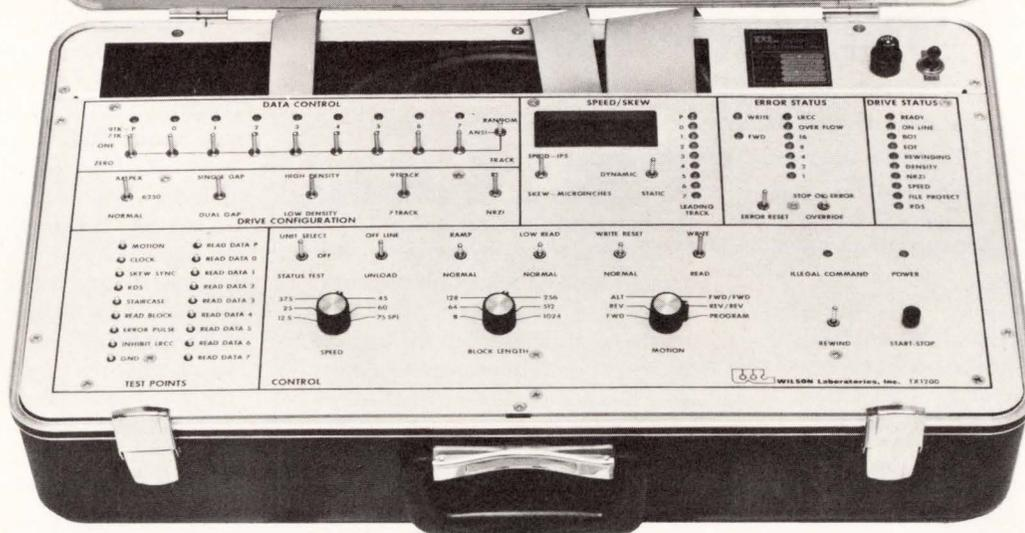

**TX-1200
Tape Drive
Exerciser**

IDEAL FOR BOTH Q.A. AND SERVICE TESTING



**Floppy Disk
Exerciser**

**Disk Drive
Exerciser**

**Tape Drive
Exerciser**

**Communications
Exerciser**

**Storage Module
Exerciser**

**Disk Drive
Exerciser**

**Disk Drive
Exerciser**

To completely test tape drives, disk drives, floppy disk drives and other equipment, you can't beat Wilson exercisers.

These universal Quality Assurance/Service testers are made to check out every operating function that can go wrong.

Wilson exercisers put each unit through its paces — continuously if necessary — to locate even intermittent errors.

Manufacturers, OEM's and Service Engineers rely on these heavy-duty exercisers to catch problems before they can go into a system — or to locate malfunctions that have occurred.

Each standard Wilson exerciser is fully engineered for the equipment it supports, and every exerciser is portable, rugged, reasonably priced and ready to go when you get it. Special needs? We also make custom testers.

Write or Call For Complete Information.

2237 N. Batavia Street
Orange, California 92665
Telephone (714) 998-1980
Telex 181 598

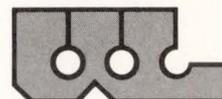

**WILSON
Laboratories, Inc.**

Circle 18 on Reader Inquiry Card

SOFTWARE DESIGN SERIES

Lance A. Leventhal
and William C. Walsh
Emulative Systems Co.



Don't Neglect Program Documentation

Program documentation is surely one of the most neglected states of software development (See "Good Documentation Sells Computers," *Viewpoint*, Digital Design, Dec. 1978). Few books discuss the subject (Ref 1,2) and few courses on programming or software design give it more than a brief mention. How do programmers solve the problem? Typically, they leave all or most of the documentation to the end in hopes that a new interesting project will begin before they are forced to document the one that they just completed! (Another reason for poor documentation is job security.) Managers typically assign a low priority, in terms of time and personnel, to documentation. It's not surprising that documentation becomes the first stage to be shortened or postponed when schedules get tight.

Yet documentation is a vital part of software development, particularly when that software is part of a product to be used for many years. Why? Because during a product's life cycle, far more time, effort and dollars go into test and maintenance than into the initial design. And even within the design and development stages, large amounts of time and dollars go into debugging and testing. You can be certain that good documentation can make everyone's job more difficult. All too often, though, writing poor documentation makes it a lot easier for the manager or programmer-designers — at that time. Unfortunately, the problems caused by poor documentation may later return to

haunt them. (Usually, they're hoping that someone else will later be saddled with these problems!).

Imagine trying to test and maintain a board for which no current schematics, parts lists or manuals exist — especially when the original designer-programmers aren't available or can't remember what they did. If such a board contains software and hardware, then software documentation becomes just as important as hardware documentation. For example, systems like the INTERNAV SIMRAD CC-2 Navigation Computer or the Norland Instruments 3001 Waveform

Analyzer shown here implement few functions in hardware or software exclusively. We will describe the aims and methods of software documentation and provide you with some guidelines for effective documentation.

Who are the users?

Before you approach documenting a product, first ask yourself: "Who is likely to use this documentation and for what purposes?" There are four categories:

- The manager who wants to know the general outline of the software to describe the system to nontechnical personnel, measure progress, identify milestones, divide tasks and ensure that correct procedures are being followed.
- The program writer who wants to identify design problems, mark sections that may require changes and clarify sources of confusion to mark their tracks.
- The program user who wants to know what the program does, what input the program requires, what output it produces, what parameters there are, how he can change them and what incidental effects the program may have.
- The maintenance programmer who wants to know precisely how functions are implemented and how changes can be made.

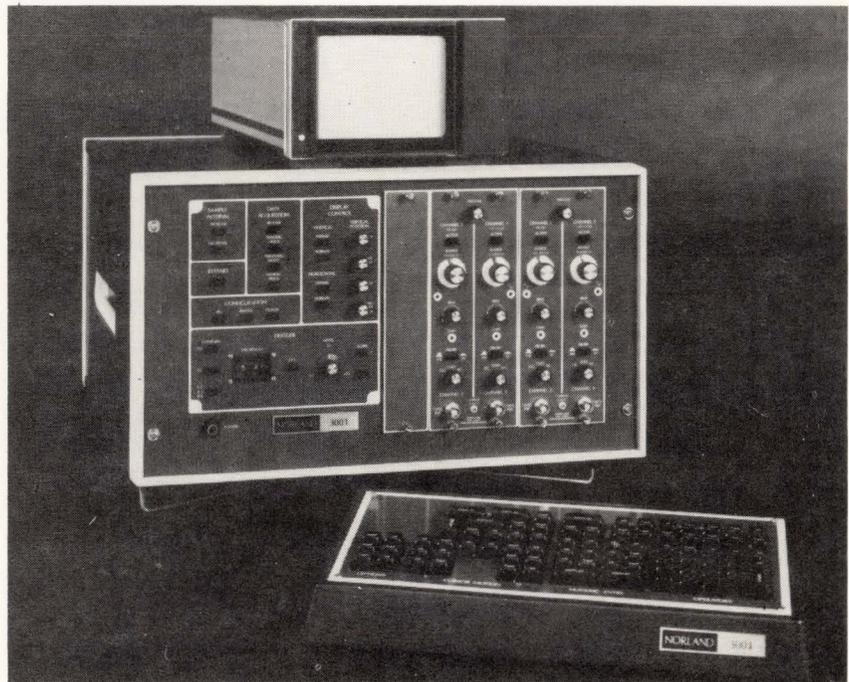

The 3001 Waveform Analyzer. (Courtesy of Norland Corporation, Fort Atkinson, WI)

NEW: An 8mm Dust-Proof Switch from Digitran

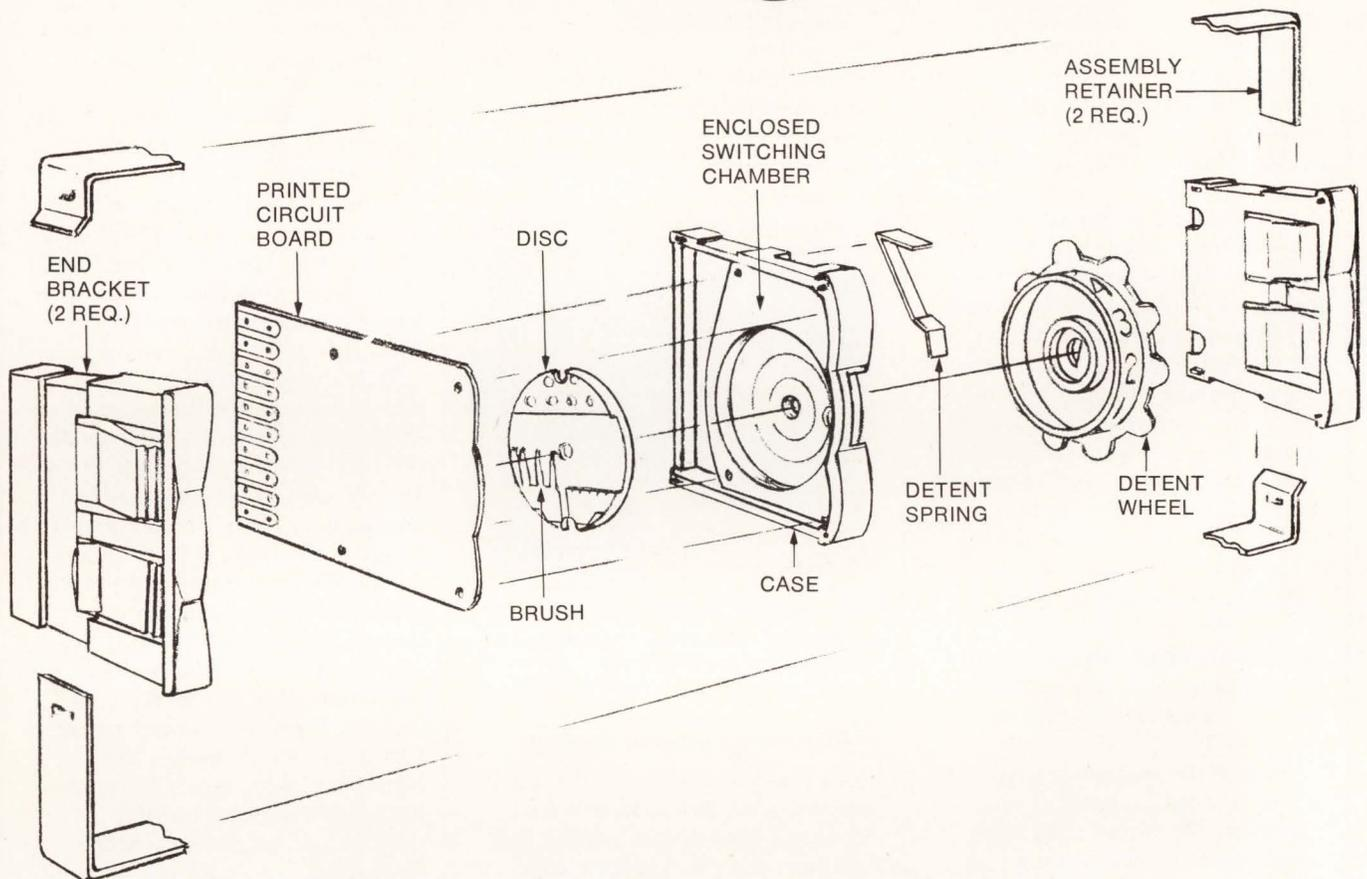

A versatile, high-quality space-saver for \$3.15.

Our new 39000 Series Slimswitch® features an isolated switching chamber for extra protection against dust and debris.

And with a module width of only .315" (8 mm), you save on precious panel space. Yet the up-front characters are .200" high, so they're extra-readable.

This new Slimswitch offers you 10, 11, 12 or 16 dial positions, with field-installable dial stops. Wide choice of output codes and solder or pin terminations. Gold contact system and

G-10 circuit board.

What's more, you can assemble modules without using a single tool. We provide pre-sized, stainless steel snap-on assembly straps.

These great new 39000 Series switches—with all the reliability you've come to expect from Digitran—start at only \$3.15 in 100's.

For the distributor or technical representative nearest you, call toll-free 800-528-6050 (in Arizona, 800-352-0452), Ext. 924. Or contact us directly.

DIGITRAN

The Digitran Company, a division of Becton, Dickinson and Company

855 South Arroyo Parkway • Pasadena, California 91105 • Phone: (213) 449-3110 • TWX 910-588-3794, TELEX 67-5485

Circle 19 on Reader Inquiry Card

What do users need?

From the above you can see how user needs differ very much. The manager doesn't care about the details a maintenance programmer needs. The program writer surely understands the program at the level required by the user. Thus, a complete program documentation package must satisfy users at several levels — the amount of detail required at one level only confuses, bores or irritates those working at another level.

For example, in the case of the navigation computer, why should a manager be concerned with the precise way in which the keyboard and displays are handled? He usually doesn't really care. A programmer who wanted to interface another function to the keyboard or display programs would only want to know what inputs and outputs those programs require and produce, and how they can be called. A maintenance programmer who wished to change the keyboard layout, provide extra display features or change display intensity or error messages, would certainly need to understand the program in great detail.

Now, if the program is large and complex, different levels of users may exist. On the low end, some may just want to know about the simplest features of the program — how to use it for a single, simple task. But on the other hand, others may use the program frequently and wish to take advantage of all its capabilities. How can these divergent needs be met? In one approach used by Integrated Software Systems, the designers of a popular plotting and graphics package called DISSPLA produce different user manuals. The more detailed ones discuss how to perform multiple plots of varied types with different data analysis and display techniques. But the simpler ones just show users how to produce single linear plots.

Good design simplifies documentation

Good documentation practices simplify documentation. Modular pro-

gramming provides modules that you can document separately. Since such structured programming results in repetitive and well-defined logic, it is easy to follow and debug. Top-down design produces levels of separately describable detail. By limiting the flow of information between modules, you reduce the amount of documentation your program requires and the level of understanding needed by both users and maintenance programmers. But good coding practices do more: they simplify documentation with meaningful names, simple and obvious operations order and comprehensibility.



The Internav SIMRAD CC-2 Loran-C Navigation Computer. (Courtesy of Simrad, Inc., Armonk, NY)

The documentation package

Now that we've seen who the users are and what they need, let's look at what a good documentation package must contain. Typical components of a good documentation package include:

- Program flowcharts, as we said in a previous column, may include both a general outline and a more detailed description.
- Data flowcharts which show the sequences of program operations for particular data items.
- Definition and parameter lists which describe all the variables and definitions used in the program.
- Memory maps which describe the amount and type of memory required.
- A user's guide, which may be a single sheet for simple programs that can be included in a general library. (Consider using a standard form.)
- A written description of the program.
- A documented listing of each

program module.

- Structured programs (Ref 3).
- A description of the test plan and results.

There are different ways to use each of these documentation packages. If you're a manager, you can use the general flowchart and written description to obtain an overview of the program. On the other hand, if you're the program writer, you can use the data flowcharts to trace paths through the program and the structured programs to provide a standardized guide to the logic. Or, if you are a program user, you can get information on using the program from the user's guide, memory maps, and definition and parameter lists. And if you're a maintenance programmer, you can use the detailed program flowchart, data flowcharts, definition and parameter lists, and documentation listings to understand program operation details. You will find the description of the test plan and results provide a starting point for correcting errors found in field use.

Should the manager or program user examine the documented listing? Of course not. That listing alone is far from adequate documentation, even if it is fully commented. Note that you can assume that those who do look at the listings are experienced. Thus comments need not spell out the obvious nor describe a particular language or instruction set. Rather, comments should spell out what systems tasks are being performed and how.

Documentation responsibilities

Documentation also creates responsibilities at each of the following four levels:

- Managers must see that proper documentation procedures are defined and followed, and must assign adequate project time and labor to documentation. Be sure that quality control and field service personnel specify early in the design process what documentation they will need.
- Designers must understand documentation requirements at various levels and try to meet them. For documentation to be adequate, you need feedback.
- Users must determine if docu-

Model 820, 150 cps, 80-column, dot matrix impact print mechanism...

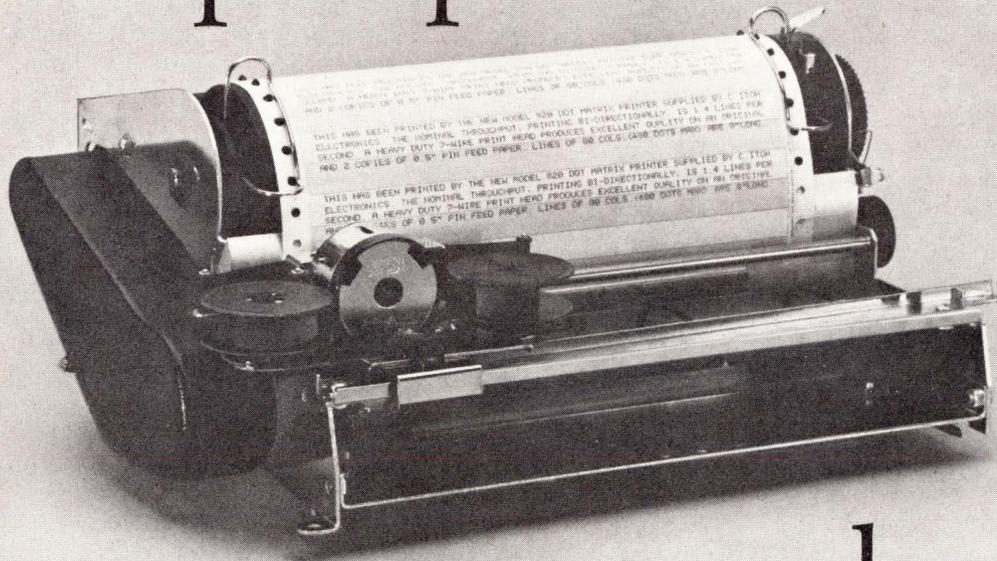

Here's the low cost bi-directional 150 cps print mechanism you've been waiting for. It's an 80-column dot-matrix impact print mechanism with a 7-wire heavy-duty, jeweled head that permits a life of 100-million characters! The mechanism utilizes an extremely simple design to achieve its cost performance and high reliability. It's the perfect OEM unit for computer output, communication terminals, data loggers, and general business applications. A sprocket paper-feed mechanism accepts standard 9.5" wide multi-ply pin-feed paper. Print line position is adjustable vertically, and paper can be loaded from the bottom or from the rear. Price, in quantities of 500, is \$230.00* each. For detailed specifications, write or call today.

and
**low cost
too!**

*Domestic U.S.A. price only.

 **C. Itoh Electronics, Inc.**

5301 Beethoven Street, Los Angeles, CA 90066

Call: 213 390-7778 • Telex: WU 65-2451

East Coast

280 Park Avenue, New York, NY 10017

Call: 212 682-0420 • Telex: WU 12-5059

C. Itoh means excellence in printers

C. Itoh Electronics is part of the 118-year-old C. Itoh & Co. Ltd. world-wide trading organization.

Disc has made it easy for the OEM using optical encoders in small quantities to realize costs in the same low range as the big users—like under \$100.00.

We've maintained the same high order of resolution, accuracy, and reliability found in our more expensive units for this new EC series. "EC," obviously, is our economy model, but it could also stand for exceptional capabilities. Here's what you get for your \$99 (much less in quantity):

- LED source
- 20 to 1024 pulses/revolution
- Differential electronics
- Square wave output
- ± 2.5 minutes accuracy
- Solar cell light sensors
- Instrument bearings
- $\frac{1}{4}$ " shaft for interfacing

Translated into benefits, these features mean the Disc EC ROTASWITCH® Encoder gives you superior performance, a long service life, and a unit cost you just can't touch.

That's the model EC 81. It has a single channel output. If you need dual channel, we also offer the EC 82 at \$125.00 in single quantities. It too plummets to well under \$100.00 in quantity.

A new spec sheet is just off the press—write or call for your copy. Immediate questions can be answered by calling 714/979-5300.

Disc Instruments, Inc., 102 East Baker Street, Costa Mesa, CA 92626.



THE PRICE OF OPTICAL ENCODERS JUST PLUMMETED.



Circle 21 on Reader Inquiry Card

SOFTWARE DESIGN SERIES

mentation is correct and meets their needs. Develop a procedure for grading and improving documentation.

• Maintenance programmers must not only check and upgrade the original documentation, but must fully document any changes that they make.

As system designers implement more functions in software, software documentation grows in importance, and relegating documentation to "the back-burner" will cost you and your company time and aggravation. Since products like those will possess long and useful lifetimes due to their software, field problems will arise; later improvements will be retrofitted. When this happens, those involved at this later date may not be the same individuals who programmed and designed the product. Unfortunately, those who did do the hardware and software design may not be available in the future or, if so, may not readily recall what they did back then (or even provide much advice, as they will be on other projects). Poor documentation will cost far more in time, expense and aggravation in the future than now. Obviously, your designer-programmers will be familiar with what they've just done. But it won't be so apparent two years from now when someone must unravel your software because of inadequate documentation. It is the responsibility of project managers to determine standards for good software documentation and for designers to employ good documentation.

REFERENCES

1. London, K.R., *Documentation Standards*, 2nd Edition, Petrocelli/Charter, New York, 1974.
2. Kernighan, B.W. and P.J. Plauger, *The Element of Programming Style*, McGraw Hill, New York, 1978.
3. Leventhal, L.A., "Structured Programming Formulates Microprocessor Program Logic", *Digital Design*, October 1978, pp. 30-40.

Rate this Article: 1L, 1M, or 1H on Reader Inquiry Card.

SEE THE LEADING LINEUP OF COMPUTER PERIPHERAL

OEM MECHANISMS

PRINTERS ■ DOT MATRIX ■ FULLY FORMED CHARACTERS ■ TAPE PUNCH

These high quality, high profit to OEM mechanisms are backed by the worldwide reputation of EPSON's parent, Shinshu Seiki Co., Ltd., Japan. All mechanisms guarantee long-life construction, competitive OEM pricing and many valuable design innovations.

**MODEL 3110
DOT MATRIX PRINTER MECHANISM
with 80 column format**

Designed for use in small-business and home computers, the long-life, low-cost Model 3110 features a 100,000,000 character dot head, 150 characters per second, with 5X7 dot matrix character.



NEW

CIRCLE 14

**MODEL 512
DOT MATRIX PRINTER MECHANISM
with 40 column format**

This compact printer has the same 100,000,000 character dot head as the Model 3110, with MCBF of 5x10⁶. It prints at a rate of 3 lines per second.

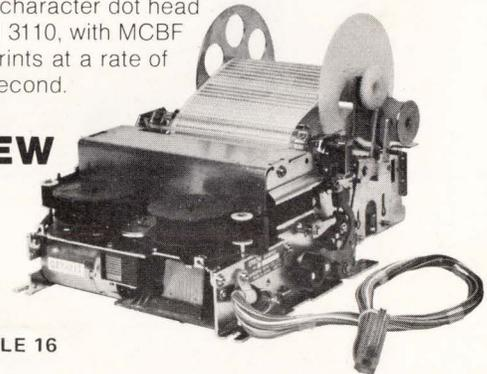

NEW

CIRCLE 16

**MODEL 2610
LINE PRINTER MECHANISM
with fully formed characters**

An EPSON-designed belt-impact printing mechanism gives clear, readable, fully formed characters. Model 2610 prints 150 lines per minute using a 64 character set, 80 column format.

A complete line printer with case, the Model 10, also is available.

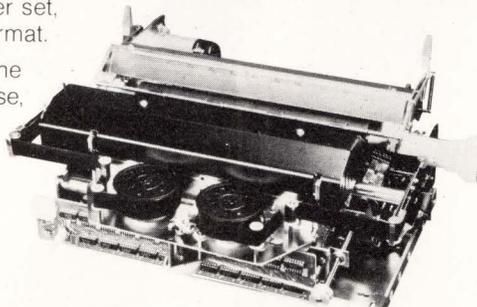

CIRCLE 15

**MODEL 6110
TAPE PUNCH MECHANISM
with full-size operation
in a miniature chassis**

A long-life punchblock that punches 100,000,000 characters with normal paper tape.

Unique brushless motor affords long life, low power operation. Size is only 4" w x 6" d x 4 1/4" h. Operates at 50 characters per second.



CIRCLE 17

write for complete information and OEM prices

EPSON

EPSON AMERICA, INC.

23844 Hawthorne Blvd., Torrance, CA 90505
Telephone (213) 378-2220 · TWX 910 344-7390



↑ TO CHICAGO ↑
NEW DIRECTIONS IN
DATA COMMUNICATIONS
AND DISTRIBUTED
DATA PROCESSING



OVER
70
SESSIONS

OVER
800
EXHIBIT
BOOTHs

**NEW DIRECTIONS
INTERFACE '79**

NEW DIRECTIONS . . .

In DDP -- FUTURE TRENDS
In DDP Management -- ORGANIZING FOR TOMORROW
For the new user -- DATACOMM SCHOOL
For the experienced user -- APPLICATIONS FORUMS
In software -- MERGING THE DATA BASE AND DATACOMM ENVIRONMENTS
In total network services -- ACS, SBS, XTN
In office communications -- THE 'DISTRIBUTED' OFFICE
In terminals -- MORE INTELLIGENCE AT LESS COST
On the international scene -- EXPANDING MULTINATIONAL LINKS
In security -- MAINTAINING DATA AND SYSTEM INTEGRITY
In technology -- MICROS, MEDIA AND MESSAGES

The new directions
that data communications and DDP
are taking today
are pointing the way
to tomorrow's world of processing data.

Plan now
to be well along that road.
Plan to attend
INTERFACE '79.

Plan now to attend INTERFACE '79 . . .
The largest data communications conference and exposition in the world.

 **Data Communications**
INTERFACE '79
The Seventh Annual National Data
Communications Conference and Exposition
Co-Sponsored DATAMATION Magazine

McCormick Place, Chicago
April 9-12, 1979

Conference and Exposition Management
by **THE INTERFACE Group**
160 Speen St., Framingham, MA 01701
Call toll-free (800) 225-4620.
In Massachusetts call (617) 879-4502.

Choosing a Higher Level Language for μ P DEVELOPMENT SYSTEMS

Roger Hokanson,
Logic Development Products Tektronix

Full scale development systems to support microcomputer design have achieved new levels of refinement and versatility. New entries in the field have introduced more user-oriented interfaces and alternatives for multiple access and interactive development team approaches. Also more coverage is available for a large number of microprocessors and single-chip microcomputers. For example, the Tektronix 8001/8002A system now supports the Intel 8080 and 8085A, the Motorola 6800 and 6802, the TI TMS9900, the Zilog Z80, and the Mostek 3870 and 3872. The firm has announced that it will soon support the Intel 8048 family of microcomputers and the RCA 1802, the only 8-bit CMOS microprocessor.

Nevertheless, the leading point of interest, controversy and discussion among microprocessor system designers and users seems mainly to involve higher level languages. Some manufacturers and groups have extended a number of languages developed for mainframe systems for use with microcomputers; they have developed a few others from scratch with microcomputers in mind.

Not surprisingly, manufacturers of microprocessor development systems have begun to offer higher level language compilers and interpreters to aid the software development process. In addition, some independent software houses offer higher level language packages for operation on popular development systems.

A higher level language offers the prospect of a faster development cycle than you can achieve through assembly programming. Since a single HLL statement may represent 20 or

The Spectrum of μ P Languages

A broad range of programming languages have been developed. The range covers the spectrum from the simple, machine-level ZEROs and ONES of binary code to problem-oriented, higher-level languages like microFORTH, Fortran, PL/M, Pascal, Basic and the like. Four categories of levels of languages exist:

- Machine code — These binary, octal or HEX machine languages are in numeric form; and, though directly executable by the microcomputer, are not exactly suitable for designer-programmers, who must painfully hand-code them. Also, errors are hard to spot. Digital Design recommends that you use machine coding in two cases — when your program is small or when there are just a few changes to make in a large program, since a microcomputer development system will not be worth the expense or time.
- Assembly-level languages — Although a step above machine languages, assembly languages are more "Human-oriented: and, with an assembler, produce the exact same program code. Programs written in assembly languages are easier to learn, code and debug than machine language programs.
- High-level (compiler) languages — Working in these programmer-oriented languages is far easier than assembly languages. Very few characteristics of the individual microcomputer are reflected up into the high-level language used, so that the programmer does not see the intricacies of the application. Fortran, Focal, Basic, Pascal, APL, Cobol and the like are a few well-known languages. Since these compiler languages are easy to learn and use, a programmer's daily output is far higher than if he used assembly

continued ►

more assembly statements, coding and debugging is easier and faster. For the growing ranks of design engineers with system responsibilities, software programs that are easy to write are more welcome than ever. Aided by the modular design and flexibility of some HLL versions, a system designer can write, test and debug the logic of a program in a higher language and then use assembly language as a supplement to optimize functions or operations that are frequently used or require long execution times.

In the past, a considerable appetite for memory has hamstrung easy-to-use and quickly-debugged higher

level languages. But the cost of memory has tumbled in recent years. Optimization techniques, developed for resident translators (compilers and interpreters) used to convert English-like HLL inputs into machine-readable object code, now brings program storage requirements more into line with the capabilities of microprocessor systems.

With a growing number of languages to choose from, microprocessor system designers must now more than ever learn what features are significant when selecting a higher level language for a microprocessor development system (or, conversely which development system offers the best

NEW 6-FOOT CABINETS FOR DEC USERS

WESPERLINE WP 973 SIX FOOT CABINET

IMMEDIATE DELIVERY ■ MOST
ADVANCED DESIGN AVAILABLE

■ DEC look-alike design

Designed as an alternate to, or addition to the DEC H960 CA type cabinet, the Wesperline Model WP 973 is almost identical in appearance.

■ "Knock-Down" construction

The WP 973 is designed to be disassembled for shipment as a flat package less than ten inches high.

■ Heavy duty construction

Meets or exceeds competitive units.

■ Standard Features

- AC distribution panel with circuit breaker
- 575 cfm exhaust fan
- Stabilizer feet
- 63" vertical mounting space at front and rear

■ Optional Features

- Custom logo frame panel
- Casters

■ Also available as a four foot cabinet

SEND FOR COMPLETE
INFORMATION

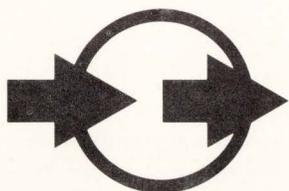

WESPERLINE™

Division of WESPERCORP

1100 Claudina Place, Anaheim, California 92805, U.S.A.
(714) 991-8674 TWX: 910 591-1687 Cable: WESPER

Circle 22 on Reader Inquiry Card

choice of a language). For example, efficient compilers support some high level languages available for microprocessor systems; other languages rely on interpreters to convert commands into machine-readable object codes. Even compilers for the same language can differ from each other and depend on the version offered with the development system.

Language choice

How, then do you choose a language from among the many now available? You can simplify the chore through the essential process of determining your specific needs in advance.

μP Languages continued

code. Also, high-level language is transferable, that is, programs should be easily transferred from one microcomputer to another. This is not always so easy, since, to take one case, a program written in one dialect of Basic isn't directly transferable to another micro without revision. Worse yet, high-level languages are inefficient and so use more memory and take longer to execute. Typically, high-level programs are 15-20% longer than good assembly language equivalents. If the micro application calls for the micro to service numerous interrupts and perform other tasks that won't permit this inefficiency, then the programmer is doomed to coding in assembly language (or at least, in the time-critical portions of the program). Fortunately, in many application, high-level language inefficiencies are acceptable; and with faster micros and the falling cost of memory, this is less of an objection. High-level programs are also easier to document, easier to debug and easier to modify at a future date. Also, the potential efficiencies of compact assembly programming are often lost when relatively inexperienced programmers are used.

- Systems-implementation languages — Although basically compilers, they have assembler-like characteristics to permit programmers to code in high-level languages, yet revert to assembler languages when needed — for example, when portions of the program require faster execution times or less memory (and hence, demand more compact coding).

First, a higher level language may be practical or even impossible to use in a given system. For example, if storage space is limited, the scheduled production run is small, and the design time factor is not critical, assembly coding may provide a better solution.

When making the decision to use an HLL with a development system, designers should pay special attention to vendor documentation of the system's capabilities. It's critical to understand just what the language can and cannot do, what factory support is provided, what are the memory requirements, what optimization features are available, what diagnostics are available, and how error messages are presented. For instance, debugging is much easier if the HLL error messages are presented in explanatory terms rather than in cryptic abbreviations.

Next, you should evaluate the relative advantages and disadvantages of using an interpretive language or a compiler language. In most instances, a compiler performs better in time-critical applications, while an interpreter functions better in operations where interacting or debugging are critical.

Because it retrieves data from memory one line at a time and then transmits it for processing, an interpreter needs an initial memory overhead of about 2K bits. Of course, the process also slows down execution of the final code. On the other hand, a compiler requires none of the memory

overhead associated with the line by line interpretive process, because it executes code directly. As a result of their one-statement-at-a-time conversion of source code into machine language, interpreters generally provide better run-time error diagnostics.

Generally speaking, however, microprocessors are not involved in applications requiring extensive user interaction or program debugging. Except for rare cases, compiler languages seem better suited to microprocessor-based systems.

Modular capabilities

One of the most critical characteristics for an HLL in microprocessor system development is "block structuring" or modular programming — the ability to develop separate sections of code independently of one another. The compiler should provide simple interfacing between written and debugged mod-

ules separately. At the same time, it should allow access to common memory slots with the same or different names. For example, the designer should be able to define the parameters by which an "apple" in one coded module is counted as an "orange" in another module.

Block structuring allows a team of specialists to divide the software development task; each team member works on a separate function or set of functions. Experience at Tektronix has shown that this division of labor is the preferred way for system development.

The ability of the compiler to relocate and link with assembly code is an equally indispensable capability for microprocessor applications. This feature should allow the linking of assembly language sections written for storage or speed optimization easily and efficiently with the higher level language program.

The so-called "80/20 rule" precipitates the linking of sections of assembly code to HLL programs. A sensible rule of thumb allots 80% to processing and 20% to executing the code. To speed up a program, a designer must strive to find that 20% and hand code it in assembly language. Usually, such optimization results in a significant improvement in system performance.

How does a programmer solve the following common condition? Suppose he wants to program a function that the higher level language he is using was not designed to execute. He must use assembly language within the HLL program. For example, in a case at Tektronix one processor stored data in memory with least significant and most significant bits. But, the generated data had to be transmitted to another processor that stored the information in reverse order. This transformation took about 20 separate statements in the language used to swap bits around so that they were in the right order for the second processor. Rewriting that bit-swapping subroutine in assembly language made it possible to derive source code that was much shorter than the original HLL code.

Extensions

Because we originally developed higher level languages for general purpose computers, we must extend them to interface efficiently with microprocessors. Four types of extension are of greatest importance.

First is the ability to handle bytes. The HLL must be able to perform

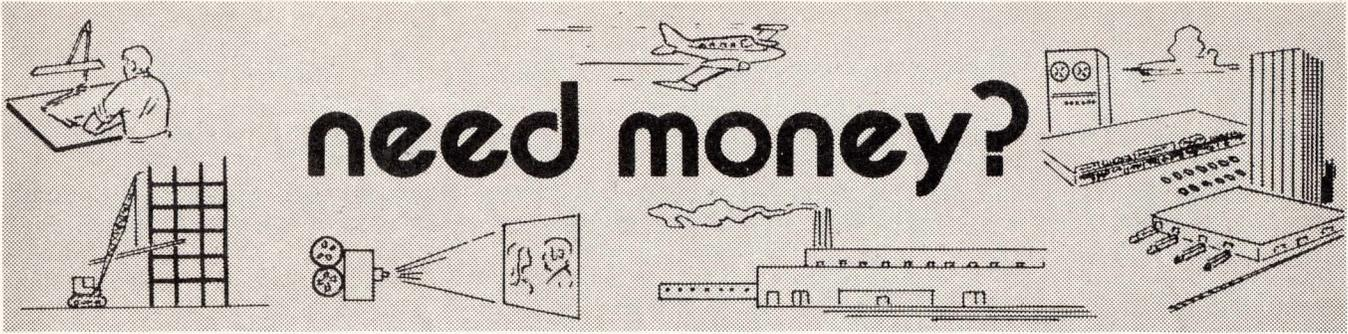

need money?

WHO DOESN'T NEED MONEY?

Ever heard that old cliché? Unfortunately, the people that really need money don't have the money to secure a loan of the type they need, nor do they know where to go to get that much needed financing.

FINDING MONEY — THAT'S OUR BUSINESS

Worldwide Finance Exchange have the sources and we will share them with you for only pennies each. You can finance almost any venture, expand your business, or lease now and purchase later for as little as one dollar, buy that piece of real estate you've had your eye on, or just secure financing for whatever you have in mind, even that new idea you have. Our sources are proven and have the money available now.

LISTED BELOW ARE JUST A FEW MAJOR FIELDS MONEY IS AVAILABLE FOR

REAL ESTATE

NEED CAPITAL FOR FIRST AND SECOND MORTGAGES, SALE LEASE-BACKS, REFINANCING OR JOINT VENTURES AND PARTNERSHIPS?

Names and address of over 200 firms that will loan or invest in: warehouses, apartments, shopping centers, office buildings, recreation facilities, mobile home parks, nursing homes, hospitals and agricultural.

VENTURE CAPITAL

NEED CAPITAL FOR A NEW BUSINESS OR EXPANSION OF YOUR PRESENT BUSINESS IN CONSTRUCTION, TECHNOLOGY, MOVIES, MANUFACTURING, OIL & GAS AND OTHER ENERGY RELATED PROJECTS.

Names and addresses of over 300 firms that will loan or invest in proposed ventures or present businesses, including several that specialize in loans to minorities.

BUSINESS EXPANSION

NEED WORKING CAPITAL FOR EXPANSION OF YOUR PRESENT BUSINESS?

Names and address of over 100 firms that will loan you capital on: equipment, inventories, account receivables, factoring, time sales contracts, and Redis counting.

LEASING

NEED CAPITAL FOR EQUIPMENT, MACHINERY, OFFICE FURNITURE, COMPUTERS?

Names and addresses of 400 firms that will buy your equipment for you and lease it to you with the option to buy for as little as one dollar at the end of lease term.

HELPING YOU SECURE FINANCING IS OUR BUSINESS TOO.

We'll share our sources with you for less than 5¢ each. Not only will we give you their names, addresses and telephone numbers; we'll include the person to contact. We will even introduce you personally if you need it. All you have to do is fill in the coupon below and mail it today, we'll do the rest. Hurry! Our lenders already have over 50 billion dollars on their books.

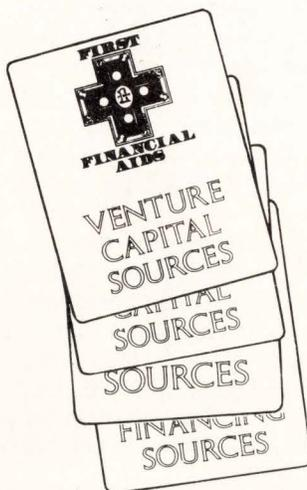

Worldwide Finance Exchange
Box 2952
Tulsa, Oklahoma 74101

CLIP AND MAIL TODAY

No 1035

Please send the lists I have indicated:

- Leasing — \$25.00 Venture Capital — \$25.00 Business expansion — \$25.00
 Real Estate — \$25.00 Any 2 — \$40.00 Any 3 — \$52.00 All 4 — \$60.00

Enclosed cash, check or money order to cover above, or charge to my Visa Master-Charge

Account No. _____ Expiration date _____

Interbank No. _____ (Master-Charge only)

Name _____

Address _____

City _____ State _____ Zip code _____

Circle 23 on Reader Inquiry Card

such tasks as taking individual bits and shifting them from right to left, and making parity comparisons.

Hand in hand with this capability is the ability to handle such microprocessor logical operations as AND, OR, NAND and NOR. Standard operations, such as comparing zeroes and ones for exclusive ORs through two bytes, are endemic to how a microprocessor functions and, since such operations do not exist in the original versions of HLLs languages, we must provide for them through extensions. These kinds of differences also mandate the ability to get at the I/O ports and memory addresses of the microprocessor directly by using variables rather than I/O statements. For example, when using Tektronix 8002 MDL BASIC, you can address the hardware directly through the language, such as specifying I/O ports or memory addresses for variables in the program. Simple LET commands in conjunction with the specified variables can move data into or out of a hardware location without the need to go to assembly language programming, as often required by BASIC systems.

Another important extension is the ability to accept and deal with interrupts in real time through the HLL. This characteristic is known as interrupt handling. A subset of this ability uses re-entrant code to return to an interrupted procedure. Since the primary use of microprocessors is for control applications, interrupts are more than likely to be an important system capability. For that reason, a user usually wants a compiler that can automatically register values at the time of an interruption onto what is known as a "stack", from which they are retrieved as the operation resumes.

Finally, it is preferred that the language use integer (no decimal point) arithmetic, rather than floating point (decimal point) variables. Number-crunching or computation-oriented applications, for which microprocessors are not well suited, typically use floating point arithmetic. System designers who need floating point, however, can find it available in some of the other languages.

Optimizing techniques

Many optimizing techniques which compilers use improve execution and memory efficiency. As the technology advances, the number of options is bound to multiply. However, for the time being, a prospective ought to look at four basic techniques. Of the

four, three are especially concerned with minimizing redundancy — compile time arithmetic, common subexpression elimination and constant subscript resolution.

Compile time arithmetic is an optimizing technique in which operations involving constants are evaluated and a net value introduced in the program at the time of compilation, rather than having the same operations executed again and again during execution of the final program. For example, reducing $A=3+4+5$ to $A=12$ reduces memory requirements and shortens execution time.

Before You Buy . . .

When shopping for a microcomputer development system, there are certain things to keep in mind. Here are several points to keep in mind:

- Determine your needs
- What μ Ps must it support?
- What high-level languages must it support?
- In-circuit emulation
- RAM storage space
- Logic analyzer functions
- Mass storage (size and speed)
- Speed
- Loads into PROM programmer
- PROM/EPROM types supported
- Emulate I/O devices
- I/O-peripheral interfacing
- Bus structure compatibility
- Breakpoint/interrupts
- Support software
- Cost (optional prices)
- Leasing vs purchase

Common subexpression elimination, like compile time arithmetic, is used to make a one-time-only evaluation of a subexpression, such as a parenthetical notation, that occurs more than once in a program. The resultant value is then inserted in all places where the subexpression occurs. During execution, the program operates with the redundant value rather than executing the subexpression again and again.

Similarly, constant subscript resolution refers to the insertion of the memory value represented by a subscripted variable if and when that subscript is a constant. During execution, the value is used rather than performing a look-up operation in the variable array.

Finally, peephole optimizing is the MDS equivalent of "global optimiz-

ing", the common "crunch-down" technique used in software development for large mainframe systems. Since it's generally impractical to crunch a whole program in microprocessor development systems, peephole optimizing allows for clean-up of small sections of code; it replaces the original with more efficient code whenever possible without altering the execution function.

The choice of languages

For the microprocessor system designer who wants to go the higher level route, possibilities include various versions of Pascal, BASIC, PL/M (from Intel), FORTRAN and COBOL. Less common are Focal, FORTH, "C" (from Bell Telephone Laboratories), MPL (from Motorola) and P1 μ S (from Signetics). Other languages, including specialized "cult" HLLs, are becoming increasingly available for various microprocessor applications, though their capabilities have only begun to be tested.

A recent survey indicated that higher level languages are acceptable to most of today's microcomputers. In fact, only 15% of the operating systems are limited to assembly language. BASIC, by far the most common HLL, is accepted by about 45% of those microcomputers able to handle a higher level language. FORTRAN, COBOL and Pascal are becoming increasingly available as options on new systems.

Most observers concede that BASIC, already familiar to most programmers and often adapted to microprocessor-based systems, will continue to be one of the most commonly used HLLs. In the past, BASIC has performed best as an interpreter for the kind of small, single task programs that a system designer sits down and types out. But recently, the language has been adapted for compiling applications. At least one new version, Tektronix 8002 MDL BASIC, contains modular construct and hardware linkage capabilities. Some BASIC interpreters also allow calling of assembly routines, and the language can provide linking, if it is instructed to reserve memory space when first loaded. Typically, BASIC does not handle interrupts and therefore is not ordinarily used for interrupt coding. However, the Tektronix version includes USES and PROVIDES commands that allow programmers to specify procedures to be called when an interrupt occurs.

Many predict an increased use of Pascal-based languages in the future.

CRT COPIER for 2640's

The new Model 8640
CRT copier provides hard
copies from HP 2640
Series terminals

in less than 10 seconds

The Houston Instrument 8640 CRT copier, at \$4495, provides you with permanent high quality hard copies from any HP 2640 Series terminal equipped with HP's video interface. Utilizing HI's electrostatic technologies, the Model 8640 produces permanent non-fading copies at about one third of the cost of comparable dry silver copies. The Model 8640 is the choice hard copy adjunct to your terminal.

- No warm up time
- Proven electrostatic printing technique for high contrast output and no fading
- Low operating noise
- Inherent high copying speed capability
- Provides copies from up to four terminals (with Model 8640A)
- Price for Model 8640 \$4495* (Model 8640A \$4995*)

**houston
instrument**

DIVISION OF BAUSCH & LOMB

ONE HOUSTON SQUARE
(512) 837-2820

AUSTIN, TEXAS 78753
TWX 910-874-2022

EUROPEAN HEADQUARTERS

Rochesterlaan 6 8240 Gistel Belgium
Phone 059/277445 Telex Bausch 81399

"the graphics - recorder company"



*U.S. Domestic Price only

**"Also send for information on our
Tektronix 4010 Series terminals"**

Visit us at the
Pittsburgh Conference booths 217 & 219

For rush literature requests or local sales office information only, persons outside Texas call toll free 1-800-531-5205

Circle 24 on Reader Inquiry Card

If you make top-quality data terminals, here are four reasons to use Setchell Carlson CRT data displays in your system.



Reliability

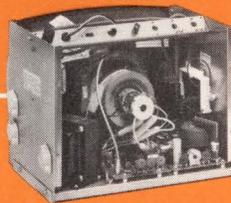

Experience

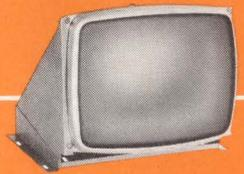

Delivery

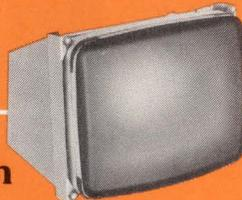

Cooperation

Our data displays are outstanding solid-state designs with critically matched magnetics to optimize the performance levels and dependability demanded by your customers. We use the most advanced engineering and production techniques to assure consistency of performance. No data display is built with more deliberate attention to quality and reliability.

We have been in the electronic display business long enough to know about rush orders. If you need it yesterday — we'll try to get it to you yesterday.

We've built thousands of displays for many of the major manufacturers in the country. Perhaps we already have a unit that would meet your requirements. With

slight modifications. It would be less costly than starting from scratch. If you need a new, special package — we'll produce it for you, in the configuration you want, at minimal expense.

If you're developing a new data terminal, we will be glad to cooperate with your terminal design engineers in reviewing your exact specifications and developing the most economical display possible. And quickly! Whatever you need, we have the experience and talent to design it. And improve it.

But don't take our word. See for yourself by contacting us today.

You'll come up with your own reasons for using Setchell Carlson CRT data displays.

AUDIOTRONICS
VIDEO DISPLAY DIVISION

530 FIFTH AVENUE N.W. NEW BRIGHTON, MN. 55112 • (612) 633-3131

Because the Swiss import incorporates a variety of structuring methods for data, especially programmer-definable types, this major innovation makes it ideally suited for microprocessor-development systems. Newer versions also offer the flexibility of modular design. The interpreter version of Pascal has enjoyed wider use than the late-arriving compiled Pascal, but suffers from the disadvantage of not allowing assembly language calls and requiring 48K of memory. However, compiled Pascal can be linked with assembly language routines with minor language extensions. Unlike the original, newer versions of standard Pascal are being designed to support interrupts.

Computation-oriented languages such as FORTRAN and COBOL, whose inherent limitations have previously limited their usefulness in microprocessor applications, have only recently been resurrected in more compatible forms. It's too early to tell how they'll perform, though long-standing usage and built-in modularity in its original form provides FORTRAN with an important advantage.

Although "C" is basically a structured language, it is not as highly structured as Pascal, which is very restricted in what it can do with a given variable. Bell Labs designed "C" for writing operating programs for users who do not ordinarily wish to write in assembly code. Several versions have recently been developed for microprocessor use, including at least one designed to run on the Intel 8080.

FORTH, or microFORTH, is a very flexible language that allows you to define your own commands in terms of basic operations. This capability has made it popular for process control applications, though much less workable for applications involving complex mathematical functions. A concise but cryptic language, it is a stack-oriented, interpretive HLL that has been modified to run on many microprocessors. Some versions supply their own assembler for machine language function definitions.

Just a few of the major higher level languages are now available for use in MDS design. Literally hundreds of minor dialects are currently clamoring for attention, as the use of HLLs becomes more and more attractive. In all probability, the more esoteric of these will not gain popular acceptance and selection will become simpler. □□

Rate this article: 2L, 2M or 2H on Reader Inquiry Card.

Circle 25 on Reader Inquiry Card

Double Density Floppies for your LSI-11/2

The FD-211 Dual Floppy System is the perfect plug replacement for your RX02 . . . In half the space . . . and at up to 30% savings.



- 5¼" Low Profile Chassis
- Dual Shugart Drives
- 512K Bytes Per Drive
- Front Panel Write Protect Switches
- Photocell Write Protect
- Complete Instruction Manual

CRDS continues its spectacular performance in the field of Peripheral Controller Design. Designing control/interface electronics onto a single Dual Height Card and with:

- Single and Double-Density Operation
- Complete Instruction Set Compatibility with RX02
- Integral Bootstrap Loader
- Built-In Self Diagnostic, Formatter
- Dual Height Controller for LSI-11 or LSI-11/2 Backplane

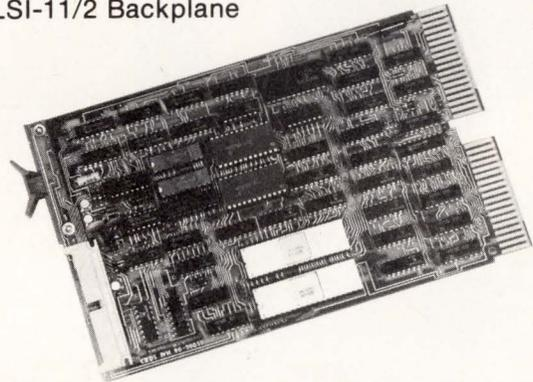

Our MF-211 Dual Floppy/LSI-11 System does everything the PDP-11 V03-L will do . . . for a lot less.

Check These Features:

- Single and Double-Density Operation
- Complete RX02 Instruction Set Compatibility
- Over One Megabyte Storage Per System
- Functionally identical to the DEC PDP-11V03-L
- 10½" Rack Mountable Enclosure
- Available with DEC Software and Interface Cards
- 30K Addressable Memory
- Considerable Dollar Savings

Our MF-211 Dual Floppy/LSI-11/2 System, using the CRDS Double-Density Controller is functionally identical to the DEC PDP-11V03-L, however using only 10½" rack space. The MF-211 is the perfect low-cost answer to your PDP-11V03-L requirement.



For more info on our FD-211 and MF-211 Double-Density Floppy Disk Systems, just call or write:

Charles River Data Systems, Inc.,

4 Tech Circle, Natick, Massachusetts 01760 Tel. 617 655-1800



Circle 26 on Reader Inquiry Card



Ramtek's 6110 Colorgraphics features a 320 by 240 by 3 graphics display matrix, a 80 by 24 alphanumeric format, and has a 13" medium resolution color monitor.



Conrac Data Products' 6800-based 480/25 is fully buffered, stores and displays up to 25 80-character lines, and is modular and fully programmable.

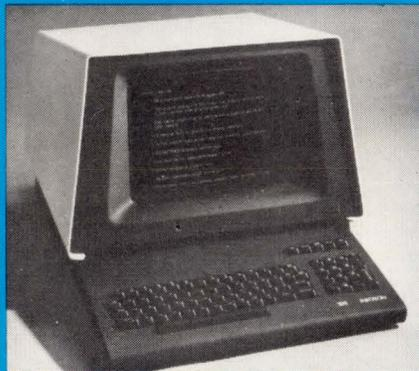

Infoton's I-100, Z-80-based display terminal features special PROMs that allow it to emulate the control code sets of other independent vendor terminals.



Microterm II is packaged into an integrated desktop cabinet measuring 13 3/4" high, weighs less than 50 lbs.

SELECTIN

Characteristics need

Ted Ellison, *Reality Program Manager and*
Tom Hadley, *Director, Software Engineering*
Microdata Corporation

Matching a terminal to a computer is a relatively complicated task. Careful consideration should be given to defining terminal and system characteristics so that they will be properly matched.

Terminals come with a wide range of functions — many of little or no value unless the system is designed to use them. As the system becomes more clearly defined, terminal selection becomes a simple job of choosing the terminal(s) which most closely provide required system functions.

Choosing terminals becomes more complicated if more than one type is required. While many terminals perform the same functions, the implementation of a specific function varies from terminal to terminal. The standard backspace character is an ASCII 8. A quick check of terminal specs calls attention to the fact that terminal manufacturers have many characters or character sequences to physically move the cursor back one space. This type of incompatibility (repeated with many functions) increases the system software task and greatly reduces the compatibility of programs between terminals.

The more types of terminals present on the system, the more compromises required for implementation. The most common recommendation in this situation is to group the terminal types where possible. Additionally, terminals chosen should be selected from a single manufacturer who can provide commonality in a "family" of terminals.

Considerations in selection

1. Maintainability and reliability should rank high on the list when purchasing terminals. (Depending on the system size and configuration, termi-

nals can represent a large portion of the initial system cost plus the ongoing maintenance charges.)

2. Check out the Mean Time Between Failure (MTBF) and Mean Time Between Repair (MTBR) of the selected terminals.

3. Don't forget the monthly maintenance fee. (Terminals used to maintain data can prove very costly if they are not operational for extended periods.)

4. In the case of a point-of-sale (POS) device, it requires "fallback" to manual operation while awaiting repair. (Be certain provisions are made in the system to handle manual operation if required.)

5. Many systems require terminals be placed in remote locations. Determine if the selected vendor offers service in that area. (There may be an additional charge.)

6. Many terminals contain self-diagnostics used to troubleshoot problems. Many times diagnostics are activated automatically when the terminal is powered on. Some can be activated by the operator and some remotely activated by the host computer. In general, these diagnostics locate problems to a "replaceable module" level, thereby improving the Mean Time To Repair (MTTR).

7. Reliability should be investigated from the standpoint of the expected terminal environment. A terminal reliable in an office environment may not withstand temperature ranges on the factory floor. Some terminals are manufactured without cooling fans to reduce the noise level in a controlled temperature environment. The noise reduction can be a nice feature but not at the expense of reliability.

8. Human engineering is an important factor when choosing a terminal. Ter-

G A CRT?

and careful matching

minals are the most common direct human interface with today's computer systems. In fact, many operators feel that the terminal is the computer! A terminal that has a "fuzzy" character display, or a keyboard that "just isn't comfortable" will make acceptance of the computer system difficult.

9. Legible, easily distinguished characters are very important. When considering upper and lower case terminals, notice how much more pleasant the words appear if the lower case characters with tails (descenders) extend below the line. If the terminals selected is a printing terminal, consider the position of the print mechanism when idle. It is very annoying if the most recent characters are obscured. CRT type terminals use a cursor to indicate the current entry position on the screen. An underscore type cursor may conflict with other characters and is not as easily located as the box type.

10. Check for a non-glare screen; glare is very annoying. Consider screen angle with regard to the terminal use — up on a high counter, on a desk. Perhaps an adjustable viewing angle and swivel arrangement are in order.

11. The keyboard must be comfortable. Operators like to be positioned at various angles to keyboards. If they can't move the keyboard — the entire terminal must be moved. In most applications, it is important for the alpha character set to be "typewriter compatible." Perhaps special function keys should be color coded or lighted; and certainly any special keys which could be catastrophic to the system should be remote from high usage keys, and require a two-hand operation.

12. All necessary controls and switches normally used by the operator should be within easy reach from a normal operating position. These controls in-

clude brightness and contrast knobs, local/remote switch, volume, baud rate and on/off switches.

13. If there is a portability requirement, then the terminal weight should be reasonable. Also, ensure that auxiliary pieces of equipment like movable keyboards or external power supplies are easily disconnected.

Functional requirements

While evaluating functional requirements, remember that many features are interdependent, and many features are useless without associated software capabilities.

Terminals range from dumb to intelligent. Many basic features are common throughout the range and differ only in actual implementation. Some of these are: • standard Asynchronous Communication port (RS-232C), • upper case typewriter-like keyboard, • switch selectable baud rates, • full or half duplex operation and • CRT terminals usually have cursor positioning capability.

As the terminal becomes more intelligent, and cost begins to increase, supplemental features appear: • external printer port, • video port (CRT), • addition keyboard keys (like a ten-key pad), • CRT terminals enhance screen features to include dual intensity characters, tab, protected fields, reverse video field, blinking field and cursor, • multiple character sets, • local memory (multiple pages), • Floppy disc or cassette ports and • real time clock. Other supplemental features include: high level languages (like BASIC or APL), • communication capabilities (synchronous protocols), • field and line editing inserting, delete) • μ P based, • data audit capabilities (e.g. test for numeric data) and • user-programmable function keys.

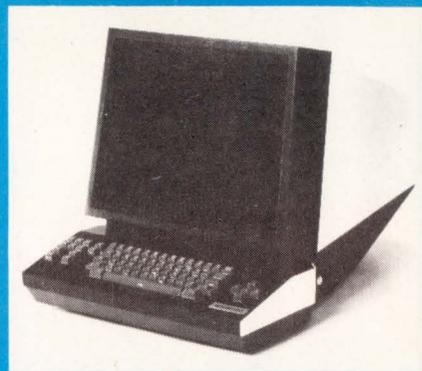

Docuprint's Docuprint 5030 Display Terminal is a "smart" terminal which features a full-page display and sophisticated text manipulation functions.

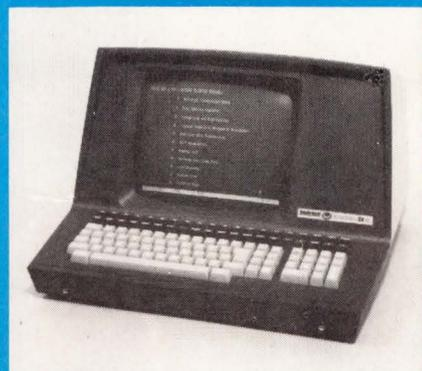

Beehive International's Micro Bee 2 is an 8085A microprocessor controlled buffered video display terminal offering advances in technology and human engineering.

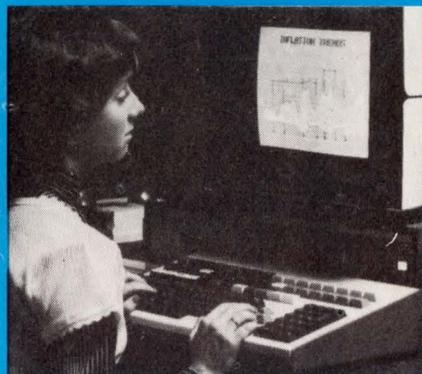

Chromatics, Inc. offers a line of 13", 15" and 19" color screen sizes with Z-80 full memory and I/O structure in a choice of 512 x 256 and 512 x 512 resolution.

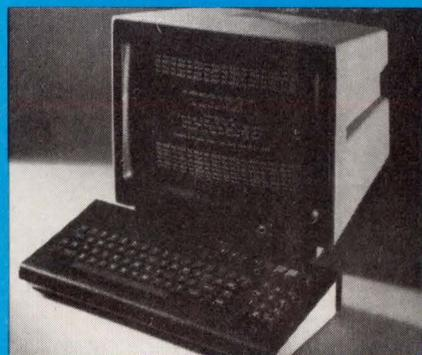

Ann Arbor Terminal Model VT52-COM-PAT emulates the code structure and functions of DEC's VT52.



Latest in the evolution of Vector General's 3000 Series displays, the 3300 Series High-Speed Interactive Graphics Displays operate as peripherals to any mini having standard parallel I/O capability.



The DELTA 7300 16-bit μ C terminal from Delta Data Systems Corp. is a text processing terminal designed for distributed processing applications where large amounts of text must be handled.

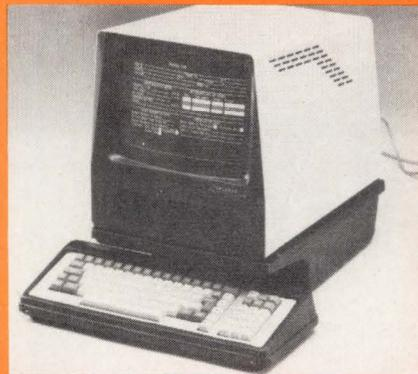

The Teleray 1061 offers programmable I/O speeds, programmable peripheral speeds and enable/disable.

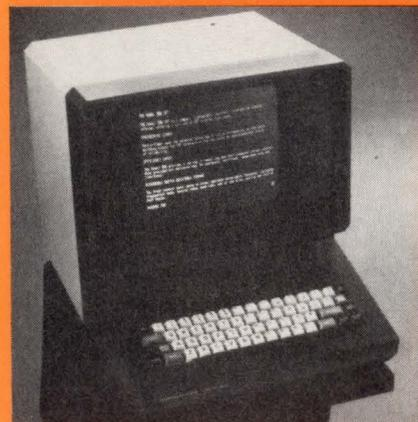

The Model 550 Bantam, a custom-designed LSI chip, combining both μ P and CRT controller, is at the heart of the Bantam CRT from the Perkin-Elmer Corp's Terminals Div. At \$599, (qty 100), the 4th-generation Bantam is a low-cost, full-function CRT.

Then, of course, the more exotic and specialized terminals have features like voice response, light pen input and optical character recognition (OCR) and other special document readers.

Programmability

The most rapidly changing capability today is terminal programmability. The terminal is programmable if the user can use terminal features through a locally stored and executed program. The program may be developed locally from the terminal or remotely at the host computer. Remote programming requires a terminal capable of "downloading" (receiving) the program from the counter.

The price of μ Ps is falling very rapidly resulting in increased power for the terminal at a relatively low cost. In addition, special PROMs are available for implementing high-level languages like BASIC in the terminal.

Programmable terminals can offer increased performance to the overall operating system. For example, high-volume data entry is a requirement of many systems. The system could operate more efficiently (perhaps support more users) if the terminal performed data validation. In this manner, the

operating system need only be interrupted by the terminal to receive "already checked" data.

Programmable terminals perform a variety of tasks. At one moment the terminal may be a data entry station and at the next, be downloaded to function as a HASP workstation or synchronous communication port to another computer.

Remote terminal operation can be painfully slow to the operator, especially if voice-grade lines are used and the transmission rate is low (300 baud). Installing an intelligent terminal at the remote site could buffer the operator from the slow line speed, thus improving actual (and operator's perception of) data being processed.

Look before you leap

Before choosing a terminal for installation on a system, develop an in-depth knowledge of the systems' requirements. Remember that many features are interrelated and often require some host system software to be useful.

Also, it might be a good idea to build a decision matrix listing features the system requires. Weigh each feature and score the available terminals before deciding.

SMART EDITING CRT Usability vs. Sophistication

Staff Report
EECO, Santa Ana, CA

You'll recognize the right kind of intelligent editing CRT for your application by three characteristics: full editing capabilities, formatted data entry and enough programmability to create formats and define operational parameters at the terminal. Once you've found the right category, look more closely at some other critical considerations. Depending upon your applications, the CRT operator will be more or less sophisticated — probably less. So you evaluate your various CRT choices in terms of *usability* — that is, what kind of operational functions are provided? And then, from your own systems point of view, what kinds

of interface/communications capabilities and options are offered?

To make your job easier, here are key criteria to apply to choosing a smart editing CRT:

Physical Configuration

- Full ASCII Keyboard — for compatibility with almost all types of data processing systems.
- Separate Numeric Cluster — for rapid entry of numeric data.
- Programmable Function Keys — for significant impact on operator efficiency by offering single-key selection of commonly-used functions.
- Detachable Keyboard — for optimum flexibility in workstation layout.

NEW!

Another TEC First



Model 70C Microprocessor Based
Card Reader CRT Terminal

- Magnetic stripe card reader keyboard.
- Reads cards encoded to the international air transport association (IATA) standard.
- Up to 76 alpha/numeric characters may be recorded on one card.
- ASCII data is read from the card and sent to the CPU, and is stored in the terminal's memory but not displayed to provide security.
- Offers ability to control access to computer and data files by requiring each operator to have a card, possibly containing a user identification number and security level code.
- Read error light signals operator to reread card in the event of a card misread.
- Applications include credit card sales transactions, airline ticketing, security.

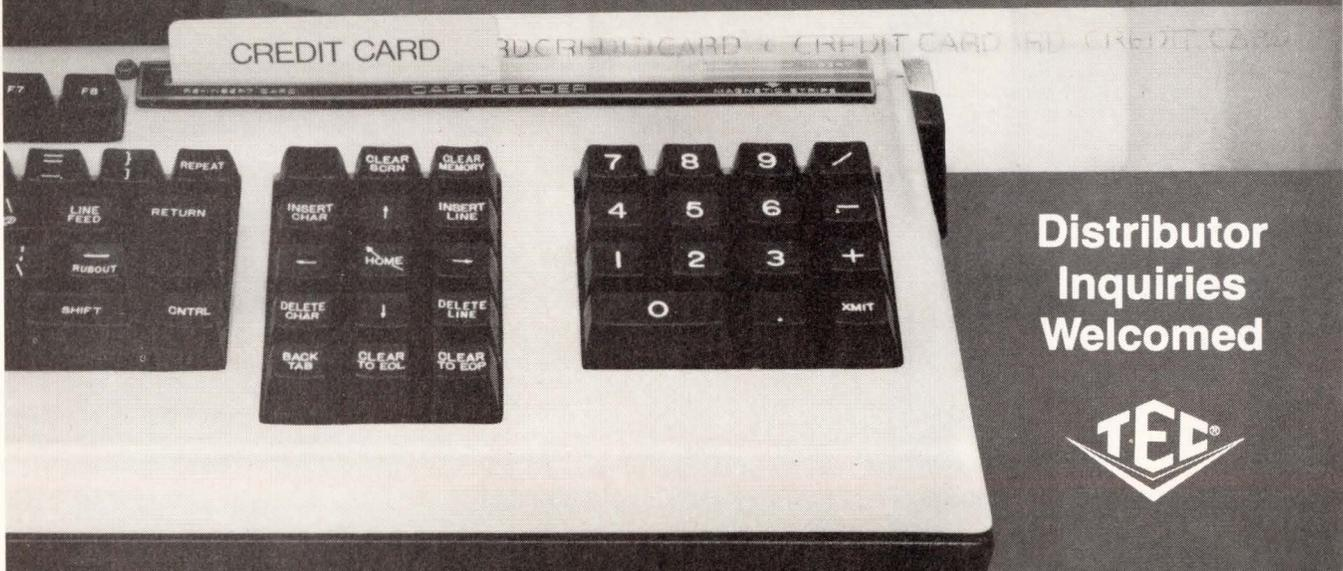

**Distributor
Inquiries
Welcomed**



TEC, Incorporated

Corporate Headquarters: 2727 N. Fairview Ave. • Tucson, Arizona USA 85705 • (602) 792-2230 • TWX 910-952-1377

Eastern Regional Sales Office: 333 Sylvan Ave. • Englewood Cliffs, N.J. USA 07632 • (201) 871-0244

Western Regional Sales Office: 7839 Churchill Way • Suite 133 LB67 • Dallas, TX USA 75251 • (214) 386-4366

TEC International, Inc.

European Sales Office: Avenue Louise 146-Box 6 • 1050 Brussels, Belgium • (02) 649-8154 • TLX. 846-63553

Circle 27 on Reader Inquiry Card



The Datapoint 3600 video display terminal, used in a wide variety of Datapoint's Data-share Business Timesharing Systems, has a factory-option detachable keyboard.



Data 100's new family of multifunction Remote Information Systems allow users to perform batch communications, data entry, IBM 3270-compatible on-line file inquiry, stand-alone processing and file management activities at sites remote from the host computer.

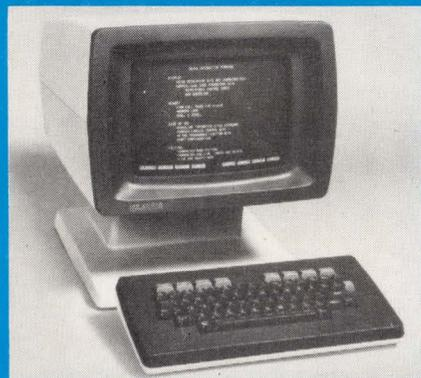

Designed to ease sessions at the terminal, the Hewlett-Packard 2621 offers users a 6" x 8 1/2" high-resolution screen that displays sharp upper and lower case and control characters.



The Series 500 Data-Screen Terminal from TEC is suited to virtually any display terminal application. Switch selectable interface features allow the Series 500 Data-Screen Terminal to work with most popular computers.

- And a nice EXTRA (not essential, but highly desirable): stepped keyboard — for increasing operator accuracy and reducing fatigue.

Operational Functions

- Cursor Wraparound — again, for efficiency.
- Blinking/Nonblinking Cursor — it's nice to have a choice; sometimes blinking can be highly irritating, and sometimes it's required for highly complex formats.
- Paging — extra pages of memory may be required for longer formats and complex applications.
- Screen Display Mode Indicators — very convenient for the operator to be able to see at a glance what mode or modes are currently operable.
- Data Transmission Segments — for maximum flexibility, these should include character, field, line, page; sometimes manufacturers substitute "message" for the two of the first three.
- Request to Send Header — very important for host CPU's which are "busy" and require an interrupt signal from the terminal before transmission.
- Transmission of Unprotected Data Only — for minimizing the transmission of unnecessary information, such as data formats.
- Send All Data — for when the entire form should be sent, as is the case when the form has been created at the terminal by the operator
- Absolute Cursor Addressing — the computer should be able to direct the CRT's cursor to any given set of screen coordinates.
- Host Read of Cursor Position — also, the computer should be able to read the coordinates of the cursor's position at any time.
- Segmented Mode — the computer should be able to split the data on the CRT's screen, transmitting some portions and not others.
- Number of Other Remote Operations — ideally, the remote host can do anything that the operator can do at the keyboard; the number of remote operations will indicate the amount of versatility here.
- Program Mode (with all control codes displayable) — extremely valuable for checking out, monitoring and trouble-shooting formats.
- And a couple of EXTRAS: Local Attribute Programming — to allow the operator to bring up certain functions at the terminal locally and off-line; and Self-Diagnostics — so that the terminal will automatically check itself out, usually at power up.

Video Presentations

Dual Intensity, Blink Field, Reverse Video, Security/Blank Field, and Blank Screen with Simultaneous Operation of all of these — These capabilities contribute to the legibility of formats as presented on the CRT's screen, enabling the system designer to emphasize and highlight particular fields in each format to assure complete and accurate data entry by the operator. Security/Blank Field is particularly important, since it allows the operator to write in a field without the data being displayed.

Data Entry Parameters

Protected Format, Tab (to next unprotected field), Back Tab (to last previous unprotected Field), Tab Set/Clear Key (for setting/clearing tabs at the terminal keyboard) and Line Drawing Capabilities — this group of capabilities are needed for creating data entry formats; with the full set, you can usually duplicate the look of the source document to facilitate transferring data from document into the system.

And a couple of EXTRAS: Alpha Only and Numeric Only Fields — to add data checking capabilities; and Right Justify — particularly handy for automatically aligning columns of figures.

Editing Capabilities

- Insert Character String, Insert Line, Delete Character, Delete Line, Erase to End of Line, and Erase to End of Page — the more of these capabilities your CRT provides, the more efficient will be your operators' performance.
- Clear Screen for Trailing Blank Suppression — extremely important for optimizing throughput; the terminal should only transmit that part of a line in which data has been written — otherwise, most of the transmission will consist of useless blanks (spaces).
- Clear Protected/Unprotected Data — the operator should be able, with equal facility, to clear only the unprotected data and leave the format intact, or to clear the entire screen of all data.
- Remote Editing Capabilities — as stated earlier, the ideal situation is to be able to do anything at the computer end that the operator can do at the keyboard.

Interface Characteristics

- Serial Printer Port/Auxiliary Port — often the latter can be used for the former function, but if you need both, you may find that some terminals offer either/or, but not both.



Finally! A display that won't go out of focus when you turn up the brightness!

It sounds fantastic! And, it is!

Using our new, state-of-the-art Laminarflo® electron-gun CRT's, your computer terminal display is guaranteed not to "bloom" at high-brightness levels.

Why? Because the Laminarflo's high-density electron beam can provide increased brightness up to double your present peak-line brightness — without producing a corresponding reduction in resolution!

In fact, our tubes have operated in high resolution CRT terminals at 60 Ft.-Lamberts without blooming. This means the information displayed on your screen can

be easily viewed, even in direct sunlight!

Laminarflo CRT's are direct replacements for the traditional crossover-gun CRT's your present displays are probably using. So, no special or unusual voltages are required.

And, they're available in sizes up to 25-inch rectangular.

So, if you're tired of squinting at dim displays, give us a call.

Contact the Watkins-Johnson Field Sales Office in your area or phone CRT Applications Engineering in Santa Cruz, Calif. at (408) 438-2100, ext. 308.

Our CRT's are a real sight for sore eyes!

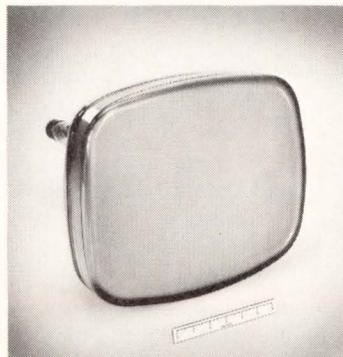

A crisper, well-defined, brighter display with W-J Laminarflo CRT's.



Watkins-Johnson—U.S.A.: 3333 Hillview Ave., Palo Alto, CA 94304 • (415) 493-4141 • TWX: 910-373-1253 • Telex: 34-8415 • Cable: WJPLA • 700 Quince Orchard Rd., Gaithersburg, MD 20760 • (301) 948-7550 • TWX: 710-828-0546 • Telex: 89-8402 • Cable: WJCEI • **United Kingdom:** Shirley Ave., Windsor, Berkshire SL4 5JU. England • Tel: Windsor 69241 • Cable: WJUKW-WINDSOR • Telex: 847578 • **West Germany:** Muenchenerstr. 17, 8033 Planegg • Tel: (089) 859-9441 • Cable: WJDBM-Muenchen • Telex: 529401 • **Italy:** Piazza G. Marconi, 25 00144 Roma-EUR • Tel: 59 45 54 • Cable: WJROM-ROMA • Telex: 60117

Circle 28 on Reader Inquiry Card



Evans & Sutherland Computer Corp.'s refresh interactive 3-D computer graphics system reduces the cost/work station in many application areas, particularly CAD.



Ontel Corp.'s OP-1/R intelligent terminal will run standard OP-1 programs, including programs written in Ontel's high level languages, utilities and commo packages.

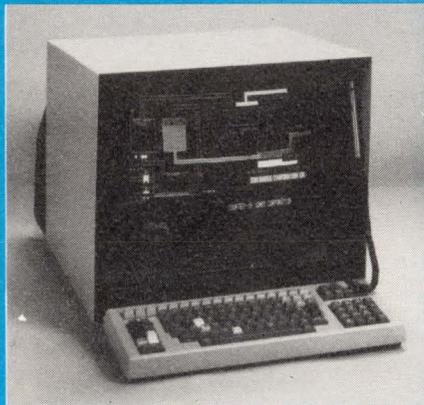

ISC's 8001G has optional light pen and expanded keyboard with 16-function keys.

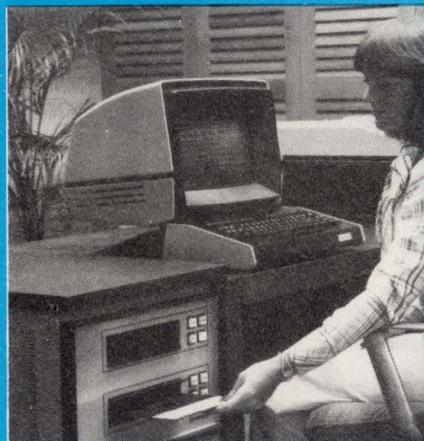

Racal-Milgo's System 4000 Clustered Terminal.

- RS232C/Current Loop — the main I/O is almost always RS232C, but the 20 ma Current Loop for local communications is often optional.
- Number and Range of Data Rates — as long as you get the one you need.
- Polling — almost always an option; various types of protocol are supported.
- And an almost-essential EXTRA: Remote Diagnostics — for troubleshooting from the computer end.

Pricing

Ultimately, of course, price/performance is the most important consideration. You should be able to get nearly all of these features for about \$1500 or \$1600 Quantity 1 OEM Price, and as low as \$1200 or \$1300 in quantities above 25. Beware of the cost-extra options — if some of the essentials are extra cost, it may add considerably to the unit price. DD

Selection Criteria

1. What key points should engineers look for before specifying terminals?

- Analyze application needs in terms of current needs and growth expectations
- Define terminal criteria based on above: speeds, line protocol, electrical interface, intelligence levels, operating environment, flexibility, software/hardware system support needed, etc.
- Evaluate potential suppliers: product cost/price performance comparison, reputation (quality/warranty), human factors design considerations, maintainability, product service capability/price, delivery, cost of consumables, lease/purchase options

2. What problems currently plague CRT display and printer terminals?

CRT

- Tube too bulky
- Limited display size
- Lacks human factors design considerations
- Special Environments
- Difficulty pinpointing failure problems
- Cost Control

PRINTER

- Noise Level
- Reliability
- Size & weight
- Paper handling
- Lack of human factors design considerations
- Print widths
- Multiple copy
- Print density & clarity
- Cost control

3. What CRT and printer terminals advantages exist?

Extensive human factors design including:

Tactile and audible feedback

Sculptured keytops stepped for minimum finger extension and comfort

Large 9 x 14 display font with generous spacing between lines and characters

Font especially designed for easy differentiation of similar appearing characters

A specially darkened and etched glass that diffuses surface reflections and increases contrast

Tube tilt feature allows operator adjustment for ambient lighting condition

Audible & visible alarms & controls for instantaneous operator feedback

Modular design to simplify maintenance

Built-in diagnostics to pinpoint problems

Extremely attractive cost/performance ratio

Inexpensive consumables (uses ordinary paper)

Full character impact printing

Extensive forms handling capabilities

Downloadable display font and program

Extremely quiet display (no-fan)

Compact, light weight display easily relocated by operator

Rubber non-skid display base

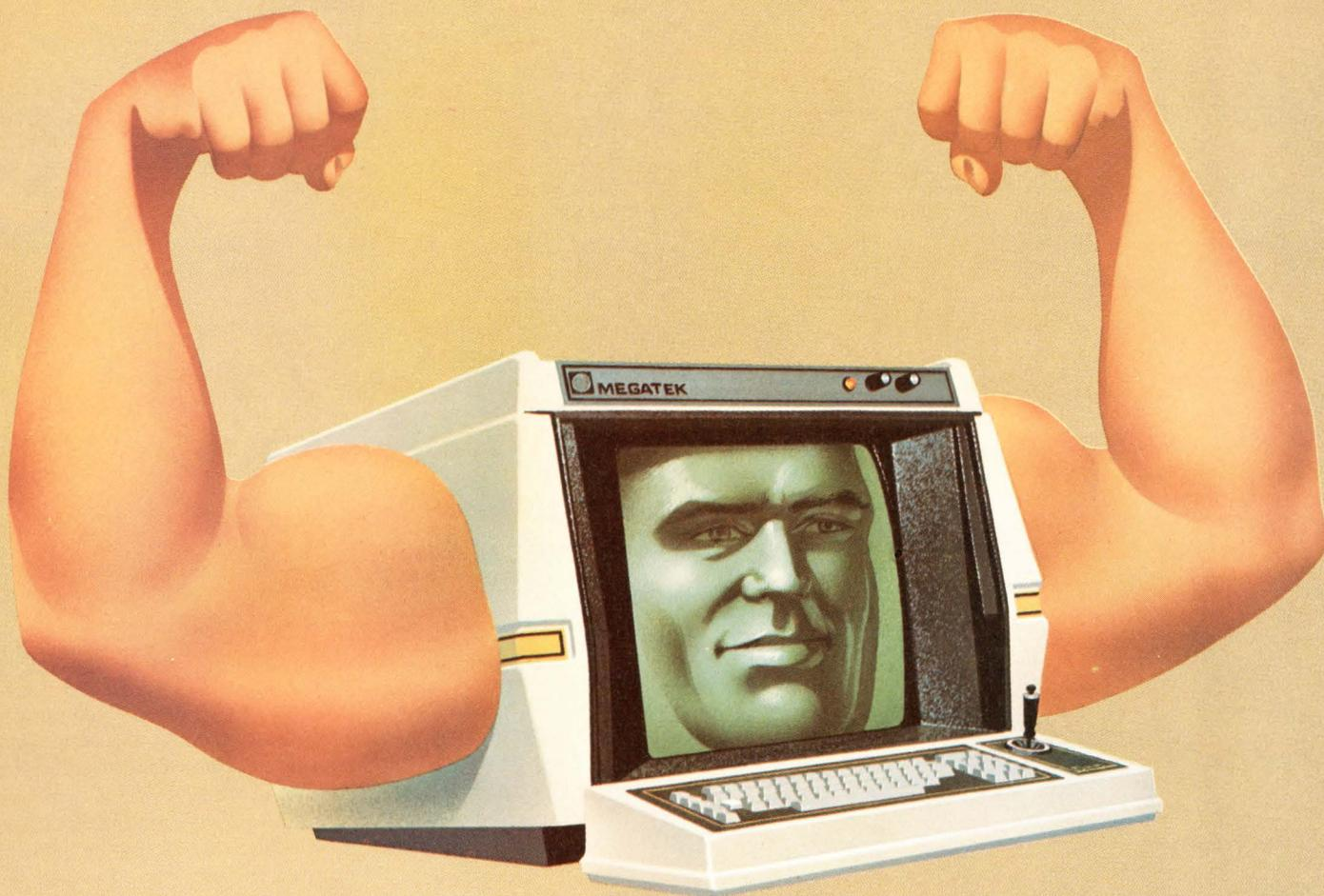

All muscle and no fat.

Most refresh graphic systems are flabby. With lots of features you don't need. Without a few you do.

The MEGATEK 7000 is built lean. You get fast graphics throughput. A high resolution, real-time, interactive display. Complete system modularity. An unmatched refresh graphics system. At a price that makes sense.

A built-in 32-bit microcomputer with a 64K byte, 32-bit wide refresh memory, expandable to 128K. Lets you process graphics data fast. And, saves you host computer time. Add MEGATEK's advanced vector generator and you get unbeatable graphics throughput.

Vectors and characters are displayed instantly. With precision end point matching. And constant intensity. 12-bit resolution is standard. Vector quality that outclasses every other refresh system.

Easy-to-use real-time interactive graphics. Outstanding display



dynamics. Hardware translation, blink, dashed lines. Absolute and relative jump. All standard. And, hardware clip, rotate, scale, and zoom are available as well.

Plus, the MEGATEK 7000 is easy to look at. 16 levels of image intensity. 8 programmable character sizes. The screen is clear and readable, even in a brightly lit room. And, with selective erase, you don't have to blank the screen to change a vector or symbol.

Add a universal computer interface that connects to any host computer. Field-proven software that cuts system development cost. A full line of

peripherals and accessories. Even color, if you need it. And, you have the most powerful refresh graphics terminal for your dollar on the market today.

But, don't take our word. Prove it to yourself. Call or write for a demonstration. And remember, the MEGATEK 7000 is backed by a national service network with fast, hot-line access.

For full details, write or call Peter J. Shaw, MEGATEK, 3931 Sorrento Valley Blvd., San Diego, CA 92121. (714) 455-5590. TWX: 910-337-1270. (European office: 14, rue de l'Ancien Port. 1201 Geneva, Switzerland. Phone: (022) 32.97.20 Telex: 23343.)

The Visible Difference



MEGATEK
CORPORATION

LATEST T Offers Users Mo

Semiconductor technology has had a major impact on vector graphic processing. Application of bipolar technology and tri-state bus architecture has improved throughput rates and permitted more graphics processing power to be concentrated within the graphics terminal, minimizing host computer time and maximizing ease of system expansion.

And, along with improved graphics performance, new semiconductor technology is permitting manufacturers to introduce more quality into the presentation of vector graphic information; high-performance, high-resolution, low-cost vector graphics is no longer a dream. Examining a vector graphic terminal's major components will reveal the impact of state-of-the art technology.

The beam is the key

In refresh vector graphics, pictures are composed of vectors produced when an electron beam selectively excites a display tube's phosphors. But the key to producing good quality vector graphics lies in directing the beam about the screen, and is easier said than done in a high-quality deflection system.

In early vector generators, X and Y deflections were driven by a third-order filter circuit which moved the beam from point A to point B in a fixed period of time. The beam began (in each axis) with zero slope, approached a ramp, and ended with zero slope. This technique resulted in beam movement slower at the beginning and ending portions of the vectors than during the middle. This speed variation caused intensity and focus variations over the vector length.

Modulation of the Z-axis waveform is one method of overcoming the intensity problem. This method of compensating involves a logarithmic relationship between the effect of the Z-axis voltage on the tube and the perceptible intensity. At best, the correction is effective only over a limited range of intensities. The overall approach produces marginal quality images.

Adaptive timing

To achieve a high quality image with constant vector intensity, we use a vector generation technique which em-

SEMICONDUCTOR TECHNOLOGY

More Speed, Flexibility and Standardization

Peter J. Shaw and Walt A. Foley
Megatek Corp.

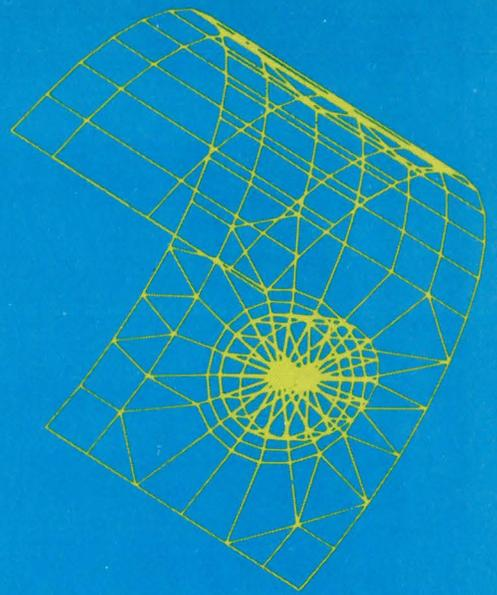

employs a proprietary scheme called Adaptive TimingTM. In essence, this technique offsets for the inductive characteristics of the monitor's magnetic deflection system (**Fig 1**). In this way, the beam is proceeding at a linear rate before being turned on. We have suffered the effect of the lag while the beam is off, and can now write the desired vector at constant velocity and, therefore, constant intensity. A true appreciation for the peculiarities of magnetic deflection systems (and their associated driver components) has produced a design which "adapts" in real time for the different delays required to produce high speed vectors without loss of precise end point matching.

Speed and capacity

While precise beam control may be the key to producing quality images, vector capacity is the key to a graphic processor's usefulness. Beam deflection speeds approach the limits of existing monitor technology at about $1''/\mu\text{sec}$. Assuming zero set-up time, this means it is possible to write one million vector-inches on the screen each second. Using a more typical refresh period of $1/30$ sec, this translates to a vector capacity of 33,333 vector in. at 30 frames/sec.

One must realize that set-up times are not zero, and that vector capacity is closely related to how well the manufacturer control this time. While the number of $10''$ vectors which can be displayed at 30 frames/sec is only reduced by 20% from theoretical maximum by a $2 \mu\text{sec}$ set-up time, the number of $0.1''$ vectors which can be displayed is reduced by 95% from theoretical maximum by this set-up time.

With short vectors, therefore, $0.75 \mu\text{sec}$ improvement in the set-up time (from 2.0 to $1.25 \mu\text{sec}$) is extremely significant in that it almost doubles the short vector capacity.

This short vector example isn't theoretical. The figures used are another result of our use of adaptive timing, through which we have been able to take advantage of the reduction in the necessary settling time for the beam.

High resolution and interpolation

Unlike raster systems or other CRT/ graphic methods which use low-resolution dot matrices, vector graphic systems typically divide the screen into 4096×4096 resolution for which users choose vector refresh systems. To record and store information for all possible 16 million plus points would be impractical. End points of vectors are used instead.

To produce vectors, the beam is driven from position to position. This concept essentially uses a beginning point D/A converted (DAC), an ending point DAC and a ramp DAC. The ending point DACs are constantly shuffled into the beginning point DACs of the next vector, pushing the beam from one point to another as it moves about the screen.

Beginning and ending point data is also used by a high speed normalizing circuit which causes the X and Y integrators to produce a very precisely computed ramp. Summation of the beginning point data and this ramp produce the X and Y deflection signals.

In contrast to a raster system which selects the closest raster element to the true line between beginning and end point, our digital-analog generation scheme can interpolate between resolution elements. The beam is not required to lie on a resolution element; it must only begin and end on a resolution element. (**Fig 2**).

Character generation

Before discussing data flow and component interaction in a graphic terminal, there is one more area in high quality vector systems that we should examine. This is the generation of alphanumeric characters. There are various methods used. Some incorporate hardware curve generators. For example, a cosine generator might be called up to form the bottom of the letter U. The problem with this process is that it is not always possible to align the curves and straight lines accurately. As a result, this method produces readable, through not necessarily pretty, characters. Spending a little more time, drawing the character line by line, is one method that insures readability, even down to

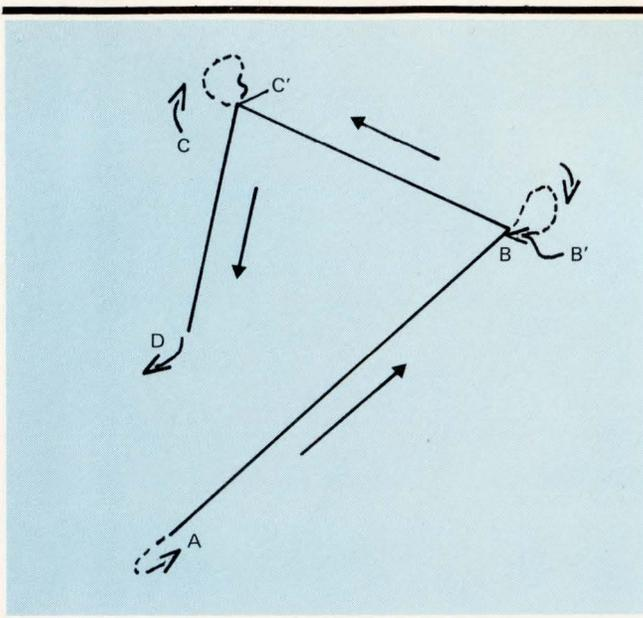

Fig 1 As the beam moves toward B, comparator circuits turn off the unblank at precisely the time the beam passes through B. Beam continues on in somewhat undefined manner and finally settles at point B'. After appropriate set-up time, beam begins from B' and moves toward C. As it passes precisely through B the beam is unblanked and the vector is drawn toward C, where the cycle repeats.

very small sizes. Megatek uses this technique, called stroke generating (Fig 3). But here is where everything we've been discussing comes together: the end-point matching and intensity control have to be perfect if very small text is to be readable.

There is another benefit which occurs from the use of the stroke generated characters. Since each letter is composed of vectors (typically six strokes/character), text may be rotated or scaled along with any picture on the screen characters may be scaled to any increment. Characters can be rotated, scaled or translated at any angle with the full precision of the rotate-translate circuitry.

We've been discussing some of the advanced techniques — the leading-edge ideas — for dealing with vectors. After all, crisp, clear pictures are what you need. But the hardware, too, can affect the speed and flexibility, as can the software.

Typical configuration

Let's examine these other graphic components by discussing the configuration chart for Megatek's new Whizzard 7000, a bus-oriented graphic display system. The 7000's graphic display unit consists of a number of independent modules connected to one another by an asynchronous tri-state bus structure (Fig 4). This advanced bus architecture not only allows for future expansion but makes provisions for OEM-added, optional hardware.

Dual bus

To provide for the real-time, dynamic needs of graphics users, the transfer of data between various devices on the bus must occur at an optimum rate. It is important that in graphic systems, the devices and peripherals be tied in at a level where they are representative of the immediacy of their response. For these reasons, the 7000 uses a dual bus architecture: state-of-the-art, 32-bit tri-state graphics bus, and an independent 16-bit peripheral bus.

On the 32-bit graphics bus we need only concern ourselves with high speed graphics transfers without having to be concerned with peripheral data transfers which are adequately handled by the device-oriented peripheral bus.

Interface

The host interface module ties the dual buses together since it has a need to communicate with modules on the graphics bus and accept instructions from the peripherals bus. But in addition to this hand-shaking, the interface module must buffer and pack data. It is the traffic controller between the unit's 32-bit display list memory, graphic processor, and vector generator structures, and outside world of 16-bit minis.

A universal parallel interface relates to most popular mini and midi computers using the computer's own general purpose interface. It provides programmed I/O or direct memory access control.

Graphic processor

The host communicates directly with the graphic processor when information has been stored in the unit's display list memory. The processor deciphers this vector data and controls the data flow from the dynamic memory to the vector generator.

In the case of the Whizzard 7000, the graphic processor module is controlled by a proprietary, bi-polar, bit-slice μP .

Graphic memory, display list

Matching memory word size with bus width provides the necessary compatibility needed to optimize throughput for high performance graphics. Because the 7000 has a 32-bit-wide data path, the dynamic memory also consists of 32-bit words. Memory is available in 16k word increments.

Peripherals or the host write into the display list memory, and the processor uses this data to dynamically produce a screen image. By examining the function bits in each 32-bit display list word, the processor is able to interpret the contents of the word, which could contain absolute or relative X and Y coordinates; rotation scaling or translation instructions; or it could contain subroutine information.

The stored beam, or vector, information is known collectively as the graphics display list. Called 'pictures' these groupings of run-time instructions are located in Whizzard memory and consist of three parts: header, graphic component and trailer. The graphic component is composed of 32-bit words. (Fig 5).

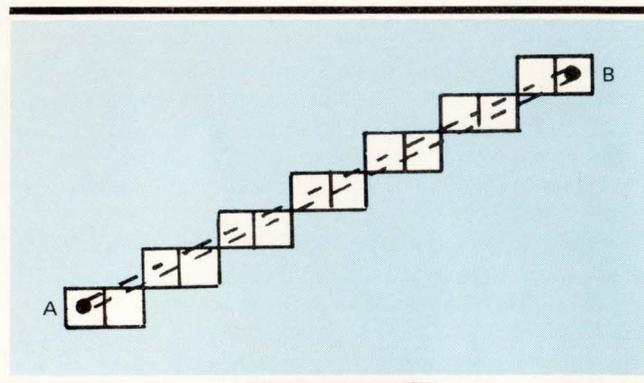

Fig 2 Squares represent stair-step pattern of typical raster system. Note the much better vector representation achievable with an analog vector system (which is dashed in) in that it interpolates between end points.

**C-R-T, C-R-T, alpha-numericity,
ASCII-key, multi-key, programmability,
Blinkity, blankety video-bility,
Up-down-left-right cursing, absolute addressing,
Insert string, delete string, erase and back-tabbing,
Editing,
editing,
C-R-T editing ...**



No bones about it.

What you need now is some straight talk about Smart Editing CRT Terminals.

Selecting the right CRT for your system isn't easy. You're trying to find a fully capable Editing Terminal in a CRT marketplace that's crowded with a dizzying array of contenders at prices ranging all the way from a few hundred dollars to several thousands.

You'll be glad to know that for \$1500 or less, you can buy all the performance, reliability and support you need in a Smart Editing Terminal from at least four manufacturers — ADDS, Beehive, LSI, and EECO, of course. That's the conclusion of a comprehensive, straightforward report that frankly compares your alternatives model by model, spec for spec.

Get it straight — write for your free copy of "Choosing the right Smart Editing Terminal from the crowd of CRT's" today.

EECO editor

EECO, 1441 East Chestnut Avenue, Santa Ana, CA 92701 • (714) 835-6000



Computer Terminals

We'll translate your next computer terminal design into the right ICs.

We make it our business to know your business. We have to. Because we know your future depends on it.

It's no secret that things change fast in your business. Or that success or failure depends on how well you use semiconductor technology in your next computer terminal design.

That's where we come in.

Our people speak your language. They know how to save you time. And money. By helping you select the right ICs for your design. Every time.

Signetics wants to help keep you ahead in the terminal design game. Because if you're not ahead, you're not even a player.

That's why we give you more than just the right product. We also give you the Signetics Commitment. We don't publish specs on it. And it's not scribed on our ICs. But we do market this extra, personal commitment. And it's free.

Our professionals in IC technology and market support are backed by Signetics' six integrated divisions. That means we can combine our total resources in both MOS and bipolar technologies to give you the edge in computer terminal OEM design.

For example, our MOS Microprocessor Division's 2652 is the fastest multi-protocol communications controller in the world at

Rudi Willers, Signetics sales engineer (left), talks terminals with Bo Fredricsson, Qantel's director of R & D.

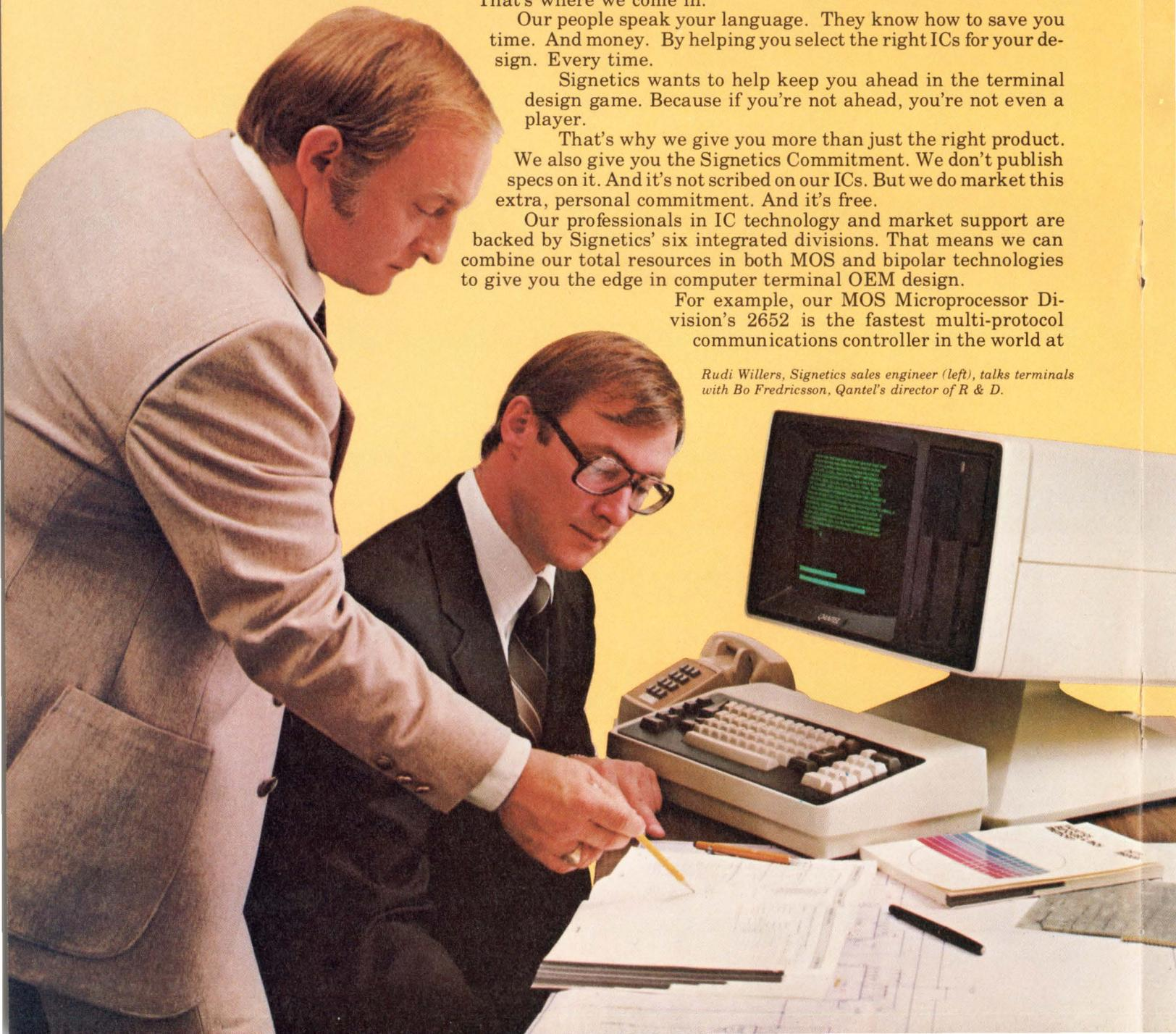

Spoken Here.

2Mbits/second. It's right at home with most high-level protocols.

Every computer terminal OEM looks for unique logic functions. With the smallest amount of random logic practical. And Signetics wants to make it easy for the designer.

Working together, our Logic and Bipolar Memory Divisions have responded to the terminal OEM's demands for speed and flexibility.

We've gone beyond LSI to give the terminal OEM the 8A2000 I²L Gate Array. It's got 2000 gates. And you can customize the 8A2000 to your proprietary needs without losing LSI benefits.

In fact, all you stand to lose is the need to use 50 to 75 random logic packages by going with the 8A2000 in your design.

With our family of field programmable logic, including the FPLA, FPGA, and ROM patch, we make it easy for you to out-design the competition.

And more design freedom's on

the way. We'll soon be offering the world's first Field Programmable Logic Sequencer.

Responding to your needs, our Logic Division created the bipolar 8X300 μ P. Its blazing speed of 4 million operations/second and control-oriented architecture make it ideal for adding state-of-the-art peripherals to your terminal system.

While our field professionals help computer terminal OEMs translate difficult design choices into the right ICs, other Signetics professionals are applying the most advanced technologies into devices to meet the OEM's future demands.

Talk to a Signetics professional. We've bridged the communications gap between terminal OEM and IC manufacturer.

To learn how our leading-edge technologies are making innovation simpler for terminal OEM designers, write us today.

We've got a brochure that tells you how you can put our advanced ICs to work for you. On your own terms.

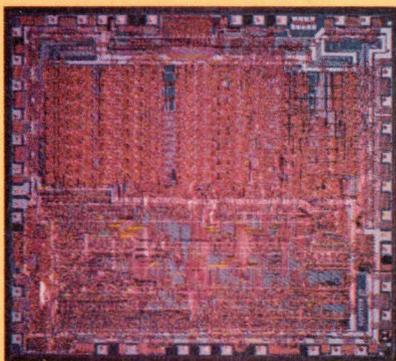

2652 multi-protocol communications controller

signetics

a subsidiary of U.S. Philips Corporation

Signetics Corporation
P.O. Box 9052
811 East Arques Avenue
Sunnyvale, California 94086
Telephone 408/739-7700

To: Signetics Information Services, 811 East Arques Avenue
P.O. Box 9052, Sunnyvale, CA 94086

- Please send your brochure that describes the full range of ICs and capabilities available to the computer terminal OEM.
- My need is urgent. Please have a Signetics professional phone me at ()

Name _____ Title _____

Company _____ Division _____

Address _____ MS _____

City _____ State _____ Zip _____

DD279

Vector generator

The final component of a basic graphics display unit is the vector generator. As can be imagined, it is also one of the most critical — being responsible for directing the beam as it draws the picture vectors. Here is a proving ground for buzzwords. Here is where the readability precision, intensity control and end-point matching mentioned earlier are controlled. Here, too, repeatability and accuracy are proven.

Did you every try drawing a line from A to B, then from B to A? Chances are you'll see two lines over a large portion of the vector path. (Fig 6). Only a true understanding of monitors can eliminate that through repeatability and accuracy.

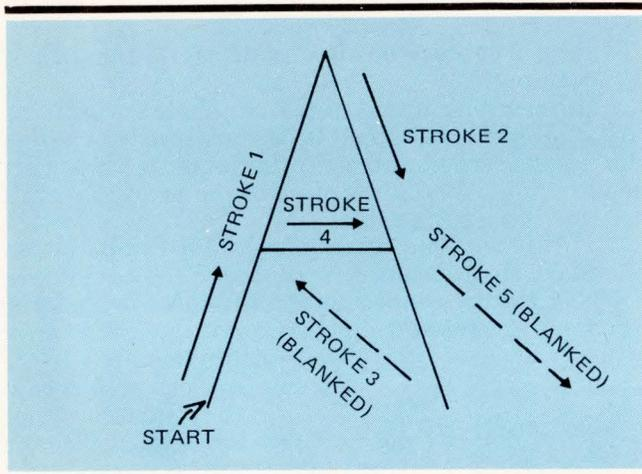

Fig 3 Characters are drawn with strokes, taking advantage of the precise vector generator. This produces an extremely readable character even at sizes below 0.1".

A proprietary vector generator with adaptive timing is responsible for the 7000's fine control. Using an electromagnetic monitor, we produce vectors of constant velocity and constant intensity. Our patented features for vector closure insure precision and accuracy — no matter which way you draw the line from A to B.

Options: intelligent peripheral control

Typically, peripherals such as joysticks, data tablets or keyboards require a tremendous amount of host supervision. Each time the cursor is moved through a new set of coordinates, interrupts are generated as the host tracks the cursor. But in a majority of graphic applications the host only needs those coordinates when data is to be inputted or recorded. There is an awful lot of wasted host processing time. Megatek's philosophy is that the last thing you want to do is to tie up the host.

The Whizzard's advanced technology reduces the host loading required to service these meaningless interrupts through an Intelligent Peripheral Control Unit (IPCU). This μ P-controlled module updates coordinate information without requiring any host interaction. And, there are provisions for up to four joysticks, four data tablets and four keyboards.

To provide this smart peripheral interface, the IPCU ties into both the graphics and peripherals bus.

Dynamic graphics

When dynamic capabilities are needed, such as rotating the picture, scaling the picture up or down, translating to dif-

ferent axes or displaying clipped portions of pictures in individual viewports, the picture information from the graphic processor is intercepted before entering the vector generator.

In the diagram, the Hardware Clip, Rotate, Scale and Translate (HCRST) module controls all these functions. In this module we have a high performance matrix operation which processes X & Y information in real-time.

Vectors which once were contained within specific boundaries might no longer be confined to the same area after having been rotated, scaled or translated, so the resultant vectors are processed by the clipper to eliminate unwanted wraparound, etc. The clipper accepts this input, adds or subtracts vectors as necessary, and sends to the vector generator either new vector information or only the vectors needed (i.e. after clipping).

Two and three dimensional rotation obviously allows the operator or designer to view a problem from every angle. But the 7000 goes one step further. It allows intermixing of 2-D and 3-D pictures on the same screen — simultaneously. This allows the user to work where he is most comfortable in the 2-D world and make the transition to 3-D only when necessary. Not many graphic display units provide this real-world functionality.

Clipping permits only a portion of the display to be shown in separate viewing areas on the screen called viewports. Clip boundaries can be duplicated for different portions of the display list. By using a multiple viewport capability different boundaries may be set.

Hardcopy

Many graphic display units provide facilities for hardcopy output to plotters and/or printers. This graphic information is in vector format and must be converted into some form of printable, analog matrix. Doing this via software has the disadvantage of being slow, not to mention the fact that it ties up the host computer.

Our Rasterizer™ is a vector-to-raster converter, implemented in hardware, again, for the purpose of off-loading the host computer. It looks at the information at the input side of the vector generator, the X and Y end-point coordinates of vectors, and produces raster output. In addition to not tying up the host, it is capable of producing archival quality hardcopy of the entire screen in just 10-15 sec. The advanced techniques employed allow the Rasterizer to process vectors randomly — preprocessing by the host is not necessary to order the vectors.

Light pen

A peripheral such as a joystick relates a crosshair on the screen to X and Y coordinates. With vectors where scaling or rotation has been applied these coordinates lost their significance.

A light pen or a pick device, however, is able to provide information that relates back to an actual display list location. This information is often more useful to the programmer.

Multiple monitors

More and more graphic users are finding applications which require multiple displays. The Wizzard can support two monitors (displays) with a single graphic processor and vector generator. And because the high speed bus is not loaded to capacity, we capitalized on this fact, adding a second processor and generator set, which can support two more monitors.

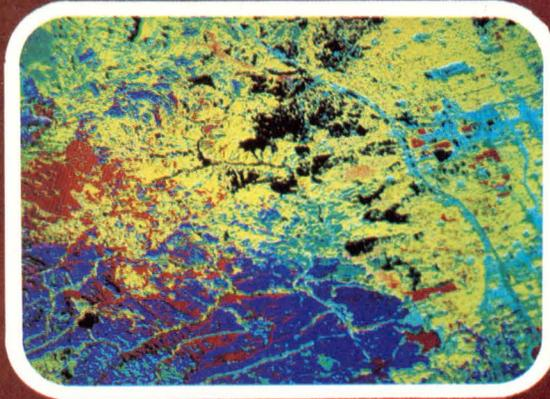

An intelligent solution to image and graphic display problems Higher performance + lower price = optimum systems by Aydin Controls

THE NEW AYDIN CONTROLS Model 5216 Display Computer is the intelligent solution to your graphics and image processing display requirements. Why be locked into the limited capability "packaged terminal" approach now prevalent in the industry? The Model 5216 consists of a family of functional hardware and software modules from which you may configure a display system for stand-alone operation or for integration into your system. Simply select those modules which are consistent with your application. The Model 5216 provides multi-processing capability and multiple buss architecture for separate input/output, display processing, and display refresh functions to enhance system performance and flexibility. Whether you need a low-end alpha/graphic color terminal or a sophisticated multi-image, high resolution image processing display system (or anything in between), the Model 5216 display family is your answer.

SALIENT FEATURES

- High-performance multi-processor buss architecture
- Pixel or graphic DMA block mode data transfer (800 nano-seconds per 16-bit pixel)
- Multiple pixels per word
- Wide selection of display formats including 512 x 512 x 64, 1024 x 1024 x 16, and up to 1024 x 512 x 16 bits per pixel at 60 Hz refresh rate
- Video pro-

- cessing through look-up table RAM at bit rates to over 40MHz
- Built-in vector and circle generation
- Four sizes of alpha characters
- High speed hardware math
- Both parallel and serial peripheral interfaces available
- User programmable.

STANDARD HARDWARE MODULES

- Processor Module (16-bit)
- Processor Expansion Memory (up to 1 megabyte of PROM or RAM)
- Memory Buss Controller (sync and control)
- CPU I/O Module (DMA to host)
- Video Modules (several types available)
- Memory Modules (display formats from 256 x 256 to 1024 x 1024 x 16)
- Mass Storage Controllers (floppy disk and magnetic tape)
- Zoom Controller (2X, 4X, 8X and 16X)
- Hardware Math Modules (including vector/circle)
- Alphanumeric Channel Module (80 x 48 format, 256 unique symbols, 8 colors).

STANDARD SOFTWARE MODULES

- AYDOS Operating Systems
- Software Support Modules
- AYGRAPH 2D or 3D Graphics Modules
- AYGRAPH Image Processing Modules
- Emulation Modules.

Configure your system from the Model 5216 family of Hardware and Software Modules and prove to yourself the cost/performance advantages of AYDIN CONTROLS for your application.

AYDIN  **CONTROLS**

414 Commerce Drive • Fort Washington, Pa. 19034

Phone (215) 542-7800 • TWX (510) 661-0518

One source for all your CRT display requirements

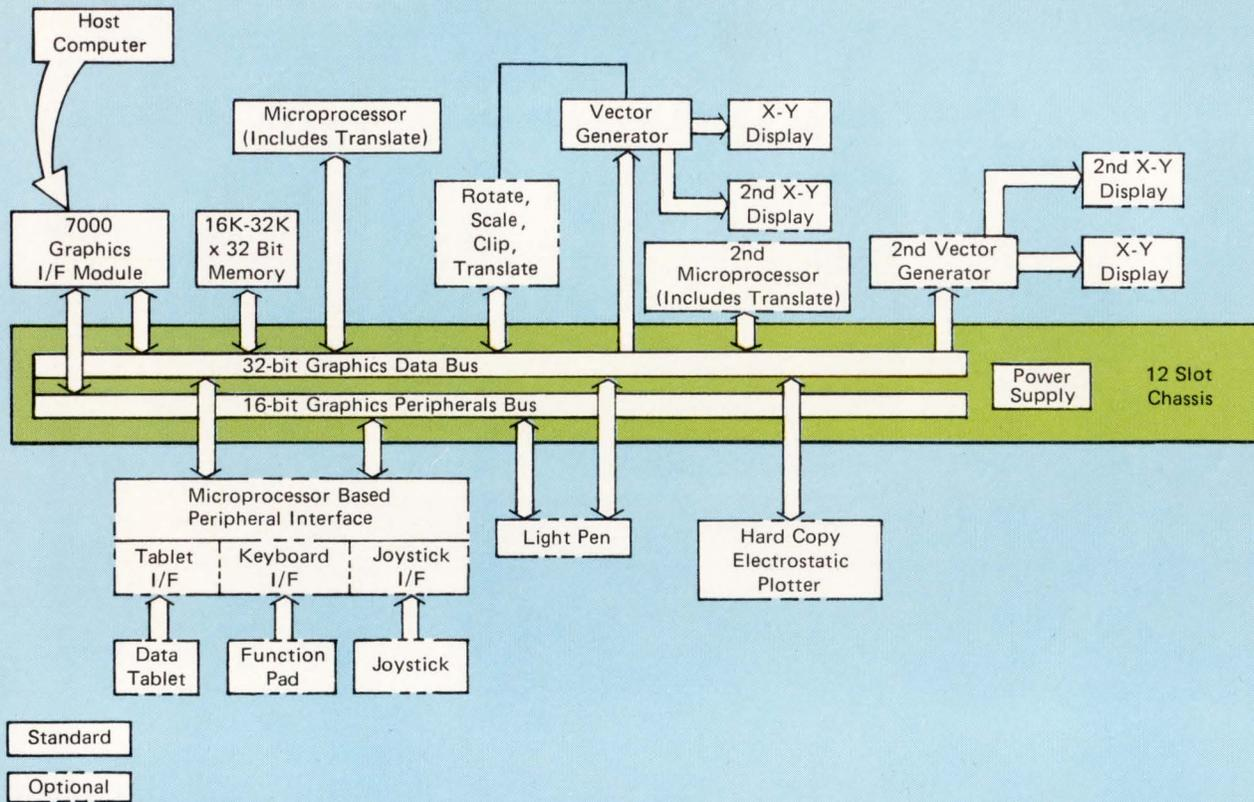

Fig 4 MG 7000 configuration with options.

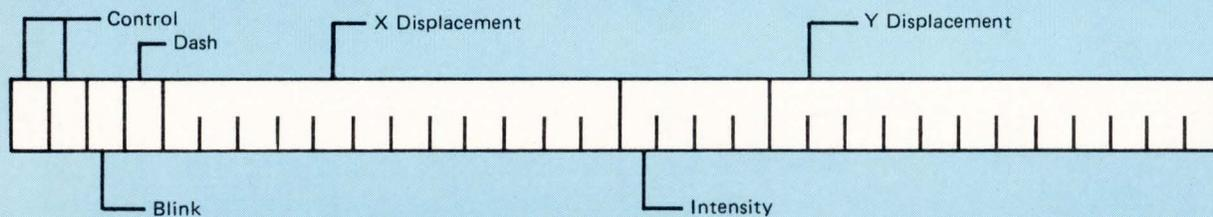

Fig 5 32-bit graphic display list instruction for an absolute vector.

By adding this second processor and generator, vector capacity is shared among the four monitors. In situations where all monitors display the same picture, maximum vector quantity is not reduced.

Also, it can show portions of the same picture on two monitors simultaneously. This might be done in a war games situation with red and blue team locations displayed on their own screen, with an umpire display showing the location of both teams.

Summary

The basic features and diagram components we've discussed are common elements to refresh vector graphic display units. Not only have technological advances in the past few

years benefitted customers with improved quality and capabilities (such as increased throughput and enhanced performance), but manufacturers now offer more capabilities at half the price of graphics systems available three years ago.

Because of advanced graphic processing methods, peripheral control concepts and fast DMA interface of graphics processors, host computers have more time available for general purpose computing. High resolution screens and improved techniques for vector generation allow precise end-point matching and constant vector intensity to produce clear and crisp lines.

Enhanced, interactive dynamic capabilities such as scrolling, zooming and hardware implementation of transla-

Genisco High Resolution Displays.

Let us make your computer graphics 'crystal-clear'- fast!

Your future in graphics and image processing can't help being bright with all the Genisco Raster Display "good-omen" benefits going for you. Like ultra-high resolution, nanosecond processing, reliable performance, synergistic software, and modular architecture — that lets you quickly go "on-line" at minimal cost and expand as your needs dictate. Yet, with all this sophistication they're thin-pocket-book priced.

16K MOS/RAM Refresh Memories that go up to 1280 pixels/line X 1024 lines, in 16 gray scales, and 1024² full color versions. And, they're all directly addressable.

16-Bit User Programmable Graphics Processor lets you realize optimum operation with 150 ns cycle time manipulation, a set of 55 mnemonic instructions, automatic DMA access, selective erase, user selection from 4096 colors or 256 gray shades, and over 32 refresh memory planes control — using a unique "group select" method. We even offer a scroll and zoom, and a character/vector generator.

Versatile Output. Up to 12 monitors can be operated from a single system. TV/video mixing. Remote monitoring. RS232 ports. Automatic "Circumfill". These are but a smattering of the many advanced monitor control benefits offered by Genisco.

Full Complement of Interfaces for most popular minicomputers are available as standards, and we can economically fabricate a specific configuration where a stock unit won't do.

Flexible FORTRAN Software puts you "on-line" quickly, economically. Present offerings include a comprehensive set of Basic Graphics instructions, an efficient Cross Assembler, and our special GRASP package of FORTRAN callable subroutines — to simplify programming of your particular display configurations. With all this to back your display developments, a bright and 'crystal-clear' future is assured.

Contact Genisco, a name that has been synonymous with technological advances for more than 30 years, for all the particulars — and get a fast start on the path to good fortune.

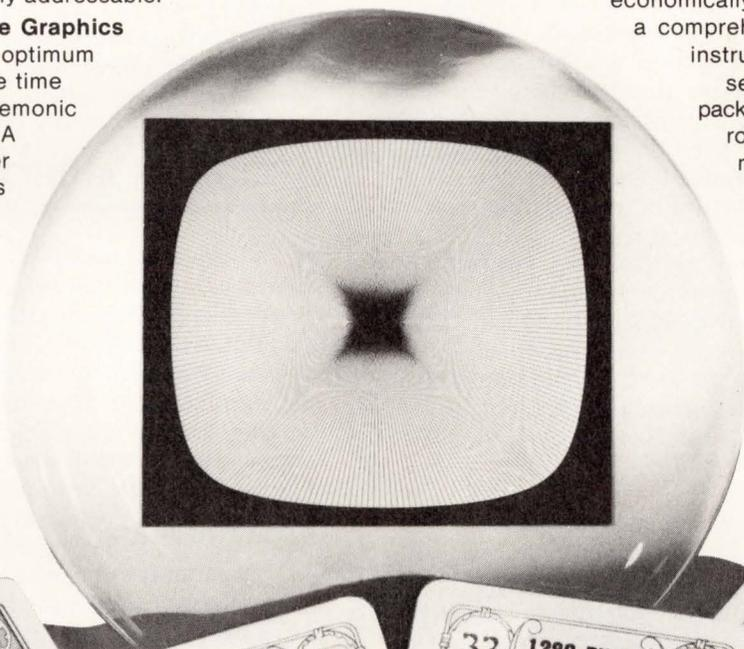

GENISCO COMPUTERS

A DIVISION OF GENISCO TECHNOLOGY CORP.

17805 Sky Park Circle Dr., Irvine, CA 92714 • (714) 556-4916



CIRCLE 32 FOR SALES CONTACT. CIRCLE 33 FOR LITERATURE ONLY.

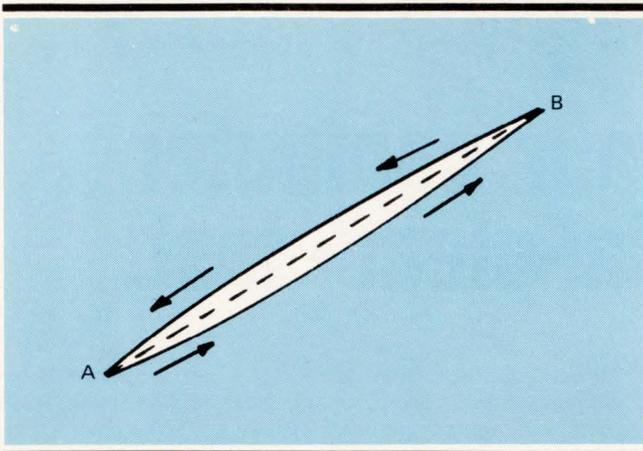

Fig 6 Beam moves from A to B and then back. Deviation from precise overlap is exaggerated for illustrative purpose. High quality vector generators control this separation to less than a beam width.

tion, clipping, rotation and scaling provide more flexibility, and greatly improved throughput rates and the quality. There is no need to accept second rate vector quality where drawing speeds require fast vector generation.

And stroke driven, hardware generated characters are crisp, readable, and can usually be manipulated (scaled and rotated) a finite number of ways through the hardware — and infinite ways with software. Color, variable intensity, and cursor definition have added to the adaptability of today's superior graphics products.

When you consider the increased memory and vector capabilities of graphic terminals, the variety of vectors which can be handled (relative, absolute, incremental) and improved methods of interfacing with I/O peripherals which increase throughput, it is obvious that refresh graphic product manufacturers are constantly improving their products and making them easier to use.

Future trends

In addition to superior graphics, other considerations exist. Not unlike other information processing market segments, graphics processing has evolved. At the beginning of the cycle manufacturers presented the concepts and said: "Here is a wonderful idea; let's see what you (the market) can do with it." Users discovered graphics to be a very useful tool and found and defined improvements and refinements which the industry adapted. But the industry has matured, and now users and manufacturers must address other considerations.

Future trends will continually emphasize superior quality and enhanced capabilities. But east of implementation, software and modularity are some non-technology-related aspects that users are beginning to address.

Modularity is especially important to the OEM as it gives him the opportunity to satisfy his customers' sophisticated applications requirements at lowest cost. Using the building block approach, the OEM can design around a standard shopping list of hardware; he isn't locked into one configuration.

Modularity means the OEM can buy as little or as much as he needs. He can get as little as a vector generator and vector processor, the hardware, or he can buy a graphics terminal or a complete graphics processing system. As graphic equipment becomes more computer independent — not tied to one mainframe — it becomes more important that universal computer interfaces, communications capa-

bilities, remote graphic processing configurations and ability to add more hardware features must be available for the user.

The most sophisticated OEM applications may require, for reasons of cost-competitiveness, only the most difficult-to-duplicate parts of the graphic systems — the proprietary graphics hardware. The OEM should have that purchasing option, allowing him to tailor his application system more efficiently.

On the other spectrum end are those who need full-blown graphic processing systems, CPU included, to which only the application software need be added. The man in the middle is very often one who needs a graphics processor to speed some graphic workload; he is buying specifically the graphic processor to speed some graphic workload; he is buying specifically the graphic terminal, putting it with his computer and adding software to it. He needs all the graphic equipment, such as the graphic processor/vector generator, refresh memory for the monitor and graphics peripherals.

User demand for this variety of choice from graphic equipment manufacturers will keep growing, and manufacturers will structure their marketing to offer OEM purchasers the widest choice of advanced graphics hardware, terminals and systems. DD

ABOUT THE AUTHORS

Peter J. Shaw obtained his B.E. (EE) degree in Engineering from the City College of N.Y. in 1968 and his Masters of Business Administration (MBA) from the University of Connecticut in 1971. Peter joined Megatek Corp. in 1975 as Director of Marketing. He develops a sales and marketing organization for the company's computer graphic line. In addition to being responsible for increasing the sales of the company's inexpensive graphic interface line, his responsibilities also include developing the company's market position for its new graphics systems equipment. As Director of Marketing, Mr. Shaw provides MEGATEK with direction for new product and market areas.

Previously, he was associated with Talos Systems Inc., Scottsdale, AZ as Marketing Manager and at Perkin-Elmer Corp. as a Systems Engineer in their Optical Technology Division, Danbury, CT, where he authored specs for integrated systems performance evaluation and developed software requirements for collection, compression and analysis of complex systems test data. Peter has also developed deep submergence systems and is the inventor of a Submersible Footage Readout Device.

Walter A. Foley obtained his M.S. in Aeronautics and Astronautics from M.I.T. (1970) and joined Megatek in 1972 as a Senior Engineer and Manager of Digital Systems. He was named a Vice President in September 1973 and develops digital systems, including the interfacing of minis to analog/digital data acquisition and display systems. Walt is designing and marketing an inexpensive mini display interface line to permit economical presentation of full graphics on lab-type scopes or larger X-Y displays. Walt is a Commercial Pilot and Certificated Instrument Flight Instructor. He is a member of Sigma Chi, I.E.E.E. and the I.E.E.E. Group on Aerospace and Electronic Systems.

Rate this article: Circle 4L, 4M or 4H on Reader Inquiry Card.

A Beautiful Way To Interface



IQ 140

SOROC's first and foremost concern, to design outstanding remote video displays, has resulted in the development of the IQ 140. This unit reflects exquisite appearance and performance capabilities unequaled by others on the market.

With the IQ 140, the operator is given full command over data being processed by means of a wide variety of edit, video, and mode control keys, etc.

The detachable keyboard, with its complement of 117 keys, is logically arranged into 6 sections plus main keyboard to aid in the overall convenience of operation. For example, a group of 8 keys for cursor control / 14 keys accommodate numeric entry / 16 special function keys allow access to 32 pre-programmed commands / 8 keys make up the extensive edit and clear section / 8 keys for video set up and mode control / and 8 keys control message and print.

Two Polling options available: 1) Polling compatible with Lear Siegler's ADM-2. 2) Polling discipline compatible with Burroughs.

IQ 120

The SOROC IQ 120 is the result of an industry-wide demand for a capable remote video display terminal which provides a multiple of features at a low affordable price.

The IQ 120 terminal is a simple self-contained, operator / computer unit.

The IQ 120 offers such features as: 1920 character screen memory, lower case, RS232C extension, switch selectable transmission rates from 75 to 19,200 bps, cursor control, addressable cursor, erase functions and protect mode. Expansion options presently available are: block mode and hard copy capability with printer interface. The IQ 120 terminal incorporates a 12-inch, CRT formatted to display 24 lines with 80 characters per line.



165 FREEDOM AVE., ANAHEIM, CALIF. 92801
(714) 992-2860 / (800) 854-0147

NEED MASS STORAGE FOR YOUR MINI ?

Try 1/4" Cartridges

Jack Olson
Western Peripherals Div., Wespel Corp.

If you are considering the 1/4" data cartridge for your particular application, carefully examine various system configurations. Data cartridge systems offer unique advantages.

Within their capacity, data cartridge systems cut costs by replacing systems using more expensive tape and disk drives, or provide augmentation, and offer greatly increased capacity over cassette systems. Not only that, but their media is much more rugged when compared to floppy disks.

The data cartridge

The data cartridge is a 1/4" magnetic tape wound on two reels mounted to a precision metal base. A single iso-elastic drive belt contacts the outside tape layer on both reels and a belt capstan, which is the internal force that contacts the external drive motor and moves the tape via the isoelastic band (Fig 1). This whole assembly is encased in a clear plastic protective case — a rugged, flat 2 2/3" x 4" x 6" envelope. The cartridge provides write protecting and tape-end sensing.

The tape is recorded on four parallel tracks generally one track at a time in serial data fashion at a 1600 bpi density, or in some newer drives, at 6400 bpi. Although other densities exist, as well as drives that record the four tracks simultaneously, they are less common.

Construction affects media

The iso-elastic band drive simplicity provides system limitations. While the common single driving source for both supply and take-up reels eliminates using two independent

servo systems, the elastic band does stretch. The result? It's much like driving the reels with a spring, thus limiting how fast the reels accelerate to a constant speed, or decelerate to a stop from that speed. *This limitation dictates the minimum size of the inter-record gap (IRG).*

Since data can't pass the head

with tape accelerated or decelerated — it is unreadable at low velocities — an erased portion of tape or inter-record gap is used between each data block used to start/stop the tape.

Now, the higher the R/W speed, the longer it takes to get the reels up to speed, thus taking a longer the IRG. We want maximum tape

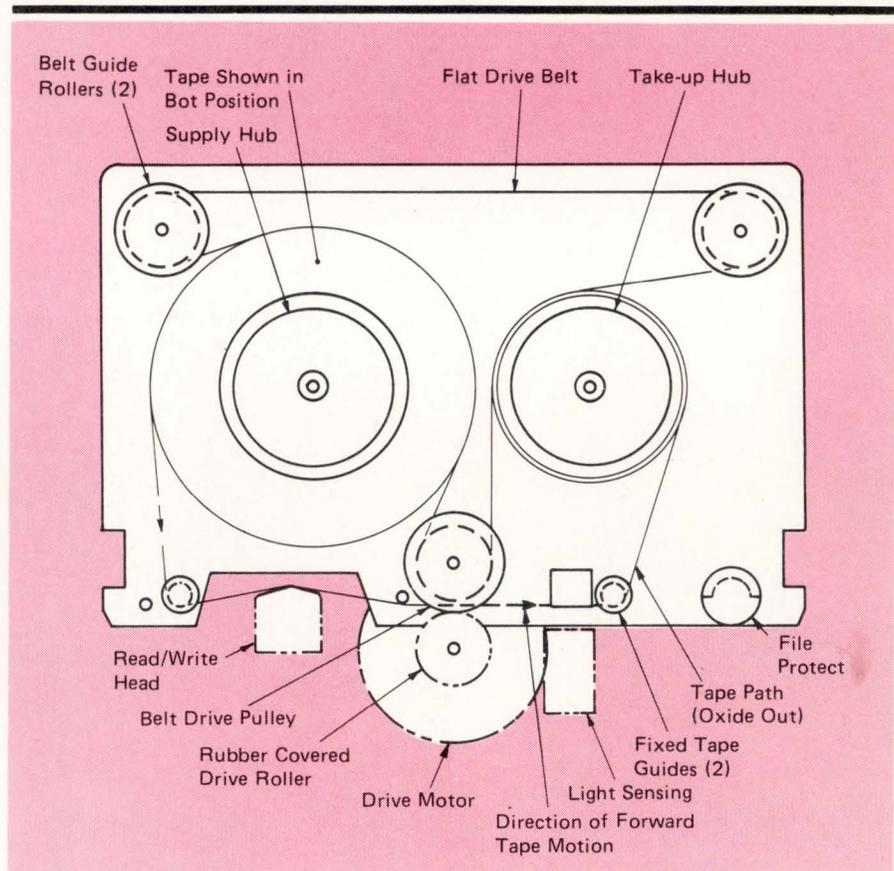

Fig 1 The 4" X 6" transparent data cartridge shows inner mechanisms and how the drive roller contacts belt capstan. (Courtesy of American National Standards Institute, Inc.)

Xylogics Technology Delivers an LSI-11[®] Cartridge Disk Controller.

Xylogics advanced state-of-the-art technology has done it again.

Now you can get the Model 510 Wizard, the only microprocessor based hard disk controller on a dual width board. This means fewer electronic components and best of all, superior controller performance in a cost-effective package.

The Model 510 Wizard provides the LSI-11 user with the on-line storage capacity flexibility of cartridge disk technology. Emulating the RKV11, the self-contained bootstrap permits direct start-up of RT-11 without need for a REV11 card. Subsystems using the Model 510 Wizard are available with 5MB, 10MB and 20MB cartridge disk drives.

Xylogics also offers complete LSI-11 based systems with software to meet most applications.

At single quantity price of only \$1995, including ROM bootstrap loader, the Model 510 Wizard looks good. Add in quantity discounts, performance, and reliability that comes from Xylogics technology and you'll see that Xylogics delivers outstanding results.

Call or write today.

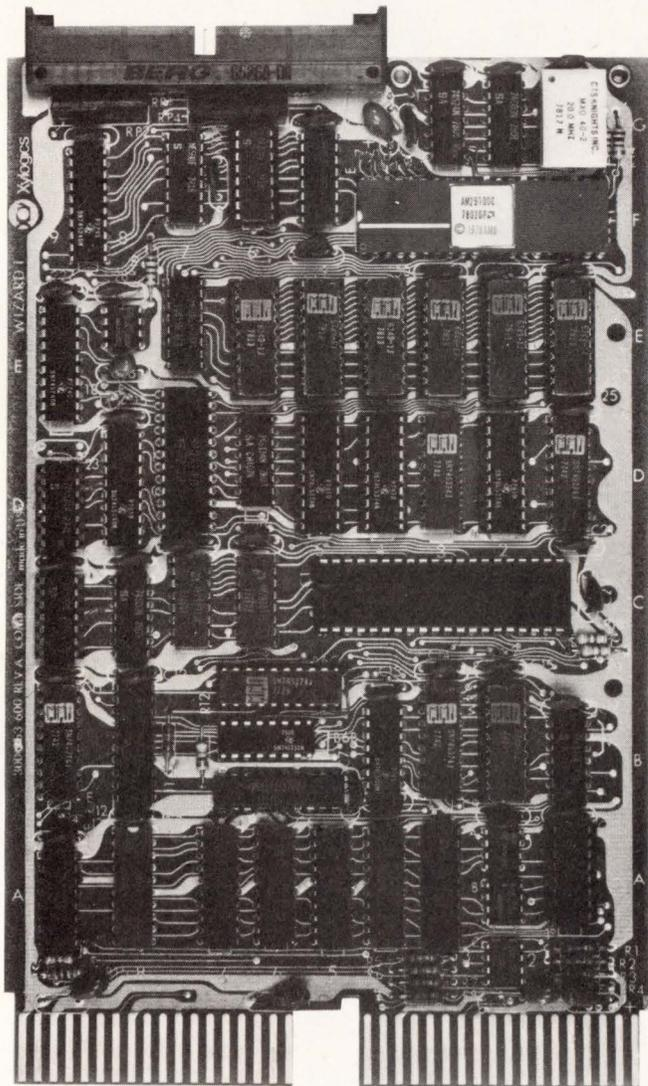

Xylogics

[®]LSI-11 is a registered trademark of Digital Equipment Corp.

Xylogics, Inc., 42 Third Avenue, Burlington, Massachusetts 01803 (617) 272-8140

We did it with . . . innovation/imagination/integrity

Flicker-free and ultrahigh resolution color TV displays...

You can have your choice with the Model 374.

1024 x 512 pixel graphics displayed at a non-flicker, 60-Hz refresh rate. Ideal for the display of computer graphics.

or

1024 x 1024 ultrahigh resolution pixel graphics displayed at a 30-Hz rate using 2:1 interlace. Video bandwidth in excess of 30 MHz assures that resolution is not electronically limited.

Write or call Dick Holmes for a Model 374 descriptive brochure.



Electronic Image Systems

Division of Systems Research Laboratories, Inc.
2800 Indian Ripple Road • Dayton, Ohio 45440
Phone 513/426-6000 • TWX 810/450-8621

devoted to data and minimum for IRG's. The "total tape available/actually used for data" or "figure of merit for tape efficiency" ("tape utilization" factor) is related to the R/W speed and to the blocking size (amount of data in a single record).

An example

Let's see what effect this has on your application if you want to back up a 28 Mb disk drive. Let's say the drive stores 17 Mb of data on one 450' cartridge, or 34 Mb capacity on two cartridges. Now, 28/34 or 82% of total capacity must contain data, with 17.6% left for IRG's.

In other words, there are 21,600" of linear recording length/cartridge (450' x 12" x 4 tracks). 17.6% of

virtually all computers come with RS-232 ports or have them available, connection problems are minimal with no special drivers required.

However, since the cartridge system must interpret information coming across the line for function commands (as well as data), it is unsuited to binary recording because it's probable that a particular combination of purely binary data will imitate and be interpreted as a command function.

Also, since the RS-232 line's data rate is dissimilar from the drive's rate, it needs data buffers. If a constant, continuous data stream is desired, the cartridge system must have dual or "ping-pong" data buffers, so one buffer can accumulate data while the other is dumping onto the tape.

TABLE 1 - COMPARISON OF TOTAL CARTRIDGE CAPACITY AS A FUNCTION OF BLOCK LENGTH

Bytes/ Block	450' Data Cartridge Capacity			½" Mag Tape 2400' (For comparison to cartridge capacity)	
	6400 bpi Serial	1600 bpi Serial	1600 bpi Parallel	800 bpi	1600 bpi
4096	13.8Mb	4.01Mb	3.44Mb	20.5Mb	37.3Mb
2048	11.6Mb	3.78Mb	2.89Mb	18.6Mb	31.3Mb
1024	8.77Mb	3.44Mb	2.19Mb	15.6Mb	23.7Mb
512	5.9Mb	2.89Mb	1.48Mb	11.8Mb	16Mb
256	3.5Mb	2.2Mb	0.89Mb	8.0Mb	9.68Mb

21,600 is 3801.6" for nothing but IRG's. At 30 ips (the most common ANSI standard speed) the IRG is 1.2" long (also an ANSI standard); and since there is one IRG for each data block, and since 3801/1.2" yields 3168 IRG's, then data is divided into 3168 blocks. Since you're going to put 14 Mb (half of the 28 Mb disk drive) into 3168 blocks, you need at least 4420 bytes/block with nothing left over. Add some control blocks (file marks) to separate each disk file along with some safety margin, and the blocking factor is now raised to 6,000 or even 8,000 bytes. *It is immediately apparent that to efficiently use the data cartridge, long block recording is required.*

AVAILABLE SYSTEMS

There are three types of Data Cartridge Interface Systems (DCIS): RS-232 Serial Interface, Non-DMA Parallel and Parallel DMA.

RS-232 Serial Interface

The first and most common DCIS is the RS-232 Serial Line Interface. Since

The size of data buffers — generally 256, 512, 1024 or 2048 bytes — also determines maximum block size. **Table 1** shows how much capacity a 450' cartridge can store at these blocking factors. Note the comparison in storage capacity of the 1600 versus 6400 bpi system with smaller blocks. At 256 bytes/block, the 6400 bpi system holds only 50% more data than the 1600 bpi can. While at 2048 bytes, the ratio is 3-to-1.

Do you need to load programs, monitor a communications line or record direct key-to-tape? Then choose RS-232. In these cases, the limited blocking factors of the data buffers and inefficient tape usage are more than off-set by handling ease, small cartridge size and substantially enhanced capacity when compared to cassettes, paper tape or floppy disks.

Non DMA parallel systems

These systems generally emulate an existing device such as a DEC or Data General cassette or Linc-tape. They transfer a byte or word at a time and

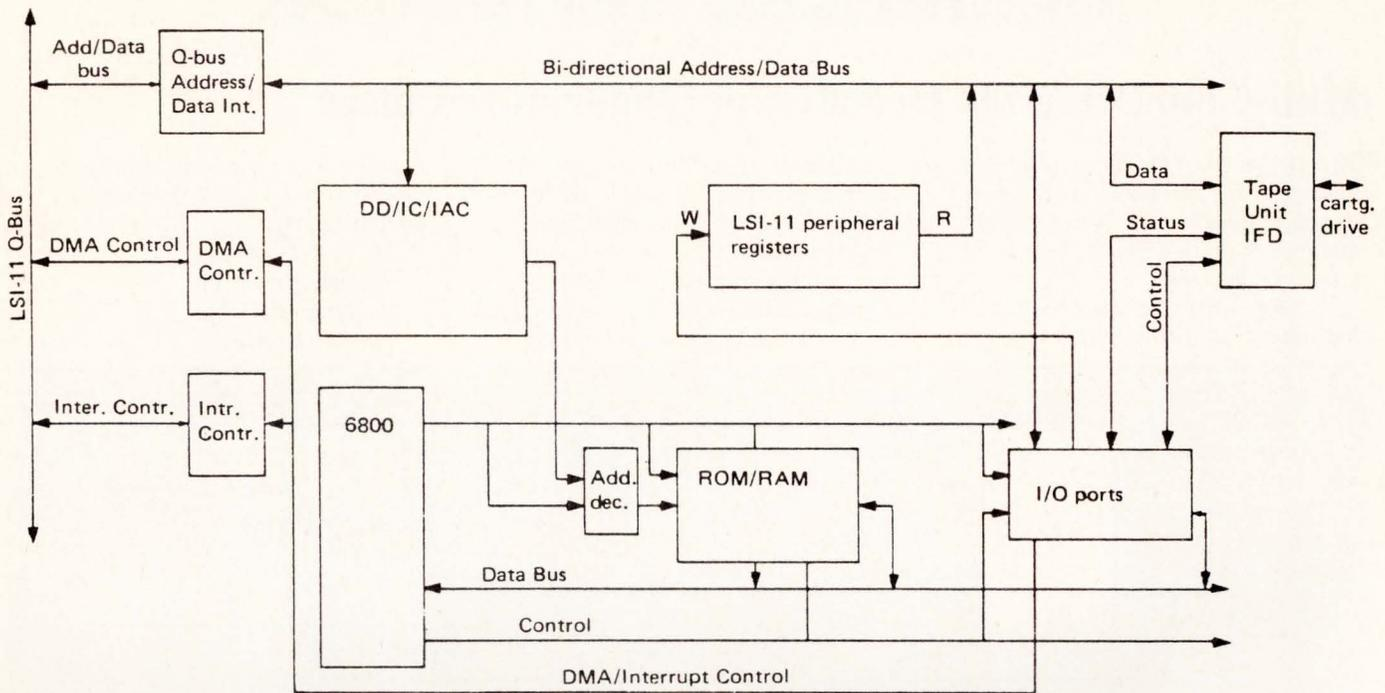

Fig 2 This TC-160 System block diagram shows LSI-11 peripheral registers (status, CMD, byte count, CAM address, data). Both control and address lines enter RAM and 2K X 8 ROM, with address decoder output to ROM. Though drawn in one block, obviously ROM/RAM outputs separately to the data bus.

are compatible with existing software.

Because the interface does not need byte or address counters, it is relatively simple; and unlike the RS-232 system, it readily handles binary recording, and blocking factors become a function of software.

Tradeoff is the amount of computer overhead required to transfer data, since each byte requires execution of ten or more instructions. If you perform real-time, high-speed data acquisition, then computer time may be at a premium. If you are backing a disk, the amount of time used to service the tape cartridge system grows out of proportion to that required by the disk. Simultaneous operation of disk and tape becomes impossible or marginal at best because there are not enough computer cycles left to simultaneously transfer from both devices. If overhead time isn't critical, this is a reasonable way to go.

Full-DMA emulation 1/2" systems

These are truly high end performers that offer emulation of 1/2" tape systems to the extent that computer overhead is held to a complete minimum.

Controllers such as the TC-170 for Data General CPU's transfer 16-bit words at a time via high speed DMA. A bit-slice μ P system allows all for-

matting and byte packing for 1600 bpi serial, 1600 bpi 4-track parallel and 6400 bpi serial to be contained on one embedded PC board, with its controller running up to eight drives.

Blocking factors are a function of software with these systems; and since emulation is completely transparent to the operating system, all conventional backup save-or-dump software utilities are fully usable.

The 6400 bpi MFM formatting offers unformatted capacities up to 15.2 Mb on a single DC-450 (450") cartridge with a 4 K blocking factor. Data is written on four tracks in serial mode.

With 1600 bpi phase encode 4-track parallel format, writing/reading is done in a single pass with up to 4 Mb of data on a single cartridge.

The 1600 bpi phase encode 4-track serial also has a total storage capacity of 4 Mb. TC-170's 32-byte write and read data buffers provide greater flexibility in assigning priorities on the computer.

Hardware and software compatible with all NOVA and Eclipse Series and other Data General emulating computers, the TC-170 board plugs into a single slot embedded in the computer and connects with the tape drive through the rear of the computer via standard backplane panel.

DEC LSI-11 users also can employ a Parallel DMA System using controllers (Fig 2) and having the same trimode formatting that allows users to select 6400 bpi MFM, 1600 bpi phase encode four-track parallel or 1600 bpi phase encode four-track serial formatting.

TC-160 is hardware compatible with all LSI-11 series computers: the two controller boards plug directly into the computer Q bus. It's also software compatible to all operating systems or utilities having DEC TM-11/TU-10 support. This controller handles up to eight data cartridge drives, and a 16-byte data buffer eases Q-bus priority positioning.

Applications such as backup for an LSI-11 Winchester disk system that employ the 6400 bpi data cartridge instead of big-reel tape drives cut equipment costs. It's useful in portable or airborne applications, where light weight and reduced equipment space are important.

Drives from Kennedy, DEI, Tandberg, Qantex and others offer compact packaging, rugged construction, positive cartridge retention to complete dust sealing and other features. No drive has all features, so investigate before choosing the drive you need for your application. DD

DESIGNERS' NOTEBOOK

Half-Chip Direction Decoder for Quadrature Pulses

This circuit must be the simplest configuration for extracting unambiguous direction information from a pair of quadrature pulse trains, as from an incremental encoder.

An edge-triggered bistable stores the state of ϕ_1 at the instant when ϕ_2

goes HIGH. If, as illustrated, ϕ_1 lags ϕ_2 then D will always be LOW at the leading edge of the clock pulse and Q remains LOW. If the count direction is reversed so ϕ_1 leads ϕ_2 , Q goes HIGH at the next positive transition of ϕ_2 . Q is static during the

negative transition of ϕ_2 , leading to unambiguous counting in these circumstances.

Dr. A. M. Calverd,
21 Manygate Lane,
Shepperton,
Middx., England

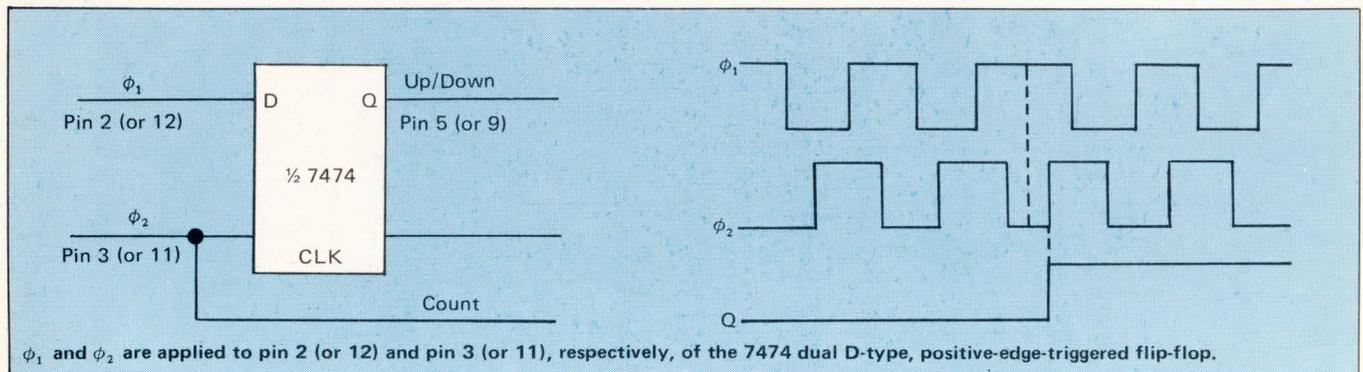

ϕ_1 and ϕ_2 are applied to pin 2 (or 12) and pin 3 (or 11), respectively, of the 7474 dual D-type, positive-edge-triggered flip-flop.

Rate this design: Circle 6, 6L, 6M or 6H on Reader Inquiry Card.

Simple Digital Pulse-Programming Circuit

This pulse-sequencing circuit uses only a shift register and Exclusive-OR gates. It is sometimes necessary to generate a sequence of pulses having precise variable widths and delays. Multivibrators work in these applications, but have the drawback that they require precision outboard capacitors and resistors to maintain accurate time periods. They are also sensitive to temperature fluctuations. Certain all-digital circuits, such as recirculating shift registers and Johnson counters, can produce variable-delay pulses; however, these either do not give variable widths or require an initialization sequence.

The all-digital circuit shown in the figure, developed by us for JPL, produces pulses of variable delays and widths, using only standard IC Exclusive-OR gates and a serial-in-data-transition at the data input triggers the sequence of pulses. The next transition is negative, but is not allowed to occur until N clock periods later, where N is the number of stages in the shift register. The shift register propagates the data edge at the clock rate.

The Exclusive-OR gates compare the states of different sections of the shift register. When the two outputs monitored by a gate are different, the gate produces an output as long as the states are different. Hence, each gate

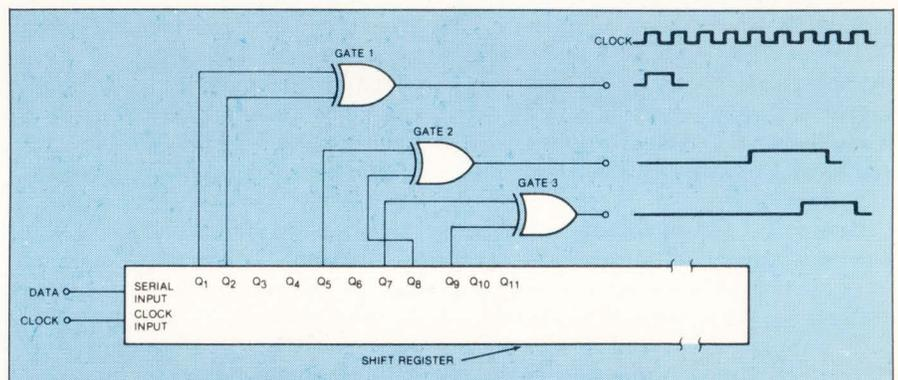

This Pulse Programming Circuit uses only a shift register and Exclusive OR gates.

Rate this design: Circle 7, 7L, 7M or 7H on Reader Inquiry Card.

produces a pulse delayed by the time corresponding to the propagation time of the data from the input to the first tap connection of the gate. The pulse width is determined by the propagation time of the edge from the first tap location to the second tap location of the gate.

As shown, gate 1 is connected between the first two taps Q_1 and Q_2 of the shift register. Therefore, the output of gate 1 produces a pulse beginning with the first positive clock transition following the data edge; its width is exactly one clock period, T.

The output from gate 2 is delayed with respect to the leading edge of output 1 by precisely four clock per-

iods, and it has a duration 2T. The pulses can overlap partially or completely, depending on the relative positions of the gate connections along the shift register.

This circuit can be used in sample-and-hold and analog-to-digital conversion sequence control, multi-phase-clock logic, precise delay control, computer control logic, edge detectors, and in other timing applications. In addition, the circuit can provide a simple means to generate timing and control signals for data transfer, for addressing, and for mode control in microprocessors and minicomputers.

James L. Langston, Texas Instruments, Inc.

PRODUCT HIGHLIGHT

Greatly Expands Capabilities

Basic Designed For Intellec Development

BASIC-80, a high-level language and interpreter was announced today by Intel's Microcomputer Systems Div. BASIC-80 adds to the utility of Intel's Intellec[®] Microcomputer Development Systems by providing a convenient, inexpensive facility for applications programming and problem solving, as well as an aid for microprocessor systems development.

BASIC, an industry-standard, high-level programming language and interpreter, is intended for easy learning and use by novices and experienced programmers. It is an acronym for Beginner's All-purpose Symbolic Instruction Code and is an easy-to-learn, algebraic programming language that is especially adapted for use on minicomputers and time sharing systems. Born in America at Dartmouth College, NH, in 1964 as a simple computer language for beginners, BASIC proved so popular it has been copied and extended by many computer makers, colleges, universities and time-sharing services. Soon many dialects came into existence; and a program written in one was not likely to work on a microcomputer committed to another. Although it is well-suited for programmers writing programs of modest complexity in scientific, business and many other application areas, more elegant and powerful languages are favored by professional programmers for certain applications. But since BASIC is adequate for most uses and because it is so widely favored, its widespread usage will continue.

The interpreter provides an interactive environment which allows faster and easier program development, testing and debugging. BASIC is widely used for a variety of problem solving applications. Extensive software exists for business applications such as order entry, accounts receivable, accounts payable, inventory control and for engineering applications such as statistical and numerical analysis.

Standard ANS 78 BASIC features provided by BASIC-80 include: string and numeric constants, variables and arrays; FOR...TO...STEP...NEXT statements for loop execution; IF...THEN statements for conditional execution; ON...GOTO statements for calculated branching; and GOSUB/RETURN for subroutine calls and returns. Standard ANS 78 BASIC also allows the user to define single statement functions. Its built-in scientific functions include: ABS, EXP, INT, LOG, RND, SGN, SQR, ATN, TAN, COS, and SIN.

The BASIC-80 extensions provide access to the Intellec system disk files for full sequential and random disk file input/output. They include support for the Intel single and double precision floating point standards and provide for integer and string data types with extensive string manipulation capabilities. Language extensions include direct read and write of the CPU input/output ports, direct memory read and write through PEEK and

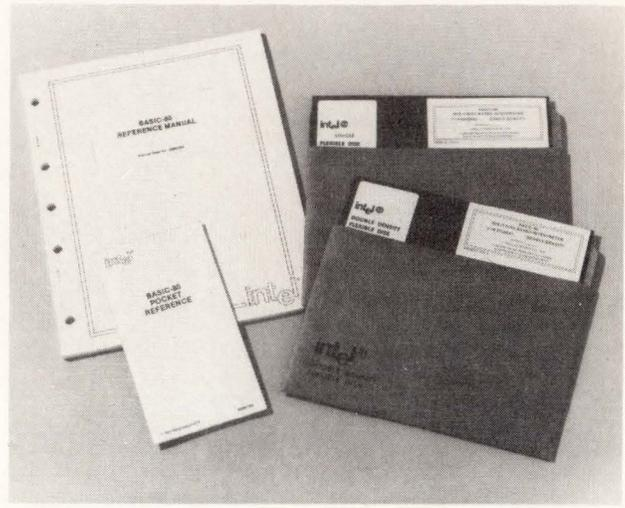

BASIC-80 package includes reference manuals and two diskettes.

POKE functions, a formatted print statement with the PRINT USING function and IF - THEN statements extended with an ELSE clause.

Other BASIC-80 extensions include Boolean Operators and operation with matrices with up to 110 dimensions. To assist in debugging, Intel BASIC-80 also includes user directed error trapping and handling functions plus a program execution trace command.

Adds To Value of Development Systems

The addition of BASIC-80 to the Intellec Microcomputer Development System product line gives the microprocessor development system user greatly expanded capabilities. It provides a local computation facility for the solution of engineering and business management problems as well as a prototyping tool for other microcomputer software, such as PL/M-80 and FORTRAN-80. BASIC is an interpretive language which is easy to understand and to learn so that results can be obtained quickly. It fits well with the computation resources of the development system, and allows subroutines written in other Intel languages such as FORTRAN-80, PL/M-80, or 8080/85 Macro Assembler to be called from the BASIC-80 programs.

Basic-80 can be added to any of Intel's Intellec Series II or MDS-800 series microcomputer development systems with 48K bytes of RAM and at least one disk drive. It is available on single or double density diskettes; order product code MDS-320. The price is \$750 for diskettes and accompanying manuals.

Intel Corp., 3065 Bowers Ave., Santa Clara, CA 95051
(408) 249-8027.

Circle 160

FREE! SPEED READING COURSE.

DECITEK's free SPEED READING COURSE gives full details on new Model 262D9 desktop punched tape reader. (The model that reads

300 cps and recognizes XON and XOFF ASCII characters as well.)

Please rush details. I understand this brush-up course on the latest in tape readers does not obligate me in any way.

Name _____ Position _____

Firm _____

Street _____

City _____ State _____ Zip _____

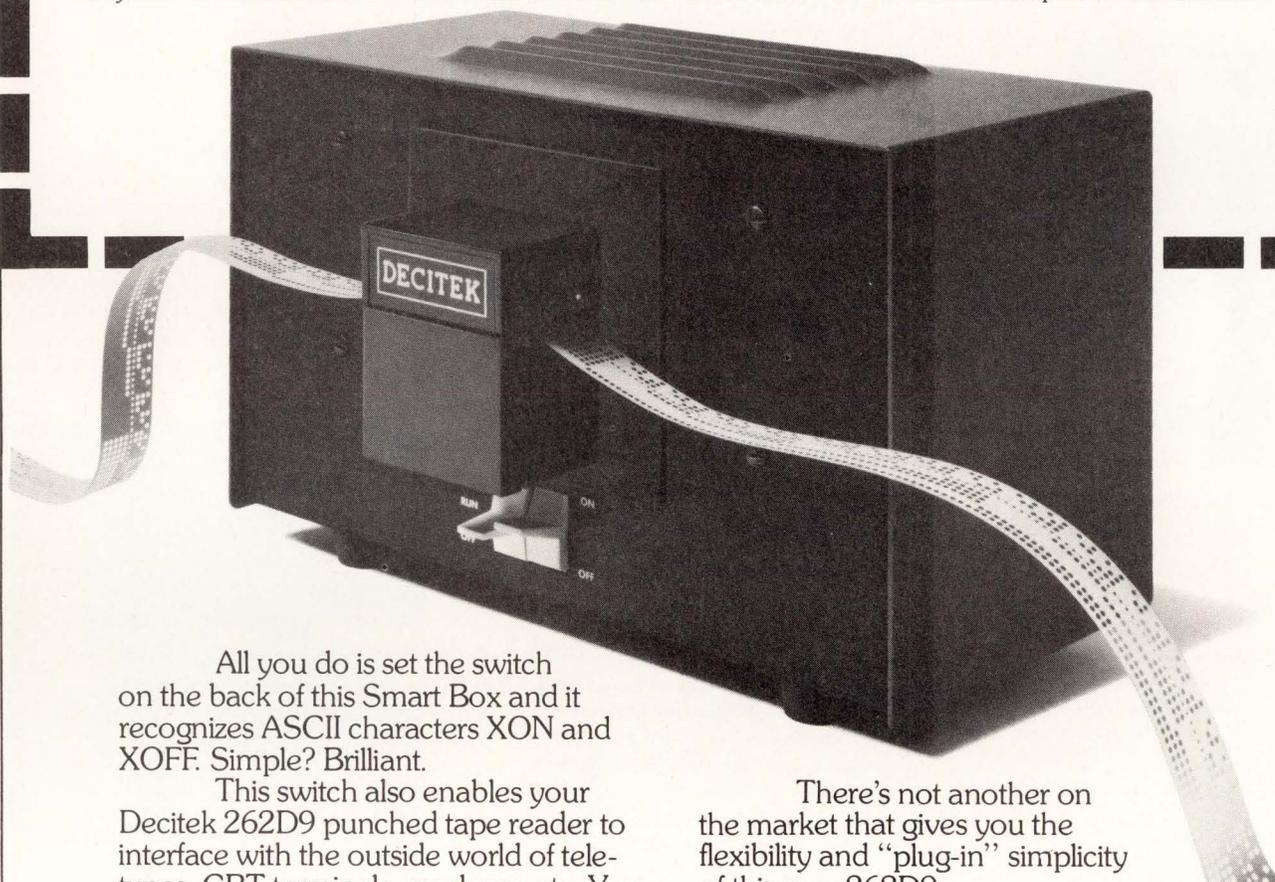

All you do is set the switch on the back of this Smart Box and it recognizes ASCII characters XON and XOFF. Simple? Brilliant.

This switch also enables your Decitek 262D9 punched tape reader to interface with the outside world of teletypes, CRT terminals, modems, etc. You select it, the Smart Box does it without internal programming by jumpers.

Then, using the second mode selector on the rear panel, you can program transmission rate (from 110 to 9600 baud), word length, parity and number of stop bits.

There's a lot more to this intelligent box. Dual-sprocket drive, 25,000 hour light source with fiber optics and stepper motor drive – that's a lot of tape reader. Add-on fan-fold boxes and 19" wing adapters provide installation versatility if you need it.

There's not another on the market that gives you the flexibility and "plug-in" simplicity of this new 262D9.

That's a fact. Another fact that will interest you is the reasonable cost of this improved Smart Box. So, do the smart thing. Mail the coupon for the FREE Speed Reading Course. Or, if you're in a hurry, call (617) 366-8334. Get the facts over the phone.

When reading matters

DECITEK

A Division of Jamesbury Corp.

129 Flanders Road, Westboro, Massachusetts 01581

NEW PRODUCTS

300LPM BAND PRINTER

Ranging in speed from 75-600 LPM's, Band Line 3000 Series contains four models which are more compact in size, and lower priced than DPC's ChainTrain[®] 200 Series of heavy duty computer line printers. Although capable of standing up to main computer room workloads, the 3000 Series is intended for smaller computers or remote print-out locations. Model 3300 features a speed of 300 LPM's, paper slew rate of 15 ips, 132 positional line length, 64 character set (48, 96, 128 optional) and ASCII print coding. Full-line buffered and μ P-controlled,



Model 3300 offers line spacing of 6 lpi and can accept 1 to 6 part forms (3"-17.5" width) and features a single line advance of 25 msec. Other features include: advanced horizontal font band-type printer featuring on-the-fly impact, backstrike, full formed characters, simple operator changeable type band and ribbon cassette. Physically, the beige and black unit stands 40", is 27" wide and 19" deep. **Data Printer Corp.**, 99 Middlesex St., Malden, MA 02148. (617) 321-2400. **Circle 143**

μ C DICTIONARY

This 322-pg. illustrated dictionary of μ C terminology by Michael Hordeski gives detailed explanations for nearly 4000 terms in μ Cs and related peripherals. Although not as bulky as Charles Sippl's dictionary, this listing is a convenient reference. No. 1088, \$7.95. **Tab Books**, Blue Ridge Summit, PA 17214. **Circle 135**

ELECTRONICS COOKBOOK

"303 Dynamic Electronic Circuits," a 308-pg. book (No. 1060) by Frank Tedeschi and Raymond McIntyre, is another circuits cookbook with schematics and circuit descriptions for each circuit. There are 13 chapters that cover everything from PLL and speech compressors to the usual pulse and digital circuits, oscillators, dc sources, regulators, meter and detector circuits, and analog computer and control

circuits, not to mention the ubiquitous 555-type circuits. Three chapters provide auto, game and music circuits. This book covers more analog circuits than digital, and although it seems we recognize some of these circuits from someplace or other, it's still worth the \$6.95 price for hobbyists, technicians and even associate engineers. **Tab Books**, Blue Ridge Summit, PA 17214. **Circle 137**

PDP-1170 4 MBYTE INTELLIGENT MEMORY

This 8-pg. brochure describes MSC's "Intelligent Memory" for DEC's PDP-11/70. The brochure explains how the memory, with its built in μ C, provides instant memory status without interfering with the computer's CPU. It also discusses error correction, memory expansion and installation. **Monolithic Systems Corp.**, 14 Iverness Dr. E., Englewood, CO 80112. (303) 770-7400. **Circle 141**

CALCULATOR ANALYSIS

With this 9-chapter book and a business programmable calculator like TI's MBA, engineers and engineering managers can master calculator analysis of marketing, forecasting, accounting for engineers, decision-making statistics, quantitative methods and much more. \$12.95. **Texas Instruments Electronics Series**, **McGraw-Hill Book Co.**, Suite 26-1, 1221 Ave. of the Americas, New York, NY 10020. **Circle 142**

COMPUTER FRONT-END SYSTEM

SAM X combines signal conditioning, amplification and multiplexing in a single dual-channel module. The cost-effectiveness, accuracy and performance makes it possible to use amplifier-per-channel front-ends for new applications where their performance has always been needed but costs were prohibitive. SAM-X processes digital and analog inputs and outputs and features: transducer excitation, system calibration, signal conditioning, amplification, multi-

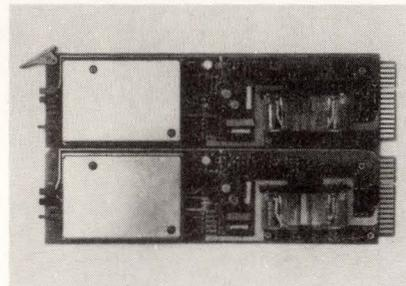

plexing, digitizing, offset correction, averaging, 20,000 SPS and hardware validation. Previous to SAM-X, all amplifier/channel computer front-ends achieved cost reductions only by sacrificing flexibility.

SAM-X offers full flexibility of selectable filter bandwidth and programmable gain. Filter bandwidths are selected by using a plug-in module, and amp gain is selected by using front-edge switches. SAM-X is easier to use by front-edge test points and built-in amp and bridge calibration circuitry. SAM-X modules offer 120dB CMR at 60 Hz, but at a price that compares favorably with limited fixed gain, fixed bandwidth units. **AVCO Electronics Div.**, 4807 Bradford Dr., Huntsville, AL 35805. **Circle 139**

VT52 EMULATION

Emulating the code structure and functions of DEC's VT52, MODEL VT52-COMPAT includes the large 15" non-glare screen, compact size and detachable keyboard. There is no repeat key, as all keys are typematic, and no control switches: all operating controls are set from the keyboard. The 35 lb. VT52-Compat measures 15"W x 14"H x 13.6"L, plus kB and utilizes Ann Arbor's "Smart Monitor." The unit displays 24 lines of 80 characters, U/L case; characters are formed in a 7x7 dot matrix in a 10x10 dot field. The cursor is a blinking field. VT52-

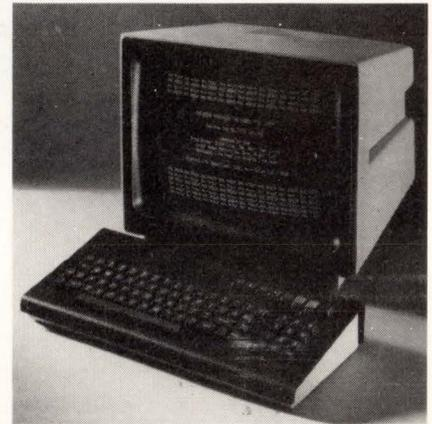

Compat includes an 81-key detachable kB which generates the full 128-character ASCII set. A separate numeric pad and cursor control keys are standard. Use of Shift, Control and Caps Lock keys are identical to the VT 52. Up to 28 additional special function keys are available. All command and control functions may be executed from the kB; commands are Erase screen, Erase to end of line, Cursor home/return/up/down/right and left, Line feed, Reverse line feed, Backspace, Tab, Set cursor position and Bell. Control functions are selection of baud rate (110 to 9600) and I/O mode (full or half-duplex). Available options include export power, current-loop interface, and rack-mounting panel and a variety of case options. \$1400. Delivery: 8 wks. ARO. **Ann Arbor Terminals, Inc.**, 6107 Jackson Rd., Ann Arbor, MI 48103. (313) 769-0926. **Circle 144**

NEW!

"INDUSTRIAL"

WIRE-WRAPPING
TOOL

MODEL BW928

\$49⁹⁵

BATTERIES NOT INCLUDED
BIT & SLEEVE NOT INCLUDED

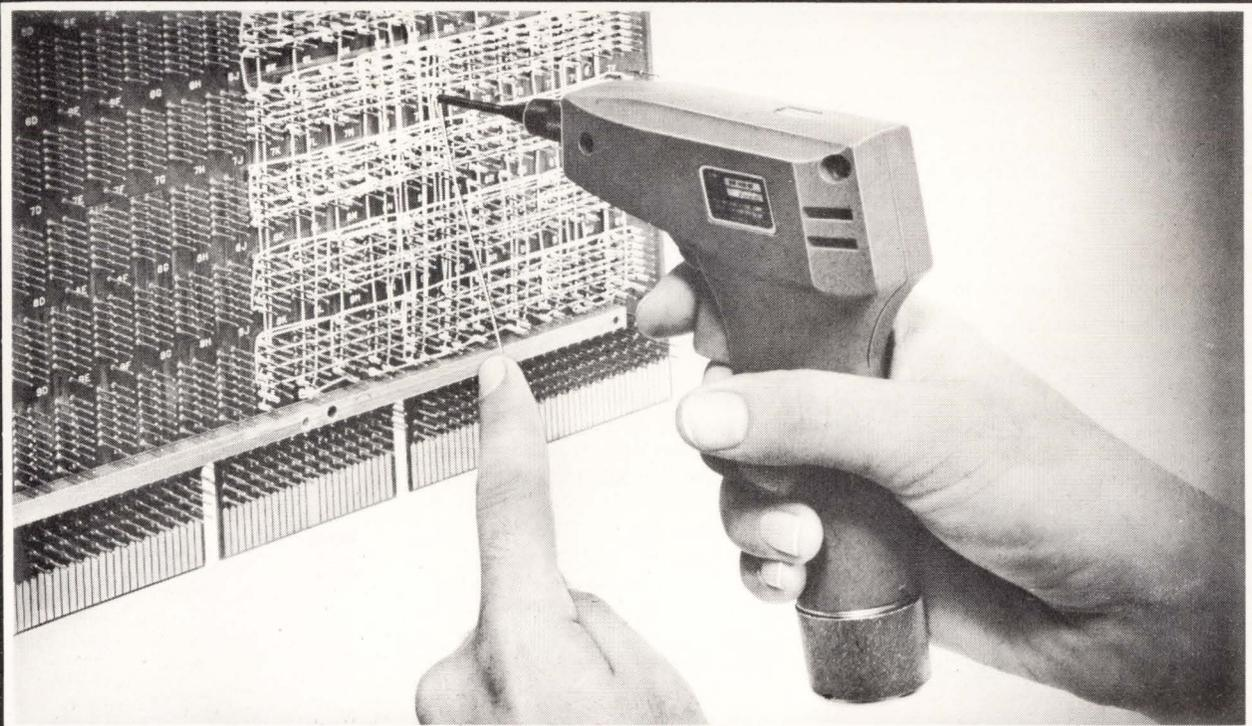

- BATTERY OPERATED
(2) Standard "C" Ni Cad Batteries (not included)
- INTERCHANGEABLE BITS & SLEEVES
(not included)
- REVERSIBLE ROTATION
For unwrapping, reverse batteries

- BACKFORCE OPTIONAL
Model BW928-BF \$52.95
- POSITIVE INDEXING
- LEIGHT WEIGHT
*LEXAN™ Housing

*LEXAN™ GENERAL ELECTRIC



OK MACHINE & TOOL CORPORATION

3455 Conner St., Bronx, N.Y. 10475 • (212) 994-6600 • TELEX 125091

NEW PRODUCTS

ASYNCHRONOUS LINE DRIVER

An asynchronous line driver (ALD) provides half- or full-duplex data transmission over two- or four-wire facilities of up to 14 miles. The ALD operates in point-to-point or multipoint/pollled modes, and is both speed- and code-transparent. The ALD is designed for

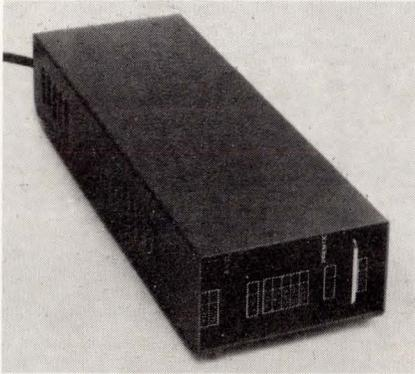

use on dial-up or leased short-haul circuits as a cost-effective alternative to more expensive modems intended for longer distances. For example, the ALD transmits at 4800 bps for up to six miles, and at 9600 bps for up to four miles, on a 26 AWG non-loaded cable. The ALD meets Bell specification #43401 and is a low-cost replacement for the Western Electric 103F, 202R and 202T modems, and for any other O-9600-bps asynchronous modem. \$280. **Prentice Corp.**, 795 San Antonio Rd., Palo Alto, CA 94303. **Circle 182**

I/O CARD TO S-100 COMPUTERS

The IF-1 I/O card interfaces an integrated circuit tester module to S-100 bus computers. While primarily intended as a dedicated interface, IF-1 can also be used as a general purpose I/O card in applications which require up to 16 output lines and 8 input lines.

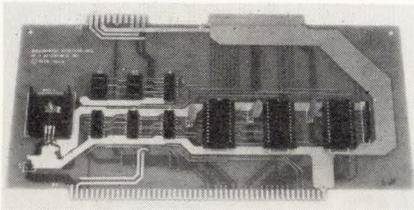

IF-1 provides two fully buffered 8 bit output ports and one fully buffered 8 bit input port. I/O address decoding is jumper selectable on any four port boundary in the system I/O address space. All 24 I/O lines are brought out to a single 50 pin mass terminated cable connector. **Pragmatic Designers, Inc.**, 711 Stierlin Rd., Mountain View, CA 94043. **Circle 180**

Z8 SOFTWARE DEVELOPMENT

The Z8 Software Development Package, an assembler and simulator package permits users to write and debug Z8 software without Z8 microcomputer hardware. The package will run on any Zilog MCZ or ZDS sys-

tem with 60 kbytes of memory. The PLZ/ASM assembler allows for generation of relocatable and absolute object code. High-level control and data structures in the language enable the user to balance structured programming practices with machine-dependent operations. Data structures include bytes, words, arrays and records. The Z8 simulator enables the user to set and display simulated memory, set breakpoints, and access simulated external memory. It handles ports, provides for code execution timing, logs its output, and has macro capability. \$950. **Zilog**, 10340 Bubb Rd., Cupertino, CA 95014. **Circle 183**

5.25" MINI DISK DRIVE

The BASF 6106 5.25-inch floppy disk drive, said to be smaller than any available drive, occupies the same vertical space as two Shugart SA-400's, providing a 33% increase in storage capacity per volume. The 6106 offers 40-track capacity, an increase over the industry standard of 35 tracks, and has a 12 msec track-to-track access time. (The industry standard is 40 msec.) The drive operates in both FM and MFM recording modes and provides up to 250,000 bytes of unformatted capacity on one side of a floppy disk. BASF 6106 is plug-compatible with Shugart's SA-400, with a front-plate covering the gap left by the smaller BASF

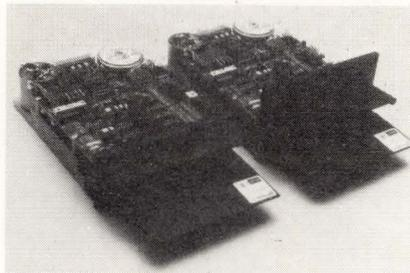

drive. A non-frictional ball race used for head positioning reduces wear and unreliability (a problem with the ball-in-a-groove-type head positioning). BASF 6106 offers a variety of systems-oriented options, such as software-controlled door interlock, head-loaded activity LED and a head-load control separate from the select control. A double-sided version is available in sample qty's. **Computer Products, BASF Systems, Crosby Dr.**, Bedford, MA 01730. **Circle 185**

DOUBLE DENSITY DISK

Considered a major breakthrough in disk technology, STC 8650 double density disk drive offers 635 Mbyte of data storage/spindle by doubling track density from the standard STC 8350 to the highest recording density ever achieved. In a typical installation, STC 8650 offers a cost/Mbyte reduction of 30%. STC 8650 is housed in the same physical dimensions as the earlier STC 8350, so users can satisfy immediate needs now with the STC 8350, with these units later field upgraded to double their capacity. **Storage Technology Corp.**, 2270 South 88th St., Louisville, CO 80027. (303) 497-5020. **Circle 146**

μC SYSTEM

A complete and inexpensive S100 Power Supply is now available from CGRS Microtech. This supply provides unregulated +8 V @ 10 A as well as +16, -16 V @ 1 A. The

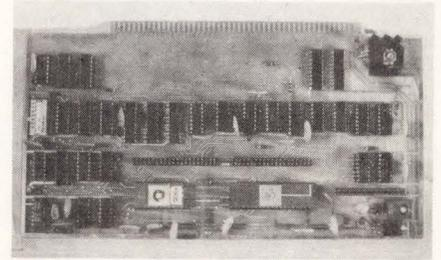

S100 Power Supply kit comes with special transformer, rectifiers, capacitors, mounting hardware and metal foundation. \$49.95. **CGRS Microtech**, Box 368, Southampton, PA 18966. (215) 757-0284. **Circle 189**

480 LPM THERMAL PRINTER

Printing at speeds up to 480 full lpm with high resolution (77 dots/in.) characters upon high contrast, fade resistant paper, the 9876A, is a stand-alone version of the built-in printer of the HP System 45 desktop computer. In addition to its two variable interfaces, 8 bit parallel and IEEE-488, the outer case of the printer is a removable shell which clamps over the internal print mechanism. The mechanism and power supply are available separately. Each character is composed of a 5x7 dot matrix of 300-micron square dots. Two row positions above and below each character allow for special marks or ascending and descending characters. The full HP 9876A character set contains 128 standard ASCII characters, both upper and lower case, and control characters. Seven additional character sets, which exist in the printer at all times, can be accessed through software. Graphics on the 9876A can be printed in two forms, strip chart and CRT dump. The graphics field is 560 dots within a plot 185-cm wide. Plotting speeds range from .38 to 2.5 cm/sec., or



about .15 to 1.0 in/sec. The HP 9876A uses a new fade-resistant black perforated paper in fan-fold configuration. Up to 330 pages of fan-fold thermal paper is stored on an internal tray. Three special features — a top and bottom margin command, and user-controllable line spacing — simplify arranging the print field upon the paper. \$3,500. **Hewlett-Packard, Co.**, 1507 Page Mill Rd., Palo Alto, CA 94304. **Circle 169**

MDS 2021/2022 CARTRIDGE TAPE DRIVE -a miniperipheral with big capabilities

We've shed light upon a 3M-compatible* cartridge tape drive that is in use by more OEM's than any other cartridge drive. It's simple to see why.

You'll find the flexibility you need for virtually any digital data handling requirement. Features like 30 ips read/write, 90 ips search and rewind, read-after-write checking, 800/1600 bpi. recording density, and phase or biphas encoding on 1, 2, or 4 tracks. Storage capacity per cartridge is up to 23 million bits. But there's more to this drive's wide acceptance than meets the eye. Features like interchangeable printed circuit boards, long-life motor, and initial

low cost have made this unit particularly suitable for small system integration where cost/performance, reliability and serviceability are of utmost concern.

Applications like remote data collection, data communications, word processing, POS, and data entry are just a few ways that these drives are handling data in thousands of systems today.

To get all the facts on the MDS 2021/2022 Cartridge Tape Drive, mail the attached coupon, or call us collect today.

*3M DC300A Data Cartridge



**Mohawk Data Sciences
OEM Division
Palisade Street,
Herkimer, N.Y. 13350**

East Coast-Contact: H. Johnson (315) 866-5300
West Coast-Contact: J. Engstrom (714) 772-0803

Please send me information on the MDS 2021/22 Cartridge Tape Drive.

Name _____

Title _____

Company _____

Street _____

City _____ State _____ Zip _____

I'm in a hurry. Have a representative call me at: (____) _____

DD279

NEW PRODUCTS

DIGITAL INTERFACING

"Digital Interfacing With an Analog World," a 406-pg. book by Joseph J. Carr, is a how-to book with minimal theory. It covers transducers, analog function modules and digital circuits, data transmission (including phone interfacing and readout/display devices), data conversion and digital codes. The biggest single portion covers digital data acquisition. No. 1070, \$8.95. **Tab Books**, Blue Ridge Summit, PA 17214.

Circle 136

GENERAL-PURPOSE PROCESSORS

The Series Sixteen 10/20/30 family, intended for OEMs and system builders in the business and industrial marketplaces, ranges from low-cost, entry level systems through high-performance, large memory systems. Processor features include signed multiply/divide, list processing, breakpoint, power fail/auto restart, serial I/O port and clock. Using 4K and 16K N-channel MOS RAMs, Series Sixteen processors can pack 64KB to 256KB of memory on a single 15" x 15" PC board. The Sixteen 10 processor supports memory to 64 KB and is expandable in either 8K or 32K increments; memory is available in 32 KB increments up to a 25 KB max. on either the Sixteen 20 or 30. Any packaged system containing a Sixteen 10 can be upgraded to a Sixteen 20

processor. The processors include several large machine features such as 16 general-purpose registers, comprehensive set of 161 basic instructions, dual bus architecture and 255 interrupt levels. Systems range from 32KB to 256KB of memory, 512KB floppy to 300MB disk storage, and a wide array of Perkin-Elmer peripherals such as terminals and printers. The 1615 system, (\$11.2K) aimed at small stand-alone applications or as a remote system tied to a central host in a distributed processing system, includes a Series Sixteen 10 processor with 32 KB of 900 nsec MOS memory, system control panel, cabinet and 8-slot chassis, 50 supply, Model 550 video display unit, Model 655 page printer, memory processor integrity test, OS/16 auto load, AC line frequency derived clock, and 512KB of floppy storage. The 1624 system (\$17.7K) includes the Series Sixteen 20 processor with 64 KB of 900 nsec parity MOS memory and includes all features of the 1610 system plus memory expansion to 256KB and a CP120 matrix printer. Aimed at multiterminal system applications, the 1625 system (\$24.25K) features a processor with 64 KB, expandable to 256 KB of parity memory, a Model 550 video display unit, 10 MB of disk storage and a CP120 matrix printer. The 1635 system (\$29.50K), intended for multiterminal applications where high performance and data integrity are paramount, includes a Series Sixteen 30 with 126 KB of 750 nsec MOS memory with ECC,

16-slot chassis and cabinet, 50 Ap supply, system control panel and terminal, OS/16 auto load and object code, line frequency derived clock, floppy disc interface and 10 MB disk. The 1635 system includes a 550 video display unit, CP180 matrix printer and interface, high-performance fixed point signed multiply/divide, power fail/auto restart with 6 min. battery back-up. Optional floating point processors are available for the 1625 and 1635 systems. **Perkin-Elmer Corp.**, Interdata Div., 2 Crescent Pl., Oceanport, NJ 07757. (201) 229-6800. **Circle 138**

12 / 20 CHARACTER THERMAL PRINTERS

Two thermal line printer assemblies, the EPN9112 and EPN9120, offering 12 and 20 character full-alphanumeric capabilities. Both assemblies print lines of five dots for each character and a stepping motor advances the paper to form seven dots per column resulting in a 5 by 7 dot-matrix for each character. The low peak-power requirements of both printers make them suitable for battery powered applications. The thermal print mechanism utilizes beam-lead semiconductor technology. Electrical connections and blocking diodes are built into the printhead device to permit electrical strobing, thereby reducing the number of required external connections and minimizing peak power consumption. 12-character model, \$33.62; 20-character, \$46.75. (100) **Texas Instruments Inc.**, P. O. Box 225012, M/S 308, Dallas, TX 75265. **Circle 192**

Memodyne Introduces Two New Ways To Expand the Capabilities of Your Texas Instruments Inc. Silent 700* Terminal

WRITE ONLY RS232C OR PARALLEL DIGITAL CASSETTE RECORDER

MODEL 2146

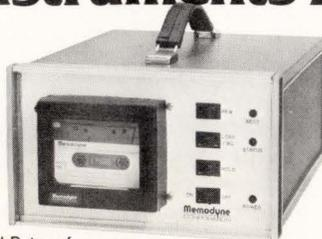

- Records RS232C data @ Baud Rates of 110, 150, 300, 600, 1200
- Records Teletype data (20 MIL loop)
- Records Parallel, ASCII data up to 120 characters/sec.
- Fully TTL Compatible
- Formats data for playback on TI Silent 700* terminals.

The Memodyne Model 2146 records digital data on standard Philips cassettes. As a stand alone instrument it is ideal for constantly monitoring and recording the outputs from blood counters, nuclear counters, chromatographs, spectrometers and other laboratory and industrial apparatus for later analysis on a Silent 700* terminal.

The Model 2146 offers three major advantages.

1. Permits data gathering at remote sites and times not conveniently accessible to the terminal.
2. Prevents the terminal from being tied up collecting data.
3. Allows a much faster and easier entry method to the computer than a keyboard. An OEM version, Model 146 is also available.

*Trademark of Texas Instruments, Inc.

For more information on these instruments please call or write:

Memodyne
CORPORATION

(617) 444-7000, TELEX 922537
220 RESERVOIR ST.
NEEDHAM HGTS, MA 02194

READ/WRITE RS232C OR PARALLEL DIGITAL CASSETTE RECORDING SYSTEM

MODEL 3765-8BV



- Records RS232C data @ Baud Rates up to 4800
- Records Parallel data @ rates up to 500 characters/sec.
- Formats data for playback on TI Silent 700* terminals
- Reads tapes written on TI Silent 700* terminals.
- Compatible with several other Memodyne recorders.

The Model 3765-8BV records digital data on Philips cassettes but also reads and transmits this data either in parallel or RS232C Serial formats. Since the data is written on the tape in a format compatible with the TI Silent 700* terminal, tapes may be played back at a later date on these terminals. The 3765-8BV will also read tapes written on the Silent 700* terminals and transmit the data out at high speeds.

The 3765-8BV is a complete system with manual, logic or coded controls for tape movement and data entry and removal making it extremely useful as a peripheral to a mini or micro computer as well as an off-line recording instrument.

Circle 54 on Reader Inquiry Card

THE BEST 300 LPM PRINTER ON THE MARKET IS NOW EVEN BETTER.

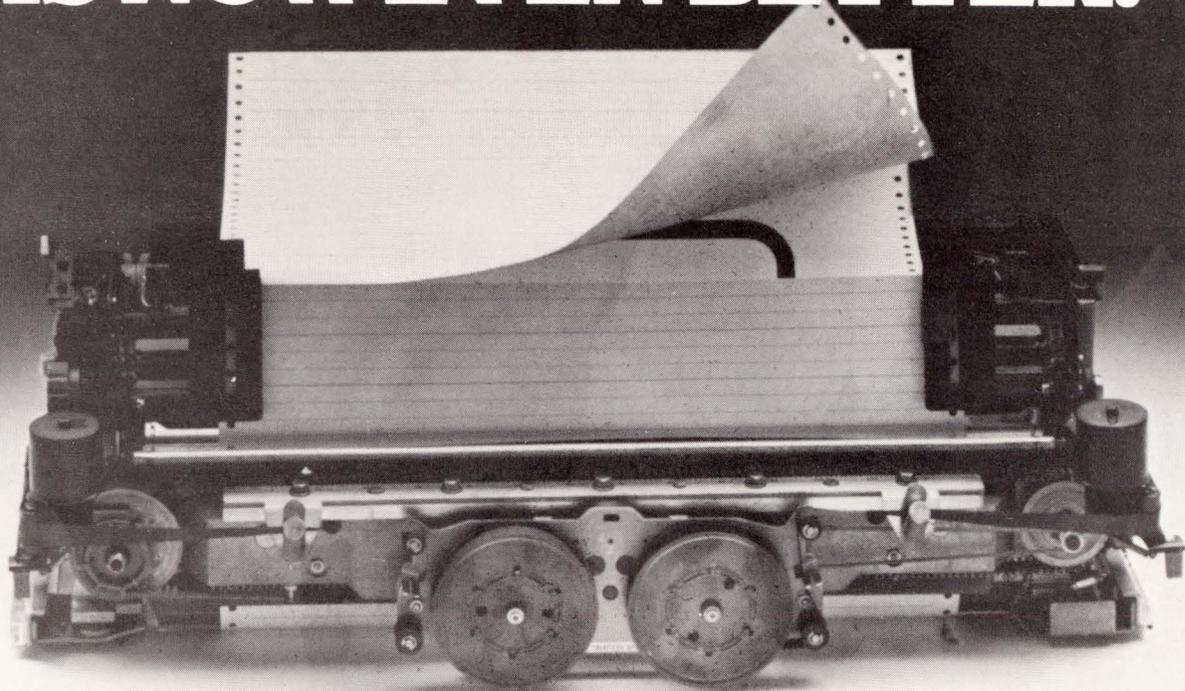

In order to build up a customer base of more than 40,000 units in three years, you have to have a superior printer. And no matter how you look at it, the Teletype* model 40 printer has a lot going for it.

Look at cost. Nowhere does anyone offer as much in a 300 LPM printer for as little as the model 40 costs. At the OEM price of under \$2000, it even compares favorably against low-speed printer costs.

Look at reliability. The model 40's unique design utilizes a minimum of moving parts for a maximum of on-line time. Plus proven LSI (Large Scale Integration) circuitry handles many functions formerly performed mechanically. This reduces hardware requirements and increases printer life.

Look at features. The unit is completely operational to give you everything necessary to go on-line. You also get 32 switch-selectable no-cost options to choose from, easily changeable character sets, and self-diagnostics.

Finally, look at product support. Not only do we offer nationwide service, we'll maintain your printer for as little as \$23 per month—and that includes labor and material.

With all that going for the model 40, how could we make it even better? Two ways.

First, we gave it a new, simplified OEM interface. Simply command the motor on, watch for the next character command, and send data.

Next, ribbon life has been significantly extended with our new re-inker mechanism that's available as a low-cost option.

No wonder we're getting a reputation as the OEM printer people.



THE OEM PRINTER PEOPLE

*Teletype is a trademark and service mark of the Teletype Corporation.

Talk about 'best sellers'!

This is the one new book that every discriminating design engineer and buyer should read.

A 40 page review of more than 200 models and their easy availability through more than 150 locations in the United States and Europe!

Today's Blue Book of quality and value in standard power supplies!

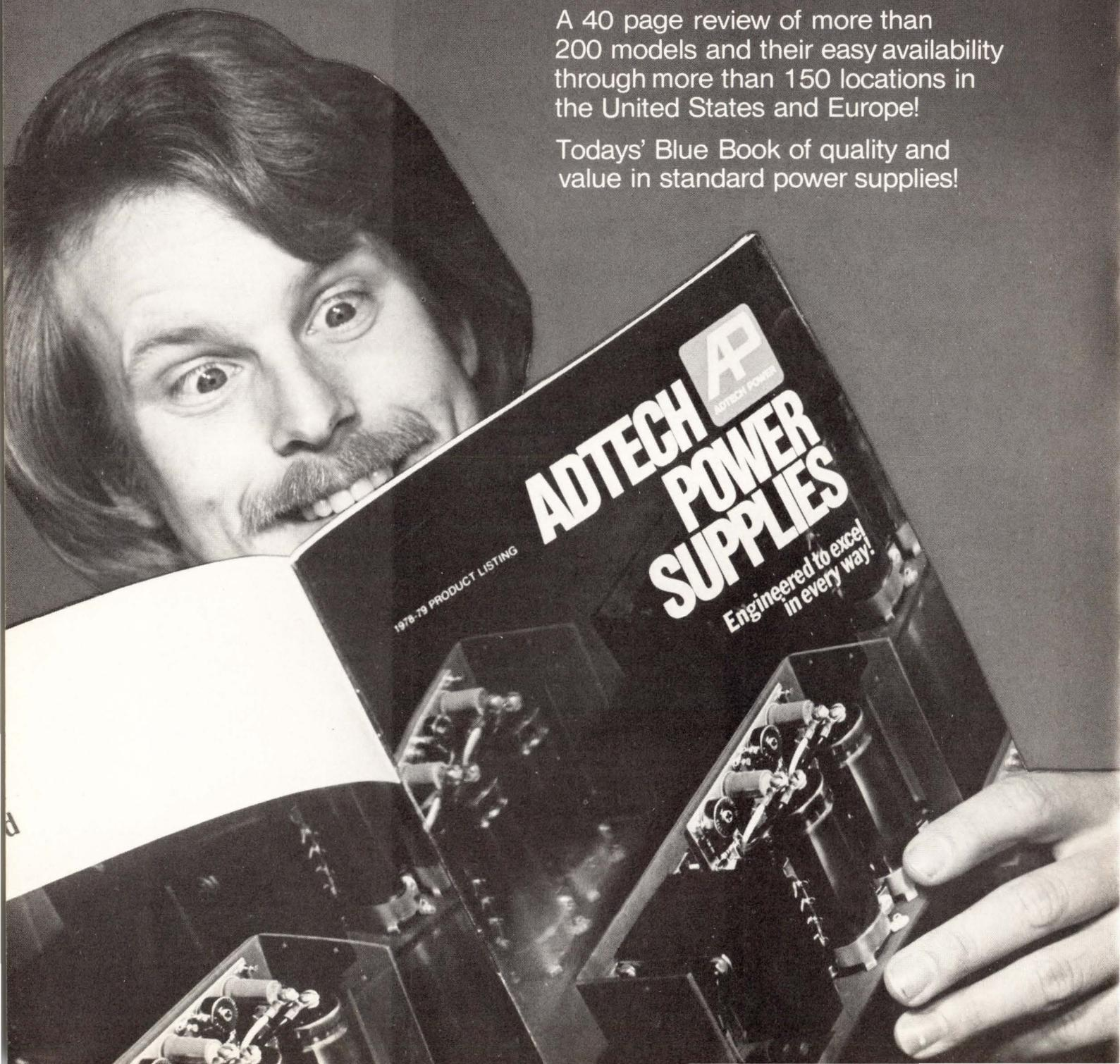

Get your copy today!

Just call the Adtech Distributor nearest you and get acquainted.

If you prefer, just send the postpaid reply card just above the reader service card of this publication.

Alabama, Birmingham
Newark Electronics
Phone: (205) 942-4044

Arizona, Phoenix
Cramer/Arizona
Phone: (602) 267-7321

Arizona, Tempe
Newark Electronics
Phone: (602) 968-7441

Arizona, Tucson
Ancrona
Phone: (602) 881-2348

California, Culver City
Ancrona
Phone: (213) 390-3595

California, Foster City
Newark Electronics
Phone: (415) 345-4892

California, Garden Grove
Allied Electronics
Phone: (714) 554-0731

California, Goleta
RPS
Phone: (805) 964-4764

California, Inglewood
Newark Electronics
Phone: (213) 678-0441

California, Long Beach
CTI Data Systems
Phone: (213) 426-7375

California, Los Angeles
RPS
Phone: (213) 748-1271

California, Oakland
Newark Electronics
Phone: (415) 632-7522

California, Orange
Newark Electronics
Phone: (714) 997-9572

California, Palo Alto
Zack Electronics
Phone: (415) 326-5432

California, Sacramento
Newark Electronics
Phone: (916) 920-3774

California, San Diego
Cramer/San Diego
Phone: (714) 565-1881

California, San Diego
Newark Electronics
Phone: (714) 481-1251

California, San Diego
RPS
Phone: (714) 292-5611

California, San Francisco
Zack Electronics
Phone: (415) 626-1444

California, Santa Ana
Ancrona
Phone: (714) 547-8424

California, Santa Clara
Allied Electronics
Phone: (408) 985-2323

California, Sunnyvale
Ancrona Corp.
Phone: (408) 243-4121

California, Sunnyvale
Cramer/San Francisco
Phone: (408) 739-3011

Colorado, Arvada
Newark Electronics
Phone: (303) 423-7941

Colorado, Denver
Cramer/Denver
Phone: (303) 758-2100

Colorado, Denver
Electronic Parts
Phone: (303) 744-1992

Colorado, Denver
Newark Electronics
Phone: (303) 757-3351

Connecticut, Bloomfield
Newark Electronics
Phone: (203) 243-1731

Connecticut, North Haven
Cramer/Connecticut
Phone: (203) 239-5641

Florida, Dania
Summit Electronics
Phone: (305) 920-6253

Florida, Fort Lauderdale
Newark Electronics
Phone: (305) 587-2372

Florida, Hollywood
Cramer/Hollywood
Phone: (305) 923-8181

Florida, Orlando
Cramer/Orlando
Phone: (305) 894-1511

Florida, Tampa
Newark Electronics
Phone: (813) 879-7700

Georgia, Atlanta
Ancrona
Phone: (404) 261-7100

Georgia, Atlanta
Newark Electronics
Phone: (404) 321-0413

Georgia, Norcross
Cramer/Atlanta
Phone: (404) 448-9050

Idaho, Boise
Newark Electronics
Phone: (208) 342-4311

Illinois, Chicago
Newark Electronics
Phone: (312) 638-4411

Illinois, Elgin
Allied Electronics
Phone: (312) 697-8200

Illinois, Hickory Hills
Newark Electronics
Phone: (312) 430-3232

Illinois, Mt. Prospect
Cramer/Chicago
Phone: (517) 799-8230

Illinois, Park Ridge
Newark Electronics
Phone: (312) 298-9550

Illinois, Rockford
Mid-West Associated
Phone: (815) 962-8036

Illinois, Rockford
Newark Electronics
Phone: (815) 229-0225

Illinois, Springfield
Newark Electronics
Phone: (217) 787-9972

Indiana, Indianapolis
Newark Electronics
Phone: (317) 298-7070

Indiana, Merrillville
Newark Electronics
Phone: (219) 738-2787

Iowa, Cedar Rapids
Newark Electronics
Phone: (319) 362-1171

Kansas, Lenexa
Newark Electronics
Phone: (913) 492-6000

Kentucky, Louisville
Newark Electronics
Phone: (502) 423-0280

Louisiana, Alexandria
Ralph's of Lafayette
Phone: (318) 443-4517

Louisiana, Baton Rouge
Ralph's of Lafayette
Phone: (504) 344-3761

Louisiana, Lafayette
Ralph's of Lafayette
Phone: (201) 785-0105

Louisiana, Lake Charles
Ralph's of Lafayette
Phone: (318) 439-2493

Louisiana, Metairie
Newark Electronics
Phone: (504) 888-5174

Louisiana, Morgan City
Ralph's of Lafayette
Phone: (504) 384-9831

Louisiana, New Iberia
Ralph's of Lafayette
Phone: (318) 369-9816

Maryland, Beltsville
Newark Electronics
Phone: (301) 937-5085

Maryland, Ellicott City
Newark Electronics
Phone: (301) 461-2300

Maryland, Gaithersburg
Cramer/Washington
Phone: (301) 948-0110

Maryland, Landover
Allied Electronics
Phone: (301) 773-5050

Massachusetts, Methuen
Newark Electronics
Phone: (617) 688-1837

Massachusetts, Newton
Cramer/Newton
Phone: (617) 964-4000

Massachusetts, Wilmington
Allied Electronics
Phone: (617) 942-0150

Massachusetts, Woburn
Newark Electronics
Phone: (617) 935-8350

Michigan, Grand Rapids
Newark Electronics
Phone: (616) 241-6681

Michigan, Oak Park
Newark Electronics
Phone: (313) 967-0600

Michigan, Royal Oak
George Instruments
Phone: (313) 576-4700

Michigan, Saginaw
Newark Electronics
Phone: (517) 799-0480

Minnesota, Edina
Cramer/Bonn
Phone: (612) 835-7811

Minnesota, Minneapolis
Harry Stark's
Phone: (612) 332-1325

Minnesota, Minneapolis
Newark Electronics
Phone: (612) 331-6350

Minnesota, St. Paul
Newark Electronics
Phone: (612) 631-2683

Mississippi, Pascagoula
Ralph's of Lafayette
Phone: (601) 769-1672

Missouri, Hazelwood
Newark Electronics
Phone: (214) 731-1204

Missouri, St. Louis
Olive Industrial Electronics
Phone: (314) 426-4500

Nebraska, Omaha
Newark Electronics
Phone: (402) 392-1221

New Jersey, Cherry Hill
Cramer/Pennsylvania
Phone: (609) 424-5993

New Jersey, Edison
Newark Electronics
Phone: (201) 272-2103

New Jersey, Kenilworth
Newark Electronics
Phone: (201) 272-8410

New Jersey, Little Falls
Cramer/New Jersey
Phone: (201) 785-4300

New Jersey, Moonachie
Cramer/New Jersey
Phone: (201) 935-5600

New Jersey, Pennsauken
Newark Electronics
Phone: (609) 663-9490

New Mexico, Albuquerque
Cramer/New Mexico
Phone: (505) 243-4566

New York, Buffalo
Summit Distributors
Phone: (716) 884-3450

New York, Hauppauge
Cramer/Long Island
Phone: (516) 231-5600

New York, Mineola
Allied Electronics
Phone: (516) 248-2360

New York, Plainview
GLD Electronics
Phone: (516) 694-8200

New York, Rochester
Cramer/Rochester
Phone: (716) 275-0300

New York, Rochester
Newark Electronics
Phone: (716) 473-6600

New York, Rochester
Summit Distributors
Phone: (716) 334-8110

New York, Snyder
Newark Electronics
Phone: (716) 839-5460

New York, Syracuse
Cramer/Syracuse
Phone: (315) 437-6671

New York, Valley Stream
Newark Electronics
Phone: (516) 561-7720

North Carolina, Greensboro
Pioneer/Carolina
Phone: (919) 273-4441

North Carolina, Greensboro
Newark Electronics
Phone: (919) 292-7240

North Carolina, Raleigh
Allied Electronics
Phone: (919) 821-0415

North Carolina, Winston-Salem
Cramer/Winston-Salem
Phone: (919) 725-8711

Ohio, Cincinnati
Newark Electronics
Phone: (513) 771-9700

Ohio, Cleveland
Cramer/Cleveland
Phone: (216) 248-8400

Ohio, Cleveland
Newark Electronics
Phone: (216) 361-4700

Ohio, Toledo
Newark Electronics
Phone: (419) 866-0404

Ohio, Willoughby
Allied Electronics
Phone: (216) 951-0908

Oklahoma, Oklahoma City
Newark Electronics
Phone: (405) 682-4418

Oklahoma, Tulsa
Component Specialties
Phone: (918) 664-2820

Oklahoma, Tulsa
Newark Electronics
Phone: (918) 622-5833

Oregon, Portland
Ancrona
Phone: (503) 254-5541

Oregon, Portland
Newark Electronics
Phone: (503) 620-1614

Pennsylvania, Allentown
Newark Electronics
Phone: (215) 434-7171

Pennsylvania, Horsham
Pioneer/Pennsylvania
Phone: (215) 674-4000

Pennsylvania, Philadelphia
Philadelphia Electronics
Phone: (215) 568-7400

Pennsylvania, Pittsburgh
Newark Electronics
Phone: (412) 787-7740

Rhode Island, Warwick
Newark Electronics
Phone: (401) 738-4010

South Carolina, Greenville
Newark Electronics
Phone: (803) 288-9610

Tennessee, Knoxville
Newark Electronics
Phone: (615) 588-6493

Tennessee, Memphis
Newark Electronics
Phone: (901) 365-8060

Texas, Austin
Component Specialties
Phone: (512) 459-3307

Texas, Austin
Newark Electronics
Phone: (512) 459-3163

Texas, Beaumont
Ralph's of Lafayette
Phone: (713) 833-9443

Texas, Corpus Christi
Newark Electronics
Phone: (512) 855-3971

Texas, Dallas
Component Specialties
Phone: (214) 357-6511

Texas, Dallas
Cramer/Texas
Phone: (214) 661-9300

Texas, El Paso
Newark Electronics
Phone: (915) 533-2486

Texas, Fort Worth
Allied Electronics
Phone: (817) 336-5401

Texas, Garland
Newark Electronics
Phone: (214) 494-5911

Texas, Houston
Allied Electronics
Phone: (713) 932-7321

Texas, Houston
Ancrona
Phone: (713) 529-3489

Texas, Houston
Component Specialties
Phone: (713) 771-7273

Texas, Houston
Newark Electronics
Phone: (713) 782-4800

Texas, Houston
Ralph's of Lafayette
Phone: (713) 641-0267

Texas, Pasadena
Newark Electronics
Phone: (713) 477-0286

Texas, Port Arthur
Newark Electronics
Phone: (713) 722-9306

Utah, Salt Lake City
Newark Electronics
Phone: (801) 486-1048

Washington, Bellevue
Newark Electronics
Phone: (206) 641-9800

Washington, Tukwila
Cramer/Seattle
Phone: (206) 575-0907

Wisconsin, Brookfield
Newark Electronics
Phone: (414) 781-2450

Wisconsin, Green Bay
Newark Electronics
Phone: (414) 494-1400

Wisconsin, Madison
Newark Electronics
Phone: (608) 221-4738

Wisconsin, Milwaukee
Parts Mart
Phone: (414) 276-1212

Wisconsin, Milwaukee
Allied Electronics
Phone: (414) 463-2662

Virginia, Richmond
Newark Electronics
Phone: (804) 283-5671

Canada, Downsview, Ontario
Cramer/Canada
Phone: (416) 661-9222

IN EUROPE

FRANCE

Omnitech

Paris (1) 257-62-80
Paris (1) 874-18-88

Texas Instruments

Le Plessis Robinson
(1) 630-23-43
Grenoble (76) 90-45-74
Toulouse (61) 21-30-32
Rennes (99) 79-54-81
Nice (93) 20-01-01
Toulon (94) 94-85-11
Strasbourg (88) 22-04-07

GERMANY

Neumuller GMBH

Taufkirchen-Munich
089-6118-1
Berlin 030/247212
Dusseldorf 0211/490325
Kornwestheim 07154/23330

Texas Instruments

Freising 08161/801
Munich 089/325011
Stuttgart 0711/547001
Frankfurt-Griesheim
0611/399061
Essen 0201/233551
Hannover 0511/648021
Berlin 030/8927063
Hamburg 040/2296478

BENELUX

De Buizerd Elec. BV

The Hague 070-469509

ITALY

Dott. Ing. G. de Mico S.P.A.

Bologna (051) 556614
Banchetta (Ivrea)
(0125) 422300
Padua (041) 652909
Rome (06) 316204
Turin (011) 874137
Milan (02) 653131

SCANDINAVIA

E.V.J.

Copenhagen (01) 839022

Electro Power

Oslo, Norway (02) 463253

Noack AB

Stockholm (08) 670820

SWITZERLAND

Seyffer Co. A.G.

Zurich 01/628200

UNITED KINGDOM

Texas Instruments Ltd.

London, Slough 33411
Southampton 0703-27267
Bedford 0234-67466
Stockport 061-432-0645
Edinburgh 031-229-1481

BELGIUM

J. P. Lemaire

Bruxelles 1020 Brussel
478-48-47

ADTECH POWER

DISTRIBUTOR PRODUCTS GROUP

ADTECH POWER, INC., 1621 S. SINCLAIR ST., ANAHEIM, CA 92806 (714) 634-9211 TELEX 68-1498

ADTECH INTERNATIONAL, Subsidiary of Adtech Power, 46 BD, Roger Salengro, 78200 Mantes La Ville, France. Tel. 4775301+

Circle 41 on Reader Inquiry Card



NEW PRODUCTS

RESIDENT CRT EDITOR FOR μ C

The Resident CRT Editor, M6800EDIT-ORM allows the M6800 EXORciser or EXORterm to create and modify source programs. The editor is designed specifically for use with the EXORterm 200 and 220 development systems, or in an EXORterm 150/EXORciser system. Each of these systems provides the means of monitoring, controlling and debugging user-defined machine operations, as well as providing the basic control and interface function of a micro-computer system. Source programs can be loaded into system memory from the keyboard, optionally listed with identifying line numbers on the CRT screen and/or line printer, and modified with edit commands from the keyboard. A text editing feature of the resident CRT editor is its ability to search through a source program and point to a specific character, or group (string) of characters, as well as entire lines or groups of lines. \$300. **Motorola Microsystems, P.O. Box 20912, Phoenix, AZ 85036. Circle 166**

DIGITIZER KIT

Consisting of two PC boards, components, pen-like stylus and working surface, this entire 15 x 15 x 1 in unit, when completely assembled, supports an 11 x 11 in active digitizing area. The digitizer specifies 200 lpi resolution and outputs 100 coordinate

pairs/sec. Point and continuous operating modes are switch-selectable, and the unit never requires any alignment/calibration. Typical applications include interactive graphics, cartography, CAD, mathematical analysis, games, menu data entry and CRT cursor control. Standard output is 16-bit parallel binary; RS-232 or Apple-II interface is optional. \$449. **Talos Systems, Inc., 7419 East Helm Drive, Scottsdale, AZ 85260. (602) 948-6540. Circle 163**

EPROM COPIER

Model 7818, a stand alone EPROM copier for production line applications, is designed with low-cost personality plugs. The EPROM copier can duplicate a wide variety of

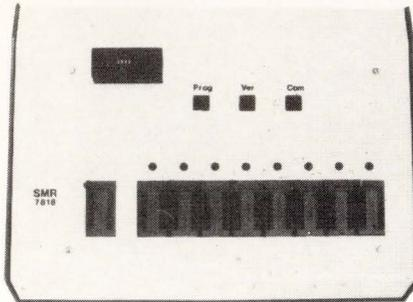

EPROMs including 2704, 2708, 2758, 2716-3, 2716-1, 2732, and 2532. Model 7818 copies both three-supply and single-supply type EPROMs. Model 7818 EPROM copier can program from 1 to 8 duplicate EPROMs

at once. \$1325; personally plugs, \$40 ea. **SMR Electronics, 3 Haven Rd., Medfield, MA 02052. (617) 359-7696. Circle 164**

μ C/SUPPORT DEVICE BOOKS

Replacing the bound Vol. 2 in the Osborne series, "An Introduction to Microcomputers - Volume 2," now comes in looseleaf form in a binder, with new updates published in six monthly updates between Sept. 1978-1979. Volume 3, "Some Real Support Devices," describes support devices like ROMs, PROMs, EPROMs, EAROMs, static and dynamic RAMs, parallel I/O devices (simple and programmable I/O ports), UARTs, USARTs, data converters and peripheral controllers. Vol. 2, \$25; Vol 3, \$15 (w/o binders); Vol 2 and 3 with subscription to six issues of each series, \$40; Vol 2 or 3 updates only, \$25. **Osborne & Assoc., Inc., Box 2036, Berkeley, CA 94702. Circle 187**

COLOR RASTER DISPLAY

This high resolution digital video processor utilizes a compressed data representation of pictures called run length encoding, which permits real time animation display at low cost. Run length encoding, where adjacent points having the same color are compressed to a single datum, can achieve compression ratios of 30:1 for typical computer generated pictures. This reduction in the number of bits required to describe a picture allows an entire image to be updated from a computer disk fast enough to support 15 frame per second animation. Double buffering of pictures allows changes to the image without seeing incomplete or partial updates. The CVD/2 features 640 x 480 resolution with 64 colors selectable from a 32,768 color palette. Character generation hardware features high quality, software defined fonts, with variable width and drop shadow. Video output is RGB, RS-170 compatible for direct connection to standard TV monitors and large screen video projectors. NTSC encoders are available. CVD/2 with 16KW Double Ported Refresh Memory and PDP-11 interface, \$14k. **3 Rivers Computer Corp., Box 235, Schenley Park, Pittsburgh, PA 15213. Circle 161**

HIGHSPEED S2114

The S2114H highspeed version of the S2114 static RAM has a maximum access time of 70 nsec. The device is intended for high-speed cache and buffer memory applications that need higher speeds than standard parts can supply. The 1K x 4 organization and single power supply requirement make it good for use in these highspeed systems.

The fully static S2114H RAM is a 4K VMOS device designed to operate from a single +5 Vdc power supply. It is TTL compatible on all inputs and outputs and requires no clocks or refresh cycles. The chip select function facilitates memory expansion by allowing the input/output pins to be OR-tied to other devices. **American Microsystems, Inc., 3800 Homestead Road, Santa Clara, CA 95051. Circle 202**

By anyone's measure

The industry standard

Raymond's Model 6406 Raycorder has long been the standard by which other digital cassette recorders are measured. It's now available with new, easier to use interface electronics, including an 8-bit parallel interface compatible with the popular microprocessors, at new lower prices.

For complete information contact:

Raycorder Products Division
Raymond Engineering Inc.
217 Smith Street, Middletown, Connecticut 06457 (203) 632-1000
a subsidiary of Raymond Industries

Circle 42 on Reader Inquiry Card

S-100 VIDEO DIGITIZER

The CAT-100/C, an integrated, expandable, general-purpose video imaging system for the S-100 bus consists of two standard-size S-100 boards. It accepts standard monochrome TV signals as input with a variety of synchronization choices: the automatic composite sync extractor will operate on RS-170, RS-330, or random interlace sync. Two selectable A/D conversion circuits provide a choice of 1, 2 or 4 bits per pixel at maximum video rate, and a complete video frame can be digitized in 1/60 of a second. Thirty different graphic formats are selectable by software for digitization as well as for display, and resolutions range from 256 to 1280 pixels per TV line. Typical formats include 240 lines of 256 pixels of 4 bits, and 480 lines of 512 single-bit pixels. The on-board 32K-byte graphic/alphanumeric buffer is fully accessible for image generation or processing in the address space of the S-100 bus through an adjustable window which can be made as small as 2K bytes. The buffered image can be generated either by the built-in video digitizing circuitry or by the S-100 probe displayed in 16 shades of gray or 16 colors on standard video monitors. The CAT-100/C also provides an excellent tool for text editing. Six different formats are available in a text mode as an alternative to the graphics mode. The character generator uses a high-definition 7 x 9 matrix. Maximum text density is 34 lines of 80 characters per screen. A smooth scrolling feature allows to scan the entire 32K-character buffer with variable speed. **Digital Graphic Systems**, 595 Mataro Ave., Palo Alto, CA 94306. **Circle 165**

MINIATURIZED UPS POWER SUPPLY

Conduction cooled Series NHX uninterruptible dual input/multiple output miniaturized supplies provide dual-isolated inputs that can be externally switched in event of primary power loss. Their multiple output regulators function with either input voltage, avoiding hardware duplication. INPUT Capability (user selects any two): 115VAC (47-500Hz), 12VDC, 28VDC, 48VDC or 115VDC. OUTPUT Capability (user selects up to 8 isolated outputs): 3 to 300VDC with up to 300 W total output power. They

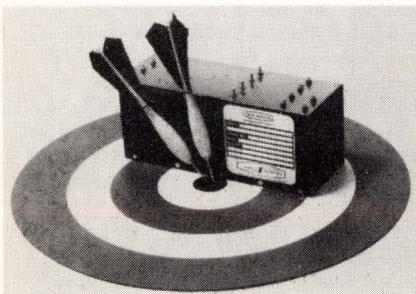

provide efficiencies to 80%, short circuit protection, line and load regulation to 0.1% and operating temperature range from -10 to +71°C. Customers can choose from a wide range of catalog input and output sub-modules to meet specific requirements. There are no long lead times nor engineering charges. Over 1500 possible configurations

exist and every supply is potted and burn-in tested before delivery. **Arnold Magnetics Corp.**, 11520 W. Jefferson Blvd., Culver City, CA 90230. (213) 870-7014. **Circle 148**

DUAL-HEAD DISKETTE DRIVE

Remex RFD 4000, an IBM media compatible, flexible disk drive incorporating a test-proven dual-head design, features band drive positioning, thus improving data track significantly over traditional lead screw systems. RFD 4000 is media compatible with the single-sided IBM 33FD and two-sided IBM 43FD single- and double-density

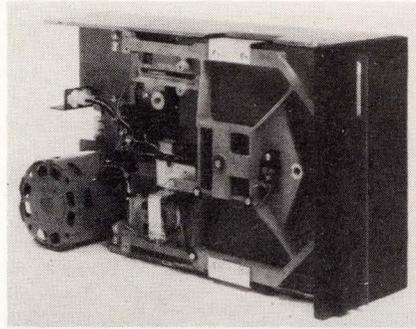

drives. It stores up to 1.6 Mbytes of unformatted data, 1 Mbyte in IBM 128 byte sector format. The dual head drive's access time is 3 msec track-to-track, providing an average seek of only 91 msec (including settle). The dual head and carriage assembly provides for two ceramic R/W heads with tunnel erase structures to be carried on a lightweight head carriage. The bottom head is fixed in the head carriage; the top, mounted on a movable head load arm attached to the carriage. Due to significant head carriage and electronics improvements (over other dual head drives), RFD 4000 provides high reliability, extended media life and high data integrity. It has physical and electrical interface compatibility with Shugart's SA850/851. \$740. **Remex Div., Ex-Cell-O Corp.**, Box C-19533, 1733 Alton St., Irvine, CA 92713. (714) 557-6860. **Circle 140**

MATRIX PRINTER/PLOTTER

Software- and plug-compatible with Versatec electrostatic printer/plotters, the T-1100A utilizes raster matrix technology to generate plots with 100 dots/in density on plain paper at 15 ipm. By using standard fanfold paper, T-1100A reduces paper costs by 75%, because price/sheet is 0.5¢ vs. 2.0¢ or more/sheet for special sensitized paper in electrostatic units. T-1100A handles forms 4"-16" wide with up to 5 carbon copies. Since it uses no chemicals, continuous paper motion is not required and the T-1100A may be completely stopped for extended periods of time. Recognized by UL, under EPD 478, T-1100A prints 150 lpm with a standard 96-char. set. Additional capabilities include underlining, double high characters, 6 and 8 lpi, and lower case characters with descenders. **Trilog**, 17845 Skypark Circle, Irvine, CA 92714. (714) 549-4079. **Circle 162**

Adtech "Power Miser" Linear Power Supplies

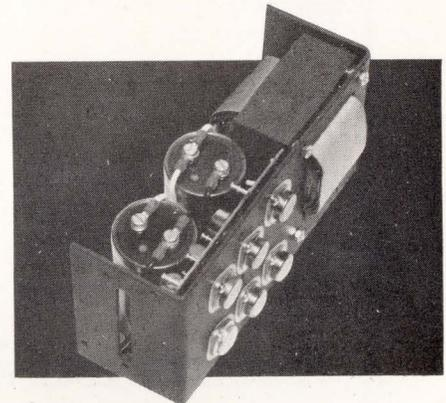

Manufactured in France
for European users.

Available through these
European distributors:

FRANCE

Omnitech
Paris (1) 257-62-80
Paris (1) 874-18-88

Texas Instruments

Le Plessis Robinson
(1) 630-23-43
Grenoble (76) 90-45-74
Toulouse (61) 21-30-32
Rennes (99) 79-54-81
Nice (93) 20-01-01
Toulon (94) 94-85-11
Strasbourg (88) 22-04-07

GERMANY

Neumuller GMBH
Taufkirchen-Munich
089-6118-1
Berlin 030/247212
Dusseldorf 0211/490325
Kornwestheim 07154/23330

Texas Instruments

Freising 08161/801
Munich 089/325011
Stuttgart 0711/547001
Frankfurt-Griesheim
0611/399061
Essen 0201/233551
Hannover 0511/648021
Berlin 030/8927063
Hamburg 040/2296478

BENELUX

De Buizerd Elec. BV
The Hague 070-469505

ITALY

Dott. Ing. G. de Mico S.P.A.
Bologna (051) 555614
Banchette (Ivrea)
(0125) 422300
Padua (041) 652909
Rome (06) 316204
Turin (011) 874137
Milan (02) 653131

SCANDINAVIA

E.V.J.
Copenhagen (01) 839022

Electro Power
Oslo, Norway (02) 463253

Noack AB
Stockholm (08) 670820

SWITZERLAND

Seyffer Co. A.G.
Zurich 01/628200

UNITED KINGDOM

Texas Instruments Ltd.
London, Slough 33411
Southampton 0703-27267
Bedford 0234-67466
Stockport 061-432-0645
Edinburgh 031-229-1481

For Application Assistance, Contact

Adtech International

SUBSIDIARY OF ADTECH POWER, INC. ANAHEIM,
CALIFORNIA 92806 U.S.A.

46 BD. Roger Salengro, 78200 Mantes
La Ville, France. Telephone: 4775301+

UP ON DEC!

PDP-11[®] LINE PRINTER CONTROLLER For Centronics[®] or Dataproducts Type Printers

Operates on any PDP-11 computer without hardware or software modification.

Incorporating low power Schottky TTL logic and a unique self-test mode for simplified installation, the DLP-11 Line Printer Controller comes complete with all cables and connectors.

Immediate delivery. \$750
Single Quantity

OEM and quantity discounts available.

NEW! From
Datatypes



Datatypes Corporation
8716 Production Ave.
San Diego, CA 92121
(714) 566-5500

*DEC and PDP are registered trademarks of Digital Equipment Corporation.
*Centronics is a registered trademark of Centronics Data Computer Corporation.

Circle 43 on Reader Inquiry Card

CAT-100 GETS COLOR!

TOTAL GRAPHICS — The CAT-100/C is the original graphic system with high-resolution video image digitizer for the S-100 bus.

When you need input for computer graphics, you no longer have to digitize a picture point by point. The CAT-100/C does it for you in 1/60th of a second with resolutions from 256 up to 1,280 points per line. It buffers the data in its own 32K-byte memory (expandable to 256K) and displays the digital image on a standard B&W or color TV monitor. Packed with a large variety of functions, the fully loaded CAT-100/C is priced at

Main video output: D/A conversion with built-in gray scale and color

3 auxiliary video outputs

Photographic trigger input

Test points and signals for custom interface

Video input: built-in real-time 1, 2 or 4-bit A/D conversion

Lightpen input

Expansion bus for additional buffer capacity

\$1,200.

Models with fewer functions start at \$750.

Built-in expandable 32K-byte graphic/alphanumeric buffer

Built-in 7x9 full ASCII character generator



595 Matadero Avenue, Palo Alto, CA 94306
415/494-6088

Circle 44 on Reader Inquiry Card

NEW PRODUCTS

DISK COPY PROGRAM

A fast disk copy program for the Intel MDS family of development systems runs under the ISIS-II operating system and will copy an entire single or double density diskette in less than one minute. The user may optionally specify that the object diskette is to be formatted, and/or that a verification of the object disk is to be performed. It will copy any standard format single or double density diskette. Xener Corp., 6641 Backlick Road, Springfield, Virginia 22150.

Circle 203

32K STATIC CMOS ROM

The 32 Kbit fully-static CMOS ROM (CM3200), organized 4096X8, consumes 10µA standby and 10mA operating. This fully static (no clock input required) 24-pin DIP provides 450 nsec (max) access and cycle times. Its industry-standard pin-outs make it a direct replacement for TI's TMS4732, Motorola's MCM68A332, AMI's S68332, Signetic's 2632 and Synertek's SY2332. Supertex, Inc., 1225 Bordeaux Dr., Sunnyvale, CA 94086. (408) 744-0100.

Circle 204

NETWORK CONTROL UNIT

The CU355, a fully solid state universal network control unit with PROM is for interfacing high speed data terminals and word processing machinery to most common carrier and private switched networks. Control unit to terminal signalling level is RS232C and model CU355 accommodates Western Union Low Level or RS232C compatible modem on the network side. The unit can accommodate 2 terminals and 1 monitor position at speeds up to 9600 baud. In addition, the CU355 has an alpha or numeric keypad for ease of operation in line conditioning, signalling and dialing. Multiplex Communications, Inc., 123 Marcus Blvd., Hauppauge, New York 11787.

Circle 205

RUGGEDIZED RMO3

The C2-RM03 disk drive is basically a ruggedized version of DEC's RM03. It is 19-in. rack mountable, 3 ft tall and 30 in. deep. A closed-loop air system keeps out contaminants and was configured so that there is complete front access to the device. The disk contains 67 mbytes of usable data, has an average access time of 38 msec and data transfer rate of 1200K byte/sec. The unit interfaces with the military Massbus, is also compatible with DEC hardware and software. Norden Systems, Norwalk, CT 06856.

Circle 207

FLOPPY DISK FOR LSI-11/2

The FD-211 double density dual floppy disk system for the LSI-11 is instruction set and pin compatible with DEC's RX02 system. All controller electronics are mounted on a single dual-height card which plugs directly into the LSI-11 or LSI-11/2 backplane. The dual-height controller card contains bootstrap loader (eliminating need for DEC's BVD-11 bootstrap loader card), IBM 3740 formatter, and interface circuitry. The FD-211 is downward compatible with all single density media and hence can be used with diskettes written for a single density and/or double density operation. Data is DMA transferred on per-sector basis. Mounted in a 5¼" enclosure, the FD-211 system uses Shugart SA800 drives. Each drive has a LED to indicate Read or Write operation, a Write-Protect sensor, and automatic head unload. Write-Protect switches are also available on the enclosure front panel. \$3,250. Charles River Data Systems, 4 Tech Circle, Natick, MA 01760.

Circle 197

VIDEO DIGITIZER COLOR GRAPHICS SYSTEM

The Cat/C, an integrated, expandable, general-purpose video imaging system for the S-100 bus, consists of two standard-size S-100 boards. It offers a large number of useful and innovative features, including high-resolution standard color video output. It accepts standard monochrome TV signals as input with a variety of synchronization choices: the automatic composite sync extractor will operate on EIA RS-170, RS-330 or random interlace sync. Two selectable A/D conversion circuits provide a choice of 1, 2 or 4 bits/pixel at max. video rate, and a complete video frame can be digitized in 1/60 sec. From \$750. Digital Graphic Systems, 595 Matadero Ave., Palo Alto, CA 94306. (415) 494-6088.

Circle 167

IMPROVED CRT TERMINAL

The 1410 economy computer terminal is based on Hazeltine's earlier entries into the microprocessor-based video terminal field, the 1400 and 1500 series. Optimum reli-



bility is achieved through containment of all electronics on a single printed circuit card, thus eliminating all interconnections other than input power and monitor connections. The circuitry must pass through a series of stress tests before it can become part of the electronic assembly. The 1410 eliminates the need for a fan because of its significantly cooler operating temperatures. The new unit operates with a standard EIA RS232 interface with eight transmission rates up to 9600 Baud, and it accommodates all 128 ASCII codes. \$580 (1000). **Hazeltine Corp.**, Greenlawn, NY 11740. **Circle 175**

SERIES/1 GRAPHICS SYSTEM

A parallel interface system allows IBM Series/1 users to interface the Megraphic 7000 interactive refresh graphic terminal to their computers. The 7000 system has self-contained refresh memory, 12-bit resolution and a unique 32-bit microcontroller and word-length. Selective erase, hardware translation, blinking and dashed lines are standard provisions with hardware rotate, scale, clip and zoom optionally available. The 7000's dual bus structure interfaces with I/O devices through the separate peripherals bus, insuring that the 32-bit graphics bus is not slowed by routine peripheral interrupt servicing. **Megatek**, 3931 Sorrento Valley Blvd., San Diego, CA 92121. **Circle 170**

VIDEO DISPLAY/ TRANSPARENT MEMORY

A 24 x 80 character alphanumeric video interface card for the S100 bus, the ALTR-24, allows a CPU to access the refresh memory at



any time. The display is glitch free, and the CPU is never interrupted. The method does not rely on the peculiar timing characteristics of a particular CPU and permits its use with most micro and mini minicomputers. The transparent memory design utilizes a multiplexing technique which permits non-conflicting access by both the CRT controller and

CPU. So far, the transparent memory feature has been incorporated into the three industry standard buses besides the S100 bus, including the Intel/National SBC-80; DEC LSI-11/2 and Motorola Exorcisor. All cards in the series feature memory mapped addressing. This allows the full power of the processor's instruction set to be used for display data manipulation. The 128 location character generator features the full ASCII set including upper and lower characters as well as limited graphics. A 2 x 7 dot matrix in a 6 x 10 dot cell is used resulting in a non-interlaced completely flicker free display. A compatible family of graphics controller cards with variable resolutions ranging from 256 x 256 to 512 x 256 points is also available. \$265 (100). **Matrox Electronic Systems Ltd.**, 2795 Bates Rd., Montreal, Que H3S 1B5. **Circle 176**

ADDS TEXT PROCESSING CAPABILITIES

A ROM firmware chip, which plugs into an Apple computer with no modification, adds the full ASCII character set, including lower case, plus 31 other useful, non-ASCII char-



acters. It also enhances editing capabilities for program and data modification. The chip is compatible with existing Apple programs — Interger Basic and Applesoft. \$99.95. **Eclectic Corporation**, 2830 Walnut Hill Lane, Dallas, Texas 75229. **Circle 173**

INTERFACES 4 DISKS TO DG

Up to four "Storage Module", "Winchester" or "3300" type disk drives can be interfaced to any Data General Nova or Eclipse computer, providing an on line storage capability up to 1.2 billion bytes. Occupying a single slot in the host computer mainframe, the controller board provides multiplex capability for disk files with data transfer rates ranging from 806 kbytes to 1.2 Mbytes per second including CDC 9730/60/62/64/66, Ampex 940/80 and 9100/200/300, Memorex 601 and 677 and Ball Computer BD 50/80 disk drives. All drives can be intermixed on the same data bus regardless of capacity, organization or transfer rates. Utilizing a proprietary ECC method of error correction, the 3255 can perform error correction on bursts of up to 11 bits in length, as well as detect all burst errors of up to 25 bits. The 3255 supports multiple record length format, has provisions for bad-track flagging and is capable of alternate track sparing. The controller incorporates a 2K byte, FIFO data buffer that allows matching of processor and disk drive data transfer rates. Automatic diagnostics are performed under microprocessor control. The 3255 can perform multi-record transfers with automatic head advance over head and cylinder boundaries. \$3500. **Ball Computer Products**, 860 E. Arques Ave., Sunnyvale, CA 94086. **Circle 191**

MFM floppy, 1 head or 2

AED's field-proven 6200 Series floppy disk system has recently been expanded to provide the minicomputer user with a wider choice of disk drive capability. The AED6200 Series now offers double density (MFM) systems in four configurations: 2 drives with single head (5 1/4" and 7" cabinets), 4 drives with single head (10" cabinet), 2 drives with dual head (7" cabinet) and 4 drives with dual head (two 7" cabinets). All systems come complete with formatter, power supply, drive electronics and CPU interface. Interfaces for LSI-11, PDP-8 and 11, Nova/Eclipse, Varian, Interdata and CAI are all available from AED.

Here is a checklist of the AED6200's outstanding user benefits:

- low cost, fast access storage
- 1.2 megabytes/diskette
- industry standard 8" media
- programmable formatter for ideal record size
- multiple source drives
- 8 computer interfaces available
- expandable to 4 drives
- CRC and IPL for easier loading
- delivery from stock on all popular models

Get all the facts by calling or writing our Marketing Manager today.

Advanced Electronics Design, Inc.
440 Potrero Ave., Sunnyvale, CA 94086
Phone 415-733-3555, BOSTON
617-275-6400, FULLERTON 714-738-6688.



AED 6200

gives you more for your mini



Circle 45 on Reader Inquiry Card

THOMSON
instrument

BALL BUSHINGS

for
linear motions

- SUPERSENSITIVE LINEAR MOVEMENT
- EXTREMELY SMALL SIZE • LOW FRICTION
- and WEAR • LASTING PRECISION
- ALIGNMENT • ELIMINATE BINDING and
- CHATTER • ZERO SHAKE or PLAY
- LONG LIFE — LOW MAINTENANCE
- SOLVES SLIDING LUBRICATION PROBLEMS



Used by progressive engineers in the latest guidance, fire control and navigation systems, computers, inertial devices, instruments.

Various types of BALL BUSHINGS are made for shaft sizes from 1/8" to 4" . . . with small sizes available in Stainless Steel. We will promptly send, on request, catalog containing complete technical information, prices and name of our representative in your city.



THOMSON
INDUSTRIES, INC.

Dept. U
MANHASSETT
N. Y. 11030

Tel. 516 883-8000

Manufacturers of BALL BUSHINGS,
ROUNDWAY Bearings, 60 Case,
BRONZE Case, NYLINED Bearings,
WAYMOUNTS, MILL-DRILL Tables.



Circle 46 on Reader Inquiry Card

Discover What More & More Engineers Are Discovering

Our over 138,000 direct and pass-along readers who read **Digital Design** include industry's leading designers and design managers. Do they know something you don't? They do if you don't subscribe to **Digital Design**. So, if you're not a subscriber, start now. Discover what more and more engineers are discovering in application articles ranging from μ Cs and μ P memories to instrumentation to computer printers — that what you will learn will not only help you select products but will also save you breadboarding, debugging design and programming time. And it doesn't cost you a cent. If you're actively involved in design or managing, you can get a free subscription. To send for a qualification card, write to —

Digital Design

1050 Commonwealth Ave., Boston, MA 02215
(617) 232-5470

NEW PRODUCTS

RECEIVE-ONLY PRINTER (9600 BAUD)

The Minitem Model 1201 can accept burst transmissions up to 9600 baud into either a 2K or 4K buffer memory and print out at 50 cps. This allows CRT units to "dump" a full screen of data into the buffer at 9600 baud and allow them to immediately continue with further editing while the previous output is being printed. **Computer Devices Inc.**, 25 North Ave., Burlington, MA 01803 **Circle 208**

FLOPPY NOW IN TWO VERSIONS

A double-density floppy disk drive comes in two versions. Model B51 is single-sided, storing up to 250K bytes of data on one side of a 5.25-in. diskette. Model B52 reads/writes on both sides of the diskette, giving direct access to 500K bytes. An automatic diskette positioning and ejector mechanism pre-positions the diskette over the spindle hub before the clutch centering device is engaged. This facilitates precise alignment of the diskette for operation. A band head-positioning device reduces track-to-track access time to 5 msec, which is more than five times as fast as competitors. In this development the stepper motor turns a precision pulley, built to tolerances of .0001 in, which moves the recording head forward or backward to a track. Both models of floppy disk drives will accommodate FM, MFM, M²FM or GCR encoding techniques. **Micro Peripherals Inc.**, 21201 Oxnard Street, Woodland Hills, CA 91367. **Circle 200**

1200-BPS DIRECT CONNECT MODEM

Designated the P-202S, the 1200-bps modem is a direct-connect unit that interfaces directly with the two-wire, dial-up switched telephone network through a 97A or 97B jack. A Data Access Arrangement (DAA) is not required. Users can connect the P-202S to the switched network in any of three standard modes: programmable, fixed loss or permissive. Card version, \$340. **Prentice Corp.**, 795 San Antonio Rd., Palo Alto, CA 94303. **Circle 210**

DIABLO-COMPATIBLE PRINTER

The Spinwriter Model 5515 receive-only terminal and Model 5525 keyboard send-receive terminal are μ C-controlled serial impact printers that operate on communications lines at data rates up to 1200 baud and print at speeds of up to 55 cps in an on-line communications environment. Both printers support RS-232-C communications interface, as well as an optional current loop interface. The printers duplicate the escape-code sequences used in Diablo 161Q and 1620 terminals, which are also marketed under the names Xerox 1700 and 1710. Pricing for the terminals is competitive. In end-user single-unit quantities, the Model 5515 \$2,910; 5525 \$3,310. **NEC Information Systems, Inc.**, 5 Militia Dr., Lexington, MA 02173. **Circle 196**

ULTRA-RELIABLE nKRA RAM BOARDS IN 16K, 32K, 48K, AND 64K BYTES

A family of four dynamic RAM boards offer capacities of 16K, 32K, 48K and 64K bytes. A minimum of components are used to reduce probability of failure and ICs are mounted in sockets. Quality control includes complete functional test of boards, 48-hr dynamic burn-in at 140 degrees F, complete diagnostic test and maintenance of a test history for every board shipped. Refresh is synchronous, so no wait states can slow the μ C. With the bank select option, memory may be expanded beyond 64 bytes with all memory on-line continuously. **Processor Technology Corp.**, 7100 Johnson Drive, Pleasanton, CA 94566. **Circle 199**

9600-bps MODEM FOR PRIVATE LINES

Full-duplex, point-to-point operation over leased, voice-grade telephone lines is available through a modem that transmits and receives serial binary data at a rate of either 9600 bps or 4800 bps depending upon an internal switch setting. The 7296 can also be used over the public switched network using 7812 line adapters and by making two DDD calls. Telephone network connections are made either to a six-terminal barrier strip or to a 25-pin connector on the rear panel. Data terminal equipment connections are made to an EIA standard 25-pin connector. \$4900 (4-10). **Tele-Dynamics**, 525 Virginia Drive, Fort Washington, PA 19034. **Circle 209**

PORT CONCENTRATOR

The Micro200 port concentrator allows user of MICOM's Micro800 data concentrator to save computer ports as well as telephone line costs. Aimed particularly at users of mini-computers, the concentrator offers substantial cost savings by allowing one computer port to communicate with up to 16 channels on a remote Micro800 data concentrator



using a very simple asynchronous or synchronous protocol. Some user programming is required to communicate with the port concentrator, but the Micro200 offers a simpler interface than has previously available. \$1,000. Micom Systems, Inc., 9551 Irondale Ave., Chatsworth, CA. 91311. **Circle 171**

DECWRITER MODIFICATION ADDS GRAPHICS

A low cost graphics modification to the DECwriter printer allows vector generated graphics, expanded character styles, improved speed, and numerous DEC offered options as standard. The Graphics II system consists of a replacement circuit board for the DECwriter II and is plug compatible with internal cables. The new circuit board uses the F8 microprocessor. The Graphics II allows printing of a dot anywhere on the page; a total of 1,045,440 addressable points are available per page. Bidirectional line feed is introduced and the Vector Graphics capability allows printing a line between any two points on the page by specifying the end point coordinates using ASCII characters; this means that graphics can even be generated by using the printer keyboard. Two complete character sets are included (ASCII & APL) as standard and other character sets can be used instead. Selanar Corp., 3054 Lawrence Expressway, Santa Clara, CA 95051. **Circle 174**

PDP-11 DISK CONTROLLERS

Compatible, microprogrammed controllers meet large disk storage requirements of PDP-11 computer users. The SC11/A controller emulates the DEC RP11/RP02/RP03 subsystems; the SC11/B emulates the RH11/RM02/RP04/RP05/RP06 subsystems; and the SC11/C emulates the RK611/RK06/RK07 subsystems. Each controller incorporates an

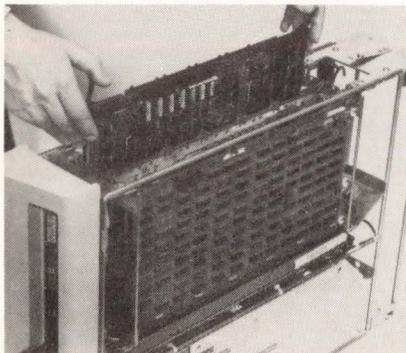

automatic self-test capability plus extensive subsystem diagnostics in on-board firmware, and special operating functions can often be added. The controllers use two printed circuit boards that can be plugged into any pair of standard SPC slots to minimize space requirements; simplify spares stocking requirements; avoid specially wired system units or backplanes; and reduce the component count. \$3900(50). Emulex, 17785 D Skypark Circle, Irvine, CA 92714. **Circle 198**

REVISED 488 BUS STANDARD

IEEE has just published the revised "IEEE Std 488, Standard Digital Interface for Programmable Instrumentation". New information is provided for: system controller guidelines, devices powered off and on, serial poll, parallel poll configure, interface function capability identification and data rate consideration for high speed operation. A number of tables and figures have been modified, notes have been added to further explain conditions and provisions, and some specifications have been broadened. Other changes have been made to provide clarification. \$10 (\$9 for IEEE members), plus \$2 for shipping. IEEE Service Center, 445 Hoes Lane, Piscataway, NJ 08854. **Circle 186**

VOICE RESPONSE FOR MICRO

An electronic voice response synthesizer is an optional attachment to Radio Shack's TRS-80. The Votrax synthesizer converts computer output into electronically synthe-

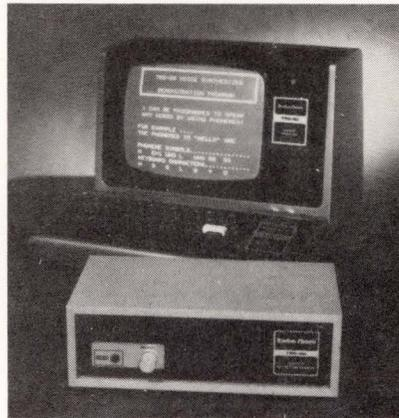

sized speech by producing words and phrases utilizing phonemes (the basic sounds of spoken language). Votrax, 500 Stephenson Highway, Troy, MI 48084. **Circle 172**

S6802 AND S6808 MICROPROCESSORS

Two μ Cs — the S6802 and S6808 — further integrate system functions onboard the 6800 chip family. The μ Cs are depletion-load N-channel devices available in 40-pin ceramic or plastic packages. Both chips are object-code compatible with the S6800 and can address up to 64K bytes of memory. Each includes the clock circuitry on-chip, thus eliminating the 6875 clock chip required with earlier 6800 μ C. The S6802 also includes 128 bytes of RAM (32 bytes retainable under standby power in power-down situations). Both the S6802 and S6808 need only a crystal for operation. They are 1MHz devices, using the divided down output of a 4MHz crystal. American Microsystems, Inc., 3800 Homestead Road, Santa Clara, CA 95051. **Circle 201**

EMULATOR CONTROLLER

The AED8000 emulator/microcontroller provides cost effective data control and intermediate data buffering between your CPUs and Mass Storage disks. A total of 8 disk drives in any combination, including Winchester, can be utilized at one time; and up to 4 CPUs can be interfaced through the AED8000 Microcontroller interface electronics. The AED8000 emulates the OEM disk controller through generational changes, saving you money by not requiring you to write the software driver over and over again. And the controller not only runs the software for the emulated disk, but runs the mainframe manufacturer's disk diagnostics as well!

Here is a checklist of the AED8000's outstanding user benefits:

- RP-03, RP-04 and RP-06^{®1} emulation
- microprogrammable 24-bit power
- writeable control store microcode
- controls 8 storage module drives
- handles SMD and Winchester drive mix
- handles any combination of Ampex, Calcomp, CDC, ISS and Memorex drives
- 56-bit Fire Code Error Correction
- 256 x 16-bit data buffer

Get all the facts by calling or writing our Marketing Manager today.

®¹ Registered trademark of Digital Equipment Corp.

Advanced Electronics Design, Inc.
440 Potrero Ave., Sunnyvale, CA 94086
Phone 415-733-3555, BOSTON
617-275-6400, FULLERTON 714-738-6688.

AED8000
gives you more for your mini

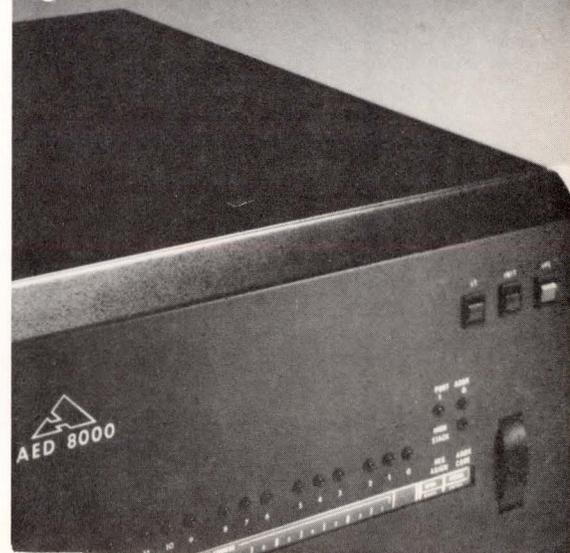

Circle 47 on Reader Inquiry Card

NEW PRODUCTS

BISYNCHRONOUS TO ASYNCHRONOUS

The SDE80/10 series of microprocessor based communications interfaces is capable of synchronous to asynchronous communications interfacing and can be configured as either a single or multiple line system. Typical applications include emulation of IMB 2780/3780 RJE terminals, or communicating 3741 stations, by asynchronous terminals or computers. The SDE80/10 can also be used to give the speed and data integrity of synchronous block protocols to



asynchronous point to point communications. \$2500-\$3500. **Sherwood Digital Electronics Corp.**, 4304 So. Main Street, Salt Lake City, UT 84107. **Circle 190**

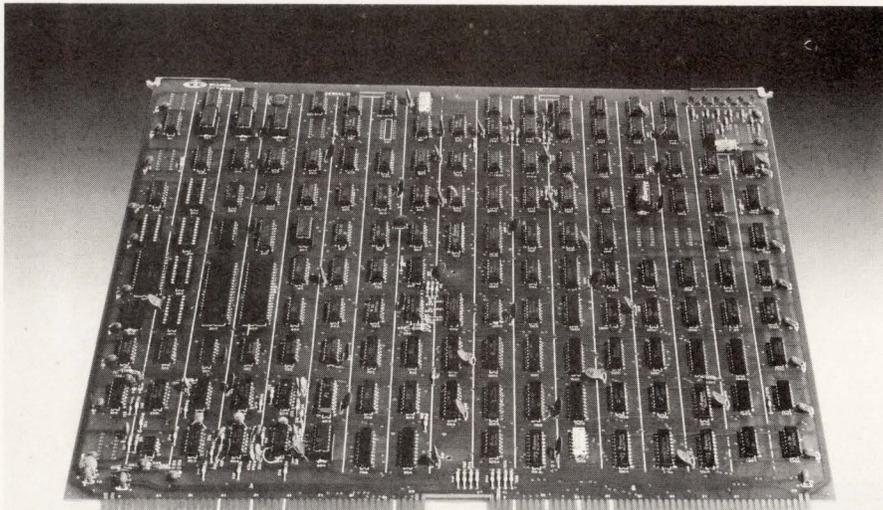

Made for each other: Your Data General Computer— Our Storage Module Controller.

Our 25XX Controller interfaces Data General computers with Ampex, CalComp, CDC, Hitachi, Okidata, or Microdata storage module disk drives, and you won't find anything like it anywhere else.

For example, it's software transparent—you don't have to change programs to use it. Its format program is built into the firmware. It's microprocessor-controlled. And it automatically selects alternates to bad tracks without operational software intervention.

Optionally, it controls up to four 300-megabyte disk drives.

The Controller consists of a single plug-in circuit board containing four registers:

- Status—16 bits read only
- Memory Address—16 bits read/write
- Command/Cylinder Address—16 bits write only
- Disk Address/Sector Counter—16 bits read/write.

The 25XX Controller, configured to your requirements and complete with necessary cabling and external rack mount level shifter panel (where required) is available for 30-day delivery from:



ELECTRONICS, LTD.

2535 Via Palma Ave. • Anaheim, CA 92801
Telephone: (714) 995-6552

Contact us for all your Data General controller needs.

Circle 48 on Reader Inquiry Card

NOVA/ECLIPSE DISK CONTROLLER

All computers of the Nova and Eclipse type can now accommodate up to four storage module type drives with the 850 disk controller providing storage capacity of 1.2 billion bytes of unformatted data. Utilizing a microprogrammable processor, the 850 emulates the Data General 606X. The disk controller is completely resident on one printed circuit board. Improved reliability due to lower power needs, as well as better access and less space requirements result from this innovative packaging approach. The controller operates with Data General RDOS and AOS or independent BLIS/Cobol or IRIS software. Media compatibility with the Data General 606X can be obtained with Memorex 601 or 677, and CalComp T-100 or T-200 drives with storage module type interface. Key features of the 850 are automatic position verification, ECC, multiple computer access, DMA throttle, implied seek, overlap seek for multiple spindle applications, bad sector flagging, sector interleaving, unique logical disk drive addressing, and disk read error recovery. \$3,600. **Xylogics, Inc.**, 42 Third Ave., Burlington, MA 01803. **Circle 193**

GENERIC PERSONALITY MODULE

A generic personality module enables Pro-Log Series 90 PROM programmers to program Intel's single-chip microcomputers and related support devices. The new Pro-Log Model PM9054 is designed to allow programming of all generic Intel MCS-48 device

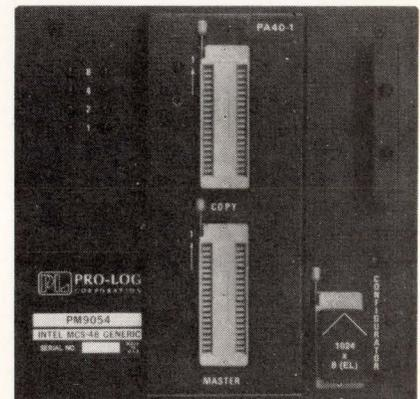

types. It provides the control lines and timing necessary to list, program, duplicate and verify the device memories using Pro-Log's M900 and M900B PROM programmer master control units. **Pro-Log**, 2411 Garden Rd., Monterey, CA 93940. **Circle 181**

DIGITAL TEXT

"The Logical Processing of Digital Signals," by Dr. S. L. Hurst is a 580-pg. text that allegedly "is not just another digital logic text." After surveying binary and higher-valued logic and logic functions, it covers binary logic networks using threshold-logic gates. Other topics covered include logic network design using spectral techniques and ternary logic networks. \$47.50. **Crane, Russak & Co., Inc.**, 347 Madison Ave., New York, NY 10017. **Circle 188**

MILITARIZED STAND-ALONE 4.3 MEGABYTE CARTRIDGE TAPE

A tape cartridge system, Model 5100-R, for use with the ROLM series of militarized μ C, stores 4.3 Mbytes of unformatted digital data on the 3M Company's new high capacity tape cartridge, or alternatively, 2.8

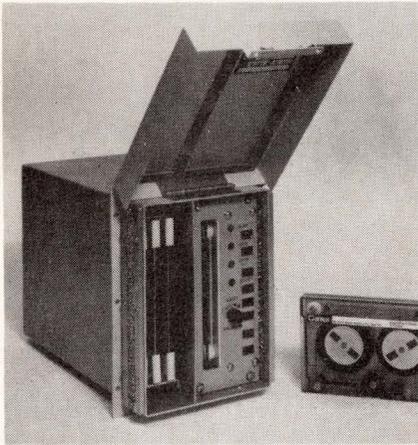

Mbytes on the standard 3M DC300A cartridge. Tape speed is 30 ips for read/write operations, and 90 ips for fast search and rewind. At 1600 bits/in. recording density, the unit records and reads data at 48,000 bit/sec., enabling it to load a 30,000 byte program within 5 sec. \$6875. Quantex, 60 Plant Ave., Hauppauge, NY 11787

Circle 194

INTERFACE BUS CARTRIDGE RECORDER

GPIB 3000, a General Purpose Interface Bus Cartridge Recorder utilizing the DC300A/DC300XL cartridge media, allows users of test equipment, calculators and other types of bus-compatible instruments to record on tape. GPIB 3000 adds data recording and playback capabilities to a wide range of instrumentation and data-acquisition systems without building custom interfaces. Tape and tape format utilized by GPIB 3000 meets ANSI/ISO/ECMA cartridge standards (ECMA-46). The drive - which plugs in directly to the IEEE-488 interface bus available on calculators, mCs and more than 100 types of measurement instruments - offers high-quality tape handling of 3M Data Cartridges and uses no belts, gears or brakes (relying on a single direct-drive servo motor). Interface μ P electronics provide full read and write data buffering, IEEE-488 standard interface, automatic error handling and simplified programming. Read-while-write data checking is performed while recording, ensuring error-free recordings. Recorded cartridges meet ANSI standard X3B5/75-44 for serial 1600 bpi recording. Four independent tracks are provided. Data capacity exceeds 2 Mbytes with standard cartridges. A table-top cabinet adaptable to rack mounting is available for both single- and dual-drive models. This drive is adaptable to a wide range of altitude, environmental, vibration and shock conditions, and it exceeds all accepted reliability standards. \$3620. Tandberg Data Inc., 4060 Morena Blvd., San Diego, CA 92117.

Circle 145

Wire Wrap Modules . . .

from MDB

For use in these computers:

- PDP*-11
- LSI-11
- PDP-8
- Data General
- Interdata
- IBM Series/1

When it comes to Wire Wrap Boards, MDB has them, all with these features:

- Plugs directly into the host computer backplane connecting all bus signals
- Two-level wire wrap posts on component side of module
- Mounts in a single chassis position
- Will accommodate any .300, .400 or .600" center dual in-line packages
- Pads for discretes
- All holes plated-through, UL approved FR4 material
- Multiple external I/O provisions on module
- Cable connections can be made to other MDB modules
- Optional sockets and wire wrap pins available

Quad Module for PDP-11, PDP-8 and LSI-11

Combinations of up to seventy 14 or 16 pin IC's or sockets; four I/O ribbon-cable edge connectors from 16 to 50 conductors.

LSI-11 Dual Module

Combinations of up to thirty-six 14 or 16 pin IC's or sockets; one continuous row of 90 pins for I/O connectors from 16 to 50 conductors.

PDP-11 Hex Module

Combinations of up to ninety-six 14 or 16 pin IC's or sockets; two continuous rows of 250 pins (top) and 130 pins (side) for I/O connectors from 16 to 50 conductors.

Data General Module

Up to 198 14 or 16 pin IC's or sockets; four I/O connectors from 16 to 50 conductors.

Interdata Full-board Module

Up to 197 14 or 16 pin IC's or sockets; two I/O connectors from 16 to 50 conductors.

Interdata Half-board Module

Up to ninety-one 14 or 16 pin IC's or sockets; two I/O connectors from 16 to 50 conductors.

IBM Series/1 Modules

Up to sixty-four or seventy-two 14, 16, or 20 pin IC's or sockets depending on module selection; two I/O connectors from 16 to 40 conductors.

MDB interface products always equal or exceed the host computer manufacturer's specifications and performance for a similar interface. MDB products are competitively priced, delivery is 14 days ARO or sooner.

MDB also supplies for these same computers an extensive repertoire of line printer and peripheral device controllers, GP logic modules, systems modules and communications/terminal modules. Product literature kits are complete with pricing.

MDB 1995 N. Batavia Street
Orange, California 92665
714-998-6900
SYSTEMS INC. TWX: 910-593-1339

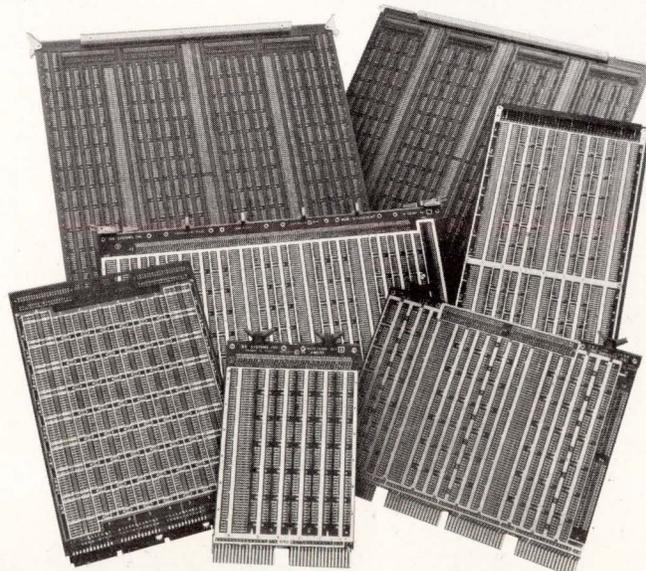

*TM Digital Equipment Corp.

Treat Yourself and Your Friends to Personal Computing

Start a new subscription to *Personal Computing*, for yourself and/or your friends, or renew/extend your current subscription, and you'll benefit two big ways. First, you'll receive each monthly issue of *Personal Computing*, the consumer magazine packed with business and home programs, programming techniques, buying guides, product news and other consumer information to help you make your computer a powerful tool for business and home.

Second, you can receive these bonuses:

- Buy more than one subscription (they make great gifts) and you'll pay \$2 less per year for each subscription after the first one. (And each extra subscription earns you a bonus issue added to *your* subscription.)
- Prepay your subscription or renewal/extension and you'll get *another* bonus issue per year added to your subscription. Prepay your gift subscriptions and each gift subscription receives the bonus issues, as well.
- For each gift subscription, we'll send a gift card in your name. Just check the box on the subscription order coupon.

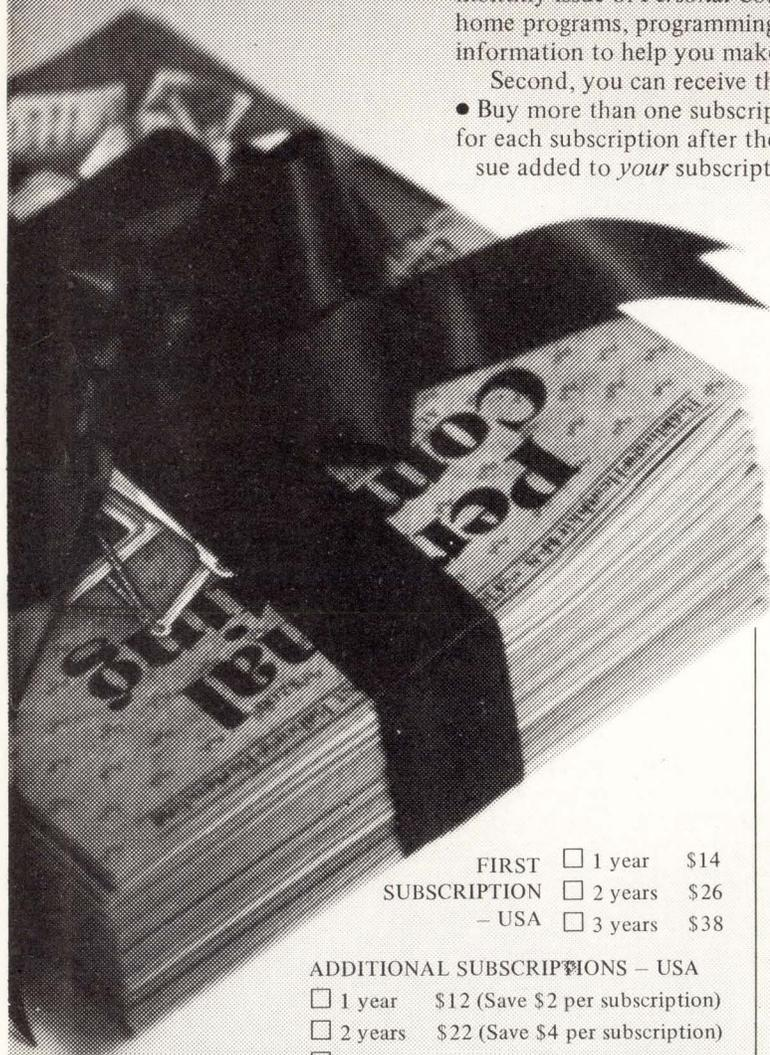

FIRST SUBSCRIPTION 1 year \$14
 2 years \$26
 - USA 3 years \$38

ADDITIONAL SUBSCRIPTIONS - USA
 1 year \$12 (Save \$2 per subscription)
 2 years \$22 (Save \$4 per subscription)
 3 years \$32 (Save \$6 per subscription)

ADDITIONAL POSTAGE - per subscription per year: Canada and Mexico - \$4 surface, \$8 air; Other Foreign - \$8 surface, \$36 air. Please remit US funds.

Check enclosed (and receive one extra issue for each year)

Charge my Master Charge Visa

Account # _____ Expires _____

Please start renew/extend my subscription to
Personal Computing

Name _____

Address _____

City _____ State _____ Zip _____

Also, send gift subscriptions in my name to:

Name _____

Address _____

City _____ State _____ Zip _____

Name _____

Address _____

City _____ State _____ Zip _____

Please send gift cards in my name.

To order more than two gift subscriptions, please make copies of this card. We cannot bill for gift subscriptions.

MAIL TO: **Personal Computing** 1050 Commonwealth Ave., Boston, MA 02215.

...Like buying a dead horse.

Getting stuck with the wrong technology is like buying a dead horse. Designing in the wrong switch technology is just as harmful as using the wrong encoding technology. Key Tronic Corporation offers encoding technologies ranging from the bare essentials to microprocessors, both our reed and capacitive switches offer over 100 million cycle reliability. The professional expertise of Key Tronic makes sure you don't get stuck with a dead horse. The industry's largest engineering staff wants to assist you in developing the most cost effective keyboard for your specific application. Take advantage of our experience and our service and you won't find yourself at a dead end!

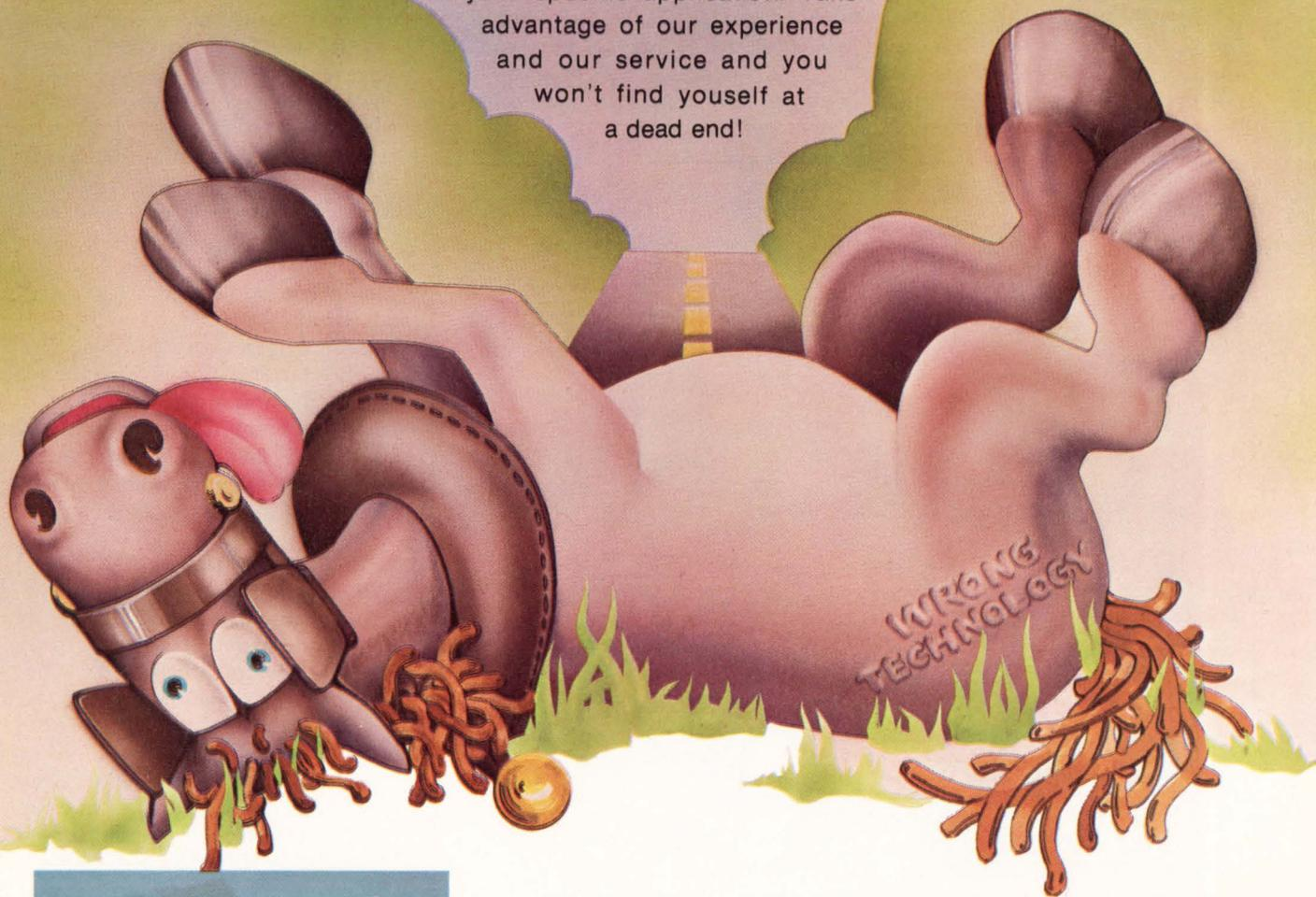

 **key tronic**
™

INTERNATIONAL KEYBOARDS

P.O. BOX 14687 — SPOKANE, WASHINGTON 99214 U.S.A. PHONE (509) 928-8000 — TWX 510 773-1885

Circle 55 on Reader Inquiry Card

MAGNETIC MEDIA MAINTENANCE

GOOD TAPE MANAGEMENT Saves Data and Cuts Costs

"We are the world's largest manufacturer of media maintenance equipment and we currently have over 10,000 units installed worldwide," states Richard K. Hurley, Vice President of Marketing at Kybe Corp. Kybe feels that once you lose your computer system, you can always borrow or lease time from another source. But lose your data, particularly if on tape (one of the most vulnerable media), then your system is down until you reconstruct the data.

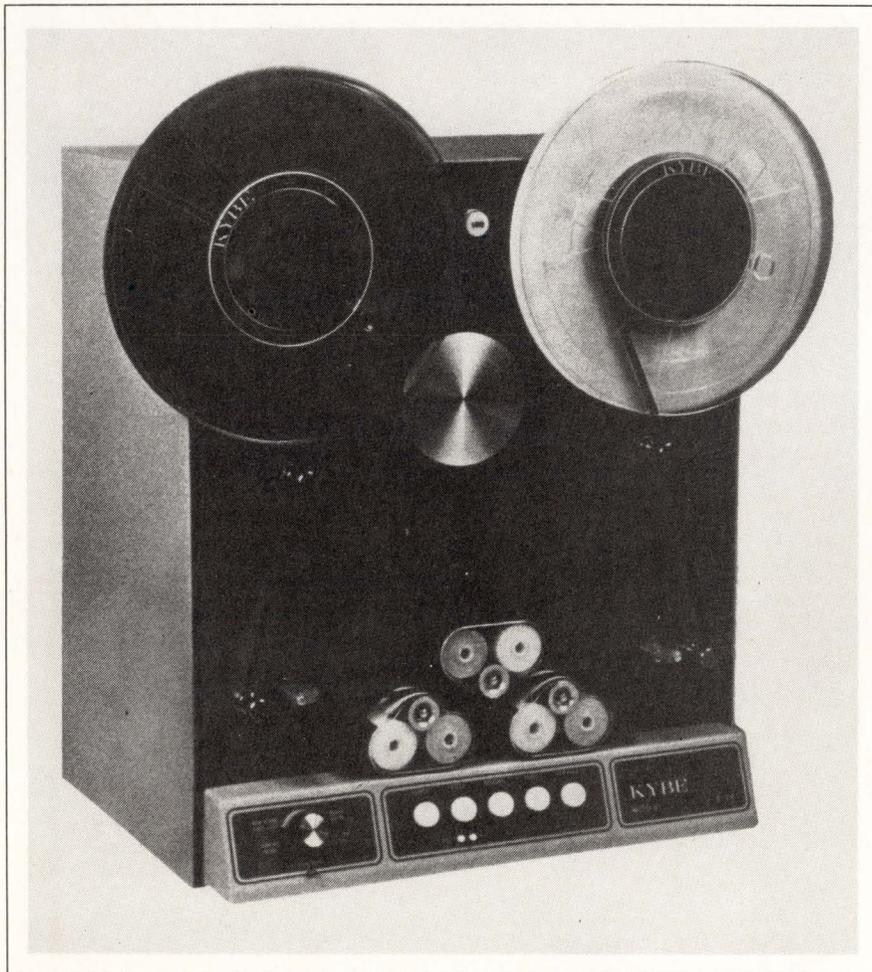

At 300 ips, Kybe's Mod VI cleans a 2400' reel of tape in approximately 1½ minutes and handles a full clean retention and restack cycle in 3 minutes. Its quick straight-line loading and industry compatible self-sealing hubs provide Mod VI's fast throughput.

Tape is often considered expendable due to its relatively low cost. In reality, it is impossible to establish the true monetary value of a given reel of tape as one has to consider the value of the data on the tape and the cost of reconstructing such data should it be lost through tape failure. Tape is the basic raw material of your library and it is the hallmark of successful companies that they impose strict quality control standards over their raw material.

Tape has an extremely long physical life, but may in fact reach the end of its economic life long before it reaches the end of its physical life. The "economic end of life" for tape is when it has acquired so many write errors that the value of the computer time wasted by using this tape over a period of time equals the tape's replacement value. Mathematically: $(\text{Number of write errors}) \times (\text{Cost per error}) \times (\text{Number of passes/yr.}) = (\text{Cost of new tape})$. That is, $15 \text{ write skips} \times \$0.02/\text{Skips} \times 50 \text{ passes} = \15.00 (approx. cost of new tape).

Tape degradation is occasioned by these factors: • contamination, generated by the tape, is an inherent condition which generally accounts for approximately 80% of all contaminants found on tape, • contamination which is generated by the environment in which the tape is used. (ie, paper dust from high-speed printers or card punches, dirty tape drives, improperly filtered air, etc), • physical damage from misaligned or misadjusted tape drives, • physical damage from improper handling by dp personnel and • built-in manufacturing defects (improper slitting, coating, curing, etc).

These factors are preventable in some instances and certainly controllable in most. Extensive maintenance coverage to ensure continued successful use of the computer and associated equipment is considered essential. Why should maintenance of the tape which is an integral part of the system be considered any less essential?

The use of Magnetic Tape Cleaner is the first step in a total preventive maintenance and corrective tape rehabilitation program which will help protect your investment and realize maximum operating benefits from your computer. You will reduce tape purchases by prolonging the reliable, useful life of the tape and reduce operating costs by minimizing reruns, rescheduling, extra shifts and the purchase of additional outside processing time and additional equipment. This will be accomplished in part by super-cleaning the tapes, thus reducing the chances of tape cinching and edge damage due to improper tension profiles and improper handling.

Contamination — its cause

Smoking, eating, unfiltered air or card and paper handling equipment in the computer room contaminates tape, but is secondary in nature, as 80% of all tape contaminants are self-generated. Tape is self-destructive by nature.

What causes self-generated contamination? Two basic causes exist.

Slitter trash. Tape is bulk manufactured in a web 24 to 48" wide and taped and then slit into 1/2" "pancakes". Slitting fractures the tape, generating lightly adhered-to-oxide and mylar particles on the tape edges. The tape is guided by these edges which come in direct contact with tape guides, reel flanges, heads, etc. This contact loosens some particles which often migrate to the recording tape's surface, producing "write skips" and/or "read fails".

Back-to-Front Transfer. The tape backing or mylar surface is always more contaminated than its recording or oxide surface. Why? Mylar is softer than oxide and abrades easier. Since the mylar surface comes in direct contact with more tape drive surfaces such as tape guides, vacuum columns, pinch rollers, capstans etc. (and has a natural static charge which attracts the abraded particles) then it's easy to picture the results. When tape is wound, one backing layer makes direct contact with the next recording layer. This layer-to-layer wind generates tremendous pressures and causes contamination transfer to the recording surface. The

The Optical Physical Defect Detector

E.P. Brandeis, *President*
Computer-Link Corp.

Between 6 and 10% of an average tape library contains one or more physical defects on a tape. While there are large variations, experience with several hundred tape users and several thousand tapes shows these numbers are representative.

Most errors were of the classic type. The only unexpected defect found was their oxide coating in which areas of a tape would be identified by the optical detector yet have no magnetic errors. Again, the thin oxide, while not an error today, certainly appears to be an abnormal condition subject to premature tape failure. One great advantage of the PDS is its ability to test a recorded tape. This has been very helpful in determining whether a job rerun with a particular tape would be a good risk or not by identifying if the tape has physical damage.

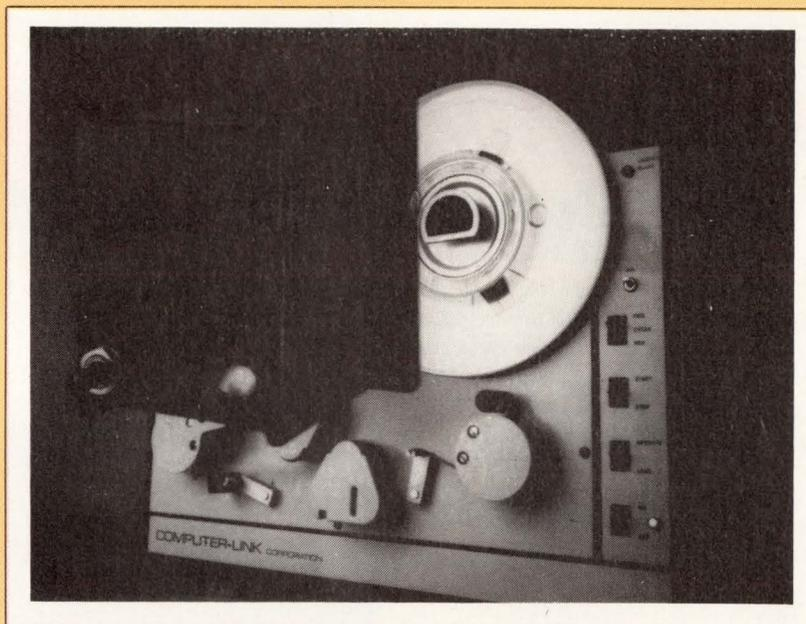

Computer-Link Corporation's Model 1011 Magnetic Tape Cleaner Rewinder with Physical Defect Scanner (PDS) cleans and scans scratched/failed tapes.

We found: (1) the PDS to be a repeatable, reliable detector of major (0.02") tape physical defects. The usefulness of a tape cleaner with PDS is greatly enhanced. (2) We found the combination tape cleaner-PDS to be a useful device in the computer room itself both for cleaning and scanning scratched and failed tapes. Throughput of cleaned and tested tapes was increased by use of operator personnel in addition to library personnel. (3) We found the unique dual tension capability of the Computer-Link cleaner a very useful tool in normalizing tape tension differences between off-line and computer system drives. The C-L dual capstan design permits independent simultaneous control of tape cleaning and winding tension. Therefore tape tension can be matched to facility requirements without sacrifice of tape cleaning tension. (4) The normal tape cleaner-tester remains as an invaluable library analysis tool in addition to its normal cleaning and testing capabilities as the PDS cannot detect nor differentiate the severity of magnetic errors on a tape (5) The regular use of any tape maintenance device — cleaner, scanner or tester is the secret to reliable tape library performance. Finally, remember that the occasional or haphazard use of the most sophisticated tape analyzer on the market will not produce reliable tape performance.

longer tape is stored or inactive, the more pronounced this back-to-front transfer phenomenon becomes. This is a main reason why we recommend cleaning and retensioning of long-term storage tapes at least once every six months.

... and its effect

When a contaminant passes over a head, head-to-tape separation occurs, reducing signal strength in direct relation to the contaminant height — not surface dimension.

When the signal falls below a certain (threshold) level, the tape drive no longer reads the signal (a "read fail" condition).

A smoke-size particle (0.25×10^{-3} in) reduces a signal at 1600 bpi by 95% — or below the 20% threshold level, and creates an error. The same

particle reduces signal by 45% at 800 bpi, which is above 32% threshold level and won't cause an error. Higher packing densities cause drive to be more sensitive to smaller particles.

Use a tape management system

Our "Tape Management System" evolves around cleaning, tape testing, recertification, precision rewinding and good tape handling. Our E-24 VI accomplishes two of these concepts on a single pass — as a tape cleaner and precision rewinding.

Since head-to-tape separation reduces signals and causes dropouts, cleaning tape must reduce contaminant size to re-establish better head-to-tape contact — minimizing signal loss. E-24 Mod VI utilizes a very sharp blade positioned at a precise angle of attack to slice off the peak of the con-

taminant, thus producing better head-to-tape contact. The loose or sheared particles are removed by three constantly self-advanced wiping tissue stations. Two wipe clean the tape's recording (oxide) side; the third wipes the back (mylar) side — a wiping action accomplished in both forward and reverse modes. Tissues advance automatically so no contamination is picked up by tape from the tissue. Each tissue spool lasts for 250 reels of tape.

As a precision rewinder, it uses a stacking wheel which ensures a smooth wind/stack to prevent damaging the edge of any individual tape layer. This stacking wheel also senses amount of tape on the take-up reel and controls the drive motors to produce a consistent tension profile over the entire tape length, thus reducing cinching.

INTELLIGENT MAINTENANCE Product Provides Field Upgradable Electronics

"Our Masteranalyst magnetic tape analyzer," says David B. Partridge, President of Data Devices International, "is one of the most important pieces of equipment manufactured. The Mark X, a tape cleaner, was released three months ago, while the Clean Machine — a disk cartridge cleaner — was released six months ago."

The Clean Machine, a portable low-cost disk cartridge cleaner, designed for speed, ease of operation and portability, utilizes pads which are pre-packaged in pairs and pre-soaked with a manufacturer-approved cleaning solution:

Additional Clean Machine features include: • top-load and front-load models are available, • employs a mechanized factory cleaning technique, • Unit is totally self-contained and portable, • Utilizes pre-soaked and pre-packaged cleaning pads for "no muss, no fuss" operation, • incorporates single push button control, • fast 24-sec. cycle time and • fail-safe operation protects media during power failures.

The 659 Series is a magnetic tape cleaner and analyzer (leased or purchased separately or together) and has field upgradeable electronics, μP function control, programmable analysis and buffered memory. The vacuum column tape transport cleans tape at 500 ips. Analysis cycle is 250 ips.

The user can purchase a cleaner for initial use and upgrade later to an analyzer without obsoleting his equipment. It means greater flexi-

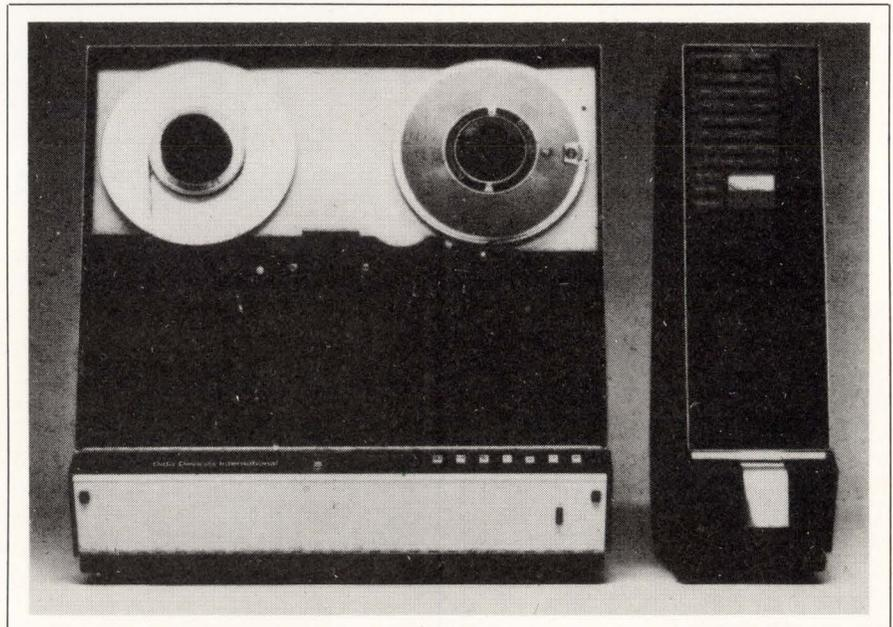

Data Devices International's "Mastera" analyzer electronics can be upgraded at customer site from 1600 BPI to 6250 BPI. Other options can be added.

bility for multi-machine users by providing an interchangeable spare cleaner or analyzer package. Further, analyzer electronics can be added in the field without returning the tape cleaner to the factory.

The field upgradeable electronics also allow users to change their equipment from 1600 BPI to 6250 BPI. Future major computer technology improvement can also be accommodated on this equipment in the field.

PREVENTIVE MAINTENANCE

Helps Prevent Downtime Woes

Staff Report
Texwipe Co.

The result of undetected build-up of contaminants on magnetic media surfaces are anything from signal dropout noise transients, gibberish data to memory loss and costly computer downtime. Any discussion of contaminants and their removal is incomplete without defining surface areas that require cleanliness. Critical minicomputer system components are: R/W head, capstan, guides, rollers — of the tape transport, disc packs, disc cartridges, recording heads — of the disc drive, character drum, hammers, and electro-mechanical parts of the printer, visual display screen of CRT terminals. The undetected contaminant build-up on these surfaces causes signal dropout, noise transients, gibberish data to memory loss and costly downtime.

A common problem occurs from a lack of cleaning and results in serious repercussions in the head crash. Properly positioned heads fly at 50-300 μ in above the spinning disk surface. The disc rotates at 2400-3600 RPM at 64-93 MPH. When dust particles, oxide or ceramic build-up get between the head and disc surface, they act as abrasives and scrape off magnetic material. If build-up is great enough, the head comes in contact with the contamination, disturbing the aerodynamics and causing the head to bounce over the obstacle in its path, touch down and smash into the surface of the disk causing data loss. Often the head crash destroys not only the disk but the head as well.

Periodic cleaning of tape units is an essential part of preventive maintenance. Dust, dirt and wear particles, can prevent the necessary contact between the oxide surface of the tape and the R/W head. Signal strength may be sharply reduced or recorded information may be completely obliterated. Any condition that causes the tape to be lifted as little as 1/1000" from the R/W head will cause the signal to fall below the sensitivity level.

Start an in-house maintenance program

Contamination is a continuous process. To compensate for its accumulation



Clearview Terminal Wipes are packaged in boxes of 72 (\$11) and 720 (\$75) or in Texwipe's Clearview Terminal Cleaning Kit, which contains products to clean, display screens for optimum visual clarity, and prevent static build-up.

and retention in an environment that is not controlled or specifically engineered for system performance, a regular program of in-house computer preventive maintenance should be instituted.

The following cleaning accessories are recommended for a contamination control program oriented to the mini-computer site:

1) WIPERS. Wipers used in cleaning peripheral equipment such as tape transports, disc drives, terminals, line printers must be, most importantly, lint-free and non-contaminating. These cloths should contain no binders, fillers or additives to affect the cleaning materials or the surface being cleaned. One such cloth, Texwipe, is woven and finished specifically for this type of application. ▶

Project Report on Mechanical Tape Cleaner

G.S.A. Region III
Washington, D.C.

Although mechanical tape cleaners have been marketed for approximately eight years, the use of razor blade edges as scraping tools has been introduced only recently. There is, as can be evidenced by results of machines offering both types of scraping devices, some advantage in cleaning efficiency with the razor blade edge. But several disadvantages discourage their use: (1) hazard to the operator, (2) potential for damaging tape, (3) physical wear on tape and (4) blade replacement necessary after cleaning such tape. For these reasons, although the highest efficiency was obtained with a machine using a razor blade as a scraping device, we cannot recommend such a technique.

The feeling is validated by sales representatives of two manufacturers. One of these recommends use of razor blades on old troublesome tapes only; the other specifically stated that he would not permit use of a razor blade type cleaner in an installation under his management. By his admission, the razor blade machine was offered by his company only as a competitive product.

Mechanical tape cleaning can, from the experience gained in this test, result in removing approximately 75% of the errors existing in an average magnetic tape library. The economics to be gained in this process are a function of tape procurement costs, computer costs, reruns due to tape errors, etc.

It was not the purpose of this project to determine the economic feasibility of mechanical tape cleaning, but only to determine the best available equipment.

MAGNETIC MEDIA MAINTENANCE PRODUCT SPECIFICATIONS

	MODEL NO.	CLEANS WHICH MEDIA?	CLEANING TECHNIQUE	PRICE IN LOTS OF ONE	OPTIONS
Computer-Link Corp.	1011	Magnetic Tapes	Two gemstone blades plus self-advancing wiping tissues. Independent cleaning/winding tension zones.	\$2,500	E-Z Load Cartridge, NAB hubs, Repair Location Footage Counter, Packing Wheel & BOT Stop, Tape Erase Feature, Multi-Cycle Clean, Physical Defect Scanner
	2000	Magnetic Tapes		\$10,000— \$12,500	Cleans and tests tapes 800, 1600, 6250 bpi.
	650	Disc Packs, 2316, 3316	Wet and dry cleaning capabilities in accordance with manufacturers specifications		Univac 8440
	660	Disc Packs, 3336, 336-11	"		
	665	Disc Packs, 1316, 2316, 3336, 3316-11	"		CDC, Calcomp, Burroughs, Univac
	670	Disc Cartridges 2315, 5440	"		Inspection capability
Data Devices International	Mark IIIA	Cleans Tape	Blade and Grid Cleaners with vacuum removal	\$ 2,350	Footage Counter
	Mark IV	Cleans Tape	"	2,895	Erase Station
	Mark X	Cleans Tape	"	3,795	Non-Standard Width
	Mark XX	Cleans Tape	"	5,995	NAB Hubs
	Century 22	Cleans & tests tape	"	10,000	Several
	Masteranalyst	Cleans & tests tape	"	15,000	Several
	Clean-Machine	Cleans disk cartridges	Presaturated, Factory mechanized cloth pads	995	
CMS-IV	Cleans & tests disk cartridges	"	2,150		
Innovative Computer Products	100	Philips Digital Cassette	Solution — Pads	\$ 295	
	300-TC	Disk Cartridge Type 5440	Solution — Pads	\$ 985	
	300-FC	Disk Cartridge Type 2315	Solution — Pads	\$ 985	
	400	Disk Cartridges Types 5440 and 2315	Solution — Pads	\$ 2,295	Inspection capability — both visual and instrumentation
Kybe Corp.	E-24 Mod VI	Computer Tape	Blade & tissue	\$ 2,850	
	TC-225	Computer Tape	Blade & tissue	2,350	
	ITC-150	Instrumentation Tape	Blade & tissue	4,900	
	VTC-160	Video Tape	Blade & tissue	5,400	
	CTC-300	Digital Cassettes	Blade & tissue	545	
	DP-30	Disk Packs	Wet & dry pads	4,395	
Randomex (Data Maintenance, Inc.)	500	Front and Top-Loading Cartridges	Inspects without disassembly of cartridge plastics	\$ 995	Complete
	600	ALL Disk Packs	Uses comb gauges for tolerance checks, and mirror towers for disc surface inspection	2,350	Complete
	515	Front-Loading Cartridges	Fully automatic machine cleaning, scrubs disc surfaces min. 220 times. Supplies cost: 7¢ per cartridge	2,700	Complete
	535	Top-Loading Cartridges	Identical to 515, immediately above	2,700	Complete
	235	6 & 11 High Packs	Fully automatic machine cleaning, scrubs disc surfaces min. 360 times. SUPPLIES COST: 10¢ per Pack.	3,100	Complete with brush assemblies
	335	All 6, 11 & 12 high Packs, plus Trident, HP 7920, & CDC Data Storage Modules	Identical to 235 above	4,700	Complete with 3 major Brush assys. Trident, DSM Brushes optional, extra
	435	All packs as with 335, plus Univac 8416 & 8418 packs.	Identical to 235 above	4,850	Trident, DSM brush assys. All others furnished.

Continued ▶

IF YOU DON'T SEE IT HERE,

ASK!

M1000/M2000 series 5-inch and 9-inch display modules. These highly reliable displays testify to the effectiveness of measured rather than calculated MTBF. Samples of every complete Motorola CRT display module are life-tested for a minimum of 10,000 hours at 55°C. Customers report some of our displays logging more than 40,000 hours and still going strong.

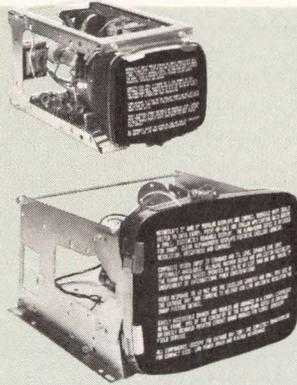

M3500 series 12-inch display modules in chassis or kit form (shown). Cost saving, plus no metal boundaries to inhibit your own layout.

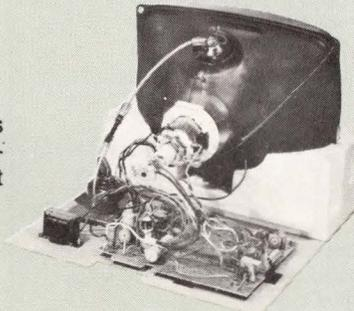

MD3000 series 12-inch display modules. Between the MD3000 and M3500 series, you can have your 12-inch display in any of several ways: chassis or kit, separate sync TTL level, composite video or direct drive inputs, choice of standard EIA phosphors, choice of scan frequencies, with or without anti-reflective faceplate.

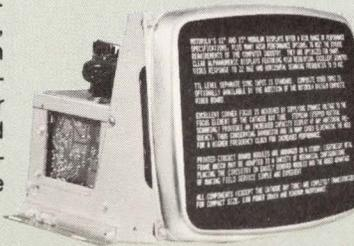

MD4000 series 15-inch display modules. Up to 3,440 upper and lower case characters in a 7 x 9 dot matrix. Every line is sharp . . . even in the corners. StepScan™ 22 MHz bandwidth and customer adjustable dynamic focus are standard in the MD3000 and MD4000 series. If looks on the screen are important—and when aren't they?—a Motorola display is what you want.

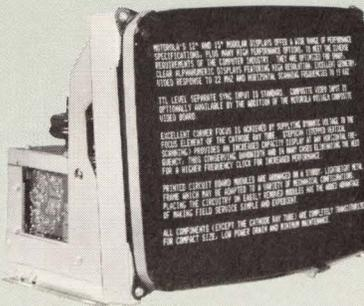

The M4408 15-inch module displays a full page horizontally (132 x 46) or vertically (96 x 66, shown). High character density and low cost, too—raster scan technique with standard TTL logic interface gives you economy twice: once in purchase price and again in design costs. A technology leader.

There's more. We make more than 65 different CRT display module variations. So the chances are that we already manufacture a CRT display module that fits your application.

But if we don't—and if your volume justifies it—we have the know-how and experience to design and build for you.

That's just one more area in which experience—our experience—can benefit you.

Call the sales office in your area:

- Sunnyvale, California (408) 744-1277
- Tustin, California (714) 838-5621
- West Chicago, Illinois (312) 231-4400
- Dallas, Texas (214) 233-2006
- Salem, New Hampshire (603) 898-5921
- Shrewsbury, New Jersey (201) 544-9541
- Baltimore, Maryland (301) 821-0062

Overseas, ask for International Sales Manager, West Chicago, Illinois (312) 231-4400
TWX: 910-230-3117

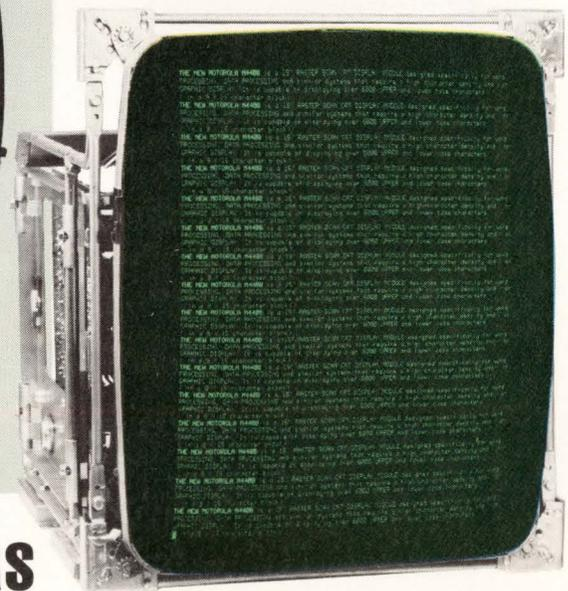

BENEFIT FROM EXPERIENCE . . . OURS



Display Systems 1155 Harvester Rd., West Chicago, IL 60185

Circle 56 on Reader Inquiry Card

MAGNETIC MEDIA MAINTENANCE PRODUCT SPECIFICATIONS

MODEL NO.	CLEANS WHICH MEDIA?	CLEANING TECHNIQUE	PRICE IN LOTS OF ONE	OPTIONS		
Recortex Inc.	CTE-501	½" mag tape, 9 track 800 or 1000 bpi	Self-sharpening vacuum cleaning grid	\$ 7,950	See price list.	
	CTE-502	½" mag tape, 9 track 800 and 1600 bpi	same	8,600		
	CTE-503	½" mag tape, 9 track 1600 and 6250 bpi	same	9,700		
	CTE-504	½" mag tape 7- and 9- track 800 and 1600 bpi	same	9,850		
The Texwipe Co.	TX801- Texpads	Magnetic Head & Disc Cleaner	Pre-saturated pad containing isopropyl alcohol and de-ionized water for removing contaminants from disc surfaces.	100/bx 13.00		
	TX300- Texsleeve	Magnetic Head & Disc Cleaner	Lint-free cotton sleeve for cleaning discs & heads.	144/bx 30.00		
	TX106- "Freon" TP-35 Solvent Cleaner	Selective Solvent for cleaning critical com- ponents of the tape path.	Spray or non-aerosol filter assembly. Attacks contaminating soil and particulate matter.	12 cans/bx 42.00		
	TX335- Texwipe	For every type of wiping application	Lint-free, static-free, containing no added binders to affect surfaces being cleaned	600/bx 19.00		
	TX700- Foam Swabs	For cleaning components & inaccessible areas.	Highly absorbent, Urethane foam covered swabs that will not lint.	50/bx 6.50		
	TX600- Microduster	For cleaning remote interior areas.	Pinpoints a fine stream of com- pressed gas (dichlorodifluoro- methane) CCL ₂ F ₂ to wash away dirt.	1 19.00		
	TX601 Swinny Filter Assembly	For use where strict contamination control is essential.	Filters the gas for maximum purity.	1 15.00		
	TX610- Discover Cartridge Bag	Protective bag for discs	Prevents contamination from reaching disc surfaces.	1 2.50		
	System 316 Disc pack (cleaner/ inspector/ tester.)	1316 & 2316 type packs	Visual & mechanical inspection of out-of-tolerance conditions, inspects for scratches, edge damage & burned oxide, warpage & dents.	10 mirror 2250.00		
	System 336 (Disc cleaner cleaner/ tester/ inspector)	3336 & 3336-11 type packs	"	11 mirror 2250		
	System 340 (316 & 336 combined)	Every type pack	"	1 3350		
	System 315 Disc Cart- ridge Cleaner	Cleans both front & top loading cartridges.	Disc can be jogged into position for single area cleaning. Ideal for controlled manual cleaning.	1 995		
	System 315X Disc Cart- ridge Cleaner/ Inspector	Cleans both front & top loading cartridges.	Same as 315 with inspection capability.	1 295		
						Opt. acces- sories for the above

Dataram

Dynus Disc/Tape Controllers Cost You Less To Use!

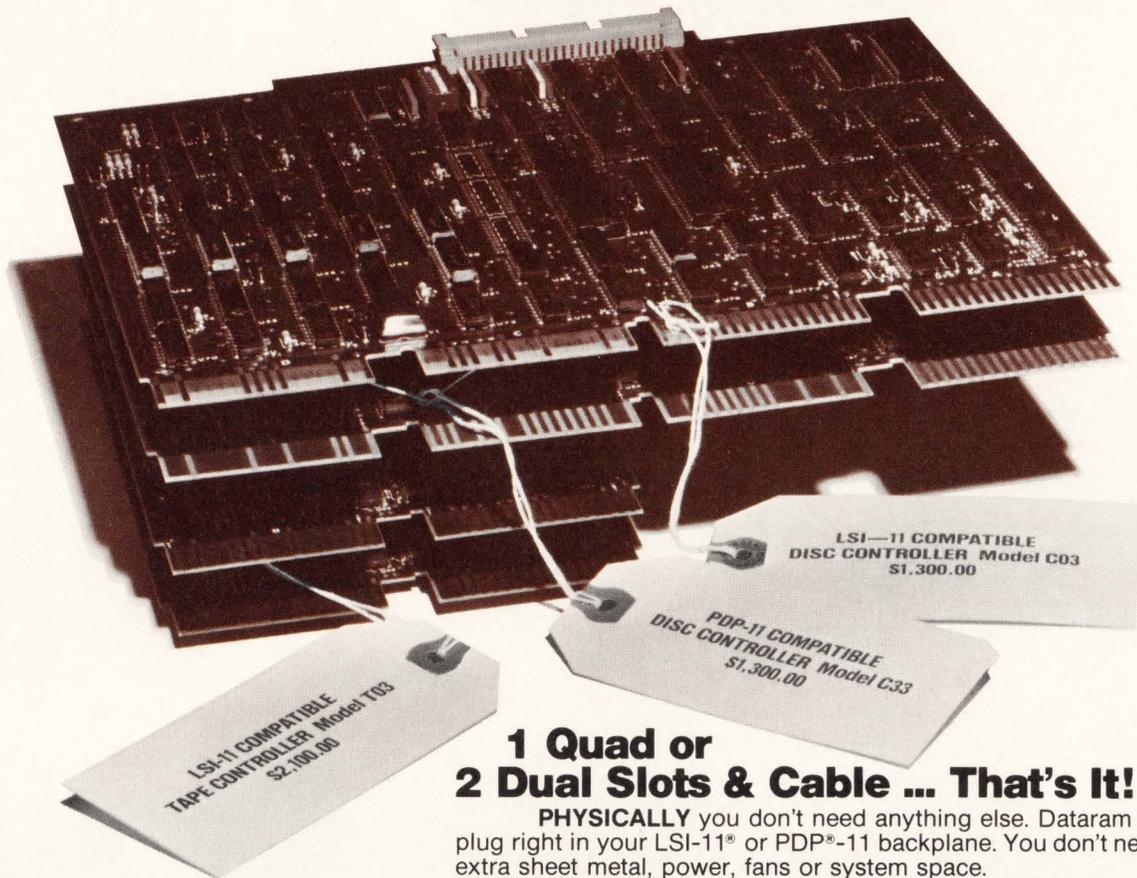

1 Quad or 2 Dual Slots & Cable ... That's It!

PHYSICALLY you don't need anything else. Dataram Controllers plug right in your LSI-11® or PDP®-11 backplane. You don't need, or pay for, extra sheet metal, power, fans or system space.

ELECTRICALLY you don't need anything else. Dataram Controllers simply become a part of your computer.

OPERATIONALLY you don't need anything else. Dataram Controllers are totally LSI-11 or PDP-11 software compatible — even diagnostics! They work with all independent RK05 or TU10 equivalents... there are no design subtleties that can *lock* you to one manufacturer's product. Dataram Controllers ensure that *you stay in control of your product.*

FINANCIALLY the cost to use Dataram Controllers is all up front. You won't get trapped by some single-source "bargain" unit with a non-standard format requiring additional software, limiting your operational flexibility or increasing your on-going costs for one-of-a-kind disc paks, etc., etc.

PHILOSOPHICALLY we make no promises, we just perform. Delivery is within 30 days . . . not "someday." Dataram LSI-11 or PDP-11 plug-in compatible Disc/Tape Controllers are real now ... not "soon to be" or "almost."

CONTACT Dataram and get the facts on the LSI-11 or PDP-11 Disc or Tape Controller that *Keeps You In Control . . . And Costs You Less To Use!*

*Qty. 50 -

**Dynus . . .
now part of Dataram**



**DATARAM
CORPORATION**

PRINCETON-HIGHTSTOWN ROAD
CRANBURY, NEW JERSEY 08512
TEL:609-799-0071 TWX:510-685-2542

LSI-11 and PDP are registered trademarks of Digital Equipment Corporation.

Dataram Corporation • Princeton-Hightstown Road • Cranbury, NJ 08512

- Please send complete details on Dataram Disc/Tape Controllers.
- Please have your sales representative call.

NAME _____ TITLE _____ PHONE/EXT. _____
 COMPANY _____ DEPT./DIV. _____
 ADDRESS _____
 CITY _____ STATE _____ ZIP _____

Circle 57 on Reader Inquiry Card

2) **SOLVENTS.** The cleaning agents used should be carefully selected. A variety of solutions, basically detergents, regardless of costs or claims, will leave residue. A safe, selective solvent that leaves little or no residue, and has no adverse effects on materials of construction belongs in the computer room. Freon 113 blended with isopropyl alcohol is highly recommended for this purpose.

3) **SWABS.** Urethane foam covered swabs are recommended in cleaning small critical components such as recording heads and tape guides. A foam covering prevents the swab from leaving lint fibers on critical areas. Do not, under any circumstances, use an uncovered cotton swab of the consumer variety. Remember, cleaning areas with inappropriate tools and materials actually produces contamination, and is worse than not cleaning at all.

4) **MICRO DUSTER.** A compressed

gas dusting device is the best method for cleaning remote or inaccessible areas. Compressed air is commonly available; however, it is unclean. The best medium for this cleaning process is dichlorodifluoromethane CCL_2F_2 . This agent is non-corrosive, non-flammable and is inert to all materials found in discs and data processing hardware. This method of cleaning removes contamination without abrading or scratching sensitive surfaces.

5) **PRE-SATURATED PADS.** A pad saturated with solvents and cleaning agents, a convenient put-up for in-house maintenance, are effective cleaning implements for terminals and R/W heads. Two types of pads are available; both are hermetically sealed in foil packets and are non-contaminating and lint-free.

6) **DISC PACK AND DISC CARTRIDGE CLEANERS/INSPECTORS.** Instrumentation is available for in-

house, on-site, testing, inspection and cleaning of standard discs and cartridges. These systems measure discs to detect and identify warpage or out-of-tolerance conditions. They can be used for visual inspection of disc surfaces for the detection of dirt, scratches, head crash damage or loading marks. Regular use of cleaner/inspectors reduce the need for costly corrective maintenance.

Since contamination is a major source of malfunction, the mechanical condition of peripherals and components of a minicomputer system must be kept under continual surveillance. Cleaning on a catch-as-catch can basis is worse than not cleaning at all. Since conditions in a minicomputer environment are so conducive for contamination build-up, a regular schedule in in-house preventive maintenance should be instituted before the costly results of downtime occur.

Use CTEs to Test, Clean (Re)Wind TAPES

"We are a major supplier of such equipment for computer tape and for all other widths of bulk tape to large EDP users and to all the major tape manufacturers of the world," states R.R. Troxell, Program Manager for Recortec, Inc.

"Our Computer Tape Evaluator is an off-line tape handler for testing, cleaning and winding/rewinding computer tapes. As an Evaluator, CTE helps: (1) minimize wasted computer time by selecting error-free tape for critical applications, (2) maximize tape life through periodic testing to determine which tapes need to be replaced and which tapes can be reused with continued assurance of reliable performance, and (3) establish quality assurance by identifying error-prone tapes in the library, and evaluating new tapes before they are utilized.

"As a Cleaner, CTE removes loose oxide and debris from both tape sides to: (1) reduce wasted computer time, (2) prolong useful tape life and (3) extend head life. As a Winder/Rewinder, CTE provides a uniformly packed reel with smooth edges to prevent cinching and edge wrinkling during handling and storage."

DISK PACKS NEED CLEANING

C. Paul Davis, *President*
Innovative Computer Products

Historically, computer manufacturers have taken the position with disk packs that absolutely no maintenance is required — thus no cleaning. Since disk packs were used in environmentally controlled areas, each pack had its own internal air filter, and the heads never touched the surface of the platter, there were no logical reasons to attempt to clean disk media — or so the engineers said. The only cleaning that was tolerated was the cleaning of a read/write head by a field engineer if a problem occurred. Recently, however, disk packs have experienced the same type of development as that of magnetic tape — increased speeds, increased packing densities, more tracks per inch, heads closer to the surface of the platter and so on. These changing parameters led to a familiar phenomenon: increased errors, track reassignments, data checks, and that horrible catastrophe called a "Head Crash." Peripheral and computer manufacturers lately have not been as vehement in their objection to disk surface cleaning, but rather are now looking for the right type of cleaning for disk packs and cartridges!



ICP's Model 300 Disk Cartridge Cleaner for front loading cartridges.



Innovative Computer Products Model 400 Disk Cartridge Inspector Cleaner for either front load or top loading cartridges.

There is no Great Debate

Joseph M. Ludka, *President*
Randomex, Inc.

Six years ago, there was a debate regarding the need for periodic disk maintenance. However, the issue, in our estimation, was resolved many years ago. Today, it is no longer a question of whether to maintain disks, but HOW OFTEN. Randomex customers include more than 95% of the industry's main-frame, drive, head and pack manufacturers.

The debate may involve the methods used, but the industry's conclusion a long time ago was that, if done properly, disk maintenance was necessary and highly beneficial.

Randomex has just committed to an acquisition of Data Maintenance, Inc., a disk maintenance service corporation with offices in most major U.S. cities and nine foreign countries. To people making their living in these areas, there is no debate.



Cartridges are inspected with the DMI Model 500 Disk Cartridge Inspector (w/5440-type cartridge). Twin Optical Probes permit illuminated, magnified inspection of both disc surfaces. Trouble spots literally leap out.

Perhaps this diminishing objection by manufacturers to the concept of cleaning rotating disk surfaces is due to the success of the new, commercially available disk cartridge cleaners. Removable disk cartridges, particularly the front load and top load, single platter units, use the same technology as the ten platter, high performance disk packs. The main differences in the cartridge versus the packs, however, are: (1) the cartridges are used on small systems that very rarely are found in environmentally controlled areas, and (2) the cartridge drives do not contain their own air filtering system and are usually handled by office personnel rather than trained computer operators.

What these differences lead to are much higher incidents of track reassignments, data errors and actual head crashes. For a disk user, a head crash is the most serious problem that can be encountered. Whereas with magnetic tape, the recording head is in constant contact with the tape, the most that can occur is that contaminants can cause data not to be written or read and possibly lost. However, with disk technology, a R/W head "flies" above the surface of a disk platter on

a cushion of air at a height of a few micro-inches. If a particle of contamination is encountered, not only is the data lost, but the aero-dynamics of the disk/head relationship is interrupted and the head bounces up and comes

down causing what is called a "Touch Down" or "Crash." The precision and difficulties of this technology have been compared to a 747 flying two feet off the ground at a speed of 600 miles per hour — difficult, to say the least. DD

BUYER'S GUIDE

To help you get further information on the products discussed in the report and chart, here is a partial list of manufacturers. We thank them for answering our questions and providing the photos and data.

Circle the appropriate number on the Reader Inquiry Card, and you will receive additional information from the manufacturers.

Computer-Link Corp.
14 Cambridge St.
Burlington, MA 01803
(617) 272-7400 **Circle 151**

Data Devices International
20235 Bahama St.
Chatsworth, CA 91311
(213) 998-2900 **Circle 152**

Innovative Computer Products
19360 Oxnard St.
Tarzana, CA 91356
(213) 996-4911 **Circle 153**

Kybe Corp.
132 Calvary St.
Waltham, MA 02154
(617) 899-0012 **Circle 154**

Randomex, Inc.
27303 Warrior Dr.
Rancho Palos Verdes, CA 90274
(213) 377-9887 **Circle 155**

Recortek, Inc.
777 Palomar Ave.
Sunnyvale, CA 94086
(408) 735-8821 **Circle 156**

The Texwipe Company
51 Prospect Pl.
Hillsdale, NJ 07642
(201) 664-0555 **Circle 157**

DISSPLA[®] Software

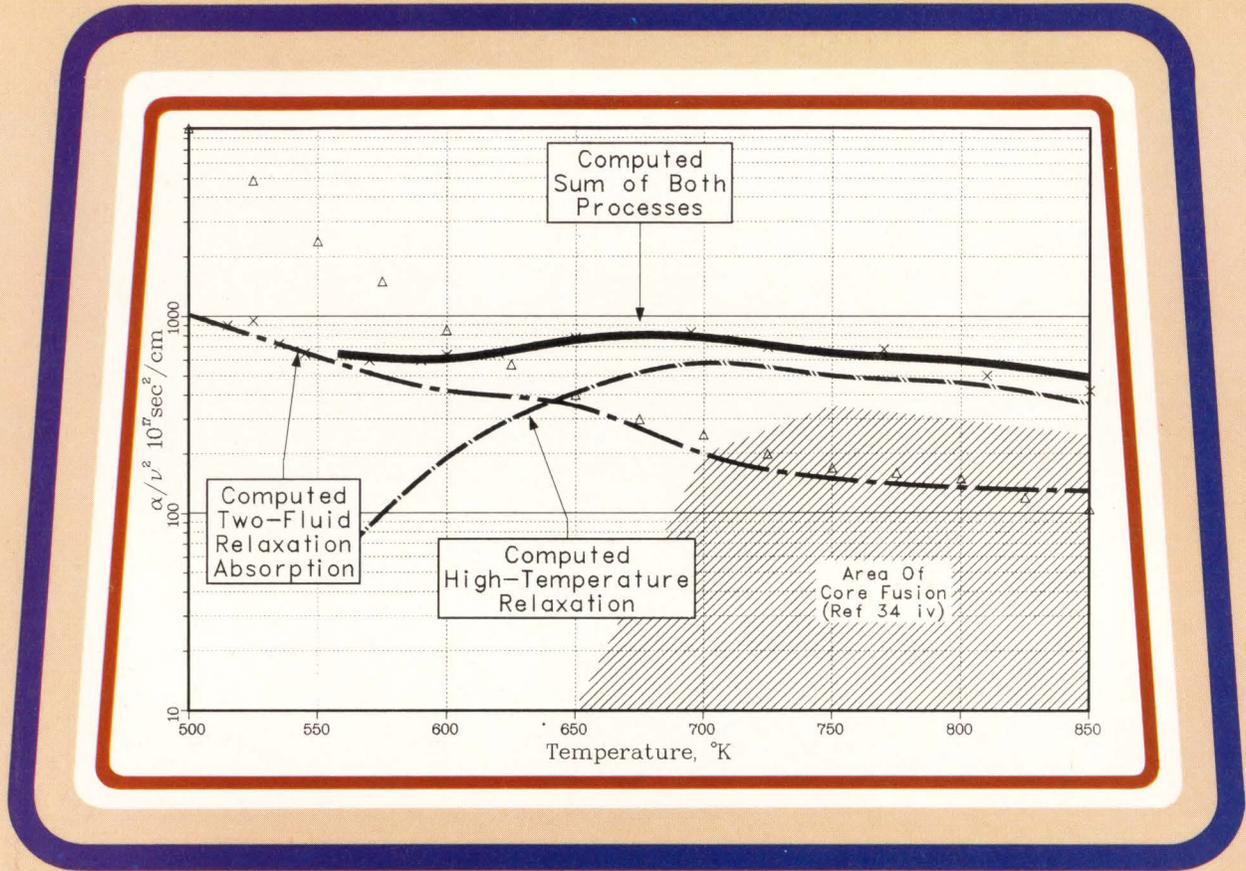

There Is No Better Way To Present Your Data

HIGH QUALITY GRAPHICS

DISSPLA software puts truly professional graphics within reach. No longer is art department touch-up necessary. Total flexibility permits tailoring of XY-diagrams, bar charts, pie charts, maps, 3-D plots, and annotation to all special needs. Graphics for publications, presentations, management reports and internal documentation can be produced quickly and correctly. At last, sophisticated presentation methods can do full justice to advanced analysis techniques.

DEVICE INDEPENDENT

DISSPLA can drive any graphics device whatsoever; our users have Broomall, CalComp, Gerber, Hewlett Packard, Houston Instrument, Xynetics and Zeta pen plotters; Gould, Varian and Versatec electrostatic plotters; DatagraphiX, DICOMED, III, Singer and 3M microfilm recorders; Chromatics, Computek, Tektronix, and Vector General CRT's; and many others. If it can draw a straight line, DISSPLA can plot on it.

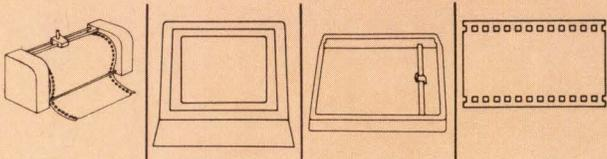

MACHINE INDEPENDENT FORTRAN LIBRARY

DISSPLA is currently operating on all large-scale Amdahl, Burroughs, CDC, DEC, Hewlett Packard, Honeywell, IBM, TI, UNIVAC and XDS systems, plus the Harris midcomputer. The DISSPLA routines may be called from FORTRAN, PL/I, COBOL, ALGOL, etc.

EASY TO USE

High level commands with easily remembered mnemonics, sensible defaults, minimal parameter strings, and clear diagnostics make this available to any user, not only graphics experts. Extensive documentation and user training is provided.

DISSPLA[®]

Display Integrated Software System and Plotting Language
A proprietary software product of ISSCO

ISSCO[®]

Integrated Software Systems Corporation

4186 Sorrento Valley Blvd., San Diego, CA 92121 (714) 452-0170

In Washington, D.C.:
Applied Urbanetics, Inc.
1701 K. St., NW
Washington, D.C. 20006
Phone (202) 331-1800

In Europe:
Repko b.v.
van Blankenburgstraat 58
The Hague, Holland
Phone: 070-608425

ADVERTISER'S INDEX

ABLE COMPUTER TECHNOLOGY	C-2
ADDMASTER	6
ADTECH POWER	70-71, 73
ADVANCED ELECTRONICS DESIGN	75, 77
ANDERSON REPORT	15, 16
AUDIOTRONICS/Video Display Div.	34
AYDIN CONTROLS	51
CHARLES RIVER DATA SYSTEMS	35
DATARAM	91
DATASYSTEMS	74
DE ANZA	11
DECITEK Div./Jamesbury	63
DIGITAL DESIGN MAGAZINE	76
DIGITAL GRAPHIC SYSTEMS	74
DIGITRAN	21
DISC INSTRUMENTS	24
EECO	47
ELECTRORENT	81, 82
EPSON AMERICA	25
FUTUREDATA COMPUTER	1
GENISCO COMPUTERS	53
GRINNELL SYSTEMS	4
HOUSTON INSTRUMENTS	33
HYCOM	95
INTERDESIGN	17
INTERFACE '79	26-27
ISSCO	94
C. ITOH ELECTRONICS	23
KENNEDY CO.	C-4
KEYTRONIC	83
MACROLINK	6
MEGATEK	43
MEMODYNE	68
M.D.B. SYSTEMS	79
MOHAWK DATA SCIENCES	67
MOTOROLA/DISPLAY SYSTEMS	89
NEW ENGLAND RECRUITERS	95
OK MACHINE & TOOL	65
PERKIN-ELMER	2-3
PERSONAL COMPUTING MAGAZINE	80
PRINTRONIX	13
RAYMOND ENGINEERING	72
RIANDA ELECTRONIC	78
SIGNETICS/Corporate Div.	48-49
SOROC	55
SYSTEM INDUSTRIES	C-3
SYSTEMS RESEARCH LABORATORIES	58
TANDBERG DATA	9
TEC	39
TELETYPE	69
THOMSON INDUSTRIES	76
WATKINS-JOHNSON	41
WESPERLINE	29
WESTERN PERIPHERALS	7
WILSON LABORATORIES	19
WORLDWIDE FINANCE EXCHANGE	31
XYLOGICS	57

SALES OFFICES

NEW ENGLAND,
MID-ATLANTIC and
SOUTHERN STATES

David Boals
(516) 872-9550
(201) 793-3060
92 S. Central Ave.
Valley Stream, NY 11580

MIDWEST and TEXAS

Hank Bean
(312) 475-7173
2633 Hillside Lane
Evanston, IL 60201

WESTERN STATES

David Chew
(213) 478-3017
924 Westwood Blvd.
Suite 610
Los Angeles, CA 90024

JAPAN

Hiro H. Irie
(03) 311-1746
International Business
Corporation
11-8 Narita-Higashi
1-chome
Suginami-ku
Tokyo 160

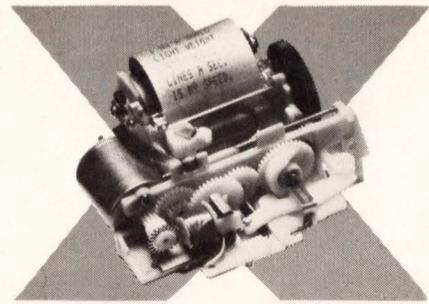

Small, portable printer.

The DC-1206B prints 12 characters/line nominal, but is capable of 16 columns. It is sized for portable, hand-held applications with 1.7" H x 3.2" W x 3.7" D and 5.3 ounces. It prints 5 lines/sec. on 1.4" paper and is only \$49 in 100 quantity.

Call or write HYCOM, 16841 Armstrong Ave., Irvine, CA 92714 — (714) 557-5252

HYCOM

Circle 60 on Reader Inquiry Card

SENIOR LOGIC DESIGN ENGINEER

THE COMPANY: Fastest growing computer based systems manufacturer among the Fortune 1000. 1978 sales in excess of \$150 million.

RESPONSIBILITIES: Reporting to the Hardware Design Manager. Will function as senior technical contributor and project leader on a variety of subsystem designs including disc controllers, data terminals, graphic displays and distributed networks.

REQUIREMENTS: Several years experience in the design/development of mini/micro based systems. Software development experience a plus, BS degree necessary.

GROWTH: Company has promoted over 50% of its employees in the last 4 years.

COMPENSATION: High 20's to mid 30's. Outstanding benefits.

Interested parties are invited to make inquiries regarding the above and other opportunities currently available. Strict confidence assured.

CONTACT: Dave Adams, (617) 246-2815, N.E. Recruiters, 6 Lakeside Office Park, Wakefield, MA 01880.

Collect calls accepted. All fees, interviewing and relocation expenses assumed by the company.

T.J. Michel
Santek, Inc., Hollywood, FL

The Changing Digital World

It may shock most digital engineers that the simple circuitry with which they implement their systems is changing rapidly in the face of new developments in IC technology. It is not so much that circuitry itself is changing, but the affect on other devices is becoming more pronounced. Specifically, we are talking about conductors and their relationships to the ICs that they interconnect and the PC board substrate upon which the ICs are mounted. In the past, conductors were characterized in general terms as specific resistances with low ohmic values that were fairly predictable (for instance, two milliohms per square). This has been acceptable for use in both analog and digital circuitry, regardless of the level of sophistication employed — be it TTL, ECL, or CMOS. However, as we see speed and power products go down, propagation of pulsed wave forms becomes more critical. Rise time, overshoot and ringing must be controlled. The resistances of inner-connect conductors can no longer be characterized completely and elegantly in terms of simple ohmic values. It's time engineers considered treating the circuitry in these digital PC boards more as transmission lines and think of them more in terms of transmission line and propagation phenomena than simple DC connectors that route a voltage from point A to point B. Parameters such as distributed R's, distributed C's, and L's, must be dealt with in DC square wave pulse manipulation for digital technology.

Distributed resistances, or more appropriately their reciprocals conductance-leakage, are important to characterize for three reasons. First, uncontrolled current leakages eat power, place higher demands on power supplies and increase device dissipation. Second, they appear as additional loads to high impedance devices, causing mismatch and signal dropouts. Third, they cause spurious signals and false triggering when found between power rails and signal plains.

Distributed capacitance has a dramatic affect on the rise time of subnanosecond pulses that have to be propagated with minimum overshoot and minimum undershoot. Not only can capacitance distort the wave shape by rounding-off corners and extending rise time, but can cause rather drastic propagation delays. The problem is two-fold: first, there is pulse distortion and its affect on the device which must receive it; and second, if the propagation delay becomes too great and starts to approach clock rates, desynchronization occurs within the circuit.

Problems of system failure due to circuit failure are not always resolved by automatic test equipment. In many cases the automatic test equipment will indicate that a stuffed printed circuit board is inoperative and can localize a specific quadrant of disfunction, but that is as far as

it goes. When this kind of problem crops up it is in many cases caused by either distributed current leakage or a high resistance inter-layer leak. ATE is not able to detect these problems either in the bare or loaded board phase.

Conventional ATE will detect shorts (resistances in the 10 ohm range or less) or opens (resistances in the 1000 megohm range), but has no way of dealing with resistances of 1×10^{12} through 1×10^{17} ohms. It is in these regions where changes in levels can cause circuit malfunction.

These malfunctions in high impedance analog boards look like: (1) Excessive losses; (2) Low Q circuits; (3) Circuit loading, and (4) Signal dropouts. On digital boards these problems arise as: (1) Cross talk; (2) Glitches due to excessive overshoot; (3) Phase desynchronization, and (4) Signal dropout.

A PC board is really an array of resistors. The resistors between conductor A and B are smaller in value than the resistors between B and C because of the spacing of the lands. Essentially these resistors are made up of the PC board material, whether it is G-10 glass epoxy or XXXP phenolic.

Five years ago, the small interconductor capacitors could be easily ignored because of conductor spacing and insulation factors. Within the limits of modern technology, however, the use of 15x15x15 mil spacing is common; and in some cases, 10x10x10 mil spacing is used extensively. Within the more advanced companies, spacing factors of 6x6x6 mils are being investigated. That means only 0.006 in. of insulation material exists between each conductor which, in turn, is only 0.006 in. wide. These dimensions now generate problems because we are approaching capacitor dielectric thicknesses which are very small coupled to dielectric constants which are medium to large. This can generate substantial capacitors in a very short run of interconnect material. The same argument can be applied to distributed inductances: the smaller the equivalent wire gauge, the higher the inductance terms and, therefore, the more wave distortion and time delay is created.

Now, we are not advocating that we treat each one of these circuit paths as a specific transmission line case. Our point is that we need to start being more conscious of propagation delay problems, phase problems, and wave distortion due to distributed R's, C's and L's. We need to treat the PC board as a component, not as a orphan child of the manufacturing process. We are fast reaching the point where the computer circuit sophistication and speed is outstepping the bounds of conventional PC board technology and theory. Worse, technology is outrunning the ability of electronics to formulate a support philosophy to deal with it.

11/70 USERS:

We'll Give You 50% More Disk Storage than DEC for About Half the Price.

System Industries new RH-70 Emulator can give you up to 2,400 MBytes of disk storage with 8 spindles on-line.

That's 100 MBytes more per drive than you'd get from DEC's RP06. Which you'd spend almost twice as much for.

Our fully transparent software increases those savings by putting the RH-70 to work immediately—without additional programming.

And your computer never has to go off-line.

By adding our RH-70 you'll get a large capacity, high performance disk storage system for non-stop operations with total system integrity. And cost per byte is low enough to keep those savings growing.

The RH-70 is built to keep running too. Just like the 6,000 other disk systems we've installed in the last nine years.

Its reliability is backed by the System Industries commitment to on-time delivery, total software support, and quick response to customer needs.

So let us help the computer you bought from "our friends in Maynard" save you money.

Contact the System Industries sales/service office nearest you today.

Or clip the coupon for full details on the best price/performance disk system you can buy.

System Industries
an equal opportunity employer

In United States: SYSTEM INDUSTRIES
525 Oakmead Parkway, P.O. Box 9025,
Sunnyvale, CA 94086, (408) 732-1650
Telex: 346-459

In Europe: SYSTEM INDUSTRIES U.K.
System House, Guildford Road, Woking,
Surrey, GU33 7QQ, England, (04862) 5077
Telex: 859-124



I'm ready to start saving on my disk storage. Please rush full information.

Name _____ Position _____

Company _____ Address _____

City _____ State _____ Zip _____

I want to start saving money today. Please have an applications specialist phone me at:

() _____ ext. _____

DD279

Circle 2 on Reader Inquiry Card

KENNEDY SERIES 5300 DISK DRIVES

Series 5300 drives are fixed media, high performance units utilizing advanced Winchester disk technology.

Available in one, two, or three platter versions, the unformatted data capacity can be as high as 70M bytes—all in 7" of rack space.

Track density of 300 Tpi is made possible by prewritten servo tracks utilizing one disk surface, thus assuring accurate head alignment under all circumstances. High data density results from use of advanced media and write compensated MFM recording.

Maximum seek time is 70 msec, rotational speed, 3000 rpm, and data rate — 1.0 MB/sec.

The tightly sealed disk compartment allows Series 5300 drives to be used in environments unsuitable for conventional drives.

Other Series 5300 features include: NRZ-MFM data encode/decode circuits; daisy chaining of up to 4 drives; address mark detection; built-in power supply; small, easily replaced circuit cards and a standard interface.

Series 5300 is sophisticated in concept, yet like all Kennedy products, is simple in design for greater reliability, improved performance and lower cost.

KENNEDY CO.

540 W. WOODBURY RD., ALTADENA, CALIF. 91001
(213) 798-0953



KENNEDY · QUALITY · COUNT ON IT

Circle 3 on Reader Inquiry Card