



VAX

DECShell

JULY ■ 1988

VOL. 7, NO. 7 ■ \$4.00

DEC PROFESSIONAL

A PROFESSIONAL PRESS PUBLICATION

- SQL For Portability And Integration
- VMS/UNIX Data Sharing Techniques
- TCP/IP For Network Services

UNIX is a trademark of Bell Laboratories.

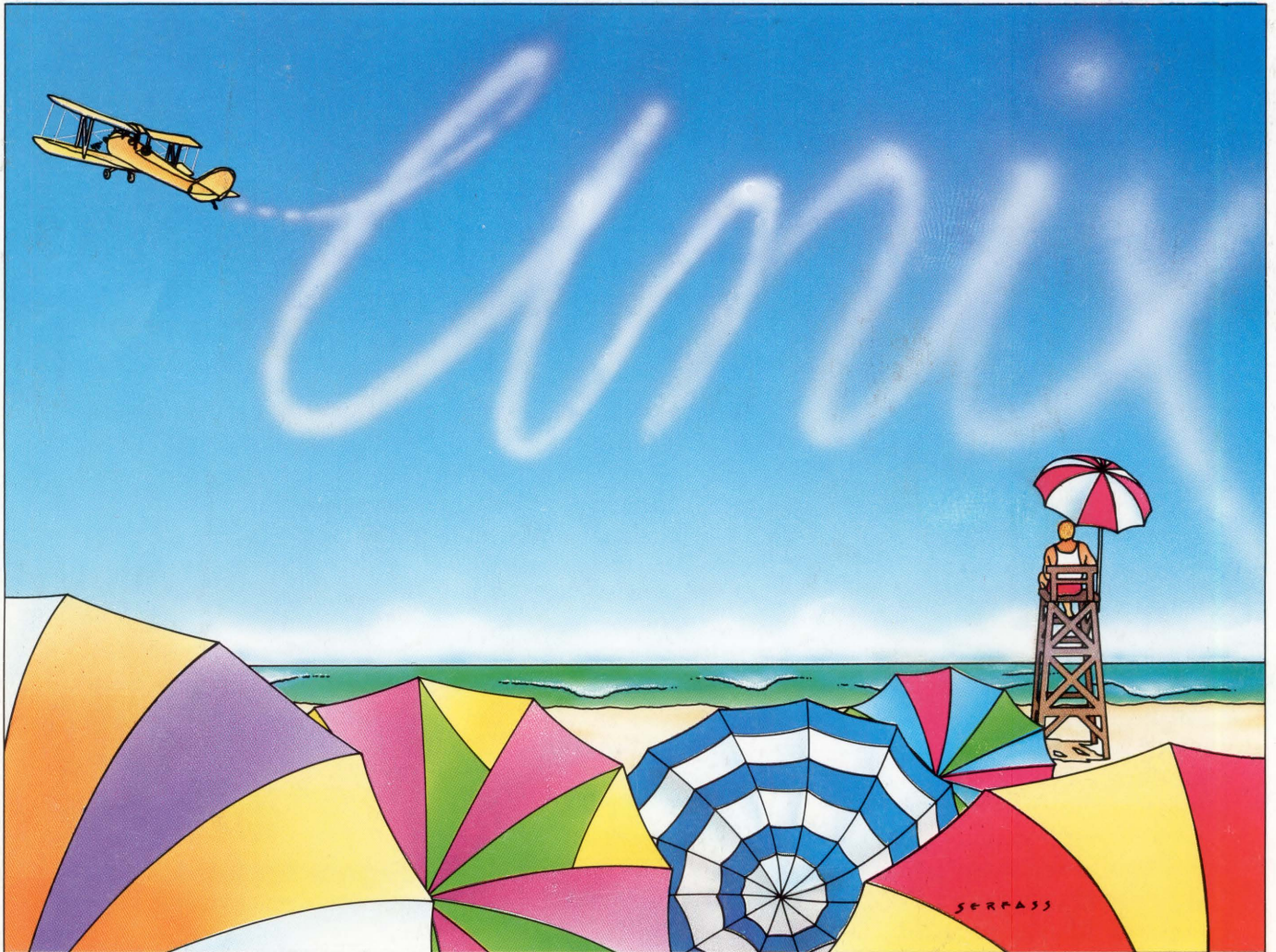

Blue Skies For UNIX™

This magazine is not sponsored or approved by or connected in any way with Digital Equipment Corporation. "DEC" is a registered trademark of Digital Equipment Corporation. Digital Equipment Corporation is the owner of the trademark "DEC" and is the source of all "DEC" products.



The Word At Microsoft Is SMARTSTAR Excels.

"For me, an outstanding feature of SMARTSTAR® is its ability to integrate with third party software as well as with applications developed in host languages. We use it as a transparent frontend facility to our MAXCIM (ASK) based manufacturing software," says Microsoft® Lead Development Analyst Greg Nelson. He also notes that the addition of scrolling regions (master/detail record processing) extends SMARTSTAR into the production applications development environment. In addition, Mr. Nelson states, "Signal Technology support is amazing. There is always a competent person available with a timely response."

SMARTSTAR is SQL-based 4GL application development and data management software designed exclusively for VAX/VMS. It is an ideal interface to Rdb and RMS, and it implements the Digital Standard Relational Interface. New features include functional menus, scrolling regions and windows. VAX/VMS users committed to Digital standards find that SMARTSTAR is a must.

As a leading VAX/VMS 3rd party application development system, SMARTSTAR is typical of the Signal Technology product line. PACS PLUS® resource management software is installed at more VAX sites than all competitive products combined. ILS®, with more

than 2,000 installations in 38 countries, is the world standard signal processing software. And no software developer is more committed to customer support and satisfaction than STI.

For details or a SMARTSTAR demonstration . . . or for information on any STI product, please write or call toll-free: 800-235-5787.



Signal Technology Inc

CIRCLE 275 ON READER CARD

5951 Encina Road
Goleta, CA 93117 USA
(805) 683-3771
FAX (805) 967-0871
TWX/Telex 910-334-3471

VAX and VMS are trademarks of Digital Equipment Corporation.
MAXCIM is a trademark of NCA Corporation. Microsoft is a trademark of Microsoft Corporation.
Atlanta Boston Chicago Dallas Los Angeles New York Philadelphia San Francisco Washington, D.C.

digital™ Cooperative
Marketing
Program
DPRA07/88



Closer to Genius

Introducing PowerHouse PC™, the most powerful 4GL for serious application development on a personal computer.

PowerHouse PC delivers more power than any other PC application development product. It gives you OS/2™ performance and integrated communications. And it gives you all of this — today.

PowerHouse now lets you prototype and build serious business applications on your PC in addition to HP, Digital and DG mid-range computers. The simplicity of one language across architectures gives you the flexibility of choosing the production environment that best suits your needs.

Use PowerHouse PC as a *development workstation* to develop applications for your mini, as a *host extension* to offload processing, or for *stand-alone* applications. Complete with a communications facility, PowerHouse PC makes the most of your resources by allowing you to share applications and data between architectures. What makes PowerHouse PC even smarter is that it runs under both *DOS and OS/2*.

When you're ready for serious application development on a personal computer, you're ready for PowerHouse PC.

Call Cognos direct, 1-800-4-COGNOS
In Canada, 1-800-267-2777

COGNOS

OS/2 is a trademark of International Business Machines Corporation. The Cognos logo and PowerHouse are registered trademarks of Cognos Incorporated. PowerHouse PC is a Cognos trademark.

Cognos Corporation, 2 Corporate Place, 1-95, Peabody, MA, USA 01960, (800) 4-COGNOS. Cognos Incorporated, 3755 Riverside Drive, P.O. Box 9707, Ottawa, Ontario, Canada, K1G 3Z4, (613) 738-1440. Telex: 053-3836. Cognos Limited, Westerly Point, Market Street, Bracknell, Berkshire RG12 1QB, United Kingdom, National (0344) 486668, International +44 344 486668, Telex: 846337 Cognos G.

CIRCLE 108 ON READER CARD

Conquer the Connectivity Challenge



The Challenge

If you're of the opinion that networking lots of PCs, printers, modems and host computers together has to be complicated and expensive, we'd like to change that opinion.

Presenting SwitchLAN

SwitchLAN is a simple low-cost network. It provides "hot-key" File Transfer, Terminal Emulation and Printer Sharing at a cost of about \$150 per PC.

Easy Does It

Installing SwitchLAN is a snap. It uses telephone type twisted-pair wiring and the serial COM port already in your PCs. You don't need to buy expensive network servers, install network boards in every PC, or struggle with coax cable.

Using SwitchLAN is as easy as installing it. Extensive help and pull-down menus are provided so people don't have to be network gurus to use it.

Challenge Us

Don't take our word for it. Call for more information or a free demo disk. With SwitchLAN you can turn a Connectivity Challenge into Child's Play.

Call 1-800-328-2729

In Florida: 305-255-3500

Equinox Systems Inc.
14260 S.W. 119 Avenue
Miami, FL. 33186

CIRCLE 122 ON READER CARD

EQUINOX

Simply Better Networks
DEC PROFESSIONAL JULY 1988

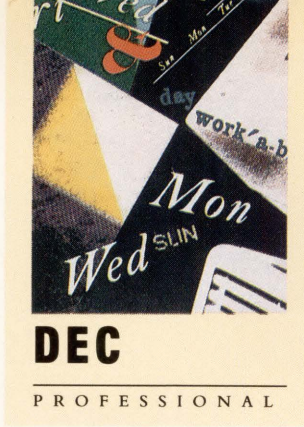

C CONTENTS

JULY 1988

VOL. 7, NO. 7

UNIX

38 DATA SHARING IN A VMS/UNIX ENVIRONMENT

by Robert W. Taylor, Ph.D.

A look at various types of data sharing techniques.

48 A BETTER UNIX FOR THE PDP-11

by Donnalyn Frey

The 2.10BSD UNIX operating system offers enhancements over 2.9BSD.

52 SQL FOR PORTABILITY AND INTEGRATION

by Scott Kitayama

Structured Query Language provides a common language to access relational databases and offers portability for applications and data.

56 DEC/SHELL

by Lori A. Snyder

An alternative UNIX environment.

ARTICLES

64 PRINTERS: IMAGEN-ATION

by David B. Miller

Imagen Corporation's ImageServer XP series printers combine flexibility, compatibility, functionality and speed in one package.

72 CASE: EXCELERATOR IN THE FAST LANE

by David B. Miller

Index Technology's Exceleator CASE product helps system analysts design and implement projects at light speed.



The lab seal indicates that the product reviewed has been tested by one of our experts in our Laboratory and Testing Center.

ON THE COVER:

This month's cover is the work of Pennsylvania-based airbrush artist Jim Serfass.

Continued on page 4.

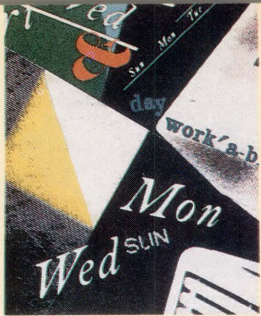

CONTENTS

Continued from page 3.

DEPARTMENTS & COLUMNS

Publisher

by Carl B. Marbach
UNIX Wars.....10

Editorial

by Dave Mallery
Survival In The 1990s.....14

Let's C Now

by Rex Jaeschke
Token Recognition82

RSX Clinic

by James A. McGlinchey90

X

by Evan Birkhead
X11 Toolkit Extensions.....92

Managing Your MICROVAX

by David W. Bynon
Capacity Planning And System Design,
Part 298

Networking Editor

by Bill Hancock
TCP/IP For Network Services102

Cluster Chronicles

by Dave Mallery
Hardware Connection Considerations.....110

DCL Dialogue

by Kevin G. Barkes
Errors, Non-Errors and Errata114

Standards

by Rex Jaeschke
Identifiers In Function Prototypes.....118

Field Service

by Ron Levine
DEC's After Your Service \$\$\$ Too120

From The Lab

Requiem.....128
by Dave Mallery

Sigma's MICROVAX Expansion Box
by Philip A. Naecker.....130

CompuServe Data's 1032/AF
by Evan Birkhead.....132

Cipher F880-1 Microstreamer
by David W. Bynon.....136

Mac/VAX

by Evan Birkhead
White Pine's Reggie.....140

Back End

by John C. Dvorak
A Tale Of Two Idea Men.....176

Letters.....16

ARISTALK.....18

Product Watch22

Products146

New Equipment169

Used Equipment.....170

Classified.....171

Product Showcase.....172

Advertisers Index.....174



The ARIS symbol on an article indicates that the program segments are available electronically on our Automated Reader Information Service. Dial (215) 542-9458.

We will consider for publication all submitted manuscripts and photographs, and welcome your articles, photographs and suggestions. We cannot be responsible for loss or damage. This magazine is not sponsored or approved by or connected in any way with Digital Equipment Corporation. "DEC" is a registered trademark of Digital Equipment Corporation. Digital Equipment Corporation is the owner of the trademark "DEC" and is the source of all "DEC" products. All materials presented are believed accurate, but we cannot assume responsibility for their accuracy or application. DEC PROFESSIONAL Magazine ISSN 0744-9216 is published monthly by Professional Press, Inc., 921 Bethlehem Pike, Spring House, PA 19477. Printing and binding by R. R. Donnelley & Sons Company. Subscriptions are complimentary for qualified U.S. and Canadian sites. Single copy price, including postage, \$4. One year subscription rate \$30 in the U.S. and Canada; and \$60 foreign. All orders must be prepaid. Second Class postage paid at North Wales, PA, and additional mailing offices. POSTMASTER: Send all correspondence and address changes to: DEC PROFESSIONAL, P.O. Box 503, Spring House, PA 19477-0503. COPYRIGHT© 1988 by Professional Press, Inc. All rights reserved. No part of this publication may be reproduced in any form without written permission from the publisher.





Perfect matches to DEC user needs. Hip. Hip. And Hooray.

One-size-fits-all is an attribute best reserved for inexpensive socks. In the realm of PC-based emulation and communications software for DEC mainframe users, it's important to match specific user needs with specific product attributes. We have.

SmartTerm[®] 240 features exact four-color emulation of a DEC[®] VT241 terminal. Along with delivering full-screen ReGIS[®] and Tektronix[®] 4010/4014 graphics, SmartTerm 240 offers precise VT220, VT102, VT100, and VT52 text emulation.

For non-graphics applications, SmartTerm[®] 220 duplicates virtually every SmartTerm 240 text, communication, and ease-of-use feature. Three error-free file transfer protocols, including Kermit and Xmodem, are provided. Downloading minimizes on-line time requirements to boost overall system efficiency. And an optional network package allows direct LAN access to shared modems, printers, as well as host mainframes.

As SmartTerm 240 and 220 focus on graphics and text, new SmartMOVE[®] makes PC-to-the-rest-of-the-World communications sharper than ever. Speed connect, auto redial, and background file transfer features make this VT100 emulator a loud and clear choice for advanced communications requirements.

Graphics, text, and communications. If you're looking for a perfect fit, seek the software sized and priced to match your needs. Persoft has it. Period.

Visit your dealer or phone us at 608-273-6000.

© 1987 Persoft, Inc. All rights reserved. Persoft, SmartTerm, and SmartMOVE are registered trademarks of Persoft, Inc. DEC, VT and ReGIS are trademarks of Digital Equipment Corporation. Tektronix is a registered trademark of Tektronix, Inc.

CIRCLE 175 ON READER CARD

persoft[®]

**DEC UNIBUS USER:
 CONVERT YOUR OBSOLETE
 PDP-11[®]
 TO A POWERFUL '87 MODEL**

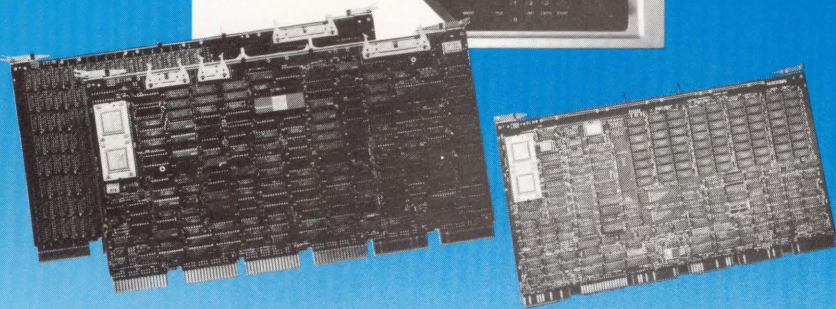

N1100 PLUS

- 4 Mbytes DRAM
- 8 KBytes Cache
- Hardware Floating Point
- Memory Management

N1100

- 2 Mbytes DRAM
- Memory Management
- Serial Line Unit
- Universal Boot ROM

**J-11[®] POWER FOR OPTIMUM
 PERFORMANCE
 FITS ALL EXISTING CPUs —
 NO BACKPLANE CHANGE**

**FOR SPECIAL PRICING ON N1100, CALL OLIVIA AT
 (800) 233-1837 In Calif. (714) 261-8811**

*UNIBUS *PDP *J-11 are registered trademarks of DIGITAL EQUIPMENT CORPORATION

NISSHO
 ELECTRONICS

17310 Red Hill Avenue, Suite 200, Irvine, California 92714 • FAX (714) 261-8819, TLX 181-308

DEC
 PROFESSIONAL

Publisher: Carl B. Marbach
Editorial Director: R. D. Mallery

Editorial

MANAGING EDITOR Lou Pilla
ASSISTANT EDITORS Karen Detwiler,
 Pamela F. Fullerton
PRODUCTION EDITOR Suzanne Garr
SENIOR TECHNICAL EDITOR Al Cini
EAST COAST EDITOR Evan Birkhead
WEST COAST EDITOR Philip A. Naecker
TECHNICAL EDITORS Ron Levine,
 David B. Miller
BACK END EDITOR John C. Dvorak
C EDITOR Rex Jaeschke
DCL EDITOR Kevin G. Barkes
MICROVAX EDITOR David W. Bynon
NETWORKING EDITOR Bill Hancock
RSX EDITOR James A. McGlinchey
SPECIAL EDITOR Victor J. Chorney
UNIX EDITOR Lori A. Snyder
EDITORIAL ASSISTANT Anne Schrauger
CONTRIBUTORS Donnalyn Frey, Scott
 Kitayama, Robert W. Taylor, Ph.D.

Design & Production

DESIGN/PRODUCTION ASSOC. Ruth Ann Leiby
ART/PRODUCTION ASSOC. Timothy M. Kraft
ART ASSISTANT Sue Ann Rainey
PRODUCTION ARTIST Richard G. Kortz
ADVERTISING TRAFFIC COORD. Lori Goodson
TRAFFIC/PRODUCTION ASST. Joann Corvino
TYPESETTING MaryEllen Coccimiglio,
 Diana Yost

Circulation

CIRCULATION MANAGER Betsy Ellis
FULFILLMENT MANAGER Margie F. Pitrone
CIRCULATION DBA Rebecca Schaeffer

PROFESSIONAL PRESS, INC.

PRESIDENT Carl B. Marbach
VICE PRESIDENT R. D. Mallery
VICE PRESIDENT Peg Leiby
EXECUTIVE EDITOR Linda DiBasio
EXECUTIVE DESIGN DIRECTOR
 Leslie A. Caruso
DIRECTOR OF MARKETING Mary Wardlaw
CONTROLLER Andrea Beneke
MIS MANAGER John F. McGlinchey
ASSISTANT TO THE PUBLISHER
 Jan Krusen

For information on how to contact your sales representative, see page 174. Editorial, Advertising Sales, and Executive Offices at 921 Bethlehem Pike, Spring House, PA 19477. (215) 542-7008. TWX 910 333 9522. FAX (215) 628-2845. Easylink 62805174. ARIS (Automated Reader Information Service) (215) 542-9458. Additional Editorial Offices: East Coast Office at 238 Bedford St., Suite 3, Lexington, MA 02173. (617) 861-1994 West Coast Office at 1010 E. Union St., Suite 101, Pasadena, CA 91106. (818) 577-5970.

SOME THINGS JUST NATURALLY GO TOGETHER.

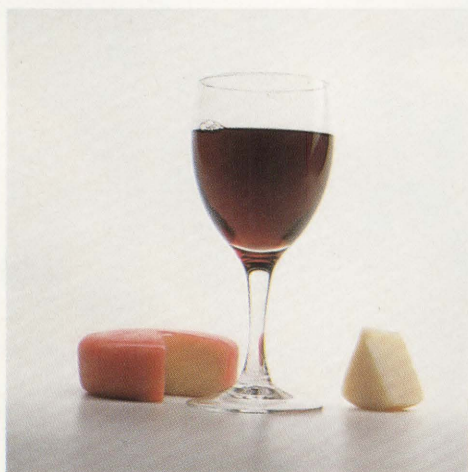
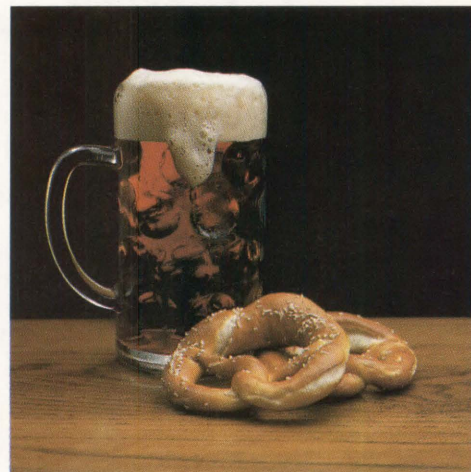
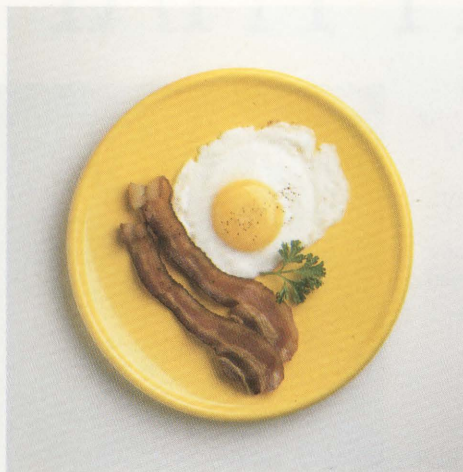

Like needle and thread. Salt and pepper. Emulex and MicroVAX. All are considered well-known pairs.

So it should come as no surprise that Emulex has introduced a family of high-performance controllers for DEC's new MicroVAX 3500/3600 computers.

Two new Emulex products are MSCP disk controllers which support a well-known pair of drives. The QD34 can support four SMD-E drives of any capacity with transfer rates of 3 megabytes per second. The QD24 easily handles four compact ESDI drives with data transfer rates to 15 megabits per second.

Another new product, the QT14 tape controller, features the industry's only switch-selectable capability for a pair of well-known emulations - TMSCP and TSV05.

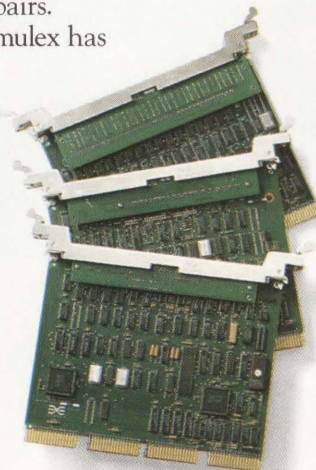

These new products reflect the new MicroVAX form factor and, of course, are totally DEC-compatible. So if you're considering one of the new MicroVAX models, include an Emulex controller to make another well-known pair. After all, some things just naturally go together.

Call (800) EMULEX-3, or
(714) 662-5600 in California
Emulex Corporation
3545 Harbor Blvd.
Costa Mesa, CA 92626



Regional Offices: Anaheim, CA (714) 385-1685 Atlanta, GA (404) 587-3610
Burlington, MA (617) 229-8880 Chicago, IL (312) 490-0050 Dublin, CA (415) 829-1170
Teaneck, NJ (201) 836-3717 Washington, DC (703) 264-0670
International Offices: Bracknell 344-484234 Munich 89-3608020 North Sydney 2-957-1669
Paris 134-65-9191 Tokyo 3-234-8951 Toronto (416) 673-1211

DEC and MicroVAX are registered trademarks of Digital Equipment Corp.

©1988, Emulex Corporation, Inc.

IDMS/SQL[®] AND KNOWLE PUNCH THAT KNOCKS

In the fight for greater performance and productivity, you don't want to enter the ring with anything less than the most powerful database and tools available to you.

For your VAX[™] from Digital Equipment Corporation, they're IDMS/SQL and KnowledgeBUILD From Cullinet. The most powerful VAX database available, combined for the first time with the most powerful, complete toolset. Building on each other, without compromise to efficiency or flexibility.

Consider the facts.

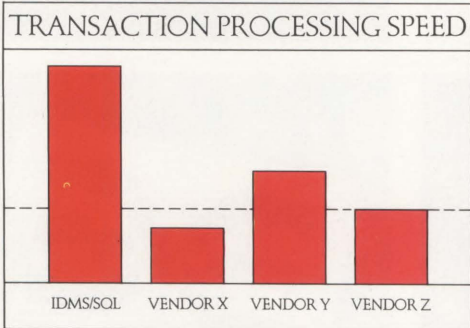

Among the database products available for production-strength applications, IDMS/SQL beats the competition in the most critical areas.

Take transaction processing speed. In an on-line, multiuser environment using the TP1 benchmark, IDMS/SQL is on average three times faster than the competition. And only IDMS/SQL combines modular, high-performance architecture with features like compiled queries, and bulk data access, delivering high transaction throughput.

PERFORMANCE/THROUGHPUT

Compiled Queries	■		■	
Hashing	■		■	
Bulk Data Access	■	■	■	
Save Points	■		■	
Priority-based Deadlock Res.	■			
	IDMS/SQL	ORACLE	INGRES	Rdb

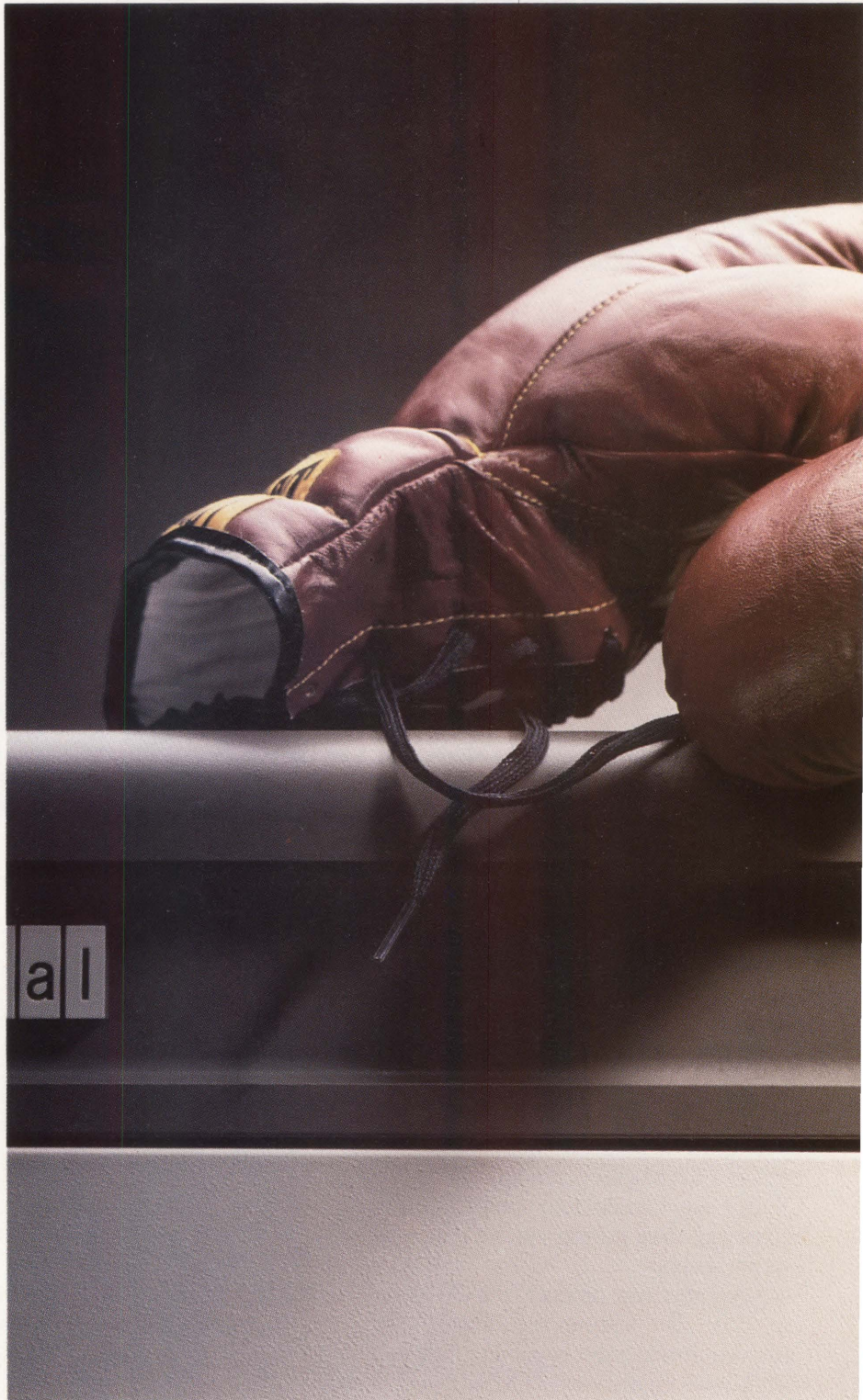

DGEBUILD[®]. THE ONE-TWO OUT THE COMPETITION.

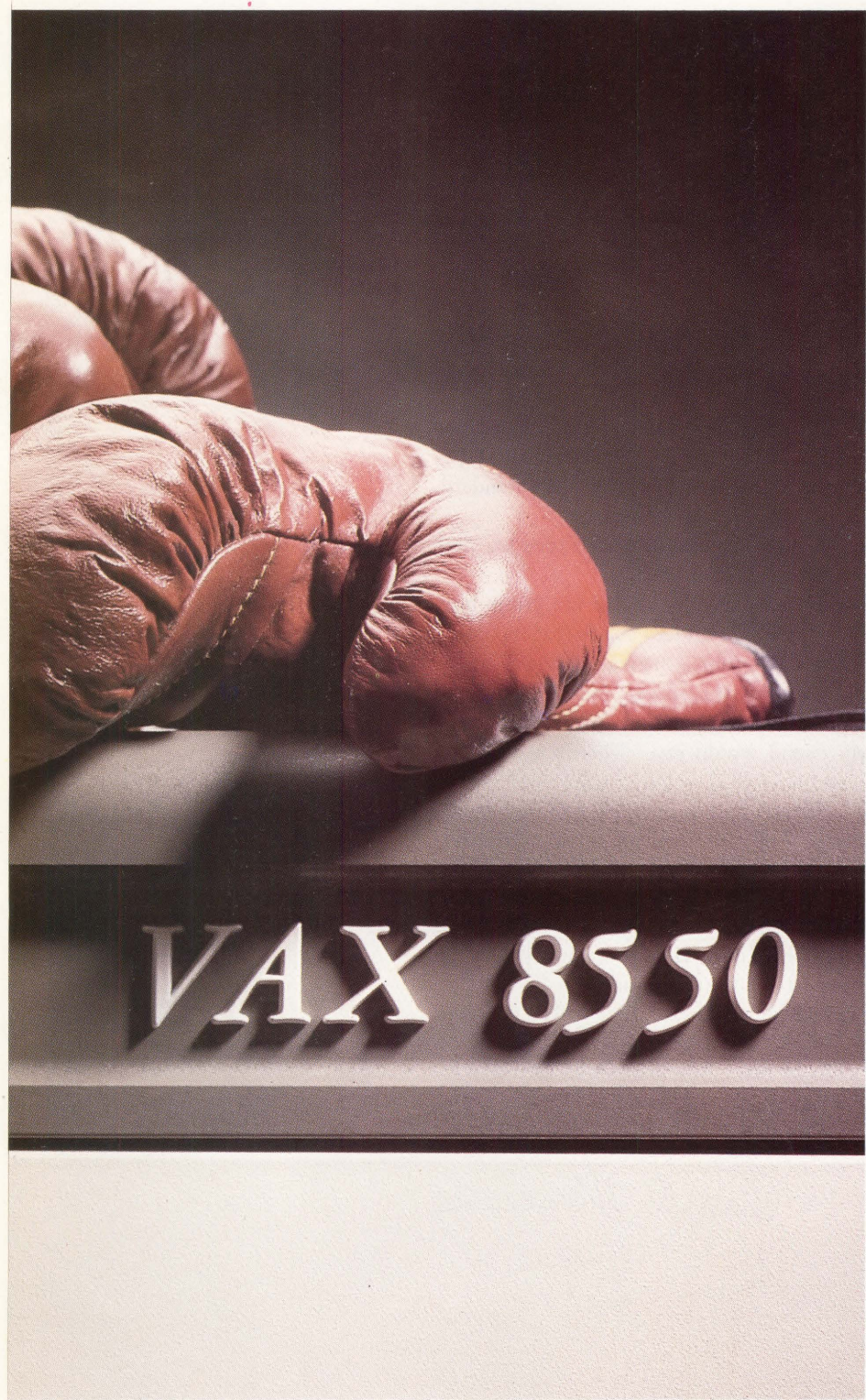

VAX 8550

HIGH AVAILABILITY/HIGH RELIABILITY

Dynamic Database Restructure	■	■	■	■
Dynamic Backup/Archive	■	■	■	■
Dynamic Data Definition	■	■	■	■
DBMS Controlled Dual Journaling	■	■	■	■
Automatic Online Recovery	■	■	■	■
	IDMS/SQL	ORACLE	INGRES	Rdb

There's no obstacle to maintenance, backups, restructuring or archiving. All can be performed without bringing the system down as a result of IDMS/SQL's 24-hour availability, a first in VAX databases. And only IDMS/SQL gives you dual journaling and automatic online recovery to ensure full data integrity, without user intervention.

PRODUCTIVITY TOOLS

Consistent User Interface	■	■	■	■
Multiple Reports/Single Pass	■	■	■	■
Expert Systems Technology	■	■	■	■
Report Painting	■	■	■	■
Non-Procedural/Non-seq. 4GL	■	■	■	■
	Knowledge- BUILD	ORACLE	INGRES	VIA (Rdb Tools)

KnowledgeBUILD accelerates IDMS/SQL's productivity by combining menu-driven form and report painters with non-procedural specifications. Through its powerful program generation capability, KnowledgeBUILD creates efficient, compiled COBOL and FORTRAN applications that work with all your data, whether IDMS/SQL or VAX RMS[™] files. And KnowledgeBUILD's simple, yet flexible reporting facility gives end-users easy access to information.

Give your VAX the extra punch it can only get with Cullinet. Compare the features of IDMS/SQL to those of your current VAX database, or any you might be considering. To find out more call or write Cullinet Software, Inc., Marketing Services, 400 Blue Hill Drive, Westwood, MA 02090-2198.

Cullinet[®]

Call Cullinet today about an IDMS/SQL seminar near you. 1-800-551-4555.

CIRCLE 289 ON READER CARD

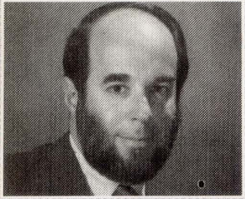

PUBLISHER

Carl B. Marbach

UNIX Wars

In the beginning, AT&T conceived and delivered an operating system. However, unlike DEC, HP, IBM and others who developed proprietary systems, AT&T freely licensed UNIX to anyone who wanted it. Vendors, without the need or ability to develop their own operating systems, used

UNIX as their native system. As a result, many UNIX platforms (computers) became available, allowing buyers to pick and choose (depending on the specific hardware functionality), knowing that the UNIX software would run.

AT&T offered UNIX on its own systems, but because it allowed others to use it, AT&T was viewed as a father figure who could be trusted with the UNIX crown jewels.

At first, UNIX existed on smaller manufacturers' platforms, but later it was adopted by DEC as ULTRIX, HP as HP-UX, APPLE as AUX and IBM as AIX. But just as UNIX was developing into a standard, AT&T threw a monkey wrench into the market. By forming an alliance with SUN, AT&T moved from an enlightened despot to a formidable competitor, and the independents became nervous.

Would they continue to be licensed to use the latest version of UNIX? Would AT&T release one version to the world and keep another version for its own use with SUN? As a result, DEC, HP, IBM and other independents have formed a group that they say will set the UNIX standard, not AT&T.

The independents feel they must do this to protect the position of UNIX. If they let AT&T take UNIX private, they stand to lose their investments in this standard.

AT&T, however, feels like it has borne a child, only to be told by an outside group how to raise it. AT&T gave us UNIX and now someone else will set the standard and decide its future.

If there is a war that results in a split between these two groups, the real loser will be the users of this fine operating system, which has given us some real hardware independence and freedom, along with the opportunity to coin a new word — interoperability — a thought impossible without a standard system like UNIX. My friend would say, "There's a deal here somewhere."

In labor relations, we often resort to a mediator, someone without prejudice for either side and with everyone's best interests at heart. In international relations, neutral third parties have often helped settle disputes. We don't need a totally independent standards setting body for UNIX; that would be unfair to AT&T who conceived of the whole thing. But, if a company chooses to compete with AT&T, it can't use that hold on UNIX to unfair advantage.

Why not appoint a group of independent arbitrators from our industry to allow both sides to submit their ideas and determine the best compromise for the community?

A war benefits neither side. We need to work it out intelligently so that there will be no losers.

Carl B. Marbach



20 GIGS FOR YOUR VAX RIG

Are you being forced to add more HSC50/70 servers when all you need is more storage capacity? The Micro Technology MDI-476, a 2.2 gigabyte, DEC DSA cluster compatible storage device is the highest capacity storage system available.

This system is based on the IBM 3380 concept of using multiple spindles synchronized together to form one physical and logical device. Thus, providing sub 18 millisecond average seek time.

The Micro Technology MDI-476 provides a new more efficient level of connectivity for VAX cluster users. The new device offers almost four times the capacity of DEC's largest disk, the RA82.

Micro Technology, Inc. designs, manufactures, sells, and supports enhancement products for the VAX end user. These products include high capacity and mid-range storage devices, tape back up systems, and network management products. Micro Technology's commitment to our customers is to solve the complex connectivity issues faced in today's rapidly expanding VAX environment.

When your VAX needs to be enhanced, call Micro Technology, The VAX Enhancement Company, (714) 632-7580.

CIRCLE 302 ON READER CARD



Micro Technology, Inc.

1620 Miraloma Avenue • Placentia, CA 92670
(714) 632-7580 • Fax 714-630-2481

Let's Stop All This Finger-Pointing And Get Down To Some Serious Name-Calling.

When something goes wrong with a computer system, everybody wants to know whose fault it is.

We have a better idea.

Solve the problem first. Point fingers later.

As the leading supplier of high performance peripheral subsystems for VAXs, we've seen

our share of the unspeakable. But we've rarely seen the unsolvable.

We're not just talking about emergency service, either. Anyone can come in, smell smoke, and replace the offending device.

We're also talking about things that are much more subtle. Like when your system is red-lined and it's still just too &@%#! slow.



We can look at a whole system and figure out what went south and why. Sometimes better than the people who built it.

You see, what our subsystems and services do best is make Digital Equipment's processors perform better.

And except for those people whose checks are signed "Olsen,"

we have more trained bodies *in the field* to back us up than any other company selling in the DEC marketplace.

So you want to call somebody names?

Call us. **800-333-2220.**

We'll solve your problems faster than you can say "System Industries."



**SYSTEM
INDUSTRIES**

CIRCLE 243 ON READER CARD

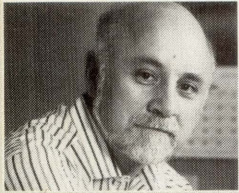

EDITORIAL

Dave Mallery

Survival In The 1990s

There's an old adage that says if you have lots of medium-sized problems and can't get them cleared up, get yourself a really big problem and stand back.

I believe that the recent shotgun marriage of IBM, DEC and Hewlett-Packard is a perfect example. They all had mid-sized problems: specifically, they were engaged in guerrilla warfare in each other's mid-range systems, but the possibility of losing UNIX to AT&T and Sun was so awful that they banded together to defend their turf.

All platitudes and truths about the primacy of VMS aside, UNIX is critical to survival in the 1990s. I can see future systems that will have both UNIX and VMS user interfaces and calling standards (maybe SAA compliance as well). A major computer vendor without a UNIX in the 1990s is in trouble.

DEXPO Cincinatti

The DEXPO Cincinatti show was memorable for a few things: The first non-memory non-licensed BI board was there, and a tape coupler from MegaTape using lifted DEC chips had to be the star of the show.

Just as we note the marriage of convenience between IBM, DEC and Hewlett-Packard, we also note an "affair" among System Industries, Clearpoint, MegaTape and perhaps others, banding together to share technology and other resources to bring a true third-party BI corner to the market.

There's a distance to go between supplying lifted chips and a true "clean room" clone of the BI chip and corner. The engineering required is enough to strain the resources of any company, but perhaps if a number of third-party vendors could rise above their guerrilla war for a while and focus on a larger problem, the market will be well served.

Just as an unencumbered UNIX is crucial to the survival of major vendors in the early 1990s, a viable BI clone (in lieu of licenses from a willing DEC) is critical for the survival of third-party vendors.



VAX 8500 VAX 8800

EMC²

EMC CORP

NATICK MA 01748

EMC's New 8000 Series Memory Upgrades Are A Lot Like Digital's. Except They're More Advanced, Better Serviced And More Reliable.

At last, you have an alternative when it comes to memory upgrades for 8500 up to 8800 VAXes. From EMC, the company that's been everyone's favorite all along.

In addition to saving you about 20-30 percent, even more if you've earned EMC trade-up credits, they'll impress you in ways you've come to expect.

For starters, our modules use the latest 1Mbit chips instead of older 256K RAMs. Which means our boards are inherently more reliable, since they use about 1/4 the number of connections.

And while we're on the subject of reliability, consider our stringent testing procedures. After burn-in, each board spends at least 24 hours running test patterns and diagnostics in one of our own VAX™ 8000 Series computers. Which is more quality control than even Digital provides.

What's more you'll get some pretty comforting guarantees from EMC.

We guarantee delivery to meet your demands. And we guarantee our boards for the life of your system. If you even suspect a problem, just give us a call. You'll have a replacement in your hands overnight. Or, you can select one of our priority

service plans. In either case, you can return the suspect board after the replacement arrives.

And finally, we can just about guarantee, you'll like working with us. You get the commitment of an industry leader. The financial resources of a \$100+ million corporation to back that commitment up. And the comfort of knowing we have the best track record in the business.

So when your VAX 8000 Series,* or any other VAX for that matter, is ready for an upgrade, move up with EMC. For more information contact EMC Corporation, Hopkinton, MA 01748-9103.

For More Information Or To Order, Call

1-800-222-EMC2

(In MA, call 617-435-2541)

In Canada: 416-922-0419; European Headquarters: In London (01668) 5511;

In Germany: (0619648) 1885.

International Number: +441668 551; U.S. TELEX 948615 EMC CORP NTIK.

Digital and VAX are trademarks of Digital Equipment Corporation.

*EMC 8000 memory includes: 16MB, 32MB, and 64MB arrays for VAX 8500, 8530, 8550, 8700, 8800 computers.

EMC²

The System Enhancement
Company

CIRCLE 121 ON READER CARD

LETTERS

IEEE TREATY

I read with interest your editorial, "A Summit, But No Treaty" (April 1988). There is one misstatement that needs correction. The POSIX standard is being developed by the IEEE P1003.1 Standards Committee, not by X/Open. X/Open is a consortium of computer manufacturers.

Heinz Lycklama
/usr/group Technical Committee
Santa Monica, California

THE ULTRIX STRATEGY

I am concerned about the user community's perception of ULTRIX. In the wake of the formation of the Open Software Foundation (OSF) and the recent cover story on Ken Olsen in *Business Week*, Digital's UNIX strategy has been needlessly maligned. Indeed, its entire distributed processing strategy was raked over the coals in *Business Week*.

While criticism of Digital's late entry into the workstation market and its need to begin competing in CPU price/performance is valid, any malign-

Address letters to the editor to *DEC PROFESSIONAL* magazine, P.O. Box 503, Spring House, PA 19477-0503. Letters should include the writer's full name, address and daytime telephone number. Letters may be edited for purposes of clarity or space.

ing of its UNIX strategy is unfounded. What do people expect? After all, the company is here to sell VMS.

Ken Olsen is fond of repeating a little-known fact about his substantial commitment to ULTRIX — Digital is the number one vendor of UNIX systems. It will probably stay that way for some time, particularly if the VAXSTATION can overtake Sun.

Business Week suggests that Olsen fears open systems. But the week the article was published, Digital, along with IBM, Apollo, HP and others, formed the Open Software Foundation, which will standardize on IBM's AIX. Digital is also a founding father of X/Open, which is pushing the POSIX standard.

Olsen knows that Digital will profit more than anyone else from open systems. That's because a multivendor environment means an increased role for distributed processing and Ethernet,

on which the company's betting the ranch. If ULTRIX is not a pure UNIX, OSF will make all UNIXs equal.

Jim Christopher
Buckingham, Pennsylvania ■

CORRECTION

In May Bookshelf the *Digital Technical Journal* was reviewed. The address and price that were given are incorrect. For further information, contact Will Buddenhagen, Digital Press, 12A Esquire Rd., North Billerica, MA 01862-2587; (800) 343-8321. The price is \$16 each.

CIRCLE 565 ON READER CARD

USER GROUPS

If you have an active user group, *DEC PROFESSIONAL* would like to be informed of your meetings, technical sessions and seminars. Please contact the Editorial Offices at 921 Bethlehem Pike, Spring House, PA 19477.

Megabytes to go.

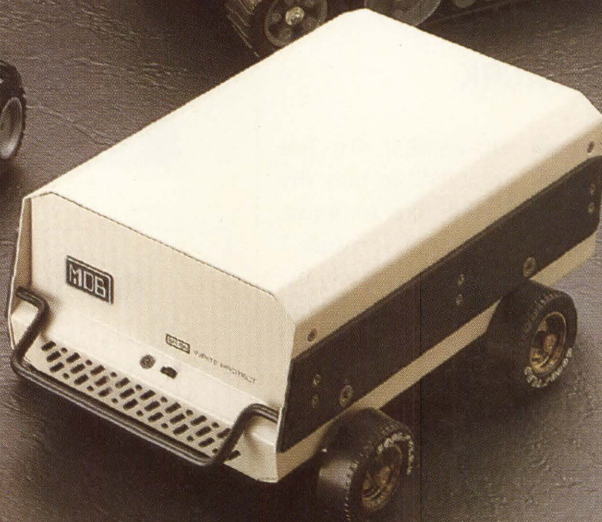
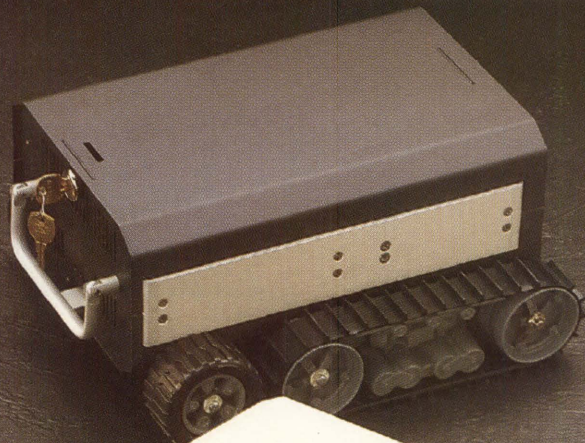

MDB Data Shuttle™ Removable-Drive Subsystems:



(Data Shuttle 2000 illustrated)

For use with all computer systems

DATA SHUTTLE 2000™

The best shock-isolated, low cost design for commercial, lab and industrial applications.

DATA SHUTTLE 3000™

Ruggedized for harsh environments not requiring the added cost of Mil-spec.

DATA SHUTTLE 4000™

The most ruggedized, militarized, Tempest-certifiable removable-drive subsystem today.

The new freedom of shock isolation & data portability.

With up to 760 MB per canister, MDB's Data Shuttle family provides mobility, infinite storage capacity, and Winchester reliability.

Designed to get you in and out of a wide range of environments from shock isolated commercial use, to the harshest requirements of Mil-spec, the removable canisters provide the ultimate in security and archiving as well as ease of software updating. You also gain maximum system uptime during disk replacement. Plus, all three models are equipped with a quick-release power down feature; no cables to disconnect.

As for flexibility, you can configure any 5¼" storage drive in canisters or specify one with a permanently mounted removable media back-up drive.

They come with a one-year warranty including shock related failure and are available with or without controllers or drives.

The DATA SHUTTLE family is for use with all computer systems. ESDI, ST506, RD5X and SCSI interfaces are jumper selectable. See what we're driving at. Call today for complete details.

— We put the *State of the Art* to work —

Corporate Headquarters
1110 W. Taft, Box 5508, Orange, CA 92613-5508
TEL: (800) 556-0222 In CA (800) 637-2028
FAX: (714) 637-4060 TWX: (910) 593-1339

FOR UNITED KINGDOM: MDB Systems, U.K., Ltd.
Intec 2, Wade Road
Basingstoke, Hants. RG24 0NE
TEL: 0256 464767 FAX: 0256 59748
TELEX: 858389 MDBSYS G

FOR WESTERN EUROPE: MDB Systems, IRL., Ltd.
Portumna Co., Galway, Republic of Ireland
TEL: (353) 509 41163/41413 FAX: (353) 509 41447
TELEX: 50918 MDB EI

Data Shuttle 2000, 3000 and 4000 are trademarks of MDB Systems, Inc.

MDB
SYSTEMS INC.

HOOKING A PC TO A NETWORK

QUERY:

Eric S. Dungan (SIG 24/MESS 151): I'm trying to hook up a PS/2 60 into my DECNET network. I'd like to know what Ethernet boards and software I need to accomplish this. I'm mainly interested in transferring information from my VAXCLUSTER to the PC and vice versa. I have a line on Etherlink MC boards from 3Com and would like to know if there are any other boards that will accomplish it. Also, do I have to use DECNET/DOS and will it work with a third-party board like 3Com's?

REPLIES:

Kevin Verble (SIG 24/MESS 154): I know DECNET-DOS supports the 3Com and MICOM Ethernet boards. I don't know how a PS/2 would fit in with either DECNET-DOS or the Ethernet boards. You also can use synchronous DECNET. We did file transfer testing over a DEPCA Ethernet board connection and a 9600 null modem cable connection using DECNET-DOS. The Ethernet came out approximately 10 times faster. Other than the speed, you can't tell the difference.

Ken Miglionico (SIG 24/MESS 155): There are several boards/software available to do this: CommUnity-DOS from TCI (Ethernet board), another from 3Com and DEC's DEPCA board. Others are RAF from Datability Software Systems and Mobius from FEL Computing. We chose the DEC solution of the VMS/DOS/Server with PCSA software. We're only in the infancy of this project, but initial results are promising. Keep in mind that some of these products are file transfers and don't address VT com-

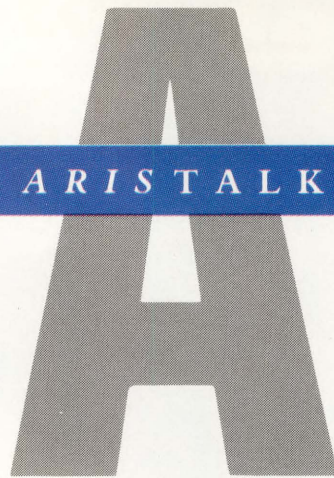

How To Use Aris

If you're a subscriber to *DEC PROFESSIONAL*, you can call up our VAX and log into ARIS, Our Automated Reader Information Service. In ARIS, you can download programs from this publication, communicate with our editors, request a change of address, find additional information about advertisers, order books and back issues, check the guidelines for submitting articles, take a peek at our editorial calendar for the year and communicate with other VAX users.

To log in, you'll need your subscription number from your mailing label. Set your terminal to seven data bits, one stop bit and space parity, or eight data bits, one stop bit and no parity, and dial (215) 542-9458. Baud rates: 300, 1200 or 2400.

Recent Changes

As a *DEC PROFESSIONAL* subscriber, you can download any of the programs marked with an ARIS symbol in *DEC PROFESSIONAL*. You can access programs from *VAX PROFESSIONAL* only by also subscribing to that publication.

When you're in ARIS and don't wish to return to the Main Menu after each operation, you now can use the new BRIEF mode. It turns off the menu display after you get into ARIS. To turn it on, type BRON from the Main Menu; to turn it off, type BROFF.

XMODEM is available.
KERMIT is available.

SIG Identification

The SIG categories referenced in this month's *ARIS*talk are:

24PCs
43Editors (EDT, TPU, etc.)

patability, E-MAIL and some other features. The DEC software lacks none of these and uses existing VAX disks as the storage medium; therefore, your PC can be diskless (except for a floppy for uploads), and you can use your VAX/xxx as a file server for the PC software and the data files.

EDT PROBLEMS/VMS 4.6

QUERY:

Nora Miller (SIG 43/MESS 174): I upgraded my MICROVAX II to VMS 4.6, and EDT isn't working properly. Using KP1 to move one word at a time, the cursor stops at colons, brackets, equal signs, etc., while skipping over the beginning of a word preceded by a tab. Worse, when the cursor's on the last word in a line, pressing MINUS to delete a word deletes the word, the EOL character and the first character on the next line. This isn't how EDT works on my 785, even under VMS 4.6. It's driving my users crazy. Has anyone had this problem? I've asked DSIN about it but haven't heard yet.

REPLIES:

Jonathan M. Prigot (SIG 43/MESS 175): Because you say it occurs only on the MICROVAX and not the 785, I suspect someone may have implemented a systemwide EDTINI.INI file.

Nora Miller (SIG 43/MESS 177): This shows how blind we can be. I've been trying to resolve this EDT problem and discovered that the word entity had been redefined. I was positive that my .INI file was the same as on the other machine where EDT still works. Then, just for fun, I looked at the .INI file. It was different! It must have come with the upgrade. I renamed it out of the way,

While you're waiting for your DEC PrintServer™ 40 Think about Our model 3840

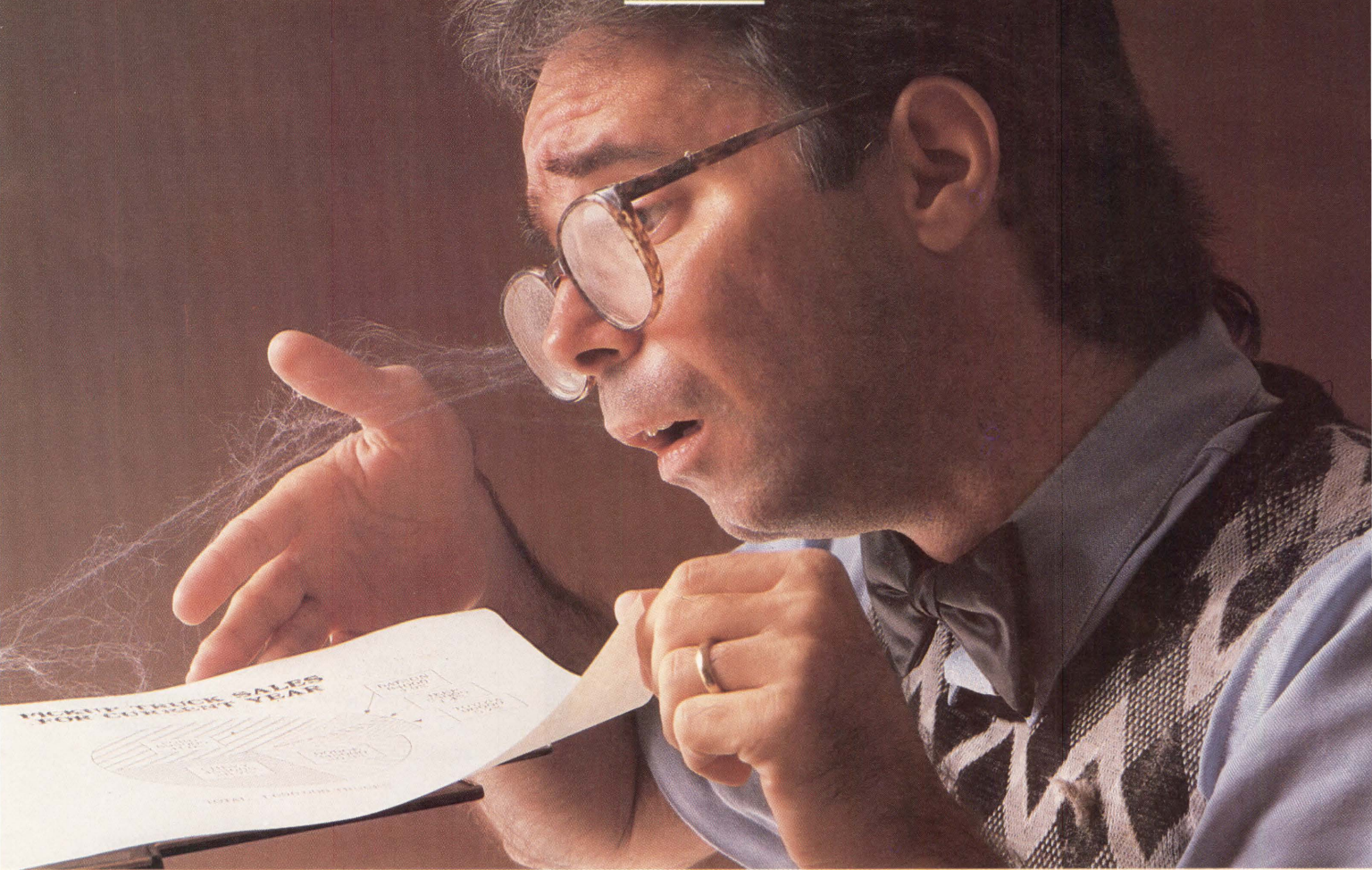

25% Lower Purchase Price; Half the Cost-per-Copy

Sure, your DEC PrintServer 40 is *rated* at 40 pages per minute, and it will run at that rate, provided the form has only fixed text fonts and very simple graphics. Let the job get a little complicated, however, and you'll see a *pronounced* performance degradation. And that's *after* you've paid about \$15,000

Typical
one-hour
output of a
graphics/text
combination
form.



NBS model 3840

more for the printer and *while* you're paying about twice the cost per copy compared with NBS Southern's Model 3840 Laser Printer.

By connecting directly through a high-speed NBS parallel port, no special software is required to run the model 3840. With the addition of NBS Southern's PAGEWARE™ Forms Description Language (FDL), you can merge text with complex documents, logos, signatures and other special graphics without sacrificing speed.

Our 3840 will deliver complex forms, text and ANSI X3.64 graphics, in any combination, at a true 40 pages per minute with 300-dots-per-inch resolution. All day. Every day. Up to 200,000 pages per month —

DEC PrintServer 40

four times the duty cycle of the DEC PrintServer 40.

The 3840 houses a true 57 resident fonts, expandable to over 150 — all in bitmap form, ready to use. In fact, the printer supports the entire Bitstream® font library.

If you're running any DEC system with big print output requirements, you need to investigate the NBS Southern model 3840! Contact us at 100 North Belcher Road, Clearwater, FL 34625. Telephone 813/441-1981; outside Florida 800/327-5602; FAX 813/447-3012.

NBS
Southern, Inc.

CIRCLE 142 ON READER CARD

VISION

Everything You Always Wanted in A Project Management System And Less . . .

Less Hassle.

If you have ever had to use ARTEMIS or PROJECT/2, you will appreciate VISION. As easy to learn and use as a micro system and with the power of your DEC VAX, Prime or IBM mainframe.

SYSTONETICS

1561 E. Orangethorpe Ave. • Fullerton, CA • 92631 • (714) 680-0910 • Telex 692-327

Sales and Support Offices: San Jose, CA • Houston, TX • Atlanta, GA • Vienna, VA • Denver, CO • Bellevue, WA • Eatontown, NJ • and offices in Japan, Denmark, Korea, United Kingdom, Singapore, Italy, Norway, Saudi Arabia, and Australia.

ARTEMIS is a registered trademark of Metier Management Systems, Ltd. PROJECT/2 is a registered trademark of Project Software and Development, Inc. IBM is a registered trademark of International Business Machines Corporation. DEC VAX is a registered trademark of Digital Equipment Corporation. Prime is a registered trademark of Prime Computer, Inc.

CIRCLE 232 ON READER CARD

PowerStation™

A Complete VT220 / VT241 Work Station Upgrade for the IBM PC/XT/AT and PS/2

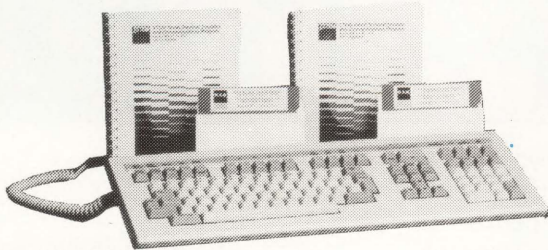

"Now true 800 pixel wide VT241 display and support for VMS Services for MS-DOS."

PowerStation™ 240 \$435
VT240 style keyboard and ZSTEM VT240 Emulation Software. Optional WPS labelled keys (GOLD KEY MODEL) add \$30.

ZSTEM pc™ - VT240 Emulator \$295
Emulation Software only. VT240/241 Emulation Software with all the features of ZSTEM VT220 plus ZSTEM 4014, sixel and ReGIS graphics.

PowerStation™ 220 \$289
VT220 style keyboard and ZSTEM VT220 Emulation Software. Optional WPS labelled keys (GOLD KEY MODEL) add \$30.

ZSTEMpc™-VT220 Emulator \$150
Emulation Software only. All the features of ZSTEM VT100 plus 8-bit mode, downloadable fonts, user defined keys, full national/multi-national modes. Extended macros-/script language. True 132 columns on Hercules, VGAs, Super EGAs, and standard EGAs using the EGAmate option. 128 columns on CGAs. 43 line support on EGAs. Enhanced keyboard support. Ungermann Bass Net/One and VMS Services for MS-DOS support.

EGAmate™ \$39
Daughterboard option for 132 columns and true 800 pixel wide ReGIS display on standard EGA adapters.

PS220/2 \$19
Keyboard adapter cable for PS200 on PS/2 systems.

ZSTEMpc™-4014 Emulator \$99
Use with ZSTEM VT100, VT220, or stand-alone. Interactive zoom and pan. Save/recall images from disk. Keypad, mouse, digitizer, printer, plotter, and TIFF support. 4100 color and line style color mapping. 640 x 400 and 640 x 480 on some adapter/monitors.

ZSTEMpc™-VT100 Emulator \$99
High performance COLOR VT100. True double high/width, smooth scrolling. ISO and attribute mapped color. XMODEM and KERMIT, softkey/MACROS, DOS access.

KEA Systems Ltd.

#412 - 2150 West Broadway, Vancouver, B.C. Canada V6K 4L9
Telephone (604) 732-7411 Telex 04-352848 VCR Fax (604) 732-0715
Order Toll Free (800) 663-8702
30 day money back guarantee AMEX/MC/VISA

CIRCLE 132 ON READER CARD

and sure enough, EDT works like the old editor I know and love.

Thanks for the suggestion, Jon. I plan to ask at DECUS if this file came with the distribution, and if so, why.

PCs ON PCSA

QUERY:

Ken Miglionico (SIG 24/MESS 149): I'm currently installing PCs on ThinWire Ethernet running under VMS/DOS/Server software and PCSA software, not just file transfer. The vendor recommended a Wyse PC/AT compatible. No way! It must be an IBM or a VAXMATE. The documentation is poor, the system is complicated, and it must be managed by a knowledgeable person. However, when up, it's an impressive system. All software and data files reside on the VAX. The PC accesses everything through MS-WINDOWS via the VAX disks.

My system manager left for another position in the middle of the installation. Is there anyone who has been through this and can provide some help? There aren't many sites using this, and getting tips is difficult; even DEC has difficulty. I'm searching for a new system manager and would like to have some expertise available when he comes aboard.

REPLIES:

Bill Mayhew (SIG 24/MESS 150): Version 2 of the PCSA software is supposed to include considerable improvements in the areas of documentation, performance and functionality. That leaves out cost, but PCSA is virtually free if you have DECNET.

Phil Galka (SIG 24/MESS 156): I understand part of what you're doing. We have the IBM PCs connected throughout ThinWire Ethernet. We also have been successful with disk server under DECNET and DECNET-DOS. The big problem with DECNET's implementation of virtual printer is the reference of an IBM PC device, NPRN.

Most PC software won't see this as a valid device, and you must use the PC, print to a file and then type file.txt > nprn.

ARROW/KIERULFF MAKES BUYING CONTROL DATA 8" SABRE™ DISK DRIVES A BREEZE.

Whether you're designing a new system or upgrading an existing one, ordering Control Data 8" Sabre disk drives from Arrow/Kierulff makes your job a lot simpler. We handle everything from pre-sale support to post-sale service. So integrating these powerful products into your system is a breeze.

All five Sabre Series models provide high-performance, high-capacity storage in a small form factor. With capacities ranging from 368 Mbytes to 1.23 gigabytes, data transfer rates of 1.8 to 3 Mbytes per second, and a choice of interface options, you're sure to find the right Control Data drive for your application.

As Control Data's only full-service national distributor, Arrow/Kierulff is positioned to give you the service and support you require. Our Computer Product Specialists will provide technical assistance to help you select the right Sabre drive for your system. And if you're upgrading your system, our Custom Computer Products Group will configure a DEC-compatible subsystem to your exact specifications. What's more, we can arrange for optional installation and extended warranties through Control Data's Engineering Services Group.

So order your Sabre drives from Arrow/Kierulff today. Then sit back, relax, and leave the leg-work to us.

For you—free—product literature and more information on Arrow/Kierulff's support services, complete and return the attached coupon.

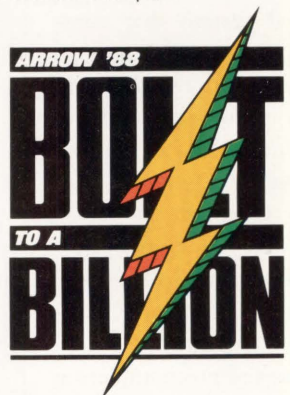
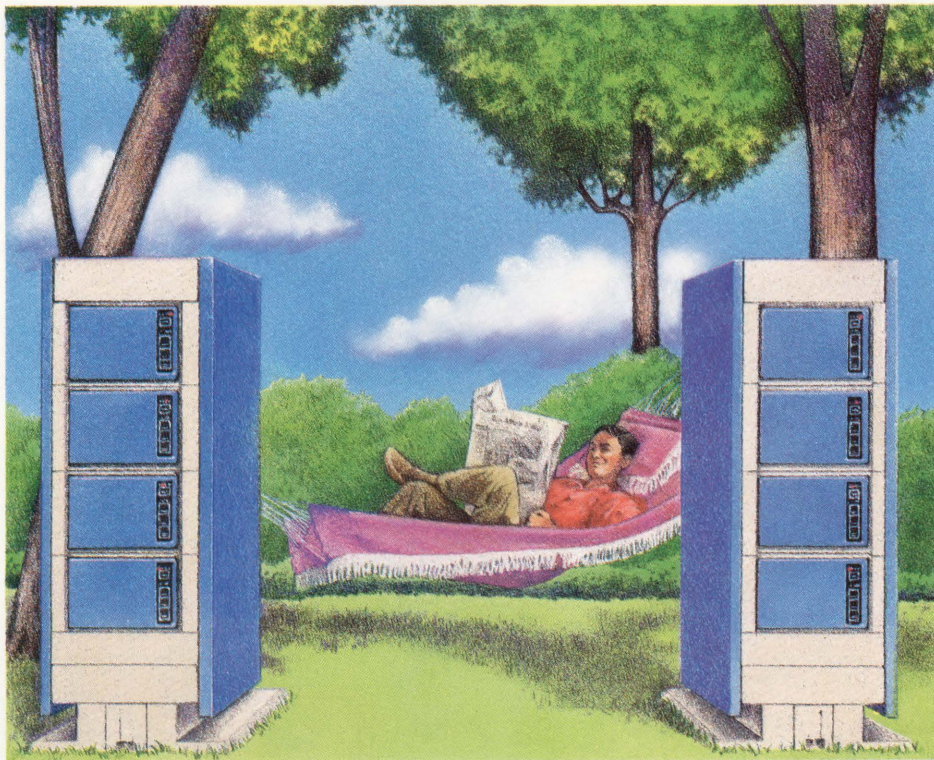

Powered by strong relationships with quality companies like Control Data, Arrow is bolting to \$1 billion of sales in 1988.

There is a difference in distribution. Arrow.™

CIRCLE 293 ON READER CARD

ARROW ELECTRONICS, INC.



ALABAMA

Huntsville (205) 837-6955

ARIZONA

Phoenix (602) 437-0750

CALIFORNIA

Los Angeles (818) 701-7500
Orange County (714) 838-5422
San Diego (619) 565-4800
San Francisco (408) 745-6600

COLORADO

Denver (303) 790-4444

CONNECTICUT

Wallingford (203) 265-7741

FLORIDA

Ft. Lauderdale (305) 429-8200
Orlando (407) 323-0252

GEORGIA

Atlanta (404) 449-8252

ILLINOIS

Chicago (312) 250-0500

INDIANA

Indianapolis (317) 243-9353

IOWA

Cedar Rapids (319) 395-7230

KANSAS

Kansas City (913) 541-9542

MARYLAND

Baltimore (301) 995-6002

MASSACHUSETTS

Boston (617) 935-5134

MICHIGAN

Detroit (313) 971-8220
Grand Rapids (616) 243-0912

MINNESOTA

Minneapolis (612) 830-1800

MISSOURI

St. Louis (314) 567-6888

NEW HAMPSHIRE

Manchester (603) 668-6968

NEW JERSEY

Marlton (609) 596-8000
Parsippany (201) 538-0900

NEW MEXICO

Albuquerque (505) 243-4566

NEW YORK

Metro New York (516) 231-1000
Rochester (716) 427-0300

NORTH CAROLINA

Raleigh (919) 876-3132
Winston-Salem (919) 725-8711

OHIO

Cleveland (216) 248-3990
Columbus (614) 436-0928
Dayton (513) 435-5563

OKLAHOMA

Tulsa (918) 252-7537

OREGON

Portland (503) 645-6456

PENNSYLVANIA

Philadelphia (215) 928-1800
Pittsburgh (412) 856-7000

TEXAS

Austin (512) 835-4180
Dallas (214) 380-6464
Houston (713) 530-4700

UTAH

Salt Lake City (801) 973-6913

WASHINGTON

Seattle (206) 575-4420

WISCONSIN

Milwaukee (414) 792-0150

PUERTO RICO

Hato Rey (809) 764-4384

CANADA

Montreal (514) 735-5511
Ottawa (613) 226-6903
Quebec (418) 687-4231
Toronto (416) 672-7769
Vancouver (604) 291-2986

International Export Group

TLX: 4758034

ARROW ELECTRONICS, INC.

ARROW/KIERULFF ELECTRONICS GROUP

25 Hub Drive, Melville, NY 11747

Attn: Chris Johnson, Dept. A1-7

Please send me—free—my Control Data literature packet and Arrow/Kierulff's Value-Added Services Guide. (Offer expires August 31, 1988.)

Please have a salesperson contact me.

Name _____

Title _____

Company _____

Address _____

City _____ State _____ Zip _____

Phone _____

The Search For Spock

AI Database Query And Reporting Language Accesses VAX/ORACLE

Version 1.0 of Spock, a VAX/VMS information retrieval system that combines a natural-language front end with the ability to access information from distributed DBMSs is being shipped by Dynamics Research Corporation (DRC). Spock is an acronym for System Protocol for Online Communication of Knowledge, although system analysts and programmers at DRC constantly refer to the software as *he*.

Spock translates structured English-language queries into Oracle, routes the request to the appropriate database, joins data received from disparate databases (if necessary), then displays the information on the workstation screen in a format suitable for printing or filing. To the user, it doesn't matter which databases Spock decides to access; it effectively looks like one large database.

Spock's reading comprehension is semantically oriented, and its recognition process consists of 3,000 separate modular rules. The modules are organized in layers, each making use of knowledge gained in the adjacent layer.

Common natural-language user queries might look like:

>SHOW ME WHAT YOU KNOW

The software's response would be to show a list of tables it can access.

>TELL ME ABOUT EMPLOYEES IN L.A.

would release a list of last names and job titles, or if desired, an employee code number.

>SHOW THEIR SALARIES

would generate the same list with an added salary column. The salaries might be pulled from a different data-

base than the field office data.

Spock is programmed extensively to recognize user-input spelling and syntax errors and to store the last 20 queries in a window to rerun results quickly. It also can comprehend and respond to reflexive queries — those using pronouns that refer to previous queries — by "learning" from information it retains.

The three primary software components of Spock are:

1. A workstation definer that resides on an 80286-class (PC/AT or PS/2) workstation. This manages the natural-language interface with the user.
2. A data accessor that resides on the host, handles communications with the host DBMS and extracts information from databases. It

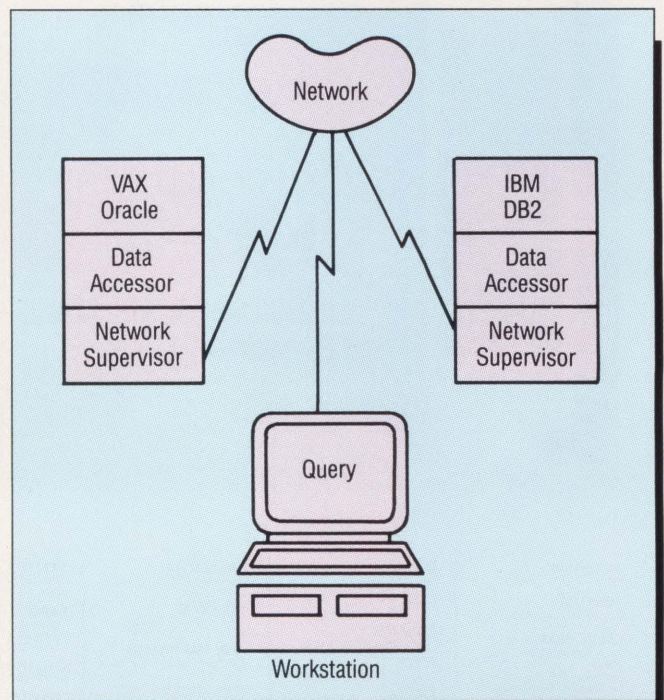

Through software located on the workstation and host, queries are routed transparently to distributed databases.

INGRES DBMS TURNS YOUR WORKSTATION INTO A POWERSTATION.

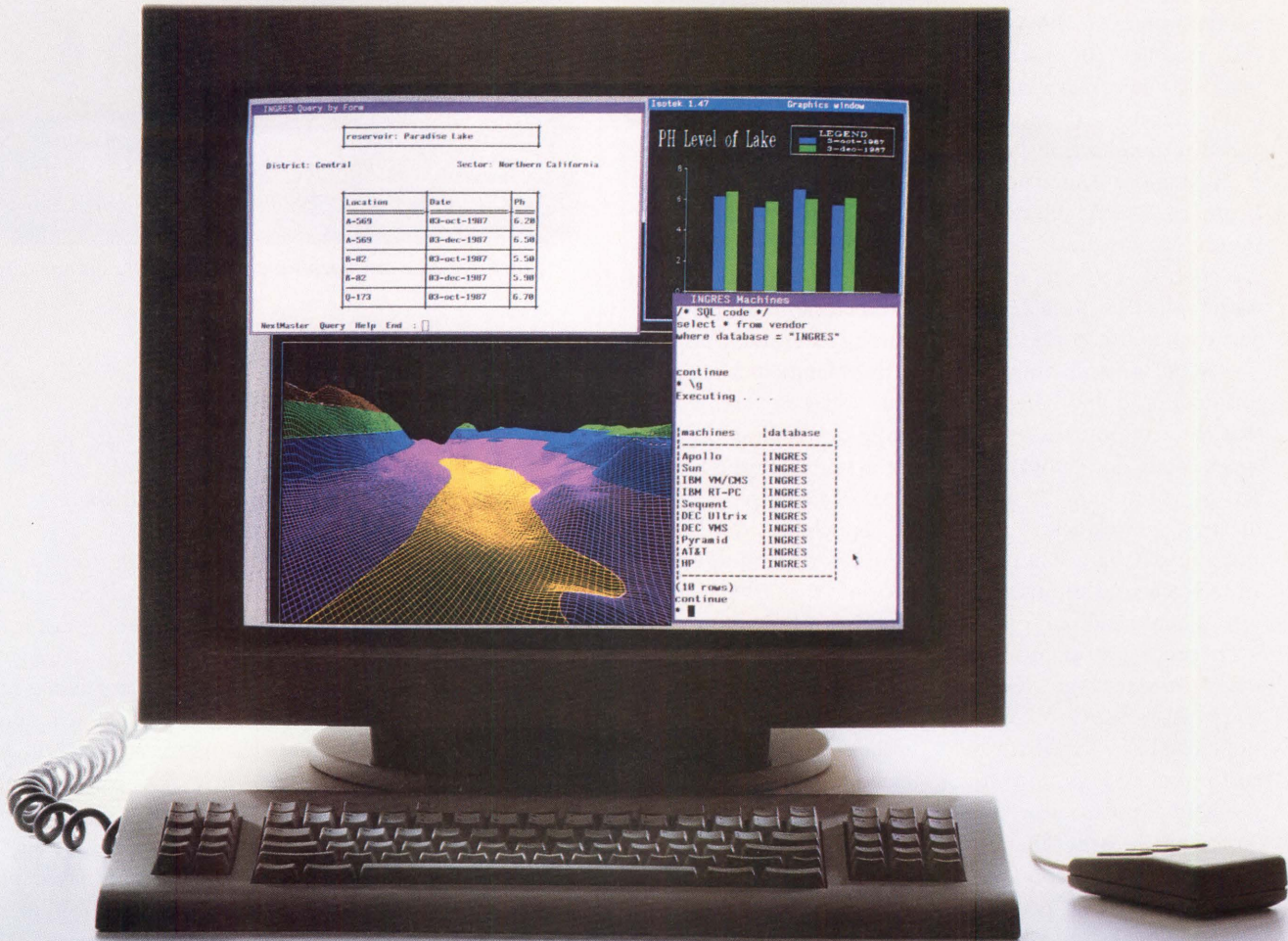

Power. Most people take it for granted. But with the power of INGRES DBMS you can maximize workstation productivity. And that's something no one takes for granted.

Here's what INGRES means to you: Our distributed database capabilities give you the power to put the right information in the hands of the right users, across a network of different operating systems, databases and hardware.

POWER OF THE DISTRIBUTED DATABASE.

In a network of workstations and servers, it all comes down to access. With INGRES in place, workstation users can transparently access any information in a network, without knowing where it resides. And with INGRES/STAR, the distributed data-

base, users can access and integrate data across a wide spectrum of hardware and operating systems. Sun, Apollo, DEC VAXstations and Hewlett Packard applications can access data from each other or from servers running VAX/VMS or UNIX.

POWER TOOLS.

To make the perfect relational DBMS, it takes more than just transparency and distributed capabilities. It takes the very best in end-user and application tools to increase productivity, and to provide for complete portability. And that's where the power of INGRES really comes through. Our innovative 4GL leads the industry in functionality and performance, and we're continuing to set the pace with new tools designed especially for the workstation environment.

PEAK PERFORMANCE.

INGRES contains a powerful database engine that maintains a high level of efficiency at all times, while preserving data consistency and integrity. With its unique optimization and high speed transaction capabilities, network traffic is minimized and superior performance is maximized.

Call us today and find out why INGRES is the one relational DBMS that can power up your entire network.

Turn on the power of INGRES—call **1-800-4-INGRES** for more information. And ask about our free INGRES seminars.

INGRES

RELATIONAL TECHNOLOGY

AWRK806DP

CIRCLE 155 ON READER CARD

INGRES Distributed DBMS for VAX/VMS, UNIX, MS-DOS, IBM VM/CMS, MVS, Relational Technology, 1080 Marina Village Parkway, Alameda, CA 94501

© Relational Technology. Registered trademarks: IBM VM/CMS, MVS, and RT PC (International Business Machines Corporation), VAXstations, VAX/VMS (Digital Equipment Corporation), MS-DOS (Microsoft Corporation), UNIX (AT&T).

essentially translates sub-queries into host DBMS calls and searches for IDs. As many as 10 workstations can communicate with the data accessor simultaneously.

3. A Remote Data Access Protocol (RDAP) network supervisor, also residing on the host, that directs query traffic and sends the accessed data back to the workstation.

RDAP is Spock's internal protocol, a global language that the components use to speak with one another. It acts as a translator between the user and Spock, Spock and the database language, and Oracle and the user.

When installing Spock, it's necessary for the user to "teach" the software vocabulary that's specific to the site's databases in order to customize the system for specific application requirements. According to DRC, you should anticipate that building this personal data dictionary will be an ongoing, evolutionary process. The same front-end screen that's used to issue a query also is used to teach Spock or to ask it to explain its environment. Security can be established by a system manager at the database, table or field level.

The system can expand in two ways: by adding more complete Spock systems on a network or by adding server hosts to the network. The system doesn't pass data through a central hub, as in a star-shaped system. Rather, optimal data paths are determined by cross-system joins between data accessors responsible for talking to dif-

ferent databases.

Although Oracle is the distributed DBMS currently supported by Spock, DRC intends to add Ingres and DB2 to the list and to add Sun and Macintosh workstations as front ends.

DRC designed the program, its first foray into the commercial market, after becoming extensively involved with AI languages interfaces and software architecture, while developing engineering systems for the Department of Defense.

Spock is priced incrementally depending on the size of the CPU hosting Oracle. For example, a workstation definer, data accessor, and RDAP network supervisor cost up to \$6,000 with a MICROVAX II host, less for sites with more than five workstations. The total price then ranges from \$10,000 for a VAX 11/750 to \$35,000 for the VAX 8800, 8974 and 8978. Installation, customization, training and documentation are available as extras, as is an optional PC/AT demo disk that DRC will configure with the data structures of potential customers.

The workstation half of the program is shipped on 1.2-MB floppy disks and the VAX half on tape.

For further information, contact Dynamics Research Corp., 60 Frontage Rd., Andover, MA 01810; (617) 475-9090.

Circle 563 on reader card

Oracle Corp., Davis Dr., Belmont, CA 94002; (415) 598-8000.

Circle 564 on reader card

—Evan Birkhead

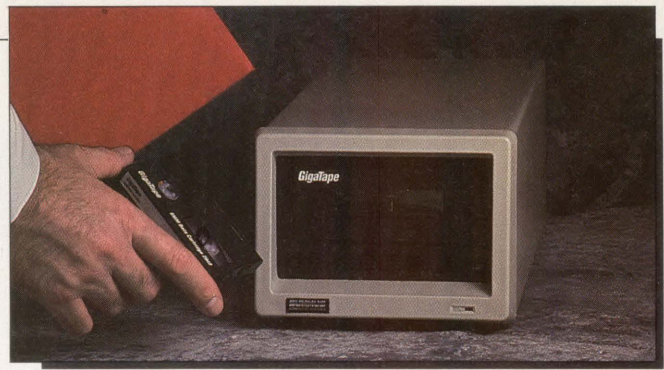

The GigaTape can back up 2.33 GB of data on one cartridge.

GigaTape Answers Data Storage Problems

SUMMUS Computer Systems Delivers Improvements In 5 1/4 Inch Format

Recent studies of fixed or primary mass storage for mini- and supermini-computer systems indicate that the average disk capacity exceeds 600 MB per system. With a projected growth rate of 40 percent per year, the average system mass storage capacity has left present day cartridge and reel-to-reel tape subsystems far behind. In many large systems, complete backups aren't being accomplished and can cause system failures.

Helical scan digital tape technology offers many advantages over stationary head recording. It has experienced an orderly growth pattern parallel to the optical disk in both hardware and media. With the new innovations in helical scan digital tape technology, SUMMUS Computer Systems of Houston, Texas, has targeted the 8mm cartridge market with the GigaTape drive. It's capable of backing up 2.33 GB of data on one cartridge and is designed within the industry standard 5 1/4-inch form factor.

With the GigaTape, an

error correction code (ECC) is employed to ensure data reliability. The ECC can correct a burst as long as 264 bytes in error and as many as 80 additional at random errors in each data block. The ECC is capable of multiple bursts in random error corrections. It's effective against the kinds of error patterns characteristic of cartridge tape subsystems.

Read, write and servo heads are mounted on a drum, which rotates constantly at 1800 rpm, resulting in an effective head-to-tape speed. Actual tape movement is less than 0.5 inches per second. The GigaTape operates as a 819-track, 150-inch-per-second tape subsystem, is software transparent and works with all DEC utilities.

A standard one-year warranty is included. The list price for the GigaTape Q-bus subsystem is \$5,495.

Learn more by contacting, SUMMUS Computer Systems, P.O. Box 820549, Houston, TX 77282-0549; (713) 589-9772.

Circle 580 on reader card

—Suzanne Garr



OPUS2
ASCII
COMPATIBLE

OPUS220
VT-200/100
COMPATIBLE

OPUS4
ASCII
W/WINDOWS

OPUS PCT4
PC-TERM
COMPATIBLE

NEW
OPUS 3n1
ASCII/ANSI
PC-TERM

**FREE
24-HOUR
REPLACEMENT
SERVICE**

A FAMILY OFFER YOU CAN'T REFUSE.

Every Esprit
OPUS terminal comes
with this remarkable guarantee.

Some offers are just too good to pass up. Especially when they guarantee that a terminal will never go down. At least, not at your expense.

Every Esprit Opus terminal comes with the industry's first and only 24-hour replacement service—ESPRIT EXPRESS—free for a full year. So you'll never be burdened with the cost and headaches of the old type of warranty.

It's just one of the benefits of the best buyer protection plan offered by a terminal manufacturer today.

Heading the Esprit Opus family is our newest and most advanced terminal, OPUS 3n1. The epitome of connectivity, it can communicate to almost any host with its resident ASCII ANSI and PC-Term emulations. And connect to two hosts simultaneously thanks to Esprit's dual port capability and all-in-one keyboard.

Add PC-like "Express Windows", Virtual Terminal and ANSI.SYS modes, and an ultra sleek, ergonomic design that

earned our entire OPUS family an Industrial Design Excellence Award, and it's easy to see why OPUS 3n1 will soon be on the most wanted list for multi-user systems running under PICK®, UNIX/XENIX®, VMS/ULTRIX®, VPIX, PC-MOS/MULTI-LINK®, MUC-DOS® and Novell.

For the complete lowdown on the high-performance OPUS 3n1 and the rest of our OPUS terminal family, call Esprit toll free: (800) 645-4508. In NY: (516) 293-5600. We'll make you an offer you can't refuse. And if you're a VAR or OEM, Esprit will show you how our Profit Assurance Program is something you won't want to live without.



Esprit Systems, Inc.,
100 Marcus Dr.,
Melville, NY 11747

CIRCLE 256 ON READER CARD

Network Systems Offers Networking Integration

HYPERCHANNEL-50 Connects Systems From More Than 30 Manufacturers

Time was when each computer installation carried hardware from only one vendor. As computers became specialized, a site might purchase a Cray for complex computations, a VAX for database processing and a Sun workstation for technical development. How could all these computers share information?

One answer is the HYPERCHANNEL-50 network from Network Systems of Minneapolis, Minnesota. For instance, although DEC has a network, it doesn't allow effective communication with Data General, Hewlett-Packard, Apollo or Sun. In engineering facilities, DEC isn't found alone, but various other minicomputers and CAD systems are used. HYPERCHANNEL-50 offers this diverse system integration and is backed up by NETEX software products.

Usually, when you connect a DEC with an IBM, system performance plummets. Using HYPERCHANNEL, the communication can accommodate up to 20 Mbps per DEC communication with the IBM mainframe. Files can be transferred and processed rapidly.

According to Craig Frane, product line manager for HYPERCHANNEL, it has three primary attributes:

1. High performance — The HYPERCHANNEL-50 net-

work consists of adapters that connect computers to multidrop coaxial cable data trunks. Each trunk operates at a fixed transmission rate of 50 Mbps. Each adapter can attach up to four independent network trunks, with rates up to 200 Mbps, and one computer.

"Bulk data oriented," explains Frane, "it transfers large files easily. It permits CPU-to-CPU traffic."

2. Machine connectivity —

You can connect hardware from more than 30 computer manufacturers, using more than 40 operating systems, including DEC, IBM, Honeywell, Unisys, Burroughs, etc.

3. Link adapters — Link adapters connect HYPERCHANNEL-50 networks across high-speed telephone lines, satellite links or microwave facilities. A HYPERCHANNEL network also can be set up locally.

"We're the only company in the industry that offers all three attributes," stresses Frane. "The competition may offer only one or two, but Network Systems gives one-stop shopping."

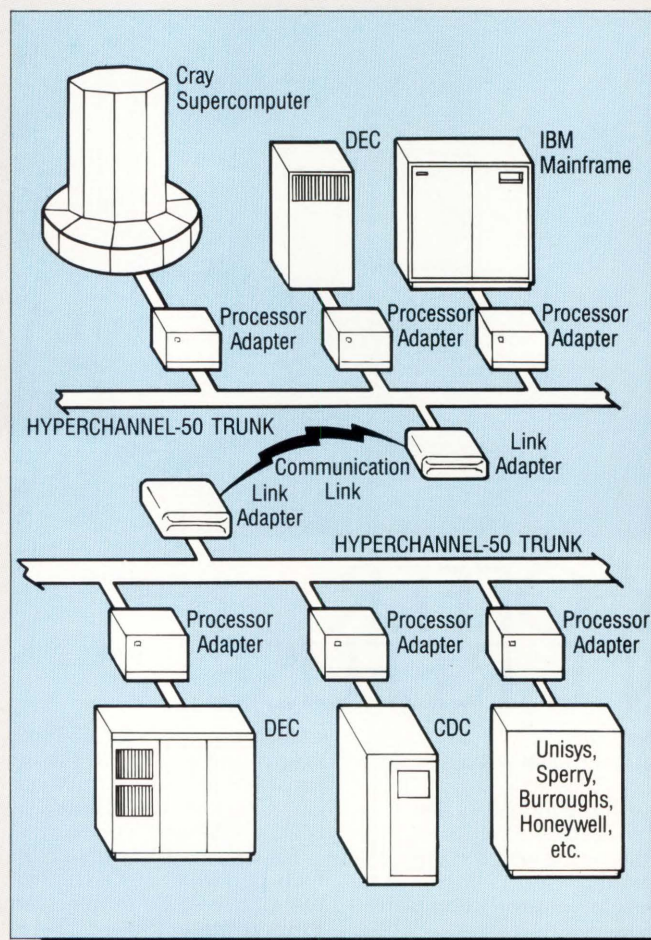

Example of a HYPERCHANNEL-50 network configuration.

A typical configuration costs about \$40,000. This could be using HYPERCHANNEL-50 to connect a mainframe onto a network; one Cray, IBM and four VAXs; or the network onto a satellite.

Looking for enhancements to maintain its market position, Network Systems announced its HYPERCHANNEL-DX in May for shipment beginning in October.

In addition to offering higher performance, it will accommodate standards, including TCP/IP, OSI and Ethernet, through its open architecture. Future plans include adding DECNET and Token Ring.

For example, suppose a customer with four VAXs attached to a HYPERCHANNEL-50 wants even more performance but doesn't want to buy another HYPERCHANNEL. He wants a solution that gives each VAX unrestricted access to the trunk.

The answer is a HYPERCHANNEL-DX, configured with four-port DMA interface HYPERCHANNEL trunk interface and buffer memory up to 16 MB, to eliminate port contention and back-down. Depending on the options selected, prices for the HYPERCHANNEL-DX units range from \$30,000 to \$100,000.

To find out more, contact Network Systems Corp., 7600 Boone Ave. North, Minneapolis, MN 55428; (612) 424-4888.

Circle 561 on reader card

—Karen Detwiler

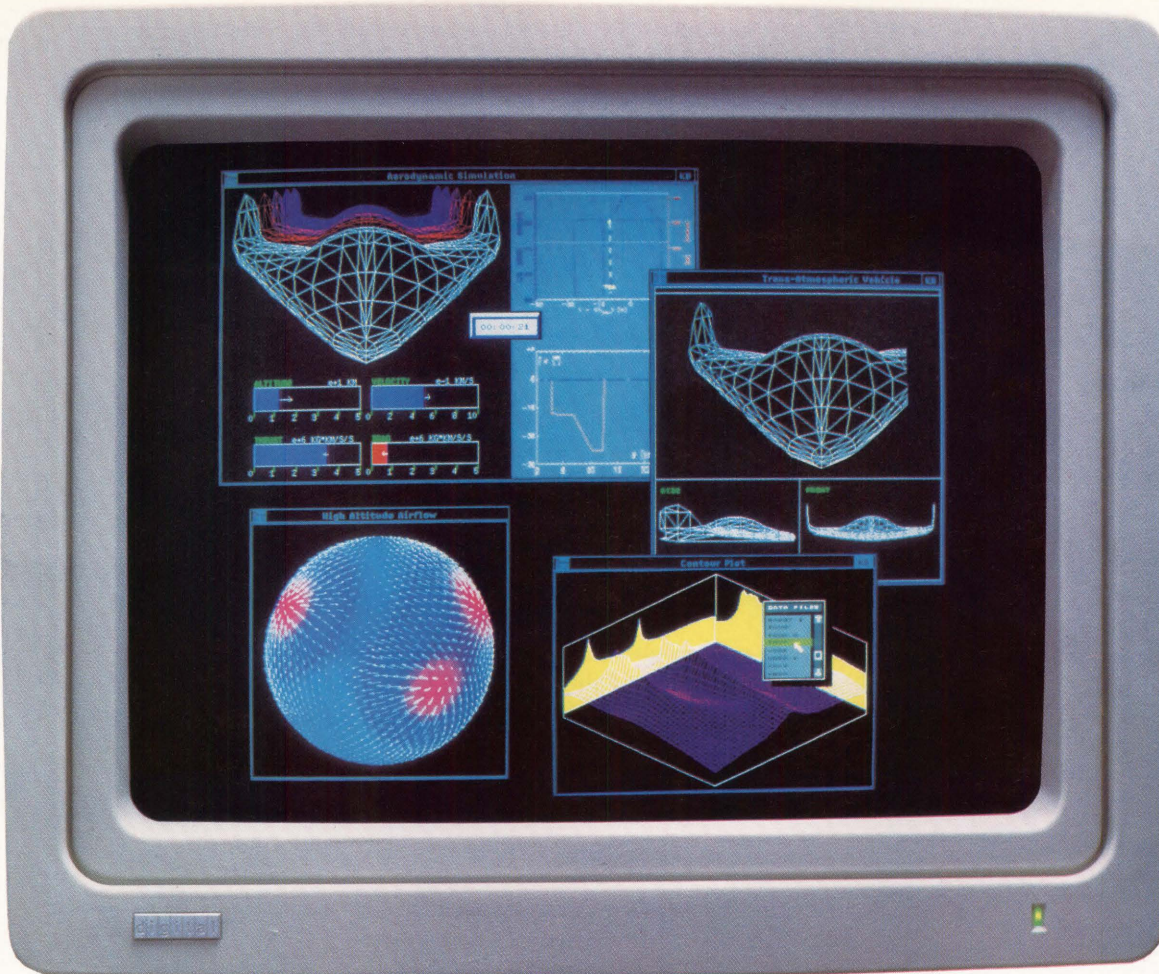

Multiple graphics windows and multiple views are shown in this aerodynamic simulation application. One view is dedicated to rapid updates of data, shown as a strip chart. This view is selectively updated as data changes; the model's view is updated only when the application requests the update.

Software simulations may be disabled on a per-view basis, providing rapid view update.

Pop-up menus and custom cursors are created using GFX-4000's raster operations.

GFX-4000™ from Precision Visuals

Graphics Software Tools for Technical Workstations

The Product GFX-4000 is a high-performance graphics software tools package for application developers. With functionality drawn extensively from the proposed PHIGS* standard, GFX-4000 is enhanced to improve control over functions like windowing and viewing. Our software is optimized for VAXstations to get the most from your hardware.

The Performance GFX-4000 is built for speed. Pictures can be modified quickly using the quick update viewing feature. Graphic information can be sent directly to the screen using temporary data structures, rather than accessing central structure storage. Structures are "posted-to-views," saving time by updating views of the same graphics structures independently. Raster operations are also available to store and manipulate images.

The Integration GFX-4000 will fit your current and future programming environments. It's tightly integrated with the VWS (also known as UIS) window manager, giving the application full control over window management. A forthcoming release will provide

easy application transition to DEC Windows. GFX-4000 supports the CGM standard so you can exchange pictures with the outside world, and you can display your images on most hardcopy devices.

GFX-4000 supports VAXstations running VMS (including models 2000, II, II/RC, II/GPX, 3200, and 3500). Written in 'C', GFX-4000 allows programmers to use either 'C' or FORTRAN subroutine interfaces.

The Features Hierarchical Structures and Structure Editing ■ Multiple Graphics Windows Within a Single Process ■ Multiple Views Per Window ■ Nameset Filtering for Selective Display/Suppression of Graphics Elements ■ Presentation-quality software fonts, in addition to support for hardware text ■ PHIGS standard graphics primitives plus added 2D/3D planar and 3D shell primitives ■ Extensive user support is available through Precision Visuals' telephone HelpLine service and local technical support engineers.

The Applications Software developers use GFX-4000 in a variety of graphics applications, such as

data analysis, data display, process modeling or control, molecular modeling, manufacturing simulation, ME, EE and AEC CAD, and earth sciences.

The Offer To qualify for a free demonstration copy of GFX-4000 or to get complete technical information, phone Chris Logan at 303/530-9000. If your software project requires graphics on a VAXstation, give us a call!



Precision Visuals®

Precision Visuals, Inc.
6260 Lookout Road
Boulder, Colorado 80301 USA
Phone: 303/530-9000 Telex: (RCA) 296428
Fax: 303/530-9329

PVI Precision Visuals International GmbH
West Germany
Phone: 49-69/6 66 65 97 Telex: 176 997 150
Fax: 49-69/6 66 67 38

Precision Visuals International Ltd.
United Kingdom
Phone: (0895) 35131 Telex: 51826715
Fax: (0895)72299

*Programmer's Hierarchical Interactive Graphics System
DEC VAX, VAXstation, and GFX-4000 are registered trademarks of Digital Equipment Corporation and Precision Visuals respectively

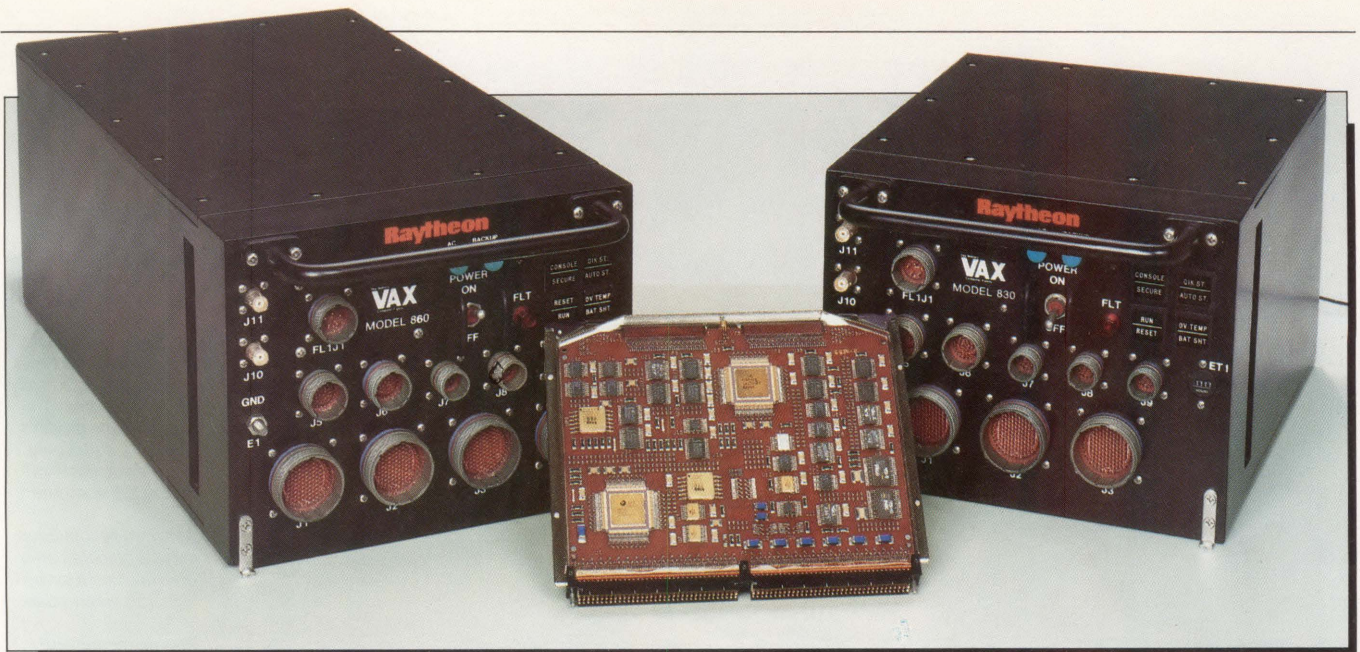

Raytheon models 860, 830 and 810 are military adaptations of the VAX 6200 computer and feature symmetric multiprocessing operating system, VMS V5.0.

Models 860, 830 And 810 Join Raytheon's Family Of Mil-Spec Computers

*Raytheon's Militarized VAX Computers
Provide Solutions For The DoD's
Aerospace And Defense Needs*

Raytheon Company of Lexington, Massachusetts, has unveiled its family of compact computers for military use, built according to military specifications (Mil-Spec) to withstand the extreme conditions of the battlefield; i.e., cold temperatures and radiation. Raytheon models 860, 830 and 810 have adapted the advanced designs of the 6200 series of high-performance, mid-range VAX computers.

The militarized VAX computers are targeted for a broad range of embedded real-time applications in aerospace and defense sys-

tems. Each of the Mil-Spec computers is a militarized copy of the VAX 6200 and is software-identical to existing and future commercial VAX computers. The computers are available in three environmental options: standard temperature (0 to 55 degrees C), extreme temperature (-54 to +71 degrees C) and radiation hardened.

The superminicomputer, model 860, is 0.88 cubic feet, 75 pounds and dissipates an average of 200 watts. The computer can be configured with 1 to 3 CPUs, providing a throughput of 2.5 to 7.1 mips, and is available with 16 to 48 MB of internal memory. A diag-

nostic processor connects to the board level diagnostic subsystem via an independent test maintenance bus and displays status on the module and front panel. The computer accommodates up to six I/O modules, covering a range of peripheral and DoD standard interfaces.

The minicomputer, model 830, features high-performance, 32-bit wide CPU with onboard 256-KB cache, 16 MB of RAM, and capacity for up to three I/O modules internally, plus optional I/O expansion. Model 830 is 0.59 cubic feet, weighs between 44 and 60 pounds and ranges in power from 139 and 242 watts.

The single board computer, model 810, boasts a high performance of 32-bit wide CPU, 512 KB of static RAM and 256 KB of ROM onboard. Memory expansion is available via RAM modules on a dedicated memory bus.

The 810 model is compatible with DEC software tools and compilers including Ada. There's real-time system support by VAXELN operating system. The 810 is a conductor-cooled, surface-mount technology module.

The computers use CPUs that are based on the CVAX chip set. These CPUs work together under the operating system approach known as symmetric multiprocessing. They combine compact size and low power requirements while meeting the rigorous specifications of the military user.

The Mil-Spec computers, models 860, 830 and 810, range from \$185,000 to \$500,000 based on throughput, memory, I/O and environment options.

For more details, contact Raytheon Co., Equipment Division, 528 Boston Post Rd., Sudbury, MA 01776; (617) 443-9521.

Circle 578 on reader card

—Suzanne Garr

It's just a matter of time. And money. You want to save the former. And make the latter. Terminals on your shop floor will help you do both—by extending your computer power to where the action is. 🟡 Obviously they can't be ordinary terminals. Shop-floor terminals have to be "hardened"—built to withstand the hostile environment. But at the same time they have to provide top performance, reliability, and value. 🟡 That's what you'll find in the Hardhat Series from GraphOn. Anything but ordinary, Hardhats provide the best DEC and Tek alphanumeric and graphics emulations—as well as all the other features of our full line of monochrome terminals—protected to NEMA-12 by our special no-fan, no-maintenance enclosures. And sealed Hardhat keyboards are full-function, full travel—and full feel. 🟡 Face it. You're going to put terminals on your shop floor. So get the ones that fit your needs. Phone GraphOn today and we'll bring you a Hardhat to try on. 🟡 1-800 GRAPHON.



GraphOn

CIRCLE 265 ON READER CARD



Face it.
You're going to put terminals
on your shop floor.



PLANTRAC/VMS Project Scheduler Aids Mega-Planners

Computerline's Decision-Support Environment Based On Database Manager

Software is becoming increasingly advanced in the world of project management systems. Sophisticated applications that look like VAX programs are running on micros. And, more important for the DEC market, powerful versions that tap the extensive resources of the VAX are starting to emerge.

Computerline Inc., a London, England-based mainframe and VAX service bureau, entered the project management market with PLANTRAC, a package for IBM PCs and compatibles in 1980. In 1987, with more than 2,000 PC users, Computerline applied its VAX expertise to move PLANTRAC to the VAX in BASIC.

Construction compa-

nies were early users of the system, picking up the advantages of the Critical Path Method (CPM) theory early on. Wally Pears, Computerline's founder and president, is a recognized CPM expert.

Companies involved in planning huge projects that require managing several subprojects, resources and budgets simultaneously, should benefit the most from PLANTRAC/VMS. In fact, these three aspects of planning comprise the organizational columns at the system's front end. A fourth column is for system variations, such as calendars and printing and plotting parameters. The theory behind the system's planning methods is to thoroughly correlate data

in its relational database to help project developers make informed decisions. For example, it's capable of determining resource leveling (how the allocation of resources affect project deadlines) or load leveling (how the number of workers and amount of work they can take on will affect deadlines).

Information is stored in multiple forms, to adjust for various start-dates and deadlines of subprojects. There are several user-selectable reporting options to accommodate this. The Report Writer has two selection screens, and reports can be sequenced according to priority, duration, etc.

Report files can be generated one at a time or batched. The software provides three formats for visually displaying schedules and other reports: the Precedence Diagramming Method (PDM), the Arrow

Diagramming Method (ADM) and bar charts.

This year, Computerline integrated another facility, EASYPLAN, into PLANTRAC. "With its graphical front-end, EASYPLAN lets someone who isn't familiar with project management or PLANTRAC sit down with a computer and draw a logic diagram on the screen," explains Luis Gonzales, who's responsible for planning and tracking the certification of testing equipment at General Electric's Neutron Devices Department in Largo, Florida. "In the past, a manager would sit down with me and plan a schedule; then I would input the schedule into PLANTRAC. Now with EASYPLAN, the manager can build his own project plan."

A utility called OPEN-TRAC allows PLANTRAC/VMS users to extract data from ASCII files in other software packages, including 20/20, Oracle and Rdb, or transfer files to other databases and applications. Menus guide you through record selection and allow any field or combination of fields to be transferred, in any order.

Prices for PLANTRAC/VMS vary according to the number of users, while some software modules can carry an additional cost. Increments include a three-user license priced at \$5,995, a 10-user version at \$14,995 and a 25-user system at \$25,000.

For further information, contact Computerline Inc., P.O. Box 308, 52 School St., Pembroke, MA 02359; (617) 294-1111.

Circle 562 on reader card
—Evan Birkhead

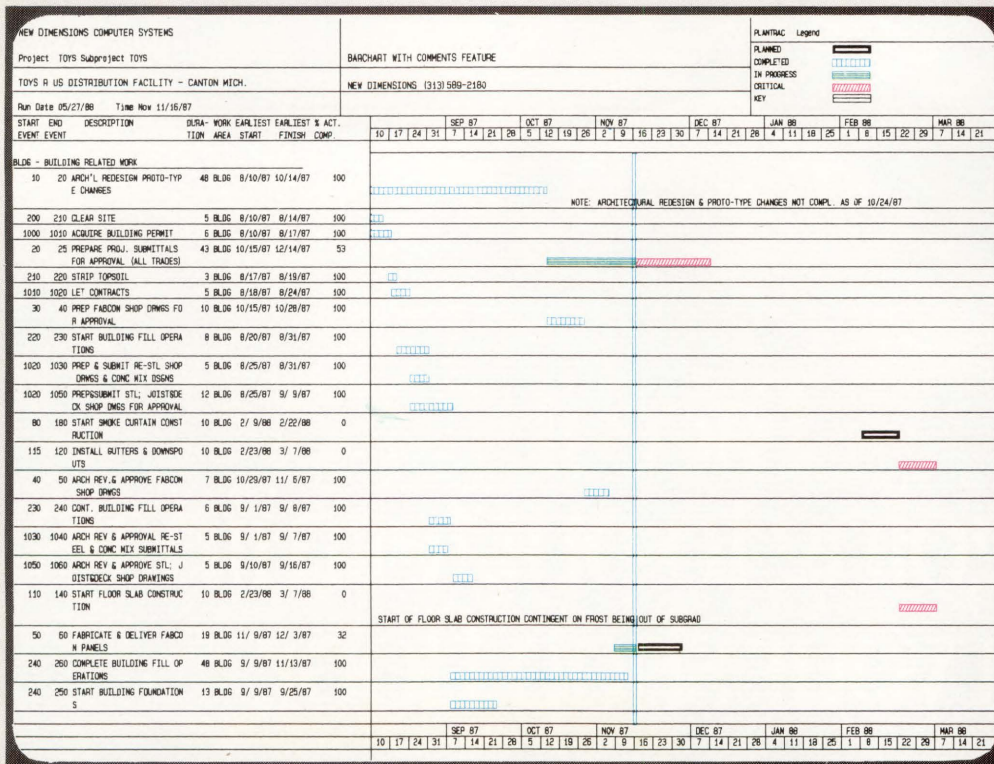

PLANTRAC's color-coded legend specifies proposed and actual project lengths and deadlines.

Introducing the Ditto 320XL...

With More Than 15 Major Improvements over The DEC VT320* ... Perhaps DEC Should Be Emulating Us!



If you're looking to upgrade your DEC environment with a new terminal, don't settle for the limited features and functionality of the DEC VT320. The Ditto 320XL from Networx Data Products Co. has all the features of the VT320 plus over a dozen major improvements, including a 70Hz refresh cycle flicker-free screen, 2 standard and 6 optional pages of memory, an 80-132 column switchable "hot key", and 64K expandable firmware memory for custom OEM applications. And with our optional graphics upgrade (not available on the DEC VT320), you can create incredible graphs, charts, plots and drawings... without disturbing any of the 320XL's alpha-numeric features.

Even with all these extra features, the Ditto 320XL comes with a price tag that's hard to beat. And the Ditto 320XL is backed by a full, one-year nationwide service warranty. Another \$49 buys you a 3-year extended warranty available

directly from Networx.

Why settle for less. See why DEC users are calling the Ditto 320XL video display terminal the best value in today's market. For more information and spec sheets, write or call Networx today at 1-800-531-0019 or (516) 864-5800 within New York State. FAX 516-864-5875.

Networx™

DATA PRODUCTS COMPANY, Inc.

80 Modular Ave. Commack, New York 11725

CIRCLE 235 ON READER CARD

*DEC VT320 is a trademark of the Digital Equipment Corporation

Uniplex Emphasizes Integration And Multiuser Environments

Uniplex Business Software Executes Tasks Quickly And Efficiently

For some, combining word processing, spreadsheet, database and business graphics into a single package is impossible, but for Uniplex Integration Systems Inc. of Dallas, Texas, the task is simple. Uniplex has solved the demands of the working environment by developing Uniplex Business Software, which includes Uniplex II plus, V6.0 and two companion products, Uniplex Advanced Office System and Uniplex Advanced Graphics System.

Uniplex Business Software is available for VAX and MICROVAX computers running under the ULTRIX and Berkeley 4.3 operating systems. This single, fully integrated system means only one set of commands to master. And messages, menus, screens and softkeys are consistent across the entire system.

According to Steve Lee, APR, senior vice president of worldwide marketing, "DEC has driven the growth of departmental computing, and the increased penetration of ULTRIX and other UNIX-like operating systems among DEC installations makes it an attractive market for Uniplex."

Uniplex II Plus, the base product, is a fully integrated, multiuser office system for UNIX-based computers, which combines word processing, spreadsheet and a

relational database into a single package. Uniplex II Plus also includes screen and menu-building capabilities and business graphics.

The ability to communicate information both within an organization and to the outside is crucial to today's office. Uniplex addresses this issue with the Advanced Office System, a companion to Uniplex II Plus. The Advanced Office System provides the necessary components for effective group working: electronic mail, time manager, card index, personal organizer and a report writer.

According to Xev Gittler, system programmer at MIT's Health, Sciences and Technology Department, "The Advanced Office System is the simplest for someone who has no documentation in front of him. This system enables him to hop right on our MICROVAX. We have 500 users in remote locations, making it difficult to teach them, so this package enables them to learn the system easily. For us, it's the most intuitive package."

Presentation is becoming an increasingly important factor in business communication. The Advanced Graphics System allows use with high-resolution terminals to offer a range of charts, graphs and freehand drawing capabilities with Presentation Graphics and Presentation Editor. All products are fully integrated at the source code level with

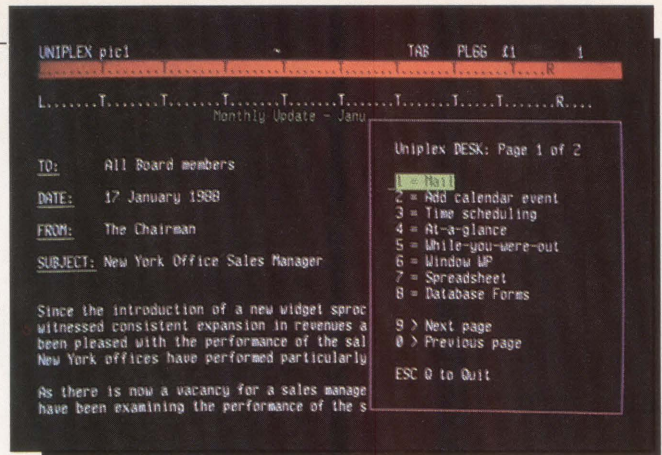

The Advanced Office System is accessible from any screen using a convenient pop-up window.

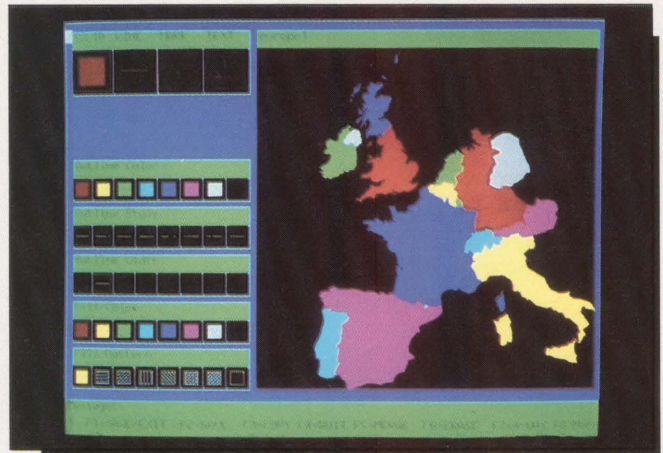

Uniplex Presentation Editor allows users to use freehand drawing and tracing ability to create eye-catching graphics. This map of Europe was traced in minutes, then each country was filled with a different color.

all functional areas of Uniplex software.

Pop-up menus, which can be accessed while in any component of the Uniplex package by pressing a single key, are the user's primary tools for navigating through the system.

An enhancement to V6.0 is the windowing feature that allows users to toggle between processes. If a user is in one window and wants to return to a preceding window, he can use the Escape XS function. If he needs to know what other processes are open, the Escape XP

function will list what processes currently are running. According to David Leoning, U.S. public relations director, "The windowing feature is a significant enhancement to V6.0."

Uniplex Business Software ranges from \$2,495 for Uniplex II Plus on a MICROVAX 2000 to \$61,185 for three components of Uniplex Business Software on a VAX 8800.

For further information, contact Uniplex Integration Systems Inc., Suite 1300, Glen Lakes Tower, Dallas, TX 75231; (214) 373-4971.

Circle 579 on reader card

—Suzanne Garr

ARSAP™

VMS V5
COMPATIBLE

The system accounting product that stacks the DEC™ in your favor.

With ARSAP you can do it all. Everything from capacity planning to performance management to project accounting. ARSAP was designed to work with VMS, so you don't need to change your operating procedures to put this comprehensive system to work for you. And because of its exclusive options, ARSAP is the most efficient and powerful system accounting product available today.

Manage users and control project costs using ARSAP reports.

Selective Image Accounting reduces accounting files by as much as 90%.

Only ARSAP allows you to select and report on the specific applications you choose, instead of the familiar "all or nothing" alternative offered by other systems. This valuable option saves thousands of I/O's to your system disk and reduces the space requirements of accounting files by as much as 90%!

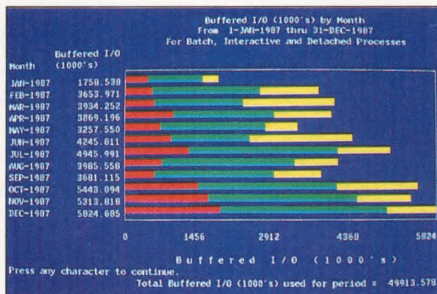
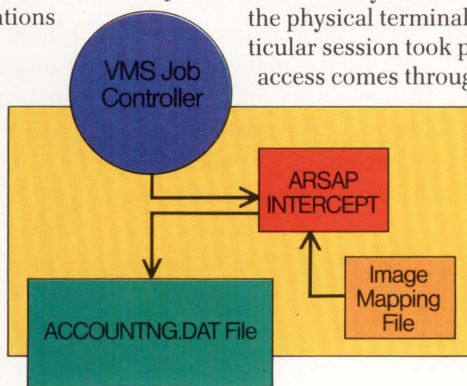

Analyze historical data to plan system resources required for future growth.

Disk Management and Global System Reporting aid long-term capacity planning.

With ARSAP, you can generate easy-to-read bar chart capacity reports for any accounting statistic available from VMS, including CPU time, memory utilization, buffered I/O's, direct I/O's, connect time, and more. And our disk management reports identify amount of space allocated to each user and total amount of free space remaining.

Terminal Reporting tracks usage for control and troubleshooting.

ARSAP's exclusive terminal reporting feature lets you track usage and locate the physical terminal on which a particular session took place, even when access comes through virtual terminals, Intergraph™ workstations or DEC servers (LATs).

Intergraph™ workstations or DEC servers (LATs).

Use "ARSAP Intercept" to automatically select image data for software reporting.

Get the details on ARSAP today.

ARSAP (version 6.0) is the product of 11 years of system accounting design. No other software package is better suited to your DEC system or your system accounting needs. Only ARSAP offers you a complete solution. For more information about how ARSAP can meet your needs call GEJAC today.

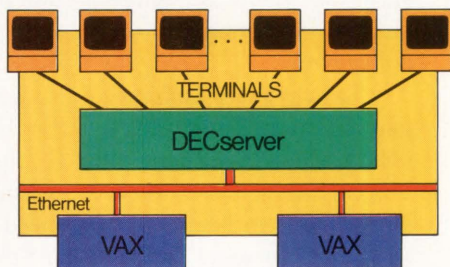

ARSAP gives you the "evidence" to effectively allocate limited hardware among users.

1-800-43ARSAP

(1-800-432-7727) • (301) 725-2500



Mail the coupon below to GEJAC, INC.
8643 Cherry Lane, Laurel, MD. 20707

Name _____ Title _____

Company _____

Address _____

City _____ State _____ Zip _____

Telephone _____

Send information on:

Chargeback Performance Evaluation

Project Accounting Capacity Planning

Resource Management Software Package Reporting

Printer Forms Tracking Other

I have these VAX/VMS systems:

of systems _____ Model #'s _____

ARSAP is a registered trademark of GEJAC, Inc. DEC is a registered trademark of Digital Equipment Corp. Intergraph is a registered trademark of Intergraph Corp.

Western Union Provides Insurance Communication

InsLink Enables Agents And Insurance Companies To Exchange Information

It's an understatement to say that the insurance industry is paper intensive. Consider all the rates, underwriting requirements, types of policies (life, health, property-casualty) available from thousands of companies. How's an agent supposed to remain aware of all this data?

Conversely, when a policy applicant is waiting for his new policy so he can drive his spiffy car out of the showroom, he doesn't want to hear about delays, while the insurance carrier asks the agent for additional information pertaining to the policyowner.

To help speed communications in the insurance industry, Western Union, of Upper Saddle River, New Jersey, plans to begin marketing in September a transparent electronic interface among agents and insurance companies. The interface is called InsLink.

Matthew Lampell, director for industry marketing at Western Union, sums up the system as "an application to transport data and information between the agent's office and the insurance office."

Here's how it works. Suppose a person wants a homeowner's policy for his new house. To apply for one, he goes to the XYZ Agency in his hometown.

The agent takes down the pertinent information

and sends it through InsLink to get rates from a variety of carriers. The agent decides that the applicant gets the best deal from an insurance company 1,000 miles away.

He submits the application through InsLink, which automatically translates the application into the standard format desired by insurance carriers. InsLink can send a message back to the agent, requesting additional information, and the agent sends the answer through InsLink. Then InsLink notifies the underwriter that the application has come in for review and approval. At that point, the policy is processed, and it's sent to the agent.

Information can be sent to the carrier by dial-in, scheduled delivery or a high-speed link between InsLink and the company mainframe and/or office messaging system. The method of delivery from InsLink to the company depends on the traffic level and can change as that changes. There also can be ASCII/EBCDIC translation.

Information can be sent to two different addresses at each company, one for policy type data and the other for text. It facilitates delivery direct to the correct system, which saves effort for the addressed company.

Furthermore, InsLink takes advantage of Western Union's myriad electronic services. For instance, a company with a proprietary system can communicate with

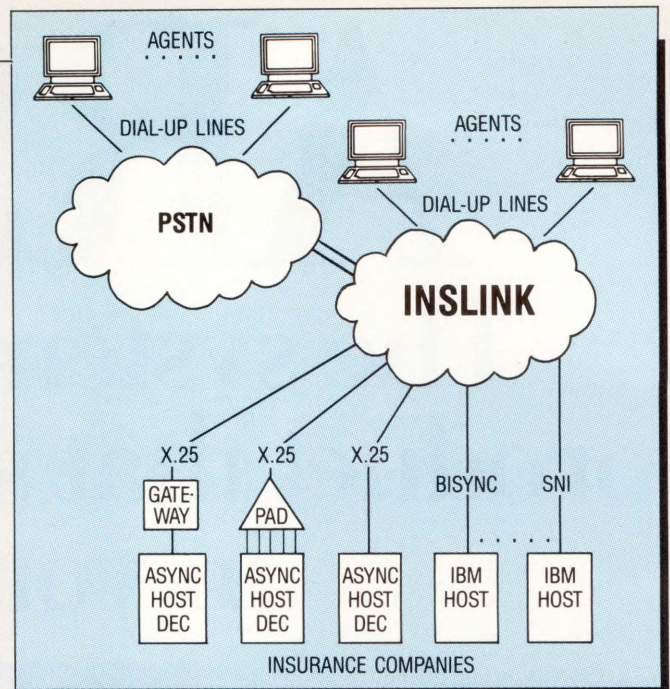

Western Union's InsLink provides communication and transmission of data among agents and insurance companies.

agents outside that system, and InsLink can provide these agents with the ability to reach other insurance companies. InsLink also permits electronic messaging to adjustors, reinsurance companies and others.

In addition, InsLink features a Hotline Service. This allows agents to route traffic to the host computer of a company's proprietary system.

Insurance companies and agents also can use Western Union's Telex services and InfoMaster information retrieval, which offers simplified access to more than 800 online databases covering a broad range of topics. They also can access the FYI News service, a continually updated database of current news and financial reports. Underwriters using Western Union's online database services can retrieve the latest credit, disclosure, and product hazard information to evaluate customer risk potential.

In addition, InsLink users can access private bulletin boards to post messages to internal or external audiences. They also can access the RediList feature to send notices and rate changes to multiple agents, grouped by geographic location.

Billing for the use of InsLink can be configured according to the needs of the insurance company. For instance, the company can pay all the charges for the top agents, pay only for the transmissions that result in sales for the next level of agents, and have independent agents pay for their own transmissions.

Each transmission is billed according to length. Lampell estimates an average range of \$0.35 to \$2.00 for most calls.

For more information, get in touch with Western Union Corp., One Lake St., Upper Saddle River, NJ 07458; (201) 825-5000.

Circle 462 on reader card

—Karen Detwiler

FOR OVER 5 YEARS,
WE'VE BEEN MAKING
LIFE EASIER FOR
COMPUTER SYSTEM
MANAGERS.

IT HAD TO END
SOMETIME.

MEGATAPE ANNOUNCING THE BEST CHOICE IN THE BUSINESS

Sorry fellas. We know how much you depend on us for disk backup systems that are idiot-simple and Old Faithful-reliable. For years, we've been making your life easy with "push the button and go home" backup of even the biggest disks.

But things have gotten more complicated. There are now major tradeoffs available between speed, capacity, and cost.

If your system is big, busy, and expensive, minimizing downtime is probably a major consideration. So you want the fastest backup possible.

On the other hand, smaller systems and networks may be able to get by nicely with a much less expensive but slower backup solution.

The point is that no single backup answer is right for everybody.

So now, MegaTape offers you a choice. The exceptional cost/capacity of 8mm. Or the "industrial-strength" performance of our proven cartridge technology—now dramatically upgraded.

You can still pick up the phone and order a MegaTape system for just about any minicomputer or workstation network.

But now you'll have to decide *which* MegaTape system to order.



ANCES THE HARDEST CKUP BUSINESS.

NEW

MT-1500

CHOOSE
BLINDING
SPEED
AND HIGH
CAPACITY.

BIBUS
Direct
Attachment

When speed counts, nothing tops the new MT-1500. At maximum transfer rate, this rugged powerhouse backs up 1.2 gigabytes on a single cartridge in under 30 minutes. And it offers features you simply can't get anywhere else:

- Up to three plug-in interfaces: any combination of Pertec and SCSI. A front panel switch selects the CPU.
- Complete software compatibility. No need for special device drivers or backup utilities.
- Comprehensive local and remote diagnostics. A technician can easily troubleshoot the entire system from the front panel—or from across the continent, using a terminal and modem.

The MT-1500 comes in rackmount and tabletop configurations, and is designed for easy OEM customization. It's even read compatible with the previous generation of MegaTape systems.

NEW

GT-88

CHOOSE
ROCK-BOTTOM
COST AND
EVEN HIGHER
CAPACITY.

Even though the new 8mm data cartridges promise eye-popping capacity and unbeatable cost per megabyte, we saw a few problems.

So our engineers made the problems go away. Presenting the remarkable new GT-88: the only 2 gigabyte, *Pertec-compatible* tape cartridge system you can buy. With an absolutely unique set of big-computer features:

- Works with existing software. No changes to device drivers or backup utilities are necessary.
- A full 1.25 MB of Cache, for burst-mode transfer rates up to 500K bytes per second.
- Optional switching between two different CPUs at the push of a button. The GT-88—complete with AC power supply—is conveniently packaged as a tabletop unit or in 8" form factor to fit standard enclosures. And it's format-compatible with other 8mm backup systems.

© 1988 MegaTape Corp.

THE EASIEST CHOICE OF ALL: MEGATAPE SUPPORT.

Although you might have to spend some time choosing between backup technologies, choosing a backup *company* shouldn't take you any time at all.

There simply isn't anybody else in the business that has the commitment, expertise, and track record that MegaTape does.

	GT-88	MT-1500
Capacity (formatted)	2.0 GB	1.2 GB
Transfer rate (burst)	500 KB/sec	1,340 MB/sec
(sustained)	246 KB/sec	764 KB/sec
Interfaces	Pertec	Pertec, SCSI
I/O ports	1 or 2	up to 3
Dimensions (in.)	4.5H x 8.6W x 14.0D	8.75H x 19.0W x 24.0D

So while we may have complicated your choice a little bit, in the end the right decision is obvious.

MEGATAPE CORPORATION
1041 Hamilton Road
Duarte, CA 91010-0317
(818) 357-9921 • Telex: 510 600 7131
Telefax: (818) 357-2369

 MegaTape

THE GREAT LEAP
FORWARD IN BACKUP.

Data Sharing

in a

VMS/UNIX ENVIRONMENT

A LOOK AT various types of data sharing techniques.

BY ROBERT W. TAYLOR, Ph.D.

IF EVERY PERSON, program and organization were an island of information, users and corporations wouldn't want to share information. But, programmers work in teams, organizations are split into functional areas, large organizations are split into smaller units and laws require that individuals, organizations and governments keep records and share them.

Computing technology has changed radically during the last 30 years, and the definition of data sharing has changed, too. Data sharing used to mean all the applications that ran on a given computer could share common data. In today's environment, multiple workstations, minicomputers, large computers, from a variety of vendors

and using a variety of operating systems, need to share data.

The reason is the same as it was three decades ago: When everyone is working from the same set of facts, decisions are made faster and more accurately. How many times has your program failed, because someone changed the control block structure, the screen name or the file format, and you didn't find out in time?

Organizations do the same thing. Engineering changed a part number, but Purchasing didn't find out about it in time and ordered the wrong thing.

Mistakes cost time and money. Data sharing is the ability to have everyone working from the same set of facts, even in the face of distributed data ac-

cess and processing. Data sharing helps solve problems. Let's analyze the kinds of data sharing that are possible today and look at illustrations of their benefits.

What's Required

Given a mixture of VAX machines, some running VMS and some running on ULTRIX, or a mixture of VAX/VMS with Sun workstations running the Sun OS variant of UNIX, what are some requirements and desirable features of this shared environment?

The first requirement is consistent, concurrent shared access to a common database. Response should be fast enough to accomplish useful work; otherwise the service won't be used.

A second requirement is to be able

Figure 1.

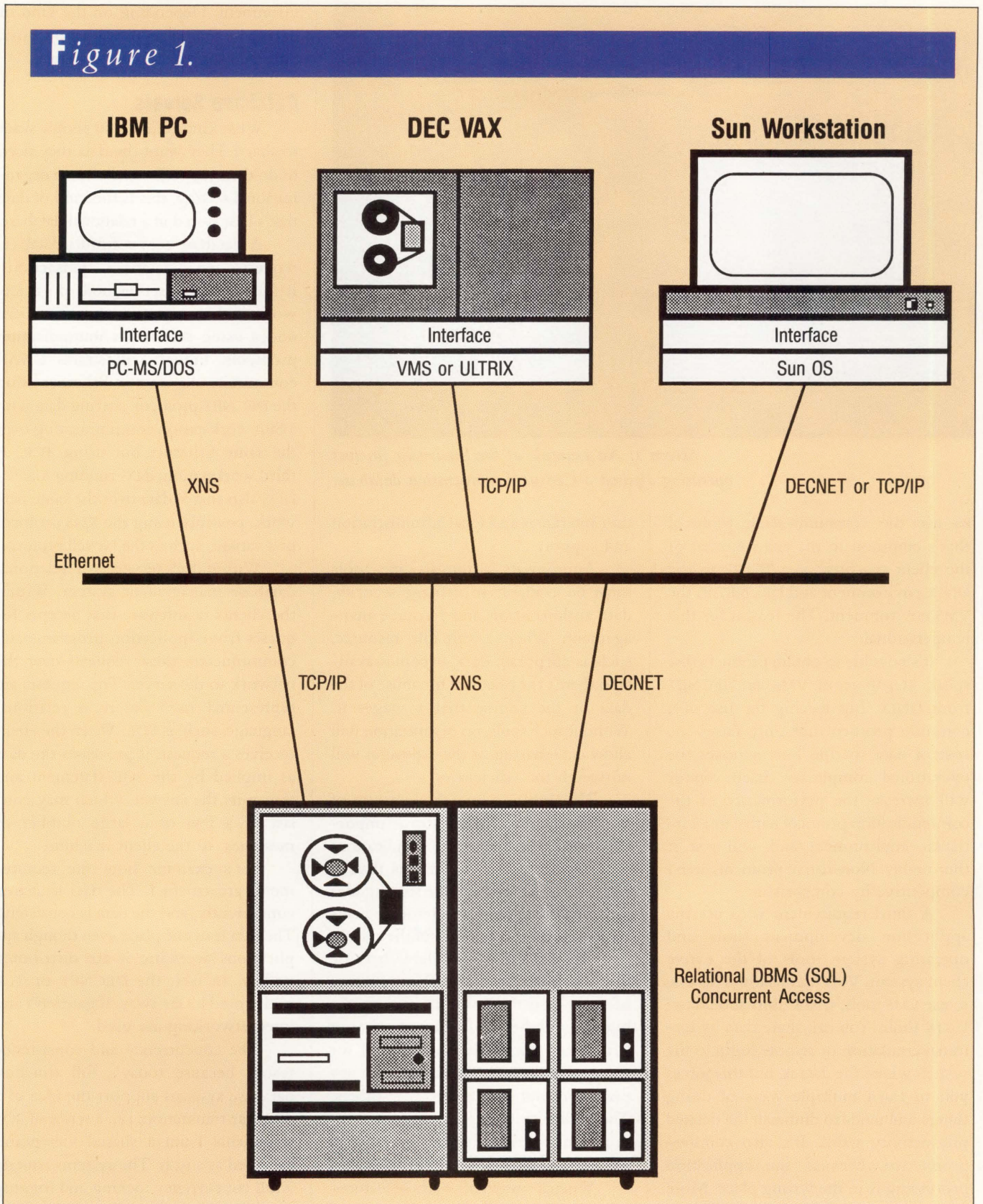

Data server architecture.

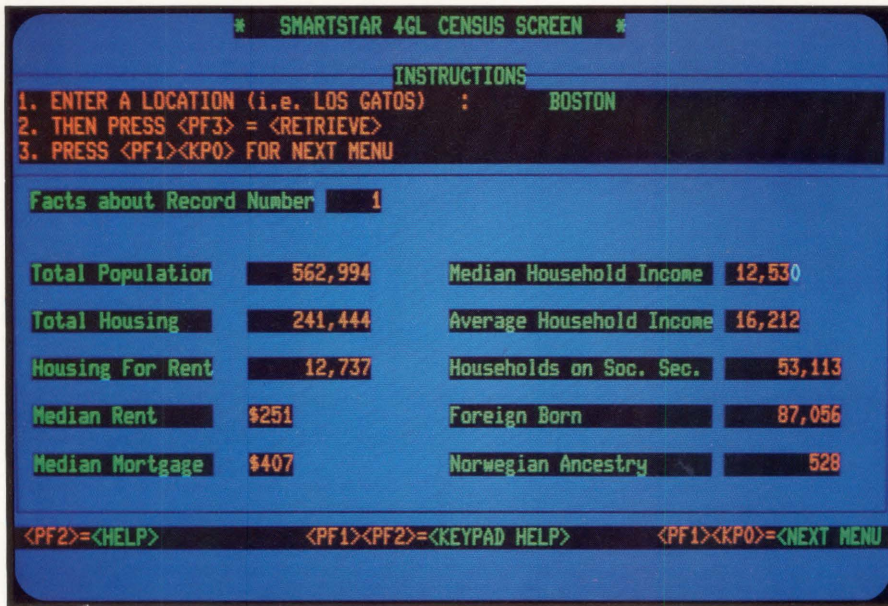

Screen 1: An example of the Smartstar product operating against a Census demonstration database.

to use the communication protocol that's common to the environment of the client machine; i.e., TCP/IP in the UNIX environment and DECNET in the VMS environment. The reason for this is operational.

It's possible to obtain products that speak TCP/IP from VMS or DECNET from UNIX, but forcing the use of a common protocol not only raises the cost of data sharing but increases the operational complexity. Each vendor will increase the performance of the communication protocol native to a particular environment and will test it thoroughly. Non-native protocols aren't competitive by comparison.

A third requirement is to use the application development tools and operating system tools of the native client system. VMS users should be able to use VMS tools; UNIX users should use UNIX tools. You can share data by terminal emulation or remote login to the system where the data is, but this forces you to learn multiple ways of doing things and tends to diminish the desired productivity gains. It's also counter-productive, because the application processing is in the wrong place. More applications are moving near the user. This allows sophisticated and friendly

user interfaces and local administration and support.

Appropriate administrative tools must be available to manage security, data authorization and resource management. When a valuable resource, such as corporate data, becomes available, there's the potential for abuse of the data or the engine that manages it. Without such tools, no organization will allow data sharing, as the exposures will outweigh the efficiencies.

The ability to tune the behavior of the data-sharing engine also is important. Inevitably, some of the applications will have response constraints that, if not met, will mean that the sharing idea can't be used. Tuning and resource management tools must be part of the system.

The data must be available, because if not, it will affect an entire community of users, and the more it's shared, the bigger will be its impact if it's not available. Lack of data availability for short periods isn't critical in some applications, but it's disastrous in others. The ability to configure and share redundant copies of the data go hand in hand with the data-sharing concept.

When a system offers these features, you can expect to realize the benefits of sharing data in a heterogeneous en-

vironment. Depending on the kind of data to be shared and for what purpose, different approaches are available.

Database Servers

What kinds of data do people want to share? They want the data they need to do their jobs effectively. In an organizational setting, this is the kind of data that's best stored in a relational database.

A database server fulfills database requests; i.e., database transactions. It functions as a server node on a network and communicates with client nodes using standard communication protocols. Figure 1 illustrates a VAX communicating over an Ethernet using the DECNET protocol, sharing data with a Sun workstation communicating over the same Ethernet but using TCP. A third workstation, a PC running MS/PC-DOS also shares data over the same network, possibly using the XNS protocol or a variant, such as the Novell protocol.

Within the server is a relational database management system. Within the clients is software that accepts requests from application programs and communicates these requests over the network to the server. The requests are represented in a common relational language, such as SQL. When the client receives a request, it processes the data as implied by the SQL statement and transmits the answer, which may consist of a few or a large number of messages, to the client machine.

Let's examine how the requirements are satisfied. The data is shared concurrently, and the data is consistent. The data is in one place, even though applications accessing it are distributed widely. In fact, the DECNET or TCP node could be far away, if gateways and internetworking are used.

The concurrency and consistency result, because today's full function database systems support the idea of a database transaction; i.e., a series of SQL statements from a shared viewpoint, executed as a unit. The systems contain a full concurrency locking and logging capability to ensure data consistency regardless of conflicts in access. The log-

ging mechanism ensures database consistency even if there's a machine failure.

Database servers isolate the details of the communication protocols in a separate portion of the system hardware and software. By the time the database transaction request reaches the main database software, the details of how this request reached the server software have been stripped away. It's possible to use many protocols and different physical communication media while still retaining the ability to share.

It's impossible to hide the nature of the client computer architecture from the server. Character strings are represented in different character sets (e.g., ASCII and potentially EBCDIC with IBM clients), floating point representations are different, and byte streams arriving from a client machine can reflect the byte ordering characteristics of the client (byte ordering in a VAX is different from an Intel 80xxx). The software has to be prepared to deal with these issues.

The software on the client side is running in the native operating environment of the client machine. To share data, it's necessary to have this software communicate through the Interface Library as shown in Figure 1. The entry points in this library allow SQL requests to be submitted, answers to those requests received, and status and exceptional conditions handled. There often are a number of utility tools provided as part of a standard package. Because of the high level of the SQL language and the rapid convergence of the ANSI SQL standard, it's not difficult to adapt a tool to this interface, provided it was built with a relational database in mind.

Administrative tools and availability features are paramount. The availability of these tools tends to vary from one vendor to the next, as that area isn't covered by the SQL standard. The SQL language provides GRANT statements for allowing certain users or user groups the ability to perform certain operations. The VIEW mechanism of the SQL language allows a database administrator to restrict a user from viewing or manipulating certain restricted columns,

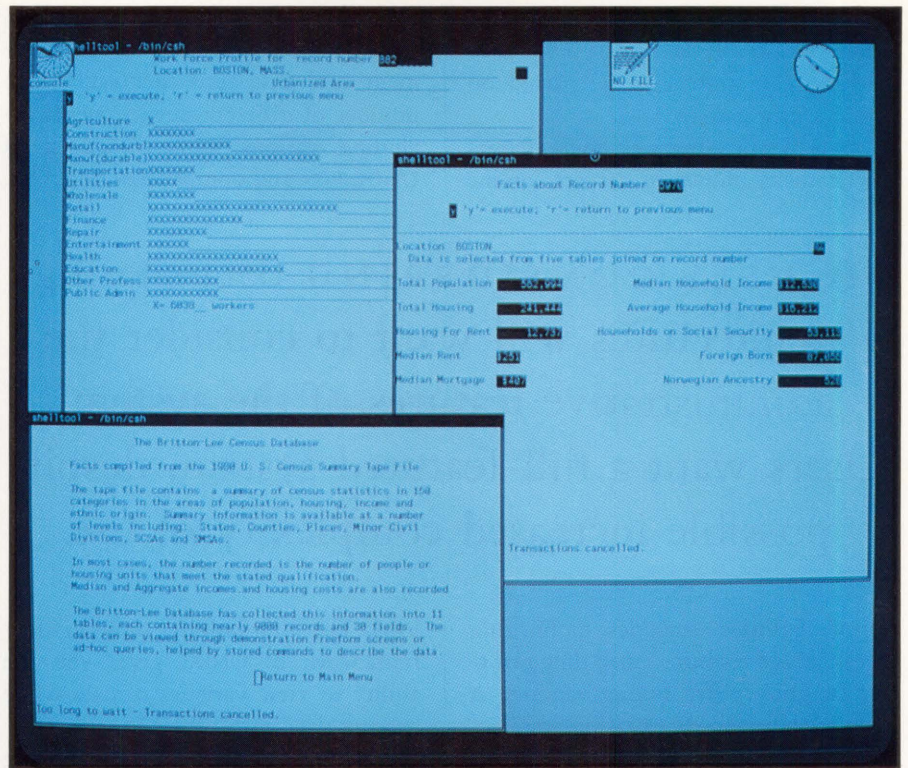

Screen 2: Screen being developed using JAM, the JYACC Application Manager running on a PC.

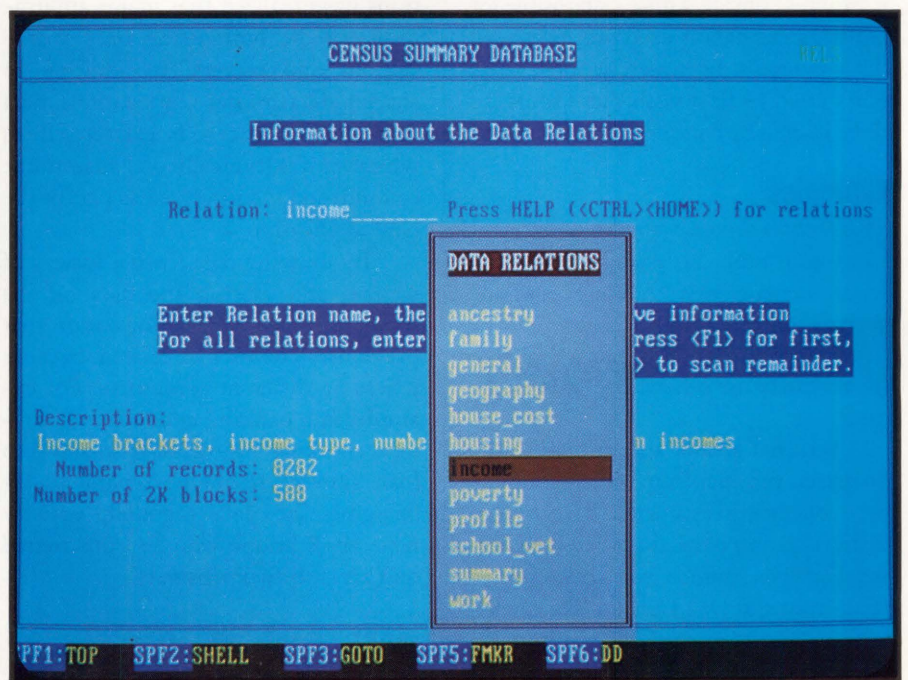

Screen 3: Screen being developed using JAM, the JYACC Application Manager running on a PC.

and the restrictions can be on a value basis. Using GRANT and VIEW statements, restrictions can be placed on what a user can do.

Availability features, such as mirrored disks, duplexed servers, online

is Freeform from Dimension, a portable, screen-oriented application development tool that runs identically in a number of different environments including various implementations of UNIX, PCs and compatibles and VAX/

A file is a collection of data whose semantics are known to one of a few applications. The definition of the data is with the program that uses the data, not with the data and separated from any particular use. This is the difference between file and database processing.

File servers know about files; i.e., how to open them, close them, provide pages or records from them, etc. A file server generally doesn't know about the internal field structure nor whether there's a data manipulation language, such as SQL, that can be used to search for data by content. Searching by content occurs in the processing program, not in the file server.

File servers are useful when the unit of sharing doesn't depend on this knowledge of internal data structures or when there's little searching to do. For example, program libraries rarely are searched by content, and normally the whole program module is accessed by the loader. To maintain consistent, shared copies of program libraries, a file server is a perfect choice. Document libraries accessed by a word processor are accessed in their entirety, and there's little, if any, searching to do in the file server when accessing a document. A file server will do the job.

But when the unit of sharing is a piece of a database, there are different requirements. Usually, the size of the database is larger than the size of a file holding any particular program or document. If the system moved the entire table in a relational database across the network to the database search software running on the workstation, this would be slow and clog the network for other uses.

It makes more sense to move the database processing software onto the server. To do this, you must have knowledge of the data on the server, not in the applications. Even when the database software is moved to the server, it's important to minimize network traffic. Relational systems are the only kind of database software systems that fit this requirement. Previous database technologies were more navigational in that

A USER CONSIDERING data sharing architectures will want to consider the administrative features of the system. Users want a full-featured system, despite possible increased complexity of use.

dump facilities, statistics monitoring facilities and resource scheduling priority facilities, differ among vendors. A user considering data sharing architectures will want to consider the administrative features of the system. Users want a full-featured system, despite possible increased complexity of use. As data sharing becomes more widespread, it requires control. Those responsible for ensuring the data is used properly need these controls. Fortunately, most users don't need to deal with these tools, so their increased complexity is localized.

Examples

This section shows examples of different front-end tools accessing a database server concurrently. A static example, such as this one, fails to convey that the data updated by one client is available immediately to others, but this is the case.

Screen 1 shows an example of the Smartstar product from Signal Technology, operating against a Britton Lee demonstration database called the Census Database, which is a collection of facts from the 1980 Census. The screen is a combination of five separate relational tables, combining facts about Boston.

Screen 2 shows screens from the Census database running on a Sun workstation. The tool used in this screen

VMS. The multitasking, multiwindow framework of UNIX, gives you the ability to view varieties of data while sharing data with others.

Screen 3 shows a screen being developed using JAM, the JYACC Application Manager running on a PC. As PCs and workstations have become widely used and networked, organizations have realized that major applications can be built using only workstations and servers. In addition to sharing data among workstations, data sharing allows data to be extracted from wherever it is (typically on a mainframe or mini) and incorporated as part of the new application.

By drawing data from a variety of sources and placing the data on the server, you can relate information that previously couldn't be related, because it was on different computers. For example, in a banking situation, the savings, checking, mortgage, trust and auto loan systems might be separated. By bringing the data together, entirely new applications can be constructed quickly and inexpensively.

What About File Servers?

How is data sharing using a database server different from using a file server? The answer lies in the kind of data being processed and the division of computer resource that results.

THE NEW MASTERMIND OF MONITORING

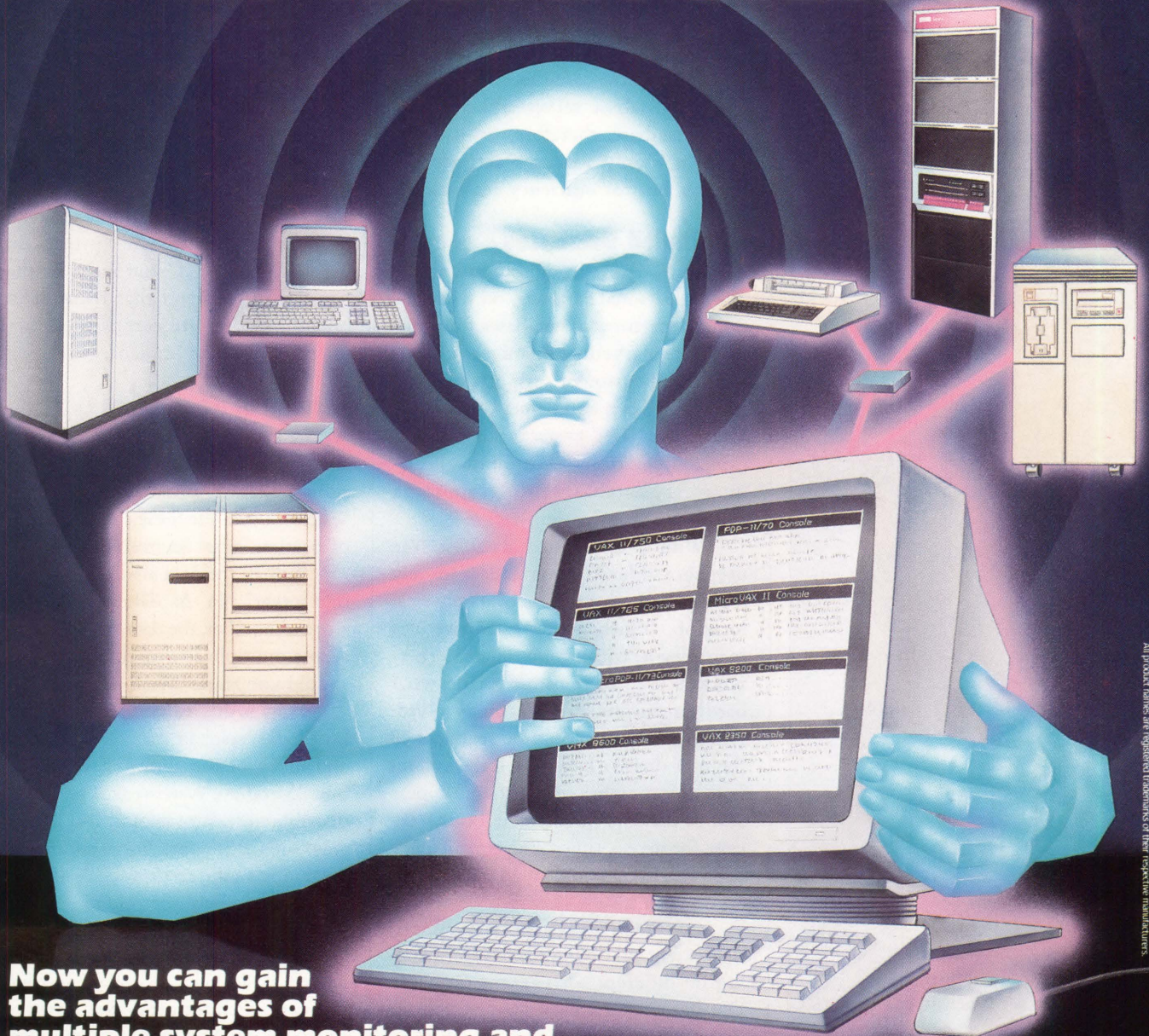

Now you can gain the advantages of multiple system monitoring and control from a single location.

Maintech introduces "Master Console," an innovative product from Volt Delta Resources that can streamline your operation and effect major savings.

With Maintech's "Master Console" you can monitor and control up to 8 DEC processors from a single location. Through a dynamic windowing process, "Master Console" creates a scrolling mini-terminal for each processor, all on a single high resolution monitor. The immediate benefit to management: centralized control, elimination of stored console logs and huge gains in individual productivity.

Other cost efficiencies are gained by eliminating the space requirements and clutter of consoles and console printouts on the computer room floor. Equally impressive, "Master Console" lets you archive your console logs on tape and prints out what you want to see.

Other features:

- Supports PDP, MicroVAX and VAX systems
- String search for user defined critical messages
- Audible and visual alarm and prioritized error reporting
- Concurrent local console operation
- Tiled windows and special purpose function keys
- Console log with scrolling, historical archive and restore

For your convenience, hardware leases and purchase plans are available.

"Master Console." Another powerful product from Maintech, the innovative leader in the independent service marketplace.

MAINTECH
GUARDIAN MAINTENANCE SERVICES
A DIVISION OF VOLT DELTA RESOURCES INC.
1 800-426-TECH
1133 Avenue of the Americas
New York NY 10036
212 827-2600
A VOLT INFORMATION SCIENCES COMPANY

All product names are registered trademarks of their respective manufacturers.

users traversed specified paths to associate different parts of the database. Even now, such a mode of access has some appeal, as shown by the current popularity of hypertext systems.

But from a server architecture point of view, it would be an impossible situation to send a pair of network messages for every traversal across every link when searching for data. A way is

needed to express search requirements in an access path independent way, such that a relatively short message can trigger a large amount of processing on the server. SQL and the relational model fit this requirement exactly. No other database model has demonstrated its ability to do this at the same level. The concepts of database server and the relational database, therefore, go hand in hand, not only for user accessibility reasons, but for efficiency reasons.

Distributed Databases

Databases exist throughout any company in personal databases on workstations; departmental databases for functions like marketing, finance, manufacturing and customer support; regional databases when companies are regionalized; databases overseas for international operations; corporate headquarters databases for reporting regulatory information, etc.

With a distributed database, the user should have access to data for any legitimate use regardless of its physical location, which vendor's software is managing it, which communication network is used to transmit it, and what hardware incompatibilities are involved. Also, the access should be seamless so the user doesn't have to tell the system how to accomplish this; it should appear as if all the data were stored locally (except for access times and concurrency delays). This is a noble goal. Who could argue with it?

Of course, no system can do this to that extent. Various vendors are working on different parts of the problem. Database experts have defined various key points that they feel the ultimate distributed database should meet. There are difficult technical problems to be solved to realize this goal:

1. The various data dictionaries in a heterogeneous environment must be reconciled.
2. If data changes must be accommodated, rather than only queries, the system must handle advanced locking, deadlock detection and transaction commit protocols.

3. If there are multiple communication networks involved, there are the problems of administering a large, potentially multivendor network.

4. The problem of administering on a distributed basis all the access to various kinds of data, and the problem of predicting and controlling the impact on network and computer resources of all this unpredictable data access, are frightening to database administrators.

It seems that distributed databases are everyone's goal, but there are many lessons yet to be learned. I predict that users will proceed cautiously, as they come to understand that truly distributed databases are complicated, both for machines and humans.

Trends For The Future

We have seen examples of how data sharing is possible today. But, extensions are clearly possible and desirable. Who will provide these and what kinds of barriers must be overcome?

Will all the data always be on only one server? No. As databases grow in size and number, the data should be split across multiple servers and the servers should cooperate when necessary.

How is this different from a distributed database? In many ways it isn't, and many of the algorithms in distributed database systems will be used in distributed server systems. But in some ways, it's different. For example, the need to have the servers speak differing network protocols or able to deal with differing server architectures is less compelling than the need for the clients to speak different protocols and have different architectures. By having a relatively small (a few to a few dozen) server serving hundreds or thousands of clients, it's possible to blend the two technologies in complementary ways.

Another development that seems inevitable is that file servers and data servers will cooperate more fully than they do now. Whether file servers and database servers merge into a common server is a matter of technical debate at the moment. But the ability to combine relational data and other less highly

Companies Mentioned In This Article

Britton Lee Inc.
14600 Winchester Blvd.
Los Gatos, CA 95030
(408) 378-7000
CIRCLE 566 ON READER CARD

Dimension Software Systems Inc.
1717 Walnut Hill Lane, Suite 104
Las Colinas, TX 75038
(214) 580-1045
CIRCLE 533 ON READER CARD

Intel Corp.
3065 Bowers Ave.
Santa Clara, CA 95051
(408) 987-8080
CIRCLE 534 ON READER CARD

JYACC Inc.
116 John St.
New York, NY 10038
(212) 267-7722
CIRCLE 535 ON READER CARD

Novell Inc.
122 East 1700 South
Provo, UT 84601
(801) 379-5900
CIRCLE 536 ON READER CARD

Signal Technology Inc.
5951 Encina Rd.
Goleta, CA 93117
(805) 683-3771
CIRCLE 537 ON READER CARD

Sun Microsystems
2550 Garcia Ave.
Mountain View, CA 94043
(415) 960-1300
CIRCLE 538 ON READER CARD



Our front end helps protect your back end.

Today's users require sophisticated interfaces for their applications. Yet complex front ends are a real pain to create, especially when the specs change and your deadlines don't.

But now JYACC introduces JAM™, a powerful user interface development tool that makes it easier than ever to design and revise your complex applications.



Use windows and colors freely with JAM.

JAM is the first tool that does it all, from prototyping to implementation. With JAM, you start by creating screens and linking them together to develop an application shell. You can experiment with the look of the interface, and even explore "what if" scenarios on the application flow. Then you attach processing routines, and your application is complete.

JAM works under the following operating systems:

- UNIX®
- VMS®
- RMX™
- MS-DOS®
- XENIX®
- VOS™
- AOS/VS™

You'll be amazed at how quickly your applications spring to life with JAM's interactive screen management utility. You can use features like context-sensitive help, shifting and scrolling fields, a variety of visual attributes and extensive data validations to create exciting screens, windows and menus—all without writing a single line of code. JAM also lets you test your prototypes at any time.

JAM lets you draw from its extensive subroutine library to help you write processing routines faster. And revisions to your applications are easier,

because your subroutines are insulated from the data entry and presentation details of the interface.

JAM is extremely portable. It runs on almost every computer, from PCs to superminis, and works under 6 operating systems. This allows you to develop consistent interfaces throughout your company—a significant asset to the Fortune 500 companies that have been using JAM for more than a year.



Enhance applications with context-sensitive help.

JAM from JYACC. It gets your front ends—and back ends—in great shape. Call for more information about JAM and our demo diskette. **800-458-3313** JYACC FORMAKER™, JAM's screen manager, is also available separately. JYACC, Inc., 116 John Street New York, NY 10038 212-267-7722

Introducing JAM

JYACC Application Manager. *The Composer for Sophisticated Applications.*

CIRCLE 131 ON READER CARD

JYACC

Excellence in Systems & Application Design

structured data is desirable, and there are many advanced development projects exploring this.

The development of standards and

forts in all these areas. How fast these separate efforts are brought together depends on how quickly the user community demands that it happen. More

HOW IS DATA SHARING using a database server different from using a file server? The answer lies in the kind of data being processed and the division of computer resource that results.

open interfaces in the areas of computer-to-computer communication, database languages, operating system environments, data interchange formats and data dictionary representations are required to achieve the kind of data sharing users need. There are standards ef-

vendors are realizing that users want commitment to standards and open interfaces, but few vendors have committed to all the standards that will be necessary for ultimate data sharing.

There also will be a need for additional system integration. It's possible

for competing vendors to meet a given standard and still be unable to share data in a meaningful way. It's often in the interest of a given vendor to make it difficult for a customer to replace one offering with a competitive one. Thus, the role of the system integration company, specialists in making a variety of heterogeneous systems work together, will become more prominent.

Larger companies will take on this role themselves. Smaller companies will depend on vendors of packaged systems to work out these problems. The good news is that data sharing in a wide variety of environments seems unstoppable, and the end users will benefit. — *Robert W. Taylor, Ph.D., is senior vice president of Strategic Partnering at Britton Lee Inc., Los Gatos, California.*

ARTICLE INTEREST QUOTIENT
Circle On Reader Card
High 530 Medium 531 Low 532

THE OEM GUIDE TO BETTER UNIX CONNECTIONS

We can help you sell into IBM environments. Here's how. Our VAX Link products provide you with an integrated family of communications software for connecting VAX and MicroVAX systems to IBM mainframes and minis. Both VMS and ULTRIX versions are available.

How to Get to Market Faster

Our free, customized training and support programs include application development assistance to speed up your efforts. And, with our special programming tool kits, your development time is cut dramatically.

How to Reduce Your Sales Cycle

It's easy. Simplify the purchasing decision. Offer a single, bundled solution—including both application and communications software. By making VAX Link an integral part of your product, your customers will only need one vendor. You.

How to Expand Your Market

With VAX Link, you can enhance your products to include those features demanded by the vast installed base of IBM users. VAX Link provides pure IBM compatibility for your DEC systems. The connection is completely transparent, requiring no changes on the IBM side. Since Systems Strategies is the leading developer of IBM communications software, you can be assured that the latest IBM technology, such as NetView and LU6.2/PU2.1, will always be available.

The VAX Link family includes: SNA/3270, SNA/RJE, BSC/RJE, API/3270 and TCP/IP support. When you select Systems Strategies, you get more than a product. You also get our commitment to the success of your product line.

Call Us: 212 279-8400

Or Write Us At:
Systems Strategies Inc.
225 West 34th Street
New York, NY 10001

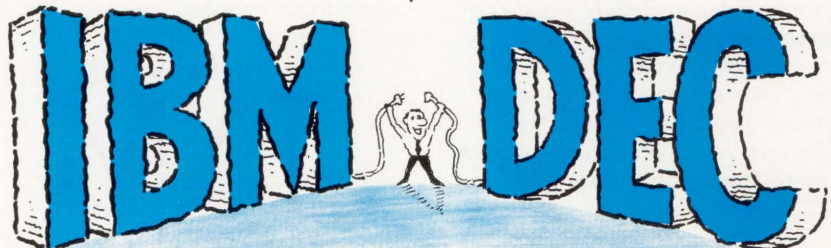

VAX Link from Systems Strategies
an AGS Company

The best connections in the industry.

IBM and NetView are trademarks of International Business Machines Corporation. DEC, VAX, MicroVAX, ULTRIX and VMS are trademarks of Digital Equipment Corp.

COLORSCAN[®]/2 Workstation

*VAX access
and PC applications.
Hmmm!*

One big idea in one small space.

The COLORSCAN/2 color graphics workstation "is an idea whose time has come," reported *Digital Review*. It fits two capabilities - VAX[™] access and the ability to run PC applications - into one very small, low-profile enclosure with quiet, diskless operation.

It's a built-in plug-compatible VT[™]200 text/color graphics terminal for all your VMS[™] and UNIX[®] information access. And it's a high-performance MS-DOS[®] personal computer for today's business applications. All in one sleek ergonomically-designed desktop workstation.

There's more, too. Parallel VT200 and MS-DOS operations. ReGIS[™], Sixel, Tektronix[™] and EGA plus-compatible color graphics (640 × 480 × 16 resolution). Built-in cut and paste. Full 132-column display.

In other words, "The COLORSCAN/2," according to Frank J. Derfler, Jr., editor of *PC Magazine*, "is an excellent solution to desktop clutter for any combination of PC, LAN-based and host-based applications."

To find out more, call Datamedia at 1-800-DMC-INFO.

Unretouched screen
10 × 15 × 2.5-inch base unit

COLORSCAN is a registered trademark of Datamedia Corporation. VAX, VT, VMS and ReGIS are trademarks of Digital Equipment Corporation. UNIX is a registered trademark of AT&T Bell Laboratories. MS-DOS is a registered trademark of Microsoft Corporation. Tektronix is a trademark of Tektronix, Inc.

DATAMEDIA CORPORATION
The Positive Response[™]

11 Trafalgar Square, Nashua, NH 03063
CIRCLE 189 ON READER CARD

A BETTER UNIX

for the

PDP-11

THE 2.10BSD UNIX operating system offers

enhancements over 2.9BSD. BY DONNALYN FREY

THE COMPUTER SCIENCE RESEARCH GROUP (CSRG) of the University of California at Berkeley, recently released 2.10BSD, a new version of the 2.9BSD UNIX operating system for PDP-11 computers.

The 2.10BSD has been written as a basic port of the 4.3BSD UNIX operating system for PDP-11 computers. The CSRG chose to make 2.10BSD compatible with 4.3BSD to allow networking between the operating systems, and because 4.3BSD is a reliable, fast and efficient operating system. Compatibility with 4.3BSD also allowed applications to be ported easily and internetworked between the two operating systems. In addition, it's an inexpensive upgrade to the UNIX operating system for sites not running UNIX on their PDP-11 computers and is the fastest operating system available for the PDP-11 computer.

The 2.10BSD operating system was

written by Keith Bostic of the Computer Science Research Group of the University of California at Berkeley, and Casey Leedom of the California State University, headquartered in Long Beach. The two programmers wrote it in 10 months of intensive full-time effort, devoting three man-years of effort to the project.

New Features

The 2.10BSD has several new features beyond the 2.9BSD system. These features include 4.3BSD TCP/IP networking, a 4.3BSD source code hierarchy, 4.3BSD system calls, symbolic links, a random access memory (RAM) disk and many new peripherals. Supported networking hardware includes ACC and DEC/CSS IMP Interfaces, 10M bit/s Ethernet (for three different controllers), 3M bit/s Ethernet and Proteon PRONET. Serial line IP (SLIP) is also available. Net-

working support is available only for machines with supervisor mode and separate instruction and data space.

The 2.10BSD compiler has been improved to produce faster code and to handle more C functionality, including the void type, various unsigned bit fields and global structures with identically named elements. The 2.10BSD allows programs to have up to 15 text overlays, permitting much larger text spaces than previously possible. The 2.10BSD has benefited from the extensive work done by the CSRG with 4.3BSD to make the kernel code cleaner and the system faster and more efficient.

Providing 4.3BSD compatibility in 2.10BSD has many advantages for sites running 4.3BSD. The different operating systems now can run the same networking protocols and software and, with minimal changes, the same applications software. The list of changes made in

There's training...



and then there's **TRAINING!**



It's simple: the more experienced the training facility, the better the learning experience. And for years TRW has been the undisputed leader in alternative DEC training, achieving a solid reputation for the highest quality instruction at very reasonable prices.

Hardware Maintenance Training

TRW's wide curriculum of hardware maintenance courses provide real world ability to solve real field engineering problems and minimize system downtime. From basic VAX concepts through VAX 8000 series processors, TRW's practical, comprehensive courses serve many of the world's largest in-house service

organizations—as well as third-party maintainers.

VMS and UNIX Training

That same in-depth experience and expertise marks TRW's range of VMS and UNIX courses for system maintainers, users, operators and managers. All hardware and software courses are available on-site or at TRW's fully equipped Virginia training center. And when your operations or applications are unique, TRW can design and conduct courses tailored to meet your specific training requirements.

Call or write today for a comprehensive catalog of TRW's hardware and software course offerings, or for information on

other support services available from TRW. Rely on the leader to put you on the right track to quality training.

TRW Technical Training Center

420 Hudgins Road
Fredericksburg, VA 22401

1-800-255-3029

In Virginia Call: 1-703-898-3878

DEC, VAX, PDP are trademarks of Digital Equipment Corporation. UNIX is a trademark of AT&T. Trademarks are used solely for identification purposes.

CIRCLE 165 ON READER CARD

2.10BSD

USENIX Association
 P.O. Box 2299
 Berkeley, CA 94710
 (415) 528-8649
 electronic mail:
 {uunet.ucbvax}!usenix!office
 CIRCLE 519 ON READER CARD

2.10BSD to create this compatibility is extensive; here are some of the major changes:

1. All the 4.3BSD system calls, such as mkdir() and rename(), were ported to 2.10BSD. This also includes signal facilities, time-of-day calls, file locking, multiple groups and expanded ioctl functionality. This allows code written for 4.3BSD to run almost unmodified on 2.10BSD.
2. The 4.3BSD C library was ported directly to 2.10BSD. This allows code written for 4.3BSD to run unmodified on 2.10BSD.
3. Approximately 95 percent of the 4.3BSD application program suite was

ported to 2.10BSD, allowing 2.10BSD to handle programs that were written for 4.3BSD.

4. The addition of symbolic links to 2.10BSD provides 2.10BSD with environmental compatibility with 4.3BSD.

Besides making 2.10BSD compatible with 4.3BSD, its kernel speed was increased. Some of the major changes are:

1. Clists are doubled in size and faster. Clists are the structures that contain the characters entered through serial lines; e.g., from a user's terminal. The bigger structure allows the operating system to devote less time to copying and changing clists. The kernel routines that manipulate the characters inside the clists were completely revised for speed.
2. In-core copies of file system inodes now contain the access, modify and change times. This results in major speed improvements in programs, such as Make, that repeatedly access the modification times of files.
3. Process ID hashing was added. In 2.9BSD, the process IDs were stored in a large array. To allocate a new process

ID, or to find a current ID, the program had to step through this array, a fairly slow process. The 2.10BSD uses a hash table to locate current process IDs quickly and maintains a list of available process IDs for quick ID allocation.

4. New, fast routines were added for copying data in and out of kernel space. The 2.9BSD and other older versions of UNIX transferred characters one at a time to or from user space and required multiple subroutine calls per character. In 2.10BSD, transfers are done in large chunks. For large transfers, kernel mapping is altered to allow direct memory-to-memory copying.

5. Programs now are cached in memory. After a program is loaded into core memory, it's retained until that memory is required for another purpose. On PDP-11 computers with large amounts of memory, this results in speed improvements. A cached program begins running in approximately one-seventh the time required by previous UNIX versions.

The 2.10BSD UNIX operating system will run on most PDP-11 computers. Because of a much larger kernel and various data space and speed trade-offs, it's intended for use with the PDP-11 44/53/70/73/83/84. A minimum of 1 MB of memory is recommended for reasonable performance.

The 2.10BSD operating system from Berkeley CSRG is being distributed by the USENIX Association. The release isn't supported by the CSRG. However, updates to 2.10BSD may be forthcoming.

Although it's an unsupported release, users with technical questions on the 2.10BSD operating system can contact Keith Bostic of the CSRG by electronic mail at keith@okeeffe.berkeley.edu or by telephone at (415) 642-4948. *Author's note:* The author wishes to thank Keith Bostic of CSRG, who provided much of the technical information included in this article. —Donnilyn Frey is technical writer for Frey Communications in Fairfax, Virginia.

UNIX[®] SYSTEM ADMINISTRATION

UNISOL[™] UTILITIES

The cost effective solution to system management problems

.....**Establish and maintain a consistent and secure environment**

.....**Control Computer Costs**

- **System Operation and Maintenance**
- **Resource Accounting and Chargeback**
- **Security Monitoring and Control**
- **Network Administration**

UNISOLUTIONS ASSOCIATES

6520 Green Valley Circle
 Suite 13-203
 Culver City, California 90230

Call (213) 641-6739

Unix is a registered trademark of AT&T
 © 1988 Unisolution Associates. All rights reserved.

ARTICLE INTEREST QUOTIENT
 Circle On Reader Card
 High 516 Medium 517 Low 518

NEW SL-GMS (3.0)

THE SIMPLEST PATH TO DIRECT GRAPHICAL MODELING

- Animated visualizations of processes and information
- Coherent binding of graphics to your dynamic database variables
- Rapid screen and interface development for preview and production
- Compatible with GKS, CGI, IRIS GL, X and DECwindows

The Sherrill-Lubinski Graphical Modeling System (SL-GMS 3.0) is an off-the-shelf software product designed to speed up your development of interactive graphics. With it you can build your own screens, displays or custom graphical interfaces.

Helping you at the lowest level

SL-GMS is fully compatible with standard graphics packages such as GKS, CGI, IRIS-GL, X Window and CORE, among others. Normally to exploit the versatility of standard packages a great deal of code has to be written to control the graphics functions at the low level. SL-GMS eliminates this step to give users unprecedented speed and directness. Without time consuming development or study of low-level graphics functions you can easily create anything from simple screens to fully articulated dynamic visualizations.

SL-GMS handles the tasks of creating, modifying, saving, filing and displaying graphics. All calls to standard display packages are made for you by SL-GMS.

Your screens can be driven from a great variety of data streams such as external real-time sources, direct conversational input, deeper underlying models, mathematical expressions and from SL-GMS scripts for quick design evaluation and simulation.

SL-GMS supports 2D modes of operation in an integer coordinate system. It has all standard graphics primitives, including splines and bit maps, and offers hierarchical models and groups.

This high-level graphics management approach takes all the time and work out of handling graphical data objects. As a result you write much simpler programs to bring up screens, make changes and access objects by names you choose.

Using SL-GMS Development tools

The **Graphical Model Editor** (SL-DRAW) is shown above, composing a process visualization screen. SL-DRAW allows you to edit, modify, combine and file screen icons and objects which are supplied by SL-GMS—or you can easily create your own. By making appropriate menu selections or by drawing with the mouse, display screens are composed effortlessly. Attributes such as line style, width, and color may be quickly selected or changed. Objects can be moved, scaled, rotated, or mirrored. Libraries of user-defined graphics symbols may be created and referenced from many different screens.

In its dynamics mode SL-DRAW contains additional menu options which allow you to make direct associations between the iconic objects on a screen and variables in your data base. The coherent binding of icon to dynamic variable is instantaneous. The dynamic behavior of each object may be completely specified from the editor and is stored with the objects when they are saved on disk. From SL-DRAW you can also engage "GMD-run", a Preview Utility which lets you animate and evaluate your screen displays without leaving the editor. This entire construction process of your user-interface is completely codeless.

As an alternative The **Graphical Modeling Language Interpreter** (SL-GML), may be used to exer-

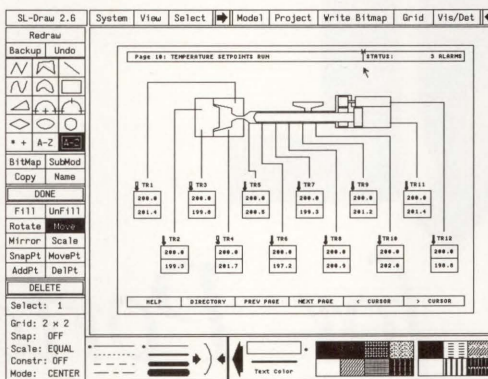

cise different screen scenarios. Using the simple SL-GMS command language, screen data files may be loaded and redisplayed. Sequences of attribute or position changes may be applied to objects by name. This allows you to experiment easily with the look and feel of graphics screens before binding the screens to your real-time program variables.

SL-GMS Run-Time Module

While written in C, SL-GMS is uniquely hospitable to other languages and code. It is extremely adaptable and its run-time module configured by development tools, is easily embedded, in part or in whole, in a user's application program. This module consists of elements from the **Graphical Modeling Function Library** (SL-GMF), which consists of all the functions needed to impart and alter the attributes of objects or icons you have created with SL-DRAW. The **Graphical Model Dynamics Library** (SL-GMD) contains a powerful set of procedures and functions to support the codeless binding of icons as they are created with SL-DRAW directly to application variables. The automatic invocation of these functions permits the change of any or all icon attributes, e.g., shape, appearance, size, color, position, orientation, visibility.

SL-GMD also allows formulas and expressions of variable combinations to control icons and displays.

Creating graphics display screens in this way eliminates the work necessary to attach even complex graphics to your applications. This is especially true if your requirement must maintain compatibility with graphics standards.

The system contains a separate object layer called SL-GWS—Graphics WorkStation function library—to ensure and simplify the transportability of SL-GMS to the widest variety of systems and devices.

SL-GMS Architecture

SL-GMS is a solid and robust environment. It is a true, object-oriented, integrated, coherent, hierarchical-modeling system with all its components—SL-DRAW, for example—built up from combinations of its own graphics primitives and from functions in the SL-GMF library. These functions are organized according to classes and subclasses.

SL-GMS has particular value to many

developers because of its strict underlying architecture, managed and controlled by the Object-Oriented Environment (SL-OOE). This is itself a library of versatile object-management functions, used within SL-GMS, and which is made accessible to interested users for application program development. SL-OOE also contains a program utility to define the user structural-framework and organize program code into strict hierarchical classifications. SL-GMS uses run-time class-information to provide the functionality present in object-oriented programming systems, such as messages to objects, dynamic binding, encapsulation, class inheritance, and so on. SL-OOE does not require the use of any language extensions or any special compilers.

Useful object management functions include: 1) an automatic facility for debugging and tracing function calls invoked on every object, 2) automatic archival and retrieval of arbitrary data structures, and 3) automatic "dumping" of object data.

SL-OOE together with (SL-GMF) can be seen as functionally similar to the emerging Programming Hierarchical Interface Graphics Standard, PHIGS. However, SL-GMS is much more extensible than PHIGS with the same functionality, and SL-GMS contains the editor SL-DRAW and the coherent-binding capability. But SL-GMS can easily interface to PHIGS through the SL-GWS layer for users with this requirement.

Complete SL-DRAW source-code is offered at a low price, so that you may customize the editor to your particular requirements. For example, you may want to change the layout of SL-DRAW menus, or offer a different set of attributes or primitives to the user.

License Prices and availability.

Development Configurations		Components
SL-GMS	\$ 9,500	(SL-DRAW/GML/GMF)
SL-GMS-D	12,500	(above, plus SL-GMD)

Run-Time Licenses (Optional)		
SL-GMS	\$ 2,400	(SL-GMF)
SL-GMS-D	3,600	(SL-GMF plus GMD)

Source code (Optional)		
SL-DRAW	\$ 9,500	
SL-GML/GMF	55,000	
SL-GMD	20,000	

Available: UNIXbsd 4.2, 4.3, System V, Ultrix, DEC-VMS
GKS level 2c (DEC Version 3.0 and others)
CGI, CORE, IRIS GL, X Window, DECwindows
Silicon Graphics IRIS 40/70, SUN3, SUN4, VAX, MicroVAX

Call or write today.



Sherrill-Lubinski
Suite 110 Hunt Plaza
240 Tamal Vista Boulevard
Corte Madera, California 94925
415/927-1724

SQL

for Portability and Integration

STRUCTURED QUERY LANGUAGE provides a common language to access relational databases and offers portability for applications and data. BY SCOTT KITAYAMA

INTEGRATING APPLICATIONS AND DATA between VMS and ULTRIX operating systems has become an important issue for a growing number of users. DEC licensed ULTRIX to 15 percent of VAX machines in 1987, and the percentage is growing. Today, as many DEC engineers work on ULTRIX as on VMS.

The growth of ULTRIX and the popularity of UNIX are forcing users to look at the integration issue. A mixed UNIX/VMS site may be justified either as a transition phase or as a solution in itself when different machines serve different user needs.

Integration should be examined at

two levels: application portability and data integration. Differing machine architectures and operating systems require application portability. Often, portability is addressed only after the application is built with a specific environment in mind.

Determining portability in advance implies that trade-offs are necessary. For example, C language makes sense for a portable application but provides insufficient power to do input/output (I/O). In the VMS environment, developers commonly use C with RMS, the VMS record management access method that allows data to be stored as distinct

records and accessed through an ISAM index.

But RMS doesn't exist outside VAX/VMS machines and because using C alone is unpromising, the choice is to write all data access code from scratch or find tools as portable as C. The emerging solution is Structured Query Language (SQL). The same on all machines, it allows the application to access the database, which takes care of definition, storage, recovery and security, and allows multiple users to share data.

SQL shares many of C's characteristics. It's portable and powerful.

Figure 1.

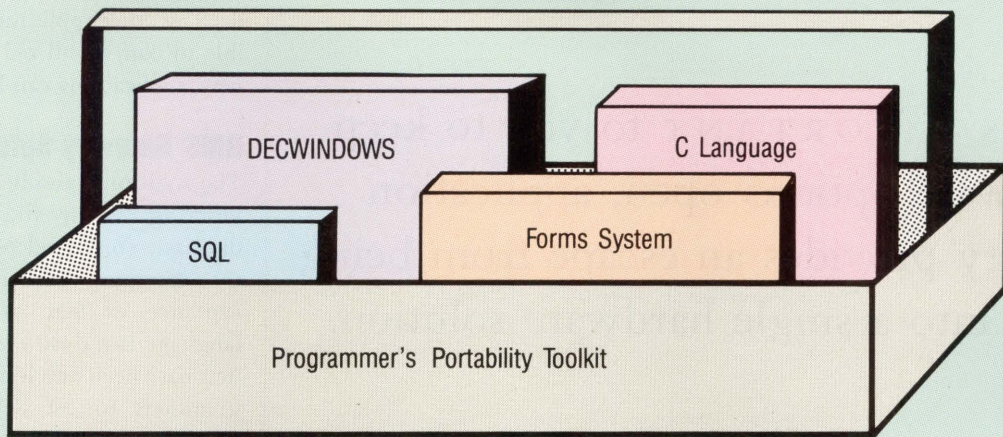

Portable tools allow the programmer to write applications that can run on both VMS and ULTRIX.

Because of its popularity and that of databases, it's found on machines ranging from micros to mainframes.

Forms Systems

With SQL, the problem of better I/O handling is half solved. Forms systems address the other half; i.e., screen management tools required for user in-

terface. Again, the programmer must decide whether to use what the development machine provides or look for portability.

C doesn't provide a portable means of sophisticated screen management. FMS, TDMS and SMG system services do in VMS, as do TERMCAP and TERMINFO in UNIX. As with data management,

VMS and ULTRIX deal with screen management their own way and aren't portable to each other.

In the ASCII terminal world, a number of companies provide forms systems to both VMS and ULTRIX. How well do they integrate with C and SQL?

Most relational databases are provided with a forms package along with

Figure 2.

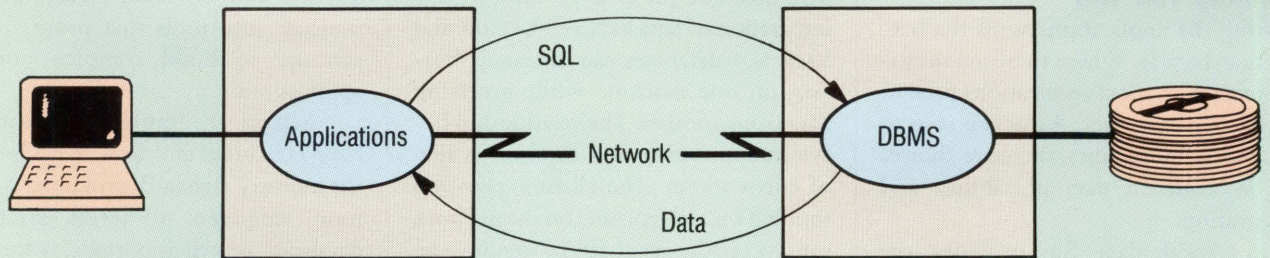

The architecture of SQL databases allows the separation of the application and the database. This allows the application to run on ULTRIX and get data from VMS or vice versa.

the SQL database. This is a convenient way to manipulate the I/O format without writing a great deal of code.

If the display is on a workstation, DECWINDOWS provides a good way of

is local. This makes the network transparent and allows applications on different machines to share data.

How can this be done while maintaining application portability? In VMS,

IF IT'S IMPORTANT to you to keep hardware options open, application portability provides an escape from being locked into a single hardware solution.

handling bit-mapped display. DEC has decreed that the X Window System will be window manager for VMS and ULTRIX and that the DECWINDOWS toolkit also will be available for both environments (see Figure 1).

Writing portability applications requires some choices to be made in advance. Standard tools provided on one system may not exist on another. Portable tools are available but usually not from the hardware vendor (a way to prevent users from switching to different machines).

If it's important to you to keep hardware options open, application portability provides an escape from being locked into a single hardware solution.

Winning The War

Porting the applications wins the battle, not the war. Where there are multiple machines, most applications need to access or share data. As in the case of application portability, there are choices to be made in data portability and integration.

A local data file provides the simplest case for integration and portability. But applications call for data that must be accessed remotely or shared with another machine. From the application programmer's standpoint, the best solution is to assume that the data

clusters allow machines to access the same disks. Disks are shared among machines, and any machine can access any file as if it were local. In the ULTRIX and UNIX environments, the Network File System (NFS) has become a de facto file-sharing standard. NFS permits file systems from a remote machine to be accessed as a local disk.

Both clusters and NFS provide data location transparency and allow different machines on the network to share data. This provides great capabilities to the application programmer, because the network is transparent to you. Unfortunately, clusters support only VMS machines, and VMS files can't be accessed by NFS.

The SQL

SQL could be the best solution for the integration of data between ULTRIX and VMS. SQL databases can run an application on one machine while accessing data from another. The relationship between application and database is that of client server. The client/application running on any machine on the network can access the database by sending an SQL inquiry to the server machine. Because this architecture isn't tied to a specific operating system, it can work on any VMS/ULTRIX combination (see Figure 2).

Using the same code to access data

on local and remote machines solves both portability and network access problems. Although it may be a solution for new data, it's not convenient for applications where data exists in files used by other applications. It's not feasible to convert all old applications, so new applications can be portable.

RMS Gateway Solution

The solution could be to allow SQL to work against any file, not a relational database. This broadened access for SQL is an emerging technology. Because acceptance of SQL as a data access language is industrywide, some products have been developed allowing programmers to use SQL against non-relational databases, non-sequential and sequential files.

Gateway technology isn't a total solution, because it doesn't solve the user's need for data locking and security. SQL technology will grow more sophisticated and, in time, provide access not only to relational databases, but also to non-relational databases, indexed files, distributed database and abstract data types. Such advances result from the need for a standard way to access data.

Most large organizations have a mixture of hardware, such as micro-, mini- and mainframe computers that run various operating systems. The desire to have these components run the same software and share data fuels the demand for standards in operating systems, languages, databases and windowing systems. Such standards will translate into tools that programmers can use to build complex portable applications.

SQL is an example of what will happen in other tool areas. It has become the industry standard, providing a common language to access relational databases as well as portability for both applications and data. —*Scott Kitayama is UNIX product manager at Relational Technology in Alameda, California.*

ARTICLE INTEREST QUOTIENT
Circle On Reader Card
High 505 Medium 506 Low 507

MANAGEMENT DEMANDS PERFORMANCE...

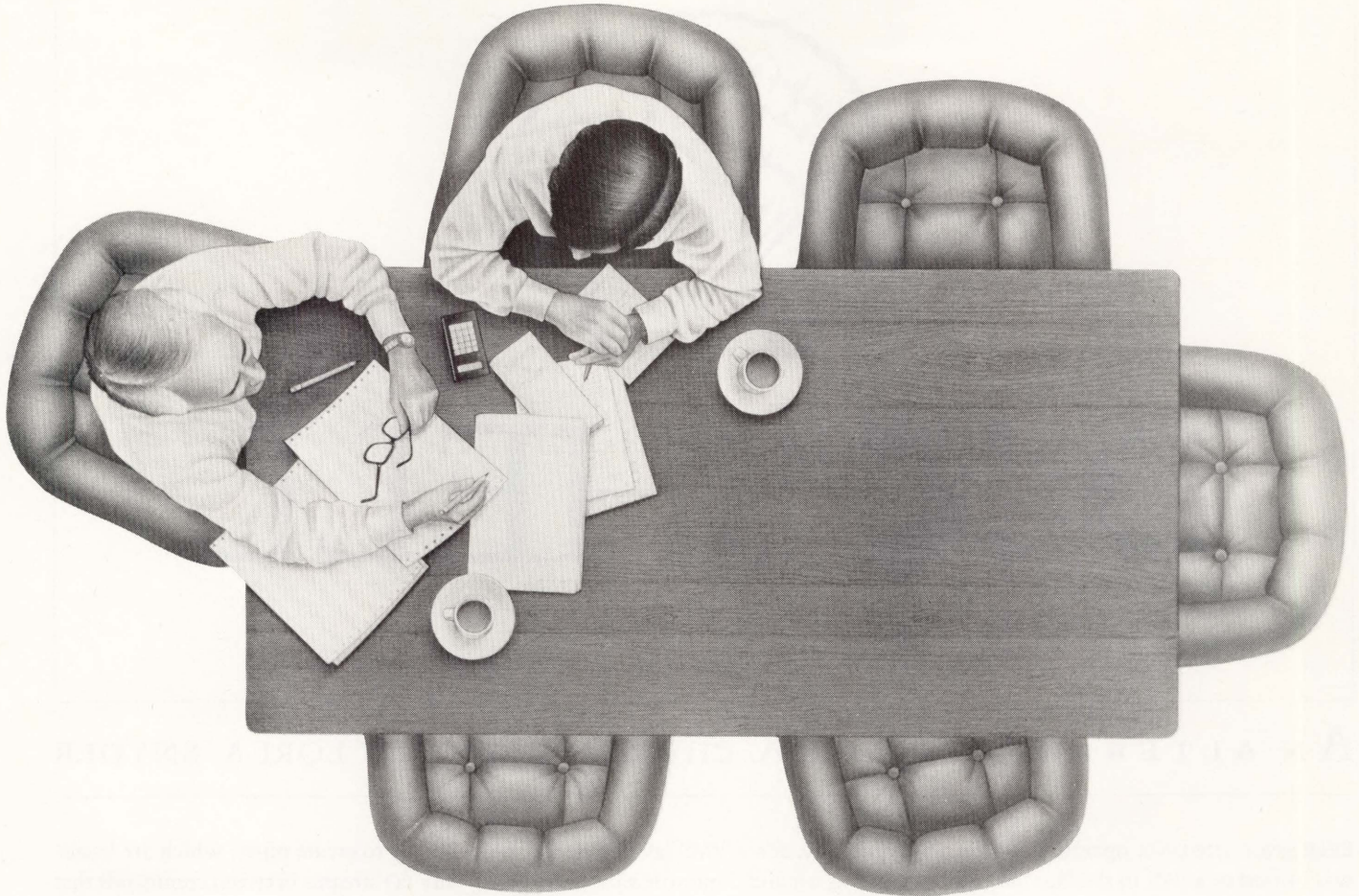

Conversionware™ BREEDS EXCELLENCE.

In management, excellence means delivering on time because business won't wait.

You must anticipate problems and have the best solutions ready. What happens when you discover your trusted software applications won't migrate to your new hardware or fit your new development environment? If you spend critical time and resources rewriting them, how will your performance be judged?

*The real question is:
"Will you be prepared to deliver excellence?"*

Your answer is "Yes" with Conversionware language translation solutions from Rapitech.

With Conversionware you'll preserve your most critical assets, the software that is the backbone of your organization.

That's excellence!

Fortran to Ada
FORTRIX®—Ada

Fortran to C
FORTRIX®—C

Cobol to C
COBLIX™—C

VMS to F-77
FORTRIX®—VMS®



MONTEBELLO CORPORATE PARK
SUFFERN, NY 10901
914-368-3000

Make the decision that IBM,® Boeing, Ford, AT&T,® Lockheed, Honeywell, Los Alamos and over 100 other companies have made. Call or return this coupon for more information today!

I'm interested in:

FORTRIX—Ada
 COBLIX—C

FORTRIX—C
 FORTRIX—VMS

Name _____

Company _____

Address _____

City _____

State/Zip _____

Phone _____

CIRCLE 297 ON READER CARD

FORTRIX, COBLIX & Conversionware are trademarks of Rapitech Systems, Inc. / VMS is a registered trademark of Digital Equipment Corporation. IBM, PC/AT & PS/2 are registered trademarks of International Business Machines Corporation / AT&T is a registered trademark of American Telephone & Telegraph.

800-FORTRIX 800-COBLIX
FAX: 914-368-3082
TELEX: 509210

**NOW AVAILABLE ON
PC/AT & PS/2**



DEC/SHELL

AN ALTERNATIVE UNIX environment. BY LORI A. SNYDER

EVER SINCE THE UNIX operating system was ported to a VAX in the late '70s, the UNIX-VAX combination has been popular among UNIX fans. Unfortunately, for some of those fans, circumstances often dictate that a VAX run VMS, DEC's own proprietary operating system. DEC/SHELL provides an alternative to those UNIX devotees by emulating a UNIX-like environment under VMS.

DEC/SHELL essentially is a command line interpreter that provides a user interface like the Bourne Shell of UNIX version 7. It consists of more than 60 of the most common UNIX commands and utilities (see Table). Like the Bourne Shell, DEC/SHELL provides the Shell programming language, including structured constructs (e.g., While, If-Then, Case and For), I/O redirection, pipes and string substitution.

DEC/SHELL runs under the VMS operating system. In DEC's ter-

minology, it's a VMS layered product. Sold as a standalone software package, it requires the presence of the VAX C language and its Run-time Library on the host VAX. Each DEC/SHELL command invokes a standard VMS image that executes similarly to images invoked by Digital Command Language (DCL), the VMS command line interpreter.

As you might expect, DEC/SHELL commands execute slower than the same commands issued on a native-mode UNIX system (e.g., DEC's ULTRIX-32). Accordingly, DEC/SHELL was described by one reviewer as "competent but sluggish." On a more positive note, however, DEC/SHELL only requires about 2,000 disk blocks, an amount of space that wouldn't be missed on most systems.

Advantages

DEC/SHELL offers some distinct advantages over DCL. The UNIX Shell has the

ability to create pipes, which are basically I/O streams between commands that allow the output of the first command to become the input to the next. DCL doesn't have such a capability.

Pipes allow you to create single line commands whose functions resemble that of entire programs. For example, a DCL user probably would have to write an entire program to implement the following command, which sorts a phone list, removes any numeric fields, puts the header Distribution on the printout and sends the list to the line printer:

```
sort +1 -2 phonelist | tr -d 0-9 | pr
-h Distribution | lpr
```

There are also several useful utilities that DCL doesn't offer. Some of these are **uniq**, which only writes the unique lines in a text file to the standard output; **grep**, a sophisticated search utility;

Clearly A New Concept

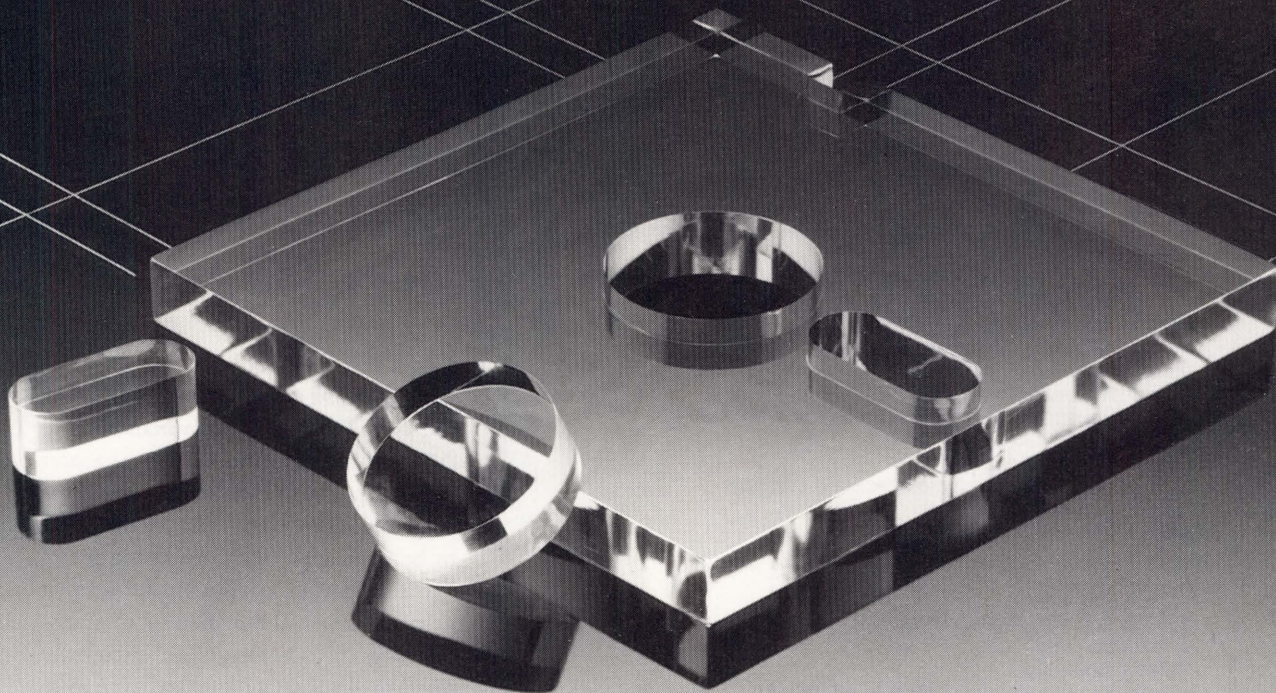

DEC™ Software Emulation for non-DEC systems

Off-load ALL-IN-1 from your VAX.

Desk Executive is designed to work as a PC partner with ALL-IN-1 to emulate ALL-IN-1 on your PC, distribute your ALL-IN-1 computational load, and support all user PC applications. \$495 per PC.

Simulate DCL on non-DEC systems.

VCL is a Digital Command Language software emulation that allows you to continue using powerful VMS commands, VMS mail, logic flow, symbols, and on-line help as you move to MS-DOS and UNIX environments. \$195 per PC.

Take EDT text editing with you.

EDT+, now 30% faster than our popular PC/EDT software, emulates all the features of VAX EDT including every gold key function in the exact EDT layout, VAX communications during editing, journal files, nokeypad



and line modes, and much more. For MS-DOS and UNIX environments. \$295 per PC.

Popular PC and UNIX environments.

Our DEC software emulations are supported on IBM PC's, Compatibles, SUN, ALLIANT, ELXSI, CONVEX, GOULD, HEWLETT-PACKARD, and many others.

Clearly a winning concept.

Our DEC software emulation of EDT is running in over 10,000 multi-vendor VAX sites around the world. Make your non-DEC life easier. Call or write us for more technical information about DEC software emulations.

DEC, VAX, VMS, ALL-IN-1 are trademarks of Digital Equipment Corporation. UNIX is a trademark of AT&T. MS-DOS is a trademark of Microsoft. IBM is a trademark of International Business Machines, Inc. PC/EDT, EDT+, VCL, Desk Executive are trademarks of Boston Business Computing, Ltd.

BOSTON BUSINESS COMPUTING, LTD.

The DEC™ Compatible Software Company

Riverwalk Center • 360 Merrimack Street • Lawrence, MA 01843 • (617) 683-7920

CIRCLE 290 ON READER CARD

Table.

Utility	Function
alias	Enables environment variables to be used as command synonyms
awk	A pattern matching language
basename	Removes file name affixes
cal	Displays a calendar
cat	Concatenate and display files
cd	Change working directory
chmod	Change mode of file; i.e., protection bits
chown	Change owner or group of file
cmp	Compare two files
cp	Copy file(s)
date	Display or set the system date and time
dc	Desk calculator
dcc	Maps applicable ULTRIX cc command line switches into VAX C and VAX Linker commands
dcl	Invokes the Digital Command Language (DCL) commands parser or creates a DCL subprocess
diff	Differential file comparator
diff3	Three-way differential file comparison
echo	Echo arguments
ed	Standard UNIX text editor
eval	Expands all command line arguments and executes the result as a command
exec	Executes a command and exits
export	Passes environment variables to programs and subshells
expr	Evaluates an expression
false	Returns a failure status value
find	Find files
grep	Search file for pattern
head	Print first part of file
join	Joins files according to specified relations
kill	Terminate a process
lex	A lexical analysis tool
login	Connects user's terminal to a system on the network
logout	Terminates an interactive terminal session
ls	List contents of directory
m4	Process macros for C and COBOL
mcr	Invokes the Monitor Console Routine (MCR) command parser or creates an MCR subprocess
mkdir	Create a directory
mv	Renames files and directories
nroff	Text processing package for formatting text files, which also includes neqn, deroff, tbl, col, colcrt, collpr and the ms and me macro packages
od	File dump
pr	Format and print file
ps	Process status
pwd	Print working directory name
read	Assigns the values of the next line read to the specified variable
readonly	Prevents existing environment variables from being reassigned
rm	Remove or delete files
rmdir	Remove a directory
sed	Stream editor
set	Sets shell flags or displays current environment variables
sh	Execute shell command script
sleep	Suspend execution for interval
sort	Sort or merge files
tail	Print last part of file
tar	Tape archiver
tee	Pipe fitting
termcap	An ASCII terminal database and associated routines that allow low-level terminal operations to be performed from an application
test	Condition checker
touch	Update last modified date of file

Continued.

Courtesy of Digital Equipment Corporation.

VAX DEC/SHELL utilities.

and **wc**, which counts the number of words, lines and characters in a text file. Fortunately, for the DCL user, many of the DEC/SHELL commands can be run under DCL, if they're defined to be foreign commands.

Conversely, DEC/SHELL users can elect to use DCL commands. Preceding

DEC/SHELL isn't intended for users who want full-blown UNIX.

a command with **dcl** causes DEC/SHELL to pass the rest of the command line to DCL for interpretation. Also, the user can type **set-d**, which causes any future command not recognized by DEC/SHELL to be passed to DCL for execution.

DEC/SHELL contains routines that help minimize the difficulty of transporting a C language program developed on a UNIX-based system to the VMS operating system. These routines enable the programmer to use UNIX filename syntax under VMS and gain access to system and process information in a more UNIX-like manner.

Finally, DEC/SHELL is a fully supported, fully integrated DEC product. New versions of DEC/SHELL are released at the same time as VMS updates. Software maintenance, which includes periodic updates and access to DEC support systems, can be purchased at a reasonable rate.

Target Market

DEC/SHELL is intended for use by UNIX fans who are forced, for whatever reasons, to work on a VAX running VMS. According to DEC, most DEC/SHELL customers fall into several categories. First are those users who only know UNIX but eventually will have to learn VMS. In this sense, DEC/SHELL is a valuable migration tool,

FROM MICOM INTERLAN: MORE BRIDGE FOR THE BUCK.

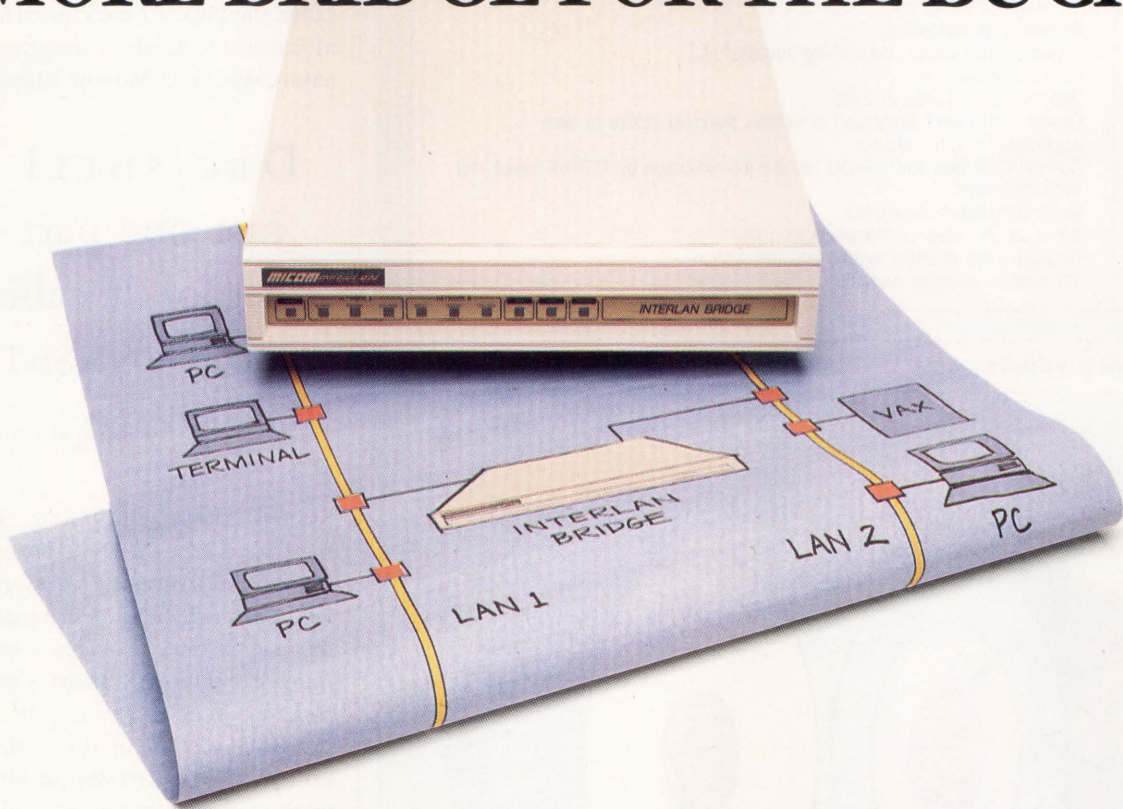

THE POWER OF THE DEC LANBRIDGE 100 FOR HALF THE PRICE.

Here's good news for anyone who's ever needed a DEC LANBRIDGE 100, but hesitated to plunk down eleven grand for it.

Now you don't have to.

Introducing MICOM INTERLAN's IB3000 Data Link Bridge. It's everything you've always wanted in a network bridge. All the performance and features of DEC's LANBRIDGE 100—for just \$5495.

Make the most of your network—and your budget.

The IB3000 is actually more than just a bridge. It's a whole family of bridge products, all distinguished by high performance, interactive network management, and IEEE 802.1 support. From a fully upgradable starter product to the top-of-the-line IB3000, with an aggregate listening rate of 28,000 packets per second, the IB3000

family combines advanced design with exceptional price/performance.

MICOM INTERLAN. Better bridges for the buck. Better choices for your network.

The IB3000 Bridge family is the latest in a long line of MICOM INTERLAN products combining innovative hardware architecture with advanced network management software. Whether you're looking for a better bridge, or simply a better deal, we're the people to talk to *before* you make your choice.

To order or obtain more information, call MICOM INTERLAN today at 1-800-LAN-TALK (in Massachusetts, 1-800-TELL-LAN).

DEC and LANBRIDGE 100 are trademarks of Digital Equipment Corporation.

MICOM INTERLAN Division, 155 Swanson Road, Boxborough, Massachusetts 01719

MICOM INTERLAN

CIRCLE 140 ON READER CARD

Table... *continued*

Utility	Function
tr	Transliterates characters
true	Provides truth values; do nothing successfully
tty	Print terminal name
uniq	Report repeated lines in a file
units	Converts quantities expressed in various standard scales to their equivalents in other scales
uucp	Copies ASCII files and initiates remote job execution on ULTRIX-based and VMS machines
wait	Await completion of process
wc	Count words, lines or characters in a file
who	Displays a list of users logged into the system
yacc	Yet another compiler compiler

Courtesy of Digital Equipment Corporation.

VAX DEC/SHELL utilities.

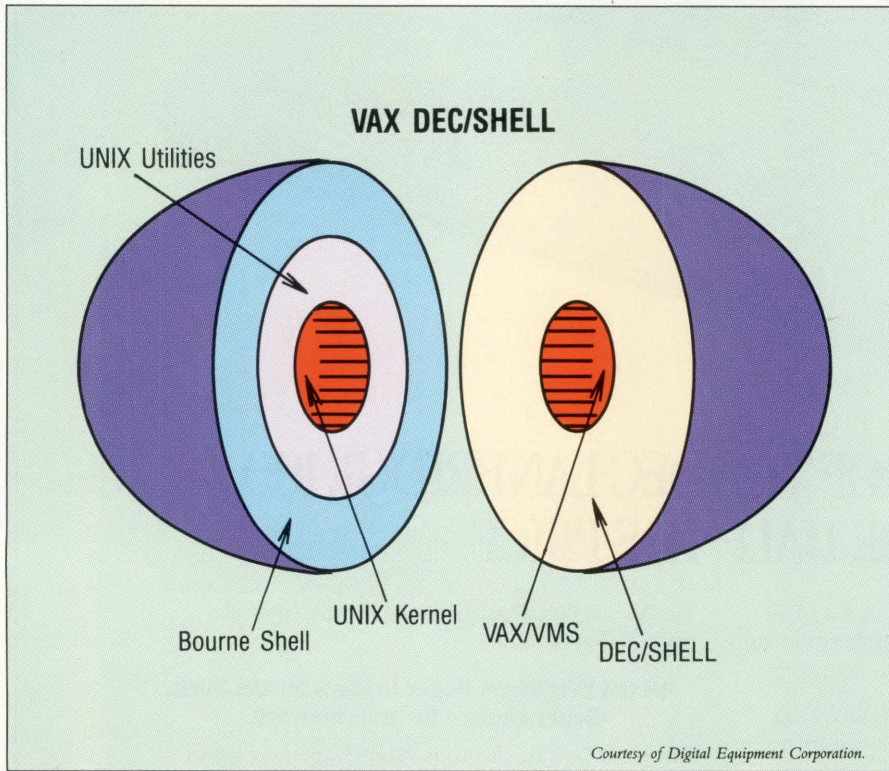

Courtesy of Digital Equipment Corporation.

DEC/SHELL provides a familiar environment on VMS to the UNIX user.

for it enables them to be productive immediately.

DEC/SHELL also provides a means by which UNIX and VMS users can exchange information; in particular, UNIX tapes can be read under VMS by using the DEC/SHELL **tar** utility. DEC calls DEC/SHELL a coexistence tool.

Users who know both UNIX and

VMS and want to use both, find DEC/SHELL attractive, as it enables them to selectively use features of either operating system.

DEC/SHELL isn't intended for users who want full-blown UNIX. Not a complete implementation of UNIX, it's not intended to replace UNIX. DEC/SHELL doesn't include the UNIX

backup utilities **dump** and **restore**, for instance, as the VMS backup utilities can serve those functions.

Other Pieces Of The Puzzle

DEC/SHELL is just one part of a toolkit called the VNXSET package, which also includes DEC Code Management System (CMS), DEC Module Management

DEC/SHELL IS just one part of a toolkit called the VNXSET package . . .

System (MMS) and VAX C. Together these tools create a UNIX-like development environment under VMS. DEC/CMS, a file management and maintenance system, provides a capability much like the UNIX Source Code Control System (SCCS) utility. DEC/MMS is the VMS version of the UNIX **make** utility, which provides an automated method of updating source code if constituent modules are changed. Finally, VAX C provides the C programming language that's a standard part of every UNIX system.

DEC/SHELL IS A VALUABLE tool for increasing the productivity of a VMS-based organization that consists of some UNIX users. It can eliminate the frustration of UNIX users who don't know VMS and have to be productive immediately. Also, DEC/SHELL increases the productivity of an organization that contains both VMS-based and UNIX-based systems by facilitating information exchange between those systems. DEC/SHELL can increase the flexibility of the DCL user by making UNIX commands available to them.

ARTICLE INTEREST QUOTIENT
Enter On Reader Card
High 555 Medium 556 Low 557

"I'll call you right back."

"The check's in the mail."

"It debugs in C like ECHO."

Promises, Promises.

Everybody promises, but nobody delivers a real-time, emulator-based C-debug environment like Arium's ECHO. 16-bit, true multitasking and UNIX®-based, ECHO gives you more power, speed and menu-driven features to handle the 68000 and other μ Ps better than the HP 64000, or anything else.

Just words, you say, promises like all the rest?

Prove it to yourself. Read the screens below. Then ask any other development system—standalone or host control—to match them. We'll wait.

Now you know a few reasons (and there are plenty more) why ECHO should be your emulation tool for today's increasingly complicated software debugging.

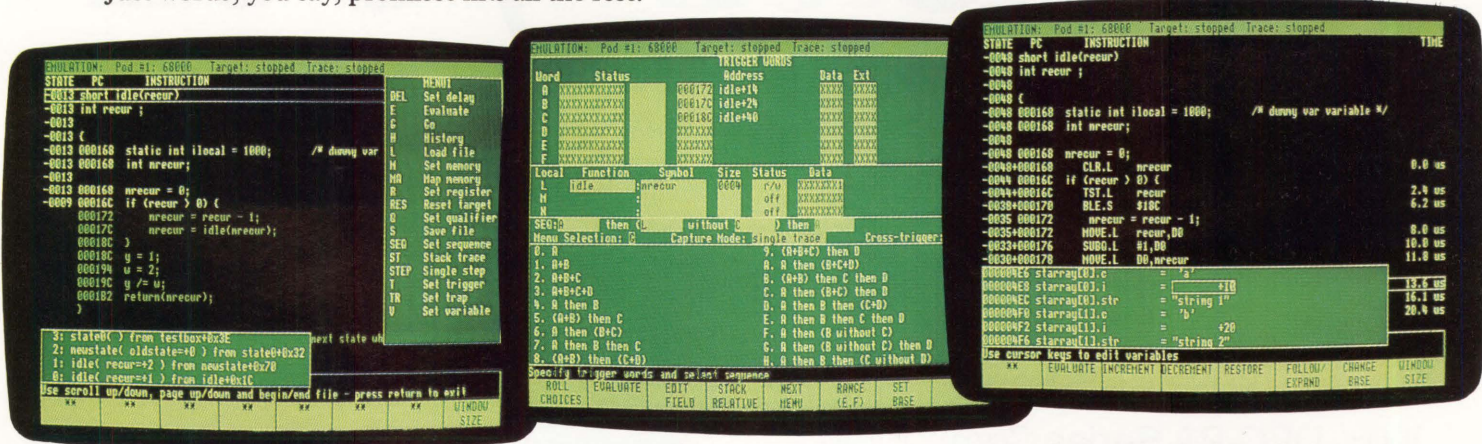

Code Preview™ lets you see where your code is going. You can follow calls and branches (to 99 levels) on the screen, to select the source line on which to trigger, then set and break in one keystroke! The highlighted trace display (in source) and stack trace window show the path your program took.

Stack-Relative Trigger lets you trigger on the addresses and values of stack-relative variables—a "must" for effective C-debug where the address of an automatic variable is different each time the function is called and is determined at execution. Here, a read of the local variable "nrecur" is included in the trigger sequence.

TimeStamp™ and variable display are two further features that are a must for real-time C-debug. Note the display of two instances of a structure in array "starray." The contents of these structures, as for any C variable, can be changed right on the screen.



For a demonstration call
800/862-7486 (CA 714/978-9531)



1931 Wright Circle, Anaheim, CA 92806
CIRCLE 215 ON READER CARD

UNIX is a registered trademark of AT&T.

Introducing a new line of disk drives that hits them all. The new DS-Series from Century Data, with storage capacities from 450 MB to more than 1 GB. If compatibility is what you respond to, you'll feel comfortable knowing the new DS-Series drives are the first DEC® plug compatible replacement drives for the RA81 and 82 Series that don't require extra cabling or external boxes. If size is the big issue with you, look at how our drives measure up to theirs. Ours are half the size, and half the weight, twice the storage capacity now. Looking for low power less than 1/3 the power of a

Compatibility

Size

Power

which makes it very easy to fit in the same rack you're using consumption? Our drives draw DEC unit at start-up, and use

What's your

The New DS-Series
100% DEC-RA Series Compatible.



just 1/2 the power to run. They can save enough in power costs to pay for themselves in less than 4 years. Does speed catch your attention? The DS-Series boosts system performance with average seek times of just 15 to 18 milliseconds. Or do you look at the bottom line first? Good, because the new DS-Series drives will cost you less there. Which is pretty impressive when you consider they give you so much more. And if you're the type to put an emphasis on reliability, you should know we've been building extraordinarily reliable disk drives for more than 20 years. For more information on the new disk drives that push all the right buttons, call us or write Century Data Incorporated.

Speed

Cost

Reliability

hot button?



CENTURY DATA

2055 Gateway Place, San Jose, CA 95110.
Outside California call 1-800-325-5756.
Inside California call (408) 298-5756.

CIRCLE 279 ON READER CARD

MAGEN-ATION

By David B. Miller

Imagen Corporation's ImageServer XP Series Printers Combine Flexibility, Compatibility, Functionality And Speed In One Package.

Although desktop publishing and low-cost desktop laser printers have stolen the show in recent months, large laser printers, capable of high speeds and sophisticated abilities, are needed to tackle big printing jobs.

A recent entry into the high-end laser market is the ImageServer XP Series printers from Imagen Corporation. The entire line takes advantage of Canon's latest laser print engine, the LBP-SX, and is designed to handle larger, more complex printing tasks. Network ready, they're flexible units. A number of printer emulations are possible, and Adobe's PostScript compatibility is available.

Our test model 6320 boasted the following features:

1. The LBP-SX is capable of providing 300-dpi resolution, quiet printing (less than 57dB), a 35,000- to 45,000-page-per-month duty cycle and can handle various paper sizes and types.

2. Real-time rasterization, a feature that allows large numbers of pages to be held in memory, provides higher page throughput.

3. Print speeds of 20 ppm for our model 6320.

4. A separate image processor containing three 68000 series microprocessors, 5 MB of RAM, 2.5-MB bitmap memory, single floppy and a 20-MB Winchester hard disk drive.

5. An RS-232C port to connect a console terminal.

6. A number of host interface and protocol options, including Ethernet (TCP/IP), RS-423 (XON/XOFF, sequence packet, IBM 2780/3780), Versatec, Dataproducts and Centronics (standard ASCII or binary).

7. Emulations of the Diablo 630, Epson FX+, IBM 5152, Tektronix 4014 graphics terminal and IBM 1403 line printer. A bit array emulator also is included. Emulations may be mixed on the same page.

8. Single- and dual-sided printing, page reversal and multiple copy printing.

9. Three input paper trays, holding 2,500 sheets and two output trays, holding 1,700 pages maximum.

10. UltraScript, Imagen's PostScript-compatible interpreter, is installed automatically when the printer is configured. Imagen's own IMPRESS and DDL languages also are supported, making the XP line multilingual.

The 6320 is 64 inches wide, 26 inches deep, 56 inches high and weighs 431 pounds unloaded. Power requirements aren't unusual; any common grounded outlet will do. You also will need to find some space for the image processor, which is roughly the size of a full-sized PC/AT (without monitor) and for a video terminal, if you decide to dedicate one solely to the printer.

Daily operations, such as changing toner and paper, are easy to do. Everything is accessible up front. Clearing paper in the event of a jam is also simple, although it wasn't required often. The user manual is clear and has lots of good figures and diagrams.

Speaking TCP/IP And Other Prerequisites

The 6320 isn't your typical plug-it-in-and-print machine. A number of configuration steps must be carried out and perhaps tried to get the proper setup for your site. Installation



MEMORIES YOU WILL NEVER FORGET!!

Available Soon

MEMORY FOR THE IBM PERSONAL SYSTEM/2 MODEL 50/60

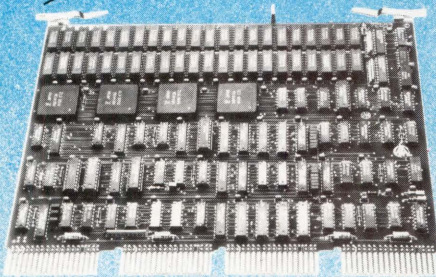

CI-PMI-EDC

- Full PMI support
- Single bit error correction, double bit error detection
- Runs complete DEC diagnostics
- 4 megabytes on one board
- Control Status Register (CSR)
- Block mode DMA

Visit us at
DEXPO* West 87
Disneyland Hotel
Anaheim, CA
December 8-10, 1987
Booth #358

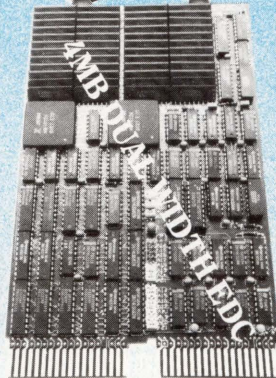

CI-QBUS-EDC LSI-11, J-11, MICROVAX I

- Single bit error correction, double bit error detection
- Runs complete DEC diagnostics
- Dual width card
- 2 or 4 megabytes on one board
- Block Mode DMA

Additional Qbus Memories

- CI-1173: 4 megabyte block-mode
- CI-1173-EDC: 2 megabyte error detecting and correcting w/block-mode
- CI-1123+: 1 megabyte dual width

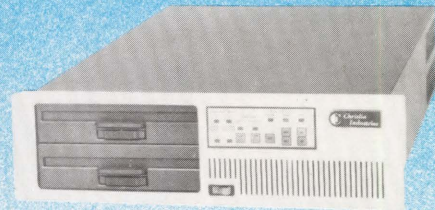

CI-MICRO-11 QBUS SYSTEMS

- LSI-11/23 or 11/73 CPU
- 256KB-4MB memory, 20MB-150MB Winchester, 5¼" or 8" dual floppy, or cart. tape, serial ports, 4x8 backplane, power supply all in a rack/table-top chassis.

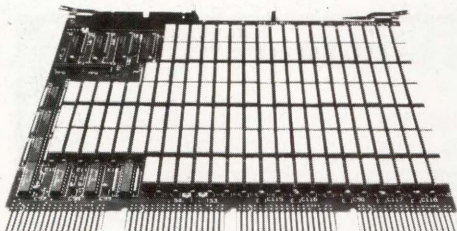

CI-MIV16

- 4, 8 and 16 megabytes on one board
- On-board parity
- Plug compatible to any MicroVAX II
- Completely hardware and software compatible with the MicroVAX II

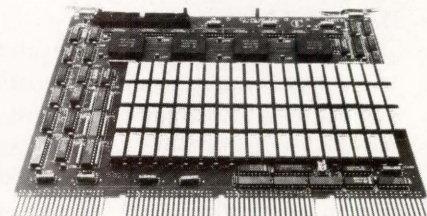

CI-MIV8-EDC

- Single bit error correction, double bit error detection
- 8 megabytes on one board
- MicroVAX II hardware and software compatible
- Control Status Register (CSR)
- MicroVAX error logger support

**CHRISLIN ALSO CARRIES STATE-OF-THE-ART MEMORIES
FOR VAX, VMEbus, MULTIBUS, IBM PC or RT**



Chrislin Industries Caribe, Inc.

Call Toll Free: **800-468-0736** (est.)

P.O. BOX 1657 SAN JUAN, PR 00629
TELE. 809-876-5205 TELEX 345-4170 (CHRISLN PD)

CIRCLE 104 ON READER CARD

31332 VIA COLINAS, WESTLAKE VILLAGE, CA 91362
TELE. 818-991-2254

FAX NO. (809) 876-6140

REPRESENTATIVES: CANADA—TECH-TREK, ONTARIO (416) 238-0366 MONTREAL—(514) 337-7540
WEST GERMANY—DEMA COMPUTERTECHNIK (089) 272-3240 SWITZERLAND—DAP (01) 948-0580

PMI, PDP, QBUS, LSI-11, J-11, MicroVAX, VAX are trademarks of Digital Equipment Corporation. IBM is a trademark of International Business Machines. MULTIBUS is a trademark of Intel Corporation, IBM Personal System/2 is a trademark of International Business Machines.

The 6320 occupies the space of a copier. The terminal (not included) makes job control and configuration changes easy.



involves physically interfacing the printer to the host, configuring the image processor and installing on your VAX the IMPRINT command software, written by Kellerman and Smith of Portland, Oregon.

The first step, interfacing the printer to the host, simply requires a serial or parallel hookup, or you can choose, as we did, to hang your 6320 off your Ethernet as a node. Before using the printer, we installed TCP/IP software and the network hardware on which it runs. Imagen printers support both the Excelan and Wollongong Group network boards. We chose the Excelan board and EXOS TCP/IP protocol software for our site, installing the board in our MICROVAX II.

After the network equipment and software were installed and running (for us, no other devices used this protocol on the cluster), the next task was to configure the 68000 microprocessor-based image processor, which is a separate unit placed either on top or on the side of the printer.

Configuring the image processor

takes time, but the process is straightforward. It involves connecting a terminal to the processor's built-in RS-232 serial

port, initializing the internal 20-MB hard drive and copying the X320 system software and printer fonts onto it, using the supplied Disk Management software. Next, specify the appropriate parameters, chosen from the configuration menu (see Screen 1) by running the configurator, supplied on floppy disk.

Select the appropriate communications parameters, the type of print engine you're using, paper bin information, any system-wide default document control information and the desired UltraScript settings. If you can spare the terminal and leave it with the printer, the process of changing these settings later will be easier.

The initial image processor installation took 45 minutes; 90 percent of that time was used for copying the contents of the various disks (four system disks containing system software and the basic core-type fonts and eight more disks containing other font styles) to the hard drive. Changing settings later presented no hardships.

Also, you can get online system in-

The Configurator will display this menu of options:

Choose option:	to
spp:	select serial sequenced packet communications
serial:	select serial byte stream communications
cent:	select parallel byte stream communications (Centronics)
datap:	select parallel byte stream communications (Dataproducts)
vers:	select parallel byte stream communications (Versatec)
bsc:	select 2780/3780 binary synchronous communications
tcp:	select Ethernet TCP/IP communications
speed:	select console speed
X308:	select print engine type
X320:	select print engine type
doc:	select system-level document control information
test:	select test file printing at startup
ultra:	select UltraScript configuration
exit:	exit, updating configuration
reset:	reset all configuration information to default values
abandon:	exit, abandoning all configuration changes
help:	run through the configurator instructions

Screen 1: The image processor's configuration menu allows you to specify default communications, document control and UltraScript settings.

Now on Both VMS™ and Ultrix™: The VAX™ Office System for the Highest Common Denominator.

Alis®. Designed for the professional office.

The only integrated VAX office system with the architecture and capabilities to satisfy the demanding professional user. Alis has all the benefits of communications-based office automation systems. And combines them with the advantages of graphics-based personal computer applications and the presentation quality output of desktop publishing systems. Multi-window Alis networks workstations, PCs, and terminal-based multi-user systems company-wide, making full use of the graphics capabilities that each device offers.

Alis. The multi-vendor office system.

Alis' multi-vendor networking allows VMS and Ultrix VAXs and VAXstations, 68000-based workstations and MS-DOS PCs to be combined into one integrated office system.

To find out more, call John Butler, V.P. of Marketing,
at Applix (617) 870-0300.

Alis combines text, spreadsheets, graphics and database in single, always editable documents handles proportionally-spaced and multiple-size fonts WYSIWYG-style provides automatic formatting of reports, letters, memos, etc. sophisticated equation-solving spreadsheet drawing, scanned images and business graphics personal and office databases integrated electronic mail and meeting scheduling multiple windows supports graphic workstations, PCs and terminals.

Alis, and Applix are registered trademarks of Applix, Inc.
Ultrix, VMS, and VAX are trademarks of Digital Equipment Corporation.
MS-DOS is a trademark of Microsoft Corporation.

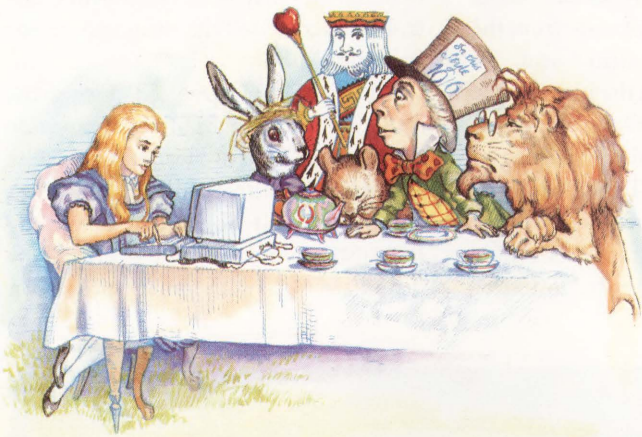

digital™

Cooperative
Marketing
Program

Alis®

from **APPLIX®**

The integrated software system for the professional office.

Finally, some answers in Wonderland.

APPLIX, INC., 112 TURNPIKE ROAD, WESTBORO, MASSACHUSETTS 01581 (617) 870-0300

CIRCLE 238 ON READER CARD

formation any time, if a terminal remains attached to the processor. A complete set of console commands is available to gain printer information, control jobs and manage the disk system.

The most cryptic part of the processor configuration was to derive the TCP/IP internet address. It was easier than we thought. Because we had no other devices running TCP/IP, we made the VAX address 1.1.1.1 and the printer 1.1.1.2. You have to obtain the Internet address of the nodes on your network first, then use one that doesn't exist on your network. Other than this step, we took all the TCP/IP defaults.

The final step involved putting up the IMPRINT software on the VAX end. IMPRINT works with VMS queue and print management to prepare files for printing on the XP series printers. Installing IMPRINT supplies the necessary

TCP/IP hooks to make printing possible. It also establishes a print queue and the IMPRINT command that's used in place of the VMS PRINT command.

Imagen-ation Running Wild

Using the XP line involves becoming familiar with its capabilities and how the IMPRINT software works with the image processor and VMS print services to format and interpret incoming files correctly.

The 6320's image processor obtains printing information, not only from the IMPRINT command line and its qualifiers, but also from the inclusion of an optional Document Control Header, which can be placed at the beginning of the file to be printed. This Document Control Header can contain some of the same information that the IMPRINT command qualifiers specify. IMPRINT

qualifiers (and Document Control Headers) can specify which printer you need to emulate, the number of desired copies, single or duplex printing, page orientation, type of forms and many other options.

A single job contains documents that can be printed with the same characteristics, and the IMPRINT command lists what all the needed settings do. Should you decide to print a mixture of documents in a single job, individual files may need Document Control Headers to tell the image processor to switch modes.

Defaults are specified during installation in the form of a system-wide Document Control Header. Generally, any print control information you specify in your document or via the IMPRINT command will override the defaults set up on the image processor.

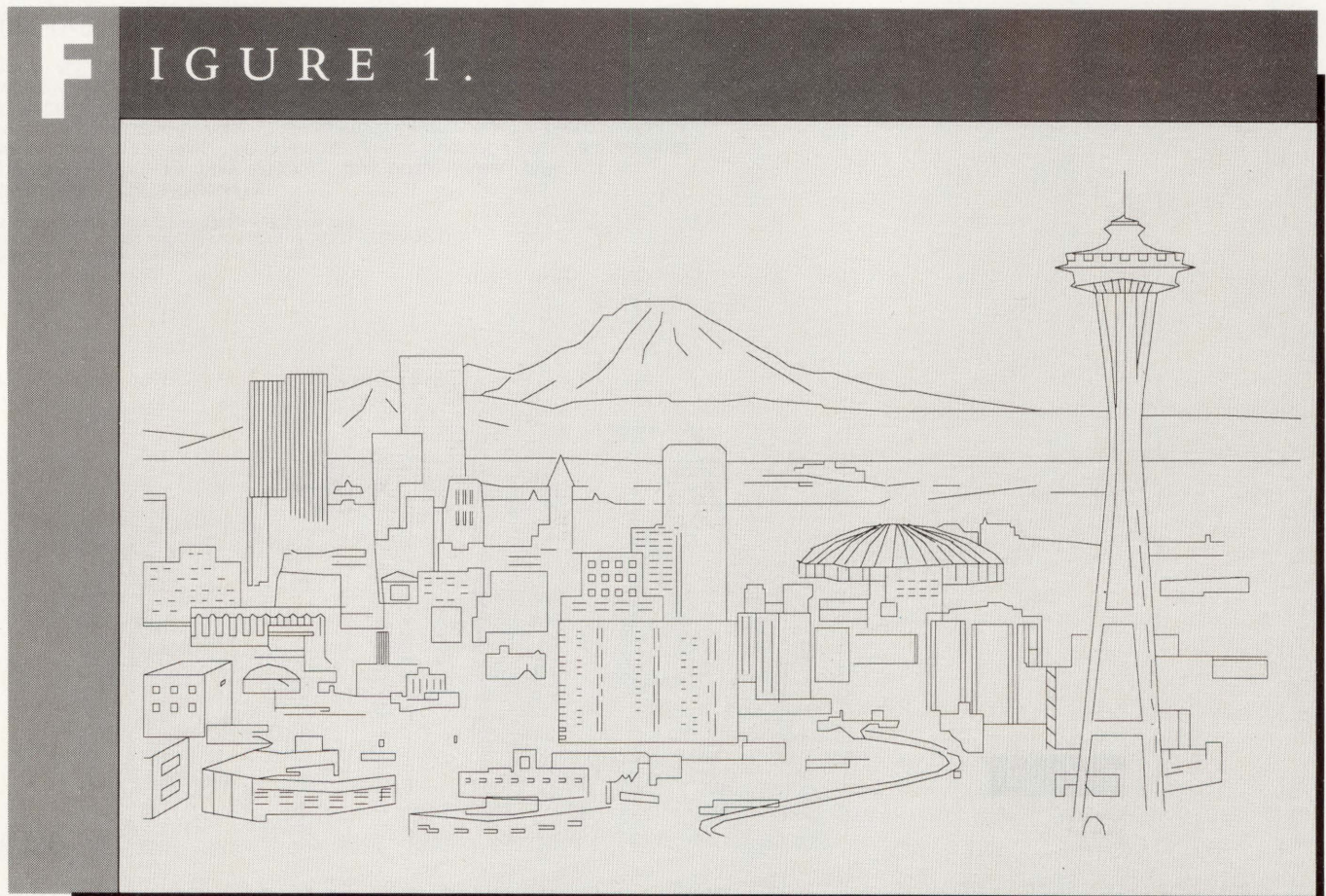

This Tektronix 4014 graphics terminal file took one minute to process and print.

F I G U R E 2 .

Every entity in the data dictionary is described in detail; some or all of the effort involved in doing that can be done while working in one of the other Excelexator areas such as graph creation. You may also list, modify, delete, copy and rename entities by directly accessing them in the database. For such operations as rename, you have the option of globally affecting other records in the database in which the renamed entity occurs. This eliminates the need to change each entity occurrence manually. Changes made in the Excelexator data dictionary will then also be reflected in any graphs, screens and reports that contain that piece of information. Conversely, making changes, for example, changing the name of a module in a data flow diagram, will automatically effect changes to all data dictionary records that contain that object, a real time saver.

Excelexator tracks all relationships between entities such as those entities that contain other entities, graph objects that explode to other objects, the relationship between a report definition and the screen data file used to input test data and others. Additionally, audit attributes are recorded for each entity that lists the date of last modification (who, when), who created this entity, how many changes have been made to this entity so far and any locking mechanism currently in force. The relationship tracking and audit features help eliminate the confusion that arises when more than one person works on a project simultaneously and provides a good security mechanism to monitor access.

Another powerful data dictionary capability lies in its reporting features. The Report Writer allows you to obtain sorted and formatted listings of all or selected data dictionary records based on criteria you specify. The report feature greatly helps you check the database for completeness and accuracy and will help you plug up any holes you may discover in your project.

XLD INTERFACE - Since you may find the need to share project data or to allow access by fellow analysts to portions of a project's data, Excelexator's XLDinterface is needed to give you the control needed to track all such movement of data to those individuals.

Excelexator's Export and Import facilities allow you and members of your design team to copy all or parts of the project's dictionary to other projects. In addition, a Locking feature can be enforced whereby specified data dictionary records can be protected from accidental update by multiple users. A preview feature is included so that you can view the data records to be modified before actually operating on them.

In an environment where VAXstations are linked via DECNET or in a cluster situation, project data can be shared among multiple nodes across the network. RMS's record locking facilities ensure that multiple users cannot modify the same record simultaneously. The VAXstation release notes indicated that multiple user access of project data has limited protection at this point, but it should be beefed up in future releases. While multiple users cannot modify the same record simultaneously, they can modify related records and dictionary entities. Therefore, it is recommended that procedures be established that monitor and review a project's data regularly to ensure its integrity. Additionally, graph data CAN be modified by multiple users at the same time, since their storage scheme is different than that of the dictionary's records, so you have to be very careful that project graphs are complete and correct regularly.

Three levels of access determine the degree to which you can alter project data. READ users can really only look at data and not much else. In other Excelexator areas such as Graphics and Screens, a READ user can only perform operations resulting in output.

LIMITED users have a little more leeway including the ability to modify some of the project's data. A LIMITED user can perform just about any action on any record in the project dictionary as long as it is not locked

by another user.

The MASTER user is usually the project or system manager. MASTER users have all privileges. For large projects with many smaller sub-projects, MASTER access rights are usually given to each sub-project manager for the particular project section on which they are working.

ANALYSIS - Excelexator's analysis section provides you with the tools necessary to scrutinize your project design and the elements comprising it.

Graph analysis allows you to check for such trouble signs as omissions, redundancies and graph inconsistencies. A level balancing feature checks for consistency between data flows on one explosion level and the data flows on subsequent levels. An explosion analysis list all explosion levels (up to nine levels below the top) allowing you to trace all the connections and paths to and from various processes and entities on various levels. Excelexator never automatically changes anything about the system, it merely reports potential trouble spots and suggests how you may eliminate them.

Data dictionary items may be grouped together into what Excelexator terms "entity lists." You have a lot of control over what dictionary items are included in a particular group. For example, you may wish to generate an entity list containing record descriptions only. Or, you may need a list of all procedures within certain modules. Being able to narrow down the list of required items allow you to zero in on particular groups rather than having to search through a long list of entities, most of which may not be directly related to those in which you are most interested. The Report Writer feature mentioned in the section on the XLDictionary can be used here to generate hardcopy reports of the entities you select. The entities you select may also be analyzed as a unit and exported to other projects, making it easy to scrutinize selected groups of project data items and to share it with others.

HOUSEKEEPING - To maintain Excelexator and the projects on your system, you may from time to time need to access the Housekeeping function. Such operations as adding, modifying and deleting projects, backing them up, adding, changing and deleting users for projects and defining printer characteristics must all be done in the Housekeeping section.

The amount of control each individual has to carry out any of the above operations is governed by his access status. System Managers have primary responsibility to maintain Excelexator's environment in regard to available devices, system dates and the users of the system. Project managers exercise control of the project on the system and can add, delete or modify projects and any associated project parameters. They may also assign users to projects, granting them the access privileges discussed above in the section on the XLD interface. Regular users have restricted access depending on what the Project manager assigns each one.

DOCUMENTATION - The bane of any programmer's and analyst's existence, the longest four letter word in computing, documentation is often put off until the end of the project's design and is often not given the attention it deserves. Let's face it, writing documentation is BORING; besides, you know how the system works and can explain it to anyone much better verbally than in written form.

Unfortunately, you may not always be around to provide that information. People do leave and get other jobs, get sick and take days off, go on vacation, even forget! Documentation, therefore, is an important and necessary part of any system and cannot be neglected.

Fortunately, Excelexator takes some of the pain out of producing documentation. First, you draw a Document Graph, a tree-like diagram which depicts the documentation's overall structure and contents, similar to drawing a structure chart. This graph can be analyzed for completeness and

Two-up landscape mode is one of the many print options available in IBM 1403 line printer mode.

The capability of being able to specify document control information within each document gives you great flexibility and control over the printed result. Diablo-encoded documents can be followed immediately by Tektronix terminal graphics files, which then can be followed by PostScript-compatible files, requiring no physical reconfiguration of the printer. Supply the correct command qualifiers on the IMPRINT command line or within the file's Document Control Header, and you're off and running. Figures 1 and 2 illustrate

two print samples; Figure 1 is a Tektronix 4014 graphics terminal file, and Figure 2 is a portion of a file printed in IBM 1403 line printer mode, two-up with landscape orientation.

Regarding speed, we found the 20-pages-per-minute claim was accurate; a 513-page straight text document printed in 25 minutes. Tektronix 4014 files of approximately 70 blocks required a little more than one minute to print.

To test PostScript compatibility, we tried output generated by Microsystems Engineering's MASS-11 and MASS-11 Draw as well as a few small, PostScript programs. A 25,000-byte PostScript pro-

ImageServer XP Series Printers

Imagen Corporation
2650 San Tomas Expressway
P.O. Box 58101
Santa Clara, CA 95052-8101
(408) 986-9400
Price: \$35,950.
CIRCLE 511 ON READER CARD

gram required one minute to process and print. Initially, we had some difficulty with Postscript files not producing output unless /language = transparent was specified on the IMPRINT command

Network DEC to UNIX?

What You Didn't Know--Will Help You!

TCP/IP Networking Software...

Did you know that most UNIX computers already support industry-standard TCP/IP networking protocols? And that Process Software Corporation gives you TCP/IP networking solutions for more DEC operating systems than anybody?

For VMS, RSX, RT-11, IAS, And TSX-Plus...

Network to UNIX using just our TCP/IP software and your standard DEC Ethernet hardware on the UNIBUS, Q-bus, VAXBI, or the new MicroVAX 2000. And run concurrently with DECnet, LAT, or LAVC.

Designed To Benefit You...

Say goodbye to special hardware, messy installation, and unneeded layers of software. Our TCP/IP products are modular, efficient, and designed for the operating system they run on. You benefit from ease of use, simple installation and virtually no maintenance.

For Every Application...

And we support the full range of popular TCP/IP applications, including FTP (File Transfer), TELNET (Virtual Terminal), TCP, IP, and UDP programming interfaces, and others.

You won't find a better lower-cost way to connect DEC to UNIX anywhere!

Interested? Call Process Software Corporation today.

PROCESS SOFTWARE 413-549-6994

35 Montague Road • PO Box 746 • Amherst, Massachusetts 01004

DEC, IAS, RSX, RT-11, UNIBUS, VAX, and VMS are Digital Equipment Corporation trademarks. Unix is an AT&T trademark. Ethernet is a Xerox Corporation trademark. TSX-Plus is a S&H Computers trademark.

CIRCLE 153 ON READER CARD

Excelan Inc.
2180 Fortune Dr.
San Jose, CA 95131
(408) 434-2300

CIRCLE 528 ON READER CARD

Microsystems Engineering Inc.
2400 W. Hassell Road
Suite 400
Hoffman Estates, IL 60195
(312) 882-0111

CIRCLE 461 ON READER CARD

Wollongong Group Inc.
1129 San Antonio Rd.
P.O. Box 51860
Palo Alto, CA 94303
(415) 962-7100

CIRCLE 529 ON READER CARD

line, but a new version of IMPRINT (2.0a) solved the problem.

Documentation is extensive. Included are an *Owner's Manual*, *Programmer's Guide*, *TCP/IP Guide*, IMPRINT command documentation, a manual for using the Image Processor and a quick reference guide.

Although the documentation is clear, it's not intended for novices. Inexperienced users probably will need additional assistance to become productive, as they may spend too much time reading about commands and qualifiers they'll never use.

THE IMAGEN 6320 IS fast, flexible and powerful. Its high throughput rate and features, such as dual-sided printing and whole document processing, will make large jobs easier to handle. The wide range of printer emulations that can be invoked on a document-by-document basis will appeal to sites with a variety of printing needs. The addition of UltraScript brings Imagen in line with industry-standard PostScript without sacrificing functionality in other areas.

The 6320 will allow you to use your Imagen-ation to its fullest extent.

ARTICLE INTEREST QUOTIENT
Circle On Reader Card
High 508 Medium 509 Low 510

Attention
Oracle Users!

Report writing just got easier.

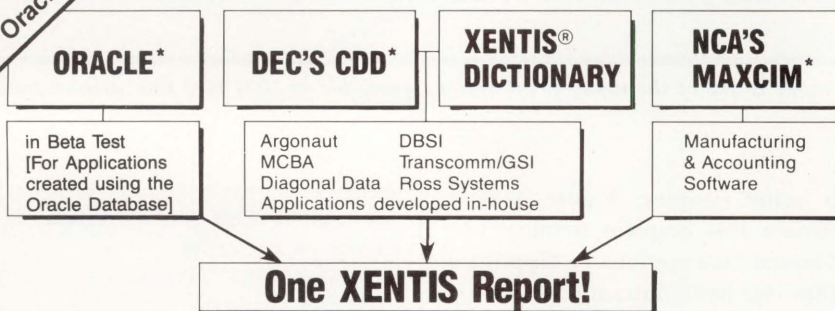

XENTIS—the premier report generator for DEC VAX/VMS computers—will soon be able to interface with the Oracle 4th GL. For programmers and nonprogrammers alike, XENTIS is fast and easy to use.

Proven in more than 500 installations, the Park Software report writer can combine information across several data bases. . . for example, your accounting staff can pull information from Ross Systems accounting software and combine it with data from Argonaut's Human Resources package in one report. And soon you'll be able to add data from applications created with the Oracle system.

To learn more about XENTIS and our fully functional evaluation kit, call (206) 343-0447 today!

CIRCLE 145 ON READER CARD



PARK SOFTWARE, INC.

P.O. Box 31529
Seattle, WA 98103-1529 (206) 343-0447

*Oracle is a registered trademark of the Oracle Corp. DEC and CDD are registered trademarks of Digital Equipment Corp. XENTIS and XENTIS/Dictionary are registered trademarks of Park Software, Inc. MAXCIM is a registered trademark of the NCA Corp. MCBA is a registered trademark of MCBA, Inc.

Isn't it time you settled for less?

**Less production
cost.
Less downtime.
Less maintenance.
Less space.
Less noise.**

If you're looking for a hassle-free printer that's less expensive to buy and downright frugal to operate, look into Hitachi Koki. You'll find exceptional reliability with no preventive maintenance requirements. Consistent OCR print quality. Plug compatibility with virtually any system. And the quietest, most compact cabinets in the business.

Why pay more? Tens of thousands of Hitachi Koki band printers have proven themselves in offices and data centers just like yours.

For details and the name of your local distributor, contact Nissei Sangyo America, Ltd., 800 South Street, Waltham, MA 02154, (617) 893-5700. Or call our west coast office at (619) 485-8552.

Hitachi Koki band printers

CIRCLE 300 ON READER CARD



700 and 1,000 LPM

1,500 and 2,000 LPM

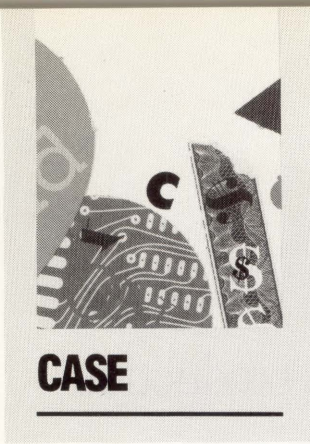

E XCELERATOR IN THE FAST LANE

By David B. Miller

**Index Technology's
Excelsator CASE
Product Helps
System Analysts
Design And
Implement Projects
At Light Speed.**

A significant case has been made for CASE tools in recent years, and products abound in the marketplace. All aim to make the job of the system analyst easier by providing the tools necessary to create, design and organize an entire system while at the same time supplying the mechanisms necessary to organize and track a project's multitudinous data.

Excelsator, from Index Technology Corporation of Cambridge, Massachusetts, is a tool designed to do just that. Its purpose is to allow you to design systems and organize all the data involved in a design project. It uses modern structured design techniques to let you create system graphs and charts, and to sample input screens and reports. Your design then can be analyzed for completeness and integrity. Changes and corrections that could require a lot of redesign effort can be made easily.

Requirements include a VAXSTATION with 4 MB of memory, 10 MB of disk space to run the product and an additional 1,000 blocks of disk space per project, VMS 4.4 or later and HCUIS 3.0.

Media is distributed on TK50 cartridges. VMSINSTALL is not used for the installation, but it's a straightforward process.

The Essential Excelsator

Excelsator's power can be realized by examining its major components and how they integrate to provide a high level of control over a system development project. For a descriptive illustration of these components, see Figure 1. In detail, these components are:

GRAPHICS — Six types of graphs are available:

1. Data Flow Diagrams.
2. Structure Charts.
3. Structure Diagrams — to display a system's flow and provide various levels of detail relating to the procedures and data comprising the project.
4. Data Model Diagrams — that describe entities of data and their structure.
5. Entity-Relationship Diagrams — to provide detail on the movement and changes that data go through within any one procedural module.
6. Presentation Graphs — to allow you to present the overall system definition to users and management.

Graph methodologies follow the principles of current popular thinking on structured design. Data flow diagrams can reflect the Gane and Sarson or Yourdon techniques. Entity-relationship diagrams follow the Chen or Merise methods. Default graphing methods are determined at project definition by the project manager, but you can convert a graph



F

FIGURE 1.

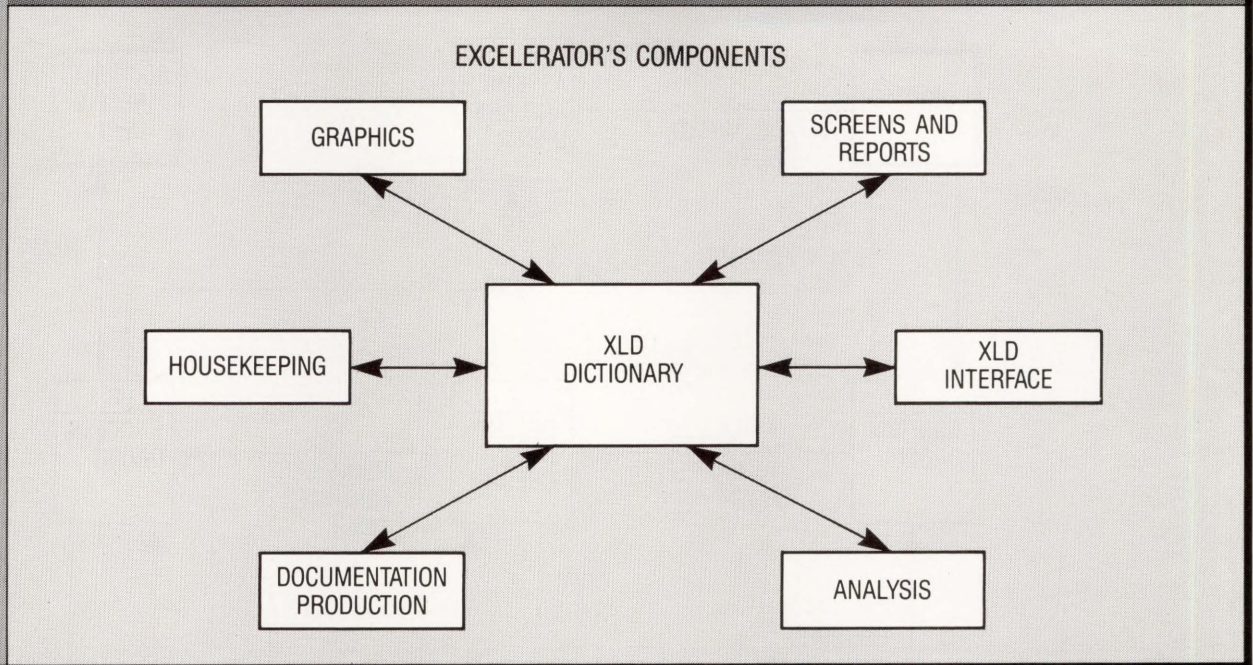

created with one methodology to another. A sample graph using Gane and Sarson symbols is shown in Figure 2.

Excelerator provides all the appropriate symbols (processes, data stores, external entities, etc.) for the selected methodology. These symbols can be connected, moved, erased, labeled and printed. Up to 10 explosion levels of detail are provided; Excelerator tracks the relationships and connections between levels.

A powerful feature of Excelerator's graphics is its interface to the project dictionary. Every part of a graph can be described to the central project database at the time you create it. Rather than draw the entire graph first and then enter your data in the dictionary, this "record-as-you-go" feature prevents loss or unnecessary duplication of data.

SCREENS and REPORTS — Excelerator allows you to create input screens and output reports that can be used for prototyping purposes with management and end users. As changes are suggested, you can alter your screen and report designs. A sample data entry screen is shown in Screen 1.

Screens can be designed with appropriate

titles, field descriptions and characteristics (length, decimal places, data type, etc.) and display attributes, such as reverse video, underlining and flashing. Editing and scope rules also can be specified for input fields to cut down on data entry error. Screens also can be chained, if one isn't enough. As fields are defined, all information about them is recorded in the project dictionary.

Screen and report design specifications can be translated to ASCII for integration with other computer systems. An appendix in the reference manual describes the format of the screen records in detail, so they can be translated properly back to actual screens on the target machine. Record layouts containing the fields and attributes used in screen and report designs can be generated in COBOL, PL/1, C and BASIC. These descriptions can be sent to disk files and included with program code.

XLDICTIONARY — Excelerator's data dictionary is the heart of the program. All information entered while working in other areas of Excelerator (e.g., Graphics or Screens and Reports) is collected in this central data repository.

Excelerator's components all interface with the project dictionary, Excelerator's core.

F

FIGURE 2.

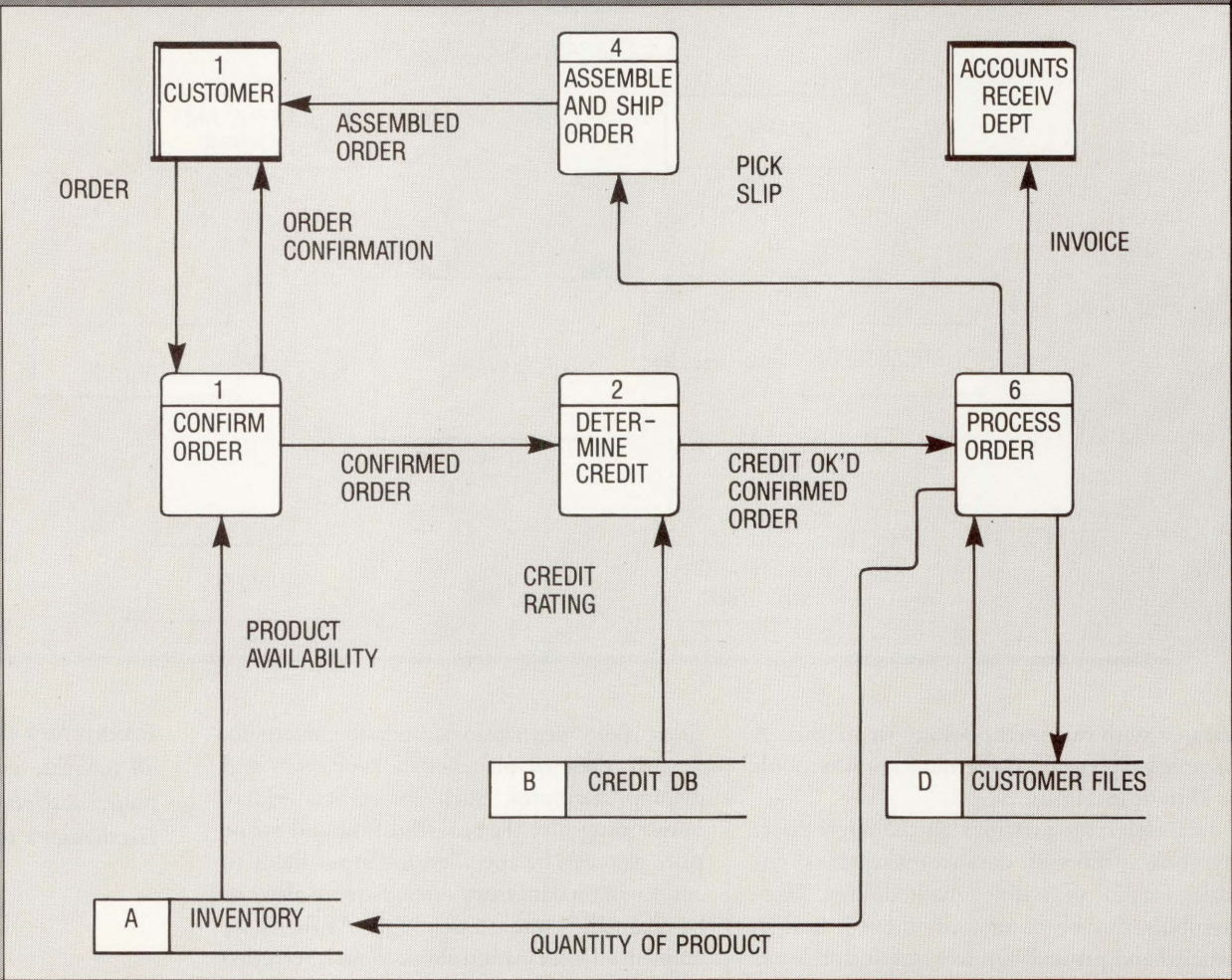

A sample Gane and Sarson data flow diagram.

Data is organized into entity types, which are data records that share common characteristics. Data flows, data flow diagrams, record elements, screen designs and presentation graph objects are examples of Excelerator data entities. All entities are assigned a three-character code to make group operations on them easier.

You can work with entities by accessing the central database directly. Operations that affect entities (e.g., RENAME) allow you the option of globally affecting other records in the database in which the entity occurs,

eliminating the need to change each occurrence manually.

Changes made in the Excelerator data dictionary also will be reflected in any graphs, screens and reports that contain that piece of information. Conversely, making changes (e.g., changing the name of a module in a data flow diagram) automatically will effect changes to all data dictionary records that contain that object.

Excelerator tracks all relationships among entities, such as those that contain other entities, graph objects that explode to other objects, the relationship between a report definition and a screen data file, etc. Audit attributes that list the

date of last modification (who, when), who created the entity, how many changes have been made to the entity and any locking mechanism currently in force are recorded for each entity. These relationship tracking and audit features provide a security mechanism to disallow simultaneous record access.

Another powerful data dictionary capability lies in its reporting features. The Report Writer allows you to obtain sorted and formatted listings of all or selected data dictionary records based on criteria you specify. This allows you to

FOCUS is the number one fourth-generation language on mainframes, minis, and micros.

Why? Because it actually does what a 4GL is supposed to do. And 400,000 users agree.

If you're skeptical, make us prove it.

Just give us a call and we'll come to your place, install FOCUS, and create a prototype application that (and here's the trick) runs against your production database.

Or, if you prefer, against FOCUS' own shared-relational database manager. Either way, we'll do it in four hours. At no charge.

What's more, we'll write the entire application in the FOCUS language—with no exits to COBOL, FORTRAN, or C for the hard parts. FOCUS is such a complete language you can use it to write almost any application—from heavy-duty transaction systems to any type of online inquiry system.

Moreover, FOCUS can directly access every major database system running on every major hardware platform.

the second machine, access any major database running there.

FOCUS supports IBM 370, PC and PS/2, VAX/VMS, UNIX V, Wang VS, and others. With, we might add, full portability. An application developed in any of these environments will immediately execute in any other.

That means, for example,

that you can use a PC as a workbench for mainframe application development.

SQL compatibility? However you need it, FOCUS can do it.

There's more.

Developers' Windows let your professional programmers use a windowed interface to create window-driven applications quickly and easily. The result is great-looking software with a superior user interface.

TableTalk is the FOCUS point-and-pick windowed interface that lets your end users create their own inquiries, customized reports, or even relatively complex applications—using only the arrow keys and the enter key.

And FOCUS lets you set the security and access levels you want.

**WE
AIN'T
#1
BY
ACCIDENT.**

We're talking about online access here, not merely batch data extracts. And FOCUS will address multiple databases simultaneously, and perform outer joins.

We'll take that a step further. If two computers communicate, a FOCUS user on one can, via FOCUS on

Sound too good to be true? It's not. But don't believe this ad. Make us prove it.

Who says we're number one?

"Information Builders' 4GL products were, once again, the only ones to lead in their niche in mainframes, minis, and micros. No other vendor has duplicated this feat in the seven-year history of this research effort."

—Software Magazine 1988 Software Market Survey

Just call 1-212-736-4433, Ext. 3700, and ask for details. And if you give the word, one of our technicians will come out to your place and make it happen.

Right before your eyes.

 **FOCUS**
Information Builders, Inc.

CIRCLE 126 ON READER CARD

ORDER INFORMATION

Order Number: AT071288ZZ Invoice #: B-1234 DATE: 07-12-88

Customer: DEC PROFESSIONAL Atten: David B. Miller

CATALOG	QUANTITY	PRICE	TAX
A12	1	10.99	Y
B32	5	4.59	Y
F16	2	37.00	Y

SHIPPING ADDRESS

921 Bethlehem Pike
Spring House, PA 19477

INVOICE ADDRESS

921 Bethlehem Pike
Spring House, PA 19477

Order Taken By: DBM Marketing Rep: XYZ Problems: NONE

3 EXIT 5 CUT 6 PASTE 7 REGION 8 REPEAT 9 DELETE 1,10 BLOCK 10 FIELD

Screen 1: Sample screen designs can be used to prototype live systems.

check the database for completeness and accuracy and will help you plug up any holes you discover in your project.

XLD INTERFACE — Excelerator's XLD INTERFACE gives you the control needed to share project data among other users, copy data to other projects and track all such movement of data to those individuals and projects.

The Export and Import facilities allow you and members of your design team to copy all or parts of the project's dictionary to other projects. A Locking feature can be enforced to protect specific data dictionary records from update by multiple users. A Preview feature allows you to view the data records to be modified before actually operating on them.

In a clustered environment, project data can be shared among multiple nodes across the cluster. RMS's record locking facilities ensure that multiple users can't modify the same record simultaneously. The VAXSTATION release notes indicated that multiple user access of project data provides limited protection at this point but should be improved in future releases. Although

multiple users can't modify the same record simultaneously, they can modify related records and dictionary entities. Therefore, it's recommended that procedures be established to monitor and review a project's data regularly.

Three levels of access determine the degree to which you can alter project data. READ users can look at data but not do much else. While working in Excelerator areas such as GRAPHICS and SCREENS and REPORTS, a READ user can only perform operations resulting in output.

LIMITED users have freedom to modify a project's data. A LIMITED user can perform actions on any record in the project dictionary as long as it's not locked by another user.

MASTER users have all privileges. For large projects with many smaller subprojects, MASTER access rights can be given to each manager for his particular project section.

ANALYSIS — Excelerator's analysis section provides the tools necessary to scrutinize your project design.

Graph analysis allows you to check for symbol omissions, redundancies and graph inconsistencies. A level balancing

feature checks for consistency between data flows on one explosion level and the data flows on subsequent levels. An explosion analysis lists all explosion levels (up to nine levels below the top), allowing you to trace all the connections and paths to and from various processes and entities on different levels. Excelerator never automatically changes anything about the system; it merely reports potential trouble spots and suggests how you can eliminate them.

Data dictionary items can be grouped into entity lists. You control what dictionary items are included in a particular group. For example, an entity list can contain record descriptions only. Or, you may need a list of all procedures within certain modules. Narrowing the list of required items allows you to concentrate on particular groups of data records rather than the entire dictionary.

The Report Writer feature can be used to generate hardcopy reports of the entities you select. Entity groups also can be analyzed as individual units and exported to other projects, making it easy to share selected data with other analysts.

HOUSEKEEPING — Housekeeping functions allow you to maintain the Excelerator environment and the projects on your system.

The amount of control each individual has over Housekeeping operations is governed by his access status. System managers have primary responsibility to maintain Excelerator's environment in regard to peripheral devices, system dates and authorized users.

Project managers exercise control of the project on the system and can add, delete, backup and modify projects and any associated project parameters. They can assign users (authorized by the system manager) to projects, granting them required access privileges (MASTER, LIMITED or READ). The last group, regular users, possess restricted access depending on what the project manager assigns to them.

INTRODUCING THE BRIGHTEST IDEA EVER IN VAX COMMUNICATIONS SERVERS.

The MAXserver™ 5000 from Xyplex.

Before you buy a terminal server, look at what Xyplex has to offer.

Xyplex introduces the MAXserver 5000, with more performance, more reliability, and more capability than anything Digital has to offer. All at a much lower price! Here are just some of the eye-opening facts:

Blazing performance. Digital's DECserver™ 500 is based on an old single-processor design so it slows down as you add users. But the MAXserver 5000 uses advanced parallel processing, so you get the same high performance with 120 users as you get with one user.

Shining reliability. Did you know that when one DECserver 500 component fails, the whole server can fail? Not with MAXserver 5000. Xyplex has designed it for uninterrupted service, with redundant

power supplies and multiple network interfaces. Plus our "hot-swap" serial cards allow you to change cards without disrupting the network.

LAN and WAN brilliantly integrated.

MAXserver even integrates both LAN and WAN, as well as TCP/IP connectivity, in one package. Its open architecture and expandable design means you'll be able to communicate with existing and emerging industry-standards, with simple, straightforward connections to UNIX-based systems.

A brighter approach to packaging.

The MAXserver 5000 can serve up to 120 users in one-sixth the space it takes with 8-port terminal servers. With computer room space at a premium, the MAXserver has a smaller footprint, uses less power, and gives you two or three times the number of ports as a DECserver 500 *in the same amount of space.*

See the price and see the light.

Here's the clincher: Xyplex offers all of the above advantages – and more – for a much lower price. See for yourself how Xyplex delivers more server for less money.

Shouldn't you find out about the brightest VAX communications server ever offered? Call Xyplex for complete product information and a free in-depth report comparing the MAXserver 5000 with the DECserver 500.

Xyplex and MAXserver are trademarks of Xyplex, Inc. DECserver is a trademark of Digital Equipment Corporation. UNIX is a trademark of AT&T Bell Systems. © Copyright 1988. Xyplex, Inc.



Xyplex, Inc.

100 Domino Drive
Concord, MA 01742
1-800-338-5316

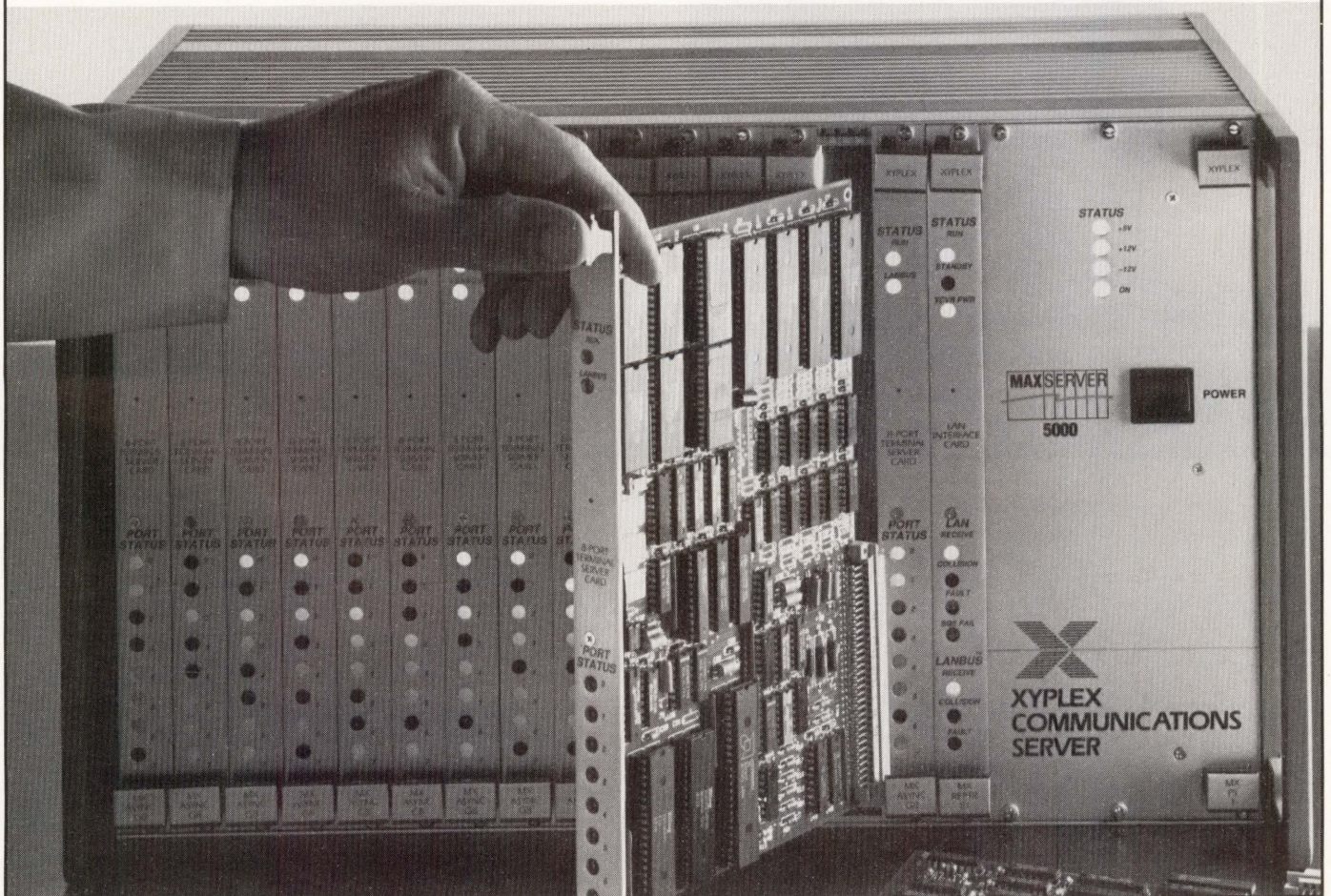

CIRCLE 171 ON READER CARD

The most versatile Graphics terminal Today!

GP-220 ZOOM



The GP-220Z...

- ▶ Graphics terminals lead a double life. They must have fast, flawless graphics capability as well as all the functionality of a high quality text terminal.
- ▶ But NDS terminals don't stop there. NDS engineers design in versatility in the form of innovative features.
- ▶ Features like 75 pages of off-screen memory, selectable text display modes up to 68 lines, on-line help, instant pan and zoom, and much more.
- ▶ The GP-220Z's new display list zoom feature adds another dimension of versatility. It outperforms the competition in speed, memory size and ease of use.
- ▶ The GP-220Z's new flat screen display and high definition video circuitry yield the sharpest, 1024 by 780 display available.
- ▶ The more time you spend evaluating graphics terminals, the more likely you are to buy NDS. Because when it comes to providing solutions, nobody does it better.
- ▶ Try out the GP-220Z on your own applications for two weeks. Call **1-800-537-1201**...and put us to the test.



**NORTHWEST
DIGITAL
SYSTEMS**

P.O. Box 15288
Seattle, WA 98115

(206) 524-0014

CIRCLE 305 ON READER CARD

Laser Sprinter.

The Talaris 1590-T enhanced performance printstation.

It prints out a 6800-vector plot with a running time of 6 seconds flat. Dashes off simpler graphics and text at its full 15 page per minute rating. Yet it's on track with a whole field of different users.

The 1590-T interfaces with a variety of computer systems, prints from most popular graphics packages, and has 42 built-in fonts, with hundreds more optional.

If you've got a multi-user environment with no room for a slow motion printer, sprint for the phone. Get the inside track on a winner.

P.S. Time trials now in progress. Send us your slowest VAX/VMS[®] output file, and we'll print it out in record time. Call for details.



TALARIS
SYSTEMS INC.[®]

(619) 587-0787
6059 Cornerstone Court West
P.O. Box 261580
San Diego, California 92126

CIRCLE 162 ON READER CARD

VAX and VMS are registered trademarks of Digital Equipment Corporation.



Excelerator's documentation is extensive, as well as attractive.

DOCUMENTATION — Documentation often is put off until the end of the project's design and often isn't given the attention it deserves. Let's face it, writing documentation is boring; besides, you know how the system works and can explain it better verbally than in writing. Nevertheless, documentation is a critical part of any system and can't be neglected.

Fortunately, Excelerator removes some of the pain of producing documentation. First, you draw a Document Graph, a tree-like diagram that depicts the documentation's overall structure, content and flow, similar to drawing a structure chart. This graph can be analyzed for completeness and logical integrity before producing a final copy. When no errors are found in the document's graph, hardcopy can be produced.

Data for the documentation can be retrieved from the XLDICTIONARY entities (record layouts, screen definitions, graphs, etc.) and from ASCII text files created with a word processor. The order in which these parts are integrated into the final product is determined by your document graph layout.

It's not difficult to see the advantages in having this facility. Items, such as record descriptions and graphs, don't

have to be reproduced manually for the documentation; simply get the needed data from the dictionary. Text files can be created anytime you like and can be incorporated into the documentation wherever needed. The required Document Graph that you initially create helps you organize the flow of the major sections and think about the amount and type of documentation needed for the project.

Although documentation might remain last on your list of priorities, Excelerator's capabilities help alleviate the strain of producing it.

Additional Features

You've worked long and hard designing a system. But, you need to be able to recover data in the event of a crisis. You also need hardcopy of graphs and reports for presentation to management and users, as well as for your own records.

In the event of data corruption, Excelerator's FIXPROJ utility can rebuild the project dictionary and other important project files. A subprocess of FIXPROJ, CTRBLD, can be invoked directly to rebuild selected project files, if you know that only a file or two has been corrupted.

Excelerator

Index Technology Corporation
One Main St., 9th Fl.
Cambridge, MA 02142
(617) 491-2100
Price: \$8,400 with quantity discounts
CIRCLE 554 ON READER CARD

Printing support includes the normal VMS print queue as well as printing to files. For graphics files, Excelerator allows you to create UIS metafiles that are in a format compatible with the VAXSTATION's RENDER command, or you can print directly to an LN03 or compatible laser.

Documentation

Excelerator's comprehensive documentation includes a *Reference Guide*, *User's Guide* and *Tutorial*. Because these were written with the IBM PC in mind, it's a good idea to keep the VAXSTATION addendum and Release Notes close by for reference, especially for such things as key locations and printing procedures.

Resist the temptation to use Excelerator as a graph drawing program; less expensive graphics packages can do that. Use Excelerator and all its capabilities to derive the maximum benefit for you, your management and end users. Excelerator provides the facilities to design a project correctly and completely from the start; it would be a shame to ignore those features.

Although Excelerator won't produce an expert system analyst from a junior programmer, it will go a long way in helping experienced system analysts concentrate on the real work of analyzing and planning, rather than wasting time worrying about clerical duties or lost and jumbled project data.

If you're fortunate enough to own a VAXSTATION and if you're looking for a solid, flexible and comprehensive CASE package with which to do systems analysis and design, take a look at Excelerator; you won't be disappointed.

ARTICLE INTEREST QUOTIENT
Circle On Reader Card
High 551 Medium 552 Low 553

There Are No Risks When You Buy A VT320™ From Scherers

No longer do you have to risk system compatibility when you make your next terminal purchase decision.

No other vendor can insure forward and backward compatibility like Digital can. With the VT300™ family of terminals, you can have Digital products and on-going systems support, at a competitive price.*

Moreover, buying Digital from Scherers insures that you get all the value-added services you demand. The safest product choice, from the best source. You can't lose.

Product availability and local support are critical to the success of your business. Scherers responds with same

day delivery, direct sales presence and technical expertise on products of the highest quality, packaged with the best warranties.



THE ORIGINALS

The best product and distribution formula is brought to you by Scherers. Call us.

Our track record is built on **total customer satisfaction**. All of which explains why your next computer terminal decision is an easy one. Why not buy the original from Scherers?

SCHERERS
COMMUNICATIONS

We bring Digital to you.

(614) 889-0810

*If you haven't priced a VT320™ lately, you'll find it's priced lower than the competition. Call us.

ILLINOIS
Chicago Branch Office
Opening Soon!

MICHIGAN
Detroit Branch Office
(313) 462-2046

PENNSYLVANIA
Pittsburgh Branch Office
(412) 854-2666

WISCONSIN
Milwaukee Sales Office
(414) 357-6555

KENTUCKY
Louisville Branch Office
(502) 456-4898

MINNESOTA
Minneapolis/St. Paul
Branch Office
(612) 854-9101

OHIO
Columbus Branch Office
(614) 889-0810
Cincinnati Branch Office
Opening Soon!

digital™
Authorized Distributor

WHAT A
DISTRIBUTOR
SHOULD BE.

**38 NEW SALES
OFFICES OPENING IN 1988!**

VT320™ is a registered trademark of Digital Equipment Corporation

Token Recognition

Editor's note: The C language grammar is very elegant and quite unambiguous, particularly with regard to token recognition and parsing. In this installment, Mr.

Jaeschke explains tokens and their recognition and offers a few examples of unexpected problems.

A token is the basic element of a C source program. The complete set of C's tokens are keywords, identifiers, constants, string literals, operators and punctuators.

White space is used to separate tokens, although it isn't always necessary. (White space can appear inside a token only if that token is a string literal or character constant.) A close look at C's grammar shows that it's designed unambiguously. You can take an arbitrary correct program, remove all white space separating tokens, and except for some unusual circumstances, it still will compile. Examples in the grammar are:

```
for (exp1; exp2; exp3)
while (exp1)
switch (exp)
if (exp)
do ... while (exp)
```

In all cases, the expressions must be placed inside parentheses. These parentheses aren't part of the expressions but are part of the syntax of each of the corresponding statements. So, the presence of white space before and/or after the (and) tokens is immaterial. (Note that in **return (exp)**, the parentheses aren't required syntax of the **return** statement. Here, they are redundant grouping parentheses and are part of the expression.)

Another example of how the language design helps token recognition is with octal and hexadecimal constants. Only arithmetic constants can begin with digits, so the use of 0 and 0x (or 0X) prefixes is reasonable. (However, it's not known whether the sequence 012345678.9 is an octal or double constant until the digit 8 is seen, but that's a minor complication.) There's another way these constants could have been written, using a base suffix.

As a quick and theoretical question, if a parser sees the token 0, is that octal zero? It does have a leading zero. (Note that 0x and 0X aren't valid hex constants; zero must be written as 0x0 or 0X0.)

There are a few cases where you likely will get syntax errors or at least unexpected behavior, if all white space that

separates tokens is omitted from a program. So, for the most part, C is a free-form language where white space is optional. However, there are a few places where white space (or something else) is needed to help the parser recognize tokens as you intend. Let's look at some of these cases.

The Autoincrement Problem

A C translator must form the longest possible token it can. A token is terminated when either white space is found or the next input character can't be part of the token being formed. For example, if the input stream contains **doi = 10**, C must recognize **doi** as an identifier being assigned the value of 10. It can't interpret this as the **do** keyword followed by an assignment of 10 into the variable **i**. (If you're familiar with FORTRAN, you know it recognizes DOI=10 as the start of a DO loop.)

Consider the following example:

```
main()
{
    int i = 10;
    int j = 5;
    int k;

    /*1*/ k = i++ + ++j;
    /*2*/ k = i ++ + ++ j;
    /*3*/ k = i+++ ++j;
    /*4*/ k = i++ +++j;
    /*5*/ k = i+++++j;
}
```

Statement 1 is correct; the tokens are obvious. They are **i**, **++**, **+**, **++**, **j** and **;**, and the statement compiles without error. So does statement 2, because the extra white space doesn't change the tokens seen by the scanner.

In statement 3, the space between the increment and the binary add operators has been removed; however, the scanner forms the longest possible token sequence and correctly comes up with the same tokens as in the first two cases.

Statement 4 results in a compilation error concerning a missing lvalue. Let's look at the tokens found. They are **i**, **++**, **+**, **+**, **j** and **;**, which is different. The reason for the error is that the compiler sees the variable **i** with two postfix auto-increment operators applied to it; i.e., it sees **(i++)++**.

Now the result of the expression **i++** is the value of **i** before it's incremented. The important thing is that this expression generates a value, not something that has an address. Therefore, the expression **i++** isn't an lvalue; it doesn't

designate a memory location to which we can write, although **i** itself is an lvalue.

ANSI C has added a unary plus operator, just like unary minus, causing the above token sequence to generate the same error, because it sees `++(+j)`, a prefix increment of a unary plus expression. Because `+j` isn't an lvalue, it can't be incremented. Whichever way the grammar handles it, it's an error.

Statement 5 is parsed the same as statement 4, so it also generates a syntax error. Of course, a similar problem arises with `i----j` and `i++---j`.

The Pointer Problem

Another tokenizing problem can occur when dereferencing pointers as follows:

```
#include <stdio.h>

main()
{
    int i = 10;
    int *pi = &i;
    int j;
    int k;

    printf("Program start\n");

    j = 30/*pi;

    for (k = 0; k < j;
        printf("k = %d\n", k), ++k)
/* null statement */
        printf("Program end\n");
}
```

Here, we divide the integer 30 by the integer value pointed to by **pi**, namely, 10. This should assign 3 to **j**, and the **for** loop should run from 0 through 2, producing three displayed values of **k**. However, the output is:

```
Program start
Program end
```

The **for** loop doesn't seem to have been executed. See the problem? Just for fun, let's put the comment after the null statement, rather than before it. The source line now should look like:

```
; /* null statement */
```

Now we get a syntax error. The compiler complains about the line:

```
printf("Program end\n");
```

saying that a semicolon was expected, yet the identifier **printf** was found instead. The problem lies with the source line `j = 30/*pi;`.

Let's look at the tokens seen by the parser. They are **j**, **=**, **30**, **,**, *****, **pi** and **;**. Actually, `/*` begins a comment, and the

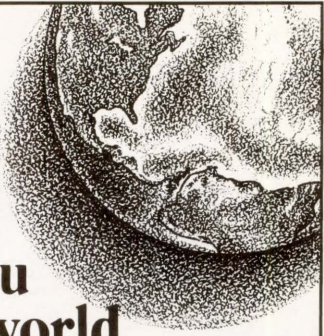

GURU®

When you expect the world from your expert system.

Tired of being limited? It's time to discover GURU—an expert system environment with comprehensive inference engine and rule management controls.

Incredible flexibility.

GURU lets you design an expert system that runs exactly the way you want. By using fuzzy variables, certainty factors, reasoning rigor, rule selection order, and numerous environmental and utility variables, you have virtually unlimited control over the consultation environment.

Unprecedented development efficiency.

Using GURU's case saving and replay, you can track the effects that rule changes have on system behavior. You can also use meta rules to examine or alter other rules during a consultation. And using GURU's knowledge tree, you can display the relationships and dependencies between an application's rules, variables, and goals.

Quick and thorough.

By mixing forward and backward chaining, goal search time can be shortened dramatically. And, using GURU's multiple rule firing capability you can re-fire rules as values change. GURU also comes equipped with seamlessly integrated 4th generation decision support capabilities such as data base, spreadsheet, and report generator.

GURU runs on PCs, LANs, and VAXs.

To find out how GURU can exceed your expectations, call 1-800/344-5832 or 317/463-2581.



P.O. Box 248
Lafayette, IN 47902
1-800/344-5832
317/463-2581

Explore the world of expert systems with GURU Tutor!

This full-featured development environment allows you to prototype GURU applications using rule sets, data bases, spreadsheets, and more for only \$75. To order, call us at 1-800/344-5832 or write. VISA, MasterCard, and American Express accepted.

GURU is a registered trademark of mds, Inc. VAX of Digital Equipment Corp.

CIRCLE 137 ON READER CARD

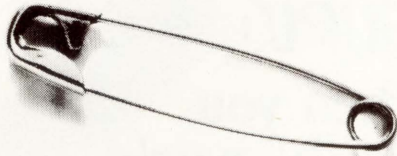

Some of the best ideas don't cost a fortune.

Take the safety pin. The old saying, "You get what you pay for," sure doesn't hold true for it. They're simple. Inexpensive. And do the job. Just like Business Computer Services **DOWN TO EARTH** accounting system.

BCS provides fully integrated business software including:

Accounts Payable
Purchase Order
Inventory
Payroll
Report Writer
Sales Analysis



Accounts Receivable
General Ledger
Order Entry
Job Cost
Bill of Materials
Resource Scheduling



If that wasn't enough, our packages:

- have standardized code to help in the maintenance of the applications.
- are adaptable to various working environments.
- have online help in addition to a user manual.
- operate on a variety of systems including VMS, UNIX, XENIX, MS-DOS.

For more information call **Business Computer Services** at 405-843-8631. Or write us at 6801 N. Broadway / Oklahoma City, Oklahoma 73116.

Don't get "stuck" with expensive software. Just because it costs more doesn't mean its worth more.

- Coming Attractions
- General Ledger account allocation. Accounts Payable duplicate invoice checking. Accounts Receivable sales tax supports four breakouts of tax rate. Inventory pricing based on cost markup. Ordering by vendor/vendor part number.

DBL... more than just a language.

"When I chose to develop my applications in DBL, I didn't realize I was making an excellent marketing decision as well. Not only is DBL easy to learn, easy to use, and easy to maintain, but it allows me to sell my applications on almost any hardware my customer chooses . . . and I only need to maintain one set of sources. DBL is more than just a language . . . it's an important part of my business."



*Merrill Likes
Business Computer Services*



Digital Information Systems Corporation
11070 White Rock Road, Suite 210
Rancho Cordova, California 95670
(916) 635-7300
FAX (916) 635-6549
TWX 910-367-3701

CIRCLE 227 ON READER CARD

matching end comment *****/ isn't seen until several lines later. Because C doesn't permit nested comments, no error is produced. The null statement causes the token sequence to be **j, =, 30** and **;** with the intervening comment being replaced by a space. So when the comment is moved, the semicolon becomes part of the comment, and the token sequence seen is **j, =, 30** and **printf**, which generates the syntax error because you never can have a identifier following a constant.

This problem can be solved by placing a space between the **/** and the ***** so they're seen as two tokens representing division and pointer indirection, respectively as follows:

```
j = 30/ *pi;
```

However, this can cause a problem in the future, if some unsuspecting maintenance programmer removes the space. A better solution is to use:

```
j = 30/( *pi );
```

possibly with a comment. This looks sufficiently unusual to attract attention. By using redundant grouping parentheses, we've forced the intended tokens to be recognized.

Building Tokens With Macros

Consider the following example:

```
#define A -1  
#define B 10  
  
int i = B-A;
```

If you run this through a preprocessor and look at the expanded code, you might see:

```
int i = 10--1;
```

and we would expect this to generate a syntax error, because we're trying to increment a constant and that's not an lvalue.

This doesn't happen if the preprocessor and compiler are talking to each other as they usually are in implementations. When processing C source, we have "phases of translation." This is a series of steps followed by the translator, and it dictates the order in which they must be performed. ANSI C has specified these phases in detail, because it's an area of significant differences between existing implementations.

According to the phases of translation, the source is broken into tokens before preprocessing macros are expanded, so the expression initializing **i** contains the tokens **B, -** and **A**. When the macro **A** is expanded to **-1**, the unary minus token is seen along with the constant one. There is no way the binary subtraction operator and the unary negation operator can be considered as the decrement operator, because the tokens already have been formed before the expansion. If you

preprocess the source and save the expanded code in a disk file, you'll get a syntax error when you compile that intermediate output, because the characters -- will be recognized as the decrement operator instead.

Over the years, some implementations have been extended incorrectly to allow tokens to be created as follows:

```
a/* */b
```

Here, the comment was replaced incorrectly by nothing rather than a space, resulting in the token **ab** being seen rather than **a** and **b**. ANSI C doesn't permit this but has recognized the possible need for building tokens during preprocessing. For this reason, ANSI C contains a special preprocessor-only operator **##**. This is referred to as the token pasting operator and is used as follows:

```
a ## b
```

The white space is irrelevant, and the two tokens **a** and **b** are interpreted as if you had written **ab** directly. The advantage of this is that **a** and **b** can be macros that expand to arbitrary strings that can be pasted together subsequently to form larger tokens.

The Mysterious for Loop

Consider the following, seemingly innocent program compiled and run with VAX C V2.3:

```
#include <stdio.h>
main()
{
    int i;
    printf("Let's loop a bit\n");
    for(i=-5; i<5; ++i)
        printf("i = %d\n", i);
}

Let's loop a bit
i = -1
i = 0
i = 1
i = 2
i = 3
i = 4
```

The output seems to be incomplete; the loop seems to begin at -1 instead of -5. (The starting point of your output may vary from that shown.)

Let's compile, link and run with VAX DEBUG included:

```
VAX DEBUG Version V4.6-9
%DEBUG-I-INITIAL, language is C,
module set to xx
DBG> g
Let's loop a bit
```

Gone as far as your data base can take you? MDBS III[®] can take you further.

You know the situation. You need to develop a system that will handle massive amounts of data and involves complex data relationships. And not only do you need it in an unreasonable time, it has to run on a PC or a mini. And on top of that, your current dbms simply can't handle the job.

Design real world schemas.

MDBS III supports data bases into the hundreds of megabytes and beyond, yet you can still retrieve data in split-seconds.

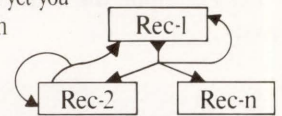

You can design a data base to represent

structures as they are in the real world, capturing many-to-many, one-to-many, many-to-one, one-to-one, forked and recursive relationships. There's no time-wasting, space-hungry dummy records or extra coding. Every time you modify your data structure, MDBS III modifies your data base automatically.

Develop more efficient applications.

MDBS III offers high performance with flexible data-structures, airtight data integrity, automatic recovery, password, encryption and read/write protection, transaction logging, spur-of-the-moment query, report generation, easy schema restructuring, and much, much more.

From PCs to LANs to VAXs, see how far MDBS III can take you. Call 1-800/344-5832 or 317/463-2581.



P.O. Box 248
Lafayette, IN 47902
1-800/344-5832
317/463-2581

Technical specifications

- records/data base — unlimited
- fields/record — 32,767 • max db size — 4GB • records/set (file) — unlimited • fields/index — 32,767 • indexes/record — 2,500 • access codes — 65,535
- plus performance tuning, significantly reduced storage requirements, clustering, multi user, multiple language I/Ps

MDBS III is a registered trademark of mdbs, Inc. VAX of Digital Equipment Corp.

CIRCLE 138 ON READER CARD

```

i = -5
i = -4
i = -3
i = -2
i = -1
i = 0
i = 1
i = 2
i = 3
i = 4
%DEBUG-I-EXITSTATUS, is '%SYSTEM-S-NORMAL,
normal successful completion'
DBG> exit

```

With DEBUG, the program seems to be working. Let's take a look at the code generated in the listing file. The really important bit is:

```

for(i=-5;i<5;++i)
    subl2 #5,r2
    cmpl r2,#5
    bgeq sym.2

```

The subtract instruction `subl2` looks suspicious; it seems that 5 is being subtracted from register `r2` and compared with 5. Apparently, `r2` is being used to store the variable `i`, yet it's not being initialized to -5 as we requested. There's the problem. Let's compile the source again with an extra switch as follows:

```

$ cc test/standard=portable
# include stderr
%CC-I-NONPORTINCLUDE, #include of a library
module is not portable. At line number 6 in ...

extern volatile int noshare errno;
/* UNIX style error code */ %CC-I-NONPORTCLASS,
Storage class "noshare" is not portable. At line
number 9 in stderr.

extern noshare FILE *stdin, *stdout, *stderr;
%CC-I-NONPORTCLASS, Storage class "noshare" is
not portable. At line number 35 in ...

for(i=-5;i<5;++i)
%CC-I-ANACHRONISM, The "=-" operator is an
obsolete form, and may not be portable. At line
number 9 in ...

%CC-I-SUMMARY, Completed with 0 error(s), 0
warning(s), and 4 informational messages. At
line number 12 in ...

```

Bingo! “%CC-I-ANACHRONISM, The “=-” operator is an obsolete form.” The compiler has interpreted the characters `=-` as an operator, when no such operator currently exists in the C language, even though it did in the past. The following is taken from page 212 of Kernighan and Ritchie's *The C Programming Language*, referred to throughout this series as K&R, under the heading “Anachronisms:”

“Earlier versions of C used the form `=op` instead of `op=`

for assignment operators. This leads to ambiguities, typified by:

```
x--1;
```

which actually decrements `x` since the `=` and `-` are adjacent, but which might easily be intended to assign -1 to `x`.”

VAX C V2.3 still supports these old-style operators, even though they were considered outdated in 1978 when K&R was written. So the subtract instruction is correct; however, the problem is that `i` is an automatic variable and, therefore, has an undefined initial value. Subtracting 5 from an undefined value can result in a wide range of answers. If `i` became -1000, the loop would have run from -1000 to 59. If `i` started as -6, it would become -1, and the loop would run from that through 5. If `i` started out with a value of 11 or more, the loop never would be executed, because `i` already would be greater than 5.

Why does the same program work with DEBUG? That's a quirk of fate. The debugger seems to initialize the stack area where the automatic variable `i` lives, to zero. So the undefined initial value of `i` is zero, and `0 - 5` results in the same value as if you had assigned -5 to it. However, the subtract instruction still is generated, so you get the answer you expect.

To fix it, write the loop as follows:

```
for(i = -5; i < 5; ++i)
```

I've thrown in some extra spaces as well as the one required between the `=` and `-`. Because the C compiler is obliged to form the longest possible token it can, and a token can't include white space, the space between the `=` and `-` forces the compiler to see the assignment and the unary minus operators.

The `/standard=portable` switch is useful and I encourage you to use it. Many programmers compile using a command procedure, and they put this switch inside it on the compiler command line. However, it can generate noise (as shown) that's confusing and irrelevant. It complains about non-standard things that exist in the VAX C-supplied headers, like the `volatile` and `noshare` keywords, and the use of the VAX C `#include` syntax used for text libraries.

If you were porting the program, you wouldn't be porting the VAX C header `stdio.h`; a new version would be provided by the target compiler. So whether or not it contains non-standard stuff is irrelevant. VAX C doesn't recognize `stdio.h` as special; it's just another header possibly written by the programmer.

Even though this switch can generate a large amount of such irrelevant messages, it's worth the effort.

More Anachronisms

A related example follows. Again, it's a seemingly straightforward program:

RABBIT-2: A Decision Support System For VAX/VMS® Data Center Managers

With RABBIT-2 You Become a VMS Know-It-All!

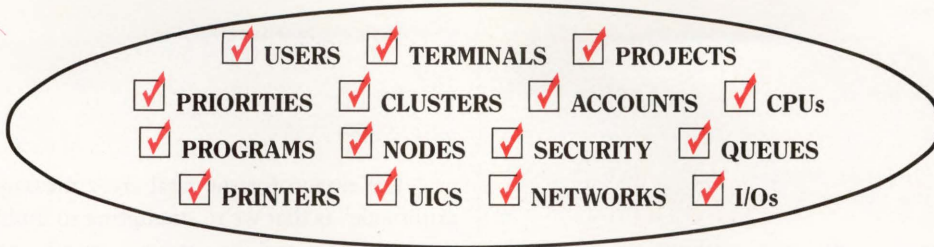

Powerful. . .

RABBIT-2 VMS KNOW-IT-ALL provides the right answers to vital VAX/VMS Data Center Management questions. From determining hardware upgrade needs to identifying resource-wasting software. Enhancing programmer productivity or trapping security breeches. Examining and correcting bottlenecks and anomalies. Justifying and supporting resource allocation.

THE ONLY LIMIT IS YOUR IMAGINATION!



. . . Yet Easy to Use!

RABBIT-2 quickly and easily delivers 1000s of revealing, precise, problem-identifying Analyses, Reports and Graphics. Innovations like RABBIT-2's Split-Screen windows and Definition Phase let you effortlessly custom tailor your investigations and examinations for your environment.

RABBIT-2 Lets You "Know It All" About Your VAX/VMS System.

Capacity Planning. . . System Performance Analysis. . . Decision Support. . .
 Program Performance Analysis. . . Security. . . User Productivity. . .
 Trend Analysis. . . Load Balancing. . . System Tuning. . . Cost Justification. . .
 Project Allocation Reporting. . . THE ONLY LIMIT IS YOUR IMAGINATION!



COMPUTER INTELLIGENCE

Computer Intelligence recently declared RABBIT-2 the #1 selling independent capacity planning tool worldwide.

Call Today for Your Free Demo!

RAXCO USA
 (301) 258-2620

RAXCO CANADA
 (301) 371-5020



"The VAX/VMS Performance Experts"

CIRCLE 249 ON READER CARD

VAX, VMS are registered trademarks of Digital Equipment Corporation

```
#include <stdio.h>
main()
{
    int i = 100;
    int j;
    int *pi = &i;
    j=*pi;
    printf("j = %d\n", j);
}

j=*pi;
%CC-E-INVPTRMATH, Invalid pointer
arithmetic. At line number 9 in ...
```

This time, an error results even without the standard switch. With the switch, the compiler generates the extra message:

```
j=*pi;
%CC-I-ANACHRONISM, The "==" operator is
an obsolete form, and may not be
portable. At line number 9 in ...
```

Again, the solution is to separate the = and * with whitespace:

```
#include <stdio.h>
main()
```

```
{
    int i = 100;
    int j;
    int *pi = &i;

    j = *pi;
    printf("j = %d\n", j);
}

j = 100
```

The reason for the fatal error message "Invalid pointer arithmetic" is that we're attempting to multiply a pointer with an expression, and it's a syntax error to involve a pointer expression in multiplication. The only arithmetic operations permitted with pointers are addition and subtraction of integral expressions, and the subtraction of one pointer from another pointer where both pointers are of the same type. Also, this only makes sense if both pointers point to elements of the same object.

The complete set of compound assignment operators is +=, -=, *=, /=, %=, >>=, <<=, &=, |= and ^=. If you swap them around so the = is at the front, you have the complete set of old-style operators. VAX C supports them all, both old and new. —*Rex Jaeschke is an independent consultant, author and lecturer. He is the C language editor of DEC PROFESSIONAL and our representative on the ANSI C Standards Committee.*

KEEP UP IN A CHANGING WORLD

Take advantage of the wealth of knowledge available from your Government. The U.S. Government Printing Office has produced a new catalog. It tells about the most popular books sold by the Government—nearly 1,000 in all. Books on agriculture, business, children, diet, energy, health, history, space, and much more. For a free copy of this new catalog, write—

New Catalog

Post Office Box 37000
Washington, D.C. 20013

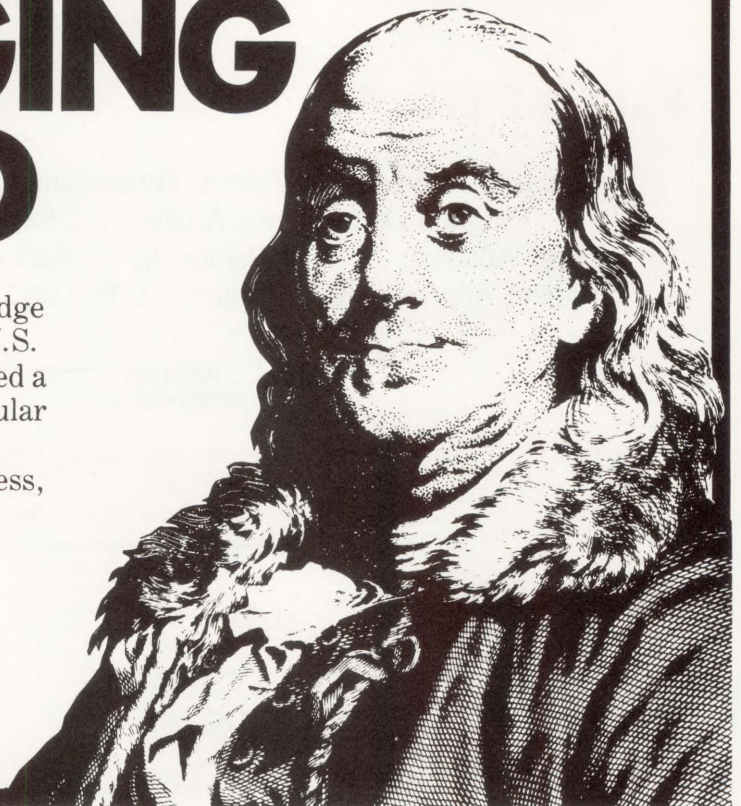

Pure and simple:

NO RUNTIMES— EVER!

CHARM

The C Source Database Application Generator

The efficiency and power of an interactive ULTRIX™ RDBMS... The flexibility of complete applications in standardized C source code... in one package:
That's CHARM!

CHARM'S UNIQUE PRODUCT FEATURES:

• **INTEGRATED DEVELOPERS WORKBENCH...**

- fully relational DBMS
- interactive menu, screen, report and batch program generator
- built-in C-like 4GL option (for those unique situations)
- application design, C code generation, compilation, testing and execution

...ALL WITHIN THE FOUR CORNERS OF THE CHARM SCREEN!

• **CHOOSE YOUR DATABASE ENGINE—**

Now integral support for UNIFY™ files as well!

• **PLUS: CHARM-GENERATED SOURCE CODE IS FULLY PORTABLE**

ACROSS ALL UNIX™ PLATFORMS—NO RUNTIME MODULES OR FEES—EVER!



VERSION 1.6
NOW AVAILABLE!

Everything you need,
at a price far below
the "getting started"
prices of other
RDBMS systems

MICROVAX II
\$6995

PREVIEW PAK
FOR DEC PLATFORMS
\$500
(Fully applicable to
CHARM purchase)

VAX 780, 8500
\$9995

(Available for all popular UNIX V, BSD and ULTRIX™ systems)

CALL OR FAX IN YOUR ORDER RIGHT NOW:

(MC, Visa, Corporate P.O. accepted)

TOLL-FREE (800) 451-8424 / In New York (212) 422-4100 / Fax (212) 809-7206

CHARM

The "no runtime" answer to cost-effective software development!

WorldWide Data Corporation • 17 Battery Place • New York NY 10004

How
to
avoid
your
next
BRU...

SQUEEZPAK[®]

RSX

On-Line Disk Optimizer

**Makes Files and Free
Space Contiguous**

Field Proven on Hundreds
of Sites

Fully Transparent On-Line
Operation

**CALL TODAY For a
FREE Evaluation !**

1-800-267-1590

1-800-634-6552 (California)

DEMATIC
SOFTWARE LTD.

CIRCLE 115 ON READER CARD

RSX CLINIC

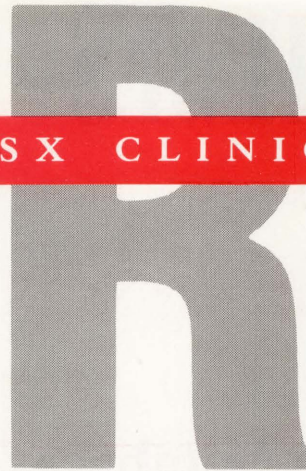

By James A. McGlinchey

NOT ANSI D FORMAT

QUESTION: *I PIPed some regular ASCII files to a mag tape using RSX-11M V3.2. When attempting to read them on VAX/VMS 4.7 using COPY, I received the error message, "Not ANSID format." What does this mean, and how can I get around it?*

REPLY: It means what it says: Your files on the tape aren't ANSI D format.

Several procedural errors could bring about this result. Did you SYSGEN your system with ANSI mag tape support? It was an option on your version. If not, go back and do another SYSGEN. Is the mag tape ACP (MTAACP and F11MSG) installed? If not, install both tasks with the INS utility and try again. Did you initialize the tape as an ANSI volume? If not, INI it. Did you rebuild your PIP utility with the ANSI mag tape FCS library? Your version requires this manual step. Go back to your distribution kit, and copy the necessary files to task build the PIP utility. Change the task-build command file to use ANSLIB.OLB, rather than SYSLIB.OLB, as its default library; then task build PIP.

It also could be a bug. RSX-11M V3.2 didn't produce a perfect ANSI D format

tape. It was the first version of RSX to support ANSI tape formatting. The permanent fix is to upgrade your system to the current version. I suspect, however, that you're married to version 3.2 for unmentioned reasons and must resort to the workaround: FLX. Actually, I shouldn't call this a workaround, because many RSX users prefer it to the ANSI format for mag tapes. Create a DOS-11 format tape with the following commands on your RSX-11M 3.2 system:

```
FLX MM0:/ZE(initializes the tape)FLX  
MM0:/DO = [uic]Filespec(s)/RS
```

It's that simple. Use the EXCHANGE utility on your VMS system to read the files from the tape:

```
MOUNT/Foreign MM0:  
EXCHANGE Copy MM0:  
  [*]*filespec(s)/Volume__format =  
  DOS 11 [ ]  
DISMOUNT MM0: ■
```

Meet the technology
leaders in

Computer Graphics

—at the Invitational Computer
Conference near where you live
and work.

The Computer Graphics market is growing so fast it's hard to keep up with the products and trends you need to know about for informed quantity purchase decisions. So we make it easy for you—at the Invitational Computer Conference (ICC), the one-day, seminar/product displays that bring the latest information on computer graphics hardware and software technology and products to your area. This year there are eight ICCs dedicated exclusively to the computer graphics systems integrators, OEMs and volume end users in the United States and Europe. One will be convenient for you.

The ICCs are so popular because they give you just what you need to know without wasting your time or money. You don't travel far, there's no admission fee, the seminars and table-top displays from major manufacturers are all targeted to your interests (no searching through aisles), and the atmosphere is informative and hands-on, but congenial, with refreshments served. In a few hours you'll have the latest story on the newest and best in graphics, CAD/CAM/CAE/CIM/CAP, etc.

Invitations to the ICC in your area are available from an exhibitor or the ICC management. Request yours today.



1988/89 Computer Graphics Series

U.S. Locations

Chicago, IL	Sept. 21, 1988
Irvine, CA	Oct. 4, 1988
Dallas, TX	Oct. 20, 1988
San Jose, CA	Feb. 6, 1989
Newton, MA	Feb. 15, 1989

European Locations

London, England	May 11, 1989
Frankfurt, W. Germany	May 17, 1989
Paris, France	May 23, 1989

ICC Conference Management:
B. J. Johnson & Associates, Inc.
3151 Airway Avenue, C-2
Costa Mesa, California 92626
Telephone: (714) 957-0171
FAX: (714) 957-0903
Telex: 5101002189 BJ JOHN

European Liaison Office:
C. J. Nicholl & Associates Ltd.
37 Brompton Road
London SW3 1DE, England
Telephone: 01-581 2326/9
FAX: 1-589 0893
Telex: 888068 CJNAD G



X11 Toolkit Extensions

Let me share a not-so-big secret with you: DEC has

poured more money and resources into DECWINDOWS development than any other software project in its history.

The undertaking spans the VAX chip set, the Intel processor, three operating systems (ULTRIX, VMS and MS-DOS), all the workstation hardware and all the muscle in DEC's internal application development.

The reason for the commitment is simple: DEC feels that the X Window System and its subsequent extensions are the vehicles through which we'll make the final break from a timesharing world to a distributed processing world. It's betting its fortune on distributed processing.

In the near future, DEC workstations will be able to transparently access applications residing on other vendors' hardware, if they're also supporting an implementation of the X Window System.

X Version 11

MIT, the proprietor of the X Window System, is telling the world that the basic structure of the current X Version 11 is permanent. It will be tweaked, debugged and rereleased constantly, but it defines every aspect and technicality of a uniform programmer and user application interface.

For now, hardware from many manufacturers is being sold with the unvarnished X11 tape from MIT. DEC workstations running under ULTRIX, for example, have pure X today. But you can expect proprietary, platform-customized extensions to X11 from all

the major consortium members: DEC, IBM, Sun, Apollo, Hewlett-Packard, Tektronix, etc. Everyone seems to be shooting for release dates around November or December.

DEC's extension of X, tentatively called DECWINDOWS internally, will be

“

DEC probably can rest assured that few other vendors are trying to integrate X into three operating systems.

”

fully compatible with the original but will have operating-specific extensions and its own look and feel.

“DECWINDOWS is being integrated into all our operating systems,” explained Phil Auberg, DEC's VMS product marketing manager. DEC probably can rest assured that few other vendors are trying to integrate X into three operating systems. Currently, the VAX-STATION 8000 is the only place X11 is running under VMS. “Over the next several months, you can expect several updates,” said Auberg.

Now the sales pitches begin. Prepare for all the hardware vendors to tell you that their X11 has been optimized to be the fastest in the industry. Running on their hardware and operating system, it probably will be.

Building On X11

X is based on a client/server model, the W system, that was developed at Stan-

ford. The client requests graphics, and the server provides them. The server can be local or on a different type of CPU on the other side of the building; the user doesn't have to know. This allows applications to run on platforms where they can run best, rather than being restricted to the workstation.

The shipped data is converted into a protocol called X Wire, which is defined by MIT. It's optimized for 200 KB network transfer and any protocol (DECNET, TCP/IP or IPC) with a reliable byte duplex stream.

The X11 client application is made of several layers: The Xlib programming interface, which interfaces with MIT toolkits, which interface with high-level graphics (PHIGS, GKS, etc.), from which a look and feel can be developed. Basic dirty user interface extractions called widgets are provided in the toolkits. X Manager is a screen manipulator that allows you to lay out your own windows using a mouse.

X11's toolkit was lacking in X10; people had to write code directly to Xlib. This should spur the development of consistent user interfaces. X11 doesn't specify the look and feel of the user interface; it simply provides a set of tools with which to build one. The look and feel consists of how the graphics and icons align on the screen and how the toolkit gets called. (X10 also had an inconsistent user interface; different commands or different keys brought up different windows.)

DECWINDOWS

DEC already has developed its own toolkit extensions called DEC Toolkit that reportedly contains several ad-

No other application development software is quite this fast.



Sure, you expect speed. But not this much speed. Truth is, anyone who has ever developed applications is surprised by PROGRESS. Like the developers who gave it the highest satisfaction rating among the 4GL DBMSs recently surveyed by DATAPRO*:

Well, hold your horses.

Because now there's something even better: new PROGRESS V4. It's designed for building, modifying, and customizing database applications. It requires less code than other 4GLs,

it's crash-proof, and it's transparently portable across VAX/VMS, UNIX, XENIX, ULTRIX, MS-DOS, LANs, and CTOS/BTOS.

But now it's been enhanced with over 25 major new features, to give you even more speed, flexibility, and control.

For only \$95†, you can test drive a complete copy of PROGRESS V4. And if it's not as fast as we say it is, we'll refund your money. So call today.

And hang on tight.

Send \$95† for your PROGRESS V4 Test Drive.
Or call: Progress Software Corporation
(Formerly Data Language Corporation)
5 Oak Park
Bedford, MA 01730
1-800-FAST 4GL
(In Massachusetts,
call 617-275-4500)
FAX: 617-275-4595
Telex: 509965



PROGRESS[®]
FASTEST FROM START TO FINISH.

Offices in: Boston, San Francisco, Washington, D.C., Amsterdam, Brussels, Cologne, Copenhagen, Helsinki, London, Melbourne, Munich, Oslo, Paris, Sydney, Stockholm, Vienna, Zurich

*DATAPRO Reports on Software. DATAPRO 70 © 1986, 1987. DATAPRO RESEARCH CORPORATION †For international orders please call for shipping and handling information.

PROGRESS is a registered trademark of Progress Software Corporation, developers of advanced software technology for business and industry. The following are trademarks of the following companies: VAX, VMS and ULTRIX of Digital Equipment Corporation; UNIX of AT&T; MS-DOS and XENIX of Microsoft Corp.; CTOS of Convergent Technologies Corporation; BTOS of Unisys Corporation.

CIRCLE 154 ON READER CARD

vancements over MIT's. DECWINDOWS also will consist of a set of core applications (e.g., clocks, calendars, etc.) that can be tailored to a user's professional needs.

Like all the platform vendor's versions of X, DECWINDOWS will maintain 100 percent compatibility at the X server/X client level. Above that, levels of software will be added, including one that adds an interface that can be integrated into VMS or ULTRIX.

To ensure that DECWINDOWS will be an instant success, DEC has provided many third-party software vendors, mostly official cooperative marketing partners, with advanced versions of the DECWINDOWS toolkit code, or at least "... with all the information necessary to move applications into this window-based environment," states Auberg. That way, with its usual flourish, DEC will be able to announce a large number of

compliant software packages with its first version of DECWINDOWS.

Marketing Considerations

Although many pricing and marketing decisions haven't been made by DEC, it looks like a new ball game for software pricing. Your average VAXSTATION, for example, might have one window running VMS, another ULTRIX, and a third a Cray application. How can you set prices for that? Won't everyone suddenly be running everyone else's applications?

There probably will be no separate order code for the X extensions. It should come integrated with the operating system, so there will be "... no added cost to customers buying applications," according to Auberg. Some industry analysts are speculating that you eventually will have to buy operating systems separately.

Fielding a question about standard

screen interfaces and Apple's copyright protection lawsuits, Auberg said, "We've gone to great lengths to be certain that it's specific to Digital and that we're not plagiarizing any other work."

Although it was too early to have conclusive benchmarks, Auberg predicted that X's performance under VMS and ULTRIX "... will be roughly the same."

Other Extensions: Masscomp

The new 6000 computers, a family of real-time UNIX-based workstations and minicomputers from Masscomp of Westford, Massachusetts, were released running MIT's X11, but Masscomp is busily putting the finishing touches on its own high-level extensions for the X toolkit.

Masscomp accompanied its 6000 series announcement with the release of version 4 of the RTU operating system, a flavor of UNIX that's capable of running in either the System V or Berkeley 4.2 universes. Its X extension eventually will interface with both.

Masscomp, which also works actively with MIT, says that the latest release of the X Toolkit includes a significant contribution of Masscomp graphics software. According to Masscomp's Richard Carling, who helped design the current X Toolkit and public domain extensions to the previous toolkit, one of the company's major goals in enhancing the toolkit will be to provide a widget editor that simplifies the creation of complex user interfaces.

Masscomp's version, due at the end of the summer, is currently in external beta test, said Masscomp's Graphics Software Engineer Sam Black. The extensions are mainly performance extensions. Some of them are an extension that adds use of data tablets; user-shared rather than network-shared memory; and an X Feed Fill that allows users to fill arbitrary regions.

"Performance will vary, based on which graphics you have," explained Black, "and there are slight considera-

"IT MAKES PROCOMM LOOK LIKE AMATEURCOM."

If you talk to a DEC mainframe, no software emulates the VT220, VT100 or VT52 terminal more accurately or professionally than VTERM.*

Hot keys. Kermit. Automatic reformatting for spreadsheets and databases. VTERM has it all.

Why not join the 60,000 users of VTERM (many of whom moved up from Procomm). And try the DEC terminal emulation package that's in a totally different league.

FREE EVALUATION KIT.

Yes, send me a free time-limited, full-blown working copy of VTERM/220, which is mine to keep.

Name _____

Title _____

Company _____

Address _____

Telephone (____) _____

I am a user dealer . Mail to:

Coefficient Systems Corporation

611 Broadway, New York, New York 10012 (212) 777-6707

DP788P

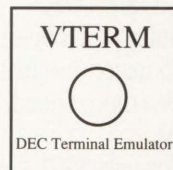

VTERM refers to VTERM/220, VTERM/4010, etc. products from Coefficient Systems Corporation. Procomm is a trademark of Datastorm Technologies, Inc.

Questions? Want faster action? Call (212) 777-6707, ext. 619.

CIRCLE 107 ON READER CARD

tions in terms of the number of processors."

X Terminals

Neither DEC nor Masscomp will admit to having plans to manufacture a terminal specifically designed to handle X protocols, but a handful of third-party companies already have begun to introduce X terminals.

GraphOn Corporation is offering an X graphics terminal that runs over an asynchronous line and uses the host's server. Visual Technology Inc. also has become involved, introducing an X terminal at COMDEX last May. A few others have developed X servers in graphics accelerator cards that have the ability to accept high-level X protocols.

According to Brian Croxon, senior vice president of new products at Visual Technology Inc., its X terminal "... is a full, local implementation of the server portion of the X system." In other words, the X server is located in software on the terminal and theoretically can communicate with any host applications running on the network.

The terminal has ports for Ethernet coaxial and ThinWire, and an auxiliary

asynchronous port. The terminal's Ethernet flexibility allows you to use TCP/IP and other communications protocols in a local area network.

The porting process pulls in the application running on the client portion. Network services, which reside between the server and client, also can be accessed from the terminal. "Because the original concept of X was to provide a device-independent protocol, we haven't deviated from that," Croxon stressed.

He said that Visual is working indirectly with MIT's X Consortium to stay X-adherent (the Ethernet connection is X11.2) and proprietary extensions due from all the consortium's platform vendors will run smoothly. "We've left it open to add extensions when they're agreed upon," he explained. At press time, Visual hadn't decided which terminals the X terminal might emulate,

but Croxon said, "We'll do a classic terminal emulation as is standard in UNIX terminals."

Scores of other terminal companies inevitably will develop X terminals along the lines of Visual's or GraphOn's. Future versions could be tuned to specific environments and do X, Microsoft Windows and Presentation Manager. "The opportunity is one that is going to expand the market in the areas of terminals and PCs," predicts Croxon.

The market will expand in many directions. The magic will occur when all the X extensions communicate transparently across a multivendor network, with every vendor using another's implementations.

ARTICLE INTEREST QUOTIENT
Circle On Reader Card
High 521 Medium 522 Low 523

Companies Mentioned In This Article

Digital Equipment Corp.
146 Main St.
Maynard, MA 01754
(617) 897-5111
CIRCLE 524 ON READER CARD

GraphOn Corp.
1901 Bascom Ave.
Campbell, CA 95008
(408) 371-8500
CIRCLE 525 ON READER CARD

Masscomp
One Technology Way
Westford, MA 01886
(800) 451-1824
CIRCLE 526 ON READER CARD

Visual Technology Inc.
1703 Middlesex St.
Lowell, MA 01851
(617) 459-4903
CIRCLE 527 ON READER CARD

"IT MAKES C-C-CROSSTALK SEEM T-T-TONGUE-TIED."

If you're talking to a DEC mainframe, no communication software emulates the VT220, VT100 or VT52 terminal more accurately, easily, or eloquently than VTERM.*

Hot keys. Kermit. Automatic reformatting for spreadsheets and databases. VTERM has it all.

Why not join the 60,000 users of VTERM (many of whom moved up from Crosstalk). And try the DEC terminal emulation package that has everyone in the business buzzing.

FREE EVALUATION KIT.

Yes, send me a free time-limited, full-blown working copy of VTERM/220, which is mine to keep.

Name _____

Title _____

Company _____

Address _____

Telephone (____) _____

I am a user dealer . Mail to:

Coefficient Systems Corporation

611 Broadway, New York, New York 10012 (212) 777-6707

DP788C

VTERM* refers to VTERM/220, VTERM/4010, etc. products from Coefficient Systems Corporation.
Crosstalk is a trademark of Digital Communications Associates, Inc.

Questions? Want faster action? Call (212) 777-6707, ext. 619.

CIRCLE 294 ON READER CARD

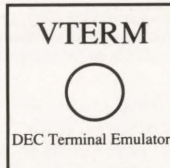

IN A NOISY WORLD...

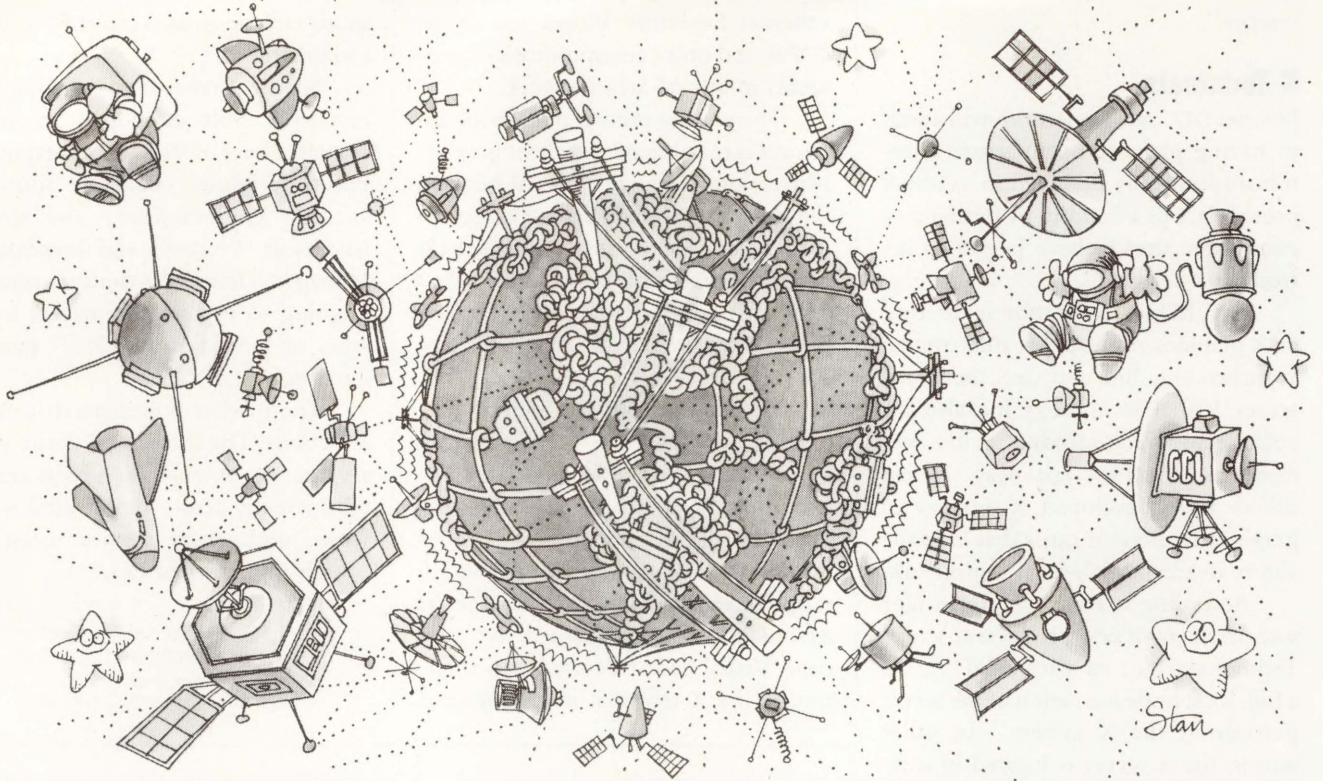

BLAST IS THE UNCHALLENGED LEADER IN COMMUNICATIONS SOFTWARE

PERFORMANCE LOSS WITH INCREASING NOISE

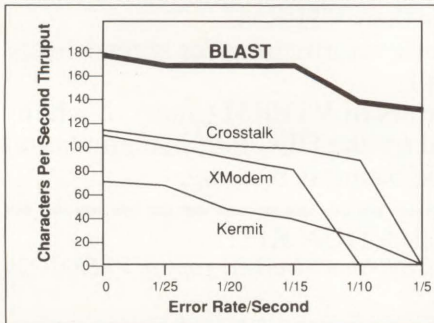

Noise simulation tests run with a 30K binary spreadsheet file at 1200 baud between IBM-PC's, using BLAST II, rev. 8.1. Comparable or better results on VAX and other environments.

Most communications software performs well under ideal conditions. But in the *real* world of noisy communications circuits and satellite-routed phone calls, there's only one consistent performance leader—BLAST.

The secret is **BL**ocked **AS**ynchronous **T**ransmission, BLAST's protected-pipelining protocol that won't slow down to a snail's pace, drop data or disconnect in adverse conditions. Noisy phone lines... satellites... PBX switches... X.25 packet network delays—your valuable data BLASTs through it all.

Link PCs, Macs, Minis & Mainframes

Only BLAST guarantees you fast, 100% error-free file transfer among micros, minis and mainframes running under 30 different operating systems. No matter *what* systems you need to connect, BLAST software links them all. Connect hundreds of sites at down-to-earth prices—and let BLAST's speed cut your phone charges, too.

And the new BLAST II expands upon this rugged power with a streamlined user interface, VT-100/220 emulation, superior data compression, auto-dialing and all the other "state-of-the-art" features you'd expect. Plus, you get **BlastScript**, a powerful English-like programming language that lets you quickly create custom menu-driven applications on multiple systems. Easily set up remote polling, data collection, order entry and other powerful applications.

The choice of the FORTUNE 500

When Bankers' Trust, Blue Cross, Exxon, Nabisco and many other FORTUNE 500 companies chose communications software for their financial data transfer operations, they chose BLAST to cut through the noise. Shouldn't *you* choose BLAST too? Give us a call today.

1-800-24-BLAST

Any computer with BLAST can talk to any other computer with BLAST:

IBM	VM/CMS or MVS/TSO
DEC	VAX/VMS; PDP/R SX; RT-11
DATA GENERAL	RDOS; AOS; AOS/VS
WANG	VS
PRIME	PRIMOS
HEWLETT-PACKARD	3000/MPE; 1000/RTE
HARRIS	VOS
UNISYS	BTOS, CTOS, UNIX
IBM-PC & PS/2	MS-DOS
APPLE	Macintosh
UNIX/XENIX	AT&T; Altos; NCR; Sun; Tandem; HP; VAX & mVAX; SCO Xenix; etc.

Many others available; please inquire.

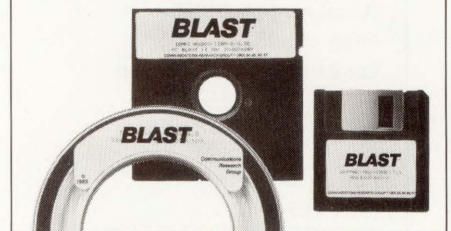

BLAST®

Communications Research Group

5615 Corporate Boulevard • Baton Rouge, LA 70808 • (504) 923-0888
© Copyright 1988, Communications Research Group, Inc.
Crosstalk is a registered trademark of Digital Communications Associates, Inc.

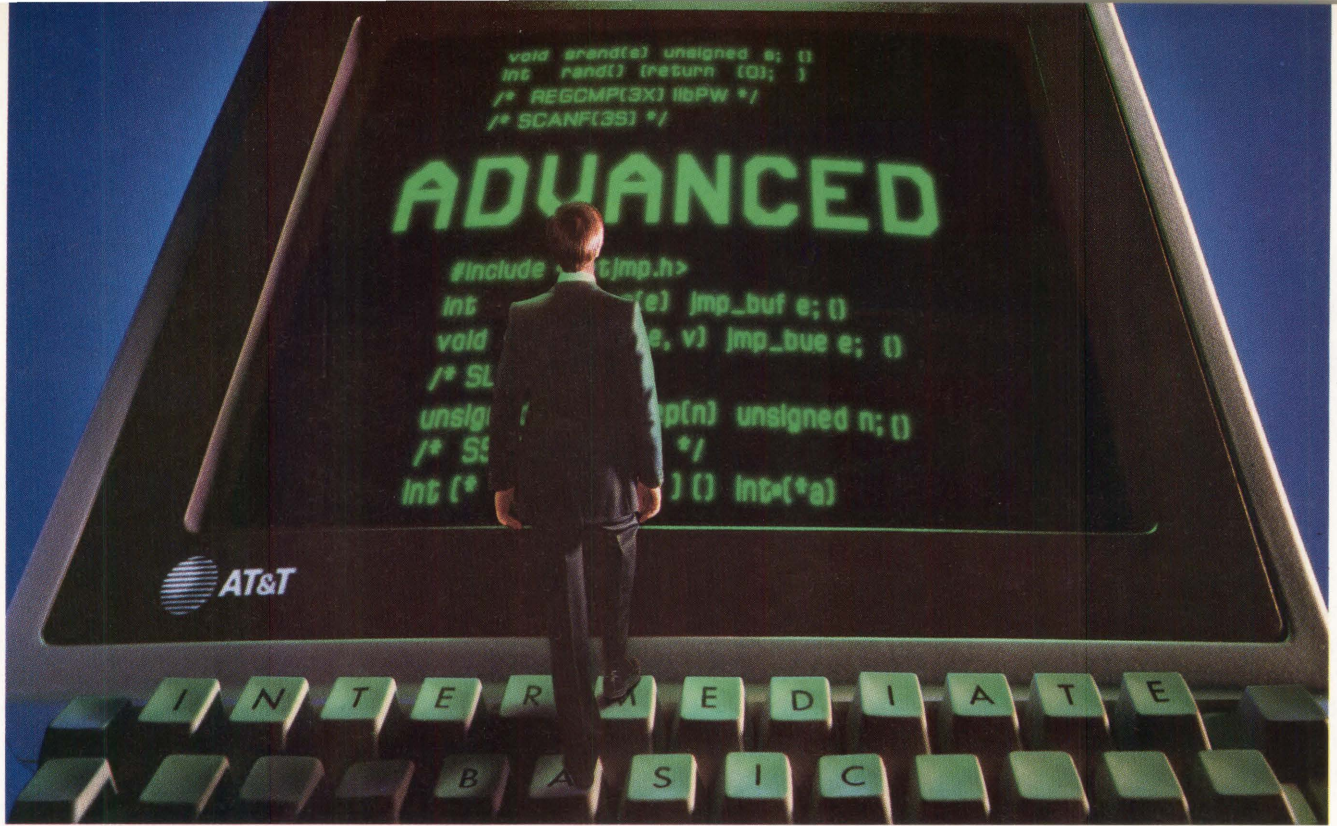

The more advanced your training needs, the more you need the experts who created the UNIX[®] System.

You've gone beyond the basics, and now you need *serious* training developed by AT&T Bell Laboratories.

We're the people who created the UNIX System. We teach the most current and advanced levels of System V Release 3, including courses on Internals.

We also teach—independent of a machine's architecture—Generic System Administration and Generic Device Drivers.

Additionally, we offer Shell Programming and C Languages, including C++.

You can study at our training centers nationwide with AT&T's most skilled computer science

instructors, all of whom have hands-on experience as developers and programmers.

Or if you prefer, our instructors will come right to your location. And we even offer a comprehensive range of economical videotape instruction.

If you're ready to step up to advanced UNIX System training, AT&T is ready for you. Call or write now for details.

AT&T COMPUTER TRAINING
Come right to the source.
1 800 247-1212, ext. 863.

Or send in the coupon below.

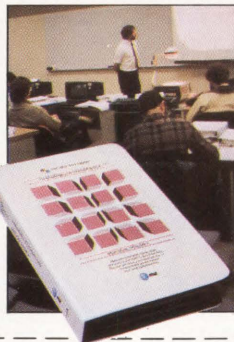

Registrar, AT&T Training, P.O. Box 45038, Jacksonville, FL 32232-9974

YES! I'd like advanced level computer training right from the source. Please rush me more information about:

- Classroom Training, including course descriptions and schedules for the Advanced UNIX[®] System and programming languages.
- Videotape Training in the UNIX System, C Language, and Shell Programming Language.

Name (Please print) _____

Title _____ Phone () _____

Company _____

Address _____

City _____ State _____ Zip _____

DET07018

© 1988 AT&T



AT&T

The right choice.

David W. Bynon

Capacity Planning And System Design, Part 2

In "Capacity Planning And System Design, Part 1"

(May 1988), I suggested that larger, more accessible systems can be designed using DEC's Ethernet-based VAXCLUSTER technology, the Local Area VAXCLUSTER (LAVC). Let's now look at the capabilities and configurations of MICROVAX clusters.

After DEC's success with clustering large VAX systems and avid customer

interest, it made sense to push the same technology down to the MICROVAX line. DEC had done its homework; VAXCLUSTER technology is a logical extension of DEC's layered network design. A VAXCLUSTER is a software system built on resource managers and drivers. Further, cluster drivers are divided into port and class drivers. This strategy facilitates device independence. In other words, it doesn't matter what medium you use to connect your cluster members (VAX computers); simply write a

port driver to support it.

Big VAXCLUSTER systems use DEC's Cluster Interconnect (CI), which is a high-speed coaxial network. Each node has an I/O processor (CI780, CI750, etc.) that connects two communication channels (A and B) to a central hub called a Star Coupler. Although this same technology could have been implemented on MICROVAX systems, the cost would have been prohibitive.

DEC's solution was to use a communication medium that has been available all along, Ethernet. Like the Cluster Interconnect, an Ethernet controller is a high-speed communication processor that uses a coaxial wire as its medium. Small differences exist between the two systems: the CI has a 70-megabit bandwidth compared to Ethernet's 10, and an Ethernet controller has only one channel.

By using an Ethernet as a VAXCLUSTER communication channel medium, Local Area VAXCLUSTER systems forego the expensive hardware components, such as the Star Coupler, CI and HSC. Furthermore, multiple Local Area VAXCLUSTERS can use the same Ethernet; each is identified by a unique cluster number and protected by a cluster password. Each LAVC consists of two to 26 nodes, two of which can be boot nodes. A boot node is any VAX (except 11/725 and 11/730) or MICROVAX system that provides local storage services.

Clusters were born to share resources and build larger, more capable computer systems. As a side benefit, clusters provide greater accessibility to

T A B L E .

Number of concurrent users:	80
Types of users:	Programmers — 7 Managers — 21 Draftsmen — 2 Clerical staff — 32 Data entry personnel — 13 Accountants — 5
Major applications:	Word processing, electronic mail, database management, drafting, program development, spreadsheets, corporate accounting
Software Packages:	WordPerfect Office, Oracle, SAS, VAXnotes, Auto CAD, FORTRAN compiler, 20/20, and Down to Earth Accounting
Terminals:	78
Printers:	5
Computer environment:	Office building with computer room Five floors
Future expansion:	Ten data entry personnel (12 mo.) One accountant (6 mo.) Two programmers (18 mo.) One manager (12 mo.) Six clerical (12 mo.)

Requirements to perform a variety of applications.

data and computing resources. Most of these qualities are also characteristic of LAVC systems.

Just as diskless VAX systems boot from HSC controllers, diskless MICROVAX systems may boot from a boot node. To facilitate redundancy of resources, two boot nodes are used. Unlike HSC-based systems, LAVC disks can't be dual ported, and thus data availability isn't always guaranteed; i.e., if one of the two boot nodes goes down, the storage maintained by that system will be unavailable to the cluster. In a large Local Area VAXCLUSTER of say eight or more nodes, a second boot node is used to relieve the heavy disk I/O activity that would plague a single boot node.

Capacity Planning

The most important member of the LAVC is the boot node. This system must be capable of handling its own compute and I/O load and the disk I/O requests of the other cluster members. If your cluster's disk I/O demand of the boot node is light to moderate, the system will respond as if several additional users were on the system; CPU demand will increase. If the demand on the boot node's disks is heavy, interactive user response on the boot node will be degraded severely.

Remember that the I/O demand on a system will depend on that system's computing abilities and the throughput capability of its disk system. For instance, a heavy disk I/O load for a MICROVAX II with two RD54s would be a drop in the bucket for a MICROVAX 3000 with a pair of RA82s. In some configurations, you may find it beneficial to implement a boot node with no interactive users. The boot node then acts like an HSC, providing storage services for the cluster. In this way, the boot node can be tuned specifically for disk I/O, and superior performance would be achieved.

The other cluster members, which may be diskless, are used primarily as compute servers. Although it's possible to use diskless systems, designing this type of system will permit less than

Why this publication and more than 1,300 others let us go over their books once a year.

Some publications, we're sorry to say, keep their readers undercover. They steadfastly refuse to let BPA (Business Publications Audit of Circulation, Inc.) or any other independent, not-for-profit organization audit their circulation records.

On the other hand, over 1,300 publications (like this one) belong to BPA. Once a year, BPA auditors examine and verify the accuracy of our circulation records.

The audit makes sure you are who we say you are. The information helps advertisers to determine if they are saying the right thing to the right people in the right place.

It also helps somebody else important: you. Because the more a publication and its advertisers know about you, the better they can provide you with articles and advertisements that meet your information needs.

BPA. For readers it stands for meaningful information. For advertisers it stands for meaningful readers. Business Publications Audit of Circulation, Inc. 360 Park Ave. So., New York, NY 10010.



desirable performance characteristics. Page and swap file activity should remain on the local system; at a minimum, non-boot members should have a disk for page and swap file use. Also, there's no reason that non-boot members can't have local storage for user files.

Capacity planning for CPU performance and memory requirements should be performed on a node-by-node basis, as if each VAX in the cluster were a standalone system. Note that clustering consumes both CPU and memory resources for CPU-to-CPU communications. A good average is five percent to 10 percent of the CPU and about 500 pages of memory. The more cluster members you have, the greater the CPU demand from cluster overhead will be.

Storage capacity planning is computed on a cluster-wide basis. Remember, all storage resources are available to

each member of the cluster. Try to evenly distribute disk storage, and therefore disk I/O load, where possible. In the case of some systems, such as VAXSTATIONS and small MICROVAX 2000 systems, a completely diskless computer is practical and economical. Also, your application might demand little from the disk I/O system, so you might want a single boot node with all of the cluster's storage. These are the factors to investigate when planning a LAVC.

System Design

The Table shows the requirements for a sample system to perform a variety of applications. The LAVC excels at this challenge. Individual processors may be dedicated to the various types of applications, allowing the system manager to tune and tailor each system separately.

First, decide which processors can

be used to accommodate the workload. For example, programmers and draftsmen should have machines dedicated to their specialized needs. The draftsmen, for instance, may require a color VAXSTATION 2000 or a VAXSTATION II/GPX. With only single-user access, these VAXSTATIONS could be completely diskless.

The programmers, who tend to consume every available resource, should be segregated to their own system or VAXSTATIONS. A MICROVAX II, with a local disk for paging and swapping, would accommodate this task. A local disk could be used for program storage, as compiling and linking of programs is disk intensive.

The accounting department, with five accountants, lends itself to a tailored environment. A MICROVAX II or MICROVAX 2000 will work equally well; for the price performance difference, the

Hirschmann

Hirschmann introduces the Active Star Coupler

The most advanced approach to Ethernet LAN expansion.

Richard Hirschmann, a world leader in fiber optic technology, now offers superior network expansion capabilities. The Active Star Coupler.

The Active Star combines the advantages of fiber optics with traditional copper Ethernets. The result: one remarkable modular package that allows you to extend your Ethernet backbone 4.5 Km from DTE to DTE, while maintaining up to two 10 base 5 and 10 base 2 copper cabling segments — on any individual link.

Active Star utilizes all popular fiber sizes allowing up to 3,000 meters without repeaters.

In addition, its modular design enables you to intermix transmission media cards without affecting the larger network — eliminating the down-time that usually occurs with link expansion and diagnostics.

To learn more about the Hirschmann Active Star Coupler, call us at 1-800-225-0524. Find out what our advances in technology can do for your advances in business.

RICHARD HIRSCHMANN OF AMERICA, INC.

Industrial Row, P.O. Box 229, Riverdale, New Jersey 07457
Tel: (201) 835-5002 Fax: (201) 835-8354

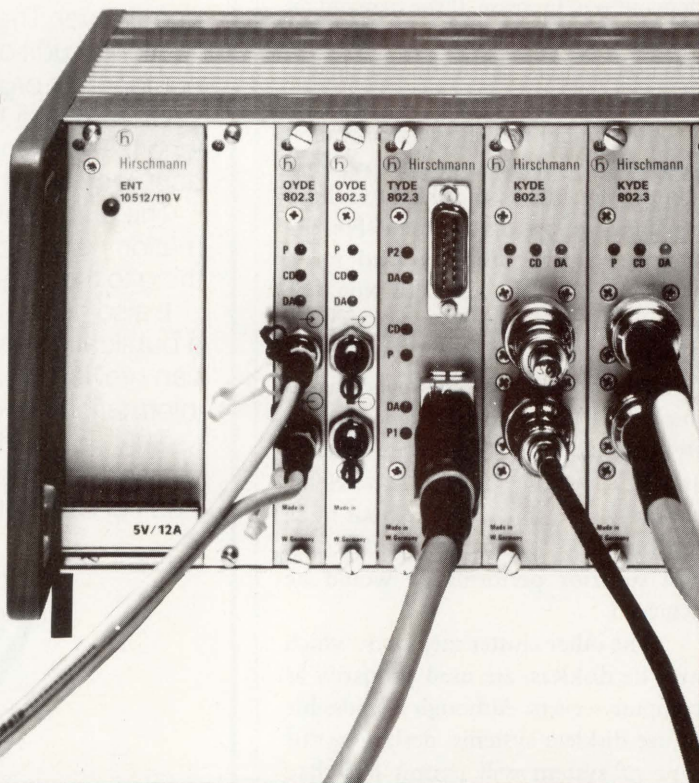

CIRCLE 212 ON READER CARD

MICROVAX 2000 would be the better choice. Because multiple users will be accessing this system, a local page and swap file disk should be used, such as an RD53 or RD53 equal. An expansion box wouldn't be required.

The data entry personnel will be performing transactions on corporate databases. This type of activity requires a dedicated system. Assuming growth, a MICROVAX 2000 wouldn't be suited to the I/O requirements of data entry and transaction processing. A MICROVAX II would fill the current requirement, but would accommodate only moderate growth. A MICROVAX 3000 configuration or several MICROVAX 2000s should be considered for this job. I recommend a MICROVAX 3000 system, as the storage for the databases then could be local, affording the system the best possible performance.

The most prevalent applications,

word processing and electronic mail, will be used by everyone in the corporation, primarily the managers and clerical staff. Additionally, the managers will be using the spreadsheet and analysis programs to generate reports from the databases created by the data entry people. Because this system will have the heaviest I/O demand, it should be your boot node. With the current number of potential interactive users (up to 53), consider the largest MICROVAX or even a large VAX system. A VAXBI system, such as an 8350 or 8530, would provide superior I/O bandwidth, so one of the smaller VAXBI systems might fit your needs.

Terminal access to these systems is through LAT terminal servers. The terminal servers facilitate ease of wiring, multiple terminal sessions and connection to cluster nodes other than the primary one; i.e., if the accounting

MICROVAX 2000 goes down, the accountants can connect to the boot node. Using the DECSERVER 100/200s, 11 servers would be needed. Other equipment manufacturers, such as Emulex and Xyplex, also build LAT-based servers.

The majority of the cluster's storage will reside on the boot node, and you should have the cluster's backup medium. Don't underestimate the need of a cluster for high-speed backup. When you back up a cluster member's local storage across the Ethernet, you will be using the resources of two systems. The faster the backup, the better.

The most important thing to remember about designing a Local Area VAXCLUSTER system is that there's no right way to do it. Use your creativity to configure the system that's best for your application. ■

FIBER OPTIC MULTIPLEXER

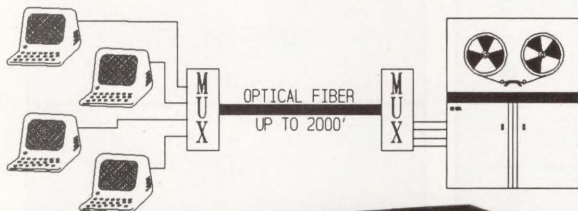

Our fiber optic mux represents a low cost alternative to a network. Connect up to 8 asynchronous RS232 terminals- at baud rates from DC to 19.2K baud- almost as simply as turning on the power! No software to install. Built in loop diagnostics ensure data integrity. The full duplex fiber optic cable is lightning and noise immune as well as data secure.

CVD SYSTEMS

PENN CENTRE PLAZA QUAKERTOWN PA 18951 (215)536-2104

Unlock Programmer Productivity

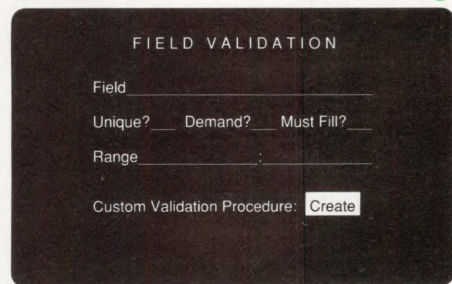

With System 1032 Application Facility

System 1032/AF automatically generates most of your application code from menu selections. Yet you can add custom procedures wherever you need something special.

CompuServe

Data Technologies
Tel: (617) 661-9440

CIRCLE 222 ON READER CARD

CIRCLE 111 ON READER CARD

TCP/IP For Network Services

One of the problems with networks is that there are

many different protocols and network types. The hardware choices are confusing enough, but software protocol suites that run over the various types of network hardware solutions can boggle the mind. Ethernet, for instance, boasts a vast number of protocol suites such as DDCMP, LAT, MOP, XNS, SCS, TCP/IP, VRP, NRP and a slew of other three-letter acronyms for various protocols that will solve the customer's problems.

Within the scheme of protocols, however, some rear their ugly heads, no matter how hard the industry tries to put them down or get rid of them. Consider one such suite, Transmission Control Protocol/Internet Protocol (TCP/IP).

Every other vendor of networks claims that its protocol is better and that TCP/IP is going away. Some point to the decisions made by the Department of Defense to migrate eventually to internationally recognized and standardized communications hardware and protocols, obviating the need for TCP/IP and eventually replacing it. Some view TCP/IP as a workhorse needing to be put to pasture.

Then there are the zealots, who think that the only communications protocol suite for use in the world is TCP/IP, and all others are fluff. These folks are dangerous, because they're vocal about TCP/IP.

Somewhere in the middle are those who don't know what to do with TCP/IP or, worse, don't understand its significance to networks. Unfortunately, these individuals are usually the managers of such diverse camps of at-

titudes and must make decisions on whether to use TCP/IP on a project or not. The answer is a clear, concise and to-the-point maybe.

Development

TCP/IP came about because of the various networking needs of the government. Developed at Stanford University by Vint Cerf and his associates, TCP/IP was created to satisfy the

need to interconnect various projects including computer networks and allow for the addition of dissimilar machines to the networks in a systematic, standardized manner. Although the smaller defense projects may not have warranted the use of TCP/IP for project aspects, edicts from various DOD sections forced many government contractors and in-house developed projects to use the suite to conform with DOD requirements.

FIGURE .

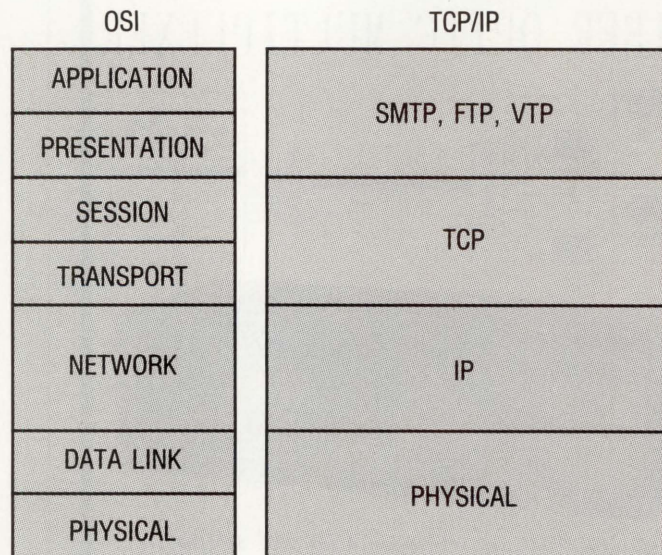

The OSI standard (left) is based on a seven-layer reference model that defines the functions required in a communications transmission and the relationship between them. In a TCP/IP configuration (right), the Transmission Control Protocol (TCP) component corresponds to OSI Layer 4 (Transport), while the Internet Protocol (IP) component, which is responsible for packet routing between networks, corresponds to Layer 3 (Network). The physical networks themselves, implemented as point-to-point (TTY Driver, HDLC) or bus-oriented (Ethernet) hardware, correspond to Layers 1 (Physical) and 2 (Data Link).

The TCP/IP suite isn't a single protocol. Rather, it's a four-layer communications architecture that provides some reasonable network features, including end-to-end communications, unreliable communications line fault handling, packet sequencing, internetwork routing and specialized functions unique to DOD communications needs such as standardized message priorities. The bottom two layers, collectively referred to as network services, (see Figure), provide for communication to network hardware. Network hardware used in the various networks throughout the DOD typically reflects the use of Federal Information Processing Standard (FIPS)-compliant network hardware (such as IEEE 802 series of LANs and other technologies including X.25).

The layer above the network services layer is known as the IP, or Internetwork Routing Protocol, layer. It's responsible for providing a datagram

service that routes data packets between dissimilar network architectures (such as between Ethernet and, say, X.25).

IP has a few interesting qualities, one of which is the issue of data reliability. As a datagram service, IP doesn't guarantee delivery of data; data concurrency, sequencing and delivery guarantee are the job of the Transmission Control Protocol, or TCP. TCP provides for error control, retransmission, packet sequencing and many other capabilities. It's very complex and provides most of the features of the connection to other applications on other systems.

To properly understand TCP/IP, it's important to know that it's not Open Systems Interconnect (OSI) compliant in implementation (although some argue that there are substantial similarities), and it's a unique network architecture that provides traditional network services in a way that can be overhead intensive in some implementations.

Most networks provide a connection mechanism to get from point A to point B. Other networks worry about how to get from node A on network X to node B on network Y. If a program wishes to send information from itself on node A to another node on the same network, TCP will provide the packet sequencing, error control and other services that are required to allow reliable end-to-end communications.

This doesn't mean that IP is required. In fact, some implementations of TCP connect directly to the network services layer and bypass IP. However, if a program on node A on an Ethernet wishes to connect to a destination program on node B on an X.25 network, an internet routing function is necessary to get data packets sent properly between the two dissimilar network services. IP would take the packet from TCP, pass it through a gateway that would provide conversion services and send it to the IP

DON'T BUY A VAX SPREADSHEET

Without trying GRAPHIC OUTLOOK from Stone Mountain Computing.

If you are looking for LOTUS-like capability on the VAX, try GRAPHIC OUTLOOK. It's powerful. It's useable. And it's affordable.

GRAPHIC OUTLOOK provides

- A LOTUS command mode that makes it as easy to operate as 1-2-3.
- Automatic transfer of worksheets to and from 1-2-3 (versions 1A and 2) and Symphony.
- High-quality business graphics on most popular graphics terminals, plotters, and laser printers.
- 2-user, 6-user licenses, a lease plan and right-to-copy discounts for clustered VAXes.
- Probably more capability than you've ever seen in a spreadsheet program.

Call about our demonstration package. GRAPHIC OUTLOOK. Tomorrow's VAX spreadsheet program that's available now.



Stone Mountain Computing
P.O. Box 1369
Goleta, CA 93116
(805) 964-9101

VAX is a registered trademark of Digital Equipment Corporation.
LOTUS and 1-2-3 are registered trademarks of Lotus Development Corporation

CIRCLE 248 ON READER CARD

Unlock M.I.S. Backlogs

January 18, 1988

8:00	2:00
9:00	3:00
10:00	4:00
11:00	5:00
12:00	6:00
1:00	7:00

Do: _____
Call: _____

Calendar Select Add Delete Month Exit

With System 1032 Application Facility

One keystroke builds a standard application from any System 1032 database you indicate. You then extend this prototype into a full-fledged system by filling in specification menus.

CompuServe
Data Technologies
Tel: (617) 661-9440

CIRCLE 112 ON READER CARD

2.5 Gigabytes VAX Backup

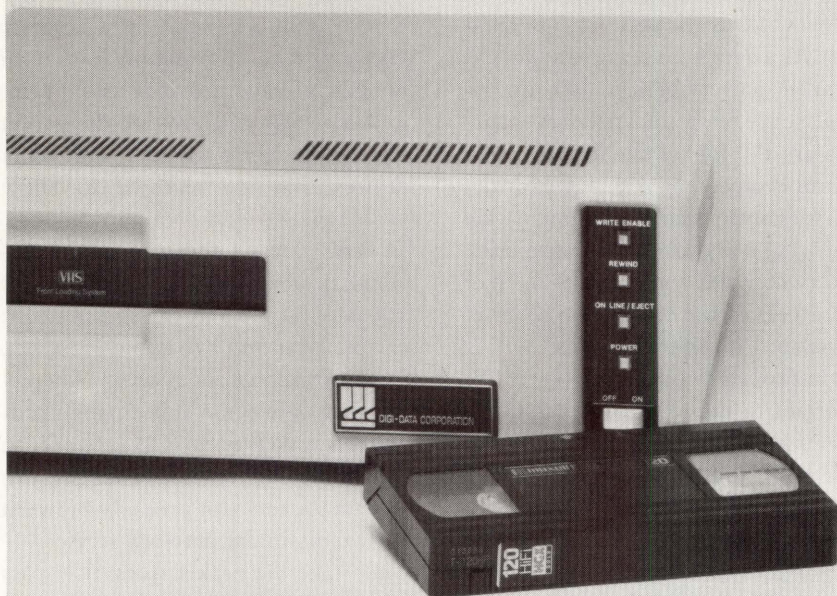

Gigastore works with the standard VMS, DCL Backup Command and all Qualifiers or standard Unix Dump/Restore Command and all Arguments. It also provides DEC tape emulation for general purpose use.

Utilizing true read-after-write coupled with very powerful error correction, GIGASTORE™ gives you an unsurpassed error rate of 1 in 10^{23} bits. In addition, you get a high speed search capability not available in most 9-track drives and the convenience of a T-120 VHS cartridge. An IBM PC interface is also available.

Call Digi-Data, an organization with a 25 year history of manufacturing quality tape drives, at (301) 498-0200.

™GIGASTORE is a trademark of Digi-Data Corporation.



DIGI-DATA CORPORATION
8580 Dorsey Run Road
Jessup, MD 20794-9990
(301) 498-0200
Telex 87-580

• ... First In Value

In Europe contact: Digi-Data Ltd. • Unit 4 • Kings Grove • Maidenhead, Berkshire
England SL6 4DP • Telephone No. 0628 29555/6 • Telex 847720

CIRCLE 184 ON READER CARD

ATTENTION VENDORS

The *DEC PROFESSIONAL* magazine will consider DEC-specific hardware and software products for review. We do not endorse or guarantee any products reviewed or discussed.

For further information contact:

The Editorial Department, Professional Press,
921 Bethlehem Pike, Spring House, PA 19477.

layer at the remote node for delivery to the remote TCP layer and, subsequently, the destination program.

Connection Examples

For example, Program A on node ALPHA wishes to connect to program B on node BETA on the same network. Program A sends a data packet to TCP with the proper destination address. TCP encapsulates the data with the proper header and checksums in accordance with the services requested by the program and passes the TCP packet to the IP layer. IP determines, from network directory information, that the remote node is on the same network as itself and simply passes the packet through to the network services layer for local network routing and delivery.

In the case of different networks, here's what happens when Program A on node ALPHA on network X wishes to connect to program B on node BETA on network Y. Data is handled as above, but IP determines that the destination isn't on the local network. As a result, the IP layer in node ALPHA determines the best route to get to the remote node and sends the TCP packet to the next IP node in the path to get to the remote. IP doesn't care to which program the source wants to connect; it cares about the node to which it sends the packets.

IP nodes in the path from node ALPHA to node BETA examine the packet to determine the destination and forward the packet to the proper IP until it reaches the destination network IP. IP determines that the node is on its local network, and the packet is handed to the network services layer for the network on which BETA resides for delivery to node BETA.

After the packet is received at the final destination IP, it's passed up to the TCP layer, which breaks out the packet header to figure out which program on the destination node is to receive the data. First, however, the packet header is examined carefully to ensure that it has arrived in the proper sequence and that there are no special handling issues that need to be serviced. After TCP is

satisfied that everything is reasonable, the data is delivered to the destination program.

But, there are some implementation issues that make all of this complex. Because TCP and IP allow many service options such as message priority, security classification, data segmentation at the TCP level, packet segmentation at the IP level and other issues with which some network architectures, such as DECNET, need not concern themselves, there can be overhead associated with packet processing. As a result, TCP/IP performance varies from network hardware to network hardware as well as from machine implementation to machine implementation.

Now let's look at some of the specifics. One of the base problems that TCP was built to address is connecting from a specific program, node and network to a remote program that might not be on the same network as the

originator. A method of addressing nodes needed to be developed that identified a particular program on a particular node in a particular network.

One solution is to develop hard addresses for all entities on a particular network. Although this solves the problem, it's inflexible and doesn't provide an upwardly-flexible network architecture.

Another problem is that some networks have their own proprietary addressing scheme that must be considered, as TCP/IP is above the local network addressing scheme mechanisms in the network architecture and will need to use the local mechanism on packet delivery. To solve the problem, TCP/IP uses a three-layer addressing mechanism that allows for delivery of packets across dissimilar network architectures.

Connection Specifics

Each program (called a PROCESS in TCP) has a unique one-up address on

each machine. That unique local program address is combined with a particular node address to form a port. The port address is combined with the local network address, forming a socket. There can be many sockets on a TCP/IP network, but each one identifies a specific application on a specific node on a specific network. Through this mechanism, IP will get the packets to the proper node, and TCP will deliver the packet to the proper program on that node. Some nodes provide a standard process type (such as type 23 for remote logins) that are known to other network entities and that provide certain standard services. Through this mechanism, TCP provides a multiplexing capability for the efficient use of the network resource.

As with any network, two sockets must have a mechanism for connecting to each other. TCP provides this in various ways. One of the more common ways connections are established is via

Introducing ...

TPTool

A Whole New Breed

TPTool is the practical, inexpensive alternative to traditional word processing on VAX/VMS.

- ◆ Extensive built-in printer support, and customizable to virtually any printer
- ◆ Unmatched price/performance
- ◆ 80+% of traditional word processing features at a fraction of the price
- ◆ Priced from \$345 to \$1295 per CPU
- ◆ Free on-line demo available

Another fine software product from:

 **GrayMatter**
Software & Consulting

(206) 281-8800

CIRCLE 278 ON READER CARD

Unlock VAX Resources

System 1032/Application Facility
AVAILABLE APPLICATIONS

- 1 - Sales Report Application
- 2 - Graph Sales Report
- 3 - Payroll
- 4 - Mailing list maintenance
- 5 - VMS
- 6 - Mail
- 7 - TPU Editor

With System 1032 Application Facility

System 1032/AF integrates everything on your VAX: VMS services, 4GL, existing 3GL modules. Integrate at the menu level or invisibly weave everything together inside an application.

CompuServe

Data Technologies
Tel: (617) 661-9440

CIRCLE 113 ON READER CARD

an ACTIVE/PASSIVE network OPEN. A PASSIVE OPEN is when a receptive socket declares itself to be open and available for incoming connections; this typically would be the mode used by something like a database server.

It may be set up in various ways.

ferred between them. TCP provides several mechanisms for data transfer; the two most popular are segmented data transfer and PUSH mode. Segmented data transfer allows TCP to send user data in chunks across the network. TCP can send the data in the most efficient

“
TCP provides the essential network connection and the data transfer features that a user needs to connect with a particular program on a remote system.
”

For instance, the PASSIVE OPEN can be *fully specified*, meaning that the socket issuing the PASSIVE OPEN tells the network which socket can connect to it, including security levels allowed and other related details.

In the *unspecified* PASSIVE open, the socket accepts any connection request from any remote socket provided the remote system requesting connection meets prescribed security and other criteria. In both types of network OPENS, the socket opening the network also can declare timeout values for all data received from the originator of the connection. This allows for the expeditious handling of data, provides a means by which old messages are handled in a reasonable fashion and processes correctly messages requiring special handling (in terms of time).

Another type of OPEN is the ACTIVE OPEN. Unlike the PASSIVE OPEN, the ACTIVE OPEN seeks a connection to a particular socket. An ACTIVE OPEN will be successful only if there's a cooperating and corresponding PASSIVE OPEN or other ACTIVE OPEN from the destination socket.

Data Transfer

After a connection has been established between two sockets, data can be trans-

ferred between them. TCP provides several mechanisms for data transfer; the two most popular are segmented data transfer and PUSH mode. Segmented data transfer allows TCP to send user data in chunks across the network. TCP can send the data in the most efficient manner for the network being used. Even if the user has transferred 25 blocks of user data to TCP, TCP may not send it all at once, opting to segment the data to provide optimal flow of data on the network.

Although this technique is great for data flow issues and network congestion issues, it can be troublesome for transfers in which the data needs to get to the remote system immediately. In such cases, the user can specify the PUSH flag. It forces TCP to send whatever has been passed from the user to TCP right away with no consideration for optimal flow control. Or, the user can specify the urgency of the data being transferred to keep the remote system on its toes.

The amount of data allowed to be sent from one socket to another is a function of the network and programs involved. Because TCP was developed with multiple network architectures in mind, it allows some level of link negotiation on connection and data transfer that provides for maximum buffer sizes (somewhat dynamically) and maximum buffer allocation.

To ensure that everything gets to its destination in the proper order, TCP provides packet sequencing services and error detection functions, using a 16-bit checksum in the TCP header area. TCP presumes the IP layer to be unreliable

and, therefore, contains a 96-bit pseudo-header in front of the TCP packet header that includes the source address, destination address, protocol being used and segment size. Through the pseudo-header, TCP protects itself from having the IP deliver the packet to the wrong place (or not at all) by misinterpreting TCP header fields. The checksum in the TCP header also includes the pseudoheader bits to ensure that everything is clean when it hits the remote side.

Link Shut Off

After the connection is established and all data has been transferred, the link can be shut down via user request. This is the clean way. It's possible that the link also can be aborted abruptly because of link drop or some catastrophic failure of the network or socket-to-socket linkage. TCP provides mechanisms to handle both situations. Issuing a CLOSE primitive tells the TCP that the user is finished with the network link and closes down the link by sending all remaining data in local buffers and notifying the remote socket that the sending user wishes to CLOSE the link.

The remote TCP socket notifies the user that a CLOSE has been issued. The user then can send any remaining data and issue a CLOSE to the sender. When the sender receives the CLOSE acknowledgement from the receiver, it sends a TERMINATE to the user and notifies the remote TCP that a TERMINATE has been issued. The remote TCP socket sends a TERMINATE to the remote user, and the link is closed completely.

If a network link abort occurs, for whatever reason, the ABORT primitive is sent to the remote TCP which tells the remote user that a TERMINATE has occurred. No more data of any kind is transmitted on the link and the link is closed immediately on both sides. A link termination of the ABORT kind isn't desirable, as data may be lost, and other

integrity issues may be involved.

The TCP need not be connected to an IP, although that's frequently the case. TCP provides the essential network connection and the data transfer features that a user needs to connect with a particular program on a remote system. Some companies use TCP as the protocol of choice when setting up simple direct-connect network connections (where the remote node is hard wired to the originating node) or when performing tasks such as downline system loading. In any case, TCP is a powerful and full-featured protocol that provides reasonable network services for user data.

Many times, however, just getting the data from one socket to another can involve the connection to various types of network technologies. A TCP packet coming in from an asynchronous link may need to be routed onto an Ethernet to reach its ultimate destination. Because of the need to connect and properly

route data through to its proper network and destination socket, the IP layer was developed.

IP Description

A datagram service, IP provides rudimentary internetwork routing services without regard to the destination program, TCP formats, error control, packet sequencing, etc. It gets the packet to the right network and, eventually, to the right node. Further, IP allows for expedited routing of packets that need to get to a destination quicker than other routine packets.

In many respects, with the exception of routing priority, IP functionality is similar to Ethernet packet handling. If a packet arrives that's damaged (there's an IP checksum), the packet is discarded. What's in the data field of the packet is of no interest to IP. IP could be sending a TCP packet or some other protocol for all it cares. As long as the

proper SEND (user sending to the network) primitive fields have been filled in, IP will send the packet on its way.

When the packet reaches the remote node, and the checksum figures out that it's OK, IP sends the packet to TCP (or whatever the receptor protocol is) via a DELIVER directive. If the packet gets trashed in the process of being delivered, so be it. If the packets arrive out of sequence, that's not IP's problem. If a packet is missing, IP doesn't care. IP gets the data packet (usually a TCP packet) from point A on network X to point B on network Y.

To provide the internetwork routing function, IP makes use of special nodes called gateways. A gateway, in IP terms, is a machine that allows two dissimilar networks to be connected to each other. The two networks can, but don't have to be, the same technology, as the IP operated above the type of technology being used and concerns

Low Cost 9-Track Tape Subsystems for MicroVAX and PDP/11 Q-Bus Computers

**The solution to your
micro / mainframe
communications problem
is available today!**

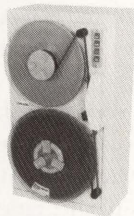

Qualstar's new 1/2 inch 9-track MINISTREAMER™ brings full ANSI data interchange capability to your DEC Micro VAX or PDP/11 system. Now you can freely exchange data files with virtually any other computer using 9-track tape.

Available in both 6250 and 1600 BPI versions, the MINISTREAMER weighs in at only 38 pounds and uses less desk space than an ordinary sheet of paper, yet provides full 9-track capability at an affordable price. Up to 250 megabytes of data (depending on format) can be stored on a standard 10 1/2" reel of tape, thus making the MINISTREAMER a highly-reliable answer to your backup requirements as well.

The MINISTREAMER tape subsystem is hardware compatible with the Micro VAX I, Micro VAX II, LSI-11, 11/2, 11/23, 11/53, 11/73 and 11/83.

Tape subsystem includes desk-top streaming tape drive, Q-Bus coupler card, dust-cover and full documentation. Qualstar tape subsystems are also available for IBM PC/XT/AT, Macintosh, SCSI, and VME bus computers.

Discover the many advantages 9-track tape has over other Micro/Mainframe links.

Call us today!

Micro VAX, PDP/11, Q-Bus, and DEC are trademarks of Digital Equipment Corporation.

QUALSTAR®

9621 Irondale Avenue
Chatsworth, CA 91311
Telephone: (818) 882-5822

CIRCLE 260 ON READER CARD

Application Development Seminars

July 13 Toronto, Canada
July 15 Montreal, Canada
July 27 Seattle, WA
July 29 Salt Lake City, UT
Aug. 10 Los Angeles, CA
Aug. 12 Orange Cnty, CA

9 a.m. to Noon

See our 4GL-based application development environment in action at a free morning seminar. Call our Seminar Coordinator to reserve your spot.

CompuServe

Data Technologies
Tel: (617) 661-9440

CIRCLE 286 ON READER CARD

itself only with virtual connection functions.

There can be a need to segment large messages from the upper software layers into sizes that are applicable to the remote network's allowances. To do this, IP will segment large messages into proper sized chunks (such as when going from 1,500-byte Ethernet packets to 128-byte X.25 packets) for the destination network and reassemble them at the remote destination IP layer before delivery to the user.

If a packet gets destroyed in the segmented message and the remote IP detects the packet loss, the entire segment is killed off by the remote IP. TCP would detect that a segment is missing and request a retransmission from the remote TCP for any missing packets. TCP has the option of forcing IP not to segment packets, but this usually isn't implemented, as it can cause routing problems where differing network technologies are concerned.

IP also provides for proper security classification of packets being sent to a remote site. If an intermediary gateway or network isn't at least the same security level as the transmitted packet, the packet won't be sent through that network. As a result, some strange routing of data can occur sometimes, as IP must contend with the problems of expeditious routing and security-oriented routing.

IP has some different terminology than that used in a network. In many networks, the concept of a *hop* is the routing of a data packet through a node on its way to its final destination point. In IP, a hop is when a data packet goes through a gateway to another network. Therefore, it's possible that a packet may wander through various nodes in a local network before it actually gets to the remote network gateway, depending on variables.

If the packet doesn't incur a route through a gateway, in IP terms, it hasn't incurred a hop. If it transverses through

two gateways, it would have incurred two hops on its path to the final destination.

Thus, TCP and IP aren't the same and can be implemented independent of each other for separate uses. However, they usually are both included in offerings from various vendors.

In any network architecture, the protocols and transmission methods aren't enough. Users frequently want and need utilities that implement the protocols in the network architecture to allow file transfer, program communication, virtual terminal support and electronic mail. Most TCP/IP implementations are the same, and a few standard applications exist.

Utilities

File transfer facilities usually are provided for by a File Transfer Protocol (FTP). It's a simple-featured file-moving utility that allows a record-oriented (one record at a time) transfer, a block transfer (which moves chunks of a file) or an image transfer (which doesn't look at the file contents). FTP knows about EBCDIC and ASCII (also NVT-ASCII) and can provide some rudimentary conversion facilities before a transfer begins.

As file systems are very complex, and the need for file transfer between systems is growing, FTP has evolved in some cases to special implementations that know how to convert specific file formats between certain types of machine architectures. This conversion facility isn't within the defined scope of FTP, but some vendors include the conversion features anyway. To transfer a file, the user invokes the host FTP utility; specifies file name, type (if necessary) and remote destination; and sends it off.

One interesting feature on some FTP implementations is the recovery facility. In the case of network failure, any transfers in process usually will have to be restarted from scratch. If the file is being transferred with FTP in block mode, the transfer can be resumed at a later time by specifying which block was the last transmitted. FTP then con-

tinues to send the file as if nothing had happened. This feature isn't available on all FTP implementations and has some host and remote system software considerations involved with it, but it's a useful feature to have when transferring very large files.

Another popular utility is TELNET. It's a virtual terminal facility that allows a user to connect to a remote system as if his terminal were hard wired to that remote system. Virtual terminals can emulate a wide variety of terminals, impractical on larger, complex networks. TELNET provides a basic protocol-handling facility and a negotiation facility that allows for the inclusion of different types of terminal protocols and signaling mechanisms.

Another popular utility is the Simple Mail Transfer Protocol (SMTP). It provides a mechanism whereby a user can specify a destination address (or addresses, if to more than one remote user), a particular path to follow (if desired) and a message. Like other electronic mail systems, SMTP provides for return receipts, forwarding of mail and other similar features. But, it isn't intuitive, and the routing issues can get strange. Yet, it's a useful utility and heavily used in the defense area.

Some TCP/IP vendors have made a living providing their wares to defense contractors and UNIX/ULTRIX shops that need to connect and communicate with their compatriots supporting TCP/IP. The way that vendors have implemented TCP and IP varies greatly, meaning that features and performance vary. Some vendors, such as Excelan, implement the protocol suite in a controller card, offloading the host from running TCP and IP programs and utilities while providing the necessary connectivity. This makes the overall system more cost-effective and less bogged down in the network mire.

Other companies, such as Wollongong, implement TCP/IP in software on the host. This degrades the host system, sometimes severely, but can function as

a true IP node, allowing simultaneous connection to various network technologies.

Each implementation has its benefits and drawbacks. The best one for a particular system depends on cost factors, system loading expectations and the number of different kinds of networks to which a site may be connected. Some vendors have introduced TCP/IP routers that allow IP services to different types of networks by connecting the networks through a dedicated IP router (sometimes referred to as an IMP) and allowing TCP messages to be created by a particular network protocol, translated into TCP and sent to a destination node.

The source node thinks that it's talking to a machine running the same protocol on the same network. In reality, the packet has been translated and set to the destination node on either the same or another network. Such routing and translation trickery is becoming

more prevalent in environments where TCP and other types of networking software exist.

TCP/IP's Future

In the quest to TCP/IP or not, the bottom line is, how long can it last? A few years ago, I would have said that TCP/IP would last a company for some years to come. Now that the Department of Defense will no longer require it, opting to go with OSI, it's not a safe bet for all sites. There are enough TCP sites installed that it would be foolish and expensive to convert them to something else.

The number of networked machines to appear by 1995 will far eclipse the number currently installed, making protocols such as TCP/IP a minority. I bet that TCP/IP will be around for a while to support current systems. As those systems move over to OSI, however, fewer nodes will be seen run-

ning TCP or IP.

What would I do if I had to buy today? Buy TCP/IP, because it works and it's now. It will serve for the next two to four years and give the OSI packages some time to mature.

A nice side benefit is that the OSI transport service and TCP's capabilities are very similar, as are the OSI network layer routing service and the IP services. Further, TCP/IP prescribes standardized network hardware, so OSI-compliant hardware is a given in many TCP/IP environments, allowing a migration path to OSI at a future date.

TCP/IP is a serious protocol suite. It provides reasonable network services for most applications and is extensible, well documented and fairly straightforward to implement. It is capable of connecting dissimilar machines on dissimilar networks into one network. — *Bill Hancock is an independent systems and network consultant in Arlington, Texas.*

POWERFUL TEAMMATES

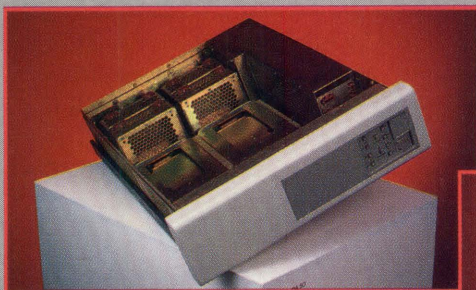

**5.25" DISK STORAGE ENCLOSURE
DA 50**

- Mounting for four 5.25" Peripherals on slide plates
- Easy Installation and Removal of Peripherals
- Chassis Slides with full extension
- 50 Watt Power Supply for each 5.25" Peripheral
- Control Console with Write Protect/Ready functions
- Disk Access Indicator
- Audible and Visible Thermal Protection Alarm
- I/O Panel with 2 C size cutouts...bridges allow for 4 B size cutouts
- Remote Input Connector for power control by remote device



**10.50" SYSTEM ENCLOSURE
DA 523**

- Cardcage with 12 Slot "CD" Q-Bus Backplane
- Mounting for five 5.25" Peripherals on slide plates
- Vertical Cardcage for easy module access
- 500 and 50 Watt Continuous Power Supplies
- Control Console with Write Protect/Ready functions
- Audible and Visible Thermal Protection Alarm

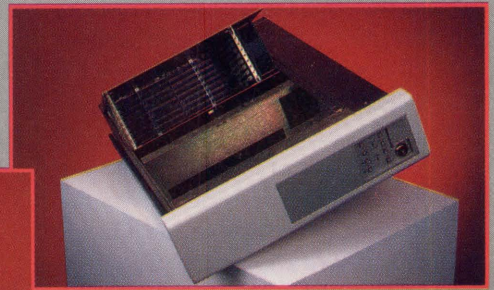

**5.25" SYSTEM ENCLOSURE
DA 23**

- Cardcage with 8 Slot "CD" or "Q22" Backplane
- Mounting for two 5.25" Peripherals on slide plates
- Tilt-Up and Locking Cardcage for easy module access
- 350 Watt Continuous Power Supply
- Control Console with Write Protect/Ready functions
- Audible and Visible Thermal Protection Alarm
- Drive Access Indicator
- Power Supply Voltage Monitoring and Indicator
- I.E.C. Multi-Voltage AC
- Remote Output Connector

TRIM INDUSTRIES



11949 Sherman Road, North Hollywood, CA 91605
Phone: 818-983-1833, 800-272-3557 in CA 800-423-2024 outside CA
0438 TWX: 910 499 4745

TRIM INDUSTRIES LIMITED



2-6 Giltway, Giltbrook, Nottingham NG16 2GN England
Phone: (0602) 385485
FAX: (0602) 389973 Telex: 378317



CLUSTER CHRONICLES

Dave Mallery

Hardware Connection Considerations

Author's note: I must start this report with an erratum. In May, I

said that you could put a short stub on your ThinWire, keeping the tee connector behind a wall plate. Wrong! The Ethernet specification prohibits stubs. The wall plate configuration is only valid for a single stub coming from a DEMPR port. Thanks to the many readers who pointed this out.

I want to address a series of major problems we encountered connecting good hardware to a good network and seemingly breaking both.

Several major Ethernet products use the XNS protocol. There's an imbedded addressing scheme within this protocol. It's easy to choose the defaults (or for the vendor to choose them) and end up with conflicts on your net. It seemed that each time we added another product, the same thing would happen.

I'll describe our experiences with the Logcraft 386ware as an example. We've used Logcraft Cardware for several years now as an add-in board in our 750's UNIBUS. We were eager to try the Ethernet box in our new cluster. One of the main reasons was that the Cardware was only available on the 750, and the users had no control over which node they were entering.

After a short trial, we decided that the only way to really evaluate it was to convert our entire group of users to the new environment. As the song goes, "Ain't nothing like the real thing. ..."

The first problem we encountered was with the LAVC. Because the LAVC overhead makes huge demands on the DEQNA, the Logcraft software was timing out for lack of service. This

LAVC-specific problem was fixed almost immediately by the vendor.

Converting existing Logcraft users was fairly easy. The vendor supplies a

“

Another problem to overcome was the conversion of the Rainbow users to using print spoolers rather than their prized attached printers.

”

utility that converts the data from the previous disk format to the new format required by 386ware.

Converting our last few Rainbow holdouts proved more difficult. Most of the difficulty was in getting the files off the Rainbow and into the VAX intact. Wholesale copying of files can be accomplished with KERMIT. Then, on the

VAX side, we copied groups of files into the 386ware disks using Logcraft's utility.

Another problem to overcome was the conversion of the Rainbow users to using print spoolers rather than their prized attached printers. Now, their print output is in a single file, spool.lis, that's created by the procedure. When they leave 386ware, they can direct it to the local laser of their choice with a print command. Print file output is specified in the start-up procedure executed by the individual 386ware user. We developed a simple DCL menu for all users. They invoke it by giving a standard command. We've supplied the command procedure on ARIS.

The performance of the 386 is legendary. We have a large Lotus 1-2-3 model of our business that we've developed over the last five years. It is 400 down by AR wide. On the Rainbow, it took almost a minute to recalculate. Now on 386ware, the recalc time is less than four seconds. This time will vary slightly with the current load on the 386 drivers.



386ware features a shareable 386 CPU with floating point accelerator and memory. It's served over the Ethernet. Files are kept on any VAX node. Printing is done via normal VMS queues. The floppy is available to any user.

PROGRAM.

```

$ VER = F$VERIFY(0)
$!
$! 386WARE.COM : Setup and run IBM/PC Emulation for Logcraft 386WARE
$!
$!
$ SAVE_DEFAULT = F$ENVIRONMENT("DEFAULT")
$ ON WARNING THEN GOTO ABEND_PROC
$ ON CONTROL_Y THEN GOTO END_PROC
$!
$DISPLAY_MENU:
$!
$! Display options menu.
$!
$ TYPE SY$INPUT

                Logiccraft 386WARE Main Menu

1. Connect to Logcraft 386WARE.
2. Convert old CARDWARE disk to 386WARE.
3. Create new (empty) 386WARE disk.

$ INQUIRE OK "Enter selection (Q to quit) [1] "
$ IF OK .EQS. "" THEN OK = 1
$ IF OK .EQS. "Q" THEN GOTO END_PROC
$!
$ IF OK .EQ. 1 THEN CALL CONNECT_386WARE
$ IF OK .EQ. 2 THEN CALL CONVERT_DISK
$ IF OK .EQ. 3 THEN CALL CREATE_DISK
$!
$ GOTO DISPLAY_MENU
$!
$END_PROC:
$ EXECUTE RESET
$ SET TERM/INQUIRE
$ SET DEF 'SAVE_DEFAULT'
$ IF VER THEN SET VERIFY
$ EXIT
$!
$ABEND_PROC:
$ SET DEF 'SAVE_DEFAULT'
$ TYPE SY$INPUT

Please report the above error to the MIS dept.

$ IF VER THEN SET VERIFY
$ EXIT
$!
$CONNECT_386WARE: SUBROUTINE
$START_CONNECT:
$!
$! Connect to 386WARE.
$!
$ IF F$SEARCH("SY$LOGIN:386WARE.TMP") .NES. "" THEN -
DELETE SY$LOGIN:386WARE.TMP:*
$!
$ SEARCH_DIR = F$TRNLOG("SY$LOGIN")
$ SEARCH_DIR = SEARCH_DIR - "]" + ".386WARE]"
$!
$ OPEN/WRITE OUTPUT_FILE SY$LOGIN:386WARE.TMP
$ WRITE OUTPUT_FILE "$ SET VERIFY
$ WRITE OUTPUT_FILE "$ SET TERM/DEVICE=VT200/EIGHTBIT"
$ WRITE OUTPUT_FILE "$ SET BROADCAST=NONE"
$ WRITE OUTPUT_FILE "$ DEFINE/USER SY$INPUT SY$COMMAND"
$ WRITE OUTPUT_FILE "$ SRV SPOOL.LIS/NOQ/FLA/PR=LST1,-"
$ WRITE OUTPUT_FILE " SPOOL2.LIS/NOQ/PR=LST2,-"
$ WRITE OUTPUT_FILE " SY$386WARE:D386C/READ_ONLY/SHARE, -"
$ WRITE OUTPUT_FILE " SY$386WARE:NEWLOTUS/READ_ONLY/SHARE, -"
$ DOS_FILE_FOUND = "N"

```

```

$ WRITE SY$OUTPUT " "
$ WRITE SY$OUTPUT " "
$!
$386WARE_SEARCH:
$ DOS_FILE = F$SEARCH("'"SEARCH_DIR'".DOS",1)
$ IF DOS_FILE .EQS. "" THEN GOTO FINISH
$!
$ WRITE OUTPUT_FILE " '"DOS_FILE'/SHARE, -"
$ IF .NOT. DOS_FILE_FOUND THEN -
WRITE SY$OUTPUT "The following .DOS files will be used :
$ WRITE SY$OUTPUT " '"DOS_FILE'"
$ DOS_FILE_FOUND = "Y"
$ GOTO 386WARE_SEARCH
$!
$FINISH:
$ WRITE SY$OUTPUT " "
$ WRITE OUTPUT_FILE " /MEM=704/SER=MORDOR/HOT=26/CTRL_S/CTRL_Q/BRE"
$!/SERVER=MORDOR/CTRL_S/CTRL_Q/NOBREAK/CACHE/MEM=704/HOT=26/NOFLUSH"
$ WRITE OUTPUT_FILE "$ SET BROADCAST=ALL"
$ WRITE OUTPUT_FILE "$ SET NOVERIFY
$ CLOSE OUTPUT_FILE
$!
$ IF DOS_FILE_FOUND THEN GOTO BOOT_PC
$ TYPE SY$INPUT

```

I could not find any .DOS files in your directory. If you already have a .DOS virtual disk file, then it should reside in either of the following locations:

```

$ WRITE SY$OUTPUT " '"SEARCH_DIR'"
$ WRITE SY$OUTPUT " "
$ WRITE SY$OUTPUT " "
$ INQUIRE OK "Would you like to create a virtual disk now? (Y or N) [N]"
$ IF OK .EQS. "" THEN OK = "N"
$ IF .NOT. OK THEN GOTO END_CONNECT
$ CALL CREATE_DISK
$ GOTO END_CONNECT
$!
$BOOT_PC:
$ @SY$LOGIN:386WARE.TMP
$!
$END_CONNECT:
$ ENDSUBROUTINE
$!
$CONVERT_DISK: SUBROUTINE
$CONVERT_DISK_1:
$!
$! Convert an old CARDWARE disk to 386WARE.
$!
$ INQUIRE DISK_NAME "Enter the name of the disk file to convert"
$ IF F$SEARCH (DISK_NAME) .EQS. "" THEN CALL INVALID_FILE
$ IF F$SEARCH (DISK_NAME) .EQS. "" THEN GOTO CONVERT_DISK_1
$ DOSDIR 'DISK_NAME'
$ ENDSUBROUTINE
$!
$INVALID_FILE: SUBROUTINE
$ WRITE SY$OUTPUT " "
$ WRITE SY$OUTPUT "The file you specified does not exist!"
$ WRITE SY$OUTPUT " "
$ ENDSUBROUTINE
$!
$CREATE_DISK: SUBROUTINE
$!
$! Create a virtual disk
$!
$ SEARCH_DIR = F$TRNLOG("SY$LOGIN")
$ SEARCH_DIR = SEARCH_DIR - "]" + ".386WARE]"
$!
$ IF F$SEARCH("SY$LOGIN:386WARE.DIR") .EQS. "" THEN -
CREATE/DIR 'SEARCH_DIR'
$ INQUIRE DISK_NAME "Enter the name you wish to give to your disk "
$ DOSMAKE 'SEARCH_DIR' 'DISK_NAME' 5000
$ ENDSUBROUTINE

```

There are several options to further enhance that performance. There are drivers that can be put into Lotus 1-2-3 that accelerate the graphic performance of the product, both on regular terminals and on VAXSTATIONS.

We totally have converted both our previous Cardware users as well as our standalone Rainbow users to 386ware. We decided to capitalize on the investment by offering Lotus classes to the employees. These are well attended and suddenly, new Lotus applications are appearing throughout the company. It looks like we'll have to upgrade from the four- to the eight-user license soon. It's surprising, however, how many casual users can be supported by a four-user machine.

Now, back to the problems. As soon as we put the Logcraft onto the same Ethernet as the Xyplex, both XNSs stopped working. To fix it, we had to have the folks from Logcraft dial into the system and change around some XNS IDs.

As an aside, a few weeks later, we found ourselves with another XNS product, Mobius from FEL Computing. This is an Ethernet-based PC interface that can serve files to the PC from the VAX while also providing VT220-style terminal emulation. Fortunately, they

have prepackaged about six variations of the XNS, and we chose one that didn't conflict with the other two implementations.

Cluster progress report: We've decided to bring our Ethernet to California. We'll start by putting Xyplex gateways in front of a pair of Emulex modems. On the Spring House, Pennsylvania, end, we'll simply connect the gateway into our DELNI. The gateways intelligently will filter out only the California-bound traffic. On the Pasadena end, we'll connect the gateway to another DELNI.

Then we'll use a pair of cluster controllers and also connect into the VAX node as well. We're planning local dial-in lines for ARIS access in southern California and simply will connect the modems directly to a cluster controller. The limiting factor will be the 14.4 bandwidth of the phone line. The line is due soon. Stay tuned.

Part of the magic of this line is the cost. I found a carrier, Williams Telecommunications Group, that had pulled fiber through a network of defunct gas pipelines through the West and offered inexpensive coast-to-coast links. My line from Spring House to Pasadena on a one-year contract tallied \$1,100 per month. That's cheap. ■

Companies Mentioned In This Article

FEL Computing
10 Main St.
Williamsville, VT 05362
(802) 348-7171
CIRCLE 575 ON READER CARD

Logcraft
22 Cotton Rd.
Nashua, NH 03063
(603) 880-0300
CIRCLE 571 ON READER CARD

Lotus Development Corp.
55 Cambridge Pkwy.
Cambridge, MA 02142
(617) 577-8500
CIRCLE 572 ON READER CARD

Williams Telecommunications Group
1 Williams Center
PO Box 21348
Tulsa, OK 74121
(918) 588-3210
CIRCLE 573 ON READER CARD

Xyplex Inc.
100 Domino Dr.
Concord, MA 01742
(617) 371-1400
CIRCLE 574 ON READER CARD



**COLT
SOFTWARE
TECHNOLOGIES**

SOLUTIONS TO THE SOFTWARE PUZZLE

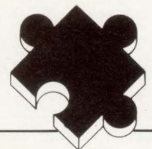

- Retail Management with POS
- General Accounting
- Distribution
- Manufacturing
- Job Costing Const.
- Service and Call Dispatch Management
- Real Estate Management
- Mailing List
- Custom Systems

EXECUDESK - Executive/Salesman Organizer
Corporate Event Calendar, Personal Calendar/Scheduler,
Equipment Scheduler, Personal Expense Organizer, Master
Appointment Scheduler, Message and Reminder System,
Business Calculator.

EASYPAGE - Desk Top Publisher for the Multi User
VAX on most ASCII terminals. Provides high quality style-
based print. Pre-designed document style with flexibility.
Intergrates text and graphics. Document preview on a
graphics terminal. Fully integrated into A-to-Z (not required).

Authorized Distributor
DIGITAL BUSINESS SYSTEMS, INC.
201-542-7600 DEALER INQUIRIES WELCOME

ExecuDesk: Calendar, Messages, Calculator, Phonebook, Expense, Setup, E...
PERSONAL SCHEDULER
FEBRUARY
SU MO TU WE TH FR SA
1 2 3 4 5 6
7 8 9 10 11 12 13
14 15 16 17 18 19 20
21 22 23 24 25 26 27
28 29

CHANGE
1. Company Name: COLT SOFTWARE TECHNOLOGIES
2. Phone: 201-542-7600 3. Ext: 0234
4. Contact Name: JOHN DOE
5. Addr Line 1: P.O. BOX
6. Addr Line 2: 4-IN STR
7. City: NEW YORK
8. Zip: 12345-6789
9. Zip: 12345-6789
10. Comment: SPECIAL DOWN

ent Time is: 1:11
1. Send Reminder to Whom: JIMMYE
2. Reminder Date: 2-25-85
3. Reminder Time: 8:00
4. Message: Don't forget meetings at 7:00

ANY CHANGE? Y ANY CHANGE? Y

EXECUDESK allows windowing
to and from all modules.

CIRCLE 299 ON READER CARD

When Used Isn't Good Enough

Sometimes NEW is too much and USED isn't good enough. Our REMANUFACTURED computer equipment fills this void and offers the best of both worlds. All system components are dynamically tested and inspected for wear before shipping. Included is a six-month warranty.

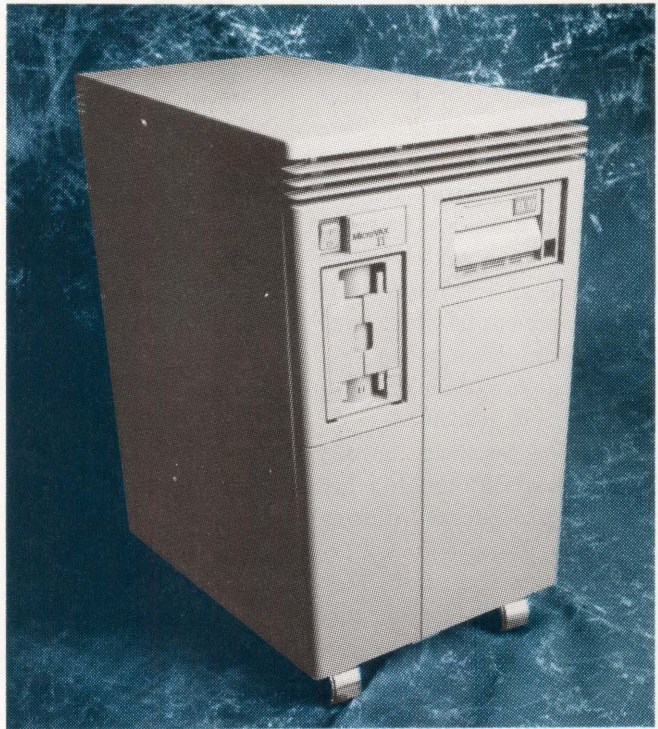

Quality Equipment at Reasonable Prices

MICROVAX II

- Remanufactured DEC* MICROVAX II (3MB, BA23) available for only \$17,500
- Remanufactured RD53, TK50 Subsystems \$2,000 (with MVII purchase)
- Two user MICROVMS license \$500
- Free video monitor and mouse with each full system purchase.

VAX 8600XA-AE

- Remanufactured DEC* VAX 8600 XA-AE VMS license, twelve-month warranty \$365,000

Call toll-free 1-800-722-4777 today and cash in with savings on quality equipment.

Specialists in Depot Repair of Circuit Boards



RESTOR
a Cincinnati Bell company

7880 Foundation Drive
Florence, Kentucky 41042

CIRCLE 156 ON READER CARD

A

DCL DIALOGUE

Kevin G. Barkes

Errors, Non-Errors And Errata

For the most part, DCL is a friendly environment in which to develop utilities. The command language interpreter excels in providing programmers with information about the environment in which their procedures execute. Even when DCL responds atypically to a command, simple workarounds are available.

Consider, for instance, the SET DEFAULT command. Although I had forsaken DCL procedures offering enhanced set default capabilities, I decided to create a procedure that would emulate the MS-DOS change directory (CD) command.

The challenge was to recover from a SET DEFAULT to an invalid directory. Normally after issuing a DCL command, you can determine the success of the execution by examining the value of \$\$SEVERITY.

Totally successful command executions place the value 1 in \$\$SEVERITY; commands which neither completely succeed nor fail (i.e., they terminate with an informational status) insert the integer 3 in \$\$SEVERITY.

I built the .COM file and was chagrined to discover it wasn't behaving properly; it appeared as if the value in \$\$SEVERITY was incorrect.

A test proved this assumption:

```
$ set def [-.qrk] (non-existent directory)
$ sho def
DISK1:[USERFILES.TEST.QRK]
%DCL-I-INVDEF, DISK1:[USERFILES.TEST.QRK] does not exist
$ write sys$output $severity
1
```

DCL's text of the severity level, "-I-", for informational, was correct.

Nonetheless, the value placed in \$\$SEVERITY was 1, indicating normal, successful completion, rather than 3, successful completion with informational.

An interesting discovery, it didn't solve my problem. The workaround was fairly simple, even though it made the procedure longer:

```
$! CD.COM
$ IF P1 .EQS. ""
  THEN GOTO B
$ IF F$PARSE(P1) .NES. ""
  THEN GOTO A
$ WRITE SYS$OUTPUT
  "'P1' is an invalid default."
$ EXIT
$ A:
$ SET DEFAULT 'P1'
$ B:
$ WRITE SYS$OUTPUT
  F$ENV("DEFAULT")
$ EXIT
```

There are only two active lines in the procedure. The first line after the

comment tests to see if P1 is blank; i.e., no default was specified. If the parameter is empty, the procedure branches to B: and displays the current default using the F\$ENVIRONMENT lexical function.

If P1 contains text, the lexical function F\$PARSE is used to test whether the specified default exists. If it doesn't, F\$PARSE returns the null string, and the procedure's error message is displayed. Otherwise, the procedure executes the set default command and displays the new default.

Using F\$PARSE has another benefit: Give it a bad default or incorrect directory specification, and it simply returns the null string. No error messages are generated, unlike SET and SHOW DEFAULT, which scream DCL bloody murder when bad data is passed to

PROGRAM.

```
$! REC.COM
$ SET NOON
$ IF P1 .EQS. "" THEN GOTO ZIPPO
$ IF F$SEARCH(P1) .EQS. "" THEN GOTO ZIPPO
$ ASSIGN/USER REC.TMP SYS$OUTPUT
$ APPEND/LOG 'P1' NLAO:
$ OPEN/READ IN REC.TMP
$ READ IN REC
$ START = F$LOCATE("(" , REC) + 1
$ VAL2 = F$LOCATE(" records" , REC)
$ REC_COUNT == F$INT(F$EXT(START , VAL2 - START , REC))
$ CLOSE IN
$ DELETE/NOCONFIRM/NOLOG REC.TMP;*
$ EXIT
$ ZIPPO:
$ REC_COUNT == -1
$ EXIT
```

them. This eliminates the need for using SET MESSAGE to inhibit unwanted error messages.

I need only CD in a set default utility, and I've included it here to show some of the ways to get around limita-

can be justified, because it performs a valid function.

The results of REC.COM's operation are placed in the global symbol REC_COUNT. The symbol contains either the number of records in the file

“

REC.COM is inefficient and kludgy, but it works and its existence can be justified, because it performs a valid function.

”

tions in DCL. (Please don't send me any more, unless you've developed a telepathic interface to the keyboard.)

Stupid DCL Tricks

This was the short title of my presentation at the Cincinnati DECUS Symposium in May, although the seminar officially was titled "Utility Development in DCL." This column's being written about a month prior to the event and (apologies to David Letterman) I'm busily putting the finishing touches on the DCL Lexicalthrillcam and trying to find a 50-foot platform from which to drop a DCL Dictionary.

"Stupid DCL Tricks" also will be an irregular feature of this column, and you're invited to send in examples of contorted uses of DCL to achieve otherwise practical goals.

There are two rules: The procedures must perform some useful function and must represent the simplest DCL solution to the problem.

For example, take REC.COM (see Program), which returns the number of records contained in a file.

There's no direct way to obtain this information from DCL; the F\$FILE_ATTRIBUTES lexical can provide scads of data, but a file's record count isn't one of them. REC.COM is inefficient and kludgy, but it works and its existence

or the value -1, if the procedure failed for some reason. Additional error-checking can be added to bulletproof the procedure, but for our purposes it's sufficient.

@REC FILENAME invokes the procedure. If the specified file can't be found or is an invalid file name, REC_COUNT is set to -1. Otherwise, use the APPEND/LOG command to append the file to the null device, and use the ASSIGN/USER to redirect the output of the file to REC.TMP. Next, read in REC.TMP and, using several lexicals, extract the number of records appended to the null file. The value is assigned to REC_COUNT, and the procedure performs clean-up prior to exit. About as elegant as an oiled duck, it works.

The VAX and Rainbow echomail areas on FidoNet have been humming along, and users have uploaded lots of useful utilities here at the SYS\$OUTPUT bulletin board system. First-time callers now have download privilege, so feel free to dial in and poke around. SYS\$OUTPUT (FidoNet 1:129/38) is up 24 hours a day at (412) 854-0511. Look for the online listing of DEC-related FidoNet BBSS or send a self-addressed, stamped envelope to: BBS List, Kevin G. Barkes Consulting Services, 4107 Overlook Street, Library, PA 15129. —Kevin G. Barkes is a specialist in VAX systems software, management, tuning and training.

**WE
SPEAK
YOUR
LANGUAGE.**

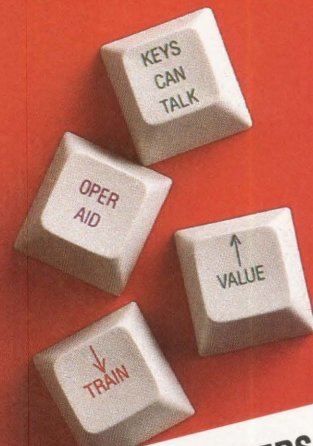

**DEC TECHNICAL CHARACTERS
and
WORD PERFECT
Keysets Now Available!**

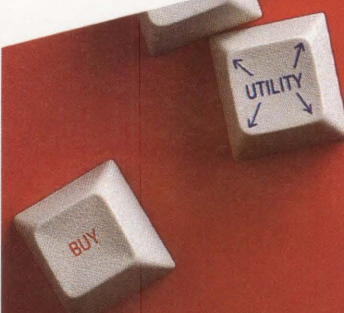

- Increase value of system
- Decrease training time
- Decrease error rates
- Increase productivity
- Fully utilize your system

Give your keyboard the legends, characters, languages, & symbols you want.

DEC, IBM, WYSE, & others. We stock EDT & Word Processing also. Call Lee or Daryl today for details. (619) 581-6303

Syntronics

4901 Morena Boulevard, Suite 302
San Diego, CA 92117

Most purchasing software systems promise great performance.



As long as they call the tune.

Adapting software to your unique purchasing requirements can cost a fortune. Unless you buy Cardinal.

With Cardinal, you get the fit and functionality of custom software at a fraction of the cost. This means you can specify as many unique order types as you need. You can specify how each will be processed. And you can do all of this quickly and easily — without programming.

No other approach to purchase order management gives you anywhere near this much flexibility. Cardinal's

unique architecture lets you define and process requisitions, blanket contracts, standing orders, import orders — any kind of order — any way you like. And as your order processing requirements change, your systems can change with them — without reprogramming.

So why settle for an inflexible order management system? Or spend a fortune on custom software development? Call Cardinal. And get to call your own tune.

 cardinal data corp

75 Second Avenue, Needham, MA 02194 • (617) 449-0066
Distributors: Los Angeles (714-554-1551) • Sydney (2-436-4022)

**INTEGRATED SOFTWARE FOR: ORDER MANAGEMENT • PURCHASING • INVENTORY
• RECEIVABLES • PAYABLES • GENERAL LEDGER**

CIRCLE 195 ON READER CARD

Introducing Reflection 4. VT241 emulation to satisfy your ReGIS appetite.

Appetizers

VT240/241 emulation
VT220 emulation
Tektronix 4010/4014 emulation

Entrées

VT340 ReGIS graphics
Addresses LIM expanded memory
Keyboard remapping
Fast, accurate file transfer
Downloadable character sets
LAT protocol support
Automatic ALL-IN-1 and
VAX Mail pickup

Desserts

Backup to VMS or UNIX
LAN support
Microcom Networking Protocol*

*MNP support \$50.00 when in season.

WFO Specialties

Features which place Reflection a cut above.

Command Language

Robust script language ideal for automating frequently used routines.

Multitasking

Hot-key between your favorite PC program and leave your VAX session running.

Conserve RAM

You can configure Reflection to load only the features you use.

ReGIS Graphics

16 colors, all ReGIS commands, including: polygon fill, 4 cursor styles, mouse support.

Combinations

Served with complementary technical support and complete documentation.

Reflection 4 Plus

All menu items with dessert of Backup and LAN.
\$349

Reflection 4

All menu items except dessert.
\$299

Lighter Fare

Reflection 2 Plus

VT220, Tektronix 4010/4014, with dessert of Backup and LAN.
\$249

Reflection 2

VT220 served without dessert.
\$199

A well-balanced communications diet requires more than functional emulation and error-free file transfer. High-performance VT241 emulation and ReGIS graphics are just a beginning with Reflection 4.

Reflection uses less RAM than the competition. So there's more room for your other PC programs when Reflection is in the background.

We think you'll find our hearty command language ideal for writing cus-

tom user interfaces, or for automating complex or frequently used routines.

With the PLUS option, you'll never fear a changing communications environment. PLUS supports popular LANs and LAT protocol under DECnet DOS. You can even back up PC files onto any VAX, UNIX or ULTRIX system.

Trade up to Reflection 4 PLUS, the full-course ReGIS emulation software. Send us the original diskette to

any VT240/241 emulator and \$100, and we'll send you Reflection 4 PLUS. You can trade up to Reflection 4 PLUS for \$200 with any other VT emulator.

REFLECTION™
SERIES
SOFTWARE

from Walker Richer & Quinn, Inc. ☞

1-800-8PC-2VAX

2825 Eastlake Ave. E. Seattle, WA 98102
U.S.A. (206) 324-0350 Telex 311743 WRQUR
Offer good through June 30th, 1988

CIRCLE 167 ON READER CARD

Identifiers In Function Prototypes

Editor's note: In April, our C language editor and representative on

the ANSI C Standards Committee, Rex Jaeschke, submitted the following paper, edited for publication, to the ANSI C Standards Committee, in Nashua, New Hampshire.

I've been using a number of compilers, including VAX C, that support function prototypes, and I've come across a potential problem regarding the naming of the optional identifiers in the prototype argument list.

These identifiers have their own namespace; they're known from the point of their declaration through the end of their parent prototype. Therefore, they can't conflict with other namespaces. However, the preprocessor doesn't know about C's identifier namespaces, and it looks for tokens that match its macro names, replacing them without regard for where they are in a C program, prototypes included. For example:

```
#define status 23

#include <stdlib.h>
/* which contains the prototype:

void exit(int status);

*/
```

generates a syntax error, because the prototype becomes:

```
void exit(int 23);
```

Another problem occurs when **status** is defined as follows:

```
#define status []

void exit(int status);

main()
{
    int i[5];
```

```
    exit(i);
}
```

Now the prototype is changed, so the call to **exit** is deemed to be correct, when it's really an error.

A programmer shouldn't be able to inadvertently or intentionally circumvent a standard header prototype. Prototypes in users' own headers or those

ANSI C Standard Meeting Report

At the December 1987 meeting in Austin, Texas, there was a last minute push to incorporate some kind of syntax within a prototype to indicate to a compiler that the incoming arguments didn't overlap. This was of particular interest to those members implementing on systems with vector processing hardware. Optimizers also were interested.

As a result, a palatable idea was proposed and many senior committee members worked into the wee hours over several days, drafting exact words. The proposal was to add a new keyword, **noalias**, that would be a type specifier like **const** and **volatile**. On the last day of the meeting, the **noalias** proposal was adopted, and we voted out the standard for its second public review for a two-month period.

Word of the new keyword spread throughout the C community, and loud objections began filtering back. The most noticeable objection came from Dennis Ritchie, the principal designer of the C language. He submitted a public comment saying that he didn't like our solution and also attended the Nashua meeting, his first.

He objected to the haste with which the keyword was added and didn't think it solved the problem. He also thought it incorrect to use a type specifier as the solution. His final statement was, "It must not survive."

Several others who had voted for it in December, spoke out against it in April, and, buoyed by Ritchie's persuasion, we voted **noalias** and its associated baggage out of the Standard.

This occurred on the first day of the meeting. The rest of the week was dedicated to sifting through several hundred pages of public comments. To expedite things, we broke into three- to four-person subgroups. Each group had to screen its set of issues, identifying those needing full committee attention. Although there were a few substantive changes to the draft, the largest number were editorial changes to both the draft and Rationale Documents.

At the end of the meeting, we voted out the draft for another two-month public review period. At the August meeting, we'll repeat the same process and the final Standard could be voted out at that meeting. Of course, we always could choose to make one or more substantive changes; in which case, the process begins again.

—Rex Jaeschke

For a copy of the latest ANSI draft and rationale documents, contact Global Engineering Documents Inc.; (800) 854-7179. Price: \$65.

CIRCLE 501 ON READER CARD

of third-party layered products are another matter.

Perhaps this is a quality-of-implementation issue, but the implementations I've been using are represented on X3J11, so I feel compelled to raise the issue. As I see it, the solution is to place two underscores (or one underscore followed by a capital letter) in front of all argument identifiers in the library prototypes throughout the draft Standard.

This should solve the problem, because implementers seem to be writing their prototypes using the same names as the draft (or at least they're using these as examples). Of course, they could choose to leave out the names altogether. Perhaps some words are appropriate for the Rationale Document as well.

Because we've explicitly reserved the namespace of identifiers beginning with underscores, we should follow our own advice. User and third-party product header writers can omit the names (preferable) or reserve the names they use. However, I expect the latter to be less than palatable by users porting code.

By the way, I believe the issue of style (i.e., making macro names all uppercase) is irrelevant, because we explicitly give the space of upper- and lowercase names without leading underscores (with noted exceptions) to the user.

Author's Note: The committee agreed that it need not change the standard but should explain this possibility in the Rationale Document that accompanies the draft. The net result is that implementers shouldn't use identifier names that belong in the programmer's namespace. ■

NOW AVAILABLE! BACK ISSUES OF VAX PROFESSIONAL The Software Journal for VMS

Issues dating back to December 1983, are now available at only \$4 an issue. That's \$88 for a 22 issue set. This is your chance to replace your worn-out copies and missing issues.

Over the years, VAX PROFESSIONAL has covered the important topics on VAX/VMS systems. Six issues a year, filled with articles by hands-on experts like Bill Hancock, Al Cini, Dave Mallery, Carl Marbach, Rex Jaeschke, Kevin Barkes and many more.

Complete your computer library, order a set of 22 available back issues. Then, when you need technical software information, you'll reach no farther than your book shelf.

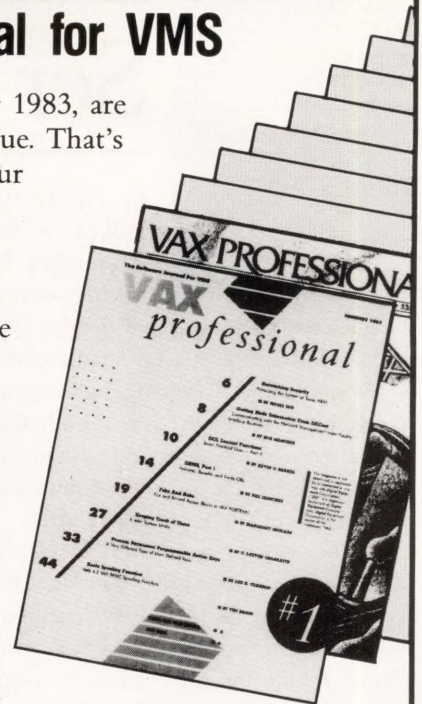

ORDER YOUR SET OF AVAILABLE BACK ISSUES NOW!

FOR FAST SERVICE CALL (215) 542-7008
with credit card information or complete and
mail the form below.

▼ Clip and Send ▼

VAX PROFESSIONAL BACK ISSUE ORDER FORM

YES, I want _____ back issue set(s) at \$88 per 22 issue set.

Payment enclosed for \$ _____

Charge to VISA MasterCard

(Canadian orders add \$10 shipping for each set.)

Account # _____ Expires _____

Signature _____ Date _____

Name (Please print) _____

Company _____

Address _____

City _____ State _____ Zip _____

Telephone (_____) _____

ALL ORDERS MUST BE PREPAID

Make checks payable and send to:

VAX PROFESSIONAL, P.O. Box 504, Spring House, PA 19477

DP788

Ron Levine

DEC's After Your Service \$\$\$ Too

In April, we looked at the advantages of having maintenance services for mixed-vendor systems from third-party maintenance (TPM) companies. TPMs are capturing an increasing percentage of the multibillion dollar service revenues and provide an alternative to the original equipment manufacturer's (OEM) service arm.

The OEM, specifically DEC, is aware of the inroads made by the TPM companies on its previously exclusive system service turf. And, DEC isn't about to sit by idly, while a major revenue source is under attack.

In fairness, *DEC PROFESSIONAL* asked DEC if it would like to respond to the TPM article, and respond it did. DEC U.S. Field Service Management offered its side of the OEM versus TPM controversy.

Although DEC, like other OEMs, at first either refused to maintain non-logo products or serviced them at customer insistence, its attitude has changed. Now, DEC wants your service business, even if you have non-DEC equipment in your site environment, and it has taken steps to obtain it.

Doing Something Right

DEC bashing seems to be in style these days, according to one of my sources. Probably it's the mark of success. IBM has been a target of criticism for everything from product technology to software introductions, from pricing to policy. The industry analysts, consultants and trade publications like to fault anything and everything that comes from Big Blue. The fact that DEC is a

In April, we looked at the advantages of having main-

tenance services for mixed-vendor systems from third-party maintenance (TPM) companies. TPMs are capturing an increasing percentage of the multibillion dollar service revenues and provide an alternative to the original equipment manufacturer's (OEM) service arm.

The OEM, specifically DEC, is aware of the inroads made by the TPM companies on its previously exclusive system service turf. And, DEC isn't about to sit by idly, while a major revenue source is under attack.

In fairness, *DEC PROFESSIONAL* asked DEC if it would like to respond to the TPM article, and respond it did. DEC U.S. Field Service Management offered its side of the OEM versus TPM controversy.

Although DEC, like other OEMs, at first either refused to maintain non-logo products or serviced them at customer insistence, its attitude has changed. Now, DEC wants your service business, even if you have non-DEC equipment in your site environment, and it has taken steps to obtain it.

Doing Something Right

DEC bashing seems to be in style these days, according to one of my sources. Probably it's the mark of success. IBM has been a target of criticism for everything from product technology to software introductions, from pricing to policy. The industry analysts, consultants and trade publications like to fault anything and everything that comes from Big Blue. The fact that DEC is a

“
... DEC isn't about to sit by idly,
while a major revenue source is under attack.
”

target of many of these same reviewers is a mark of success; DEC is now in the same league as IBM.

Such scrutiny comes from market acceptance. Corporations don't purchase additional products from a vendor if past experiences have been negative. Obviously, IBM and DEC have a lot of satisfied customers.

Turning to field service, DEC's growth has been tremendous. Revenues increased 26 percent in fiscal 1987 over 1986. Customers served exceed 50,000. This kind of growth doesn't occur without customer satisfaction in both the product and service. DEC must be doing something right.

DEC Service Offerings

DEC has divided its field support services into a number of categories. Each of these services is available independently or as part of a total customer support package. In general, they are:

1. Network Design Consulting — This includes the planning, design and implementation phases of networking.
2. Site Design Services — This helps to determine proper power levels and distribution, air conditioning and other environmental requirements, site construction, size, clearances and other physical attributes. An AI-based software package is used as a support tool.
3. Installation Services — This places systems or equipment on site, provides

startup and trains operators.

4. Operational Support — This is DEC's major field service program. It can include network management, system series, system management, standard remedial services, disaster recovery and environmental services, including site audits.

System services can include customer use of an expert system (Digital Software Information Network [DSIN]); on-site repairs for critical applications (both hardware and software); an on-site account representative from field service; and telephone support (24 hours, seven days per week).

System management includes all system service, plus performance analysis and monitoring, proactive preventive maintenance and a designated account manager at the Customer Service Center.

Standard remedial services are hardware troubleshooting and repair, and hardware parts replacement.

5. Training — This provides complete end user courses for both hardware and software products.

6. Warranty — DEC warrants its entire product line for one year; this includes hardware and software, parts and labor.

DEC includes a defined escalation clause in all its service contracts, specifying actions that will be taken if a problem exceeds local level resolution.

Our heritage is your best assurance of superior nationwide service and maintenance of multi-vendor computer peripherals.

When you need reliable service and maintenance support, put yourself in the hands of experienced professionals. Dow Jones & Company, Inc.

With factory-trained technicians in 76 centers throughout the U.S. and Canada, we can provide flexible service/maintenance packages to meet all your current and future needs. These include: On-site Maintenance, Express Depot

Service, Extended Factory Warranty Service, Emergency Repairs/Time and Materials, Replacement Parts Inventory and Systems Configuration Capabilities.

We specialize in P.C. installations of 25 units or more. We also offer substantial VAR and OEM discounts and an especially lucrative dealer rental program. For more information, call the toll-free number below from 8 a.m. to 5 p.m. PST. Let us give you a hand.

DOW JONES SERVICE

1-800-532-7373

CIRCLE 272 ON READER CARD

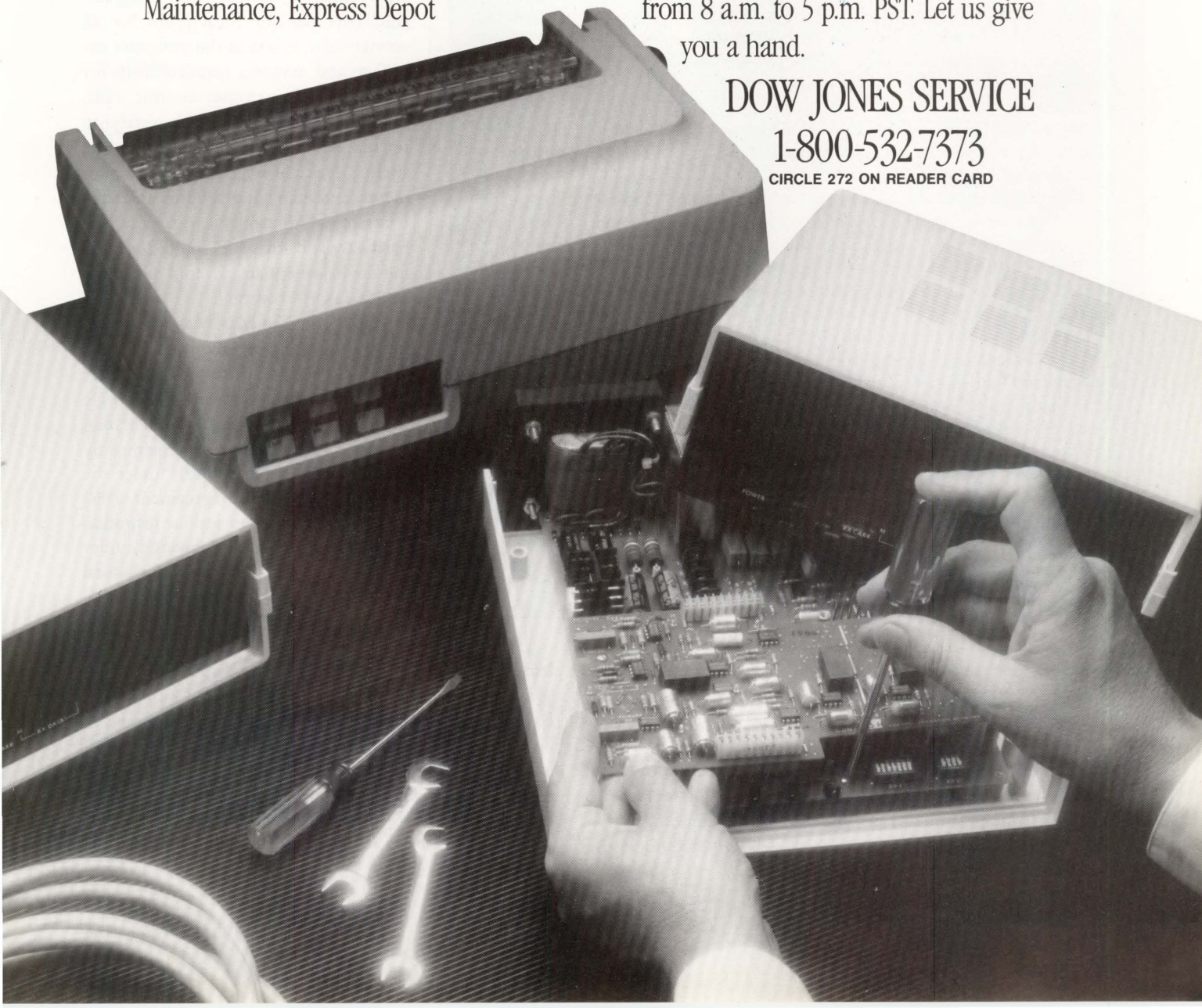

The Parsing Group

In May, some of the biggest and best-known independent maintenance providers to the DEC user base met in San Luis Obispo, California, to map the future of the service industry. Companies represented included Control Data Corporation, General Electric, Grumman Data Systems, Maintech, Unisys, ESS, Douglas Computer International and British Columbia Telephone Company. The conference was created and chaired by Parse Inc. of Hudson, Massachusetts, an independent supplier of DEC-compatible diagnostics to the third-party maintenance (TPM) industry. It was convened to explore the possibility of forming a users group to cooperate in areas of mutual interest in the DEC services market.

Billed as the industry's first diagnostics standards meeting, this influential group expanded the agenda to include precedent-setting discussions on other subjects of importance to the independent service industry and its customers. Topics tackled ranged from parts availability to the impact of new technology, ethical standards in dealing with customers to the increasing difficulty in dealing with DEC. Lessening the independents' and users' reliance on DEC for technical drawings, manuals, parts and diagnostics was a major theme of the conference.

The keynote address, given by *DEC PROFESSIONAL*'s editorial director, Dave Mallery, set the tone of the conference by describing the changing role of support required to service customers today versus the traditional service call of 1980. Mallery also touched on new problems for the TPM providers as standalone DEC systems give way to networks and clusters encompassing hardware and software from multiple vendors, resulting in interconnectivity problems.

He assessed the increasingly rapid obsolescence of installed equipment, the proliferation of new machines and technologies, and the push toward interoperability and what this means to TPMs.

Other topics included legal issues and what to do as DEC moves to protect its territory. With annual service revenues for DEC-based systems projected at topping \$6 billion within five years, DEC will pull out all the stops to protect its business.

Paul Files, Parse's vice president of marketing, stressed that the purpose of the Parsing Group isn't to displace other established industry groups but to provide a forum where Parse's customers can talk to each other about marketing issues, technology, documentation, training, spares and other subjects of importance to the TPM industry. The group will serve as a mechanism for making its needs known to vendors who supply hardware, software and services to the independent maintenance industry. "The Parsing Group will discuss the issues we all need to understand if we are going to be successful in the marketplace," says Files.

Parse doesn't view its plunge into the DEC world as competing with DEC. Files stated, "We produce VAX software to sell into the TPM market. We are not competing against DEC, as it doesn't sell the independent vendors its established software packages. We are attempting to fill that void."

In closing, the conference attendees set the agenda for the next meeting, also to be held in San Luis Obispo, in October. All participants are preparing specific topics to be discussed at that time along with formal association creation plans.

Additional DEC resources are available at specific time intervals to back up the field personnel.

Mixed-Vendor System Servicing

An argument for using a third-party maintenance organization is its will-

ingness to service the complete computing environment. TPMs have no stake in any specific equipment brand, and, therefore, have no self-serving interests. They want your service business only and aren't interested in future sales of logo products.

DEC counters that it's also in the

service business. Approximately one-third of DEC's revenues and a larger percentage of profits last year came from the service sector. DEC doesn't want to lose this business to TPMs, and so it has implemented its own versions of third-party maintenance programs.

DECOMPATIBLE Service provides coverage of DEC and a large assortment of non-DEC equipment, residing on or networked to DEC systems. More than 200 non-DEC products from more than 50 vendors are supported corporate-wide. More than 1,000 non-DEC products are supported at local levels.

Another DEC program, NETSUPPORT Service, provides ongoing maintenance management to customers with multivendor computer network environments. Under this program, DEC becomes the focal point for all service calls; it acts as the customer interface and assumes responsibility for managing all customer trouble calls, tracking repair activities, verifying repairs, handling administrative issues, such as contract negotiations and payments, and managing vendors and subcontractors. All products (e.g., network, hardware and software) in the computing environment are covered under the NETSUPPORT contract.

According to Max Mayer, marketing and sales support manager for DEC U.S. Field Service, these programs offer the customer a cost-effective single source of service. With DECOMPATIBLE Service, all maintenance is performed by DEC's field engineers (FEs); under the NETSUPPORT service agreement, DEC manages vendor field service response. All parts and labor are covered under both types of contracts, providing a total system service approach without any unbudgeted surprises.

Tools For Field Support

DEC is proud of its development and use of state-of-the-art technology in customer support endeavors. As proof of its commitment to customer satisfaction, DEC points to heavy investments

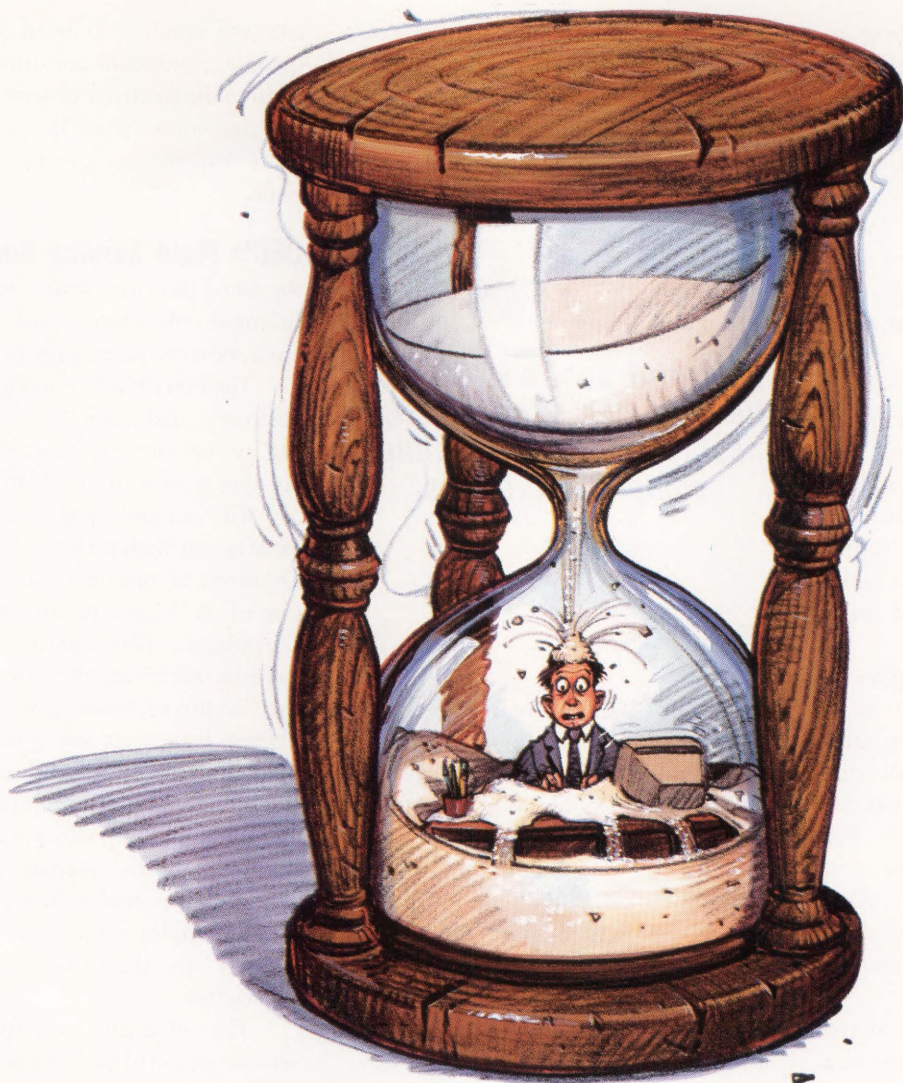

The longer you wait, the deeper it gets.

When your computer's down, every minute counts. And costs.

That's why Sorbus,SM the world's leading independent computer service company, *guarantees* four-hour response time on DEC equipment. (We're shooting for two hours, our average on all equipment.)

And our average repair time is only *one and one-half hours*.

In other words, we average about three and one-half hours from crashed to crunching.

We cover more than 3,000 different hardware products—mainframes, minis, micros, peripherals. Including DECTM PDP-11XX, MicroVAX I and II, and VAX 11/7XX. And more IBM[®] equipment than anyone but IBM.

Altogether, we maintain more than 400,000 pieces of computer hardware at 60,000 sites nationwide. Chances are, we should be maintaining yours, too.

So call Sorbus today. While there's still time.

1-800-FOR-INFO.

SorbusSM
A Bell AtlanticTM Company

50 E. Swedesford Road
Frazer, PA 19355

Sorbus is a service mark of Sorbus Inc.

IBM is a registered trademark of International Business Machines Corporation.

DEC is a trademark of Digital Equipment Corporation.

CIRCLE 158 ON READER CARD

in its field support services. These include a \$50 million Customer Support Center (CSC), more than \$100 million spent developing diagnostics tools and a \$.5 billion spares inventory in the U.S. Each FE answering a Model 8000 product call carries an average of \$56,000 worth of spares. DEC has poured more than \$1 billion into its field operations.

Some of this new field technology includes the use of AI and expert system-based tools to replace remedial service with predictive maintenance. Using these diagnostic packages, DEC FEs can remove and replace modules and other system parts before they fail, thus providing service without waiting for customer downtime to occur (commonly known as uninterrupted maintenance).

The remote troubleshooting and AI combination ensures that when an FE arrives at a site for remedial maintenance, he knows which modules or components are probably the culprits and has the replacements with him. This becomes a quick-fix situation with minimum system downtime. Most hardware problems are resolved within two hours (on 8000 series systems, this is guaranteed).

Remote troubleshooting techniques also are effective in the software area. Approximately 90 percent of all software problems are resolved over the telephone via downloading of updates or patches.

DEC's Customer Service Centers (CSCs) provide centralized dispatch and support for users of DEC's services. For 24 hours a day, seven days a week, customers can call the CSC, talk to an expert and receive help diagnosing any system or network problem; e.g., compatibility, communications, hardware or

software. FEs at customer sites also call in when support is required.

The CSC also provides access to the DSIN. This is a series of online databases that the customer accesses for informa-

“

The third goal was to have field service support DEC's corporate goal of selling complete solutions.

”

tion. It's an expert system that employs an easy-access English inquiry methodology to acquire data on problems that have been resolved by others, or to use to look up subjects of interest.

Trends In Service

Trends in field service show that customers expect more total systems solution support from their field service vendors, according to Nicholas Houppis, DEC's PR manager for U.S. Field Service. "Remedial service is only one piece of customer support. There's a lot more to service than fixing a machine when it's broken," he observes. Complete hardware, software, network and operational support, along with system management consulting and training, are demanded by customers. Because of the importance of the network in corporate well-being, downtime can't and won't be tolerated; many customers already expect uninterrupted service, and it will become the norm in the near future.

Another trend is customer preference for contracting with a single-source service vendor. The customers prefer this, and vendors who aren't listening will lose marketshare.

Today, DEC is determined to be the quality provider of that single-source service at DEC-based sites; to that end,

DEC will continue to invest its resources (people, equipment and money) to remain in the forefront of service technology and innovation. To DEC, it's still, more than ever, a customer satisfaction issue.

DEC's Field Service Goals

We asked DEC to describe its customer-oriented objectives and goals. Its answers were direct and to the point.

The first objective was gaining total customer satisfaction, "... a good feeling by the customer toward DEC," according to one of DEC's managers.

The second goal was employee satisfaction within DEC's Field Service Division. According to Mayer, DEC has one of the lowest FE turnover rates in the industry. This enables the company to focus on serving the customer rather than on hiring, training and recruiting. "If you have a revolving door type of operation, the FE responding to a call is not as well prepared to quickly resolve a problem as an FE who's been involved with the specific customer or application over a period of time," he points out. So employee satisfaction is related directly to the goal of customer satisfaction.

The third goal was to have field service support DEC's corporate goal of selling complete solutions. This means field support instead of just field maintenance; providing the DEC service customer with all the tools needed for maximum efficiency. It includes predictive and preventive, as well as reactive and remedial maintenance; training for end user personnel; and assistance in planning, implementation, operation and support of the entire computing environment. DEC believes it does this better than any TPM company, and this approach to service and support sets it apart.

DEC also has set for itself a goal that concerns FE training. A program now under way will ensure that all FEs approach service from a system's view-

Digital Equipment Corp.
146 Main St.
Maynard, MA 01754
(617) 897-5111
CIRCLE 576 ON READER CARD

MORE THAN A DATABASE FOR THE DEPARTMENT COMPUTER

Over the noise of corporate issues, your department's computing needs are not always heard. In the stack of things to do, they often wait at the bottom of the pile.

RDM is the ONLY application developer designed specifically to get department software development done. More than just a database, **RDM** is a complete application development system AND full relational database — integrated into one flexible, table-driven tool.

RDM's table-driven technology is a generation beyond conventional database development. **RDM** supplies all the parameters that shape standard application components. You add your own custom-designed specifics. **RDM** eliminates the need to code and recode routine application features.

RDM is nonlanguage, fill-in-the-form application development. With no programming code to analyze, the learning curve is short and productivity increases. With or without software development specialists, you create the entire application: data input forms, summaries and reports, command menus, on-line help files and processes to validate and manipulate data. You'll implement even the most procedural tasks — without procedural language syntax.

After initial software development — your department's needs will evolve. **RDM** makes system modification and maintenance easy. You add new forms and reports — when you need to. You create new files or change data relationships — quickly. And without any change or rewrite, **RDM** applications will transfer and share data across 10 different operating systems. You save time and money with one software product for your VAX, PDP-11 and IBM-PC.

Since 1980, **RDM** has been the choice of more than 2500 departmental application developers. For quick application development and easy maintenance, for increased productivity and extended portability, for stand-alone, integrated, distributed or networked systems . . . there's no better software solution than **RDM**.

Find out how your applications can rise to the top of the stack. Call today.

800-362-6203

In Canada, call 800-255-6378



Interactive Technology, Inc.
460 Park Plaza West
10700 SW Beaverton-Hillsdale Highway
Beaverton, OR 97005
503-644-0111
TLX 703920

RDM®

CIRCLE 190 ON READER CARD

VAX and PDP-11 are trademarks of Digital Equipment Corporation. IBM-PC is a trademark of IBM. RDM is a trademark of Interactive Technology, Inc.

Introducing PVCS for VAX/VMS

The Leading Configuration Management System.

Unmatched Flexibility and Price/Performance

The POLYTRON Version Control System (PVCS) simplifies and automates Configuration Management so programmers and managers can effectively control the revisions and versions of source code. Compare PVCS to DEC's CMS and Softool's CCC and you will see why PVCS is the most widely used change control product.

Project Control

PVCS maintains a history of revisions to a source document and allows prior versions to be recreated very quickly at any time. The "source document" can be any file written in any language. This means program source code, object code, libraries and project documentation can each be stored and maintained in an individual PVCS "archive."

Unmatched Flexibility

- Storage & Retrieval of Multiple Revisions of Source Code
- Maintenance of a Complete History of Changes
- Control of Separate Lines of Development (Branching)
- Resolution of Access Conflicts
- Optional Merging of Simultaneous Changes
- Release and Configuration Control
- Project Activity Reports
- Management Reports
- Command or Menu Interface

Fast Retrieval of Revisions

PVCS uses "reverse delta storage" which saves disk space and speeds retrieval of versions of any file in the project database. A delta is the set of differences between any revision and the previous revision. PVCS can rapidly recreate complete versions of any file whether it is the most recent revision of a module or the original version of the entire project. Differences are automatically detected and stored.

A Practical Necessity for Workgroups

While important for single-programmer projects, PVCS is absolutely essential for multiple-programmer projects where files are simply too easy to change. Because any change to any file can have major ramifications, coordinating and keeping a record of changes is critical. Project leaders can determine, on a module-by-module basis, which programmers can access or modify source files, libraries, object code and other files. The levels of security can be tailored to meet the needs of nearly every project.

Adopt PVCS on Your Existing Projects

You can obtain the benefits for your current project without disrupting development, regardless of how long your project has been underway. You can build PVCS archives from revisions stored in your present files or simply adopt PVCS from the current date.

Personal PVCS (MS-DOS) — Offers most of the power of Corporate PVCS, but excludes features necessary for multiple-programmer projects. \$149

Corporate PVCS (MS-DOS) — For managing large, multiple-programmer projects. \$395

Network PVCS (MS-DOS) File locking and security levels can be tailored for each project. \$995 for a 5 station LAN

PVCS for VAX/VMS — Uses same archive format and interface as MS-DOS versions and manages large, multiple-programmer projects. MicroVAX \$4,950, VAX 7XX \$9,500, VAX 8xxx \$10,500+

TO ORDER:

1-800-547-4000

Dept. DEC

Oregon & Outside USA

Call (503) 645-1150

Send Checks, P.O.s to:
POLYTRON Corporation
1700 NW 167th Place
Beaverton, OR 97006



High Quality Software Since 1982

CIRCLE 240 ON READER CARD

point and from the user's application side. FEs assigned to sites on a regular basis will be taught a basic understanding of the user's application. This will decrease the time it takes to place a system back into full operational status, as

“

FEs assigned to sites on a regular basis will be taught a basic understanding of the user's application.

”

most problems today aren't isolated hardware or software failures but are caused by an integration of the two.

DEC Service

DEC is serious about its service business. Last year, service revenues made up approximately 33 percent of DEC's total income and more of its profits. Although getting into third-party maintenance probably was more of a defensive move than an assault on new territory, DEC is entrenched in mixed-vendor equipment servicing.

With corporate integration of systems taking place at a rapid pace, and the proliferation of multivendor networks throughout the business world, DEC must service non-logo products if it wants to hold onto its customer service base and extend its marketshare. But DEC isn't competing in the general TPM markets; it services mixed-vendor systems at DEC sites only, as part of its customer satisfaction policy.

DEC wants your service dollars. It's offering the type, quality and variety of field support services necessary to attract those dollars. As the OEM of the basic CPU and other system and network components, DEC service is a viable alternative to TPM vendors and another available option for the service purchaser. ■

The following are trademarks of Digital Equipment Corporation:

A-to-Z	DECnet	IAS	PDP	VAX
ALL-IN-1	DECsystem-10	IVIS	PDT	VAXBI
CDD	DECSYSTEM-20	LAN Bridge	PICOS	VAXcluster
DATATRIEVE	DECtest	LA50	Q-bus	VAX DIBOL
DDCMP	DECLUS	LA100	Rainbow	VAXELN
DEC	DELNI	LQP02	RALLY	VAXFMS
DECcalc	DIBOL	LSI-11	Rdb/VMS	VAXlab
DECconnect	DNA	MASSBUS	RSTS/E	VAXLISP
DECgraph	Eve	MicroPDP-11	RSX	VAX SCAN
DECmail	FMS	MicroPower/Pascal	RT-11	VAXstation
DECmate	GIGI	MicroVAX	TEAMDATA	VMS
			TOPS	VT
			ULTRIX	Work Processor
			UNIBUS	WPS

UNIX is a trademark of Bell Laboratories.
MS-DOS is a trademark of Microsoft.
CP/M is a trademark of Digital Research, Inc.
Macintosh is a trademark of Apple Computer, Inc.
X Window System is a trademark of MIT.

NEW!
from SIGMA

THE 3 R's. . . REMOVABLE, RUGGED, AND READY!

Sigma's new 5-1/4" removable drive enclosures will give you the versatility to access, transport and store data!

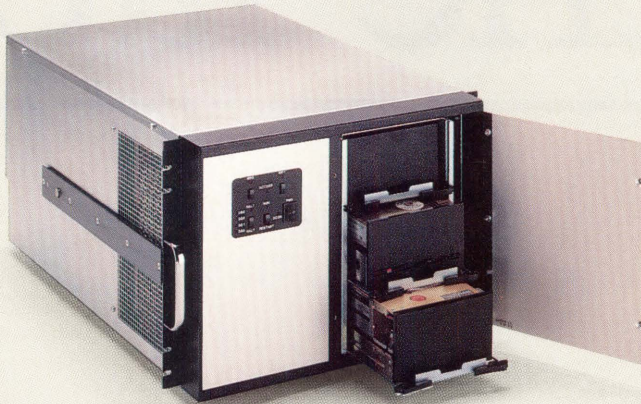

SA-H163

- RUGGEDIZED
- REMOVABLE
- RELIABLE

SIGMA's rugged enclosure with dual 5-1/4" removable Winchester disk drives in the SA-H163, offers a small chassis for installation in a standard 19" RETMA rack. The SA-H163 includes a 100 watt power supply, as well as a controller interface panel. The unit is equipped with write protect switches and LEDs for each drive.

SA-H168

- REMOVABLE
- RUGGEDIZED CONSTRUCTION
- HEAVY-DUTY POWER SUPPLY

SIGMA's ruggedized SA-H168 is a tough, self-contained chassis for industrial and military applications. Equipped with shock-mounted drive frames containing mounting slots for three full-height 5-1/4" Winchester and/or removable media drives. The SA-H168 includes a 14-slot quad-wide fully-terminated backplane with 0.6" spacing for improved air flow and easier cabling and board installation. This chassis contains a heavy-duty 480 watt power supply.

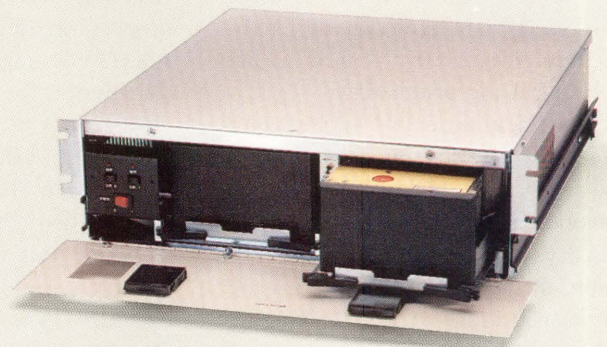

SA-H162

- BUSINESS APPLICATIONS
- REMOVABLE
- FREE-STANDING MODULAR DESIGN

SIGMA's ready for your business applications with the SA-H162 free-standing enclosure which provides mounting for a Micro-VAX II BA23* box plus additional space for four 5-1/4" ESDI or ST506 Winchester pluggable disk drives and an 8- or 12-slot expansion backplane. A modular pull-out drawer located at the rear of the chassis contains a 400 watt switching power supply assembly.

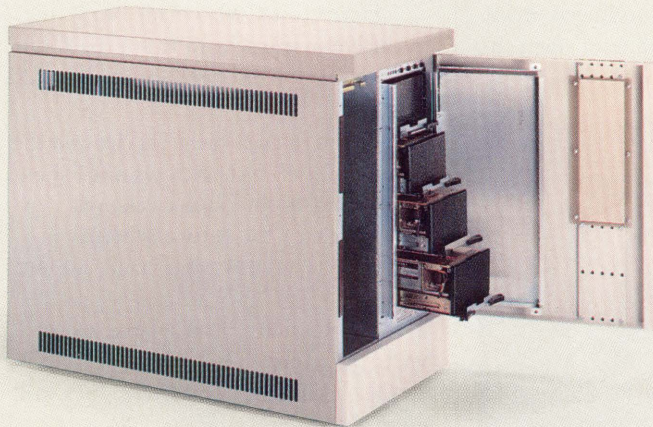

Remember to contact your nearest Sigma Representative for detailed information and prices on Sigma's DEC* compatible enclosure and Q-bus board products.

CA (714)633-0652	MA (617)938-6400	TX (713)690-8011
(714)771-7320	MD (301)921-8898	(214)790-2777
(408)241-3770	MN (612)435-6550	UT (800)521-3007
CO (719)528-8893	MT (800)521-3007	WA (408)241-3770
ID (800)521-3007	NM (800)521-3007	WY (800)521-3007

Belgium (02)7209038	Holland (01820)62911	Sweden (08)7680540
Denmark (06)848300	Italy (02)4459351	Switzerland (038)514353
Finland (00)52711	N.Zealand (09)590249	U.Kingdom (0372)378811
France (01)47862504	Norway (02)685230	W.Germany (02202)52042
Greece (01)9514944	International Sales Office: (022)711454	



**Sigma
Information
Systems**

3401 East La Palma Avenue, Anaheim, California 92806
(714) 630-6553 TLX 298607 SIGMA FAX (714) 630-5417

CIRCLE 263 ON READER CARD

from the lab



Requiem

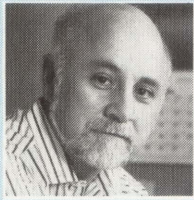

Dave Mallery

Our lives are measured in strange intervals. I'd like to share with you one that shaped my life and brought me to this day.

Historical note: PDP 11/70, s/n 5104 was installed by Dennis Faust of DEC Field Service and delivered to me on December 23, 1975. It ran 24 hours a day, seven days a week for 12 years and four months; that's 107,000 hours of non-stop service. Its original backplane, hanging on my wall, has a manufacture date of February 20, 1975.

Historical coincidence: I first met Carl Marbach when he came in from a snow storm a few days later to borrow a RSTS V5A distribution tape. Carl's distribution for his new 11/70 had the wrong boot block. Carl and I would like to thank DEC Field Service for the introduction. The rest is history.

The first "From the Lab" was written using this machine (see "Up the UNIBUS with Gun and Camera," *RSTS PROFESSIONAL*, Volume 2, Number 1). This seminal article convinced many people that it was possible to open the

cabinets without being struck by lightning.

Historical inevitability: OI' number 104 finally was replaced by an 8250 and decommissioned on April 22, 1988. The 8250 is already inadequate and being replaced by a larger VAX.

A Toast:

Here's to Ken Olsen, who had the guts and money to build this wonderful machine.

Here's to us, who made our livings in different ways from it and paid our bills to DEC while DEC built the VAX and VMS.

Here's to DEC Field Service and the dozens of its finest with whom I spent many long nights and weekends.

Here's to the future when:

1. System MTBFs approach 100,000 hours.
2. The Russians won't have to steal VAXs, just buy them.
3. Our childrens' childrens' toys still carry faint echoes of the DEC style of computing.

Twelve years later: Dave Mallery (left), Dennis Faust (center) of DEC Field Service and Harris Edelman, Dave's partner back then, pose with OI' number 104 for the last time.

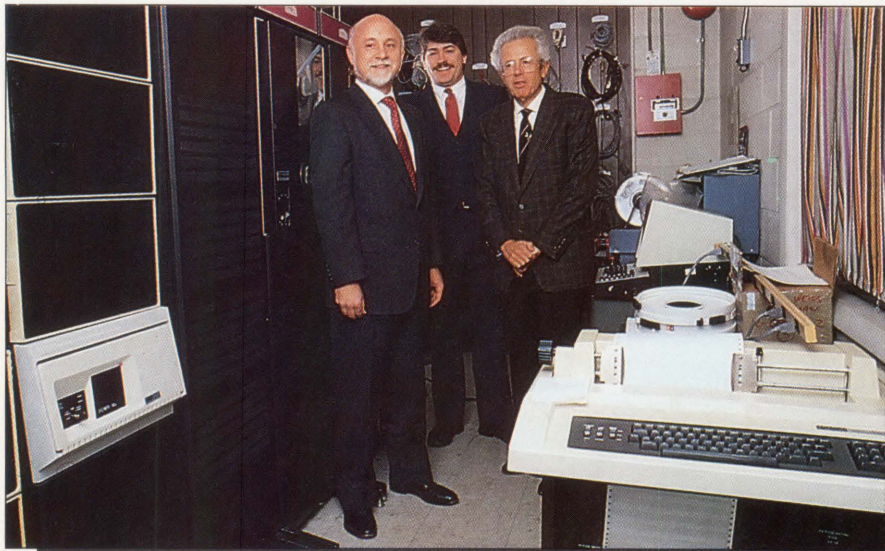

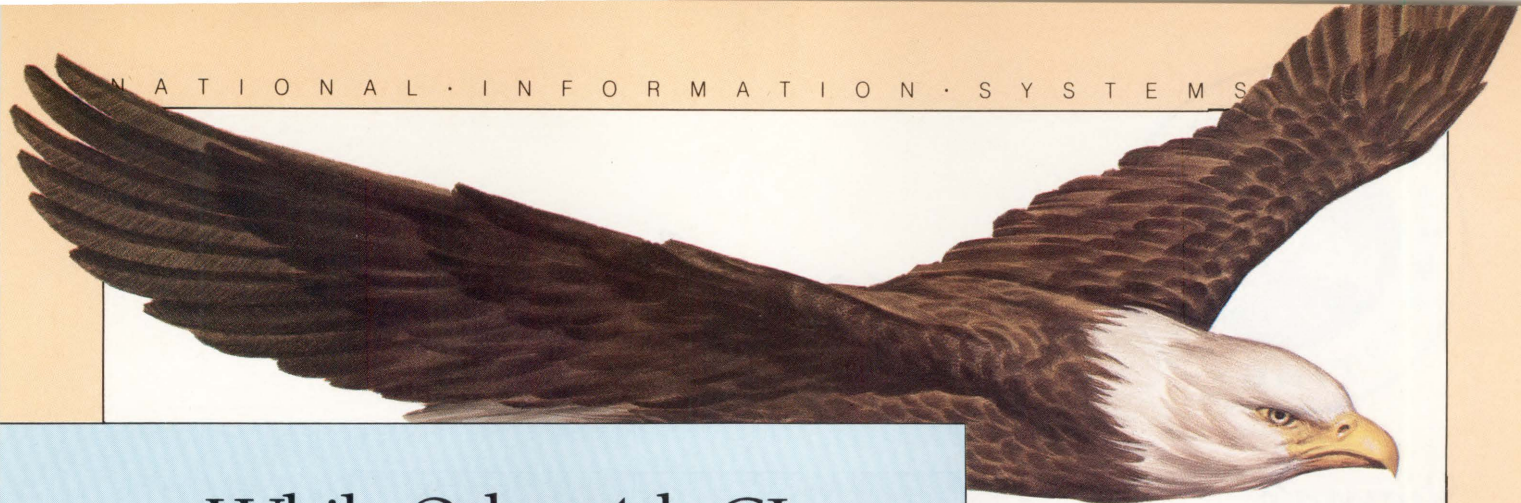

While Other 4th GLs Make You Crawl Through Programming, ACCENT R® Lets You Fly.

ACCENT R gets your VAX/VMS multi-user production applications off the ground fast.

The reason: Speed.

ACCENT R is actually much more than a 4th GL and RDBMS. It's a Total Applications Development Environment providing complete control.

For you, this means a product that finally breaks the language barrier. Simply, you'll never revert to Cobol, Fortran, or C again.

You take advantage of ACCENT R's powerful and efficient programming language. One that features "Application Models"—a unique framework for

dramatically reducing programming time; a full complement of debugging tools; error and syntax checking; and intuitive commands for prototyping and developing sophisticated applications.

ACCENT R even delivers custom reports, data entry and display forms, and menus; all without coding.

Still, that's not the only reason why applications developed in ACCENT R take wing. ACCENT R generates compiled code and is optimized for VAX/VMS environments. So your resulting multi-user applications can run as much as forty times faster than interpretive systems.

Better yet, ACCENT R even provides upward mobility for existing applications. That's because ACCENT R can use VAX RMS files.

Which means you can easily expand without redesigning your application or re-loading your data.



Fact is, ACCENT R will keep your applications flying for years. It's no surprise that FORTUNE 1000 companies, government agencies, and universities have chosen ACCENT R for developing their full-blown applications.

That's why you should call National Information Systems at (408) 985-7100 for more information. After all, why crawl through programming when you can now fly?

ACCENT R®
408-985-7100

National Information Systems, Inc.
1190 Saratoga Avenue
San Jose, CA 95129

CIRCLE 303 ON READER CARD

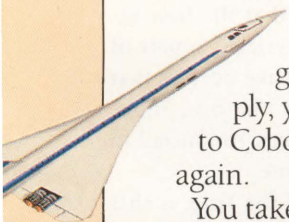



from the lab

Sigma's MICROVAX Expansion Box

Philip A. Naecker After you've owned a Digital MICROVAX in a BA23 cabinet with either the RD53 or RD54 disk, there are two things you might want: more expansion room and faster disks. With the vast array of Q-bus peripherals available at reasonable prices, you probably want to add more devices than your BA23 can handle. You might run out of a number of resources, such as backplane slots, bus loads, power, panel spaces or peripheral cavities. If you've been reading "From The Lab," you know that your MICROVAX will run faster and support a heavier load if you install any of the fast disks currently available.

The folks at Sigma Information Systems of Anaheim, California, pro-

SA-H162

Sigma Information Systems
3401 E. La Palma Ave.
Anaheim, CA 92806
(714) 630-6553
Price: \$3,188.

CIRCLE 512 ON READER CARD

Control Data Corp.
8100 34 Ave., S
Minneapolis, MN 55440
(612) 851-4131

CIRCLE 560 ON READER CARD

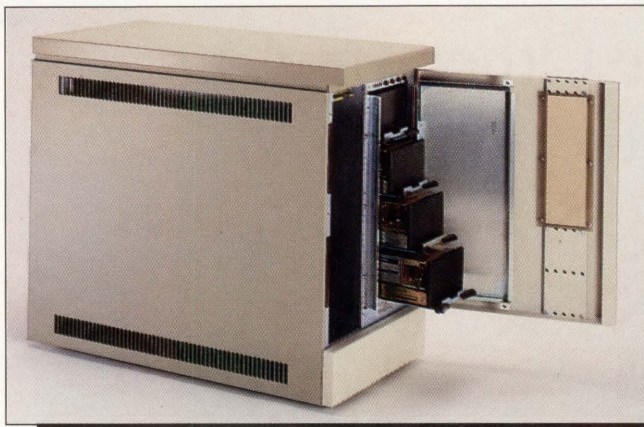

The SA-H162 comes with four B-size panel openings, a single A-size opening and a couple of extra openings.

vide a needed expansion path for your BA23 MICROVAX: an expansion cabinet especially designed to work with high-performance 5¼-inch ESDI disk drives. The SA-H162 provides eight additional Q-bus quad slots (16 dual slots) and mounting for four 5¼-inch ESDI plug-in drives. The H162 is configurable with a number of options, including cabling for the drives, an extra fan for each drive and a front panel for write protect. The cabinet tested in the Lab was fully loaded.

Your BA23-based MICROVAX probably is installed inside a plastic casing that acts as a floor stand or dust cover for a table-mounted machine. To use the SA-H162, slide your BA23 out of the case and into a slot on the left side of the H162. The BA23 is too heavy for this to be an easy procedure, but it's not complicated. Because the BA23 is unmodified by this procedure, it's still completely serviceable by your current field service organization.

Connect the new Q-bus expansion to your BA23 using a standard Q-bus extension cable that comes with the H162. This is a simple procedure that is well documented in the H162 manual.

The extension cable is passed through one of the A panel openings on your BA23 back cover. The back cover of the H162 includes a boot that fits over the BA23 panel slot, so the cable is protected as it leaves the BA23.

The H162 comes with four B-size panel openings, a single A-size opening and a couple of extra openings. You can use these panel openings with any device you install in the expansion backplane. In the Lab, we needed one of the openings to install the distribution panel for an RRD50 drive; we ran out of panel openings. Note that the new Q-bus is logically and physically a part of the old bus, so if you have devices that must be at the end of the bus, move them beyond any devices you install in the expansion backplane.

One advantage of the H162 is that you can order it prewired for four ESDI disks. In the Lab, we installed a CDC WREN-III ESDI disk drive (150 MB, less than \$10 per MB, and a 16 ms access time) and Sigma's ESDI controller, the SDC-RQD11-EC. Its controller works with the H162's front panel switches for

DEMAND MORE



...FROM YOUR VAX.

When VAX users demand the latest, most productive data analysis tools, they get them with SPSS software. SPSS offers the only family of analytical software that's created specifically for the VAX/VMS environment. Enabling everyone to get more work done while conserving system resources.

SPSS products let you do it all, from data management and statistics to producing professional reports, charts and maps. Ready to run on everything from VAXclusters™ to VAXmates™, they streamline every task.

Our SPSS-X™ mainframe system gives users the power to reduce mountains of data into meaningful information.

What's more, it comes with very special VAX options. Like SPSS-X Track™, a versatile system management tool that lets you perform complete performance monitoring, capacity planning and chargeback reporting. And SPSS-X Capture™, the data base interface that combines the data management capabilities of Datatrieve™ with the power of SPSS-X.

At SPSS, we've been producing software for the DEC community for over fifteen years! Now contact our Marketing Department to see what our products can do for you.

CALL 1/312/329-3304

SPSS inc.

SPSS Inc. • 444 North Michigan Avenue, Suite 3000 • Chicago, Illinois 60611

In Europe: SPSS Europe B.V. • P.O. Box 115 • 4200 AC Gorinchem, The Netherlands • Telephone: +31183036711 • TWX: 21019

VAX, VMS, VAXcluster, VAXmate and Datatrieve are trademarks of Digital Equipment Corporation. SPSS-X, SPSS-X Capture and SPSS-X Track are trademarks of SPSS Inc. for its proprietary computer software.

© 1987, SPSS Inc.

CIRCLE 159 ON READER CARD

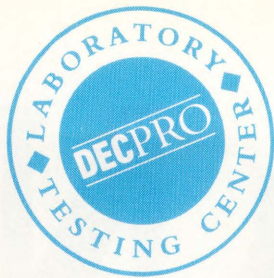

drive write-protect, and if you slip it into a slot in the expansion backplane, the cables from the drives connect easily. The SDC-RQD11 has 1 MB of cache and on-board formatting, test and verify logic.

The firmware is an easy-to-use menu, and we had no problem formatting our CDC drive as a DU-style MSCP device (it actually looks like an RA81 to the VAX). You also can use the firmware to create multiple logical drives on one physical drive or create shadow sets to protect against disk crashes.

To install a drive, remove one of the pluggable mounting brackets from the cabinet and screw your drive to the bracket. Set the address on your drive to seven, and remove the terminating resistor from the drive. Use the cables that come with the H162 to connect from the mounting bracket to the drive, and slide the bracket and drive in place. The pluggable connector on the bracket is Zero Insertion Force and rated for tens of thousands of connects/disconnects, so you easily can dismount your drive at anytime.

The drive gets its address from the slot you insert it in, so don't worry about conflicting drive addresses. Using a command procedure, you can teach VMS to use the volume name on the drive as the identification, so you could swap drives and reboot without even telling the VAX where the volume is located.

The H162 also makes it easier to work on your MICROVAX. The sides are removed easily (any 1/4-inch hex nut is for user access) and provide access to the drives and power supply inside the BA23. A door on the front of the H162 provides access to the BA23's power switch and the removable media. Another door inside the first provides access to the pluggable disk drives. The whole cabinet rolls on casters that keep the box low to the ground and stable,

but let you move it easily for working behind it.

There are more fans in an H162 than you had in your BA23, because there's an extra 400-watt power supply, which is a nice addition to your existing 240-watt supply in the BA23. By plugging in the disk bracket with a working drive, the fan for that drive cavity is powered up automatically, which is a feature that avoids running all the fans if you don't need them. The power supply sits in a special drawer at the bottom of the box, where the weight is distributed and the supply doesn't take up any footprint. The H162 power supply senses current in the BA23 and automatically switches itself on and off accordingly.

There are a few things that I thought could be improved in the H162. The position of the boot that covers the Q-bus extension cable conflicts with the standard location of the Ethernet port on a BA23. If it were moved to the lower panel slot, you wouldn't have to relocate the Ethernet port.

It would be nice to have a couple of unswitched or switched 120v receptacles on the outside of the box to plug my modem and similar devices right in with the CPU. A piano hinge on the expansion Q-bus would be good, so if I have a service loop on the module cables, I could swing the module chassis out to one side to avoid access from the back.

Some of the sheet metal parts of the cabinet didn't fit together well, which made removing and replacing the side panels an ordeal. Still, there's something about a nearly empty backplane and three empty disk cavities that make one's heart glad, and the performance from our new disk and ESDI controller is outstanding. Typical disk-intensive operations, such as system startup and log in, have been reduced in elapsed time by about 30 percent. Disk-bound operations, such as certain sorts, have been improved even more.

CompuServe Data's 1032/AF

Evan Birkhead Getting even thinner is the thin line

that separates the leading-edge methods of application development (i.e., CASE systems and fourth-generation languages). As the software evolution forges ahead, both techniques are converging on a common goal and methodology. They also have in common the quantity and complexity of code they can produce with a few keystrokes. The code that underpins some of these applications, which appears clean and simple from the top, is staggering.

1032/Application Facility (AF), from CompuServe Data of Cambridge, Massachusetts, is an add-on code generation module for software developers using the 1032 4GL/DBMS, which exemplifies this software evolution. The chaotic coding tasks that AF performs behind the scenes go unnoticed by the developer, except for some waiting.

Although not designed for high-volume transaction processing applications (CompuServe Data has higher performance systems for that), AF is a sensible answer for many end users, especially those with an aversion to SQL-style languages, those already running existing 1032 applications or those trying to increase the functionality of current applications written in COBOL, FORTRAN, C and other 3GL VAX languages.

If you understand application design logic, learning AF will be a

"It's easy looking at you, kid."



Introducing the
DEC-compatible
2025.

A new screen star is born—the ADDS 2025.

This is the screen that dreams are made of—the DEC-compatible ADDS 2025. Its unique 70 Hz refresh display gives a stunning flicker-free performance. Along with its dual host capability that can run 2 VT-100 sessions simultaneously, you can connect to other non-DEC hosts, supporting multiple ASCII emulations.

And you'll appreciate our supporting cast of easy-to-read, double high and double high/wide characters; a 44-line display; a choice of 80 or 132 column format and a 14" flat green, amber or page white screen.

The 2025 also gives you brains behind the

The person pictured above is a celebrity look-alike. The estate has not authorized or approved the use of look-alikes.

beauty. With value-added features like 22 fully programmable function keys and 256 bytes of non-volatile memory that help distinguish your product from the competition.

Screen test an ADDS 2025 today. It could be the start of a beautiful relationship.

For more information call 1-800-622-2070.

ADDS

Applied Digital Data Systems Inc.
A Subsidiary of NCR Corporation

100 Marcus Blvd., Hauppauge, N.Y. 11788



CIRCLE 267 ON READER CARD



BASEBALL	DEFINE OR MODIFY APPLICATION COMPONENTS	FR__MODIFY MAINTENANCE
1 __ Define dataset 2 __ Import dataset from System 1032 3 __ Modify dataset 4 __ Define default forms, frames and menu items 5 __ Define form 6 __ Import form from System 1032 7 __ Modify form 8 __ Define frame 9 __ Modify frame		
Select choice and press ENTER: ■		

Screen 1: The key development menu. This is choice 4 on the main AF menu, Screen 3.

P A R K S		
Team Name RED SOX	Grass T	Left 315
Team Code 2	Dome F	Center 390
	Home Field Value 335.00	Right 302
S T A T S		
PLAYER_ID 2951		
PLAYER		
First Name Wade	Last Name BOGGS	
TEAM_ID 2		
TEAM		
Team City Boston	Team Name Red Sox	
Evan Rating		46.12
Games 147	At Bats 551	Runs 108
Total Hits 200	Doubles 40	Triples 6
Batting Average .361	RBI's 89	Home Runs 24
Sacrifice Hits 1	Sacrifice Flies 8	Stolen Bases 1
Out Stealing 3	Walks 105	Intentional Walks 16
Hit By Pitch 2	Strikeouts 48	Grounded Into DP's 13
STATS		
Previous Update	Next Add	Select View
Recompute Evan Rating	Delete	Copy
	Return	Drop
^v Viewing STATS__FORM ... Type <ENTER> to return to menu		

Screen 2: The View option allows a user in the Parks database to access the Stats database and see all factors simultaneously.

breeze. It can be described as a hierarchical screen-based environment that automatically generates code for application components that the developer builds using a logical series of menus and windows. These components are:

1. Dataset — Contains attributes and a single name with no procedures.
2. Form — A set of fields for data display and input, usually associated with a dataset.
3. Frame — An application component associating a form with a menu of options that can be selected by the user while viewing the form. There may be several frames defined for the same form.
4. Menu — A list of options to select.

In a few days, I caught on to the pattern for adding and modifying components:

1. Define datasets, create data fields and lay them onto a form.
2. Set field validations and help prompts.
3. Write procedures and formulas if necessary.
4. Embellish the application by establishing links between disparate data screens or adding option buttons; e.g., AF lets you add Mail.
5. Design menus and report procedures.
6. Hit Build. This command (which, I found is most often used to rebuild) is AF's most prodigious function.

The documentation follows this same development progression. The three-ring booklet describes every menu option encountered when editing datasets, forms, frames, menus and custom-written procedures, in that order.

Building An Application

To test AF thoroughly, I tried to develop an application that would use every AF facet and push some of CompuServe Data's claims to the limit. It easily could

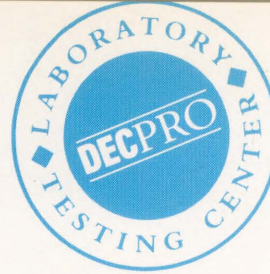

implement data from outside databases, and generated applications could be tweaked easily using editors and other facilities in 1032 and in 1032/AF.

The application, called Baseball, used a database of complete 1987 American League batting statistics (331 records) that was downloaded from Stats Inc. in St. Louis, Missouri, an authorized major league record keeper. It also used a database of variables for the 14 American League ball parks that I entered into AF manually. I wanted the completed application to be used to update records during the season and to generate descending lists of current leaders in any statistical category.

Player datasets from Stats were defined interactively with menu options (see Screen 1). Without guidance, AF set up screens for each record that boxed First Name with Last Name and Team City with Team Name, and set up nice, clean tables for the numerical statistics. I then added an attribute called Team Code (Baltimore 1, Boston 2, etc.) to link the ball park data with the data from Stats. By typing the desired Team Code in a blank Parks form, you get the statistics of that ball park. Choosing the View option lets you pull Stats data for each player who plays in that ballpark, in alphabetical order (see Screen 2).

The forms options (see Screen 1) prompted me to design the Parks table. I added and validated fields for grass surfaces (T/F); domed stadia (T/F); distances to the left, center and right field fences (integers); and a computed average of these distances called Home Field Value. AF also invited me to write help messages to explain each field.

The Parks statistics were used to adjust an involved formula named the Evan Rating, which manipulated almost every stat from each player's record to determine his overall offensive value. Players playing in home parks with close outfield fences or climate-

BASEBALL	DEFINE OR MODIFY APPLICATION	SELECT__APPL 1032/AF
	1 __ Define application header 2 __ Modify current application header 3 __ Select existing application 4 __ Define or modify application components 5 __ Modify application menus 6 __ Build application or components 7 __ Delete application or components 8 __ Make dictionary reports 9 __ Use 1032/AF utilities	
Select choice and press ENTER:		
MENU OPTION	System 1032	Help
	Top Menu	Exit to VMS
Select menu option or <CTRL-Z> to return to main menu; "?" for help		

Screen 3: From this menu, CTRL-Z pushes the developer to interactive 1032, online help, the top AF menu or the \$ prompt.

BASEBALL	baseball formulas
1 __ Home Ballpark Statistics	Frame
2 __ Ballplayer Statistics	Frame
R E P O R T S	
3 __ Report on Top 10 Rated Players	Trim
4 __ User Defined Reports	Proc Proc
ADD/EDIT ITEM	
Item Type	PROCEDURE
Item Label	User Defined Reports
Item Code	
Defined By:	METADEMO APR-21-1988
Modified By:	METADEMO APR-21-1988
MODIFY MENUS	Add Item
Resequence	Select Menu
Edit Item	Edit Help
Delete Item	Exit
Move Item	
Enter updated information for menu items	

Screen 4: This is the top menu for the sample application, shown in development mode, with the modification options.

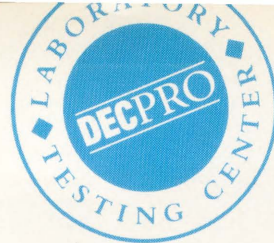

controlled domed ceilings had their home run totals lowered, while those who played on hard artificial surfaces had their base hit totals slightly reduced, etc. (In addition to these weights, the

Evan Rating invokes Boswell's Total Average and James' Runs Created formulas.)

This procedure was written in inter-

active 1032, which automatically invoked EDT. Hitting CTRL-Z lets you follow four paths out of AF (see Screen 3). When the calculation was completed, the whole procedure was pulled back into AF. For this, I had to customize a screen option in the Stats frame that I labeled Recompute Evan Rating. I then sequenced this option with the other user options automatically generated by AF (see Screen 2).

With the two databases and mathematical formulas in place, I added a prominent Evan Rating field on the Stats form. Each player's rating automatically appeared when his screen appeared. (The Red Sox's Wade Boggs and the Brewer's Paul Molitor rated highest.)

User-Defined Reports

To make this application more useful, I needed to allow the user to generate customized statistical reports. In AF, report procedures are part of the Menu Editor (see Screen 4). From the top development menu, I selected "Modify application menu" rather than "Define or modify application components," which I'd been using (see Screen 3). From here, AF let me choose from these

options: Procedure, Frame, Menu or Trim.

The menu had assigned default names to the two databases, which were edited. Using the Trim facility, I designed a Reports heading for the two reporting options I wanted.

Add Item and Edit Item (see Screen 4) let me design the reports. The level of customization I wanted in the reports pulled me to EDT to write the procedure. Editing in EDT functioned differently in AF than it did in the earlier interactive 1032.

I selected "Build application or components." Fortunately, when AF can't build, it stops and tells you what obstacle prevented it from building. Every time it stopped, the problem turned out to be errors in the procedures I had written. In interactive 1032, EDT immediately had notified me when I made coding errors.

Throughout the whole process, AF's logically organized screens and easy way of using windows prevented me from getting lost. For example, when editing Stats frames, the Define/Modify Frame information layer remained at the top of the screen. I then selected a frame option (e.g., Select) and a frame editing procedure (e.g., Edit Option). Information on the Select option appeared in the middle of the screen, and a new Option Edit Menu appeared at the bottom.

Also, the way the application screens are layered, AF was flexible about letting me design some components from the top down and others from the bottom up, depending on the quirks of my procedures.

The Future Of AF

With V7 of 1032, due July 1, a host of new features will be added. Among

these will be V1.1 of AF, which initially was introduced in March. The new version will have no significant functional upgrades over V1.0, which was reviewed for this article. But, V1.5, expected at the end of the calendar year, will have three major additional features: improved text attributes, a better screen painter and improved field level validations. An import/export facility that pushes and pulls data from one dictionary to another also will be in 1.5, and a few underlying data definitional and maintenance things will be updated to support the additions to 1032 V7.

Cipher F880-1 Microstreamer

David W. Bynon

In this age of gigabyte tape cartridges, worm disks and volume shadowing, the half-inch reel-to-reel tape drive quickly is becoming a dinosaur. So why would I be doing a lab on such a beast? Because we still have the issue of compatibility.

If compatibility is the only reason to have a reel-to-reel tape drive, it seems obvious to me that a small, light-duty drive would fill the bill. I bring to you the Cipher F880 Microstreamer.

I purchased the F880-1 Microstreamer for no other reason than compatibility. In fact, the only time the machine gets turned on is when I need to install software or transfer data.

The Cipher F880 is a compact, front-load, microprocessor controller, multispeed magnetic tape subsystem designed to be used as a streamer. In some applications, it also may replace a start/stop drive. It was constructed to be

1032/Application Facility

CompuServe Data Technologies
1000 Massachusetts Ave.
Cambridge, MA 02138
(617) 661-9440

Price range: \$600 for a VAXSTATION license to \$24,000 for a VAX 8800 license. The basic System 1032 license price ranges from \$3,000 to \$120,000.

CIRCLE 520 ON READER CARD

**"I need
unattended
back-ups
now..."**



Jerry Gulden
President
Real-Share, Inc.

...I was desperate for a high-density back-up system. I've got daily back-ups requiring 30 GCR tapes. They are critical to me and my clients. So, I researched various vendors, and SUMMUS provided the complete solution. The **GigaTape** drive fits my needs — and the comprehensive support has been as impressive as the performance of the drive."

At SUMMUS, we know that you can't afford to take corporate computing decisions lightly. Years of experience in customer system integration for special applications end users, OEMs and VARs have taught us that delivering the most value in an integrated product means more than just bolting iron together.

It's easy for us to talk about the SUMMUS commitment to quality, technology, and value. It's easy to say that we provide the right solutions for your high-performance computing needs. It's easy because it's true. That's why Real-Share, Lockheed, Kraft, General Electric, NASA and others have come to SUMMUS for solutions.

**2.33 Gigabyte
Unattended Back-up**

GigaTape™

Our newest product can put this commitment and expertise to work for you, saving you hundreds of hours and thousands of dollars in annual operator and media costs with its high-capacity performance.

Featuring advanced 8mm helical-scan technology, the **GigaTape** is fast, accurate, and reliable. TMSCP compatible with DEC systems, the **GigaTape** will soon be available for IBM, Apple, Sun and other systems.

Ready for delivery with One-Year Warranty — and 30-day return privilege. A full range of maintenance support options is available through our award-winning National Support Group.



CIRCLE 160 ON READER CARD

For more information call us today at 1-800-255-9638.

SUMMUS™
COMPUTER SYSTEMS

SUMMUS COMPUTER SYSTEMS
P.O. BOX 820549 • HOUSTON, TEXAS 77282-0549
713-589-9772 • TELEX 62045352 Answer back SCSSUM • FAX 713-496-1681
Call for our representatives in Canada, France, W. Germany, and the U.K.

© SUMMUS COMPUTER SYSTEMS, 1988
SUMMUS, GIGATAPE, and GIGABOX are TradeMarks of Summus Computer Systems
DEC™ Digital Equipment Corp., IBM™ International Business Machines Corp., Apple™ Apple Computer, Inc., Sun™ Sun Microsystems



mounted inside a 19-inch rack but works equally well as a tabletop unit. If required, Cipher builds an inexpensive tabletop enclosure that's hinged in the middle for easy access to the drive.

The F880 is available in two model versions: F880 Microstreamer and F880 Microstreamer 2. The fundamental difference between the two is their data rates. The Microstreamer 2 will read and write 1600/3200 bpi tapes, while the Microstreamer only will process 1600 bpi tapes. The Microstreamer may be upgraded to the Microstreamer 2. Both drives stream at rates up to 100 inches per second at 1600 bpi. Tape reading and writing is performed in PE format (1600 bpi), which meets ANSI standard X3.39-1973 requirements for data interchange.

The F880 is built on a simple design, which is good because there are

fewer things that can go wrong. The drive's interface (which conforms to the standard Pertec format), logic and software are housed on a single printed circuit board. Further simplifying the drive are the two direct drive DC motors that drive the tape reels.

The Microstreamer self-loads tapes (7-, 8½- and 10½-inch) through the use of an optical tachometer. The tape is blown, in a series of small steps, to the take-up reel; optical sensors are used to release more tape as it moves along its path. When loaded, tape tension is maintained by a single tensioning arm.

Operation of the drive is a simple matter of tossing a tape on the spindle, closing the door and pressing the load button. I've tried both 7- and 10½-inch reels in the drive. Occasionally, the drive will have a load failure, but it never has refused to load a tape, even when the tip

F880-1 Microstreamer

Cipher Data Products
10225 Willow Creek Rd.
San Diego, CA 92131
(619) 578-9108
Price: \$4,000

CIRCLE 558 ON READER CARD

was not prepared.

The only problem I've experienced with the drive is a broken door. Someone in the office tried to open the door (with a heavy hand) before the tape was unloaded. The problem could have been prevented by installing a better interlock latch or a warning light.

The F880 is easy to service. Cleaning the heads, for instance, is a matter of pulling the drive out on its slides and lifting the top cover. The heads then may be swabbed with cleaning fluid. The drive is hinged in the middle for maintenance access to the drive electronics or motors.

The most attractive feature of this drive is its price. I shopped by phone for two days and was amused by the quoted prices. They ranged from \$2,000 - \$4,000. A local distributor gave me a package deal for \$2,450: F880 Microstreamer, tabletop cabinet, cables and a 90-day on-site warranty.

Controllers for the F880 Microstreamer are available from OEMs, such as DILOG, MTI and Emulex. Simply ask for tape controllers that support the Pertec format and use the TSDRIVER supplied with VMS. Controller prices range from \$650 - \$1,200.

Finally, the clincher. This is the same drive that DEC uses in its TSV05 tape drive system; the only difference is the color of the front panel. DEC's basic TSV05 package is equipped with the Cipher F880 Microstreamer, cables and a DILOG controller; the price, a mere \$11,760.

DEC must be paying a lot for its controllers.

File Edit Baud Settings Phone Emulation Commands

Date: (Col: 5 Row: 6) F (G) [2,6] - 2

Header Plot Form Range Window Grid Order Title Subt Labels Heading Axis Name Quit

	1	2	3	4	5	6	7
	Homers	Miers	Children	Cats	Dogs		
Nikes	23	15	16.2	16.2	21	13	
Reebok's	17.2	17	9.35	9.35	15.2	15	
Pro-Keds	12.5	23	9	9	10.5	21	
Dr. Brooks	24	25	13	13	22	23	
Converse	19	33	21	21	15	31	
Pro-Keds	33	35	23	23	31	33	

Mac to VAX

Terminal Emulation/ Communications Software for the Macintosh™

Example 20/20™ session using Tektronix 4105 emulation.

™ Access Technologies

VersaTerm™

Version 3.20 Price: \$ 99.00

DEC VT100/102, DG D200, Tek 4014 emulation. Kermit, XModem and YModem protocols.

VersaTerm-PRO™

Version 2.20 Price: \$ 295.00

Vector-oriented, Tektronix 4105 color graphics emulation... in addition to all the features of standard VersaTerm 3.2.

KaleidaGraph™

Version 1.00 Price: \$ 179.00

A Data Analysis and Graphics Application for Business, Engineering and Science.

TekPrint™

Version 2.00 Price: \$ 79.00

Utility that supports Hewlett Packard 7470 and 7475 Pen Plotters.

• All Programs are Macintosh II and SE Compatible. • All Programs Utilize Color on the Mac II.

• VersaTerm, VersaTerm-PRO and TekPrint Execute in the Background with the MultiFinder!

• VersaTerm-PRO and KaleidaGraph Make Use of Big Screen Monitors.

Designed for a 512K Mac, Mac-XL, 512E Mac, Mac Plus, Macintosh SE and Macintosh II. All Support the ImageWriter(I & II) and LaserWriter printer.

The following are trademarks: Macintosh, AppleTalk, MultiFinder, ImageWriter, LaserWriter - Apple Computer Inc.; Tektronix - Tektronix Inc.; DEC, VAX, VT100 - Digital Equipment Corp.; DG, D200 - Data General Corp.; AlisaTalk - Alisa Systems; VersaTerm, VersaTerm-PRO, TekPrint, KaleidaGraph - Abelbeck Software

Published and Distributed by:

PCS Inc.
2457 Perkiomen Avenue
Reading, PA 19606
(215) 779-0522

Developed by:



DISKIT
2000

ONLINE DISK OPTIMIZATION FOR VMS PROFESSIONALS

Diskit 2000 is engineered for discriminating VMS professionals, the pros who demand perfection.

Why Settle for Just Online

Sure, Diskit 2000 delivers convenient, transparent online operation. Sometimes, that's just not enough. So, Diskit 2000 also includes a specially designed offline program to restructure system files and create perfect disks.

Fully Automatic or Absolute Control

The option is yours. Of course Diskit 2000 provides automatic optimization. It'll consolidate free space for faster file creation, automatically place directories to minimize head movement, and multi-stream data for faster operation. More important, Diskit 2000 provides an interactive graphic display to monitor disk optimization and all the options you need to maximize disk performance.

Designed to Meet Tomorrow's Needs

Diskit 2000's power is impressive and obvious. A VMS professional will really appreciate its sophistication and depth.

Diskit 2000 will impress you today, but you'll really appreciate our careful engineering tomorrow — like our ability to safely handle hidden file accesses or to erase free space for complete security.

Get the Complete Story

DEC customers can count on Software Techniques for quality system software and solid advice. Call on us now for complete information on Diskit 2000.

(800) 332-8650

We'll rush you detailed information on Diskit 2000 and our other VAX/VMS system management software. From Software Techniques — where being first is a tradition.

Software Techniques Inc.,
6600 Katella Avenue,
Cypress,
California 90630 USA
Telephone (714) 895 1633
Telex 701331



Distributors of UIS Software in the USA.

VAX, VMS, and Cluster are trademarks of Digital Equipment Corporation. Diskit is a trademark of Software Techniques, Inc.

Full Featured Dual Mode:

- Online Restructuring Transparent to All Users
- Offline Restructuring for Perfect Disks including System Files

Maximum Compression

- Restructures All Files — even Multi-Header
- Consolidates Free Space
- Multiple Disk Operation

Absolute Data Integrity

- Detects Bad Disk Structures and Shuts down Automatically
- Full Automatic Recovery from System Interruptions
- Data Maintained on Disk at All Times
- Checks All File Accesses — Even NOLOCK
- Safe on Clusters
- Label Check to Intercept Operator Error

Maximum Flexibility

- Automatic or User Defined Directory Placement
- Optional User Defined File Placement For Faster Access
- Automatic or User Defined Free Space Placement
- Adapts to Your Site Environment

Easy Operation

- Doesn't Lock Out Users
- Suspends and Restarts to Work Within System Load
- Built in Scheduler
- Instant Reports

CIRCLE 269 ON READER CARD

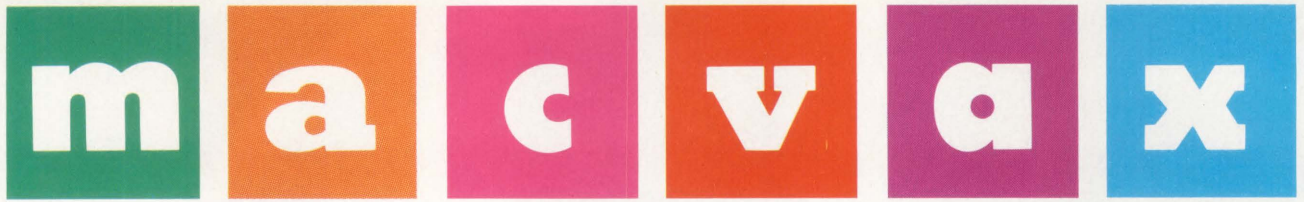

White Pine's Reggie

Double-reverse terminal emulation.

BY EVAN BIRKHEAD

THERE'S NO SUCH THING as a typical Reggie user. Anyone who needs to link Macintosh graphics with VAX applications should be able to find room in the shop for this inexpensive (\$149) conversion package from White Pine Software Inc. of Amherst, New Hampshire. In just a year and a half, Reggie has uncovered a diverse user base that spans applications in CAD/CAM, electronic publishing, graphics presentation and videotext. In short, it has a potential role in either classic Mac or VAX houses.

Reggie completes the third leg of

a file management/terminal emulation triangle that has been assembled by White Pine. The first side of the triangle is the Mac220 and Mac240 series VT emulators. (The Mac240

supports ReGIS and Tektronix 4010/4014 terminals.) The second is VMacS, a file transfer program that converts MacWrite, etc., into VMS formats and catalogs files on the VAX.

Reggie Version 1.1

White Pine Software Inc.
94 Rte. 101A
P.O. Box 1108
Amherst, NH 03031
(603) 886-9050
Price: \$149

CIRCLE 570 ON READER CARD

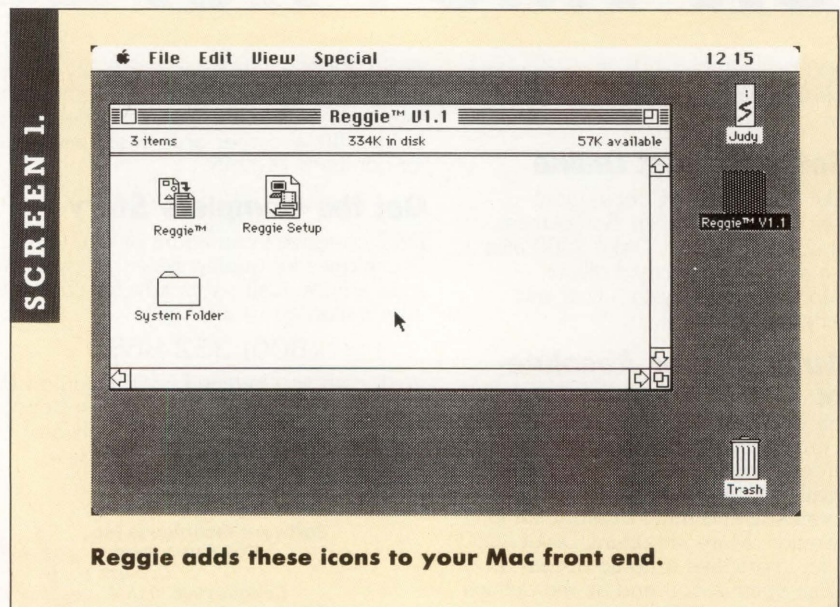

ReGIS is object oriented, and SIXEL is bit-mapped.

VMacS runs with either Mac240 or MacTerminal, but each White Pine system basically is designed to be a standalone tool that complements the others.

ReGIS OR SIXEL

Reggie converts Macintosh graphics instructions into either ReGIS (the root of its name) or SIXEL instructions. Graphics that you designed on the Mac then are shipped into VAX/VMS applications and displayed on your VT-compatible terminal or printed out on your DEC printer. Although this doesn't sound extravagant on the surface, remember that Reggie is dealing with two different worlds: ReGIS is object oriented, and SIXEL is bit-mapped. Underneath, Reggie is performing powerful code conversions.

With a minimum number of selection windows and prompts, Reggie can open pictures from MacDraw, MacPaint or PICT files, which can be object oriented. It can open any arbitrary file that it sees as a resource file, or take drawings directly from the Mac clipboard. Then, it converts the color and resolution into output that can be understood by DEC equipment.

Colors are added one at a time; i.e., individual colors are selected for each object in a MacDraw document and converted into the closest cor-

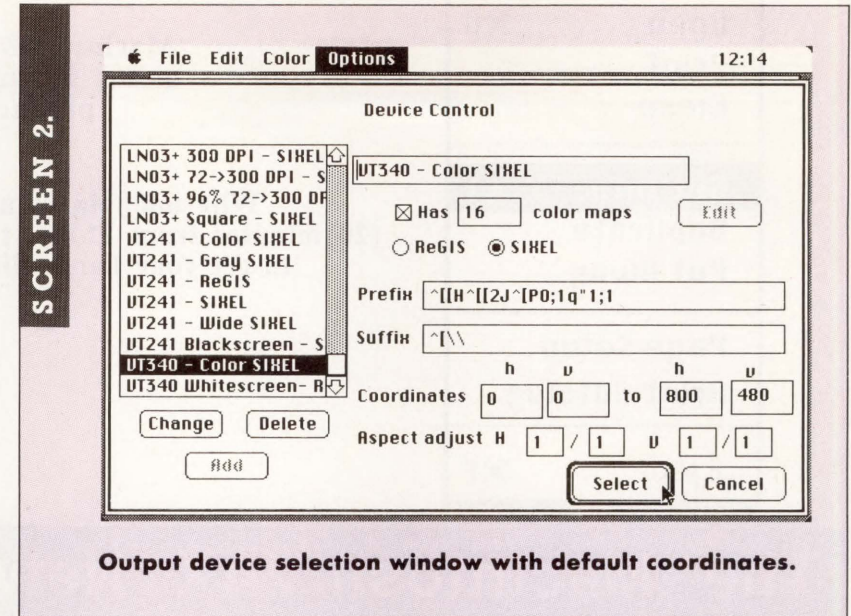

Output device selection window with default coordinates.

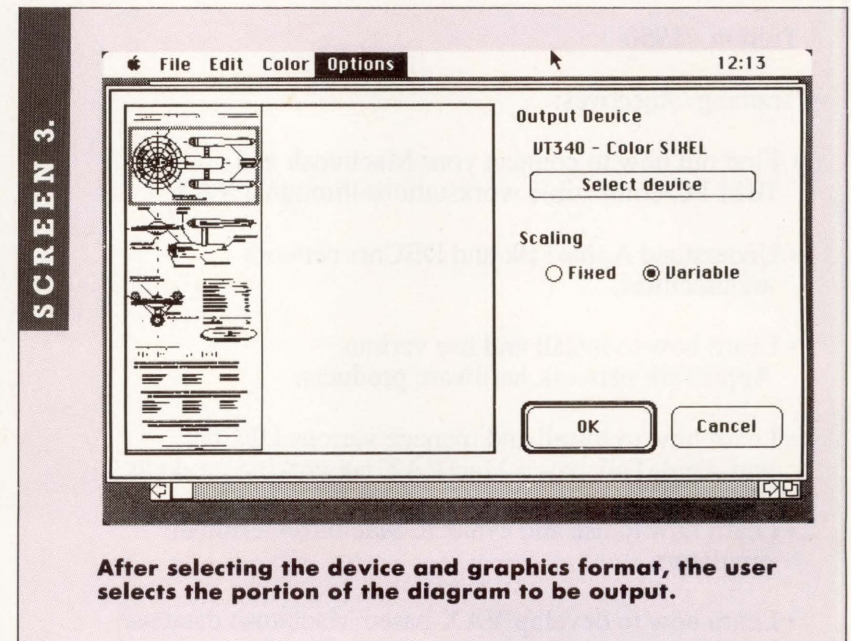

After selecting the device and graphics format, the user selects the portion of the diagram to be output.

responding color at the other end. Some beautifully colored, high-resolution Mac II pictures came across on the terminal as the best color and highest resolution that each DEC machine (printer or terminal) could muster. It was fun watching them try to match up.

Reggie can deal with large draw-

ings. When selecting the output device (see Screen 3), a mouse-controlled frame lets you define a portion of the drawing you want sent. The program takes advantage of several nice Mac OS gizmos like this. For instance, when sending drawings, charts track the progress of conversion development and buffer space.

File Edit View Special

Confused?

New Folder
Open ⌘O
Print
Close

Get Info ⌘I

Duplicate
Put Away

Page Setup...
Print Catalog...

Eject ⌘E

No wonder.

Macintosh®-VAX/VMS™ Networking
means a dizzying array of connectivity
products, network architectures,
and hardware options.

Why not join us at our office in Marlton, NJ
(20 minutes from Philly, two hours from New York)
to get your hands dirty and your head straight:

June 13-15, 1988 •
July 6-8, 1988 •
August 1-3, 1988 •
September 7-9, 1988 •

The Macintosh/VAX Networking Lab

Course length - 3 days

Tuition - \$950

Training Objectives:

- Find out how to connect your Macintosh and IBM PC-compatible workstations through a VAX
- Understand AppleTalk and DECnet network architectures.
- Learn how to install and use various AppleTalk network hardware products.
- Learn how to install and manage various DECnet and AppleTalk based Mac/VAX networking products.
- Learn how to use and evaluate Macintosh terminal emulators.
- Learn how to develop VAX-based Macintosh database applications.

Topics Covered:

- Network Architectures •
DECnet, AppleTalk
- Network Hardware •
Ethernet
LocalTalk
Bridges
Gateways
- Network Management •
- Terminal Emulators •
VT100, VT220, VT240
Tektronix
- VAX/VMS File Servers •
AlisaTalk, PacerShare
- Networked Databases •
- Network Management •



COMPUTER METHODS CORPORATION

525 ROUTE 73 SOUTH • SUITE 300 • MARLTON, NJ 08053
CONSULTING • TRAINING • SOFTWARE ENGINEERING

PHONE (609) 596-4360

FAX (609) 596-4362

Macintosh and AppleTalk are registered trademarks of Apple Computer, Inc.
VAX and VT are registered trademarks of Digital Equipment Corporation.
IBM and IBM PC are registered trademarks of International Business Machines, Inc.

CIRCLE 179 ON READER CARD

Macintosh II to Ethernet, Now.

Speed. Access. Power.
The EtherPort II
from Kinetics.

As always, the best-connected Macintoshes
begin with Kinetics.

The EtherPort II:

- Connects your Macintosh II directly to Ethernet.
- Provides full EtherTalk compatibility.
- Includes Macintosh O/S and A/UX drivers.
- Supports TCP/IP, DECnet, OSI and EtherTalk connections to VAX, UNIX, PC or Macintosh environments.

You can also connect your Macintosh SE to Ethernet with the Kinetics EtherPort SE.

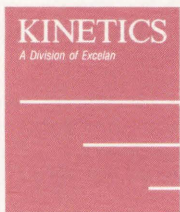

For more information, call 800-433-4608 outside
California, 415-947-0998 in California.

Kinetics, Inc. 2540 Camino Diablo Walnut Creek California 94596

CIRCLE 266 ON READER CARD



Tie All Your Loose Ends Together.

VAX to MAC and IBM PC

Multi-system environments are a way of life. Your Macintoshes and IBM PCs have become powerful tools to use with your VAX system. Now you need Pacer to tie everything together into a seamless package.

PacerLink connects your Macintoshes and IBM PCs to your VAX over serial line, remote modem, AppleTalk or Ethernet configurations. It integrates full functionality into one product: terminal emulation, file transfer, virtual disks, and print services. And you get even more when you extend PacerLink with the add-on file server and graphic terminal emulator.

PacerShare VAX/VMS file server provides Macintosh and IBM PC file sharing via Ethernet or AppleTalk bridged to Ethernet. It transparently integrates the micro and VMS file systems.

PacerGraph gives your micros VT240 and VT241 graphic terminal emulation, including ReGIS and Tektronix 4010/4014 support.

PacerPrint provides VAX PostScript print spooling.

Kinetics hardware combined with Pacer's software gives you high speed Macintosh to host interconnect over Ethernet.

Our connectivity solutions are in place at over 1500 sites. And we want yours to be the next. Give us a call and let us show you how we can integrate your minis and micros into one well-connected package.

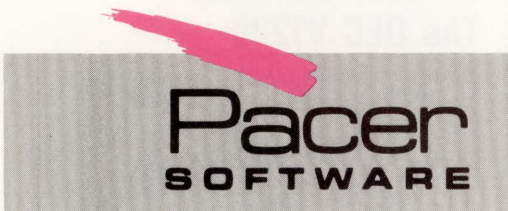

Pacer
SOFTWARE

7911 Herschel Ave., Suite 402 • La Jolla, CA 92037
TEL: 619-454-0565

1900 West Park Drive, Suite 280 • Westborough, MA 01581
TEL: 617-898-3300

CIRCLE 244 ON READER CARD

Trimarchi Slashes RD54 Prices

Trimarchi Inc. has slashed the price of the RD54 equivalent from \$3,495 to \$1,995. Each disk drive has a two-year warranty, 24-hour advanced replacement, 24-hour delivery from stock, testing and formatting, cables, mounting hardware for MicroVAX 2000, engineering assistance and guaranteed DEC field service.

Find out more by contacting Thomas Trimarchi, Ph.D., Trimarchi Inc., P.O. Box 560, State College, PA 16804; (814) 234-5659; FAX: (814) 237-8031.

Circle 400 on reader card

Multisession Support Added To Reflection

Walker Richer & Quinn has enhanced the LAT support included with its Reflection Series of terminal emulation and communication software. Release 3.0 of Reflection 4 PLUS and Reflection 2 PLUS includes Reflection's new multisession capability, similar to that available in DEC terminal servers.

The new LAT support includes commands such as SHOW SESSIONS and SHOW SERVICES to provide information about the host services available. The improved LAT support is included in Reflection 2 and 2 PLUS, Reflection 4 and 4 PLUS, and in Reflection 1 PLUS and 7 PLUS. Support for other networks, such as 3Com and Ungermann-Bass, is included in the PLUS versions of Reflection.

For more information, contact Wendy Sue Williams, Walker Richer & Quinn Inc., 2825 Eastlake Ave. E., Seattle, WA 98102; (206) 324-0350.

Circle 401 on reader card

P3 Upgrade Has Easier Data Entry

Primavera Systems Inc. has announced V3.1 of its flagship product Primavera Project Planner (P3). The upgrade has easier data entry and interchange capabilities. New features

include import capabilities and expanded batch processing. Continuous printed bar charts also are available.

P3 is a comprehensive project management system with the features and flexibility required to manage large and small projects. It interfaces with Primavision for presentation graphics that can be customized to any level of detail. P3 runs on the IBM PC and PS/2 Series and compatibles. It requires a hard drive and 512K.

More information is available by contacting Diane Dempster, Primavera Systems Inc., Two Bala Plaza, Bala Cynwyd, PA 19004; (215) 667-8600.

Circle 402 on reader card

Polygen Software Runs On VAXstation 8000

Polygen's QUANTA and CENTRUM products now are supported on the VAXstation 8000 high-performance 3-D graphics workstations. QUANTA is a 3-D graphics system and operating environment for the visualization of chemical structures and control of numerically intensive simulation software. It incorporates the X Window System, Version 11 windowing and PHIGS+ graphics software standards.

The CENTRUM system automates the process of producing scientific and research documentation in office and laboratory environments.

For further information, contact Ethel Kaiden, Digital Equipment Corporation, Maynard, MA 01754-2571; (617) 467-2347.

Circle 403 on reader card

Version 3.0 Of EDItran Announced

EDI Solutions has announced EDItran version 3.0 (Electronic Data Interchange). Two new features are the ability to operate on the

VAX under VMS and the capability to enter, view and modify partner file records using CICS screens.

EDItran version 3.0 features include support of CICS online partner file maintenance, operates under VAX/VMS system, separation of transactions into multiple output files, enhanced audit reports and support of conditional element validation.

For additional information, contact EDI Solutions Inc., Northwestern Financial Ctr., Ste. 702, 7900 Xerxes Ave. S., Minneapolis, MN 55431; (612) 831-9059.

Circle 404 on reader card

AOK Adds Product Features

AOK Software Products Inc. has announced enhancements to the abc spreadsheet graphics. Spreadsheet users now can develop pie chart images with one of the pie slices offset.

AOK.abc easily is integrated into ALL-IN-1. It then becomes one of the menu items in the ALL-IN-1 environment. Instructions for structuring the abc spreadsheet within ALL-IN-1 require about 10 minutes to execute. Then, users have a familiar spreadsheet tool at their disposal.

Also, a built-in, online tutorial is available to first-time spreadsheet users. A built-in spreadsheet macro now walks the user through the use of spreadsheet fundamentals.

AOK.abc is a Lotus 1-2-3 clone for VAX/VMS users.

Learn more by contacting AOK Software Products Inc., 1305 Wiley Rd., Ste. 102, Schaumburg, IL 60173; (312) 884-7123.

Circle 405 on reader card

GP-220Z Emulates The DEC VT220

Northwest Digital Systems has announced the GP-220Z terminal. It has 290 KB of display list zoom memory that allows the terminal to display zoomed images using smooth lines. Other features include the ability to output alphanumeric and vector commands to hardcopy devices, such as DEC LN03 Plus, resulting in full-size, high-quality hardcopy output.

The GP-220Z offers all the features of the GP-220 terminal including 75 pages of "Off-Screen Text Memory." Eight built-in fonts include the DEC Technical font used in WP programs, such as MASS-11. The terminal also allows convenient text display formats of 80 x 132 columns x 24, 33, 50, or 68 lines.

The GP-220Z is priced at \$1,795.

Find out more by contacting Northwest Digital Systems, Seattle, WA; (206) 524-0014.

Circle 406 on reader card

Raima Releases db__REVISE

Raima Corporation has announced db__REVISE, a database restructuring product for use with the db__VISTA III database development system. Raima's system is written in standard C for system portability and is linkable with most C compiler libraries including DEC C.

A developer can use db__REVISE to

transform an existing database into one that incorporates new record relationships (formed by splitting, combining or creating record types), data field additions or deletions, data typing conversions (character to numeric, integer to floating point and all other combinations), record redistribution across files, creation and deletion of set relationships (parent to child pointers), creation and deletion of keys, and data conversions through developer-supplied routines.

For additional information, contact Mark Hervol, Raima Corp., 3055 112th Ave. N.E., Bellevue, WA 98004; (206) 828-4636; FAX: (206) 828-3131.

Circle 407 on reader card

VAXsimPLUS Maximizes System Availability

DEC has introduced VAXsimPLUS, an AI-based software technology that helps predict potential system failures and prevent system downtime.

The new technology, provided as a standard feature of VAX/VMS system warranty and service contracts, acts as an on-site monitor of DEC systems and storage devices. It continuously tracks system activity and alerts the appropriate personnel to potential problems before a failure or data loss occurs. For RA series hard disks, VAXsimPLUS automatically can copy and protect data on a suspect disk.

VAXsimPLUS runs on all VAX/VMS systems. It's free for all VAX/VMS systems covered by a DEC system warranty or standard service agreement.

Learn more by contacting Nick Houpis, DEC, Maynard, MA 01754-2571; (617) 870-3285.

Circle 408 on reader card

Wollongong Improves TCP/IP Performance

Users of VAX computers now can have the latest in TCP/IP technology and increased performance, with Wollongong's enhanced software data communications product WIN/TCP for VMS. This is the latest member of the WINS (Wollongong Integrated Networking Solutions) family of network operating systems, which support TCP/IP and ISO/OSI protocols on systems ranging from PCs to supercomputers. This version is targeted to VAX/VMS users.

WIN/TCP's advanced performance is provided by the incorporation of leading-edge research technology known as "congestion control." This monitors the performance of the data transmission media, and adjusts the flow of information in order to maximize the network's throughput.

Find out more by contacting Norman Lombino, The Wollongong Group Inc., 1129 San Antonio Rd., Palo Alto, CA 94303; (415) 962-7200.

Circle 409 on reader card

Encore Offers VAX Compatibility Suite

Encore Computer Corporation now offers a VAX Compatibility Suite of software that gives VAX users access to the throughput of Encore's Multimax parallel processing systems, while maintaining a compatible user environment.

The VAX Compatibility Suite includes two modules that interface to UMAX, the UNIX-based operating system of the Multimax. The first module is Encore VCL, a VMS emulator implementing a majority of commands in the DEC command language. Encore EDT+ emulates and implements all the features of the VAX EDT WP system. For VAX FORTRAN users, Encore also offers FORTRAN 77 with VMS extensions.



Raima Corporation's db__VISTA III database development system software.

DILOG Subsystems



The PROBLEM SOLVERS

There's good news. And better news.

You know you can rely on DILOG to solve your controller/coupler problems...over 95,000 in the field. Good news.

Now, DILOG offers subsystems too. Better news. You and your customers can pick from over 350 subsystem combinations...any DILOG controller and peripheral you can think of. All from one source.

ADD-IN SUBSYSTEMS

You need a 5 $\frac{1}{4}$ " disk subsystem or $\frac{1}{4}$ " QIC tape back up with a reliable interface. DILOG Problem Solvers have it... complete in a BA123 or BA23 compatible housing with cables, ready to operate.

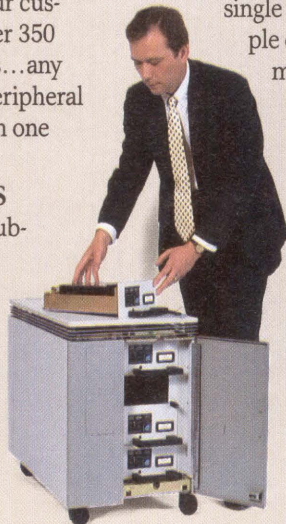

As your subsystem needs get larger, your problems don't. DILOG Problem Solvers offer state-of-the-art interfaces for today's or tomorrow's large capacity disks and high speed tape drives.

ADD-ON SUBSYSTEMS

You need hard disk capacities... single drive from 70 MB to multiple drives with 5 GigaBytes or more. And high speed tape back up. DILOG Problem Solvers have it... popular drives... interfaces... compatible housings... cables... everything.

INSTALLATION

DILOG Problem Solvers can help you install your subsystem, interface your computer system or run diagnostics tests... everything. Staff personnel world-wide make it easy.

SERVICE

Even after installation the DILOG Problem Solvers can handle service... subsystems or the complete system. Again, you can rely on DILOG's Problem Solvers. Sole source supply. Sole source service. Faster than 3rd party service too.

Subsystems, installation, service... all just a phone call away.

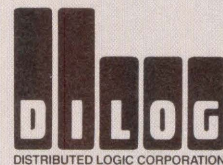

**1-800-DILOG32
(outside Calif.)**

Corporate Headquarters
1555 South Sinclair Street
Anaheim, CA 92806
(714) 937-5700, Telex 6836051
FAX: (714) 978-2420

The Encore Compatibility Suite costs \$10,500.

Find out more by contacting Mary Kae Marinac, Encore Computer Corp., 257 Cedar Hill St., Marlboro, MA 01752; (617) 460-0500.

Circle 411 on reader card

LRT Launches Network Quality Analysis

The British networks company, Logic Replacement Technology (LRT), has an Ethernet network management system that prevents network downtime by measuring the quality of the network through previously unmeasured parameters and alerting the manager to potential problems before they become serious.

The Network Quality Analyser (NQA) combines digital signal measurement with highly usable data presentation techniques to identify network degradation that's often hidden from the user by the compensating effect of network protocols.

All signal measurement and test functions are conducted without interfering with network traffic so that the network remains live at all times.

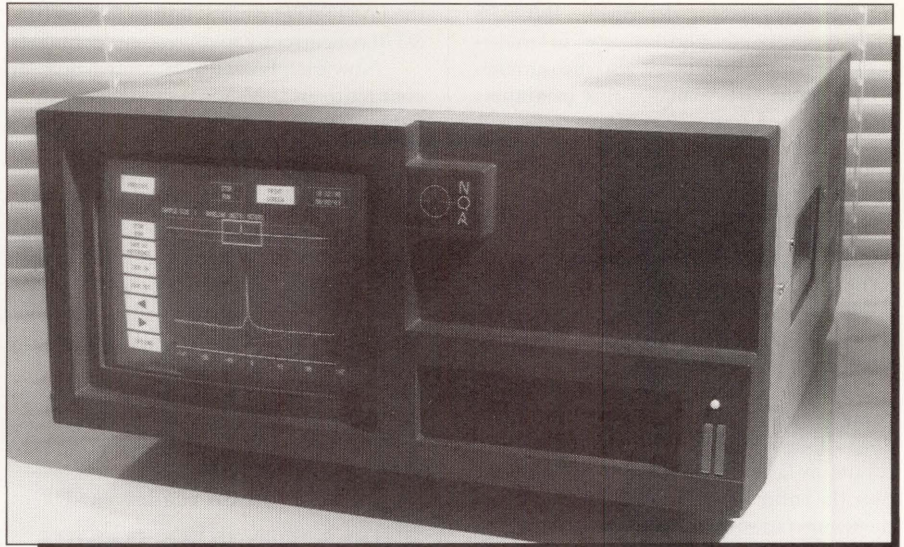

The Network Quality Analyser from Logic Replacement Technology.

More information can be obtained by contacting Robert Barrett, Logic Replacement Technology Ltd., Arkwright Rd., Reading, Berks RG2 0LU; +44 734 311055.

Circle 410 on reader card

INGRES RDBMS Has Multiserver Data Manager

Relational Technology Inc. now is shipping Release 6 of the INGRES relational database



Comptrol at Your Fingertips

Imagine the touch of a key providing a manager with control of his business. We at **Compu-Share** call such control "comptrol" and offer it to you in our "**Business Comptrol Series**" of VAX accounting software. Now you can design your own financial statements showing virtually any comparison you might want; project your cash requirements for the next 90 days; analyze which vendor has the best delivery and terms record; or compare each of your division's profits over the last three quarters. The **Business Comptrol Series** does all this and much more. After all, the Series has been built on the principle that a computer system should afford you

control of your company—rather than the computer controlling you. Our software is fully **interactive**, checking for mistakes, providing information, and updating files instantaneously. Our **customer service** department is just as responsive, giving you the help you need, when you need it. Thorough training services equip your personnel to easily handle the system. Isn't it time you took "Comptrol"? Join the hundreds of other companies who have upgraded to the **Compu-Share Business Comptrol Series**, which includes GL, AP, PO, PR, AR, OE, IC, and FA. Call today to speak with one of our consultants. **Comptrol** is right at your fingertips!

Compu-Share
Business Accounting Software

(806) 794-1400
5214 68th Street Lubbock, Texas 79424

CIRCLE 241 ON READER CARD

management system (RDBMS). INGRES provides scalable performance in multiprocessor environments. It also incorporates a multiserver data manager that maximizes the power of leading edge, cost-effective hardware; e.g., the Sequent multiprocessor UNIX system, the VAXcluster and the Polar Star systems.

INGRES Release 6 supports more users, larger databases and fully automated recovery techniques. It provides the high performance required for OLTP and for the complex query processing required by decision-support tools.

Release 6 introduces INGRES TPA, combining Tools, Power and Access to produce a Total Performance Architecture, which results in faster, more productive software over the entire lifecycle of database development, operation and maintenance.

For more information, contact Relational Technology, 1080 Marina Village Pkwy., Alameda, CA 94501-9891; (415) 769-1400.

Circle 413 on reader card

FASTPATH Enhances Its Capabilities

Intel Corporation has enhanced capabilities for its FASTPATH product line that enable

the FASTPATH control unit to link an IBM S/370 concurrently to diverse environments.

Now each FASTPATH control unit can connect to an IBM S/370 simultaneously to a TCP/IP network, as well as to either a VAX, a MAP/OSI network, a custom Ethernet network or to ASCII devices.

A FASTPATH control unit with Flex-LINK connectivity software now can manage simultaneous connections from an IBM S/370 processor to up to four VAXs or to a VAX and TCP/IP network. The connection to the VAX is through the high-speed DR11W/DRB32W interface.

More information is available by contacting Phyllis Stern, Intel Corp., 3065 Bowers Ave., P.O. Box 58065, Santa Clara, CA 95052-8065; (602) 869-3778.

Circle 415 on reader card

Silicon Graphics Debuts The 4D Workgroup

Silicon Graphics Inc. recently introduced a series of products that allow IRIS Superworkstation users to share information, compute cycles, graphic objects and applications wherever those resources reside on the network.

The new products, which comprise the

4D Workgroup, address the three major concerns of a networked environment: network access, distributed graphics objects and resource sharing to distribute compute and storage loads.

4DDN gives users access to applications running on DECnet. It provides a Phase IV, DECnet-compatible node on the network, so users can transfer files, obtain directory listings, exchange data and access other DECnet nodes. 4DDN also provides DECnet management functions.

4DDN also provides VAX/VMS users with access to the UNIX operating system, because they can log in to any IRIS 4D Superworkstation running 4DDN.

To learn more, contact Silicon Graphics Computer Sys., 2011 Stierlin Rd., Mountain View, CA 94043; (415) 960-1980.

Circle 414 on reader card

Aviv Delivers Backup System For MicroVAX

Aviv Corporation's TFS 935D-8200 is a high-density tape storage system for MicroVAX and MicroPDP-11 Q-bus computers. It's based on Exabyte 8mm tape cartridge technology. Up to 2.3 GB of data can be stored at the data rate of 246 KB/sec. on

**For A Full-Featured
Tektronix Graphics Terminal,
Just Add Your PC,
Mac II or Workstation**

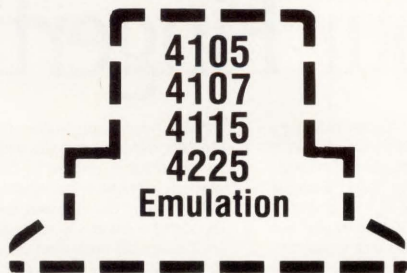

Grafpoint, the technology pacesetter in terminal emulation, offers the broadest range of powerful terminal emulation packages for PCs, PS/2s, Macintosh IIs, and workstations. Grafpoint's emulation products are available for both asynchronous or networking environments.

Grafpoint's devotion to product innovation, compatibility, and customer support makes us the leader in Tektronix emulation. Grafpoint products have a 30-day no-risk guarantee, free updates, and technical support for 1 year. Find out why Grafpoint is the technology leader in Tektronix emulation. Call today for the Grafpoint distributor nearest you: (800) 426-2230, in CA call (408) 446-1919, Grafpoint, 1485 Saratoga Avenue, San Jose, CA 95129.

 **GRAFPOINT™**
CIRCLE 124 ON READER CARD

UNIX *Training*
For the '80s, '90s & Beyond!

UniForum/DC ■ August 2-4, 1988
Washington Hilton & Towers
Washington, D.C.

- 9 in-depth tutorial sessions presenting essential UNIX information.
- 18 condensed symposia exploring additional UNIX features.
- An exhibit floor packed with the latest UNIX hardware & software.

Get the UNIX Answers You Need!

Call **800-323-5155**
for your FREE brochure.



UniForum/DC
2400 East Devon Avenue
Suite 205
Des Plaines, Illinois 60018

CIRCLE 285 ON READER CARD

If you can make it to only *one* U.S. Government computing event this year . . . make it *this one!*

Aerospace & Defense Computing

'88

September
20-22, 1988

The Los Angeles Airport Hilton Hotel
Los Angeles, California

THREE-DAY CONFERENCE AND EXPOSITION

ADC '88 Exposition will feature 100 exhibits from select manufacturers of:

- Supercomputers
- Workstations
- CAD/CAM
- AI/Neural Networks
- ADA
- Graphics/Imaging
- Ruggedized and Fault Tolerant Systems

Manufacturers include:

• H-P • Raytheon • Cray • DEC • Prime • At&T • Sun • Convex • G.E.

ADC '88 Three-day technical conference will feature:

Defense Needs vs. Industry Trends

Bob Cooper
Former Director of DARPA

Coordinated Requirements for Future Systems

Col. Will Stackhouse
Pentagon Asst. for High Leverage Tech
Secretary of the Air Force for Acquisitions

Computing Requirements for the Space Station

Henry Lum
Chief of Information Sciences, NASA/Ames

Fault Tolerant Systems, System Level Architecture

Jay Lala
Draper Labs

CISC vs. RISC

Bill Geideman
Sr. Manager, McDonnell Douglas

Future Bus Structures

Sven Behrendt
CEO, Force Computers

1553 Standard Data Bus for Spacecraft

Capt. Mark Owen
Kirtland AFB Program Manager

High Performance ICs

Pierre Lamond
Co-Founder, National Semi

Digital GaAs Progress

Sven Roosild
DARPA

ADC '88

WHEN!

September 20-22
1988

WHERE!

Los Angeles Hilton Hotel
5711 West Century Blvd.
Los Angeles, CA

NEN

NORM DE NARDI ENTERPRISES
289 So. San Antonio Rd., Suite #204
Los Altos, CA 94022
(415) 941-8440

Attendance to exhibition is free!

- Please send me a complimentary invitation.
- I am interested in exhibiting, please send more info.
- I would like to take advantage of the \$395 pre-registration conference price, check enclosed.

Name _____ Title _____

Company _____ Phone # _____

Address _____

City _____ State _____ Zip _____

cartridges costing \$12.

The system occupies the same form factor as Aviv's 5 1/4-inch disk drives. The combination of rotating heads and moving tape yields a head-to-tape speed equivalent to a 150ips, 1/2-inch, 9-track open reel tape drive and a data transfer rate of 246 KB/sec. Read-After-Write verification and automatic data block rewriting by the drive ensure high reliability while maintaining high data throughput and eliminating time-consuming host intervention and tape repositioning.

The TFC 935D is compatible with DEC software driver TSV05 or TS-11 and with RSX-11, RSTS (V.8.0), TSX-11 Plus, RT-11, ULTRIX, MUMPS, UNIX and VMS operating systems. Up to four drives are supported by the TFC 935D Controller. For further information, contact Aviv Corp., 26 Cummings Park, Woburn, MA 01801; (617) 933-1165; FAX: (617) 938-5691.

Circle 416 on reader card

RA320 Emulates DEC's VT320

Relisys has introduced the Model RA320, which emulates the VT320. It interfaces with

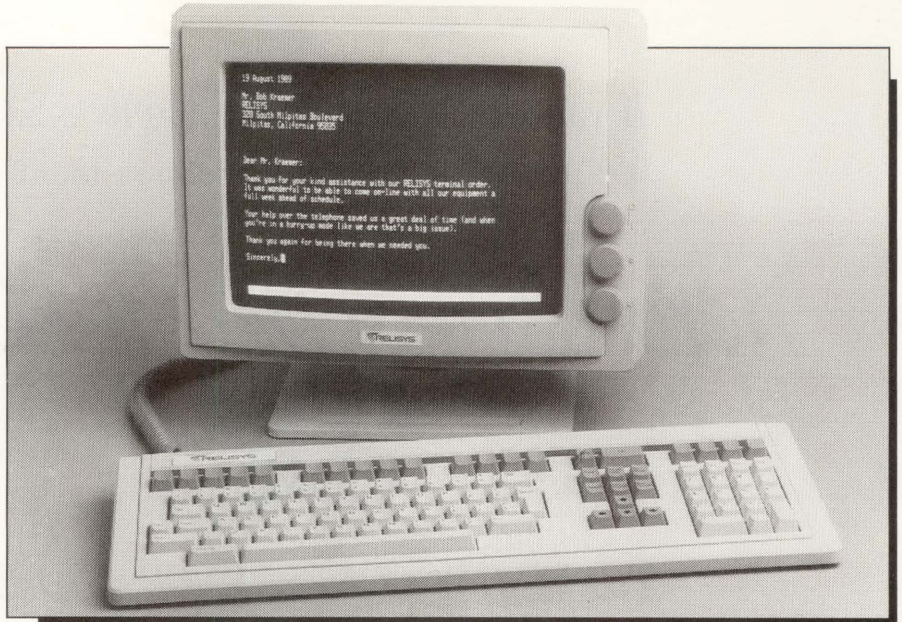

Relisys' Model RA320.

all DEC computers for general-purpose OA data entry use.

Screen character attributes include reverse video, underline, bold, blink, blank,

and double-height, double-width characters, plus split screen, screen saver and menu setup screen.

The unit features a low-profile DEC-

RSX CONSULTING

- M, S, M-PLUS, Micro-RSX
- Performance Analysis/Tuning
- Device Drivers a Specialty
- Call-Up Support Service
- Disk Corruption Recovery

James A. McGlinchey
(Author of "The RSX Clinic")
Software Engineering Consultant
5 Skyline Drive
Post Office Box 81
Essex Junction, VT 05452-0081
802-879-6014

CIRCLE 130 ON READER CARD

C++

FULL COMPILER – not a preprocessor

- Complete software-development system
- Selectable AT&T C++, ANSI C, K&R C
- Based on proven Oregon Software technology
- Generates extremely fast, compact code
- Comprehensive error checking
- Strongly typed language
- Hosted on SUN-3 (VAX in fall of 1988)

DATA ABSTRACTION FACILITY (classes)

- Operator overloading
- Information hiding/sharing
- Constructors/destructors

YES! I want top performance at an affordable price

To order, or for more information, call 1-800-874-8501
6915 SW MACADAM, SUITE 200, PORTLAND, OR 97219

OREGON SOFTWARE

Professional Products for Software Development

CIRCLE 288 ON READER CARD

compatible keyboard and includes 15 programmable function keys, as well as five user-selectable control keys and four LED indicators. All the character attributes, character sets and downline loadable features of the VT320 are included. This includes ASCII, DEC special and supplemental graphics, ISO Latin and National Replacement (NRC). The unit also is compatible with VT52, VT100 and VT220 with ANSI 3.64-compatible control functions.

Find out more information by contacting Relisys, 320 S. Milpitas Blvd., Milpitas, CA 95035; (408) 945-1062; FAX: (408) 945-0587.

Circle 412 on reader card

Performance Upgrade For VAX 11/780 Users

Nemonix Inc. has released the next generation of system expansion products. The upgrade is designed for VAX 11/780 users and increases overall system throughput up to 45 percent.

The upgrade is hardware/software compatible and includes Nemonix micro diagnostics, memory diagnostics, benchmark

software and the customer protection package.

The upgrade is priced at \$29,900, which includes the CPU upgrade and 16 MB of Nemonix memory.

For additional information, contact Ken Burdulis, Nemonix Inc., 106 South St., Hopkinton, MA 01748; (617) 435-9087.

Circle 417 on reader card

VMS Tuning Guide Released

Touch Technologies Inc. has released a tuning guide for VAX system managers and operators. The *VMS Tuning Guide* was written in response to many requests for insight and information on VAX/VMS tuning. It provides information about VMS SYSGEN parameters and attempts to standardize tuning methodologies. TTI assumes that the reader is already familiar with the VMS SYSGEN and VMS AUTHORIZE utility.

The *VMS Tuning Guide* explains that "... the purpose of tuning is to get maximum benefit from existing hardware. Tuning is not a way of life. It is the last step before acquiring new hardware."

Interested VAX users can obtain a copy of *VMS Tuning Guide* free by contacting Touch Technologies Inc., 9990 Mesa Rim Rd., Ste. 220, San Diego, CA 92121; (800) 525-2527; in California (800) 325-2527; outside U.S. (619) 455-7404.

Circle 419 on reader card

Box Office Tracks VAX/VMS Software Access

Owen + Davis Systems Inc. has introduced a utility called Box Office, which lets VAX/VMS software developers license their products by user. This product tracks the number of people using a software application program and prevents user access beyond a predetermined limit set by the software developer. It also allows VMS software developers to compete with PCs on a cost-per-user basis, while ensuring that software licensed for a single CPU can't be copied across an entire VAXcluster and used by multiple CPUs.

Box Office continues to operate correctly even if the program being protected crashes or is interrupted.

The Box Office user-tracking system

Build Your Own Mainframe Computer System For Under \$8K!

Recipe: Start with one PC-386/286 computer running PC/MS-DOS and/or SCO Zenix,*
Add one or two of your own SMD disk drives,
Add one SMD disk controller for PC-286 bus (we provide),
Format each disk drive up to 512MB/volume in DOS,
Add our PC/MS-DOS or Zenix software disk driver for the drives.

Load: Software disk driver with formatter/partitioner on diskette media.

Modify: Config.sys file and reboot.

Voila! You now have a micro computer system that looks like a minicomputer and possesses the power, reliability and properties of a mainframe.

For further information, contact:

UPPER BOUND MICRO COMPUTERS, INC.

18 Elizabeth Street
West Conshohocken, PA 19428



Phone: 215-825-0505
FAX: 215-828-8618

*PC-DOS is a registered trademark of IBM; MS-DOS and Zenix are registered trademarks of Microsoft Corp.; SCO is a trademark of The Santa Cruz Operation, Inc.

CIRCLE 187 ON READER CARD

has a one-time price of \$695 and operates on all VAX systems.

Learn more by contacting Matthew Owen, Owen + Davis Sys., 3100 Airway Ave., Ste. 116, Costa Mesa, CA 92626; (714) 540-8878.

Circle 418 on reader card

8-, 16-, 32-MB Memory Now From Clearpoint

A new MicroVAX and VAXstation 3XXX-compatible memory series consisting of 8-, 16- and 32-MB boards has been announced by Clearpoint Research Corporation. Using a custom gate array design, Clearpoint's MV3000 delivers 32 or 16 MB of memory using state-of-the-art one megabit DRAMs.

The MV3000/8 MB uses 256 Kbit ZIP DRAMs. It also can be used by MicroVAX II customers who upgrade their MicroVAX II CPU boards to the MicroVAX 3000.

The MV3000 comes with an unconditional lifetime warranty and a 24-hour before-repair/replacement policy.

For more information about this series, contact Greely Summers, Clearpoint Research Corp., 99 South St., Hopkinton, MA 01748-2204; (617) 435-6184.

Circle 420 on reader card

Cisco Systems Announces Hybrid Bridge/Router

Cisco Systems Inc. has announced its first bridging product, the HyBridge, a hybrid bridge/router for internetworking. HyBridge combines the functionality of Cisco's Level-3 router with that of a MAC-layer bridge (media access control at Level-2 of the OSI protocol stack).

This product is a full-performance network-level router that simultaneously provides the ability to fall back to bridging functions in specified cases. The HyBridge provides DECnet users with true interoperability — the HyBridge router allows DECnet to interoperate with TCP/IP and other protocols, while the bridge can handle the DEC's proprietary LAT packets. To the user, this all occurs transparently.

HyBridge is priced from \$6,200.

Learn more information by contacting William R. Graves, Cisco Systems Inc., 1360 Willow Rd., Menlo Park, CA 94025; (415) 326-1941.

Circle 421 on reader card

Eikonix Introduces New Desktop Slide Scanner

Eikonix Corporation has announced the EIKONIX 1435 Slide Scanner. This small-format digitizer is tailored for high-throughput scanning of 35mm mounted and unmounted slides, negatives, single frames

and film strips, 35mm sections of 70mm film and aperture cards.

The high-performance scanner completes a color scan in less than three minutes and has 2800-dpi resolution with a dynamic range of up to 12 bits per pixel per color. It is suited for applications such as advertising, presentation graphics, desktop publishing, photojournalism, printing and publishing.

The new Eikonix family of digital imaging cameras supports a variety of computer buses and systems including IEEE-488, UNIBUS and Macintosh II PCs.

If interested in obtaining more information, contact Eikonix Corp., 23 Crosby Dr., Bedford, MA 01730; (617) 275-5070.

Circle 422 on reader card

Double Announcement From MegaTape

Two new backup drives and subsystems have been introduced by MegaTape Corporation: the MT-1500 and the GT-88. Both are available in subsystems for use with DEC.

The GT-88 provides a formatted capacity of 1.2 GB and a sustained data transfer rate of 764 KB per second. It has a four-channel head that simultaneously writes four tracks of data to attain the transfer rate. Each channel is provided with 128 KB of cache buffer and the head is stepped nine times to generate 36 tracks on the 1/2-inch wide tape.

The 8mm GT-88 cartridge drive provides a capacity of 2.0 GB and writes data in the Exabyte format. The sustained data transfer rate is 246 KB per second.

The MT-1500 high-performance drive costs \$19,500 and the medium-performance version is \$16,500. The GT-88 is provided at \$7,950.

For more information, contact Clyde R. Cornwell, MegaTape Corp., 1041 Hamilton Rd., P.O. Box 317, Duarte, CA 91010-0317; (818) 357-9921.

Circle 425 on reader card

Chem-X/AMBER Interface Gets Green Light

Chemical Design's Chem-X molecular modeling system now offers a transparent interface to AMBER, the molecular dynamics simulation program. Version 3 of AMBER is also available.

A major advantage of Chem-X/AMBER is that data for structures built in Chem-X are converted automatically to the correct format before transfer to AMBER. This overcomes the problem of data input often encountered when AMBER is employed as a standalone program.

For more information, contact Hollon Bridges, Chemical Design Inc., 200 Route 17, Ste. 120, Mahwah, NJ 07430; (201) 529-3323.

Circle 423 on reader card

EIS Combines 20/20 With Ross Systems' Tools

Ross Systems has a new Executive Information System (EIS) for financial executives. Called MAPS/EIS, the system is a combination of software tools, allowing users to access, manipulate, report and graph data from Ross Systems' MAPS family of accounting software and from PC-based spreadsheets.

Ross Systems is offering EIS, the 20/20 spreadsheet from Access Technology, as part of MAPS/EIS. The spreadsheet integrates graphics, database management and project



The GT-88, from MegaTape Corporation, is a high-capacity drive using an 8mm cartridge.

modeling with powerful spreadsheet functionality.

MAPS/EIS also consists of CROSSVIEW, a cross-product inquiry and reporting tool that allows simultaneous access to Ross Systems' financial accounting applications; MAPS/MICROLINK, a link between Ross Systems' MAPS software, VAX and PC spreadsheets; MAPS/GL Management Report Writer, for extracting data from MAPS/GL at summary or detail levels; and the 20/20 Database Connection tool for accessing data from other databases directly from 20/20.

More information is available by contacting Sue Sweeney, Ross Systems, 1860 Embarcadero Rd., Palo Alto, CA 94303; (415) 856-1100.

Circle 424 on reader card

Attachment Support For VMS Mail

OA Technologies Inc. has announced OATmail for VMS. Version 1.0 will allow VMS users to send attachments to VMSmail messages. OATmail for VMS works as a standalone menu-driven interface for VT users or as a programmatic interface for OATmail PC users. The special programs of OATmail permit the inclusion of attachments of all format types (text and binary) for transfer through the VMS mail router and across the DECnet. If format conversion is required, attachments are routed automatically through format conversion utilities for conversion of incompatible WP, spreadsheet and database files.

OATmail for VMS is priced from \$2,500 for a MicroVAX II to \$7,500 for the VAX 8800.

To find out more information, contact Michael Jones, OA Technologies Inc., 1001 Craig Rd., St. Louis, MO 63146; (314) 432-3622.

Circle 426 on reader card

"Parts Bin" Saves Time And Money

LESTECH International has announced "Parts Bin". Written in COBOL, the routines are designed to be used in a commercial DP development environment using VAXs.

"Parts Bin" includes routines for text manipulation, security, conversion of dollar amounts to verbal descriptions, date manipulations, specialized formatting and a comprehensive menu system. Also provided with "Parts Bin" is a user's manual, the RUNOFF text file for the user's manual, test programs and examples and the source code for each routine.

A one-time, single CPU/Network license is available for \$99.

To learn more, contact LESTECH Intl., P.O. Box 5968, Auburn, CA 95603; (916) 823-2208.

Circle 427 on reader card

SL-GMS Offered For Less Than \$10,000

SL-GMS from Sherrill-Lubinski, can produce anything from basic screens with simple graphics management to fully articulated

visualizations of dynamic (animated) processes.

Five integral components make up the complete SL-GMS development system: SL-DRAW, a mouse-driven interactive graphics editor; the basic Graphical Modeling System Function Library (SL-GMF); the Graphical Modeling Language (SL-GML), a useful graphics interpreter; the Graphical Modeling Dynamics Library (SL-GMD); and (SL-OOE) a comprehensive Object-Oriented

How Much Faster Will Your Computer Be With MASTERDISK?



As Fast As It Can Get.

Add one of MasterDisk's disk storage systems to your DEC computer and discover what you can do with significantly increased speed and storage:

- Make a MicroVAX II outperform a VAX 8600*
- Double the number of users on the system and get a better performance for each user*
- Improve disk system throughput by as much as 450%*

MasterDisk is the most convenient and cost effective means available to attain the maximum throughput from your existing DEC system.

Storage Capacities - 152 megabytes to 2.93 gigabytes

Compatibility - All Q-Bus and Unibus systems including MicroVAX II, & 3000s; PDP-11s, and VAXs

Warranty - Exclusive TWO YEAR WARRANTY with Nationwide service and support

Mounting/Packaging - Rack mount, floor stand, table top or internal mounting

Delivery - Within 30 days, complete and ready for simple customer installation

* Actual field application data reported by some of our enthusiastic customers

MasterDisk®

Call Department D1 for information.

(617) 443-7711



American Digital Systems Inc.

75 Union Avenue, Sudbury, MA 01776-9990

CIRCLE 246 ON READER CARD



Become a 'C' Expert...

Order *Let's C Now*

by Rex Jaeschke

*A Self-Teaching Guide to C Language
in Two Volumes*

Volume 1: Introductory material
13 User-friendly chapters
A guide to learning C

Volume 2: Advanced instruction
13 self-teaching chapters
All you need to know to use C

26 lessons from *DEC PROFESSIONAL* magazine's "Let's C Now" column, updated and compiled by author Rex Jaeschke. Written for any operating system using DEC hardware, primarily for VAX and PDP.

Plus: Tested examples
Chapter summaries
Glossary
Author's hints and suggestions
Workbook format

For fast service call (215) 542-7008 with credit card information, or clip and send the attached order form.

Please complete and return with payment to:

PROFESSIONAL PRESS, INC., P.O. Box 503, Spring House, PA 19477-0503

Payment must be made in US dollars and drawn on a US bank.

Please send me:

_____ **two-volume set(s)** of *Let's C Now* at **\$42.95** plus \$3.00 (Canada \$6.00) for postage and handling per set.
_____ copy(ies) of *Let's C Now, Volume 1* at \$22.95 plus \$1.50 (Canada \$3.00) for postage and handling per copy.
_____ copy(ies) of *Let's C Now, Volume 2* at \$22.95 plus \$1.50 (Canada \$3.00) for postage and handling per copy.

Please charge my credit card: VISA MasterCard

Account # _____

Expiration Date _____ / _____

Signature _____ Date _____

Name/Title _____

Company _____

Address _____

City _____ State _____ Zip _____

Country _____ Telephone () _____

Environment that manages and controls the underlying architecture.

SL-GMS comes in two forms. The Development configuration starts at \$9,500 for screen composition, management and editing, and goes to \$12,500 with the addition of editing/management of coherent binding. The application or run-time configuration starts at \$2,400 to \$3,600 for the coherent binding version.

To learn more, contact Sherrill-Lubinski, Ste. 110, 240 Tamal Vista Blvd., Corte Madera, CA 94925; (415) 927-1724.

Circle 430 on reader card

RAXCO Unveils VAX-To-FAX

RAXCO Communications has introduced RAXMAIL, an easy-to-use, efficient and complete system for managing FAX, Telex and Teletex (European communication mode) messages in VAX/VMS environments. It lets companies centralize FAX control, while giving every VAX terminal user the ability to send a FAX from a VAX terminal.

RAXMAIL offers storage queues where users store multiple FAX messages. It waits until FAX lines are available, then sends stored messages at the first opportunity and alerts the user about message status.

More information is available by contacting RAXCO Communications, 2440 Research Blvd., Rockville, MD 20850; (301) 258-2620; FAX: (301) 330-5756.

Circle 431 on reader card

MessageNet V3.0 Integrates Networks

S&H Computer Systems Inc. announced V3.0 of MessageNet, data communications management software for VAX/VMS systems. MessageNet 3.0 integrates data communications across both public and private networks, including DECnet. It automates access to Western Union's EasyLink, ITT TIMETRAN Network and MCI Mail. The S&H package also features proprietary data compression and error-checking protocols.

The MessageNet Base software starts at \$1,500. A 90-day demonstration version is available for \$150 on TK-50, plus \$50 for each Gateway.

For further information, contact Richard Dohrmann, S&H Computer Systems Inc., 1027 17th St. S., Nashville, TN 37212; (615) 327-3670; Telex: 786577.

Circle 434 on reader card

ADSIM Enhancement Runs On VAX

Applied Dynamics International (ADI) has announced ADSIM/VX, an enhancement

that allows its users to run ADSIM, its proprietary simulation software, on any VAX. ADSIM/VX allows continuous system modeling language to run in a standalone environment for program development, testing and debugging.

Until now, ADSIM has been used in a real-time environment where a VAX control computer, after compiling the ADSIM source program, is used to load the object module into ADI's AD 100 digital parallel processor. The AD 100 then runs the actual simulation.

ADSIM/VX saves time and money by allowing multiple users to develop simultaneously and debug simulation programs off-line on a VAX processor.

ADSIM/VX is compatible with the entire VAX line running VMS, V4.5 or higher, including the MicroVAX series.

Find out more by contacting Larry Bobrowski, Applied Dynamics Intl., 3800 Stone School Rd., Ann Arbor, MI 48108; (313) 973-1300.

Circle 433 on reader card

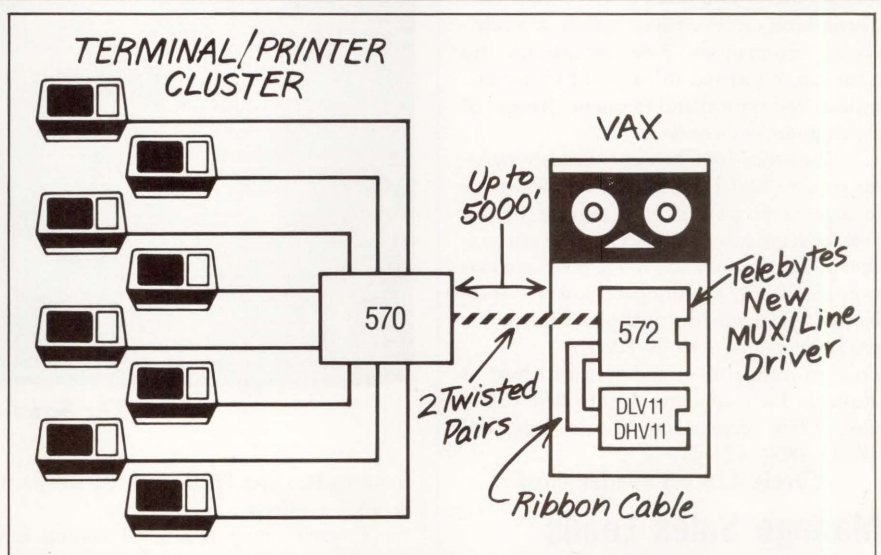

VAX/MICROVAX REMOTE TERMINAL CLUSTER WIRING IS A SNAP WITH TELEBYTE'S NEW QUICK MUX 572.

Everything about the new Quick Mux 572 multiplexing controller for the DEC multi-user environment is simple. Eliminated are the RS-232 connector panels on the backpanel of the CPU. Instead, there's one small bracket.

Instead of 8 separate hook-ups, cables, line drivers, etc., there's one 4-pin connector for a single, 2 twisted pair composite link cable over which the CPU communicates with 8 full duplex remote terminals, all operating simultaneously up to 19,200 baud. And the remotes can be located 5000 feet from the CPU.

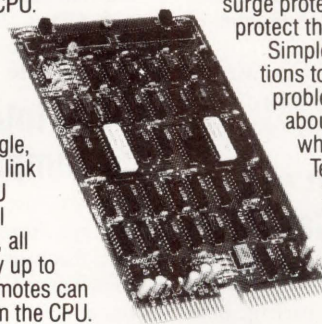

To make things even simpler, we've packaged the Quick Mux 572 on a dual DEC PC board to install "in a snap" inside the CPU. We've even built lightning and surge protection into each unit to protect the composite link.

Simple, elegant, low cost solutions to data communications problems—that's what we're all about. Call or write today to see what we've thought up for you.

Telebyte Technology, Inc.,
270 East Pulaski Road,
Greenlawn, NY 11740.

(516) 423-3232.

(516) 385-8080.

TWX: 510-226-0449.

FAX: (516) 385-8184.

**TALK TO
TELEBYTE
(800) 835-3298**

Controlled Power Introduces New UPS

Controlled Power Company's latest product, the Series 1000 Model D UPS meets the needs of small- to medium-scale VAX sites. It provides reliable, conditioned power and power distribution throughout the office, which decreases cost and time of installation.

The back panel of the Series 1000 Model D has output distribution panels that accommodate flush-mounted NEMA receptacles, distribution cables with receptacle and field-wired terminations. New receptacles and cable can be added in the field to accommodate the typical and frequent changes of a computer environment.

The Series 1000 Model D has zero transfer time to battery so there's never any interruption of power, ± 3 percent output voltage regulation, transverse noise attenuation of 120 db, common mode noise attenuation of 140 db to eliminate power disturbances. Available in single phase for power requirements of 1 to 20 KVA.

Further information and free brochure is available by contacting Controlled Power Co., 1955 Stephenson Hwy., Troy, MI 48083; (800) 521-4792.

Circle 428 on reader card

Manage Sales Leads With Marketrieve PLUS

Marketrieve PLUS is a sales lead tracking and market analysis software from IDSC Rental Company Inc. It provides telemarketing scripting, customer service and support and runs on VAX and HP 3000 systems.

Marketrieve provides quick access to data, search by company, contacts, phone number, parent company and follow-ups are tickled automatically. There are 50 user-definable fields. You can obtain market analysis reports, forecasts, sales management reports, advertising analysis and form and custom letters.

Customer service and support modules are available. Pricing is based on number of users and modules purchased.

More information is available by contacting IDSC Rental Company Inc., 350 Harvey Rd., Manchester, NH 03103; (603) 645-6677; FAX: (603) 645-6681.

Circle 436 on reader card

MCBA Releases Capacity Requirements Planning

MCBA Inc. released the final package in its Manufacturing System for VAX computers. Capacity Requirements Planning (CRP) is the 18th module in the MCBA system and completes the company's closed-loop Manu-

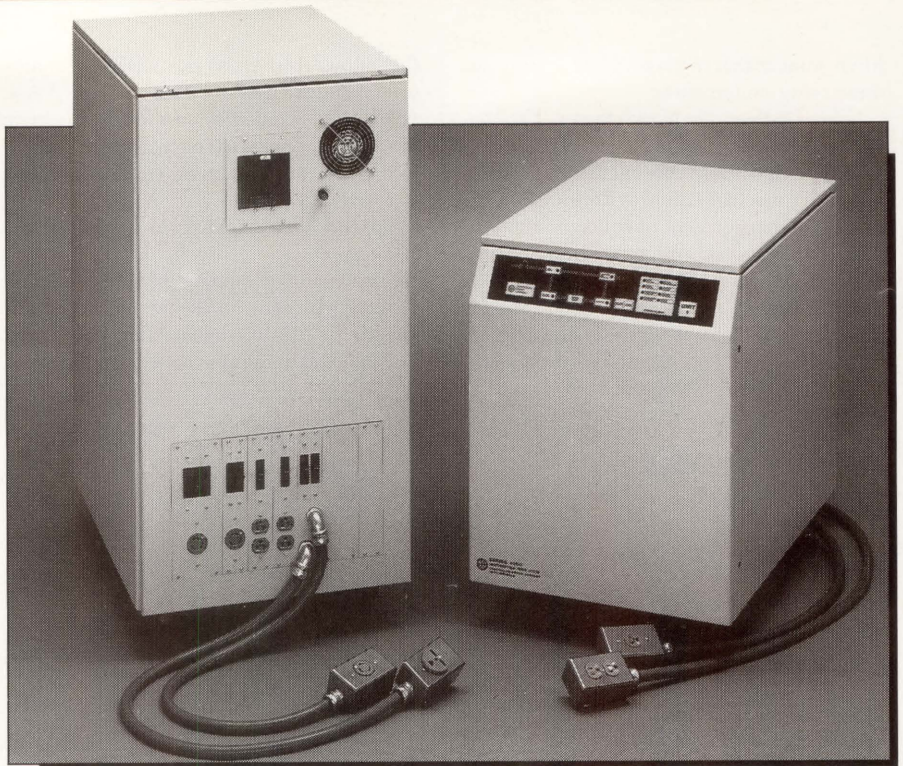

The Series 1000 Model D uninterruptible power system.

facturing Resource Planning (MRP II) system in VAX COBOL.

Capacity Requirements Planning is a shop floor management tool, allowing comparison of each work center's projected load to its available capacity. By having advance knowledge of potential bottlenecks, the manufacturer can make adjustments to the production plan.

Some CRP features include a "Simulated Load" file, which allows the user to alter orders to see the effects of alternate schedules without affecting the actual orders; and "Graphic Load Profile" graphically shows the load that exists on a particular work center for a given period of time, allowing the planner to quickly determine if capacity is adequate to handle the projected load.

For more information, contact MCBA Inc., 425 West Broadway, Glendale, CA 91204-1269; (818) 242-9600; Telex: 194188.

Circle 432 on reader card

GWA Introduces SYSPAC To Simplify Maintenance

SYSPAC is a menu-driven application package from GWA Information Systems Inc., that provides a cost-effective alternative to in-house VAX/VMS technical and operational personnel by simplifying VAX/VMS maintenance functions. It allows authorized users to add or update user accounts and parameters, and conduct orderly VAX system shutdowns and restarts.

SYSPAC also accommodates the setup of systemwide logicals, the sending of the systemwide login messages and the sending of terminal-specific messages.

SYSPAC builds a database of all files that have been stored on the backup volumes so users may inquire which backup tape volumes contain a specific file and can have the desired file restored. SYSPAC instructs the user to load the appropriate tape volume and executes all necessary commands to restore the file or files.

To learn more, contact George A. Merrill, Jr., GWA Information Systems Inc., 1432 Main St., Waltham, MA 02154; (617) 890-1838.

Circle 435 on reader card

VAXstation 8000 Performance Enhanced

Star Technologies Inc. has announced 50 and 100 MFLOPS vector accelerators for the new VAXstation 8000 workstation.

The Star ST-50 array processor, which operates at 50 MFLOPS, can be used as a single-user, real-time resource or as a shared computational resource serving up to three VAXstation 8000 workstations per array processor. The 100 MFLOPS ST-100 can service up to seven VAXstation 8000 workstations.

Get more information by contacting Gary Hertz, Star Technologies Inc., 515 Shaw Rd., Sterling, VA 22170; (703) 689-4400.

Circle 447 on reader card

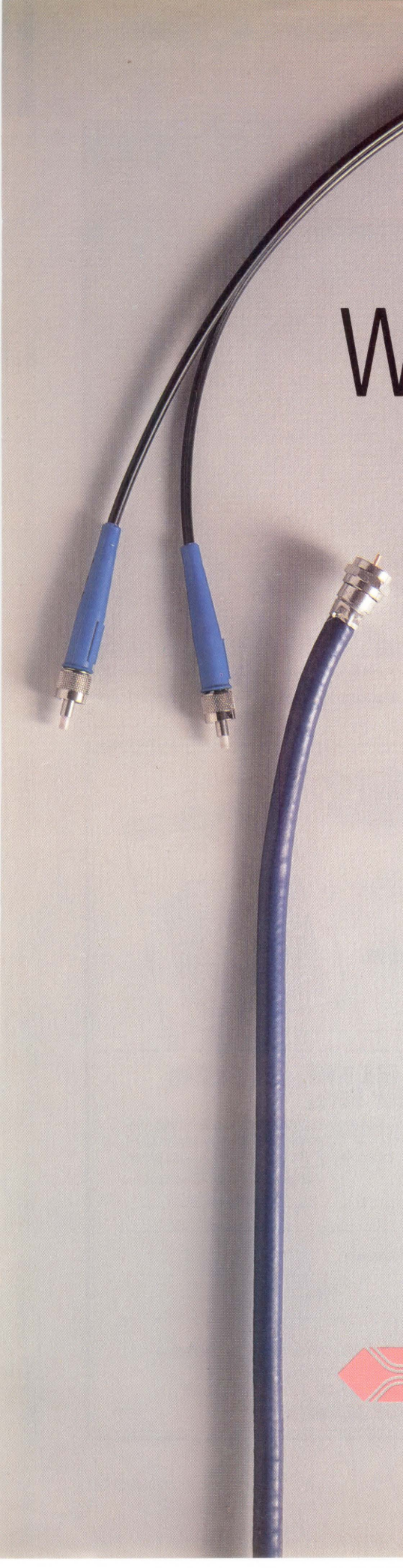

You choose broadband or fiber. We'll make it perform.

The security, noise immunity, long distance and easy expandability of fiber optics.

The interconnectivity, capacity, and full service capability of broadband.

The choice is yours. But either way, Chipcom's complete line of connectivity devices will make your Ethernet LAN perform. With full 10 Mbps throughput and 100% CSMA collision detection.

Until now, the real world high performance, reliability and superior diagnostics of Chipcom's Ethermodem™ family of connectivity products has been available only to broadband users.

Now we bring Chipcom's commitment to Ethernet excellence to the fiber optic user as well, with our new ORnet™ active star fiber optic system. ORnet is the only family of fiber optic couplers and transceivers that give you true 10 Mbps performance, standard redundancy features, long distance links and extensive diagnostic capabilities to let you spot faults at a glance. And like all Chipcom products, ORnet is fully IEEE compatible.

At Chipcom, we're fully committed to total Ethernet connectivity and performance.

No matter what medium it's running on.

CIRCLE 103 ON READER CARD



CHIPCOM

Quality products. For reliable networks.

195 Bear Hill Road Waltham, MA 02154
617-890-6844 Telex: 928338 Fax: 617-890-6857

Ethermodem and ORnet are trademarks of the Chipcom Corporation.

SunAccount Provides Multicurrency/Accounting

Systems Union Inc.'s SunAccount is designed to handle the multicurrency accounting and financial reporting needs of international organizations. SunAccount is a combined ledger accounting and reporting package that automatically translates and consolidates multicurrency accounts into a single-base currency.

SunAccount can import and export data from most WP database and spreadsheet packages. All financial statements and analysis reports can be read into spreadsheets for further manipulation. Exchange rate tables also can be downloaded from external systems.

SunAccount is available on most hardware systems including VAX. Licensing prices range from \$3,500 to \$100,000 depending on CPU size, operating system and number of users.

For more information, contact Stewart McKie, Systems Union Inc., 244 East 48th St., New York, NY 10017; (212) 753-7777; FAX: (212) 753-7825.

Circle 429 on reader card

```

MAINTAIN CHART OF ACCOUNTS

Account Code      <64003 >   Address Code      <MARINE/1 >
Account Name      <Marine Security Systems >
Lookup Code       <MARINE >
A/c Type (D/C/T/P/B) <D>         Direct Debit      < >
Bal.Fwd/Op.Item(B/D) <0>
Account Status    < >         Priority           <2>
Area              <US2 >       Pay Method (C/B/ ) < >
Account Type      <R >         Credit Limit      < 5000>
Sales Region      <1AS >
Analysis Category 4 < >         Payment Days     < 30>< >
Analysis Category 5 < >
Conversion Code   < >         Discount 1:      Days < 5> % < 3.000>
Suppress Revaluation < >       Discount 2:      Days < > % < >
Comment           < >
Permission        < >
Last Transaction   28/02/81       Transactions Present Y

-----
Selection <_ >   C=Create, A=Amend, D=Delete, E=Examine, M=Menu,
                  U=View, R=Report, T=Transfer, N=Menu
    
```

This screen shot from Systems Union Inc.'s SunAccount, multicurrency accounting software, depicts the creation of a new account in the ledger.

Learn more about VAX/VMS

Send for *Introduction to VAX/VMS, 2nd Edition* . . .

A self-teaching guide that explains and illustrates how to use VAX/VMS systems — from basics to systems and programming.

A handbook for beginners and a reference for experienced users.

Updated, revised and improved, the 2nd Edition's 10 Chapters and 8 Appendices give you overviews, explanations, and the "how to's" of . . .

- The VAX computer family
- DCL command language
- User accounts & environments
- Command procedures, mail, backup & help features
- DEC terminals
- Advanced features, Special function keys
- VAX/VMS file systems
- Defining symbols
- Lexical functions
- VMS device types & corresponding codes
- VMS error message facility
- Pictures, examples, programs & glossary

. . . and more.

**For Fast Service
Call (215) 542-7008
with credit card information.**

**Or complete
the order form below.**

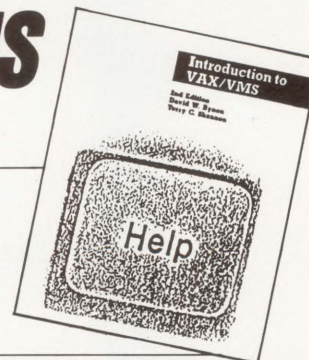

Introduction to VAX/VMS, 2nd Edition Order Form

Please send _____ copy(ies) of *Introduction to VAX/VMS* at \$29.95 each plus shipping/handling. (Shipping and handling for U.S. \$1.50, Canada \$3.00, All other foreign \$7.00). PLEASE MAKE PAYMENTS IN U.S. DOLLARS AND DRAWN ON A U.S. BANK.

Payment enclosed for \$ _____ Charge to: VISA MasterCard

Account No. _____ Expires _____

Signature _____ Date _____

Name _____ (PLEASE PRINT)

Address _____

City _____ State _____ Zip _____

Country _____ Telephone (_____) _____

Make checks payable and send order to:
PROFESSIONAL PRESS, INC., P.O. Box 503, Spring House, PA 19477-0503

Contact me with information on quantity discounts.

**ORDER NOW - \$29.95 - NEW REVISED & ENHANCED EDITION
SATISFACTION GUARANTEED.**

DP788

Clip and Send

The SAS[®] System

The Data Analysis Tool You Won't Outgrow.

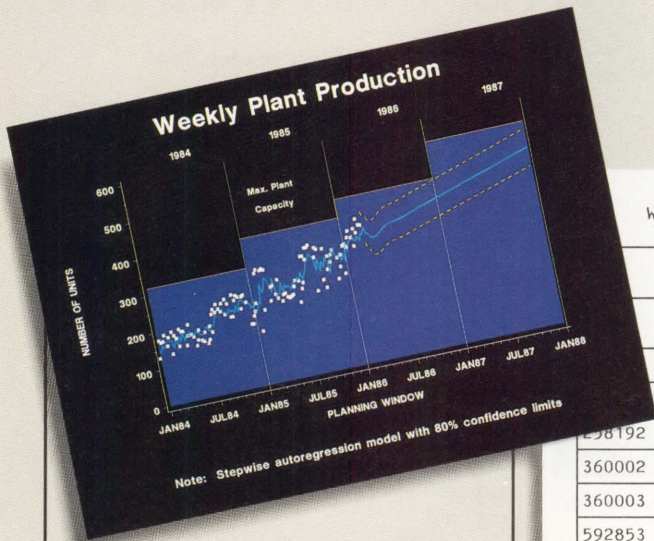

Warehouse Inventory Report - 16JAN87

	Quantity on Hand	Quantity on Order	Projected Reorder Date
	123980	10000	THU, FEB 12, 87
	89450	5000	FRI, FEB 20, 87
	20110	1000	MON, MAR 30, 87
	8585	0	TUE, FEB 10, 87
	15985	500	TUE, FEB 10, 87
	469120	20000	WED, FEB 18, 87

For details, send us your name and address. Or call a Software Sales Representative today.

The SAS System. It's the most widely installed tool for data analysis among VMS users*... And more.

If your job demands a powerful data analysis tool, the SAS[®] System is your solution. The SAS System gives you ready-to-use procedures for performing every kind of analysis—from simple descriptive statistics to advanced regression, analysis of variance, discriminant analysis, clustering, scoring, and more.

The SAS System reads data in any structure from any kind of file. You can create new variables, modify old ones, combine files, detect errors, and accumulate totals. Once your analysis is complete, you can report your results in lists, tables, charts, or plots.

And as your needs grow, the SAS System grows with you. All the tools you need for color graphics, forecasting, modeling, "what if" analysis, project management, optimization, and quality control are available in the SAS System. You choose the products you need, and enjoy the same easy-to-use language and syntax in each. Plus, you can use the same software on your personal computer.



SAS Institute Inc.
SAS Circle □ Box 8000
Cary, NC 27512-8000
(919) 467-8000
Fax (919) 469-3737

* Computer Intelligence, January 1986.

The SAS System runs on Digital Equipment Corp.'s VAX[™] series minicomputers and workstations under VMS[™] as well as other mainframes, minicomputers, and personal computers.

SAS is the registered trademark of SAS Institute Inc., Cary, NC, USA. Copyright © 1987 by SAS Institute Inc. Printed in the USA.

digital [™] Cooperative Marketing Program



Rate	Lots Tested	Rejected Lot Statistics		Mean	Percent
		Lowest	Highest		
30	4	1	4	2.5	0
40	6	1	6	3.5	33
50	6	3	8	5.5	66
60	6	4	9	6.5	83
70	7	4	10	7.0	85



Optifile optical disk subsystem from KOM Inc.

LorTec's 3 kVA UPS Ideal For Office

Providing clean, uninterrupted ac power for minicomputers like the IBM S/36, VAX and HP 1000, the new 3 kVA online UPS Model 302CAB, available from LorTec Power Systems Inc., incorporates reliable ferroresonant inverter in a compact, quiet, single-phase unit suitable for office use.

The LorTec 3 kVA ContinuAC UPS is equipped with a 100 percent solid-state output transfer switch. A touch-controlled meter function select panel lets you automatically scan, or manually monitor, nine conditions: dc voltage, battery current, bypass frequency, output voltage, output amps, output power, bypass voltage and inverter voltage. Where the UPS is installed in an unattended location, the remote performance-monitoring system can be installed in the computer room, at a security desk or instrumentation center.

For more information, contact Dale Lamirand, LorTec Power Systems Inc., 145 Keep Ct., Elyria, OH 44035; (800) 222-2600 ext. 265.

Circle 437 on reader card

Microbiology Software Module Enhanced

System Analysis Corporation has announced Micro-CAL, an enhanced microbiology software module designed for the micro-

biology laboratory. Micro-CAL provides comprehensive features and audit trails, including patient and specimen status, test ordering, culture workups and histories, daily and cumulative patient reports and epidemiology studies. The system is fully integrated with the Clini-CAL Laboratory Information System, which runs on DEC computers.

Some features include online or printed workcards, specimen plating requirements, user-defined specimen label format and quantities, online error checking and comprehensive Epidemiology reports.

Learn more by contacting Gail Rutherford, System Analysis Corp., One Hollis St., Wellesley, MA 02181; (617) 237-9500.

Circle 438 on reader card

NLI Announces DataTalker For Rdb

Natural Language Incorporated announced the availability of the NLI DataTalker and the NLI Connector for the VAX Rdb relational database management system. The NLI DataTalker is a natural language interface that lets you access relational databases using conversational English. The NLI Connector customizes the DataTalker for the particular database application.

The DataTalker can handle ad hoc, complex and unstructured queries because it understands the concepts, context and rules

of sentences. It supports SQL-based relational databases including ORACLE, Ingres, SYBASE and VAX Rdb.

The NLI DataTalker and NLI Connector are priced from \$4,500 to \$80,000 depending on CPU.

More information is available by contacting Allen Joesepp, National Language Inc., 1786 Fifth St., Berkeley, CA 94710; (415) 841-3500.

Circle 439 on reader card

KOM Supports RSX With OPTIFILE II

The OPTIFILE II software device driver from KOM Inc., now supports Toshiba 5 1/4-inch and Fujitsu 5 1/4-inch optical disk drives. PDP/RXS-11M and 11M-PLUS users can migrate current applications to optical technology. This provides an ideal combination: large storage capacity of 800 MB, but with the compactness of 5 1/4-inch storage.

OPTIFILE II, an essential component of an optical storage subsystem, allows optical drives to emulate standard magnetic devices without system or application changes required.

OPTIFILE II RSX currently supports SONY, OPTIMEM, OSI and ATG 12-inch drives. A VMS version of OPTIFILE is available, which means media interchangeability between the two operating systems is possible. Data written to a platter from an RSX host computer can be read by using VMS and vice versa.

For more information contact Linda M. Bradley, KOM Inc., 145 Spruce St., Ottawa, ON K1R 6P1; (613) 238-7766.

Circle 440 on reader card

MEC Bridge Provides DECmate-To-PC Transfer

Microsystems Engineering Corporation's new product MASS-11 Bridge, allows direct transfer and conversion of WPS documents residing on DECmates to PCs or vice versa.

Bridge also lets any two PCs running MASS-11 to transfer DOS or MASS-11 files, supplying direct, simultaneous communication.

To transfer a file from MASS-11 WP to the DECmate, MASS-11 Bridge first converts the file to the DX file format and then transfers it to WPS on a DECmate. From a DECmate to a PC, the document is first transferred and then converted.

MASS-11 Bridge is available for IBM PCs or compatibles for \$195 per PC.

Find out more by contacting Microsystems Engineering Corp., 2400 W. Hassell Rd., Ste. 400, Hoffman Estates, IL 60195; (312) 882-0111.

Circle 441 on reader card

The SAS[®] System

The Quality Control Tool You Won't Outgrow.

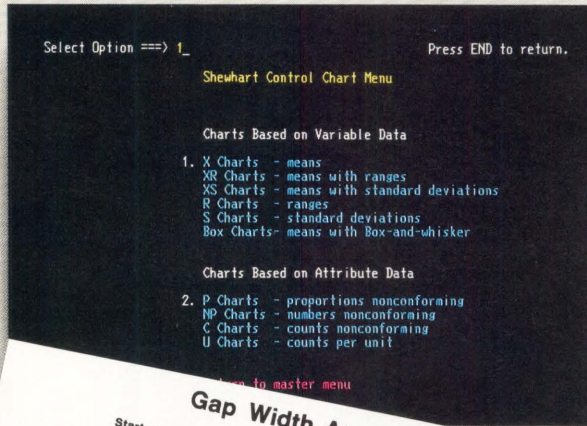

histograms, scatter plots, and more.

In fact, you'll find the SAS System a key decision support tool at every stage of production. Analyze manufacturing data using everything from simple descriptive statistics to advanced methods such as nonlinear regression. Produce reports for line workers, process engineers, and managers. Plan optimal production schedules. Manage inventories.

It's easy to combine tools in the SAS System to meet your changing information needs. We've even created a prototype menu system to get you started. Novice users can run complete applications with just a few key-strokes, and your programmers can tailor the sample applications.

See for yourself how the SAS System brings you higher productivity, lower production costs, and greater customer satisfaction. Just send us your name and address. Or call a Software Sales Representative today.

Better Quality Products Begin with the SAS System.



SAS Institute Inc.
SAS Circle □ Box 8000
Cary, NC 27512-8000
(919) 467-8000
Fax (919) 469-3737

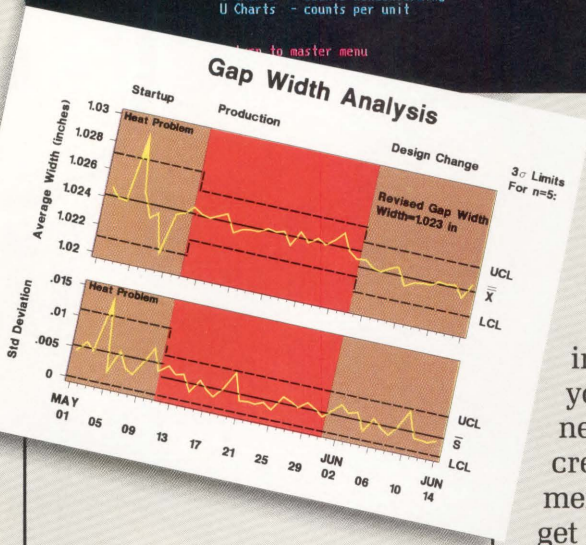

When quality counts, you can count on the SAS[®] System...software that keeps you in control.

The SAS System gives you a faster, easier way to put statistical quality control in action. And you don't have to be a programmer to use it! Easy-to-use procedures let you turn production data into powerful graphic presentations. You can generate all basic types of Shewhart control charts, as well as cumulative sum and moving average control charts,

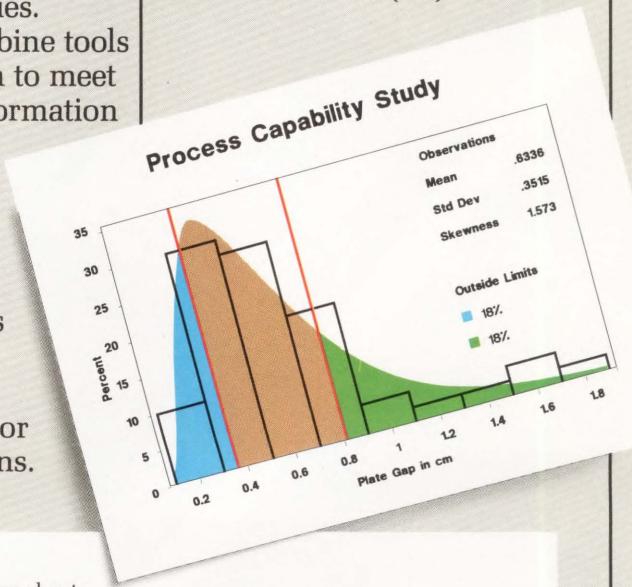

- Send me more about the quality control tools in the SAS[®] System.
- Include details about training.
- Tell me other ways the SAS System can work in my company.
- Call me to discuss a 30-day trial.

Please complete or attach your business card.

Name _____

Title _____

Organization _____

Address _____

City _____ State _____ ZIP _____

Phone () _____

Machine _____ Operating System _____

Mail to: SAS Institute Inc., Attn: CC
SAS Circle, Box 8000, Cary, NC 27512-8000

The SAS System runs on IBM 370/30xx/43xx and compatible machines, Digital Equipment Corporation's VAX[™] and MicroVAX II[™], Data General Corporation's ECLIPSE[®] MV series, Prime Computer, Inc.'s Prime 50 series, and the IBM PC XT and PC AT. Not all products are available for all operating systems. SAS is the registered trademark of SAS Institute Inc., Cary, NC, USA. Copyright © 1987 by SAS Institute Inc. Printed in the USA.

Software Solutions Adds IQL To 4GL Product Line

Software Solutions Company has announced an interactive query language utility (IQL) to its existing 4GL product line, which consists of a data entry utility, processing and report writer, financial report writer, menu/security system and query language. The entire range of products is integrated through a common data dictionary.

IQL lets the user select criteria, subtotal and total fields, perform calculation steps and output to screen, printer or disk file. Commands can be entered in prompting mode through a script file or through the pull-down menu environment.

IQL runs on VAX/VMS 4.0 or later. Prices range from \$2,000 to \$15,000. Learn more by contacting Charles Howard, Software Solutions Co., 2210 San Joaquin St., Fresno, CA 93721; (209) 486-4750.

Circle 444 on reader card

UNBOUND Introduces Helical-Scan Systems

UNBOUND Inc. has announced the availability of helical-scan tape technology in its full line of PDP-11, MicroVAX II and MicroVAX III QUBE desktop computers.

UNBOUND's helical-scan system options are based on Exabyte Corporation's EXB-8200 high-capacity magnetic tape drive that uses standard 8mm video cartridge tapes as media. Each cartridge stores up to 2.3 GB and costs less than \$10. A typical UNBOUND QUBE MicroVAX II system, fully integrated with a helical-scan tape, 760 MB disk, controllers, 5-MB memory and nine ports costs less than \$29,000 in small OEM quantities.

All UNBOUND helical-scan system and subsystem products use the standard DEC TMSCP driver for full compatibility. To find out more, contact Robert J. Rudy, UNBOUND Inc., 15235 Springdale St., Huntington Beach, CA 92649; (800) 862-6863, in CA (714) 895-6205.

Circle 442 on reader card

IQ Option Available For The VAX

CP International Inc. has announced that IQ, a natural language front-end and reference ranking option for its STATUS text retrieval system, is now available for the VAX.

STATUS/IQ replaces formatted commands with everyday English questions. STATUS/IQ is a text storage and retrieval system that prioritizes references and uses a natural language front-end.

STATUS/IQ is marketed and supported by CP International, the U.S.-based software

Master
the
power
of
UNIX®



Unisys video-based training programs unlock the mystery of UNIX in a quick, efficient way. Our UNIX System V and C language courses are flexible and adaptable to the schedule and needs of all levels of personnel.

There are eight courses in the series — from fundamentals to advanced aspects of UNIX and C language. Each cost-effective program lets you provide

training at your company site, whenever it's convenient.

For more information, call us toll-free at 1-800-222-0966 (in New Jersey, call 1-201-329-3899) and ask for department 7588, or use the coupon below.

Knowledge is power, and there's no easier way to master a subject than through the practical use of video.

Unisys Education Training Programs
a CUSTOMCARE™ Service

Send me information on the Unisys UNIX training program.

Name	Title	
Company	Business phone	
City	State	Zip

DEC788

Mail to:
Unisys Corporation
P.O. Box 2191
Princeton, NJ 08543

UNISYS

The power of ²

UNIX is a registered trademark of AT&T Information Systems.
CUSTOMCARE is a service mark and Unisys is a trademark of Unisys Corporation.

CIRCLE 295 ON READER CARD

REPRINTS

If you would like reprints of any *DEC PROFESSIONAL* articles or advertisements, contact the Production Department or your Regional Sales Manager at: *DEC PROFESSIONAL*, P.O. Box 503, Spring House, PA 19477, (215) 542-7008.

BUILD YOUR COMPUTER LIBRARY DEC PROFESSIONAL

**ORDER NOW!
Supplies Are Limited!**

Back Issue Sets Now Available!

DEC users read our magazine from cover to cover, use it and reuse it to help solve daily problems, improve their professional skills, and widen their perspectives.

Now you can build your computer library, receive issues you missed and replace well-worn copies.

Order the 43 available back issues of DEC PROFESSIONAL, July 1983 to present, as a set and save.

Order Now! Supplies are limited!



TO ORDER CALL (215) 542-7008 with your credit card information. Or complete and return the order form below. Payment must be included with your order.

▼ Clip and Send ▼

▼ Clip and Send ▼

BACK ISSUE ORDER FORM - DEC PROFESSIONAL

Please send _____ set(s) of 43 available back issues of DEC PROFESSIONAL. \$129 for each set ordered. Includes shipping by surface mail. Add \$10 for each set delivered to Canada.

PLEASE MAKE PAYMENT IN U.S. DOLLARS AND DRAWN ON A U.S. BANK.

Check enclosed for \$ _____

Charge to: VISA MASTERCARD

Account# _____ Ex. Date ____/____/____

Signature _____ Date _____

NAME _____ PLEASE PRINT

ADDRESS _____

CITY _____ STATE _____ ZIP _____

COUNTRY _____ TELEPHONE () _____

Mail completed form with payment to:

PROFESSIONAL PRESS INC., P.O. Box 504, Spring House, PA 19477-0504

DP788

division of the multinational Computer Power Group.

For more information, contact Norman Eagle, CP International Inc., 1 Water St., White Plains, NY 10601; (914) 686-9030.

Circle 443 on reader card

New DMMs Designed To Go Anywhere

The Instrumentation Products Division of Beckman Industrial Corporation has introduced multimeters. The models HD151, HD152 and HD153 are a new generation of heavy-duty digital multimeters (DMMs) and are hand sized.

The meters use a CMOS dual-metal gate A to D converter, which incorporates a fast voltage-to-frequency converter for range selection. By amplifying this signal and connecting it to a speaker, a tone proportional to the magnitude of the reading is produced. The HD153 detects the presence of most standard logic signals and alerts the user with a beep.

These models feature DC voltage ranges of 200mv, 2, 20, 200 and 1500 with resolution of 100uV. AC voltage ranges for the HD series are 200ms, 2, 20, 200 and 1000 with a resolution of 100uV.

The HD151 lists for \$149, the HD152 for \$169 and HD153 is priced at \$199. For further information, contact Rey Harju, Beckman Industrial Corp., 3883 Ruffin Rd., San Diego, CA 92123; (714) 671-4830.

Circle 463 on reader card

Softerm PC Preconfigured For DEC

Softerm PC from Softronics is a communications and terminal emulation program, available in versions preconfigured for VAX/VMS. These versions include a user-selectable keyboard remapping, which lets you use the same key commands used by the PC version of WordPerfect with the mainframe version; seamless remote virtual-disk, a concept pioneered by Softronics, provides seamless integration of file transfers between PC applications such as WPs, spreadsheets and database management programs, and the host system.

An optional tape is available with source and executable versions of the KERMIT and Softrans file transfer protocols. Each package comes with eight diskettes, binder and slipcase, technical reference manual and quick reference cards. Softerm PC revision 2.10 retails for \$195 and the optional tape is available for \$40.

For orders or information, contact Softronics Inc., 7899 Lexington Dr., Ste. 210, Colorado Springs, CO 80920; (800) 225-8590.

Circle 446 on reader card ■

SHIPPING NOW.

FREEDOM ONE ANSI.

**A HIGH QUALITY, ENTRY LEVEL ANSI TERMINAL OFFERING
OUTSTANDING PRICE/PERFORMANCE.**

Introducing the newest addition to the Freedom ONE family of terminals from Liberty Electronics. The Freedom ONE ANSI. The ONE terminal for your DEC and Data General requirements. This low-cost, ANSI-only terminal includes many of the same advanced features you'd expect to find in higher priced terminals.

For starters, it provides emulation of DEC VT220,[™] VT100[™] and VT52,[™] as well as Data General DASHER[™] D210 and D211. It has the same sleek, award-winning ergonomic styling of the original Freedom ONE. It comes with a high contrast amber 14-inch flat screen, with full tilt and swivel capability. It includes a choice of two detached, low-profile keyboard styles: DEC VT220 and Data General D210/211.

It's all backed by Liberty's comprehensive warranty programs and nationwide network of authorized service centers.

The new Freedom ONE ANSI. You won't find a higher quality ANSI terminal for the price. Anywhere.

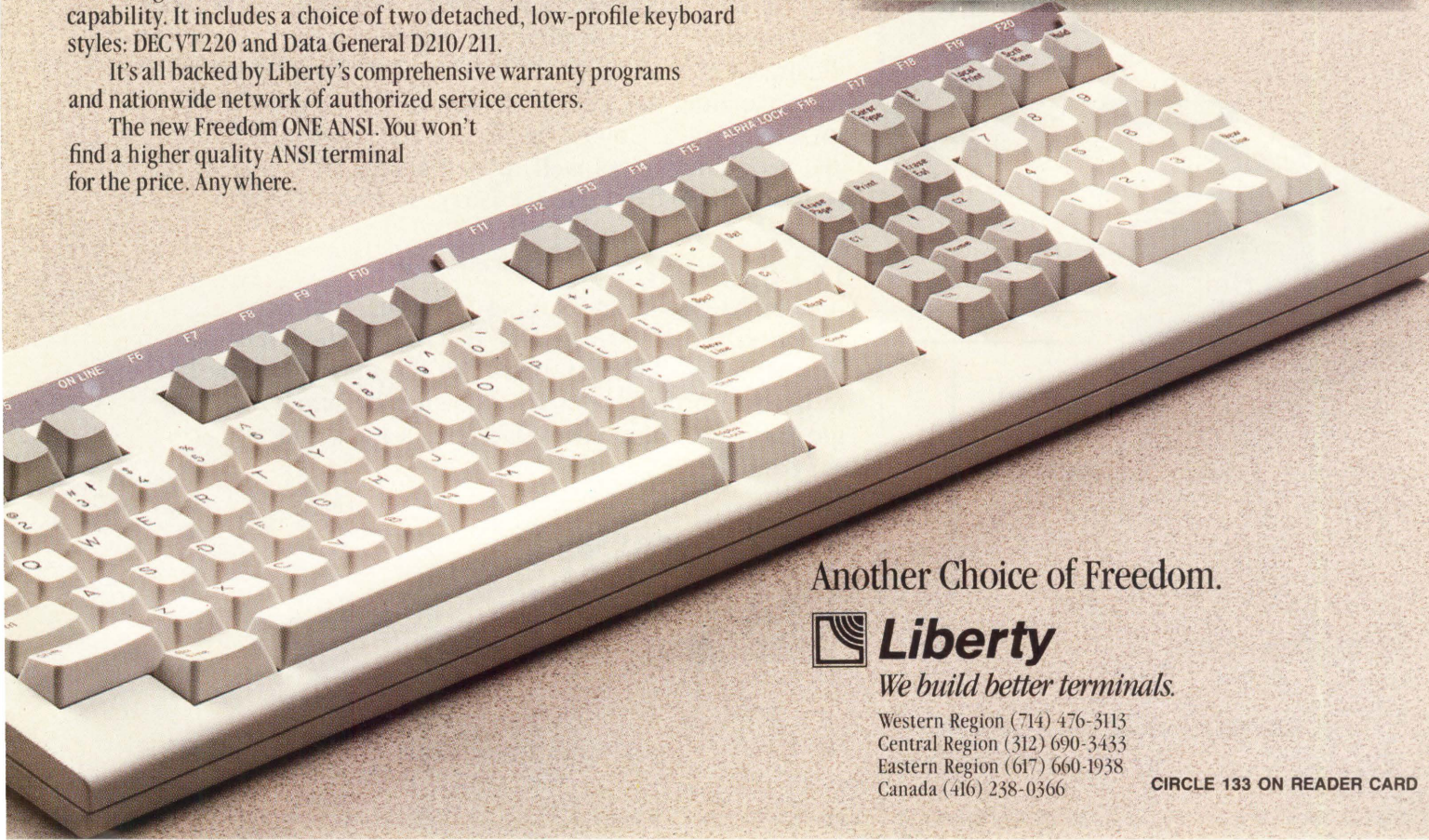

Another Choice of Freedom.



Liberty

We build better terminals.

Western Region (714) 476-3113
Central Region (312) 690-3433
Eastern Region (617) 660-1938
Canada (416) 238-0366

CIRCLE 133 ON READER CARD

professional press publications

Professional Press launched the DEC-specific publishing industry in 1979 with the publication of its first DEC magazine RSTS PROFESSIONAL.

Today Professional Press offers two DEC-oriented publications and a third, geared to the Hewlett-Packard marketplace. Plus two important texts for computing pros who want to learn about C language and VAX/VMS.

DEC PROFESSIONAL

The largest circulation DEC publication in existence with over 94,000 subscribers*— 100% buyer qualified* and dedicated to improving staff and equipment performance at DEC installations.

VAX PROFESSIONAL—The Software Journal for VMS

This bimonthly publication is the only technical journal dedicated solely to the users of VAX/VMS. It's the source of practical advice on how to write better software and make better use of the hardware on every VAX system — from the MicroVAX to the 8800.

HP PROFESSIONAL

A monthly magazine written for professional users and managers of Hewlett-Packard's business/commercial and technical computer systems. With 30,000* buyer qualified-subscribers, it offers by far the largest and most clearly targeted circulation in its marketplace.

INTRODUCTION TO VAX/VMS, SECOND EDITION

This revised and expanded self-teaching text explains and illustrates how to use VAX/VMS systems. Easy to learn for the computing novice . . . an excellent reference for VAX/VMS pros. Covers the basics and teaches systems and programming as well, plus glossary and appendices. Authors: David Bynon and Terry Shannon.

LET'S C NOW

A complete guide to learning C language in two volumes. Over 300 pages in 26 chapters in a self-instructing workbook format. All the information needed to become proficient in C. Plus chapter summaries, glossary, and author Rex Jaeschke's hints and suggestions.

PROFESSIONAL
press

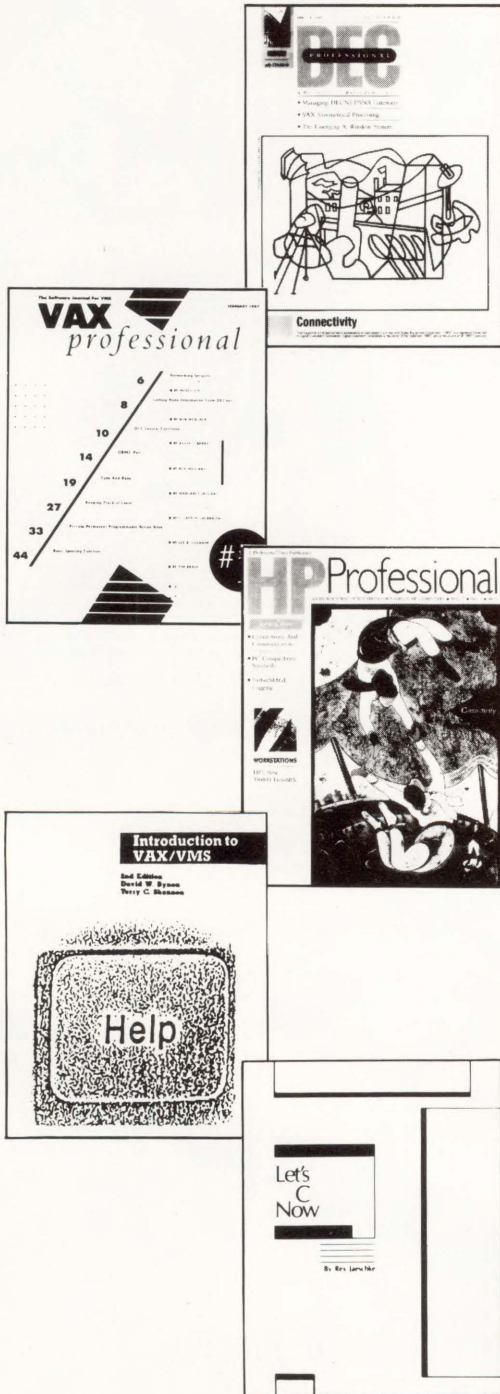

*December 1987 BPA Publisher's Statement, November issued analyzed.

For More Information Call (215) 542-7008

DP88-7

Imagine Buying New Equipment at Used Prices!

NEW
RA81-AA, AD
~~\$10,995~~
\$10,500

NEW
DELUA-M
\$3,195

NEW
DELNI-AA
\$1,150

NEW
RA82-AA, AD
\$13,195



NEW
DHQ11-M
\$1,295

NEW
HSC5X-BA, CA
~~\$9,650~~
\$9,450

KIMBERLY ELECTRONICS
800-843-4009
In NJ 201-387-0872
140 Route 17 North
Suite 210
Paramus, NJ 07652

NEW
LA75-CA
\$650



NEW
KDJ11-AB
\$1,650

NEW
National
MVII 8mb Memory
\$1,700

NEW
MS 630-CA
\$2,495

NEW
Fujitsu Disks
&
Subsystems
\$ CALL

NEW
Cipher Tapes
&
Subsystems
\$ CALL

NEW
Emulex
Disk, TAPE, & Comm.
\$ CALL

Full Mfg. Warranty Customer Service Compatibility Immediate Delivery
Call us for our latest prices on Digital, Fujitsu, Emulex, National Semi and ask for our new catalog.

Call Kimberly where what you imagine can become a reality!



COMPUTERS AND PERIPHERALS
IN STOCK PROMPT DELIVERY

NEW BUY DEC™ USED SELL

SYSTEMS
MODULES
PERIPHERALS
VAX⊕Q-BUS⊕UNIBUS

CALL TODAY

617-547-4005 • 800-892-9230

TELEX 374-8460 FAX (617) 354-1417

COMPETITIVE PRICING  DEC DEALERS ASSOCIATION

LET US QUOTE YOU ON ALL YOUR DEC NEEDS

*DEC A TRADEMARK OF DIGITAL EQUIPMENT CORP

ELI HEFFRON & Sons inc.
139 HAMPSHIRE ST. CAMBRIDGE, MA. 02139

DEC PRO Garage Sale!

- EQUINOX DS5 . . . loaded
- ABLE DH/DM 16 DHV ports for your VAX with full modem control and distribution panel
- DILOG 16 port VAX DHV same as above
- ABLE DH/DM for PDP UNIBUS with distribution panels
- SI 6100 UNIBUS controllers
- UNIBUS memory: 11/44 style 1 MB boards
- UNIBUS 4- and 8- slot backplanes
- ABLE Enable + cache
- DLV-11, 4 MB memory, disk controller (DR), and other

call KEVIN at

215-542-7008

"Hi! I'm Maggie Connelly, a purchasing manager at Midwest Systems. Please accept my 'invitation' to call us about purchasing your used or new DEC Equipment.

*I think you'll be glad you called us, and for two very good reasons. The **first**, is that*

***we are active buyers... not shoppers.** We buy well over 5,000 DEC products **every month** and are rated as the nation's largest purchaser of DEC equipment. The **second** reason is simple. We buy both **individual** DEC products and **complete** systems ... and make immediate cash payment.*

During the nine years that I've been at Midwest, we've helped thousands of people and companies who were faced with the task of selling their unneeded DEC equipment. I'm sure that you'll also enjoy working with us and our 16 very courteous and helpful buyers."



**"We'll
pay you
CASH for
your unneeded
DEC* equipment"**

Please accept our invitation... **Call us today** on our toll-free number: **1-800-328-7000, ext. 9937.**
(In Minnesota, call 1-612-894-4020).

We look forward to talking with you.

Thanks!

Maggie Connelly

**MIDWEST
SYSTEMS**
INCORPORATED

2800 Southcross Drive West, Burnsville, MN 55337

* DEC is a registered trademark of Digital Equipment Corporation.

digital

digital

PUBLIC NOTICE!!

BOSTON BOARDS & SYSTEMS, INC.

55 Rear Main Street, Kingston, MA 02364



Boston Boards
&
Systems



Boston Boards
&
Systems

617-585-7777

Our Guarantee Is Our Reputation!!

<p>SPECIAL VEGETARIAN PLATTER W/BEVERAGE \$3.75</p>	<p>8000 SERIES Systems & Peripherals</p>
<p>MICROVAX II Systems & Peripherals</p>	

\$1 MILLION + *DEC inventory
15% to 60% OFF DIGITAL LIST!!
CABLES TO CPU's!! CALL TODAY!!

WE ALSO BUY NEW & USED EXCESS *DEC INVENTORY

EMC²

cipher

GD
CONTROL DATA

EX
EMULEX T.M.

KENNEDY

FUJITSU

T.M.
National Semiconductor

digital

FAX: 617-747-6255
TELEX #920038BBS

Digital is a registered trademark of Digital Equipment Corporation

digital

CLASSIFIED

EQUINOX DS-5

Cabinet (Rackmount)
Processor Set
1 24-RS
3 24-CS

List > \$12,500

Best Offer
Over \$8,500

Call Kevin
215-542-7008

REMTEC FUJITSU 2284. 168Mb, Disc Drive, \$695. Fully guaranteed. (415) 463-3511.

REMTEC FUJITSU 2294K. 336MB, \$2,495. (415) 463-3511.

- PRO 350/380 MEMORY BOARDS
 - DISK DRIVES - BIG & FAST FOR PRO
 - RAM-DISK Software for Micro/RXS, 11M (+) & P/OS*
- Call 415-420-9579
Proto Systems
1238 Josephine St, Berkeley, CA 94703

C LANGUAGE CONSULTING AND EDUCATION by noted **DEC PROFESSIONAL** columnist. Also other languages and packages on RSX, VMS, RSTS and MS-DOS, including DBMS and DECnet. Applications experience includes real-time, process control, engineering, scientific and commercial systems. Rex Jaeschke. (703) 860-0091.

WANTED

BARE-BONES 8200/8250
(No Unibus)
With or Without DEBNA & KDB50
Call Kevin Kennelly at
215-542-7008

SMART TRADER

FOR COMPUTER & EQUIPMENT DEALERS/BROKERS

"GET RID OF THE OLD NOTE BOOK AND BE A SMART TRADER"

- ★ Automate your Buy-Sell inquiries ★
- Runs on any IBM-XT/AT or Compatibles
- Menu Driven
- Record Want-To-Buy & Want-To-Sell Inquiries
- Instant Matching of Buyers & Sellers
- On-Line Query & Report by Model No., Company Name & Date
- Reports on Products-For-Sale & Products-In-Demand
- Mailing List/Label
- Rolodex Features
- Automatic Phone Dialing (optional - hardware dependent)
- Update Company & Product Data

\$450

DEMO DISK & DOCUMENTATION - \$50.00

dce DIGITAL
COMPUTER
EXCHANGE INC
2773 Industrial Blvd., Hayward, CA. 94545
Call (415) 887-3100
FAX (415) 887-5590

INFORMATION

Rates: 1 time: \$600
 3 times: \$550
 6 times: \$500
 12 times: \$450

Size: 1/9 page — 2³/₁₆" x 2³/₄"

Camera ready mechanical required.

Typesetting and composition available.

For more information call Mary Browarek at (215) 542-7008.

VAX TIME

- 785, 780 Computers
- Rates from \$6.00/Hour
- Timeshared or Dedicated
- Tymnet access available
- Disaster Recovery Services



AMERICAN DIGITAL TECHNOLOGIES
 Costa Mesa, California

CONTACT:
 (800) 669-7070
 (714) 957-8440

CIRCLE 200 ON READER CARD

SWITCH COVERS

Protective Covers for Digital Equipment

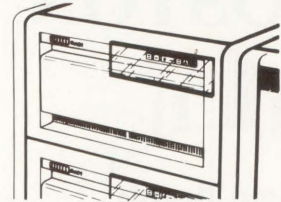

RA81	\$13	VAX 11/750	\$15
RA60	\$13	VAX 11/780	\$15
MICROVAX	\$13	PDP 11/23	\$13
SA482	\$13	PDP 11/73	\$13



1-800-445-8296

3657 Hi Dale • Lake Orion, MI 48035
 313-332-7997

CIRCLE 205 ON READER CARD



MEADOWLARK ENTERPRISES
 37 High Street
 Danvers, MA 01923

We need to buy your excess DEC equipment now!

VAX & PDP-11

Turn your unwanted computer equipment into cash!

- ✓ Large inventory
- ✓ Immediate availability
- ✓ Super Prices

617-777-4666 idd
 FAX-617-777-8433 800-DEC-DLER

CIRCLE 204 ON READER CARD

VAX® RENTALS

MICROVAX II
 VAX 700 SERIES
 VAX 8000 SERIES
 Systems & Peripherals

- Add-On Flexibility
- Purchase Options

3 Months • 6 Months • 12 Months

BROOKVALE ASSOCIATES

ddc Digital Dealers Assoc.

EAST COAST
 (516) 273-7777

WEST COAST
 (206) 392-9878

CIRCLE 202 ON READER CARD

DISK PACKS FOR DEC™



Go with the leader in Nashua hard disk storage media sales.

•New! •Error Free! •Preformatted!

For DEC RM05	256 MB Disk Packs	\$ 495.
For DEC RM03	67 MB Disk Packs	\$ 245.
For DEC RP06	176 MB Disk Packs	\$ 425.

Call Toll Free:

1-800-445-4832



COMPUTER DISTRIBUTING COMPANY, INC.

39 East Freeport Blvd. • Sparks, NV 89431

CIRCLE 209 ON READER CARD

VAX CAREERS SOUTHEAST

Being in the right place at the right time is the best way to take advantage of a career opportunity! Making you aware of the right place and presenting your credentials at the right time is what I do best!

Numerous opportunities for all levels of VAX professionals. Skills in the following areas are highly valued:

- | | |
|--------------|-------------------|
| • FORTRAN | • ADABAS |
| • COBOL | • MANUFACTURING |
| • DATATRIEVE | • HABITAT/SCADA |
| • ORACLE | • DECNET/ETHERNET |
| • DBMS-11 | • ALL-IN-ONE |
| • RDB | • MASS 11 |

CALL or WRITE

BRENDA CAREY, C.P.C.
 DIGITAL SPECIALIST

When you want to be in the right place at the right time!

(919-222-0231)

AMOS & ASSOCIATES

633B Chapel Hill Road Burlington, N.C. 27215

CIRCLE 201 ON READER CARD

Look for the logo ...

The DIGITAL DEALERS ASSOCIATION was formed in 1982 as a trade association to promote ethical dealings in the used DEC* marketplace.



Buy or sell with confidence from a dda dealer!



For membership & other information:
313/475-8333
 107 S. Main Street
 Suite 202
 Chelsea, MI 48118

*DEC is a registered trademark of Digital Equipment Corporation.

CIRCLE 203 ON READER CARD

This publication is available in microform from University Microfilms International.

Please send information about these titles:

Name _____

Company/Institution _____

Address _____

City _____

State _____ Zip _____

Phone (____) _____

Call toll-free 800-521-3044. Or mail inquiry to: University Microfilms International, 300 North Zeeb Road, Ann Arbor, MI 48106.



East of the sun. West of the moon. Windjammer.



A place to live your fantasies.
A place to free your soul.

To cozy up to the Caribbean sun.
To dance among a thousand stars
to the rhythms of steel drums.
To play on sparkling white and
pink sand beaches.
To discover the underwater
paradise of the reefs.
To find a new friend and share the
intimacies of a sensuous night.

To come alive and live.
To remember for a lifetime.

6 days and 6 nights. From **\$625.**

Reservations toll free
1-800-327-2600
In Florida 1-800-432-3364

**Windjammer
Barefoot Cruises**

Post Office Box 120.
Miami Beach, Florida 33119.



CIRCLE 168 ON READER CARD

Cap'n Mike, rush me my free, full color 'Great Adventure' booklet and show
me the way to Paradise for 6 days and 6 nights from \$625.
Windjammer 'Barefoot' Cruises.
P.O. Box 120, Dept. 4288 Miami Beach, Fla. 33119.

Name _____
Address _____
City _____
State/Zip _____

ADVERTISERS INDEX

Reader Service Number	Page	Reader Service Number	Page
246	American Digital Systems.....155	138	MDBS, Inc.....85
267	Applied Digital Data Systems...133	139	MegaTape Corp.....35
238	Applix.....67	139	MegaTape Corp.....36-37
293	Arrow Electronics.....21	140	MICOM/Interlan Systems.....59
215	Arium Corp.....61	302	Micro Technology, Inc.....11
	AT&T Training.....97	142	NBS Southern.....19
301	B.J. Johnson & Assoc.....91	303	National Information Systems..129
180	BLAST/Communications Research Group.....96	235	Networx Data Products.....31
290	Boston Business Computing.....57	300	Nissei-Sangyo America.....71
227	Business Computer Services.....84	188	Nissho Electronics.....6
195	Cardinal Data Corp.....116		Norm DeNardi Enterprises.....151
279	Century Data.....62-63	305	Northwest Digital Systems.....78
103	Chipcom Corp.....159	288	Oregon Software.....152
104	Chrislin Industries, Inc.....65	244	Pacer Software.....145
107	Coefficient Systems Corp.....94	145	Park Software.....70
294	Coefficient Systems Corp.....95	242	PCS, Inc.....138
108	Cognos Corporation.....1	175	Persoft, Inc.....5
111	CompuServe/Data Technologies..101	240	Polytron Corp.....126
112	CompuServe/Data Technologies..103	148	Precision Visuals.....27
113	CompuServe/Data Technologies..105	153	Process Software.....70
286	CompuServe/Data Technologies..107		Professional Press.....156,160,168
241	CompuShare.....149	154	Progress Software.....93
179	Computer Methods Corp.....142	260	Qualstar Corp.....107
268	Computer Museum.....164	297	Rapitech Systems, Inc.....55
289	Cullinet Software Inc.....8-9	249	Raxco.....87
222	CVD Systems.....101	155	Relational Technology.....23
114	Datability Software Systems, Inc.....B.Cover	156	Restor Communications.....113
189	Datamedia Corp.....47	212	Richard Hirschmann of America, Inc.....100
234	Datasouth Computer Corp.I.B.Cover Dec Professional.....166		SAS Institute.....161
115	DEMAC Software Ltd.....90		SAS Institute.....163
184	Digi-Data Corp.....104	224	Scherers Communications.....81
299	Digital Business Systems.....112	271	Sherrill-Lubinski.....51
192	DILOG.....148	263	Sigma Information Systems.....127
272	Dow Jones Service.....121	275	Signal Technology.....I.F.Cover
121	EMC Corporation.....15	269	Software Techniques.....139
264	Emulex Corp.....7	158	Sorbus.....123
122	Equinox Systems, Inc.....2	159	SPSS.....131
256	Esprit Systems.....25	248	Stone Mountain Computing.....103
	Executive Software.....supplement	160	Summus Computer Systems.....137
273	Gejac, Inc.....33	161	Synctronics.....115
124	Grafpoint.....150	243	System Industries.....12-13
265	Graph-On Corporation.....29	291	Systems Strategies.....46
278	GrayMatter Software.....105	232	Systonetics.....20
126	Information Builders.....75	162	Talaris Systems.....79
190	Interactive Technology.....125	214	Telebyte Technology.....157
130	James McGlinchey.....152	252	Trimm Industries.....109
131	Jyacc.....45	165	TRW Customer Service Division.....49
132	Kea Systems Ltd.....20	285	Uniforum.....150
266	Kinetics.....143	225	Unisolutions Associates.....50
133	Liberty Electronics.....167	295	Unisys Education.....165
134	Logicraft, Inc.....175	187	Upper Bound Micro Computers, Inc.....153
135	Maintech, A Division of Volt Delta Resources.....43		VAX Professional.....119
304	MDB Systems.....17	167	Walker Richer & Quinn, Inc.....117
137	MDBS, Inc.....83	168	Windjammer Barefoot Cruises..173
		292	World Wide Data.....89
		171	Xyplex, Inc.....77

ADVERTISING

VICE PRESIDENT Helen Marbach
ASSOCIATE PUBLISHER Jeffrey Berman
ADVERTISING SERVICES

MANAGER Connie Mahon
SENIOR ACCOUNT EXECUTIVE

Dan Mainieri Jr.

CLASSIFIED ADS & USED EQUIPMENT
Mary Browarek

LIST RENTAL SALES Cathy Dodies

REGIONAL SALES MANAGERS

MID-ATLANTIC Mark Durrick

INTERNATIONAL Helen B. Marbach

MIDWEST, SOUTHEAST Peter Senft

**921 Bethlehem Pike
Spring House, PA 19477
(215) 542-7008**

REGIONAL SALES OFFICES

NEW ENGLAND

Trish McCauley
Senior Account Executive
Professional Press, Inc.
238 Bedford St., Suite 3
Lexington, MA 02173
(617) 861-1994

NORTHERN CALIFORNIA and NORTHWEST

A. G. Germano
Regional Sales Manager
Alonna Doucette
Account Executive
Professional Press, Inc.
903 Sneath Lane, Suite 220
San Bruno, CA 94066
(415) 873-3368 — 3369

SOUTHERN CALIFORNIA and SOUTHWEST

David Beardslee
Regional Sales Manager
Karin Altonaga
Senior Account Executive
Professional Press, Inc.
1010 East Union Street
Suite 101
Pasadena, CA 91106
(818) 577-5970

DEC
PROFESSIONAL



LOGICRAFT'S

Award

Winning Team

Logicraft, the leader in MS-DOS to DEC integration, delivers PC applications to VAX users with unique and cost effective connectivity products.

386Ware, the 1988 DR Target award winner for best hardware communications product, is an 80386 based DOS server that brings PC software to VAX terminals at speeds five times faster than an AT.

Cardware, the first product to provide true IBM PC emulation to the DEC

family of minicomputers, is still the best solution for Q-Bus and Unibus based systems.

Dataware makes your expensive VAX peripherals (printers, hard disks, etc.) available to PC users. MS-DOS data files can be stored on the VAX hard disk ensuring data back up and security.

Logicraft is committed to providing the best customer service in the industry. In the last year, we've tripled our service

organization to provide quick answers to your questions...if you have any.

Call us today for more information or a free demonstration of our award winning team of PC emulation products.

LOGICRAFT

22 Cotton Road, Nashua, NH 03063
(603) 880-0300 Fax 603-880-7229
CIRCLE 134 ON READER CARD

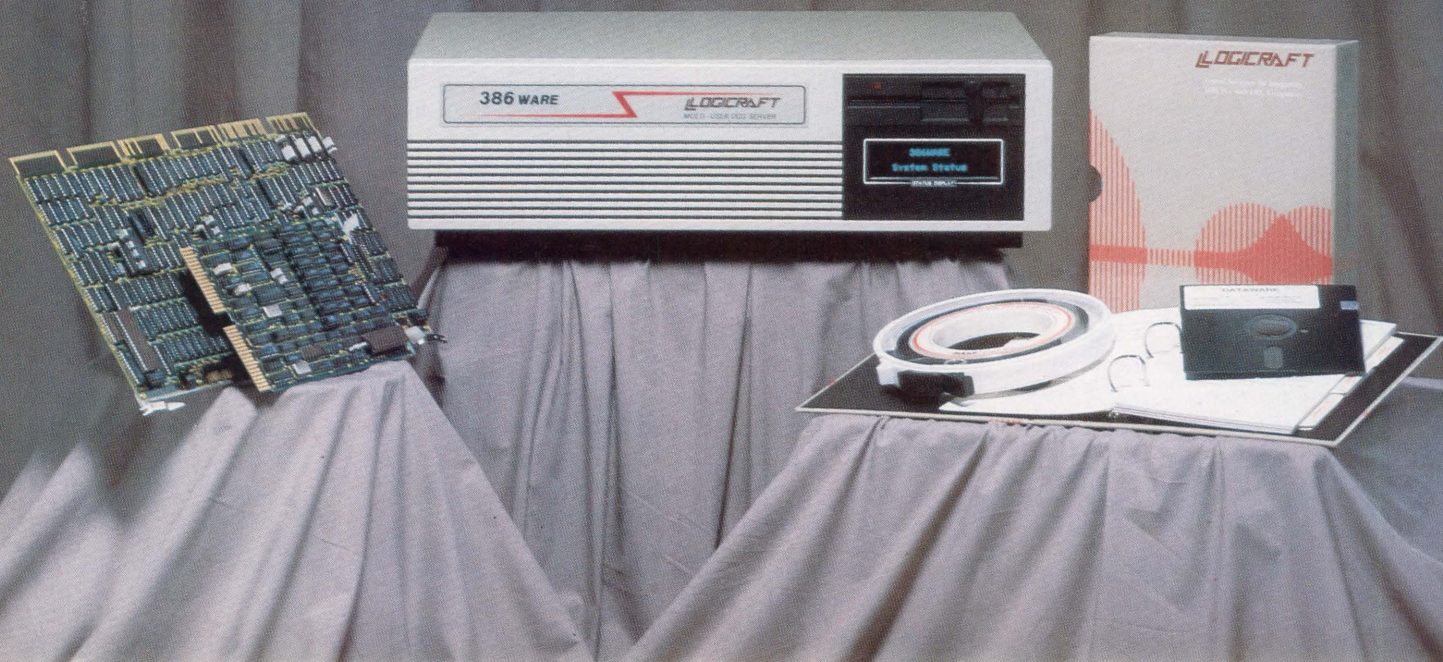

A Tale Of Two Idea Men

Programmers are notorious for never finishing a project. The culprit is creeping featurism. The bigger the project, the more likely you are to see creeping featurism. Whole sections of once acceptable code soon are perceived as garbage by the programmer. Time slips away as needed changes are made. Mania begins to set in.

This happens suddenly when it dawns on the programmer that the project is near completion and the baby is near birth. It won't take long to implement any changes, says the programmer to the project leader. He convinces the bosses that these additions are necessary. At this point, the world's greatest salesman should study the sales techniques employed by the most introverted programmer. A red cape and tights appear on the once meek programmer who suddenly feels duty bound to promote his needed features. His arguments go from, "The program will be no good without them" to, "This is what they really want." That's the first round of arguments. Soon, it turns into, "I've found out that this is what the competition is doing for its next release of a similar product. They'll kill us in the marketplace if we don't have it too."

It degenerates into, "I'll quit and kill the project if we don't have these features." During this period, the programmer has been promoting his new ideas, so the project leader lets him add a few features. When the programmer begins to code again, a smart project manager will threaten to release the product, bugs and all, swearing to publicly name and blame the programmer for any problems. The guy shapes up fast and gets a reasonable product out

the door, nine months late. That's on time in software parlance.

I admire the great programmers of the world. The better they are, the more unlikely they are to finish any project they've started. This is their nature and part of the programming process. I feel sorry for publishing houses that think programmers actually can do what they say. Sillier are the people who genuinely believe that a program will operate the way it's supposed to.

I tell you this about programmers, because they're the model for the biggest procrastinators in the industry; i.e., the corporate Fellow. These are guys who seldom write a line of code; they're still trying to finish their ideas.

In the world of small computers, there are a couple of characters worth mentioning. The first guy is Ted Nelson, who coined the term hypertext and has been one of the computer industry's grand pooh-bahs for decades. Nelson was the dinner speaker in 1977 at the West Coast Computer Faire, and he derided IBM, much to the delight of the audience, who perceived IBM as an ugly monster; the enemy of the personal computer movement.

Nelson has been refining his ideas for so-called project Xanadu, some hypertext be-all and end-all program.

I remember him when he worked on some sort of grand scheme at Processor Technology, a microfirm that rode high for a time. However, when the company failed, the idea lived on. So, he went on his own. A decade passed. Suddenly, Nelson is scooped up by Autodesk and named a Fellow there. He found his niche.

Another luminary is Alan Kay, an Apple Fellow. The classic computer-industry Fellows are the IBM Fellows. These are the big thinkers whom Kay and, to a lesser extent, Nelson emulated. The results probably will be similar. As

far as anyone can tell, an IBM Fellow's sole job is to cogitate and roam the hallowed halls, stimulating the drones into thinking they're privileged to be working at IBM; hey, it's such a creative and interesting place. Kay does this at Apple, and I suppose Ted Nelson will do the same at Autodesk.

Kay coined the term Dynabook and described the product in a *Playboy* article in 1971, or whenever. Kay goes beyond the programmer's inability to finish his code: As far as I know, Kay is the master of not being able to finish his ideas. He's been honing his notions with creeping featurism as though the raw ideas were somehow a product. The advantage Kay and Nelson have over lesser known fellows at IBM and elsewhere is they maintain a high profile and can promote their ideas so other people can try to implement the ideas. Both idea men have the rare opportunity to take credit for the successful implementation of their ideas and the ability to criticize the failures without having to take responsibility. Hypertext products are cropping up all over, and a slew of Silicon Valley companies are working on Dynabook-like products. Kay and Nelson look good.

I like these two guys, but I think it's a shame that Nelson and Kay haven't been forced to do any real work. The twosome have been playing the same theme song for years and haven't done much more than hone their notions. This is typical of a Fellow at IBM or any high-tech firm. The Fellow will be the last guy to complain, because he's well paid and the job of cogitating isn't all that bad. The public suffers, though.

Let's put the brains in gear and get the country off its duff. Let's start by putting all these quasi-retired fellows back to work. ■



THINKS LIKE A DEC, PRINTS LIKE A DATASOUTH.

DEC is known for powerful systems.

Datasouth is known for powerful printers.

And now, your DEC and Datasouth's DS 400 make a powerful pair. Because the DS 400 is 100% code compatible with your

DEC system. So the VAX thinks you've got an LA 120 printer.

But what you've really got is pure Datasouth. Draft text at 400 cps, memo quality at 180 cps, and near letter quality at 60 cps. Plus dot-addressable graphics,

bar codes and OCR output.

You get a straight paper path for smooth forms handling. And the power to print multipart forms up to six layers thick. You also get Datasouth's 100% duty cycle, 24 hours a day. So you don't get any more emergency visits from the repairman.

If you've got a DEC system, and need a better printer, better get one that's on the same wavelength. Call 800-222-4528 to find your nearest Datasouth distributor.



Datasouth
AMERICA'S HIGH PERFORMANCE
PRINTER COMPANY

CIRCLE 234 ON READER CARD

P.O. Box 240947, Charlotte, NC 28224 • (704) 523-8500 • Tlx: 6843018, DASO UW • Sales: 1-800-222-4528 • Service: 1-800-438-5050 • West Coast Office: (415) 940-9828
DEC is a registered trademark of Digital Equipment Corporation.

RAF PRINT SERVER. 'THE ELIMINATOR!'

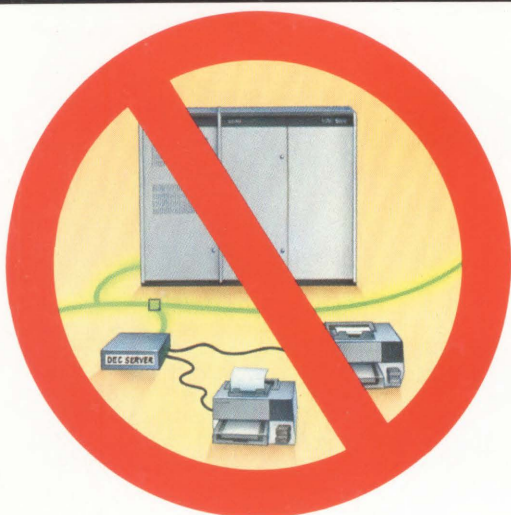

**INTRODUCING THE MOST COST-EFFECTIVE, EFFICIENT WAY
TO CONNECT PRINTERS TO YOUR VAX NETWORK.**



Datability presents RAF Print Server—a technological breakthrough that enables standard, local PC printers to act and serve as VAX network printers.

RAF Print Server changes the way a normal, locally connected printer operates, transforming it from a single-user PC printer to a shared access network printer, exactly as if the printer was hung from a terminal server instead of the PC. Best of all, your PC can continue to function as a regular PC because RAF Print Server works invisibly in the background.

RAF PRINT SERVER ELIMINATES THE NEED FOR TERMINAL SERVERS.

No longer do you need to use a terminal server to put a printer on your network. In a matter of minutes, your local PC printer can be transformed into a shared network printer, available to all VAX and PC users.

RAF PRINT SERVER ELIMINATES WIRING.

No longer is it necessary to run separate printer wiring in addition to your Ethernet cabling. A printer merely connects to the closest PC without any office disruption.

RAF PRINT SERVER ELIMINATES COSTLY EXPENDITURE.

With RAF Print Server, the cost per printer connection drops more than 40% for most installations. And you're assured the flexibility to connect additional printers to your network with even greater savings.

Economy. Efficiency. Flexibility. They add up to make RAF Print Server a product that's simply unmatched in the marketplace.

DATABILITY

1-800-DIAL-DSS

In New York: (212) 807-7800

Datability Software Systems, Inc.

322 Eighth Avenue, New York, NY 10001

All product names are registered trademarks of their respective manufacturers.

CIRCLE 114 ON READER CARD