



Intel[®] Integrated RAID Controller SRCS14L

Four-port Low Profile Serial ATA RAID Controller
Technical Product Specification, Version 1.0

November 2002



Information in this document is provided in connection with Intel® products. No license, express or implied, by estoppel or otherwise, to any intellectual property rights is granted by this document. Except as provided in Intel's Terms and Conditions of Sale for such products, Intel assumes no liability whatsoever, and Intel disclaims any express or implied warranty, relating to sale and/or use of Intel products including liability or warranties relating to fitness for a particular purpose, merchantability, or infringement of any patent, copyright or other intellectual property right. Intel products are not intended for use in medical, life saving, or life sustaining applications.

Intel may make changes to specifications and product descriptions at any time, without notice.

The Intel SRCS14L RAID controller may contain design defects or errors known as errata which may cause the product to deviate from published specifications. Current characterized errata are available on request.

Contact your local Intel sales office or your distributor to obtain the latest specifications and before placing your product order.

Copies of documents which have an ordering number and are referenced in this document, or other Intel literature may be obtained by calling 1-800-548-4725 or by visiting Intel's website at <http://www.intel.com>.

Copyright © Intel Corporation, 2002

i960, FlashFile, and Intel are trademarks or registered trademarks of Intel Corporation or its subsidiaries in the United States and other countries.

*Other names and brands may be claimed as the property of others.

Contents

1	Introduction	5
1.1	Acronyms	5
1.2	Documentation Conventions	6
1.3	Product Overview	6
1.4	Operating System Support	6
1.5	List of Features.....	6
2	Hardware	8
2.1	Physical Layout	8
2.2	Major Components	8
2.2.1	Intel® 80303® Intelligent I/O Processor	8
2.2.2	Intel® Smart 3 FlashFile™ Flash Memory	9
2.2.3	SDRAM (Cache).....	9
2.2.4	SATA Controllers.....	9
2.2.5	Audible Alarm	9
2.2.6	SATA Connectors.....	10
2.2.7	PCI Interface	10
2.2.8	SRCS14L Jumpers.....	10
2.2.9	Diagnostic Features	11
2.3	Architecture Features (HW).....	13
2.4	Electrical Characteristics	13
2.5	Environmental Specifications	13
2.6	Supported Hard Drive Technology	13
3	Software	14
3.1	Software Architecture Overview	14
3.1.1	User Interface	15
3.1.2	System Management	15
3.1.3	Common Layers	16
3.1.4	RAID Firmware.....	16
4	RAID Functionality and Features	17
4.1	Hierarchy	17
4.1.1	Level 1: Physical Drives	17
4.1.2	Level 2: Logical Drives	17
4.1.3	Level 3: Array Drives	17
4.1.4	Level 4: Host Drives	18
4.1.5	RAID Host/Array Drive Statuses	19
4.1.6	Logical Drive Statuses	20
4.1.7	RAID Controller Drive Limitations (Host, Array, Logical, and Physical) ..	20
4.2	Utilities and Tools	21
4.3	RAID Features.....	22
4.3.1	RAID Level Support.....	22
4.3.2	Caching	22
4.3.3	Hot Fix (Spare) Disks	24
4.3.4	Auto-detection of Hot-Plug Disk Drives in a Non-Intelligent Drive Enclo- sure	25

	4.3.5	Auto-declare Hot Fix (Spare) Drive	25
	4.3.6	RAID Array Drive Roaming	25
	4.3.7	On-line RAID Array Configurations	25
	4.3.8	Background Initialization and Instant Availability.....	27
	4.3.9	PCI Hot Plug	27
5		Certifications and Supported Technologies.....	28
	5.1	OS Certifications	28
	5.2	Electronic Regulatory Agencies Certifications (Hardware)	29
	5.3	Supported Specifications and Standards	31
6		Technical Drawings and Diagrams.....	32
7		Appendices.....	33
	7.1	Referenced Documentation	33
	7.2	BIOS Boot Messages.....	33

Figures

1	SRCS14L RAID Controller Physical Layout.....	8
2	Jumper Settings and Pin Numbers	10
3	LED Labels and Colors	11
4	RAID Software Stack Architecture Block Diagram.....	14
5	Controller PBA Drawing, Front View	32
6	Controller PBA Drawing, Back View	32

Tables

1	Common Acronyms.....	5
2	Controller Jumper Settings.....	11
3	LED Descriptions	11
4	Beep Sequences.....	12
5	Hardware Architecture	13
6	Electrical Specifications	13
7	Environmental Test Results	13
8	Host Array Drive Statuses.....	19
9	Logical Drive Statuses	20
10	RAID Controller Drive Maximum Limitations (SRCS14L)	20
11	Utilities And Tools	21
12	Supported RAID Levels.....	22
13	Supported Cache Settings	23
14	Example of a 9GB Pooled Hot Fix Drive Selected to Protect Four Raid Array Drives	24
15	OS Certification Requirements.....	28
16	Electronic Equipment Regulatory Certifications	29
17	Supported Standards and Specifications	31
18	Referenced Documentation	33

Introduction

1

1.1 Acronyms

The following acronyms may be used throughout this document.

Table 1. Common Acronyms (Sheet 1 of 2)

Acronym	Description
API	Application Programmer Interface
DLL	Dynamic Linked Library
DOS	Generic term to reference either MS-DOS* or ROM-DOS
DMI	Desktop Management Interface – a system management specification
ECC	Error Correction Code (also <i>error correcting code and error correcting circuits</i>)
FRU	Flash Recovery Utility
FUU	Flash Update Utility
FW	Firmware
Gb	Gigabit
GB	Gigabyte
HBA	Host Bus Adapter
IIR	Intel Integrated RAID
Kb	Kilobit
KB	Kilobyte
LVD	Low Voltage Differential SCSI
Mb	Megabit
MB	Megabyte
PCB	Printed Circuit Board
PCI	Peripheral Component Interconnect
RAID	Redundant Array of Independent Disks
SAF-TE	SCSI Accessed Fault Tolerant Enclosure
SATA	Serial AT Attachment
SE	Single Ended SCSI device. SCSI device type.
SCA	Single Connector Attachment - 80-pin SCSI connector on hot-swappable SE and LVD hard disks.
SCSI	Small Computer Systems Interface
SNMP	Simple Network Management Protocol

Table 1. Common Acronyms (Sheet 2 of 2)

Acronym	Description
StorCon	Storage Console: A character-based, menu-driven tool used for setting up, monitoring and maintaining mass storage device subsystems based on IIR Controllers.
StorCon+	Storage Console Plus: A GUI-based, menu-driven tool used for setting up, monitoring and maintaining mass storage device subsystems based on IIR Controllers. Runs only on Microsoft® Windows®-based systems.
XROM	PCI Expansion ROM - BIOS utility accessed at system POST.

1.2 Documentation Conventions

The terms “RAID controller” and “the controller” are used interchangeably throughout this document. Each term represents the physical PCB that integrates all the components of the RAID PCI add-in card.

1.3 Product Overview

The SRCS14L is a PCI-based, low-profile, four-port SATA RAID controller. It utilizes the Intel® 80303 Intelligent I/O processor, two Silicon Image® Sil3112A SATA controllers, and Intel Integrated RAID software.

1.4 Operating System Support

The following operating systems are fully validated and supported:

- Microsoft® Windows® XP Professional
- Microsoft Windows 2000 Advanced Server
- Red Hat® Linux® 7.3 (2.4 kernel)
- SuSe® Linux 8.0 Professional

The following operating systems are supported with limited compatibility validation:

- Windows 2000 Server
- Red Hat Linux 7.2
- TurboLinux® 7.0 Server

1.5 List of Features

- Supports RAID levels 0, 1, 4, 5 and 10
- Supports up to four hard drives connected to the four SATA ports on the controller
- Online RAID level migration and capacity expansion without reboot
- RAID array roaming



- Instant availability and background initialization
- Automatic rebuild with private (dedicated) or pooled (global) hot fix (spare) drives
- Variable data strip size configurable per array
- 64MB of ECC SDRAM support
- Read/write controller caching
- Hot plug disk drive auto detection configurable for non-intelligent enclosures
- PCI Hot plug support

Hardware

2

2.1 Physical Layout

Figure 1. SRCS14L RAID Controller Physical Layout

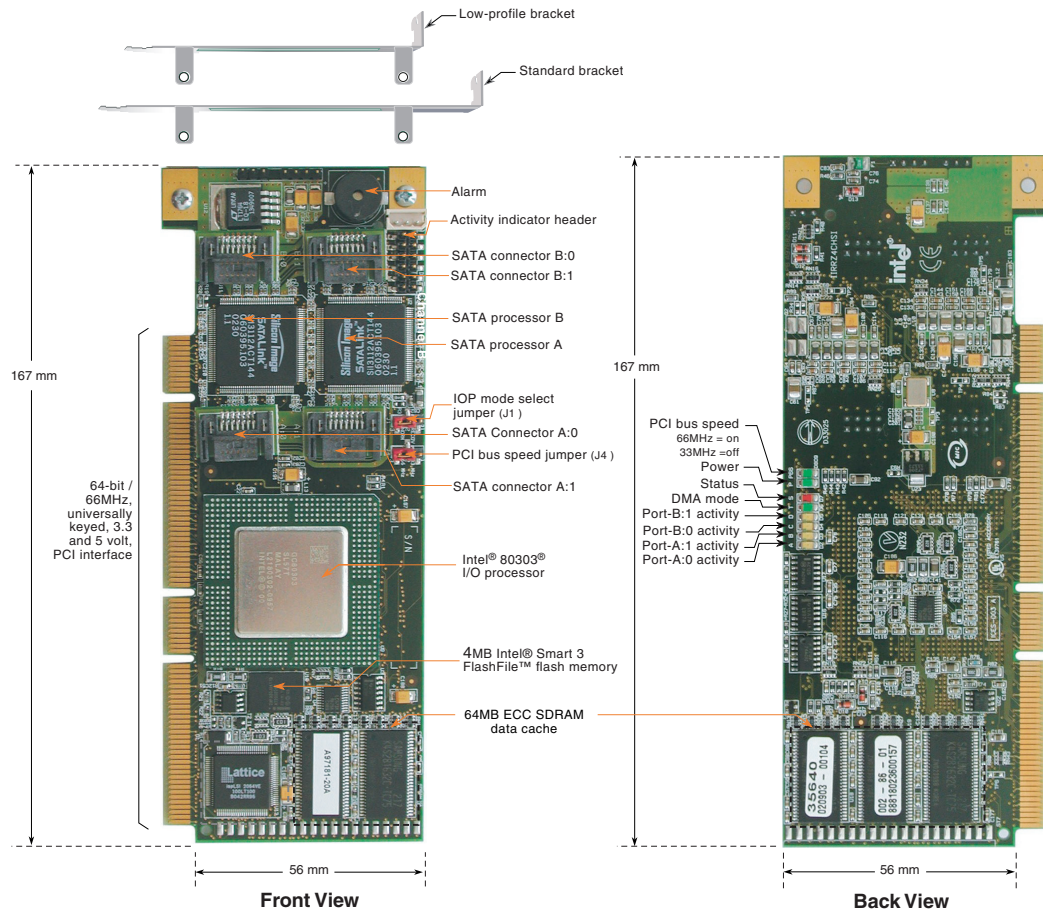

2.2 Major Components

2.2.1 Intel® 80303® Intelligent I/O Processor

The SRCS14L features the Intel® 80303® I/O processor. The core processor, PCI-to-PCI bridge, and Memory Controller are particularly useful in RAID applications. For more information on the Intel 80303 memory controller unit, visit <http://developer.intel.com/design/iio/docs/iop303.htm>.

2.2.1.1 Processor Core

The 80303 uses the 80960JT-100 core. The core processor runs at 100 MHz with an internal 64-bit 100 MHz PCI bus. Among other features, it contains a 128-bit register bus, 16Kbyte two-way instruction cache, 4Kbyte direct-mapped data cache, 1Kbyte zero wait state data RAM, and single clock execution of most instructions.

2.2.1.2 PCI-to-PCI Bridge

The PCI-to-PCI bridge features fully independent PCI bus operation with independent clocks, dedicated data queues, 32-bit/33Mhz and 64-bit/66Mhz PCI bus support, and 64-bit Dual Address Cycle addressing.

2.2.1.3 Memory Controller Unit

The Memory Controller provides direct control of memory systems external to the 80960 core processor, including SDRAM and Flash. It features programmable chip selects, a wait state generator, ECC single-bit correction and double-bit error detection. The bus interface to the memory controller operates at 100 MHz. The SRCS14L uses 64MB of embedded memory.

2.2.2 Intel® Smart 3 FlashFile™ Flash Memory

This 3.3v, 32Mb (4MB) flash memory chip is used to store the RAID firmware. This non-volatile storage can be accessed for firmware updates and recovery. For firmware recovery, set the IOP mode select jumper J1 to reset; place jumper on pins 1 and 2. For normal firmware updates, place the jumper on pins 2 and 3 (or remove totally). See [Figure 2: Jumper Settings and Pin Numbers](#) for more information.

2.2.3 SDRAM (Cache)

The SRCS14L provides 64MB of 3.3v PC-100 ECC unbuffered CAS 2 latency SDRAM. The memory is embedded in the RAID controller and is not upgradeable. It is connected directly to the memory controller interface bus of the IOP, and serves as storage for the executable code transferred from the flash. It also serves as cache during RAID transactions. Cache mode selection takes immediate effect while the server is online. The IOP memory controller provides single-bit ECC error correction.

2.2.4 SATA Controllers

The SRCS14L has two Silicon Image Sil3112A SATA controllers, which each control two serial ports (four ports total). The Sil3112A can support data transfer rates up to 1.5 Gbps. See <http://www.siliconimage.com/products/sii3112.asp> for more information.

2.2.5 Audible Alarm

An 80db audible alarm is mounted on the RAID controller to alert the user to a number of software and/or hardware events experienced by the controller.

2.2.6 SATA Connectors

The SRCS14L provides four SATA signal connectors.

2.2.7 PCI Interface

The SRCS14L has a 64-bit/66MHz PCI interface. The PCI connector is universally keyed for 3.3v or 5v signaling and is PCI 2.2 compliant. The controller is designed for optimal performance when inserted in a 64-bit/66MHz PCI expansion slot; however, it is backwards compatible with all 33MHz PCI expansion slots.

2.2.8 SRCS14L Jumpers

The IIR controller normally comes ready to be installed into the computer motherboard immediately. However, jumper settings are available to:

- Reprogram the RAID firmware that is located in the flash memory of the IIR controller.
- Set the PCI bus speed (force 33 MHz or auto-negotiate 33/66 MHz).

For jumper locations and settings, see [Table 2: Controller Jumper Settings](#) and [Figure 2: Jumper Settings and Pin Numbers](#).

Figure 2. Jumper Settings and Pin Numbers

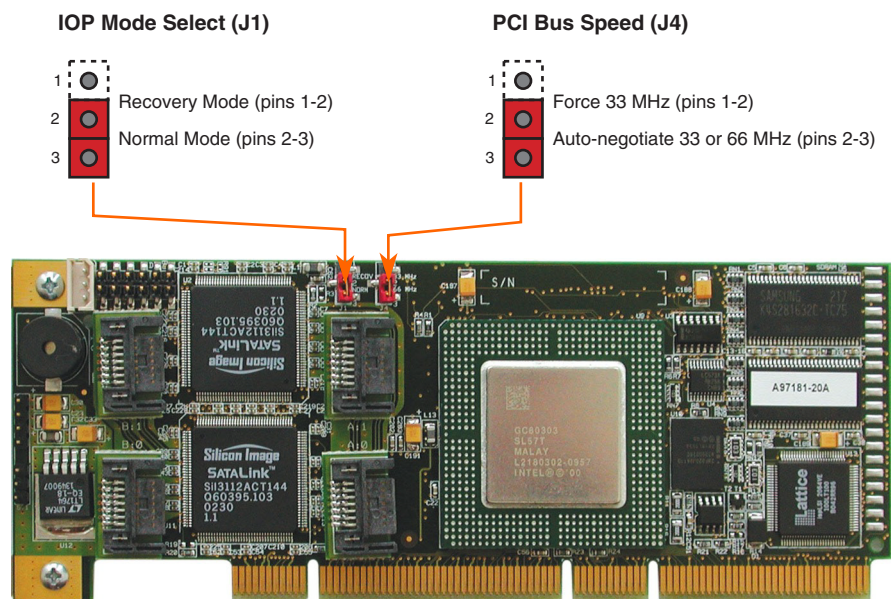

Table 2. Controller Jumper Settings

Jumper Block	Jumper Position	Definition
J1	Jumper on pins [1-2]	IOP is in reset mode with firmware recovery enabled.
	Jumper on pins [2-3]	IOP is in normal run mode.
	No jumpers	IOP is in normal run mode.
J4	Jumper on pins [1-2]	PCI bus is forced to 33 MHz.
	Jumper on pins [2-3]	PCI bus auto-negotiates 33 MHz or 66 MHz.
	No jumpers	PCI bus auto-negotiates 33 MHz or 66 MHz.

J1 - IOP mode select jumper block: This jumper is used to place the IOP in reset, which enables the flash chip to be programmed to recover resident firmware (FW). This is only necessary if the content of the flash part is corrupted and needs to be erased and reprogrammed. The jumper is installed on pins 1-2 to enable this function. During normal operation and during normal firmware updates, the jumper is installed on pins 2-3 (or removed totally).

J4 - PCI bus speed: Leave this jumper in the default position (pins 2-3 to auto-negotiate 33/66 Mhz) unless instructed to do otherwise by customer support or a specification update.

2.2.9 Diagnostic Features

The SRCS14L has LED indicators and audible beep sequences at startup to help you understand the status of the controller.

Figure 3. LED Labels and Colors

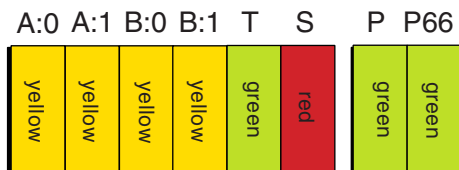

Table 3. LED Descriptions

LED	Description
A:0	Indicates activity on SATA port A:0.
A:1	Indicates activity on SATA port A:1.
B:0	Indicates activity on SATA port B:0.
B:1	Indicates activity on SATA port B:1.
T	Indicates data transfer to the controller's cache memory.
S	When illuminated, the controller's IOP is in reset mode.
P	When illuminated, the controller card is powered on.
P66	When illuminated, PCI bus frequency is 66Mhz. When not illuminated, PCI bus frequency is 33Mhz.

Table 4. Beep Sequences

Beep Sequence	Meaning
beep - pause - beep, beep, beep	Controller startup was successful.
beep, beep, beep, beep,	RAID controller has a problem. A possible cause is disk failure. To diagnose the problem, run the Storage Console to check the status of the RAID controller and array.
beep, beep - pause - beep, beep - pause -	Memory or firmware may have a problem. More details may be available from the boot message. If necessary, use the FRU utility to recover the firmware as described in <i>Appendix A</i> of the SRCS14L hardware guide.

2.3 Architecture Features (HW)

Table 5. Hardware Architecture

Component	Features
I/O Microprocessor	The 80303 processor: 100MHz, RISC 64-bit core
Cache Memory	3.3V unbuffered, PC100, ECC SDRAM. 64MB embedded not upgradeable
Flash Memory	3.3v, 32Mb (4MB) flash memory chip is used to store the RAID firmware
I/O interface (PCI)	PCI 2.2 compliant, universally keyed for 3.3 and 5 volt PCI slots
PCI Transfer Rate	528 MB/sec (Burst) DMA to PCI and local buses
PCI Signaling	+5 or +3.3 volt
SATA controllers	Two Silicon Image Sil3112A SATA controllers, which each control two serial ports (four ports total) with speeds up to 1.5 Gbps

2.4 Electrical Characteristics

Table 6. Electrical Specifications

Attribute	Measurements
Voltage Requirements	+3.3 or +5 Volts (all +/- 5% tolerance)
Power Consumption	+5 Volts @ 0.25 Amps = 1.25W +3.3 Volts @ 2.5 Amps = 8.25W

2.5 Environmental Specifications

Table 7. Environmental Test Results

Environmental Stress Test	Meets Required Conditions
Operating Temperature	0° C to +55° C
Storage Temperature	-40° C to +70° C
Form Factor (physical dimensions)	Height: 56mm Length: 167mm

2.6 Supported Hard Drive Technology

The RAID controller supports up to 4 hard disk drives connected to the 4 SATA ports. These hard drives must be compliant with the SATA specification 1.0.

Software

3

3.1 Software Architecture Overview

Figure 4. RAID Software Stack Architecture Block Diagram

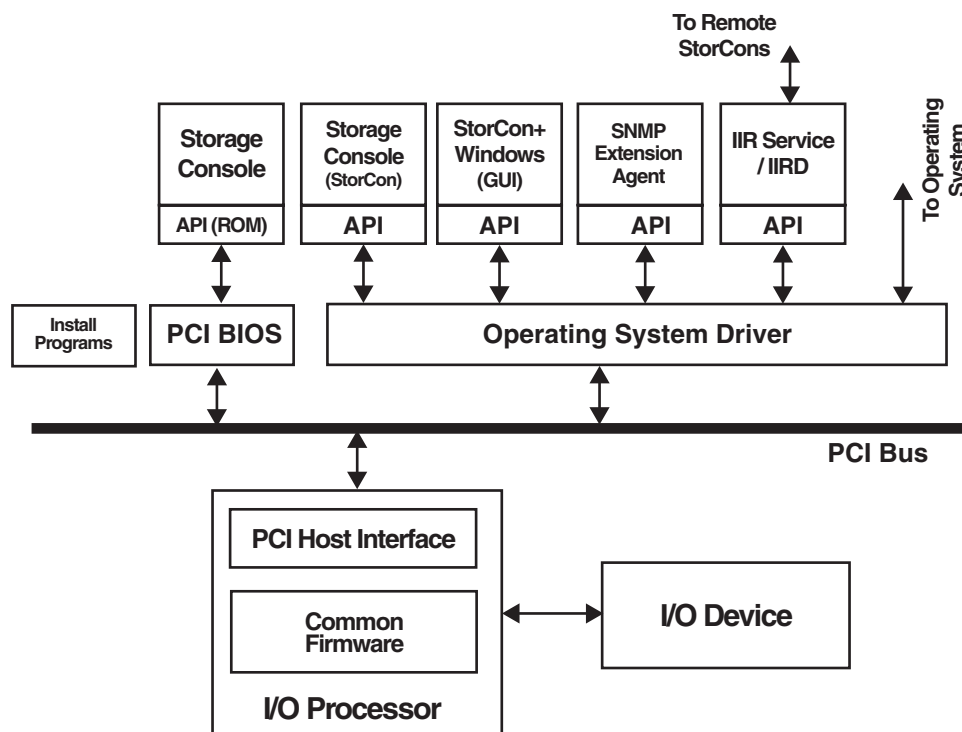

The RAID software stack is composed of two major component groupings: the *RAID firmware* embedded in the Flash memory and a set of *host resident drivers* and utilities installed on the host system. All host-based software contains an OS dependent portion and an OS independent portion. This allows for a consistent ‘look and feel’ across operating system platforms. A simple, custom messaging protocol is used to communicate between the host driver or utility and the embedded RAID firmware. The firmware is independent of the OS, I/O processor, and I/O bus through the use of abstraction layers. This layered RAID software executes on a custom, multi-tasking, real-time software executive and relies on the reuse of internal software communication ‘building blocks’ to incorporate new technology and provide for new products.

Note: The architecture block diagram in [Figure 4: RAID Software Stack Architecture Block Diagram](#) is a generalization. Its goal is to cover all OS implementations. Certain blocks may or may not be relevant to each specific OS.

3.1.1 User Interface

3.1.1.1 Storage Console

The Storage Console is a text-based user interface. It is a full-featured monitoring and configuration utility for managing all aspects of the RAID subsystem as well as many features of the RAID controller. It can be accessed via two methods. The first is during system boot time when entering the controller's BIOS by depressing the <Ctrl>+<G> keys when prompted. The utility accesses the RAID subsystem via the PCI BIOS.

The other method of accessing the Storage Console is via launching the application from within the host operating system.

Storage Console communicates with the firmware via a common API both during system POST and from within the host OS. This unique feature allows for a common user interface (UI) between both OS and pre-OS environments.

3.1.1.2 Storage Console+

Storage Console+ provides a graphical user interface (GUI) for the Storage Console. However, it runs only on Microsoft Windows-based systems and has the same features and functionality with only a few exceptions.

3.1.2 System Management

3.1.2.1 RAID Mail Utility

The RAID Mail utility provides the RAID subsystem the ability to send notifications of specific IIR events to remote computer stations. This utility takes certain messages generated by the RAID Configuration Service and converts them into standard mail messages (for Windows NT/9x/200/XP, in MAPI format). It relies on the IIR API for communication to the IIR specific information. It can send messages locally (pop-up messages on local monitor) or to specific remote workstations. It also can interface with standard email applications (like Microsoft Outlook or Exchange) installed on the local system.

3.1.2.2 SNMP Extension Agent

The SNMP Extension Agent is the interface between SNMP and the IIR Management Information Base (MIB). It interacts with the host resident MIB as well as the IIR HBA (via the IIR API) to respond to SNMP requests.

3.1.3 Common Layers

3.1.3.1 PCI BIOS

The PCI BIOS is the Expansion ROM software as defined in the PCI specification. It performs IIR initialization from host system memory during POST.

3.1.3.2 IIR API

The IIR API is a C++ class library consisting of OS-independent classes and methods. This layer encapsulates sequences of lower level C library API functions and builds OS independent data structures used for communicating with the HBA. This API relies on an OS dependent layer that communicates with the local driver (if one is present) or a remote driver via the TCP/IP or IPX/SPX network protocol.

3.1.3.3 Operating System Driver

The IIR device driver is the OS specific driver that communicates between the host resident application and the IIR HBA using the IIR communications protocol.

3.1.3.4 RAID Configuration Service

The *IIR Service / IIRD* allows remote access to the IIR HBA. It runs as a service on Windows-based systems and as a daemon on Unix-based systems. In order to use the remote access capability, an administrator has to create user accounts. The passwords for these accounts are encrypted for security.

3.1.4 RAID Firmware

The IIR firmware is composed of multiple software layers allowing for maximum flexibility, re-use and maintainability. At the highest level is a host interface abstraction layer in the common firmware that is also composed of multiple internal layers of service and library modules.

The I/O Device pictured next to the firmware ([Figure 4: RAID Software Stack Architecture Block Diagram](#)) also communicates over an abstraction layer allowing for elegant integration of multiple I/O device types from different vendors.

RAID Functionality and Features

4

4.1 Hierarchy

A fundamental purpose of a RAID system is to present a usable (with some level of redundancy) data storage medium (or drive) to a host operating system. In accomplishing this, the Intel RAID firmware is based on a four level hierarchal model. Each level has its own drives associated with it. The basic rule is to build drives on a given level in the hierarchy; the drives of the next lower level are used as components. So, in order to create a data drive (host drive/RAID volume) and present it to the host operating system, the RAID firmware typically follows these steps:

1. One or more physical drives are selected and initialized
2. A logical drive is created for each physical device
3. The logical drives are grouped and an array drive is created
4. The RAID firmware designates the array drive as a host drive and presents it to the host OS

4.1.1 Level 1: Physical Drives

Physical drives are located on the lowest level of the hierarchy. This includes hard disk drives, removable hard disks, and some Magneto Optical drives. They are the basic components of all drive constructions. However, before they can be used by the firmware, these hard drives must be prepared by a process called initialization. During initialization each hard disk has configuration information written to its physical medium in non-user accessible redundant areas. This information allows a univocal identification even if the disk-ID or the controller is changed. For reasons of data coherency, this information is extremely important for any drive construction consisting of two or more physical drives.

4.1.2 Level 2: Logical Drives

Logical drives are constructed to obtain full independence of the physical coordinates of a physical device. This is important because it allows one to rearrange the disk-IDs and channel location of the physical drives of a disk array without compromising the integrity of the RAID array disk. It also is what allows you to interchange disk arrays between compatible controllers.

You can create a logical drive manually by using one or more available physical drives. A logical drive created manually in this way is presented directly to the host OS as a Host drive (see [host drives in Level 4](#)). However, it is not associated with any array drive (see [array drives in Level 3](#)).

4.1.3 Level 3: Array Drives

Array drives are located at this level in the hierarchy. Array drives always consist of logical drives and consist of the following drive types:

- RAID 0 drives
- RAID 1 drives

- RAID 4 drives
- RAID 5 drives
- RAID 10 drives

You can manually create an array drive by using two or more logical drives that were manually created at level 2. This action combines the original host drives associated with each of the logical drives into a single host drive at a chosen RAID level.

4.1.4 Level 4: Host Drives

Host drives (RAID volumes) are created at the highest level of the hierarchy by the RAID firmware. This is done automatically upon the creation of an array drive. It is also done automatically upon the manual creation of a logical drive. Each host drive is assigned a drive number that matches the drive number of its array drive or logical drive. Host drives are the only hierarchical level drives that are detectable by the host operating system. The three lowest level hierarchical drives are transparent to the host operating system.

After a capacity expansion of a given array drive, the added capacity appears to the host OS as a new host drive on this level. It can then be configured as a separate host drive or, using the *'Merge'* feature in the *Host Drive* menu, be combined with the initial host drive of the array drive into one single host drive.

Warning: Any data located on the new host drive (created from the capacity expansion) will be lost using the Merge feature. Do not use this feature if the new host drive already contains data that you do not wish to destroy.

Within the Storage Console utility, each level of hierarchy has its own special menu:

Level 1 → Menu: **Configure Physical Devices**

Level 2 → Menu: **Configure Logical Drives**

Level 3 → Menu: **Configure Array Drives**

Level 4 → Menu: **Configure Host Drives**

4.1.5 RAID Host/Array Drive Statuses

Table 8 lists the available states of RAID Host and Array Drives.

Table 8. Host Array Drive Statuses

Drive Status	Attribute	Drive Type	Redundant	Description
Idle	RW	RAID 4 / 5 / 10	No	Newly defined array prior to build process starting.
Build	RW	RAID 1 / 4 / 5 / 10	No	The initial process of configuring redundancy information upon creation of drive.
Ready	RW	RAID 1 / 4 / 5 / 10	Yes	The array drive is fully operational, its normal state.
Rebuild	RW	RAID 1 / 4 / 5 / 10	No	Array drive assumes this status after the automatic activation of a Hot Fix or after manual replacement (hot plug).
Expand	RW	RAID 4 / 5	Yes when adding new drives. No when using free space.	This status indicates that the RAID level and or capacity are (is) being migrated. The Expand status combines with the Ready and Fail statuses as shown below: <ul style="list-style-type: none"> • Ready/Expand • Fail/Expand
Fail	RW	RAID 1 / 4 / 5 / 10	No	This status indicates that a <i>logical drive</i> has failed.
Error	RO	RAID 4 / 5 / 10	No	This status indicates that more than one logical drive has failed. In this event, the array is set to read only.
Patch	RW	RAID 4 / 5	Yes	This status indicates that the array drive has gone through a significant procedure or has been patched from the error status to fail status. The Patch status combines with other statuses as shown below: <ul style="list-style-type: none"> • Ready/Patch • Fail/Patch • Error/Patch • Idle/Patch • Rebuild/Patch
RW = Read Write RO = Read Only			The drive <i>attribute</i> indicates the level of host OS access to the drive	

4.1.6 Logical Drive Statuses

Table 9. Logical Drive Statuses

Drive Status	Attribute	Description
Ready	RW	The drive is operational and functioning normal.
Missing	-	The drive is missing or no longer detected by the RAID controller.
Fault	RW	The drive is no longer operating within expected parameters.
RW = Read Write RO = Read Only		The drive <i>attribute</i> indicates the level of host OS access to the drive.

4.1.7 RAID Controller Drive Limitations (Host, Array, Logical, and Physical)

The following are limitations assuming the following:

- Four SATA ports
- Cabling that meets SATA specifications 1.0

Physical drives are limited by the number of ports (four) on the RAID controller. Each physical drive must be connected to one of the SATA ports. The maximum number of **array drives** is two. A RAID array drive requires a minimum of two hard disk drives (or logical drives). Therefore the maximum RAID array drive limitation for the SRCS14L controller is the physical drive limit divided by two.

Each RAID array drive (up to two) can contain up to a maximum of two **host drives**. This means that the SRCS14L controller has a maximum limitation of four host drives. Also, each array drive must have at least one host drive. A host drive can only be associated with (or reside on) a single array drive.

Table 10. RAID Controller Drive Maximum Limitations (SRCS14L)

Drive Type	Per RAID Controller	Per Array Drive	Per Host Drive
Physical Disk Drives	4	4	4
RAID Array Drives	2	N/A	1
RAID Host Drives	4	2	N/A

4.2 Utilities and Tools

Table 11. Utilities And Tools

Management/Monitoring	Description	Actions
Storage Console (StorCon)	This is a text-based UI that allows full management and monitoring of the RAID controller and its subsystem. Consistent look and feel across all supported operating systems.	<ul style="list-style-type: none"> Can be launched during Boot up, <Ctrl>+<G>, or within host OS Can be run locally or remotely using TCP/IP or SPX/IPX network protocols.
Storage Console+ (StorCon+)	GUI based version of the Storage Console with exception to a few functions. It only runs locally on Windows servers and clients.	<ul style="list-style-type: none"> Can be run locally or remotely using TCP/IP or SPX/IPX network protocols.
Monitoring/Reporting	Description	Actions (using StorCon text-based)
View Statistics	Allows the viewing of I/O activity of host, logical, and physical drives and cache activity	From the menu, choose Express or Advanced Setup -> View Statistics. User can adjust synch rate and enable and disable logging.
View Events	Allows the viewing and saving of all events regarding the controller since it's last boot up.	From the menu, choose Express or Advanced Setup -> View Events.
View Hard Disk Information	Lists all hard drives connected to the RAID controller with information about each hard drive	You can select each drive individually to bring up a detailed list of information that includes detected defects since the drive was first detected by the RAID controller.
Diagnostics	Description	Actions (using StorCon text-based)
Save Information	Gives administrator the ability to save the configuration information of the RAID controller in ASCII file for viewing.	User can save file to be used for troubleshooting or documentation.
Memory Test	Non-destructive tests are written to ECC memory and verified. The different modes determine type of pattern and quantity. Tests are not non-destructive for non-ECC memory.	From the menu, choose Advanced Setup -> Configure Controller -> Controller Settings. User selected options are: No test, Standard, Double scan, and Intensive.
Parity Verify	Selecting this feature causes the controller to verify the parity on RAID level 4 and 5 arrays.	From the menu, choose Advanced Setup -> Configure Array Drives -> Select an array.
Check Surface: Physical Disks	A destructive surface-check of the selected hard disk drive. The controller writes and reads certain data patterns and checks them for correctness.	From the menu, choose Advanced Setup -> Configure Physical Devices -> Select Physical Drive -> Check Surface. Warning! This action destroys all data on the selected drive.

Table 11. Utilities And Tools

Firmware	Description	Actions
Firmware Update	Utility that allows the updating of the controller's firmware using: <ul style="list-style-type: none"> DOS utility for major updates (e.g. major, 2.32.xx to 2.33.xx) or StorCon for minor updates (e.g. minor, 2.32.xx to 2.32.yz). 	<ul style="list-style-type: none"> Is accessed via DOS utility Is accessed via the Storage Console during boot up (<Ctrl>+<G>) or from within the host OS menu Advanced Setup -> Configure Controller -> Firmware Update
Firmware Recovery	Utility to recover from corrupted firmware.	Requires that the controller's J4 jumper be placed in the <i>Reset/ Firmware Recovery</i> mode and the use of the DOS-based firmware recovery utility.

4.3 RAID Features

4.3.1 RAID Level Support

Table 12. Supported RAID Levels

RAID Level	Description	Drives Requirements
0	Data striping. The SRCS14L can support only one RAID 0 component.	2 min, 4 max
1	Drive mirroring.	2 min, 4 max
4	Data striping with dedicated parity drive.	3 min, 4 max
5	Data striping with distributed parity.	3 min, 4 max
10	Combination RAID 0 and 1, striped mirrors. The SRCS14L does not support the addition of a hot fix disk under RAID 10.	4 min, 4 max; drives must be added in pairs
Disk Pass-Through to Host		
Single Disk	Presented to host OS as a host drive.	1
Chaining	Presented to host OS as a host drive.	2 min, 4 max

4.3.2 Caching

There are two levels or modes of caching related to the controller - each independent of the other:

- Controller caching
- Disk drive caching

Caching can be enabled on the **controller**, which sets caching on all the RAID array/host drives configured on the controller. This mode of caching utilizes the memory that is located on the controller (SDRAM that is either embedded or an inserted DIMM module). The other caching mode is enabling the caching feature of the **hard disk drives**. In this method, the cache memory that is utilized is located on the disk drive and does not use the controller’s memory.

Warning: In the event of power loss to the computer system, data located in disk cache is not protected by the battery backup unit of those controllers that support optional battery backup. The battery backup only protects data that is located in the controller cache.

4.3.2.1 Controller Cache Selections

- Caching on/off selectable (sets all controller caching algorithms including Read Ahead to all on or all off)
- Delayed Write on/off selectable (Write Back)

4.3.2.2 Physical Disk Cache Selections

- Read cache on/off selectable
- Write cache on/off selectable

Table 13. Supported Cache Settings

	Cache Setting						Cache Configuration Description		
	Disk Cache			Controller Cache					
1	Write	_	Read	_	Cache	_	Delayed Write	•_	No cache
2	Write	_	Read	•	Cache	_	Delayed Write	•_	Disk Read
3	Write	•	Read	_	Cache	_	Delayed Write	•_	Disk Write
4	Write	•	Read	•	Cache	_	Delayed Write	•_	Disk Read Write
5	Write	_	Read	_	Cache	•	Delayed Write	_	Controller Read
6	Write	_	Read	•	Cache	•	Delayed Write	_	Disk Read, Controller Read
7	Write	•	Read	_	Cache	•	Delayed Write	_	Disk Write, Controller Read
8	Write	•	Read	•	Cache	•	Delayed Write	_	Disk Read Write, Controller Read
9	Write	_	Read	_	Cache	•	Delayed Write	•	Controller Read Write
10	Write	_	Read	•	Cache	•	Delayed Write	•	Disk Read, Controller Read Write
11	Write	•	Read	_	Cache	•	Delayed Write	•	Disk Write, Controller Read Write

Table 13. Supported Cache Settings

	Cache Setting				Cache Configuration Description
	Disk Cache		Controller Cache		
12	Write	• Read	• Cache	• Delayed Write	Disk Read Write, Controller Read Write
_ disabled/off Legend • enabled/on •_ either					

4.3.3 Hot Fix (Spare) Disks

There are two types of hot fix drives:

- **Private** (dedicated): This type of hot fix drive is assigned to a specific RAID 4, 5, or 10 array drive. It cannot be used by any other RAID array drive configured on the controller.
- **Pooled** (global): This type of hot fix drive is available for any RAID 1, 4, 5, or 10 array drive that has been configured with *Pooled Hot Fix Access* enabled.

When adding a Pool Hot Fix to a specific array, the access for this array will be automatically enabled, for other arrays this feature has to be manually activated with the Pool Hot Fix Access switch.

The capacities of Hot fix drives are required to be the same size or larger than the capacity of the smallest physical disk drive in the RAID array drives that they are protecting. Therefore, if you have two RAID arrays where *Array_1* has all 9 GB drives and *Array_2* has all 18 GB drives then *Array_1* would require, at a minimum, a 9 GB *hot fix drive* and *Array_2* would require, at a minimum, an 18 GB *hot fix drive*.

Also, when using a single *pooled hot fix drive* to protect several RAID array drives, the *pooled hot fix drive* must meet the proper capacity requirement to protect **all** of the arrays. To select the proper sized *pooled hot fix drive*, first determine the capacity of the smallest physical disk drive in each RAID array to be protected. Next, select a *pooled hot fix drive* that is equal to or larger than the capacity of the largest of these disk drives. For example, in Table 14, if the pooled hot fix drive for the four RAID arrays is 9GB, then it would only protect arrays 1 and 2. Therefore, the proper hot fix drive selection to protect **all** four of the array drives would have to be of a minimum capacity of 36GB (see note below).

Table 14. Example of a 9GB Pooled Hot Fix Drive Selected to Protect Four Raid Array Drives

Array (smallest disk)	Array_1 (4GB)	Array_2 (9GB)	Array_3 (18GB)	Array_4 (36GB)
Protected by Pooled Hot Fix?	Yes	Yes	No	No
Note: This is only an example of how the pooled hot fix drive feature works. Obviously it would not be practical to use only one pooled hot fix drive to protect all four of the arrays in this example unless hardware configuration limitation only allowed for one extra drive as a pooled hot fix (i.e. adding the pooled hot fix drive brings the total number of hard disk drives to the maximum supported by the controller).				

4.3.4 Auto-detection of Hot-Plug Disk Drives in a Non-Intelligent Drive Enclosure

This is a special feature that allows the use of non-intelligent disk enclosures (requires truly hot-pluggable disk drives and backplane connectors) as though they were intelligent enclosures. This feature is configurable and allows the user to set up non-intelligent enclosures to detect the insertion or removal of hot plug disk drives and report the event to the RAID firmware. The RAID configuration is automatically updated to the new configuration. Access this feature through the *Advanced Setup* menu of Storage Console.

4.3.5 Auto-declare Hot Fix (Spare) Drive

If the RAID controller has a RAID array drive that is in *failed (degraded) state*, and you connect to the controller a new hard disk drive that is the same size or larger than the smallest disk drive in that *failed (degraded) RAID array* then the RAID firmware will automatically mark this new disk drive as a *hot fix (spare) drive* for the *failed (degraded) RAID array drive*. *Rebuild* will then automatically commence. If the new hard disk is smaller than the smallest hard disk drive in the *failed (degraded) RAID array drive*, the new disk drive will not be marked as a spare and the *failed (degraded) RAID array drive* will remain *failed (degraded)*. When a non-intelligent enclosure that has not been configured for auto-detection of hot plug disk drives is used, a bus scan or reboot is required for the *Auto Declare Hot Fix* feature to commence.

4.3.6 RAID Array Drive Roaming

Array Roaming allows the user the ability to move a complete RAID array from one computer system (for example, computer #1) to another computer system (computer #2) and preserve the RAID configuration information and user data on that RAID array. Computer #2 must also have an SRCS14L controller installed. RAID arrays set up with an SRCS14L controller cannot roam to computers that use other controllers.

Note: For a migrated RAID array to be recognized by the new host operating system, the host system may need to be rebooted.

Warning: RAID arrays set up with an SRCS14L controller cannot roam to computers that use other controllers (anything other than the SRCS14L). Unpredictable behavior may include, but is not limited to, data loss or corruption.

4.3.7 On-line RAID Array Configurations

4.3.7.1 Capacity Expansion Without Reboot

On-line capacity expansion refers to the ability of the RAID controller to present new storage space to the host OS without requiring that the computer system must be taken off-line and rebooted (for those Operating systems that support this feature). The host OS is able to detect the new capacity and format and partition it for immediate use. The RAID controller offers several ways of creating additional capacity while on-line.

Creating new RAID array drives from available physical hard disk drive:

This is the simplest method. The user just creates a new *host drive* from available physical disk drives that are connected to the RAID controller (the assumption here is that there were disk drives that were already connected but unused or there were new disk drives inserted into open slots in a hot plug drive enclosure already connected to the RAID controller)

Creating new capacity to existing RAID array components (Expand Array Drive):

Using this method you are allowed to do one of the following:

- Convert unused free space on the existing logical drives of the RAID array drive into a separate host drive, or
- Add additional physical disk drives to the existing RAID array drive

4.3.7.2 RAID Level Migration

RAID level migration is accomplished using the *Expand Array Drive* feature. To expand a RAID 0 drive to a RAID 4 or 5, requires that you add at least one additional drive to the array. Migrating from RAID 4 or 5 to RAID 0 frees one disk. The RAID controller allows the following RAID level migrations of a given array drive:

RAID 0 → RAID 4: add new disk, parity is calculated and written to new disk

RAID 0 → RAID 5: add new disk, parity calculated and written to new disk, then parity is distributed over all disk

RAID 5 → RAID 0: parity written to one disk, parity disk freed and removed

RAID 4 → RAID 0: parity disk freed and removed

RAID 4 → RAID 5: parity distributed over all disk

RAID 5 → RAID 4: parity written to one disk

Basic migration process: RAID 0 <--> RAID 4 <--> RAID 5

To initiate a migration the RAID array must be have a status of *ready*.

4.3.7.3 Data Strip Size Configurable per RAID Array

The strip size for each RAID array can be configured at the time of creation of the RAID array. This is a one-time configuration and cannot be changed or migrated once the array has been created. For RAID 0, 4, 5, and 10 arrays the following Strip Sizes are possible:

- 16KB
- 32KB
- 64KB
- 128KB

4.3.8 Background Initialization and Instant Availability

The initialization of RAID array drives is done in the background. Array drives have a status of *build* during this process and are immediately accessible to the host OS if the host OS supports online capacity expansion.

There are two build modes available when creating RAID arrays, *Non-destructive* and *Destructive*. *Destructive* is much faster than the *standard* build mode. When in *destructive* build mode, the firmware writes a pattern of zeros across all disks. If this build process is interrupted by rebooting the computer, the build process will continue in the much slower *non-destructive build mode*.

4.3.9 PCI Hot Plug

The controller supports the PCI hot plug specification for Windows. It supports the *hot replace* function only.

Certifications and Supported Technologies

5

5.1 OS Certifications

The product will be validated with the latest vendor OS certification test suites. Pre-submission tests will be passed and the certifications listed in [Table 15](#) will be submitted to the proper submission process as required per OS. The pre-submission test will be run on the final gold production release candidate of the RAID software suite OS drivers and RAID firmware. The product will not be held up from shipping while awaiting final passing notification from the OS vendors (and in the case of Windows 2000, the digitally signed versions of the OS driver).

Table 15. OS Certification Requirements

OS Vendor	Details	Test Suite Version
Red Hat Linux	The product shall be certified to receive "Red Hat Ready" certification for the following: <ul style="list-style-type: none">• Red Hat Linux 7.3 (the 2.4 kernel)	Test suite ver. 1.6.9 or latest

5.2 Electronic Regulatory Agencies Certifications (Hardware)

Table 16. Electronic Equipment Regulatory Certifications

Country/Region	Applicable Specification	Agency Certifications	Product Labeling	Manual Statements
U.S.A. (EMC)	FCC part 2; FCC part 15, subpart B, Class A	Class A verification testing only. No laboratory accreditation required.	FCC Class A statement on product, product packaging, or prominently located in the users manual, as follows: This device complies with part 15 of the FCC Rules. Operation is subject to the following two conditions: (1) This device may not cause harmful interference, and (2) this device must accept any interference received, including interference that may cause undesired operation.	FCC Class A statements prominently located in users manual, as follows: Note: This equipment has been tested and found to comply with the limits for a Class A digital device, pursuant to part 15 of the FCC Rules. These limits are designed to provide reasonable protection against harmful interference when the equipment is operated in a commercial environment. This equipment generates, uses, and can radiate radio frequency energy and, if not installed and used in accordance with the instruction manual, may cause harmful interference to radio communications. Operation of this equipment in a residential area is likely to cause harmful interference in which case the user will be required to correct the interference at his own expense. Plus, the users manual shall caution the user that changes or modifications not expressly approved by Intel Corp. could void the user's authority to operate the equipment.
U.S.A. and Canada (safety)	UL Accessory Listing to UL60950, 3 rd ed. and CAN/CSA C22.2 No 60950-00	UL and UL-Canada safety certification	UL/UL-Canada Accessory Listing mark, includes Intel file no. E139761, and I.T.E. product category; UL pwb fabricator mark; and V-0 or V-1 flame rating mark.	No known UL required safety statements.
Canada (EMC)	ICES-003 Digital Apparatus, Class A. Note, FCC or CISPR 22:1993 limits accepted in lieu of ICES-003	Class A verification testing only. No laboratory accreditation required.	Industry Canada Class A statement on product, product packaging, or prominently located in the user's manual, as follows: This Class A digital apparatus complies with Canadian ICES-003. French version is optional, as follows: Cet appareil numérique de la classe (*) est conforme à la norme NMB-003 du Canada.	No additional statements.

European Union (EMC)	EN55022:1998 Class A (emissions)	Manufacturer's Declaration of Conformity (DoC) to the EMC directive. No laboratory accreditation required.	CE mark on board or alternately, CE mark on product packaging. Minimum 5mm in height.	Declaration of Conformity statement, plus CE mark, plus the following (including translations), This product follows the provisions of the European Directive 89/336/EEC (EMC) and Directive 73/23/EEC (Safety/LVD).
European Union (EMC)	EN55024:1998 (immunity), consists of IEC 61000-4-2 (ESD), IEC 61000-4-3 (radiated immunity), IEC 61000-4-4 (EFT), IEC 61000-4-5 (surge), IEC 61000-4-6 (conducted immunity), and IEC 61000-4-11 (voltage dips and interrupts)	Same as EN55022 (EMI) requirements above	Same as EN55022 (EMI) requirements above.	Same as EN55022 (EMI) requirements above.
European Union (safety)	EN 60950, 3 rd ed.	Manufacturer's Declaration of Conformity (DoC) to the Low Voltage directive. No laboratory accreditation required.	Same as EN55022 (EMI) requirements above.	Same as EN55022 (EMI) requirements above.
Australia, New Zealand (EMC)	AS/NZS 3458: 1995 (CISPR 22:1993), Class A	Manufacturer's Declaration of Conformity (DoC)	C-Tick mark with Intel supplier code no. (N232) on board or product packaging.	None.
Korea (EMC)	Nat'l standards w/ emissions based on CISPR 22:1997 and immunity based on CISPR 24 with EN 55024: 1998 type modifications	In-country testing required at an RRL (Radio Research Laboratory) accredited lab.	Korean MIC (Ministry of Information and Communication) logo mark on board or product packaging.	Korean MIC (Ministry of Information and Communication) logo mark plus Korean certification text
Taiwan (EMC)	CNS 13438 (CISPR22) Information Technology Equipment	Test at a BSMI accredited lab or an A2LA or NIST NVLAP accredited lab that is notified to BSMI by NIST	Taiwan registration DoC logo mark on board or product packaging.	Traditional Chinese BSMI Class A text in users manual.
Australia, New Zealand, Taiwan, Korea, other APAC (safety)	IEC 60950, 3 rd ed. (aka CB report w/ CB certificate)	Notified body test house required, e.g., UL, Nemko, etc.	None.	None.

5.3 Supported Specifications and Standards

Table 17. Supported Standards and Specifications

Specification/Standard	Details
BIOS Boot Specification ver 1.01	http://www.phoenix.com/PlatSS/PDFs/specs-bbs101.pdf
PnP BIOS Specification 1.0a	http://www.microsoft.com/hwdev/tech/pnp/default.asp
EI Torito CD-ROM Boot v1.0	<ul style="list-style-type: none"> The product supports booting from a CD-ROM based on the “EI Torito” Bootable CD-ROM Format Specification, version 1.0, http://www.phoenix.com/PlatSS/PDFs/specs-cdrom.pdf The product supports a bootable CD-ROM from a PCI 2.2 Plug and Play compliant BIOS. The product supports No Emulation mode with PnP BIOSs.
PCI BIOS 2.1	http://www.pcisig.com/specifications/pci_bios
PCI Power Management 1.1	http://www.pcisig.com/specifications/pci_bus_power_management_interface
PCI Local Bus Specification Rev 2.2	http://www.pcisig.com/specifications/conventional_pci
PCI Local Bus Specification Rev 2.2 Low Profile PCI card ECN	http://www.pcisig.com/data/specifications/reset_ecn1_011300.pdf (for members only)
Microsoft Hardware Design Guide Version 3.0	http://www.microsoft.com/hwdev/serverdg.htm#Design3
Power Management (ACPI and OnNow)	<ul style="list-style-type: none"> The product supports power states D0, and D3 as defined by Storage Device Class Power Management Reference Specification, Microsoft, Version 1.0A, February 1997. The product supports power state D3 as follows: <ul style="list-style-type: none"> Drive controller (i.e., interface and control electronics): not functional; context lost Interface mode (i.e., communications timings): not preserved Drive motor (i.e., spindle): stopped
POST Memory Manager Specification, Version 1.01	http://www1.phoenix.com/PlatSS/PDFs/specs-pmm101.pdf Note that compliance in this case does not mean usage of calls outlined in the spec. We do not use PMM calls however we do not violate the specification.
NetWare Peripheral Architecture (NWPA)	http://developer.novell.com/ndk/storarch.htm (Username and Password Required)
Silicon Image Sil3112	http://www.siliconimage.com/products/sii3112.asp
SATA 1.0 Specification 1.0	http://www.serialata.org/cgi-bin/SpecDownload.cgi
ATA/ATAPI-5	T13 1321D, Rev. 3, 29 February 2000
ATA/ATAPI-6 (for 48bit LBA support)	T13 1410D, Rev. 1e, 26 June 2001.

Technical Drawings and Diagrams 6

Figure 5. Controller PBA Drawing, Front View

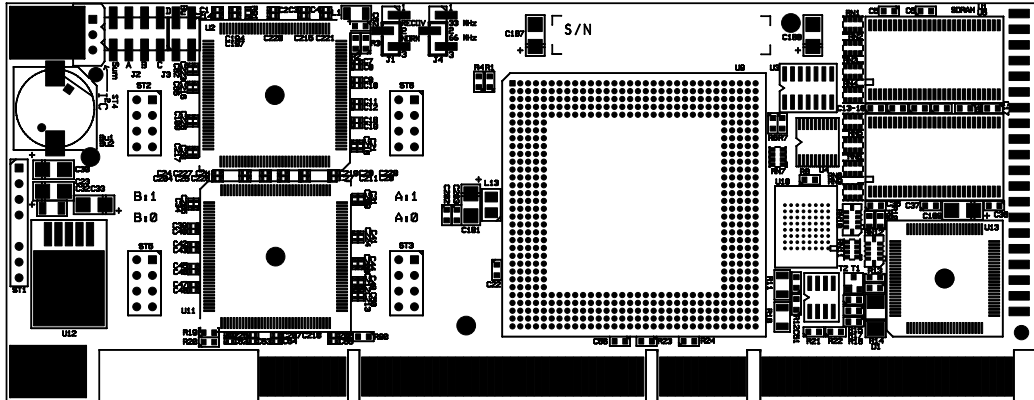
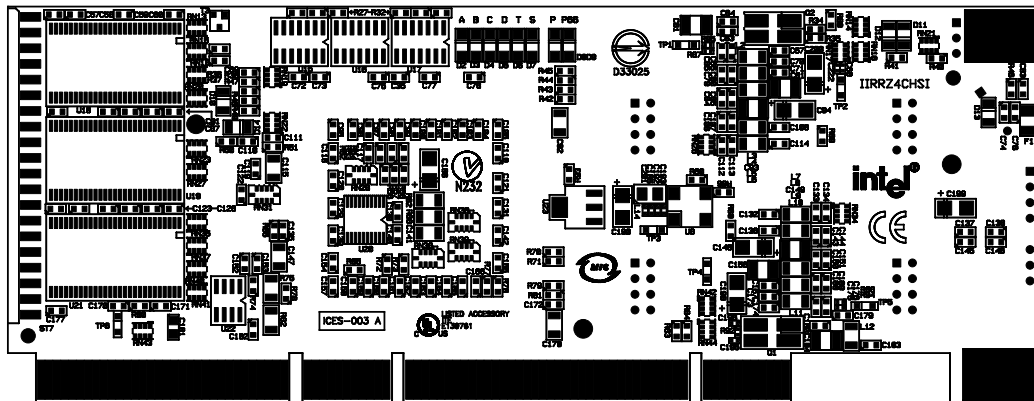

Figure 6. Controller PBA Drawing, Back View



Appendices

7

7.1 Referenced Documentation

Table 18. Referenced Documentation

Document Title	Order #
SRCS14L Hardware Installation and User's Guide	251554-001
Software Installation and User's Guide	273479-002

7.2 BIOS Boot Messages

TBD.