

Remote Annex

T1 Getting Started Guide

Part No. 166-024-851 Rev. A
January 1997



Copyright © 1997 Bay Networks, Inc.

All rights reserved. Printed in the USA. January 1997.

The information in this document is subject to change without notice. The statements, configurations, technical data, and recommendations in this document are believed to be accurate and reliable, but are presented without express or implied warranty. Users must take full responsibility for their applications of any products specified in this document. The information in this document is proprietary to Bay Networks, Inc.

The software described in this document is furnished under a license agreement and may only be used in accordance with the terms of that license.

Restricted Rights Legend

Use, duplication, or disclosure by the United States Government is subject to restrictions as set forth in subparagraph (c)(1)(ii) of the Rights in Technical Data and Computer Software clause at DFARS 252.227-7013.

Notice for All Other Executive Agencies

Notwithstanding any other license agreement that may pertain to, or accompany the delivery of, this computer software, the rights of the United States Government regarding its use, reproduction, and disclosure are as set forth in the Commercial Computer Software-Restricted Rights clause at FAR 52.227-19.

Trademarks of Bay Networks, Inc.

Annex, Remote Annex, Annex Manager, Remote Annex 2000, Remote Annex 4000, Remote Annex 6100, Remote Annex 6300, Remote Annex 5390/Async, Remote Annex 5391/CT1, Remote Annex 5393/PRI, BayStack Remote Annex 2000 Server, Quick2Config, Bay Networks, Bay Networks Press, and the Bay Networks logo are trademarks of Bay Networks, Inc.

Third Party Trademarks

Portions subject to copyright by Microcom Systems, Inc. 1993-1997. Used by permission.
All other trademarks and registered trademarks are the property of their respective owners.

Statement of Conditions

In the interest of improving internal design, operational function, and/or reliability, Bay Networks, Inc. reserves the right to make changes to the products described in this document without notice.

Bay Networks, Inc. does not assume any liability that may occur due to the use or application of the product(s) or circuit layout(s) described herein.

In addition, the program and information contained herein are licensed only pursuant to a license agreement that contains restrictions on use and disclosure (that may incorporate by reference certain limitations and notices imposed by third parties).



Revision Level History



Revision	Description
A	Initial release.



Preface

About this Guide	xii
Printing Conventions	xii
Related Documents	xiii

Chapter 1

Introduction

T1 Digital Transmission System	1-1
The Remote Annex 6100	1-3

Chapter 2

Commands and Parameters

T1 Commands	2-1
stats -T	2-2
t1_loopback	2-8
reset	2-10
set t1	2-12
show t1	2-13
T1 Parameters	2-14
alarmsyslog	2-15
bypass	2-16
map	2-17
ring	2-22
sigproto	2-23
switch_type	2-25
t1_info	2-26
tdi_distance	2-27
tdi_framing	2-28
tdi_line_code	2-29
tni_circuit_id	2-30
tni_clock	2-31
tni_esf_fdl	2-32
tni_framing	2-33
tni_line_buildout	2-34
tni_line_code	2-35
tni_ones_density	2-36
T1-Specific Parameters vs. MIB Objects	2-37

Chapter 3

Configuration

Configuring a T1 Connection	3-1
-----------------------------------	-----

Chapter 4

The Internal Modems

Features	4-2
Using the AT Command Set	4-3
Entering AT Commands at Any Speed	4-3

Contents

Key AT Command Factory Defaults	4-4
Hanging Up	4-6
Establishing 11-Bit Data Connections	4-6
V.32bis Cellular Connections Using AT Commands	4-6
Universal Cellular Setup	4-7
MNP 10 V.32bis Quick Connect Cellular Only Setup	4-7
Additional connection speed enhancements	4-8
Modulation Protocols	4-8
Using Multi-Protocol Auto-Answer	4-8
V.34 and V.FC	4-8
V.32 and V.32bis Protocols	4-9
V.23 Protocol	4-10
V.23 1,200 Bps Half-Duplex Operation	4-10
V.22 and V.22bis Protocols	4-11
V.21 Protocol	4-11
Bell 212A Protocol	4-12
Bell 103 Protocol	4-12
Protocol Configuration Command Settings	4-12
Speed and Protocol Connection Matrices	4-15
Error Correction	4-17
MNP Classes	4-17
Other Classes of MNP	4-18
Diagnostics	4-19
Power-Up Diagnostics	4-20
Local Analog Loopback with Self-Test	4-20
Using Commands to Perform a Local Analog Loopback with Self-Test	4-20
Local Analog Loopback	4-21
Using Commands to Perform a Local Analog Loopback	4-21
Remote Digital Loopback with Self-Test	4-22
Remote Digital Loopback	4-23
Using Commands to Perform a Remote Digital Loopback	4-23
Local Digital Loopback	4-24
Using Commands to Perform a Local Digital Loopback	4-24
Respond to Remote Digital Loopback	4-25
Automatically Terminating a Test: Register S18	4-25
Result Codes	4-26
Connection Result Code Tables	4-26
The Command Set	A-1
Entering Commands	A-1
Issuing AT Commands at any Speed	A-2
Commands	A-2
Registers	A-50
Commands to Change or Read Registers	A-50



Figures



Figure 1-1. T1 Wiring Scheme	1-1
Figure 1-2. Typical T1 Transmission System.....	1-2
Figure 1-3. Data Flow in the Receive Direction.....	1-3
Figure 1-4. Data Flow in the Transmit Direction	1-4
Figure 1-5. Remote Access with the Remote Annex 6100.....	1-5
Figure 2-1. DS0 Mapping	2-17
Figure 2-2. Mapping a Modem to an Interface	2-19
Figure 2-3. Mapping the Two Interfaces	2-21



Figures

Table 2-1. T1-Related Commands	2-1
Table 2-2. Arguments for the stats -T Command	2-2
Table 2-3. The stats -T Command Display	2-4
Table 2-4. Keywords for the reset t1 Command	2-10
Table 2-5. Options for Mapping a Modem to an Interface	2-18
Table 2-6. Options for Mapping the Two Interfaces	2-20
Table 2-7. Options for the sigproto command	2-23
Table 2-8. T1- Specific Parameters vs. MIB Objects	2-37
Table 4-1. Key AT Command Factory Defaults	4-4
Table 4-2. Configuring the Modem with %F0 Set	4-13
Table 4-3. Configuring the Modem for V.23 Connections	4-14
Table 4-4. Modem Speed and Protocol Combinations	4-15
Table 4-5. Result Codes	4-26
Table 4-6. Long Form Connect Result Codes	4-27
Table 4-7. Long Form Connect Result Codes	4-28
Table 4-8. Short Form (Numeric) Connect Result Codes	4-30
Table 4-9. ATV0W2 Report Modulation Speed	4-31
Table A-1. The &C and \D Settings	A-15
Table A-2. The \Kn Command	A-23
Table A-3. Modem Connections when %L1 or %L3 is Set	A-24
Table A-4. Modem Connections when %L1 or %L3 is Set	A-25
Table A-5. Modem Connections when %L4 is Set	A-26
Table A-6. Modem Connections when %L0 is Set	A-27
Table A-7. Connection Types Depending on Operating Mode	A-32
Table A-8. Saved Command Settings with S14	A-57
Table A-9. Saved Command Settings with S16	A-58
Table A-10. Saved Command Settings with S21	A-59
Table A-11. Saved Command Settings with S22	A-59
Table A-12. Saved Command Settings with S23	A-60
Table A-13. Saved Command Settings with S27	A-62
Table A-14. T15 Command Settings	A-68
Table A-15. MNP Link Control	A-70
Table A-16. :T23 Settings	A-71
Table A-17. :T26 Settings	A-71



Tables



This guide contains a description of what a network administrator needs to know to configure a Remote Annex 6100 or a Remote Annex 5391/CT1. Additional information can be found in the *Remote Annex 6100 Hardware Installation Guide* and the *Remote Annex 5391/CT1 Hardware Installation Guide*.



About this Guide

This guide includes the following chapters and appendices:

- | | |
|-------------------|--|
| Chapter 1 | Introduction
This chapter contains a T1 overview and a description of the Remote Annex 6100 product. |
| Chapter 2 | T1 Commands and Parameters
This chapter contains a description of all new or enhanced T1 commands and parameters. Syntax and command displays are provided. |
| Chapter 3 | Configuration
This chapter contains a step-by-step description of how to use the T1 commands and parameters to configure a Remote Annex 6100 or a Remote Annex 5391/CT1. |
| Chapter 4 | The Internal Modems
This chapter provides a description of the internal modems and the features that the modems support. |
| Appendix A | The AT Command Set
This appendix contains a list and description of all the AT commands that can be used to control the internal modems. |

Printing Conventions

This manual uses the following printing conventions:

Convention:	Represents:
<code>special type</code>	In examples, special type indicates system output.
special type	Bold special type indicates user input.
<code>Return</code>	In command examples, this notation indicates that pressing <code>Return</code> enters the default value.
bold	Bold indicates commands, pathnames, or filenames that must be entered as displayed.
<i>italics</i>	In the context of commands and command syntax, lowercase italics indicate variables for which the user supplies a value.
[]	In command dialogue, square brackets indicate default values. Pressing <code>Return</code> selects this value. Square brackets appearing in command syntax indicate optional arguments.
{ }	In command syntax, braces indicate that one, and only one, of the enclosed value must be entered.
	In command syntax, this character separates the different options available for a parameter.
	Notes provide important information.
	Warnings inform you about conditions that can have adverse effects on processing.
	Cautions notify you about dangerous conditions.

Related Documents

Each Remote Annex hardware platform ships with the appropriate hardware guide. The remaining documentation is included with the software.



The basic component of a T1 digital transmission system is a DS0 channel (digital signal, level 0). The data stream from 24 DS0 channels makes up a T1 signal.

This chapter contains a basic description of a T1 digital transmission system, and the role the Remote Annex plays in this type of system.

T1 Digital Transmission System

T1 was developed to multiplex 24 analog lines. A T1 digital transmission system takes in 24 analog signals, converts each analog signal to a digital signal, and multiplexes those 24 digital signals onto a 4-wire digital T1 line. What once required 24 2-wire pairs, now requires only two 2-wire pairs (refer to [Figure 1-1](#)).

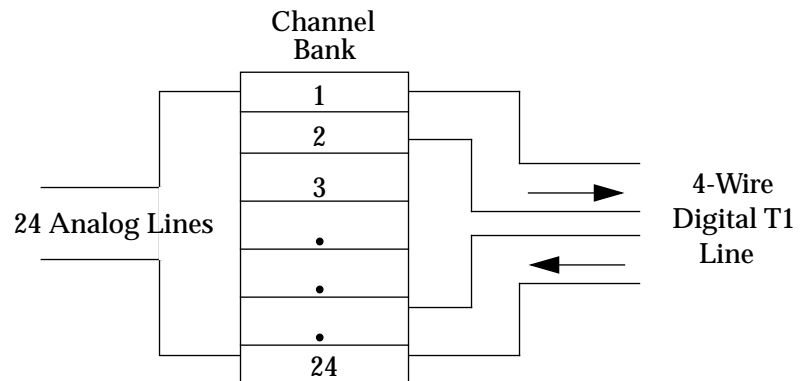

Figure 1-1. T1 Wiring Scheme

A T1 digital transmission system typically consists of two T1 terminal devices such as channel banks connected by a T1 line. The channel bank receives signals from up to 24 analog channels; converts each analog signal to a digital signal; multiplexes the digital signal onto a single 4-wire digital T1 line which carries the T1 signal to the other end of the circuit. At the far end, another channel bank demultiplexes the signal; and converts each of the 24 digital signals back into analog signals (refer to [Figure 1-2](#)).

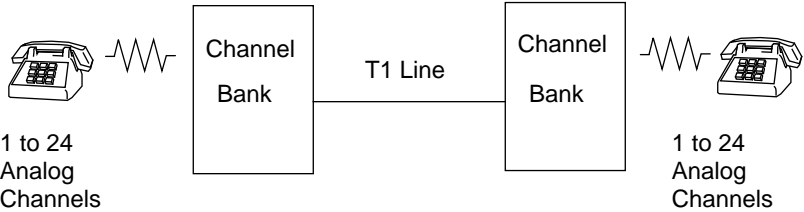

Figure 1-2. Typical T1 Transmission System

All of the multiplexing and demultiplexing is done at a rate of 1.544 Mbps. The individual DS0 channels operate at 64 kbps. All DS0 channels in a T1 channel bank are treated equally.

The Remote Annex 6100

The Remote Annex 6100 is a T1 Remote Access server. The Remote Annex 6100 has a T1 engine that, like a channel bank, receives and transmits data and signaling information from 24 channels simultaneously.

In the receive direction, data is sent to the T1 engine as a digital T1 signal. The T1 engine passes the data stream to the multiplexor where it is demultiplexed and passed to 24 separate DS0 channels. Each DS0 channel has its own coder/decoder (codec) that converts the digital PCM (Pulse Code Modulation) data stream into an analog data stream. The analog data stream is then passed to an internal modem where it is converted to a digital serial data stream and passed to a serial port. [Figure 1-3](#) shows an example of the data flow in the receive direction.

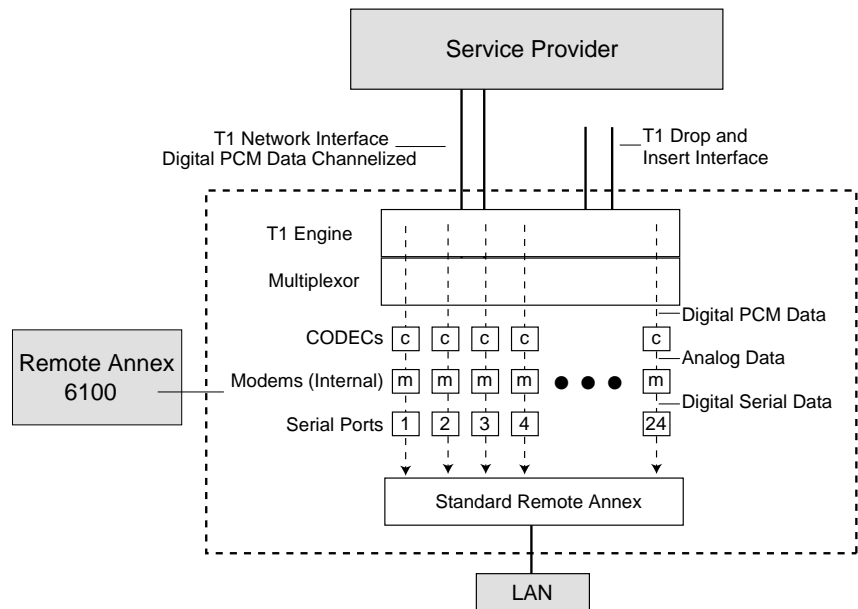

Figure 1-3. Data Flow in the Receive Direction

In the transmit direction, the serial ports pass digital serial data to the modem. The modem converts the data streams to analog data streams and passes them to a codec. The codec converts the analog data stream into digital PCM data streams and passes them to the multiplexor. The multiplexor combines the signals into a single T1 signal and passes it to the T1 engine. The T1 engine sends the signal to the T1 Network Interface which passes it to the T1 line. [Figure 1-4](#) shows an example of the data flow in the transmit direction.

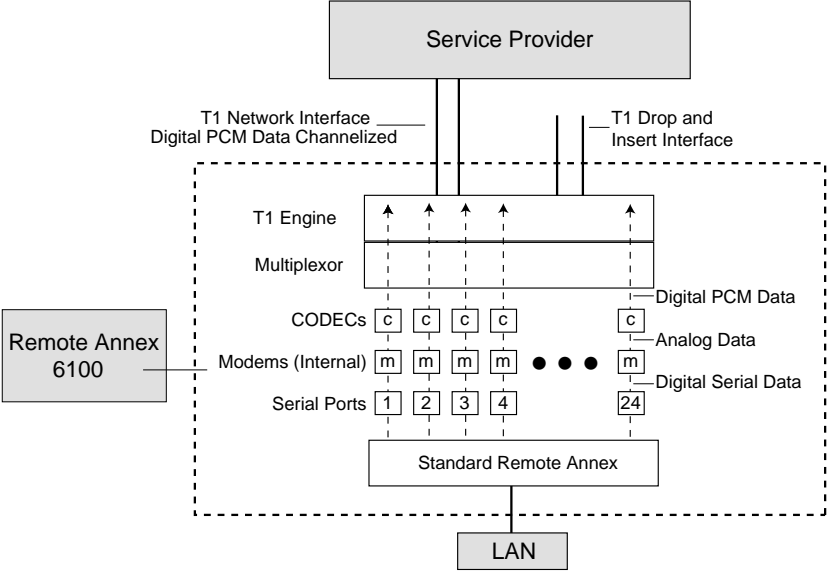

Figure 1-4. Data Flow in the Transmit Direction

The Remote Annex has a maximum of 24 internal modems. The internal modems are high performance, error-correcting V.34 modems. Refer to Chapter 4 *The Internal Modems* for a description of the features that the modems support. The modems are used for dial-in and dial-out access to the LAN. [Figure 1-5](#) illustrates an example of dial-in sessions.

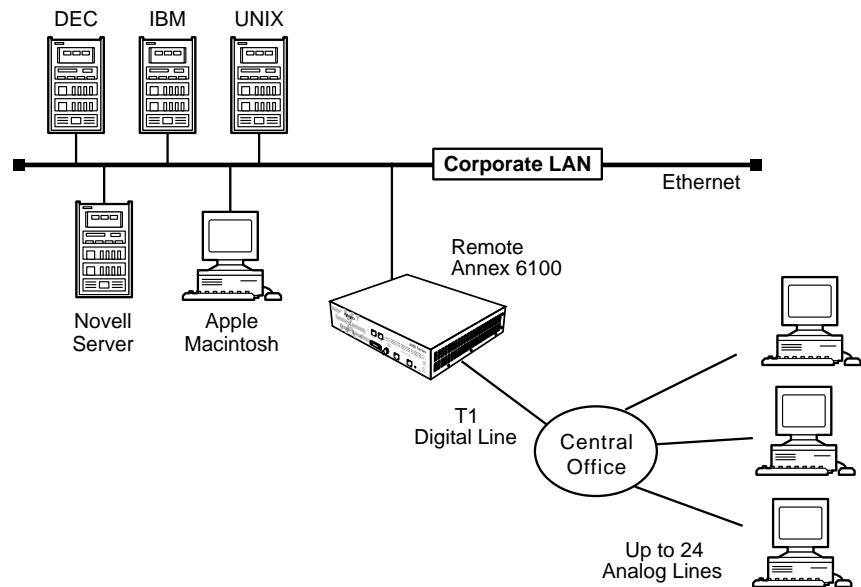

Figure 1-5. Remote Access with the Remote Annex 6100

The Remote Annex comes with software that provides network access to the following networks:

- Novell Netware (IPX)
- UNIX (TCP/IP)
- Macintosh (AppleTalk)

Refer to the *Remoe Annex Administrator's Guide for UNIX* for a description of the supported software features.

In addition to the standard software package, the Remote Annex software distribution includes a number of T1 commands and parameters that are used for configuration and administration (see Chapter 2).

Chapter 2

Commands and Parameters

This chapter contains a description of the T1 software commands and parameters.

The Remote Annex comes with software that supports T1-specific commands and parameters for configuring and administering the device. The following sections describe those commands and parameters.

T1 Commands

The Remote Annex software comes with the following new or enhanced commands:

Table 2-1. T1-Related Commands

Command	Command Type	Description
stats -T	CLI	Displays T1 Network Interface statistics.
t1_loopback	Superuser CLI	Places the T1 engine into loopback mode.
reset	Superuser admin/na/ snmp	Resets the T1 engine, ESF statistics, and internal modems.
set	Superuser admin/na/ snmp	Sets a T1 configuration parameter.
show	admin/na/snmp	Shows a T1 configuration parameter.

These commands are described in more detail in the sections that follow.

stats -T

The **stats -T** command displays T1 network interface statistics for the Annex. [Table 2-2](#) describes the arguments for **stats -T**. The syntax is:

stats -T [**current** | **total** | **all** | *interval_set* | **clear_alarm**]

Table 2-2. Arguments for the **stats -T** Command

Argument	Description
current	Displays T1 statistics information for the current 15-minute interval.
total	Displays a summary of T1 statistics information for the last 24 hours.
all	Displays the T1 statistics for each one of the valid intervals. There are up to 96 intervals (15 minutes per interval) for a 24-hour period.
<i>interval_set</i>	Displays the T1 statistics for the selected intervals only. You can enter a single interval or a range of intervals from 1 to 96. Interval 1 is the most recent interval. For example: stats -T 4-6, 10 displays intervals 4, 5, 6, and 10.
clear_alarm	Clears the alarm condition saved in the history buffer. Once the alarm history buffer is cleared, the next alarm event is captured and stored in the history buffer. Subsequent alarm events will not overwrite the history buffer. This option is available only to the Superuser.

All T1 statistics are captured in 15-minute periods. Information on intervals being captured are kept in “current.” Once the 15-minute interval expires, the information in “current” is transferred to interval #1, and the current statistics are cleared before restarting the statistics capture process. All intervals are aged every 15 minutes. Interval *n* becomes *n*+1, and interval 96 is discarded. The 96 intervals cover a 24-hour period. Interval #1 becomes valid only after the T1 engine has been on-line for at least 15 minutes.

The **stats -T current** command display looks like this:

```
annex# stats -T current
alarm history: [ no blue no red no yellow ], Fri July 28 16:48:37
1995 EDT
Alarms:           no blue           no red           no yellow

engine:offline   no sync           no D&I sync no loss of signal

serial number: 0811
circuit ID:
T1 info:
unit ID: XYLOGICS T1-ENGINE 085234 Rev. A 07/19/95 6343
loopback mode: No loopback           uptime: 69:07:49

                        Current Statistics

number of valid seconds:           469
bursty errored seconds (ESF only):0Controlled slip seconds:0
errored seconds:                   0   Severly errored seconds:0
unavailable seconds:               0

out of frame errors:               0   bipolar violations:      0
CRC errors (ESF only):             0   controlled slips:       0
received net alarms:               0

annex#
```

The information displayed from a **stats -T** command is described in [Table 2-3](#).

Table 2-3. The **stats -T** Command Display

Field	Description
Sync	When Sync is true, the T1 engine is detecting frame synchronization. When Sync is false, the T1 engine has lost frame synchronization and enters the Red Alarm state.
Loss of Signal	When Loss of Signal is true, the T1 engine is not detecting pulses on the T1 network interface receiver. When Loss of Signal is false, the T1 network interface is receiving pulses. The loss of signal condition causes the T1 engine to transmit AIS (all ones unframed) on the T1 network interface.
Blue Alarm	When the Blue Alarm is true, the T1 engine is receiving AIS (all ones unframed) from the network. When the Blue Alarm is false, the T1 engine is not receiving AIS. The Blue Alarm event saved in the history buffer is also displayed.
Red Alarm	When the Red Alarm is true, the T1 engine has detected loss of frame synchronization. During this condition, the T1 interface is sending a Yellow Alarm to the network. When the Red Alarm is false, The T1 engine is in frame synchronization and the sync indication is true. The Red Alarm event saved in the history buffer is also displayed.
Yellow Alarm	When the Yellow Alarm is true, the T1 engine is receiving a Yellow Alarm from the network. When the Yellow Alarm is false, the T1 engine is not receiving a Yellow Alarm from the network. The Yellow Alarm event saved in the history buffer is also displayed.

(continued on next page)

Table 2-3. The **stats -T** Command Display (Continued)

Field	Description
Loopback	<p>The loopback status has the following possible states:</p> <p>None - There is no loopback in progress. The test LED on the front panel is not illuminated.</p> <p>Local - The T1 network interface is in local loopback. The test LED on the front panel is illuminated.</p> <p>Line - The T1 network interface is in line loopback. The test LED on the front panel is illuminated.</p> <p>Payload - This means that the T1 network interface is in payload loopback. The test LED on the front panel is illuminated.</p>
Online	When illuminated, the T1 engine is engaged with the network. Otherwise, the T1 Network Interface and Drop/Insert Interface are isolated from the T1 engine.
Up Time	Amount of time the T1 engine has been up, in hours, minutes, and seconds. The “hours” field is a 16-bit register that can count up to 2700 days (more than 7 years).
Serial Number	The T1 engine’s serial number.
Circuit ID	The T1 engine’s Circuit ID displayed from the t1_circuit_id parameter.
Unit ID	<p>The T1 engine’s Unit ID displayed as:</p> <p>“XYLOGICS T1-ENGINE 085nnn Rev. n mm/dd/yy xxxx”</p> <p>Where:</p> <p>085nnn - This is the firmware number.</p> <p>Rev. n - This is the firmware revision number.</p> <p>mm/dd/yy - This is the firmware release date.</p> <p>xxxx - This is the EPROM check sum.</p>

(continued on next page)

Table 2-3. The **stats -T** Command Display (Continued)

Field	Description
DII Sync	When DII Sync is true, the Drop/Insert Interface is receiving ones pulses and is in frame sync. When DII Sync is false, the Drop/Insert Interface is out of frame sync or not receiving pulses and is sending AIS (all ones unframed).
Interval	The 15-minute interval being displayed. This is an integer from 1 to 96, “current” or “total.”
Number of Valid Seconds	Part of the “current” report which indicates the number of seconds for which the statistics data has been collected.
Number of 15-minute Periods	Part of the “total” report which indicates the number of valid 15-minute periods. This could also be derived from the uptime.
Bursty Errored Seconds	A Bursty Errored Second (BES) is a second with more than one, but less than 320 CRC error events.
Controlled Slip Seconds	A Controlled Slip Second (CSS) is a second with one or more Controlled Slips.
Errored Seconds	An Errored Second is a second with one or more ESF error events; that is, one or more CRC error events or one or more Out of Frames (OOFs).
Severely Errored Seconds	A Severely Errored Second (SES) is a second with 320 or more CRC error events or one or more OOFs.
Unavailable Seconds	Unavailable Seconds (UAS) are a count of 1-second intervals during which service is unavailable.

(continued on next page)

Table 2-3. The **stats -T** Command Display (Continued)

Field	Description
Out of Frame Errors	An Out of Frame (OOF) event begins when any two of four consecutive frame synchronizing bits are received from the network interface. An OOF state ends when reframe occurs.
BiPolar Violations	A BiPolar Violation (BPV) error event for an AMI-coded signal is the occurrence of a pulse of the same polarity as the previous pulse. A BPV error event for a B8ZS--coded signal is the occurrence of a pulse of the same polarity as the previous pulse without being a part of the zero substitution code.
CRC Errors	A CRC error occurs when the CRC field calculated by the customer installation, based on the incoming DS1 signal does not agree with the CRC field contained in the DS1 signal received from the network.
Controlled Slips	A Controlled Slip is the occurrence of a replication or deletion of a DS1 frame by the receiving terminal.
Receive Network Alarm Seconds	The number of seconds with alarm events.

t1_loopback

The Superuser **t1_loopback** command places the T1 engine into loopback mode. None of the loopback conditions persist through a power down or reboot. A major consideration to those using the T1 service must be made before using this command since it will completely disrupt the T1 service. The syntax for the **t1_loopback** command is:

t1_loopback [none | line | payload | local]

The following paragraphs contain a description of the arguments used with the **t1_loopback** command.

None No loopback. This is the default. If the T1_loopback command is initiated with no parameters, then none is assumed. It cancels any user specified loopbacks.

Line Line loopback provides the network a means to test the T1 circuit for single ended fault isolation. The line loopback regenerates the DS1 signal and does not correct bipolar violations.

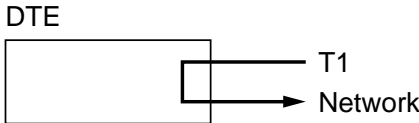

Payload Payload loopback is used to provide a loopback toward the network. The data portion of the DS0s is looped back.

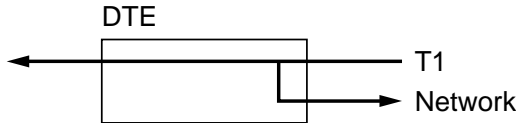

Local

Local loopback will loopback the data from the customer side of both the T1 Network Interface and the T1 Drop/Insert Interface.



Network direction loopbacks in most cases can be initiated by the service provider. The front panel Test indicator illuminates when the T1 is in loopback.

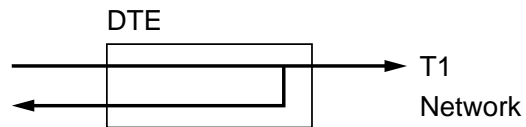

reset



The **reset** command (available from **na** or **admin**) requires Superuser privileges. A **reset** terminates any active connections.

The **reset t1** command resets the T1 engine and the T1 statistics information. This command is used to change the T1 engine's parameter configuration. The T1 *soft*, *hard*, and *esf* keywords are described in [Table 2-4](#). The syntax is:

reset t1 [*soft* | *hard* | *esf*]

Table 2-4. Keywords for the reset t1 Command

Keyword	Definition
soft	This setting reconfigures the software parameters and will only disrupt the service on the DS0 channels that are changed.
hard	This setting resets the T1 engine causing the T1 Drop/Insert interface and modem sessions to terminate.  If modem sessions and/or equipment are attached to the Drop and Insert Interface, their service will be interrupted for a short period of time (usually a few seconds).
esf	This setting resets all the statistics in the T1 engine.

The **reset int_modem** command resets the specified T1 *modem_set*. There is no physical reset button. A modem reset forces the port to be reset. In addition, if the signal protocol is set to **wink start** or **immediate start**, a special AT command is sent to the modem to select the dialtone detection mechanism.

The *modem_set* parameter specifies the individual modem numbers, separated by commas, or a range of numbers separated by a hyphen. The valid modem number range is 1 to 24, inclusive.

The syntax is:

reset int_modem <*modem_set*>

set t1



The **set t1** command (available from **na** or **admin**) requires Superuser privileges.

The **set t1** command modifies Remote Annex configuration parameters.

The syntax is:

set t1 *t1_parameters*

Refer to [T1 Parameters](#) on page 2-14 for a list and description of the keywords that can be used with this command.

show t1

The **show t1** command (available from **na** or **admin**) displays current T1 configuration parameters.

The syntax is:

show t1 *t1_parameter*

Refer to [T1 Parameters](#) on page 2-14 for a list and description of the keywords that can be used with this command.

T1 Parameters

The Remote Annex software comes with the following new T1 parameters:

- *alarmsyslog*
- *bypass*
- *map*
- *ring*
- *sigproto*
- *switch_type*
- *t1_info*
- *tdi_distance*
- *tdi_framing*
- *tdi_line_code*
- *tmi_circuit_id*
- *tmi_clock*
- *tmi_esf_fdl*
- *tmi_framing*
- *tmi_line_buildout*
- *tmi_line_code*
- *tmi_ones_density*

The following paragraphs contain a description of the T1 parameters.

alarmsyslog

This T1 parameter enables or disables the T1 alarm event syslogs. A **Y** enables alarm syslogs, an **N** disables it. The default is **Y**.

The command display looks like this:

```
admin: set t1 alarmsyslog no
admin: show t1 alarmsyslog
alarmsyslog: no
admin:
```

bypass

This T1 parameter is used to remove the T1 engine from the network. When **bypass** is set to **Y**, the T1 engine is off-line and the T1 Network Interface (T1NI) and the T1 Drop and Insert Interface (T1DII) are physically isolated from the T1 engine. When **bypass** is set to **Y**, the T1 engine has no effect on the T1 circuit. When **bypass** is set to **N**, the T1 engine is attached to both the T1NI and the T1DII. The default is **Y**.

The command display looks like this:

```
admin: set t1 bypass yes
admin: show t1 bypass
bypass: yes
admin:
```

map

This T1 parameter controls the mapping of the modems to the T1 Drop and Insert Interface (T1DII) and the T1 Network Interface (T1NI) DS0 channels. The modems can be mapped to any unoccupied slot on either interface. The interfaces can be mapped to each other on channels that are not occupied by modems. [Figure 2-1](#) shows an example of interface and modem mapping.

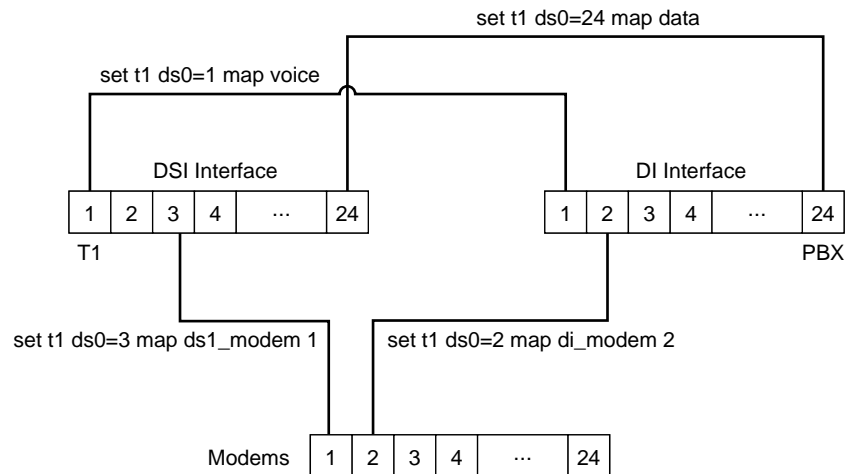

Figure 2-1. DS0 Mapping

The map command is used in two ways:

- Mapping a modem to an interface.
- Mapping the two interfaces.

Mapping a Modem to an Interface

The syntax for mapping a modem to an interface is as follows:

```
set t1 ds0=<channel_number> map <map_val> <modem_number>
```

Table 2-5. Options for Mapping a Modem to an Interface

Option	Description
<i>channel number</i>	A T1 Network Interface or Drop/Insert Interface channel number from 1 to 24.
<i>map_val</i>	The <i>map_val</i> option defines the interface as: ds1_modem for the T1 Network Interface. di_modem for the Drop/Insert Interface.
<i>modem_number</i>	This option must be specified. The <i>modem_number</i> value is a number from 1 to 24.

[Figure 2-2](#) illustrates this mapping.

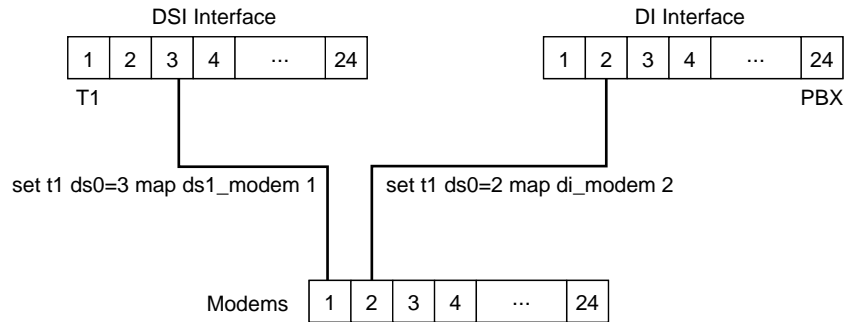

Figure 2-2. Mapping a Modem to an Interface

The command display for the previous example looks like this:

```
admin: show t1 ds0=2,3 map
ds0:2      di          modem 2
ds0:3      ds1         modem 1
admin:
```

Mapping the Two Interfaces

The syntax for mapping the two interfaces is as follows:

```
set t1 ds0=<channel_set> map <map_val>
```

Table 2-6. Options for Mapping the Two Interfaces

Option	Description
<i>channel_set</i>	A set of DS0 channels that includes a range from 1 to 24 and hyphenated ranges.
<i>map_val</i>	The <i>map_val</i> option can be: <ul style="list-style-type: none">• unused• voice - maps the DS0 channel to the DI interface (voice).• data - maps the DS0 channel to the DI interface (data).

Setting a **ds0** to **unused** makes it look busy to remote callers. This setting is useful when a modem malfunctions and needs to be replaced.

[Figure 2-3](#) illustrates this mapping.

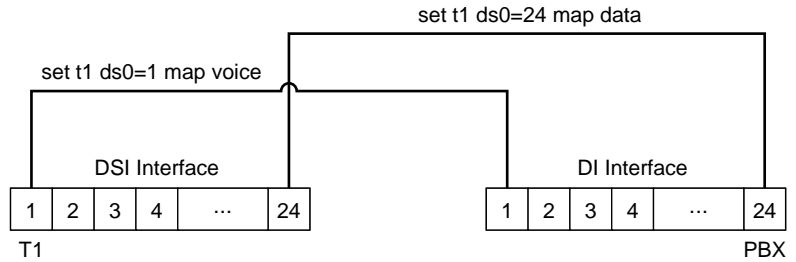

Figure 2-3. Mapping the Two Interfaces

The command display looks like this:

```
admin: show t1 ds0=1,4,24 map
ds0:1    voice
ds0:4    unused
ds0:24   data
admin:
```

ring

This T1 parameter is used to provide the audible ring to the central office for incoming calls. The default is Y, and the audible ring is sent to the central office. This parameter is used with **wink_start** and **immediate_start** protocols only. The syntax for this command is:

```
set t1 ds0=<channel_set> ring [yes | no]
```

The *channel_set* option represents a set of DS0 channels from 1 to 24.

The command display looks like this:

```
admin: show t1 ring
ds0:      1      yes
ds0:      2      no
.
.
.
ds0:      24     yes
admin:
```

sigproto

This T1 parameter is used to specify the inbound and outbound signaling protocols supported by each T1 channel (DS0). Each channel supports an inbound protocol and an outbound protocol. Both protocols must be specified even if they are the same. If the protocol pair is invalid, it is rejected with an error message. For inbound-only channels, the outbound protocol must be set to none. For outbound-only channels the inbound protocol must be set to none. The syntax for this command is:

```
set t1 ds0=<channel_set> sigproto <proto_in> <proto_out>
```

Table 2-7. Options for the **sigproto** command

Option	Description
<i>channel_set</i>	A set of DS0 channels that includes a range from 1 to 24 and hyphenated ranges.
<i>proto_in</i>	The <i>proto_in</i> option defines an inbound signaling protocol. The signaling protocols are:
	<ul style="list-style-type: none"> • loop_start - Bidirectional (default)
	<ul style="list-style-type: none"> • ground_start - Bidirectional
	<ul style="list-style-type: none"> • wink_start - Inbound, outbound, or bidirectional
	<ul style="list-style-type: none"> • immediate_start - Inbound, outbound
	<ul style="list-style-type: none"> • None
<i>proto_out</i>	The <i>proto_out</i> option defines an outbound signaling protocol. The protocols are described above.

The command display looks like this:

```
admin: set t1 ds0=3,8 sigproto immediate_start none
admin: show t1 sigproto
ds0:          1          in: loop_start
out: loop_start
ds0:          2          in: wink_start
out: wink_start
ds0:          3          in: immediate_start
out: none
ds0:          8          in: immediate_start
out: none
.
```

switch_type

This parameter can be configured to support standard Channelized T1, Hong Kong Channelized T1, and a 1AESS switch running Channelized T1.

Standard Channelized T1 is the default configuration for this parameter.

When configured for Hong Kong, it reconfigures the modem's output levels (low frequency component to -10dBm0 and high frequency component to -6dBm0) and will reprogram the ring cadence to 300ms on, 400ms off, 300ms on, and 3s off.

When configured for 1AESS switch, it sends 00 instead of 11 through the AB bits to signal busy when configured for Ground Start.

The following command display shows how to configure the switch_type parameter for Hong Kong Channelized T1:

```
admin: set t1 switch_type hk
admin:
```



After the **set T1 switch_type hk** command is issued, you must change the type_of_modem field to BAYT1_HK_288 in the modem section of the Annex configuration file. You must also set the type_of_modem port parameter to BAYT1_HK_288. See the *Remote Annex Administrator's Guide for UNIX* for more information.

t1_info

This T1 parameter stores installation information from the service provider, such as a telephone number to call should the network go down. This parameter is limited to a 120-byte string of printable ASCII characters. The command display looks like this:

```
admin: set t1 t1_info "Example: If the network goes down, call x555"  
admin: show t1 t1_info  
t1_info: "Example: If the network goes down, call x555"  
admin:
```

tdi_distance

This T1 parameter defines the distance, in feet, of the cable that runs from the T1DII to the Private Branch Exchange (PBX) or other equipment. The parameter setting is an integer from **0** to **655**. The default setting is **0**. The command display looks like this:

```
admin: set t1 tdi_distance 200
admin: show t1 tdi_distance
tdi_distance: 200
admin:
```

tdi_framing

This T1 parameter controls which super frame format is used on the T1 Drop/Insert Interface. The parameter settings are **d4** (super frame) and **esf** (extended super frame). The default setting is **esf**. The value for **tdi_framing** may or may not be the same as **tni_framing**. The command display looks like this:

```
admin: set t1 tdi_framing esf
admin: show t1 tdi_framing
tdi_framing: esf
admin:
```

tdi_line_code

This T1 parameter selects the line code to be used on the T1 Drop/Insert Interface (T1DII). The device connected to the T1DII determines which line code to use. The parameter settings are **ami** and **b8zs**. The default setting is **b8zs**. The command display looks like this:

```
admin: set t1 tdi_line_code b8zs
admin: show t1 tdi_line_code
tdi_line_code:b8zs
admin:
```

tni_circuit_id

This T1 parameter stores the T1 Circuit Identifier String. The T1 Circuit Identifier String comes from the service provider and is used for customer service calls. The parameter setting is a string of up to 120 characters. The default setting is the null string. The command display looks like this:

```
admin: set t1 tni_circuit_id "this is a sample circuit ID"
admin: show t1 tni_circuit_id
tni_circuit_id: "this is a sample circuit ID"
admin:
```

t1_clock

This T1 parameter sets the clock for the T1 Network Interface. Parameter settings include **loop** (service provider), **local** (Annex), **external** (T1 Drop/Insert Interface). The default setting is **loop**. The command display looks like this:

```
admin: set t1 tni_clock loop
admin: show t1 tni_clock
tni_clock: loop
admin:
```

t1_esf_fdl

This T1 parameter sets the T1 Facilities Data Link (FDL) format. The FDL format is used in conjunction with the ESF format and is determined by the service provider. The parameter settings include **ANSI** (ANSI T1.403) and **AT&T** (AT&T TR54016) standard formats. The command display looks like this:

```
admin: set t1 t1_esf_fdl att
admin: show t1 t1_esf_fdl
t1_esf_fdl: att
admin:
```

tni_framing

This T1 parameter controls which super frame format is used on the T1 Network Interface. Parameter settings include **d4** (super frame) and **esf** (extended super frame). The default setting is **esf**. The value for **tni_framing** may or may not be the same as **tdi_framing**. The command display looks like this:

```
admin: set t1 tni_framing esf
admin: show t1 tni_framing
tni_framing: esf
admin:
```

t1_line_buildout

This T1 parameter sets the Line Build-Out (LBO) value. The Channel Service Unit (CSU) portion of the T1 Network Interface requires the administrator to configure a LBO value. The service provider will supply a value measured in decibels (dB) based on the amount of cable loss from the service provider's location to the Annex. Parameter settings include **0**, **7.5**, **15**, and **22.5**. The default is **0**. The command display looks like this:

```
admin: set t1 t1_line_buildout 7.5
admin: show t1 t1_line_buildout
t1_line_buildout: 7.5
admin:
```

tni_line_code

This T1 parameter selects the line code for the T1 Network Interface. The service provider determines the line code setting. Parameter settings include **ami** and **b8Zs**. The default setting is **b8zs**. The command display looks like this:

```
admin: set t1 tni_line_code b8zs
admin: show t1 tni_line_code
tni_line_code: b8zs
admin:
```

t1_ones_density

This T1 parameter is used to defeat the Annex's ones density monitor. The Annex T1 engine has a built in ones density monitor that will provide the network with the correct number of one pulses. The ones density monitor does the following:

1. **The monitor does not allow the Annex to transmit more than 15 consecutive zeros.**
2. **The monitor ensures that the Annex has at least N ones in every time window of $8X(N+1)$ bits, where $N=1$ to 23.**

This parameter has an **on** and an **off** setting. This parameter should be set to **on** when using AMI coding. The default is **off**. The command display looks like this:

```
admin: set t1 tni_ones_density off
admin: show t1 tni_ones_density
tni_ones_density: off
admin:
```

T1-Specific Parameters vs. MIB Objects

[Table 2-8](#) lists the T1-specific parameters and their corresponding MIB object names. Refer to the *Annex Network Administrator's Guide* for a description of the Simple Network Management Protocol (SNMP).

The following string precedes the MIB object names:
 “.iso.org.dod.internet.private.enterprises.xylogics.annex.”.

Table 2-8. T1- Specific Parameters vs. MIB Objects

T1 Parameter	MIB Object Name
alarmsyslog	anxt1AlarmSyslog
bypass	anxt1EngineBypass
map	anxt1ChanMap
ring	anxt1ChanRing
sigproto	anxt1ChanSigProto
t1_info	anxt1Info
tdi_distance	anxt1DiiDistance
tdi_framing	anxt1DiiFraming
tdi_line_code	anxt1DiiLineCode
t1_line_buildout	anxt1Ds1LineBuildout
t1_ones_density	anxt1Ds1OnesDensity



• Chapter 2 *Commands and Parameters*



This chapter contains a description of the steps you need to take to set up your Remote Annex and T1 connection.

Refer to the *Remote Annex 6100 Hardware Installation Guide* or the *Remote Annex 5391/CT1 Hardware Installation Guide* for information about installing the hardware. Refer to the *Remote Annex Administrator's Guide for UNIX* for configuration information.

Configuring a T1 Connection

The following information will help you configure your T1 connection and bring your Remote Annex on-line. Proceed as follows:

1. Obtain the following information:

- IP address
- Subnet mask
- IP address of load host
- IP address of dump host
- Broadcast address
- T1 framing
- T1 line code
- T1 signaling



Your System Administrator and Service Provider should have the information described in Step 1.

2. **Be sure that a 9600-baud terminal is attached to the console port (Remote Annex 6100) or the service port (Remote Annex 5391/CT1).**
3. **Power up the Remote Annex. Press the Setup button (Remote Annex 6100 only).**

Make sure the Setup light is On (Remote Annex 6100 only). The power-up diagnostics will run and the Monitor prompt will display on the console or the service port terminal when the diagnostics are finished.

4. **Enter the `addr` command at the ROM monitor prompt and specify IP addresses as necessary.**
5. **Enter the `image` command at the ROM monitor prompt and specify `oper.46.enet` as the image name.**
6. **Enter the `sequence` command and specify the type of boot sequence. Examples are:**
 - `self`
 - `net, self`
 - `self, net`
7. **Enter the `boot` command to boot the Remote Annex.**

Wait for the device to complete the boot process.

8. Use the **na** command from a host on the network, the **admin** command from a virtual cli connection, or **snmp** to set the following T1 parameters (see Chapter 2):
 - **tni_framing**
 - **tni_line_code**
 - **sigproto**
 - **bypass to n**



Your service provider can give you information on the appropriate parameter settings.

9. **Set other T1 parameters.**

There are other T1 parameters such as **map** and **ring** that may need to be set depending upon your configuration (see Chapter 2).
10. **Reboot the Remote Annex.**
11. **Enter the stats -T current command for a description of the T1 Network Interface statistics.**



• Chapter 3 Configuration





Chapter 4

The Internal Modems

The internal modems support the enhanced V.34 standard (up to 33,600 bps), are fully compatible with V.FC (V.fast Class) modems and offer support for cellular operations.

Your modem automatically attempts to connect at 33,600 bps, so you don't need to change any of its commands or settings. Due to limitations imposed by poor phone line quality or the other modem's capability, you may not always connect at 33,600 bps. If the modem you are dialing does not support the 33,600 bps standard, you will always connect at the highest speed that is possible. By default, your modem will start a negotiation at V.34 and then try V.FC, V.32bis, and V.32 (in that order), permitting the highest speed connections with other modems.

The enhanced V.34 standard maintains the improvements introduced by V.34, such as the V.8 handshake between V.34 modems that minimizes the time it takes you to make a connection. If line conditions require fallback or permit fall-forward, your modem can perform either, when you are connected to another V.34 modem. If the other modem does not have the V.34 capability, your modem uses earlier negotiation protocols.

Under optimum conditions, the modems reach a maximum serial-port speed of 115,200 bps. They support V.42bis data compression, and use Hayes Smartmodem AT and V.25bis command sets, with enhancements for maximum flexibility. The modems achieve error-free performance through the Microcom Networking Protocol (MNP) and V.42 error-correction protocol standards. They offer MNP Class 10 with Adverse Channel Enhancements (ACE). MNP 10 includes:

- Multiple connection attempts during auto-reliable link negotiation.
- Negotiated speed upshifts.
- Aggressive adaptive packet assembly.
- Dynamic Transmit Level Adjustment.

Features

- ITU-T standards: V.21, V.22, V.22bis, V.23, V.32, V.32bis, and V.34.
- Compatibility with Rockwell International's V.FC protocol.
- Serial-port speeds of up to 115,200 bps.
- Bell 212A and Bell 103 protocol standards.
- V.42 error correction, including LAPM and MNP2 through 4.
- V.42bis compression as well as MNP5 Data Compression.
- MNP Class 10 Adverse Channel Enhancements (ACE).
- 14,400 bps, Class 1, Group III fax send and receive operation through fax and data communications software; Windows version included.
- Enhanced operation in cellular environments.
- V25bis asynchronous operation.
- Multi-protocol auto-answering to answer incoming calls automatically using various modulation protocols.
- Trellis coded modulation for forward error correction.
- Near- and far-end echo cancellation.
- Automatic power-up diagnostics.
- Asynchronous 11-bit character support.

Using the AT Command Set

Each command line must begin with the characters **AT** (the **AT**tention code). Both characters of the attention code must be in either upper case or lower case, but you may type the commands in any combination.

Type commands after the **OK** response. The modem ignores spaces between characters. If you make a mistake, press the backspace key (**Ctrl**-**H**) and type the correct character. To make a command take effect, press **Enter**.

Entering AT Commands at Any Speed

You can enter an AT command at any supported serial-port speed up to 115,200 bps. Your modem automatically adjusts to the connection and command speeds (autobauds) up to 19,200 bps. After you enter an AT at any speed up to 19,200 bps, you can enter other commands at a new serial-port speed at any time. If you enter a command at 38,400, 57,600 or 115,200 bps, **the serial port locks** at that speed.

To unlock the serial-port speed and change to another speed:

- type **AT\$Bn** (*n is any supported serial-port speed*), **OR**
- type **AT%U** **Enter** to unlock the serial-port speed, then enter an AT at the new speed.

Now enter an **AT** at the new speed.



The serial-port speed defaults to 115,200 bps.

Key AT Command Factory Defaults

Table 4-1. Key AT Command Factory Defaults

AT	Title	Default
\$Bn	Serial-Port Bps Rate	115,200
%Bn	Modem-Port Bps Rate	28800
%Cn	Compression Control	3 (MNP 5 & V.42bis)
&Cn	Serial-Port DCD Control	1 (On after connect message)
D	Dial	T (Tone dial)
&Dn	DTR Control	2
En	Command Echo	1 (echo to local DTE)
&F	Restore Factory Defaults	none
H	Hang Up	none
*Hn	Link Negotiation Speed	0 (at highest speed)
\Jn	Bps Rate Adjust	0 (disabled)
%Ln	Speed Matching	1 (enabled)
)Mn	Cellular Power Level Adjustment	0 (For central site modems)
@Mn	Select Cellular Transmit Level	0 (-26 dBm)
\Nn	Operating Mode	3 (auto-reliable)
On	Enter Connect State and Retrain	none
Qn	Quiet	0 (result code output)
\Qn	Serial-Port Flow Control	3 (bi-directional hardware)
%Rn	Read All Registers	none

(continued on next page)

Table 4-1. Key AT Command Factory Defaults (continued)

AT	Title	Default
<i>Sn?</i>	Read Configuration Register	none
<i>\S</i>	Read On-line Status	none
<i>T</i>	Tone Dial	none
<i>:Tn?</i>	Read Configuration Register	none
<i>Vn</i>	Result Code Form	1 (long form)
<i>\Vn</i>	Error Correction Result Code Form	2 (long form)
<i>%V</i>	Display Modem Firmware Version	none
<i>&Wn</i>	Store Current Configuration	0
<i>*Wn</i>	Store Complete Configuration	0

You are ready to establish a connection as either a dialing modem or an auto-answer modem. For tone dialing, type:

ATDT <telephone number>

The modem automatically answers calls on the first ring if DTR is present.

Hanging Up

To hang up, use **one** of these methods:

- Pause 1 second. Then type +++ to enter command state. Type **ATH** to hang up *OR*
- Lower DTR with your communications program when &D2 or &D3 is set.

See Appendix A for detailed information about any of the commands mentioned above.

Establishing 11-Bit Data Connections

By default, your modem port passes 10-bit characters during MNP or LAPM connections.

In a normal or direct connection, those bit and parity settings on the originating and remote modems must match for data to transfer accurately. The serial-port parity determines the number of data bits set during a direct connection.

The -E command determines the characters handled on the modem port during a normal connection—unless the modem falls back from a reliable connection (either \N3 or \N5 is set) to a normal connection. In this case, the remote modem port must be set for a data length of 10 bits.

V.32bis Cellular Connections Using AT Commands

The internal V.34 modems may be set up in different ways to operate over a cellular telephone network. The following are typical setups that might be used.



Your modem supports cellular operation from 1200 to 14,400 bps. MNP Class 10 is **not active** for connections below 1200 bps.

Universal Cellular Setup

Land-side modem - AT&F (factory defaults)

This allows the land side to make data connections with land based and cellular based modems without reducing maximum connection speeds. Connections over most land lines can reach 14,400 bps modem speeds between V.32bis modems, and 33,600 bps between V.34 modems. MNP 10 cellular connections occur at the highest speed the modems determine they can support for each cellular connection. If the land-side modem will only make cellular connections, we recommend setting \N2.

MNP 10 V.32bis Quick Connect Cellular Only Setup

Land-side modem - AT&FN2)M1

This forces MNP connections to all modems and MNP 10 cellular connections to all MNP 10 modems.

Additional connection speed enhancements

In addition, registers `:T17` and `:T26` can shorten connect times. We suggest changing these registers only after making some cellular connections with these registers set to defaults. Using them may limit the modem's ability to connect over noisy lines.

Modulation Protocols

Using Multi-Protocol Auto-Answer

The multi-protocol auto-answer feature allows auto-answer of incoming calls from modems using any of the following protocols: V.34, V.FC, V.32bis, V.32, V.22bis, V.22 (1200 bps only), V.21, V.23 half-duplex, Bell 212A, and Bell 103.



To enable this feature for V.23 half-duplex connections, set `:T2` to a value greater than 0. We recommend setting `:T2=20` when falling back to a V.23 half-duplex connection.

V.34 and V.FC

Basically, V.34 is the new ITU-T standard that formalizes the temporary V.FC (V.fast Class) protocol. It has all the features of our V.FC modems, plus the additional commands described in Appendix A. You can enjoy the same 33,600 bps connect speeds, high data integrity, and throughputs of 115,200 bps.

One obvious improvement is “handshaking” between V.34 modems. Connection negotiation will take about 5 seconds instead of up to 15 seconds and will use a few new tones. V.34 includes the new V.8 handshake standard, and adds line probing and fast negotiation between two modems that support it. If the other modem does not include V.8, your modem will proceed with the previous negotiation methods. Expect these faster negotiations as V.34 modems become common.

You should also see better adaptations to phone lines. In V.34 connections, our modems stay in that modulation from 2,400 through 33,600 bps. The V.FC range is 14,000 through 28,800 bps. If line conditions require fallback or permit fall-forward, two V.34 modems can perform either easily.

Finally, while not all V.34 modems support V.FC connections, ours do. That means you can expect continued high-speed connections to over 1 million V.FC modems from over 120 vendors. By default, your modem will start a negotiation at V.34 and if it can’t get one, connect at V.FC, V.32bis and V.32 in that order — permitting the highest speed connections with other modems.

V.32 and V.32bis Protocols

The ITU-T V.32 protocol is for full-duplex data transfer over general switched telephone networks at 9,600 and 4,800 bps. V.32 employs echo cancellation and trellis coded modulation.

The ITU-T V.32bis specification enhances V.32 by adding 14,400, 12,000, and 7,200 bps speeds and special rate sequences to shorten speed upshifting and downshifting.

V.23 Protocol

The modem supports one V.23 mode -- main channel half duplex at 1200 bps.



When you configure your modem for V.23 operation by setting the `%Fn` command to a value other than 0, this disables other modulation protocols.

The features described in this manual apply to V.23 operation except that the modem does not support:

- V.54 digital and analog loopback.
- MNP and LAPM connections.

V.23 1,200 Bps Half-Duplex Operation

V.23 half-duplex operation is available only for direct and normal connections.

For V.23 half-duplex connections set **%F3** on both modems.



When the modem establishes a V.23 half-duplex connection it displays **CONNECT V.23 HDX**.

When the originate modem is set to **normal mode**, you must send a few characters to the answer modem before the originate modem can fall back to a V.23 half-duplex connection.

V.22 and V.22bis Protocols

V.22 protocol is used for 1200 bps and 600 bps full-duplex connections. The version of V.22 your modem supports is Alternative B.

V.22bis protocol enhances V.22 by adding 2400 bps full-duplex connections.



For V.22 at 600 bps, *both modems* must be set to 600 bps.

V.21 Protocol

V.21 protocol is used for 300 bps full-duplex connections. The features described in this manual apply to V.21 operation except that your modem does not support:

- V.54 digital and analog loopback.
- LAPM connections.



When your modem establishes a V.21 connection, it displays **CONNECT V.21/REL - MNP**. With a normal or direct V.21 connection, the message is **CONNECT**.

Bell 212A Protocol

Bell 212A protocol is for 1200 bps full-duplex connections.

Bell 103 Protocol

Bell 103 protocol is for 300 bps full-duplex connections. The features described in this guide apply to Bell 103 operation except that your modem does not support:

- Digital (loop 1A) and analog (V.54 loop 3) loopback.
- LAPM connections.



When your modem establishes a reliable Bell 103 connection, it displays **CONNECT 103/REL - MNP**. For a normal or direct Bell 103 connection, the message is **CONNECT**.

Protocol Configuration Command Settings

When you send an **AT** string to the modem, it adjusts modem-port speed automatically to match the **AT** speed. Use **%G1** to disable this feature. With **%G1** set, you can change the modem speed with **%Bn** (where *n* is the new modem speed) and **%Fn**.

This section lists settings to configure the modem for each mode and protocol. Modem connection speeds are in parentheses.

Table 4-2. Configuring the Modem with %F0 Set

Protocol	Issue %G0:	Issue %G1:
V.21 (75-300 bps)	B0 at 300 bps	B0%B300
Bell 103 (75-300 bps)	B1 at 300 bps	B1%B300
V.22 (600 bps)	at 600 bps	%B600
V.22 (1200 bps)	B0 at 1200 bps	B0%B1200
Bell 212A (1200 bps)	B1 at 1200 bps	B1%B1200
V.34/V.22bis (2400 bps)	at 2400 bps	%B2400
V.34/V.32bis/V.32 (4800 bps)	at 4800 bps	%B4800
V.34/V.32bis (7200 bps)	at 7200 bps	%B7200
V.34/V.32bis/V.32 (9600 bps)	at 9600 bps	%B9600
V.34/V.32bis (12000 bps)	at 12000 bps	%B12000
V.34/V.32bis (14400 bps)	at 14400 bps	%B14400
V.34/V.FC (14400 bps)	at 14400 bps	%BV14400
V.34/V.FC (16800 bps)	at 16800 bps	%B16800
V.34/V.FC (19200 bps)	at 19200 bps	%B19200
V.34/V.FC (21600 bps)	at 21600 bps	%B21600
V.34/V.FC (24000 bps)	at 24000 bps	%B24000
V.34/V.FC (26400 bps)	at 26400 bps	%B26400
V.34/V.FC (28800 bps)	at 28800 bps	%B28800
V.34 (31200 bps)	at 31200 bps	%B31200
V.34 (33600 bps)	at 33600 bps	%B33600



For the highest possible throughput available, set the modem-port speed by typing `AT%G1%Bn` (where *n* equals the desired speed).

Table 4-3. Configuring the Modem for V.23 Connections

When %F1, %F2, or %F3 is set for V.23 connections:	
Protocol	Command
V.23 (1200 bps half duplex)	%F3

Speed and Protocol Connection Matrices

The following tables show the possible speed and protocol combinations for modem connections. They also illustrate the action of an answer modem set to use multi-mode answering.

Table 4-4. Modem Speed and Protocol Combinations

Mode Setting on Originating Modem	Mode Setting on Answer Modem					
	V.22[b]	V.22[a]	V.22bis	V.32	V.32bis	V.34/V.FC
V.34 (31200-33600)	—	V.22[a]	V.22bis	V.32	V.32bis	V.34/V.FC
V.34/V.FC (14400-28800)	—		V.22bis	V.32	V.32bis	V.34/V.FC
V.34/V.32bis (4800-14400)	—	V.22[a]	V.22bis	V.32	V.32bis	V.34/V.32bis
V.34/V.32 (4800-9600)	—	V.22[a]	V.22bis	V.32	V.32	V.34/V.32
V.34/V.22bis (2400)	—	V.22[a]	V.22bis	V.22bis	V.22bis	V.34/V.22bis
V.22[a] (1200)	—	V.22[a]	V.22[a]	V.22[a]	V.22[a]	V.22[a]
V.22[b] (600)	V.22[b]	—	—	—	—	—
V.23[c] (half-duplex)	—	V.23[c]	V.23[c]	V.23[c]	V.23[c]	V.23[c]
V.21(75-300)	—	V.21	V.21	V.21	V.21	V.21
Bell212A (1200)	—	V.22[a]	V.22[a]	V.22[a]	V.22[a]	V.22[a]
Bell103 (300)	—	Bell103	Bell103	Bell103	Bell103	Bell 103

Table 4-4. Modem Speed and Protocol Combinations (Continued)

Mode Setting on Originating Modem	Mode Setting on Answer Modem			
	Bell103	Bell212A	V.21	V.23[c]
V.34 (31200-33600)	Bell103	Bell212A	—	—
V.34/V.FC (2400-28800)	Bell103	Bell212A	—	—
V.34/V.32bis (4800-14400)	Bell103	Bell212A	—	—
V.34/V.32 (4800-9600)	Bell103	Bell212A	—	—
V.34/V.22bis (2400)	Bell103	Bell212A	—	—
V.22[a] (1200)	Bell103	Bell212A	—	—
V.22[b] (600)	—	—	—	—
V.23[c] (half-duplex)	—	—	—	V.23[c]
V.21(75-300)	—	V.21	V.21	—
Bell212A (1200)	Bell212A	Bell212A	—	—
Bell103 (300)	Bell103	Bell103	—	—



For operations at V.22 600 bps, both modems must be set to 600.

Error Correction

MNP Classes

The modem provides MNP Class 10 and supports MNP Class 5 data compression. It is compatible with all MNP products. Its enhanced MNP service is completely transparent to the user.

Class 10: Adverse Channel Enhancements (ACE) optimizes performance under poor line conditions. Class 10 continues to provide compatibility with non-MNP modems. It improves initial connection success rate by making multiple negotiation attempts when configured for auto-reliable mode. It uses Dynamic Transmit Level Adjustment to calculate optimal transmit levels automatically to compensate for cellular phone signal distortion. It lets the user configure the modem to negotiate the link at a low-speed modulation, then upshift to a higher speed after negotiation. It improves link performance during adverse channel conditions by aggressive Adaptive Packet Assembly. It maximizes throughput by continuously monitoring line quality and link performance, and dynamically upshifting or downshifting to the optimum modulation speed.

Class 5 provides data compression, which combined with MNP Class 4 allows throughput of almost twice the connection speed. Class 5 dynamically adjusts to the type of data being transmitted for maximum compression efficiency.

Other Classes of MNP

MNP Class 2 uses standard asynchronous framing techniques for data transmission and error correction. Because of this protocol overhead, the actual throughput is less than the bps rate of the modem.

MNP Class 3 uses synchronous framing techniques. Removing start and stop bits associated with each character prior to transmitting results in a 20% performance increase over Class 2. Thus, actual throughput is greater than the modem's bps rate.

MNP Class 4 uses synchronous framing techniques plus improvements developed by Microcom Adaptive Packet Assembly and Optimized Data Phase. These enhancements result in better performance for all types of connections.

Adaptive Packet Assembly automatically adjusts the size of the data packets based on the quality of the telephone line. When the line quality is good and there are few retransmissions, the modem increases the packet size. When the line quality is poor and retransmissions are frequent, the size of the packet decreases in order to maintain high throughput during error correction under poor conditions.

Optimized Data Phase is the redesign of the MNP protocol header that reduces the number of overhead bytes per data packet. For example, modems operating at Class 4 service transmit data at 2,900 bps.

MNP Class 6 allows half-duplex, fast-train, high-speed reliable connections with other MNP Class 6 modems at speeds of 4,800 to 9,600 bps.

Universal Link Negotiation allows the modem to automatically connect with other MNP modems at the highest common speed and protocol.

Statistical Duplexing adjusts the line bandwidth and data traffic flow during reliable connections to achieve maximum throughput.

MNP Class 7 provides Enhanced Data Compression, which combined with Class 4 allows throughput of more than twice the connection speed. MNP Class 7 Enhanced Data Compression not only dynamically adjusts to the type of data being transmitted, but allows for the probability of character frequency, for superior compression efficiency.

MNP Class 9 includes enhanced Universal Link Negotiation.

Diagnostics

Your modem's diagnostic capabilities verify its performance and can isolate the source of a communications problem. If a problem exists, test *all* components of the communications path, including the data cable and all connectors.



The modem must be in normal or direct mode for loopback tests. It does not support these tests in Bell 103, V.13, V.21, or V.23 mode.

The modem supports all loopback tests 1,200 bps or higher.

Power-Up Diagnostics

Power-up diagnostics test the program checksum, RAM memory, and components on the modem board each time you power up the modem or type: **AT\$D** .

Performing a Power-Up Diagnostic Test

To perform a power-up diagnostic test, enter the following at the command prompt:

AT\$D .

Local Analog Loopback with Self-Test

Local Analog Loopback with Self-Test tests the local serial port. The modem sends itself a test data sequence and then verifies the data to make sure that it receives them correctly.

Initiate a Local Analog Loopback using the **&T8** command.

Using Commands to Perform a Local Analog Loopback with Self-Test

To initiate a Local Analog Loopback with Self-Test, type **AT&T8** . When the test finishes, the screen displays a three-digit number that represents the number of errors. For example:

```
AT&T8  
(no display during test)  
(test ends)  
000  
OK
```

The test continues until the time set with register S18 runs out, or until you terminate the test by typing **AT&T0** . You can also type **ATH** to end the test and hang up.

Local Analog Loopback

Local Analog Loopback tests the local serial port and the local computer. This test requires you to type a sequence of characters at your computer. The modem then sends these characters back to your computer.

Initiate a Local Analog Loopback test by using the **&T1** command.

Using Commands to Perform a Local Analog Loopback

To initiate a Local Analog Loopback:

1. **Type: **AT&T1** (must be the last command on the line).**
2. **Type a sequence of characters.**

The characters on your display should match exactly the characters you type. This test mode continues for the time set with register S18, or until you manually terminate the test. To manually end the test, enter command state and type: **AT&T0** . To end the test and hang up, type: **ATH** .

Remote Digital Loopback with Self-Test

Remote Digital Loopback with Self-Test tests the remote modem port, the telephone line, and the local serial and modem ports. When the modem is set to Remote Digital Loopback with Self-Test, it sends the remote modem a special test data sequence, and the remote modem echoes this data back to your modem.

To initiate a Remote Digital Loopback with Self-Test:

1. **Dial the number of a remote system configured to accept a Remote Digital Loopback request.**
2. **When the modems connect, return to command state and type:**
AT&T7

When the test is complete, the screen displays a 3-digit number that represents the number of errors. For example:

```
AT&T7  
(no display during test)  
(test ends)  
000  
OK
```

The test continues for the time set with register S18 or until you terminate the test by typing **AT&T0** . To end the test and hang up, type: **ATH** .

Remote Digital Loopback

Remote Digital Loopback tests the remote modem port, the telephone line, the local serial and modem ports, and the local computer. This test requires you to type a sequence of characters at your computer. The modem then sends these characters to the remote modem, which echoes them back to your modem.

Initiate a Remote Digital Loopback by using the `&T6` command.

Using Commands to Perform a Remote Digital Loopback

To initiate a Remote Digital Loopback:

1. **Dial the number of a remote system configured to accept a Remote Digital Loopback request.**
2. **When the modems connect, return to the command state and type: `B`**
3. **Type a sequence of characters.**

The characters echoed on your display should match exactly the characters you typed. The test continues for the time set with register S18, or until you manually terminate the test. To manually end the test, enter command state and type:

AT&T0 .

To end the test and hang up, type:

ATH

Local Digital Loopback

Local Digital Loopback allows the modem to loop back data to the remote modem. It tests the remote computer, the remote modem and serial ports, the telephone line, and the local modem port.

Initiate a Local Digital Loopback by using the &T3 command.

Using Commands to Perform a Local Digital Loopback

To initiate a Local Digital Loopback:

1. **Dial the number of a remote system.**
2. **When the modems connect, return to the command state and type: AT&T3**

The operator of the remote system now types a sequence of characters.

You do not see any characters on your display while your modem echoes the characters typed by the operator of the remote modem back to the remote computer. The test continues for the time set with register S18. If you do not use register S18, the operator of the remote modem must hang up or call you on another telephone line to tell you when the test is over. To manually end the test, enter command state and type: **AT&T0**

To end the test and hang up, type: **ATH**

Respond to Remote Digital Loopback

The Respond to Remote Digital Loopback command configures your modem to accept a request from a remote modem to engage in a Remote Digital Loopback or a Remote Digital Loopback with Self-Test. To configure the modem to accept a remote digital loopback request, at the command prompt type: **AT&T4**

To configure the modem to ignore a remote digital loopback request, type: **AT&T5**

Automatically Terminating a Test: Register S18

To configure the modem to terminate a test automatically after a specified time, change the value of register S18. Register S18 determines the duration of a diagnostic test. The factory default setting is 0 seconds, which disables the timer and causes tests to continue indefinitely until you cancel them. You can set this register to terminate tests after 1 to 255 seconds.

Result Codes

The modem can display these result codes when it attempts to establish a connection. See *AT Commands and Registers* on page A-1 for descriptions of the commands.

Connection Result Code Tables

The tables use the abbreviations: **rel** (reliable) and **non-rel** (non reliable).

[Table 4-5](#) shows the short and long form result codes, excluding connection result codes whose form depends on the \V, W, and -M commands.

Table 4-5. Result Codes

Short Form	Long Form
0	OK
1	CONNECT
2	RING
3	NO CARRIER
4	ERROR
6 ¹	NO DIALTONE
7 ¹	BUSY
8 ¹	NO ANSWER
51	NO PROMPT TONE

¹ Display of these call progress monitoring result codes depends on the setting of the X command.

Table 4-6. Long Form Connect Result Codes

ATV1-M0W0 or ATV1-M0W1 Report DTE speed		
DTE Speed	Non-rel	\V1 rel, \V2 rel ¹ ,
	\V0 rel	\V3 rel, \V4 rel ¹ , \V5 rel ⁴
75	75	75/REL
300	300	300/REL
600	600	600/REL
1200	1200	1200/REL
2400	2400	2400/REL
4800	4800	4800/REL
9600	9600	9600/REL
19,200	19200	19200/REL
38,400	38400	38400/REL
57,600	57600	57600/REL
115,200	115200	115200/REL

Table 4-7. Long Form Connect Result Codes

ATV1-M0W2				
Report modulation speed				
Modulation	Speed	Non-rel \V0 rel	\V1 rel \V2 rel ¹	\V3 rel \V4 rel ¹ \V5 rel ⁴
V.21	300	__2&3	V.21/REL	V.21/REL
Bell 103	300	__2	103/REL	103/REL
V.23 half-duplex	1200	V.23 HDX ³	—	—
V.22	600 ³	600	600/REL	600/REL
V.22 \Bell 212A	1200	1200	1200/REL	1200/REL
V.34/V.22bis	2400	2400	2400/REL	2400/REL
V.34/V.32	4800	4800	9600/REL	4800/REL
V.34/V.32bis	7200	7200	9600/REL	7200/REL
V.34/V.32	9600	9600	9600/REL	9600/REL
V.34/V.32bis	12000	12000	9600/REL	12000/REL
V.34/V.32bis	14400	14400	14400/ REL	14400/REL

(continued on next page)

Table 4-7. Long Form Connect Result Codes (continued)

ATV1-M0W2 Report modulation speed				
Modulation	Speed	Non-rel \V0 rel	\V1 rel \V2 rel ¹	\V3 rel \V4 rel ¹ \V5 rel ⁴
V.34/V.FC	14400	14400	14400/ REL	14400/REL
V.34/V.FC	16800	16800	16800/ REL	16800/REL
V.34/V.FC	19200	19200	19200/ REL	19200/REL
V.34/V.FC	21600	21600	21600/REL	21600/REL
V.34/V.FC	24000	24000	24000/REL	24000/REL
V.34/V.FC	26400	26400	26400/REL	26400/REL
V.34/V.FC	28800	28800	28800/REL	28800/REL
V.34	31200	31200	31200/REL	31200/REL
V.34	33600	33600	33600/REL	33600/REL

¹ If \V2 or \V4 is set and a reliable link is established, the message displays as one of the following formats: **CONNECT <speed>/REL - MNP** or **CONNECT <speed>/REL - LAPM** or **CONNECT <speed>/REL - CELLULAR**.

² In non-reliable V.21 or Bell 103 connections, the message displays as **CONNECT**.

³ Not supported in synchronous mode.

⁴ If \V5 is set, the message displays as one of the following formats: **CONNECT <speed>/<modulation>REL - CELLULAR**, **CONNECT <speed>/<modulation>REL - LAPM**, or **CONNECT <speed>/<modulation>REL - MNP**, with the modulation /V.34, /V.FC, /V.32, /V.22, or /FSK

Table 4-8. Short Form (Numeric) Connect Result Codes

ATV0W0 or ATV0W1			
Report DTE speed			
DTE Speed	\V0 \V1 non-rel \V2 non-rel \V4 non-rel \V5 non-rel	\V1 rel \V2 rel \V4 rel \V5 rel	\V3
75	1	20	1
300	1	20	1
600	9	21	5
1200	5	22	5
2400	10	23	10
4800	30	31	11
9600	32	33	12
19200	36	37	14
38400	38	39	28
57600	42	43	29
115200	72	73	30

Table 4-9. ATV0W2 Report Modulation Speed

ATV0W2 Report Modulation Speed					
Modulation	Speed	\V0 \V1 non-rel \V2 non-rel \V4 non-rel \V5 non-rel	\V1 rel \V2rel	\V3	\V4 rel \V5 rel
V.21 or Bell 103	300	1 ¹	20	1 ¹	20
V.23 half-duplex	1200	5 ¹	—	5 ¹	—
V.22	600	9 ¹	21	5 ¹	21
V.22 or Bell 212A	1200	5	22	5	22
V.34/V.22bis	2400	10	23	10	23
V.34/V.32	4800	30	31	11	31
V.34/V.32bis	7200	40 ²	33	24	41
V.34/V.32	9600	32	33	12	33
V.34/V.32bis	12000	44 ²	33	25	45
V.34/V.32bis	14400	34 ²	35	13	35
V.34/V.FC	14400	34 ²	35	13	35
V.34/V.FC	16800	60	61	13	61
V.34/V.FC	19200	36	37	14	37
V.34/V.FC	21600	62	63	13	63
V.34/V.FC	24000	64	65	13	65
V.34/V.FC	26400	66	67	13	67
V.34/V.FC	28800	68	69	13	69
V.34	31200	70	71	13	94
V.34	33600	72	73	13	95



• Chapter 4 *The Internal Modems*



Appendix A

AT Commands and Registers

This chapter contains the following sections:

- *The Command Set.*
- *Entering Commands.*
- *Issuing AT Commands at any Speed.*
- *Command Descriptions.*
- *Register Descriptions.*

The Command Set

The modem responds to a superset of Hayes Smartmodem commands. (Additional commands use the prefixes \$, %,), *, -, :, @, and \.) The modem also stores configuration settings in a set of registers. These are similar to the Hayes Smartmodem registers, although some have enhanced modem features.



Factory defaults for commands and registers work with many installations; you may never need to change the default settings.

Entering Commands

Each command line must begin with the characters **AT** (the **AT**tention code). Both characters of the attention code must be in either upper case or lower case, but you may type the commands in any combination.

Type commands after the **OK** response. The modem ignores spaces between characters. If you make a mistake press the backspace key (**Ctrl** - **H**) and type the correct character. To make a command take effect, press **Enter**.

Issuing AT Commands at any Speed

You can enter AT commands at any supported serial-port speed up to 115,200 bps. Your modem automatically adjusts to the connection and command speeds (autobauds) up to 19,200 bps. Any time after you enter an AT at any speed up to 19,200 bps, you can enter commands at a new serial-port speed. If you enter a command at 38,400, 57,600, or 115,200 bps, **the serial port locks** at that speed. The serial-port default speed is 115,200 bps.

To unlock the serial-port speed and change to another speed:

- Enter an AT\$B*n* command (where *n* is any supported serial-port speed), or
- type AT%U to unlock the serial-port speed, then enter an AT at the new speed, or
- with &D2, or &D3 set, lower then raise DTR.

Commands

This section lists the modem AT commands in alphabetical order. A command argument printed in **bold** is the default setting.



In most cases, you will not need to change the default setting.

A/ Repeat Last Command

Re-executes the last command immediately. *The A/ command is not preceded by “AT” and not followed by .*

A Answer

Forces the modem to go off hook in answer mode, regardless of the value of register S0.

If result codes are enabled, your modem returns the result code **RING** (long form) or **2** (short form) when it receives a call.

%An Auto-Reliable Fallback Character

Where n is an integer between 0 and 127 indicating an ASCII character (Default is 0, auto-reliable fallback character disabled).

Sets the ASCII character recognized as the auto-reliable fallback character on the **answering** modem. In auto-reliable mode, when the modem encounters an incoming auto-reliable fallback character from the remote system, it automatically switches to normal mode and passes the character to the serial port. Auto-reliable fallback character recognition stops if the modem receives a SYN character (decimal 22).



Do not set $n=63$ or $n=126$. These settings interfere with V.42 negotiations.

With this command, **\N3\C2** must also be set.

\An Maximum MNP Block Size

- \A0** Sets block size up to a maximum of 64 characters.
 - \A1** Sets block size up to a maximum of 128 characters.
 - \A2** Sets block size up to a maximum of 192 characters.
 - \A3** Sets block size up to a maximum of 256 characters.
- Sets maximum block size for MNP stream link connections.

Bn ITU-T/Bell Mode

- B0** Uses ITU-T V.22 and V.21 standards at 1,200 and 300 bps.
- B1** Uses Bell 212A and 103 standards at 1,200 and 300 bps.

\$Bn Serial-Port Bps Rate

Where $n = 75, 300, 600, 1,200, 2,400, 4,800, 9,600, 19,200, 38,400, 57,600, 115,200$ bps.

Sets the serial-port bps rate when issued.

%Bn Modem-Port Bps Rate

Where $n = 75, 300, 600, 1,200, 2,400, 4,800, 7,200, 9,600, 12,000, 14,400, 16,800, 19,200, 21,600, 24,000, 26,400, 28,800, 31,200, 33,600$ bps.

When you enter this locally, the modem-port bps rate is set. Downshifting can still take place.



If **%G0** is set, an **AT** issued locally causes the modem-port speed to match the serial-port speed, regardless of any previous **%B** setting.

If **%G1** is set, the modem speed is changed only when you enter a **%Bn** command. Entering a **%F1**, **%F2**, or **%F3** causes a change to 1,200 bps.

\B n Transmit Break

Where n is an integer between 1 and 9 indicating the time (in increments of 100 milliseconds) to send the Break. (Default is 300 milliseconds.) During a reliable link the Break always equals 300 milliseconds.

Transmits a Break to the remote system from command state. To return to connect state, type: **ATO** (See also \K.)

%C n Compression Control

- %C0 Disables data compression.
- %C1 Enables MNP 5 Data Compression only.
- %C2 Enables V.42bis compression only.
- %C3** Enables both V.42bis and MNP 5 Data Compression. The modem matches the capability of the remote modem.

Determines whether the modem attempts to use data compression during reliable connections. ***We recommend leaving this command at its default (%C3).*** This allows the modem to establish a reliable connection using either MNP 5 Data Compression or V.42bis compression, depending on the capability of the remote modem.

Setting this command to 1 or 2 restricts the modem to using either MNP 5 Data Compression or V.42bis compression, respectively, or else a non-compression connection results.

If the remote modem does not support data compression or has it disabled, the modem can establish a connection without data compression, regardless of the modem's %C setting.



We recommend disabling **bps rate adjust** (\J0) for the most throughput.

With AT\J1 set, when the modem establishes a **reliable connection** at speeds between 4,800 and 16,800 bps, the serial port adjusts to 9,600 bps. If the connection speed is 19,200 or above, the serial port adjusts to 19,200 bps.

&Cn Serial-Port DCD Control

- &C0 DCD always On.
- &C1 DCD follows the state of the carrier from the remote system; DCD turns On after the connect message.
- &C2 DCD On except momentarily at disconnect.

Controls the Data Carrier Detect (DCD) signal on the serial port. Use this command if your computer requires CD to be Off at certain times. See also the **\D** command description.



The **&C** and **\D** settings are ignored while connected in V.23 half-duplex direct mode (%F3) or ITU-T V.13 (&R2).

Hardware flow control overrides the &C and \D settings for CTS operation. (See also \Q.)

@Cn CTS, DSR, and DCD Connect Message Control

- @C0 CTS, DSR, and DCD go On after the connect message is sent.
- @C1 CTS, DSR, and DCD go On before the connect message is sent.

Specifies whether CTS, DSR, and DCD go On before or after a connect message. Use this command with :T14.

\Cn Auto-Reliable Buffer

- \C0 Does not buffer data during link negotiation. Switches to normal or direct mode if no SYN character is detected within 3 seconds.

- \C1 Buffers all data on the **answering** modem until it receives either 200 non-SYN characters or a SYN character within 3 seconds (this delay is longer for modem speeds 300 or below). If it receives 200 non-SYN characters, the modem switches to normal mode and passes the data through to the serial port. If it detects a SYN character within 3 seconds, it attempts to establish a reliable connection. Otherwise, it switches to normal mode.
- \C2 Does not buffer data on the **answering** modem. Switches to normal mode upon receipt of a character defined by the AT%A command and passes that character to the serial port.

Determines if the answering modem set to auto-reliable mode and auto-answer buffers data from the remote modem during the 3 seconds when it tries to establish a reliable connection. When the modem receives calls both from modems that support MNP and from modems that do not, set \C2. This allows the modem to switch to normal mode as soon as it detects a log-on character (defined by %A) from a non-MNP caller. This eliminates the 3-second wait. (See the \N command description for more information about auto-reliable and normal modes.)

For example, use %A to set the auto-reliable fallback character to ASCII 13 (carriage return). Then set \C2\N3. Non-MNP callers who connect and press to log on do not have to wait for the 3-second auto-reliable window to expire before data can pass.



When either **\C1** or **\C2** is set, reliable and normal connections may result independent of bps rate adjust. However, when **\C0** is set bps rate adjust affects the type of connection as follows:

Reliable and direct connections may result when bps rate adjust is On (**\J1**).

Reliable and normal connections may result when bps rate adjust is Off (**\J0**).

When falling back to **V.23 full duplex connections** and either **\C1** or **\C2** is set, reliable and normal connections may result independent of the **\W** command.

D *<dial string>* Dial

Where *<dial string>* is a string of up to 98 characters. Do not type *<* or *>*. Valid dial string characters are: **0-9**, dial modifiers, and for tone dialing **A, B, C, D, #**, and *****. The modem ignores invalid characters. Dial strings longer than 98 characters produce an error message.

Dials a telephone number and attempts to establish a connection. The Dial command must be the last one on a command line.

To cancel the Dial command, press any key or use your data communications software to lower DTR (unless **&D0** is set).

To dial the telephone number 011 22 555 1234, type:

ATD 011225551234



After disconnect, there is a 5-second delay before the modem goes off hook in originate mode.

Dial Modifiers

Dial modifiers allow you to add conditions to the telephone number you dial. You can use several modifiers with the same telephone number. Dial modifiers include:

- ^A** **(Link Negotiation)** Perform link negotiation at 4,800 bps *for the current connection only*. (This dial modifier is equivalent to the *H2 command.)
- J** **(Link Negotiation)** Perform link negotiation at 1,200 bps *for the current connection only*. (This dial modifier is equivalent to the *H1 command.)
- K** **(Cell-Side Cellular Connection)** Sets)M1 *for the current connection only*.
- P** **(Pulse Dial)** Placed anywhere in the dial string, causes the modem to pulse dial. For example: **ATD P5551234**



Tone dial is the default setting. The last P or T dial modifier used remains in effect until you either issue a dial command with a different P or T modifier or reset the modem. Also, you can combine P and T dial modifiers within a dial string. For example, pulse dial a local telephone number and tone dial an access code and phone number; type:

ATD P5551234 T33 5556789

- R** **(Dial a Number in Answer Mode)** Must follow the last character in the dial string. Causes the modem to dial in answer mode when calling an originate-only modem. For example: **ATD 5551234R**
- T** **(Tone Dial)** Placed anywhere in the dial string, causes the modem to tone dial. For example: **ATD T12345**



Tone dial is the default setting. The last P or T dial modifier used remains in effect until you either enter a dial command with a different P or T modifier or reset the modem. You can combine P and T dial modifiers within a dial string. For example, pulse dial a local telephone number and tone dial an access code and phone number; type: **ATD P5551234 T33 56789**

W (Wait for Dial Tone Before Dialing) Inserted between digits in a dial string, causes the modem to wait for a second dial tone up to the register S7 time delay before dialing the number. If the modem receives a dial tone before the register S7 delay expires, it continues dialing. If it does not receive a dial tone, it displays **NO DIALTONE** and hangs up. For example: **ATD 5551234 W 5556789**



(Pause During Dial) Inserted in a dial string, causes the modem to pause for the register S8 delay before dialing the next digit. The default is 2 seconds. Use more than one comma for a longer pause. For example, when you need to dial “9” and pause for another dial tone before dialing an outside line:
ATD 9,,5551234

@ (Wait for Quiet Answer Before Dialing) Inserted between characters in a dial string, causes the modem to wait for the register S7 time delay, for at least one ring followed by five seconds of silence, before acting on the next character in the dial string. If the modem does not detect this sequence, it displays **NO ANSWER** and hangs up. Use this modifier when the system you are calling does not provide a dial tone. For example: **ATD 5551234 @ 43210**

! (Flash) Inserted between characters in a dial string, causes the modem to go on hook for 1/2-second and then go back off hook, as though you depressed the switch-hook button on your telephone.

- ;** **(Return to Command State After Dialing)** Added to the end of a dial string, tells the modem to remain in command state after it dials the digits preceding the semicolon. This allows you to enter dial strings longer than 98 characters. After the final Dial command, the modem tries to establish a connection. To abort dialing before you attempt to make a connection, type: **ATH**. Each Dial command *except the last one* must end with a semicolon. For example:

```
ATD 9,5551234;  
OK  
ATD 5556789 @ 55512345678 W 344
```

- \$** **(Bong Detect)** Detects an AT&T BELLCORE service prompt to enter a calling card number and authorization. When the modem encounters a “\$” modifier within a dial string, it waits to receive this “bong” signal. Once it detects it, the modem continues processing the dial string. If the time set by register S7 elapses first, the modem hangs up and displays **NO PROMPT TONE**.

Operating Mode Dial Modifiers

Use the following dial modifiers to override the `\Nn` command setting. Placed anywhere in the dial string, these modifiers cause the modem to override the `\Nn` setting *for that connection only*. For example, if your modem is set for `\N3` (auto-reliable) for answering and you are calling a modem that you know does not support error correction, use the **Z** dial modifier to force normal mode: **ATD 5551234Z**

- M** **(Dial in LAPM Mode)** Placed anywhere in the dial string, causes the modem to override current operating mode and dial in LAPM reliable mode for *the current connection only*.

- Q (Dial in LAPM Mode with Fallback to Normal)** Placed anywhere in the dial string, causes the modem to override current operating mode and dial in LAPM reliable mode with fallback to normal mode for *the current connection only*.
- U (Dial in Direct Mode)** Placed anywhere in the dial string, causes the modem to override current operating mode and dial in direct mode for *the current connection only*.
- V (Dial in LAPM Mode with Fallback to MNP)** Placed anywhere in the dial string, causes the modem to override current operating mode and dial in LAPM reliable mode with fallback to MNP for *the current connection only*.
- X (Dial in Auto-Reliable Mode)** Placed anywhere in the dial string, causes the modem to override current operating mode and dial in auto-reliable mode for *the current connection only*.
- Y (Dial in MNP Reliable Mode)** Placed anywhere in the dial string, causes the modem to override current operating mode and dial in MNP reliable mode for *the current connection only*.
- Z (Dial in Normal Mode)**
Placed anywhere in the dial string, causes the modem to override the current operating mode and dial in normal mode for *the current connection only*.

DL Redial the Last Telephone Number Dialed

Redials the last telephone number that the modem dialed.

%Dn Disconnect Buffer Delay

Where n is an integer from 0 to 255 representing seconds (Default is 0).

Sets a delay during which the modem attempts to process data in its transmit or receive buffer before disconnecting. When your software lowers DTR or you type **ATH** the modem attempts for n seconds to empty its transmit buffer before disconnecting. When carrier drops, it attempts for n seconds to empty its receive buffer before disconnecting. If its buffers are empty or if $n=0$, it disconnects without delay.

If a physical disconnect occurs (for example, the connection drops from too many retransmissions in reliable mode), the modem can process only the receive buffer. If the delay expires before the modem empties its buffers or it is in command state at disconnect, it may lose data.

&Dn DTR Control

- &D0 Ignores DTR. DTR not needed for auto-answer.
- &D1 Enters command state on detecting On-to-Off transition of DTR; DTR not needed for auto-answer.
- &D2 Goes on hook on detecting On-to-Off transition of DTR and prepares the serial port to accept an AT at any speed. DTR needed for auto-answer.
- &D3 Goes on hook and resets on detecting On-to-Off transition of DTR and prepares the serial port to accept an AT at any speed. DTR needed for auto-answer

The On-to-Off transition of DTR must last as long as the value specified in register S25 (default is 0.05 second). Positive transitions of DTR (Off-to-On) that occur within five seconds after disconnect are ignored.

-D Repeat Dial

-D <dial string>

Where <dial string> is a string of up to 98 characters. Valid dial string characters are: **0-9**, dial modifiers, and for tone dial, **#, A, B, C, D** and *****. The modem ignores invalid characters.

-DL Redials the last number dialed.
Redials a number up to 9 tries until connection. In reliable mode, it does not redial if a remote modem answers but fails to establish a reliable connection.

\Dn Serial-Port DSR/CTS Control

\D0 DSR and CTS always On.
\D1 DSR and CTS follow DCD. If &C1 is also set, DSR follows off hook.
\D2 DSR and CTS both follow DCD.
\D3 DSR complies with ITU-T recommendations, CTS always On.
\D4 DSR and CTS comply with ITU-T recommendations.
Controls the Data Set Ready (DSR) and Clear To Send (CTS) signals on the serial port.



Hardware flow control overrides &C and \D settings for CTS. (See \Q.)

The modem ignores **&C** and **\D** settings while connected in V.23 half-duplex direct mode (%F3).

When **\D4** is set, &D should be set to a value greater than 0.

ITU-T recommends that **DSR** come On when establishing a connection and drop when the connection ends.

ITU-T recommends that **CTS** follow DTR while in command state; drop either when answer tone is detected when originating, when going off hook when answering, or when connection ends; and follow connection status during connection.

The following table shows the &C and \D settings and the result of combining the two commands.

Table A-1. The &C and \D Settings

&C	\D	Result
0	0	DCD On, DSR On, CTS On
0	1	DCD On, DSR On, CTS On
0	2	DCD On, DSR On, CTS On
0	3	DCD On, DSR complies with the ITU-T recommendations, CTS On
0	4	DCD On, CTS/DSR comply with the ITU-T recommendations
1	0	DCD follows modem carrier, DSR On, CTS On
1	1	DCD follows modem carrier, DSR follows off hook, CTS follows DCD
1	2	DCD follows modem carrier, DSR and CTS both follow DCD setting
1	3	DCD follows modem carrier, DSR complies with the ITU-T recommendations, CTS On
1	4	DCD follows modem carrier, CTS/DSR comply with the ITU-T recommendations
2	0	DCD On (Off for a few seconds at disconnect only), DSR On, CTS On
2	1	DCD, DSR, and CTS On (Off for a few seconds at disconnect)
2	2	DCD, DSR, and CTS On (Off for a few seconds at disconnect)
2	3	DCD Off at disconnect then On, DSR complies with the ITU-T recommendations, CTS On
2	4	DCD On (Off for a few seconds at disconnect), CTS/DSR comply with the ITU-T recommendations

En Command Echo

E0 Inhibits the echoing of commands to the local device.

E1 Echoes commands to the local device.

%En Auto-Retrain

%E0 Disables the automatic retrain sequence.

%E1 Enables the automatic retrain sequence (at 2400 bps or higher).

When **%E1** is set and line quality is too poor to sustain communications, the modem tries up to three times to resynchronize the modems (for a total of up to six seconds) before hanging up. The modem can retrain during connections at 2,400 bps or higher. Use **ATO1** to force the retrain sequence when **%E0** is set.



The modem ignores **%E0** during V.34, V.FC, V.32bis, and V.32 connections.

-En Modem-Port Data Length

-E0 Enables 10-bit data during normal mode connections.

-E1 Enables 11-bit data during normal mode connections.

Determines the number of data bits used on the modem port during normal mode connections (when **\N0** is set) when the serial port is configured for asynchronous transmission of 11-bit characters. Both modems must be set to the same number of data bits.



The modems will not be able to pass data when a reliable connection (**\N3** or **\N5** is set) falls back to a normal connection with 11-bit data characters enabled on both modems.

:En Compromise Equalizer

- :E0** Disables the compromise equalizer only when the modem is in V.32bis or V.32 mode; may be useful for direct line connections or PBX-to-PBX connections.
- :E1** Enables the compromise equalizer; may be useful for outside-line-to-outside-line or PBX-to-outside-line connections. Controls equalization operation in V.32bis or V.32.

\En Data Echo

- \E0** Does not echo data sent by the local computer.
- \E1** Echoes data sent by the local computer.

When operating in connect state, determines whether the modem echoes characters sent from the local computer. \E1 functions only during normal mode connections.

%Fn V.23 Mode

- %F0** Allows multi-protocol answering; disables V.23 mode on originate modem.
- %F3** 1,200 bps transmit, 1,200 bps receive (half duplex) V.23 mode. Determines the V.23 mode used at 1,200 bps.



Entering **AT%Fn** ($n=1, 2, \text{ or } 3$) disables all protocols except V.23. Entering **AT%Bn** forces the **%F0** setting.

When **%F0** is set and the modem is at 1,200 bps or higher, it can answer as a V.23 1,200/1,200 bps half-duplex modem.

When **%F3** is set, the modem can only establish normal or direct 1,200 bps half-duplex connections.

The \S command shows **MODEM BPS V.23 AT** when the modem establishes V.23 connections.



Set **%G1** first *before* setting **%Fn**.

&F Restore Factory Defaults

Restores factory default settings.

-Fn Secondary Flow Control

- F0** Disables secondary flow control characters.
- F1** Enables secondary flow control characters.

Controls whether the modem sends or receives secondary flow control characters on the serial port. When **-F1** is set and primary flow control enabled on the serial port, the modem sends two flow control characters (one primary and one secondary) to the host for flow control processing.

If the modem receives either a primary or secondary XOFF flow control character, it stops sending data until it receives the corresponding primary or secondary XON character.

%Gn Independent Serial-Port/Modem-Port Speed

- %G0** Serial-port speed determines modem-port speed.
- %G1** %B command determines modem-port speed.

Determines whether the modem-port speed updates to match the serial-port speed with each AT command. When **%G1** is set, the modem-port speed does not update, and you must change it with a %B or %Fn command.

&Gn Guard Tone

- &G0** Disables guard tone.
- &G1** Sets guard tone on the answering modem to 550 Hz.
- &G2** Sets guard tone on the answering modem to 1800 Hz.

\Gn Modem-Port Flow Control

- \G0** Disables modem-port flow control.
- \G1** Sets modem-port flow control to XON/XOFF.
- \G2** Sets modem-port flow control to unidirectional XON/XOFF.

Sets the flow control method used to pace data between modems during a normal mode connection. When **\G1** is set, the modem sends an XOFF character to stop receiving data, and sends an XON character to resume. When **\G2** is set, the modem sends XON and XOFF characters to the remote device but ignores XON and XOFF characters from the remote device.



Reliable mode has its own method of flow control and ignores the \G setting, but \Qn settings remain active.

Both modems must have the same **primary flow control characters** set during normal connections. (See the :T9 and :T10 register descriptions.)

H Hang Up

- H0 Disconnects from the remote system and hangs up the telephone line.
- H1 Disconnects from the remote system and goes off hook in command mode.

The modem ignores ring signals and positive transitions of DTR for 5 seconds after disconnect.



If %D is set to a value other than 0, hang up may not occur immediately.

*Hn Link Negotiation Speed

- *H0 Link negotiation occurs at the highest supported speed.
- *H1 Link negotiation occurs at 1,200 bps.
- *H2 Link negotiation occurs at 4,800 bps.

Sets the connection speed for link negotiation for connections before upshift occurs between two MNP 10 modems. Use *H1 or *H2 to set speed to 1,200 or 4,800 bps, respectively, to facilitate link negotiation over poor phone lines.

In Identification

- I0 Displays the 4-digit modem product code.
- I1 Performs a checksum on firmware and displays 3-digit result.
- I2 Performs a checksum on the firmware ROM and displays the checksum status, which should display **OK**.
- I3 Displays modem name and firmware version.

-Jn Detect Phase

- J0 Disables the detect phase.
- J1 Enables the detect phase.

Indicates whether the originating modem sends the V.42 control sequence to the answering modem to determine the type of error correction it has enabled. The answering modem can have LAPM, MNP, or no error correction enabled. See the \N command description for the types of connections.

\Jn Bps Rate Adjust

- \J0 Disables the bps rate adjust feature.
 \J1 Enables the bps rate adjust feature.

After establishing a connection with \J1 set, the modem automatically adjusts its serial port to match the connection speed until disconnection. When \J0 is set, the serial-port rate is independent of the rate of the connection.

When the modem establishes a reliable connection at speeds between 4,800 and 16,800 bps with bps rate adjust enabled, the serial-port speed adjusts to 9,600 bps. If the connection speed is above 16,800 bps, the serial port adjusts to 19,200 bps. If you set the serial port to the modem's highest rate of 115,200 bps, turn off bps rate adjust to make sure that the serial port stays at 115,200 bps.



Refer to the %F command description for information about using the \J command during V.23 connections.

See the %Un command for information about resetting the serial-port bps rate. When \J1\C0\N3 are set, the modem uses direct mode instead of normal mode if a reliable connection is not established.

We recommend turning off **bps rate adjust** (\J0) when using data compression to retain the highest throughput.

-Kn MNP Extended Services

- K0 Disables MNP Extended Services.
- K1** Enables MNP Extended Services.
- K2 Enables MNP Extended Services without MNP indication during the answer detect phase.

MNP Extended Services allow two modems that support them to use MNP data services that are not available with LAPM. For example, negotiating MNP Class 10 with V.42bis compression in preference to LAPM.

\Kn Break Control

Where n is a number between 0 and 5 indicating the type of Break the modem transmits (Default is 5).

Determines the type of Break the modem transmits when a Break enters the modem. The following tables list the different effects of the n value when the modem receives or transmits the Break. The modem can buffer up to four Breaks on both the modem port and the serial port.



In reliable link connect state, the sender's Break control setting determines how the receiver handles the Break.

Table A-2 illustrates the **\Kn** command.

Table A-2. The \Kn Command

Command	Local DTE sends Break during reliable or normal connection	Local DTE sends \Bn; local modem in command mode, during reliable or normal connection	Local modem sends Break during direct connection	Remote modem sends Break during normal connection
\K0	Enter command state; no Break to remote system*	Empty data buffers; send Break to remote system	Send Break to remote system; set modem to command state	Empty data buffers; send Break to serial port
\K1	Empty data buffers; send Break to remote system	Same as \K0	Send Break to remote system	Same as \K0
\K2	Same as \K0*	Immediately send Break to remote system	Same as \K0	Immediately send Break to serial port
\K3	Immediately send Break to remote system	Same as \K2	Same as \K1	Same as \K2
\K4	Same as \K0*	Send Break to remote system in sequence with any transmit data being buffered	Same as \K0	Send Break to serial port in sequence with receive data being buffered
\K5	Send Break to remote system in sequence with transmit data	Same as \K4	Same as \K1	Same as \K4

* Forces the modem to command state. To transmit a Break and enter connect state, type: **AT\BO**

%Ln Speed Matching

- %L0 Provides partial speed matching.
- %L1 Enables speed matching.
- %L2 Disables speed matching.
- %L3 Enables V.8 Automode with fallback to ITU-T Automode.
- %L4 Enables V.8 Automode only.

Determines whether the modem uses speed matching to establish a connection.



Both modems must support the V.8 protocol when using %L4 or a connection will not be made.

Table A-3 and Table A-4 indicate the connections that the modem can establish when %L1 or %L3 is set.

Table A-3. Modem Connections when %L1 or %L3 is Set

Mode Setting on Originating Modem	Mode Setting on Answer Modem						
	V.22[b]	V.22[a]	V.22bis	V.32	V.32bis	V.FC	V.34
V.34 (2400-33,600)	—	V.22[a]	V.22bis	V.32	V.32bis	V.FC	V.34
V.FC (14,400-28,800)	—	V.22[a]	V.22bis	V.32	V.32bis	V.FC	V.FC
V.32bis (4800-14,400)	—	V.22[a]	V.22bis	V.32	V.32bis	V.32bis	V.32bis
V.32 (4800-9600)	—	V.22[a]	V.22bis	V.32	V.32	V.32	V.32
V.22bis (2400)	—	V.22[a]	V.22bis	V.22bis	V.22bis	V.22bis	V.22bis
V.22[a] (1200)	—	V.22[a]	V.22[a]	V.22[a]	V.22[a]	V.22[a]	V.22[a]
V.22[b] (600)	V.22[b]	—	—	—	—	—	—
Bell121A (1200)	—	V.22[a]	V.22[a]	V.22[a]	V.22[a]	V.22[a]	V.22[a]
Bell103 (300)	—	Bell103	Bell103	Bell103	Bell103	Bell103	Bell103



When both the originate and answer modems are V.8 modems, setting 300 bps will make a V.21 connection.

Table A-4. Modem Connections when %L1 or %L3 is Set

Mode Setting on Originating Modem	Mode Setting on Answer Modem	
	Bell212A	Bell103
V.34 (2400-33,600)	V.22[a]	—
V.FC (14,400-28,800)	V.22	—
V.32bis (4800-14,400)	V.22[a]	—
V.32 (4800-9600)	V.22[a]	—
V.22bis (2400)	V.22[a]	—
V.22[a] (1200)	V.22[a]	—
V.22[b] (600)	—	—
Bell212A (1200)	Bell212A	Bell212A
Bell103 (300)	Bell103	Bell103

The following chart indicates the connections that the modem can establish when %L4 is set. Both modems must support the V.8 protocol when using %L4 or a connection will not be made.

Table A-5. Modem Connections when %L4 is Set

Mode Setting: Originating Modem	Mode Setting: Answer Modem						
	V.22[b]	V.22[a]	V.22bis	V.32	V.32bis	V.FC	V.34
V.34 (2400-33,600)	—	V.22[a]	V.22bis	V.32	V.32bis	V.FC	V.34
V.FC (14,400-28,800)	—	V.22[a]	V.22bis	V.32	V.32bis	V.FC	V.FC
V.32bis (4800-14,400)	—	V.22[a]	V.22bis	V.32	V.32bis	V.32bis	V.32bis
V.32 (4800-9600)	—	V.22[a]	V.22bis	V.32	V.32	V.32	V.32
V.22bis (2400)	—	V.22[a]	V.22bis	V.22bis	V.22bis	V.22bis	V.22bis
V.22[a] (1200)	—	V.22[a]	V.22[a]	V.22[a]	V.22[a]	V.22[a]	V.22[a]
V.22[b] (600)	V.22[b]	—	—	—	—	—	—

To restrict the possible connections that can result, %L0 or %L2 can be set on originating or answering modem. If %L2 is set, modem and connection speeds are identical. Table A-6 shows the modem connections when %L0 is set.

Table A-6. Modem Connections when %L0 is Set

Modem Speed	Possible Connection Speed
300	300
600	600
1200	1200
2400	1200, 2400
4800	2400, 4800
7200	2400, 4800, 7200
9600	2400, 4800, 7200, 9600
12,000	2400, 4800, 7200, 9600, 12,000
14,400	2400, 4800, 7200, 9600, 12,000, 14,400
14,400V	14,400
16,800	2400, 4800, 7200, 9600, 12,000, 14,400, 16,800
19,200	2400, 4800, 7200, 9600, 12,000, 14,400, 16,800, 19,200
21,600	2400, 4800, 7200, 9600, 12,000, 14,400, 16,800, 19,200, 21,600
24,000	2400, 4800, 7200, 9600, 12,000, 14,400, 16,800, 19,200, 21,600, 24,000
26,400	2400, 4800, 7200, 9600, 12,000, 14,400, 16,800, 19,200, 21,600, 24,000, 26,400
28,800	2400, 4800, 7200, 9600, 12,000, 14,400, 16,800, 19,200, 21,600, 24,000, 26,400, 28,800
31,200	2400, 4800, 7200, 9600, 12,000, 14,400, 16,800, 19,200, 21,600, 24,000, 26,400, 28,800, 31,200
33,600	2400, 4800, 7200, 9600, 12,000, 14,400, 16,800, 19,200, 21,600, 24,000, 26,400, 28,800, 31,200, 33,600

%Mn Modulation Selection

- %M0** Allows connections through V.32bis.
- %M1** Allows connections through V.FC.
- %M2** Allows connections through V.34 (default).
Controls the modem's top modulation speed.

)Mn Power Level Adjustment for Cellular Telephone Connections

-)M0** For central site modems: Auto-adjustment (adjusts power level if remote modem is set to **)M1**). Use for MNP 10 modems that will connect to both cellular telephone and non-cellular telephone site modems.
-)M1** For cell-side cellular modems: Forces power-level adjustment. Adjusts the power levels during link negotiation for reliable connections to accommodate signaling requirements of cellular telephone equipment.

-Mn MNP Class Connect Messages

- M0** Disables MNP Class connect messages.
- M1** Enables MNP Class connect messages.

Determines whether MNP Class connect messages are displayed. The **-M1** setting overrides the **\V** command setting for long form connection result codes and the **W** command for serial-port connect messages.

When **-M1** is set and an MNP connection established, the connect message is **CONNECT MNPn/x**, where *n* equals the MNP Class (from 1 to 10) and *x* equals the type of data compression used (V.42bis or MNP Class 5). If **M1** is set, the message is **CONNECT MNPn/y/x**, where *y* equals **CELLULAR**. If the modems do not negotiate compression, the message is **CONNECT MNPn**.

During LAPM V.42bis connections when **-M1** is set, the connect message is **CONNECT LAPM/V42BIS**. During LAPM connections with no compression active, the message is **CONNECT LAPM**.

When **-M1** is set, the message during normal and direct connections is **CONNECT**.

The modem ignores this command with short-form result codes enabled by **V0**.

Setting **X0** will also override the **-M** setting by displaying only **CONNECT**.

See also “Result Codes” in Chapter 4 for a complete list of connect messages and result codes.

\Nn Operating Mode

\N0	Sets normal mode.
\N1	Sets direct mode.
\N2	Sets reliable mode.
\N3	Sets auto-reliable mode.
\N4	Sets LAPM reliable mode.
\N5	Sets LAPM reliable mode with fallback to normal mode.
\N6	Sets LAPM reliable mode with fallback to MNP reliable mode.



You can use dial modifiers to set the operating mode for a single call. See the D command description for details.

Normal mode (\N0) can communicate with nearly any modem. Error correction does not take place in normal mode.

Direct mode (\N1) does not buffer data and ignores flow control. Also, in connect state, the serial port always adjusts to the speed of the connection, regardless of the setting of `\Jn`. Error correction does not occur.



`\J0` disables the escape code sequence in direct mode.

Reliable mode (\N2) uses the MNP reliable link to provide error detection and automatic retransmission of data if an error occurs. This provides for error-free communications between your system and another that supports the MNP reliable link. When `\N2` is in effect, the modem disconnects if it fails to establish an MNP reliable link immediately after making a connection.

During an MNP reliable link, both modems should use flow control on the serial port. When one detects a transmission error, it holds data in a buffer while they retransmit.



You may not want to use certain other protocols, such as HP Block Mode, with MNP. Such protocols have particular timing requirements that can interfere with MNP's effectiveness.

Auto-reliable mode (\N3) allows the modem to communicate with remote systems which support the MNP or LAPM reliable link and with systems that do not support the reliable link. In auto-reliable mode, the answering modem looks for incoming MNP or LAPM protocol characters from the remote modem. If it detects them within approximately three seconds, it tries to establish a reliable link connection.

When the modem is set to auto-answer in auto-reliable mode, you can shorten this 3-second period by using the **%A** command with **\C2**.



If both modems are set to auto-reliable mode, a normal connection or no connection could result due to noise on the telephone line.

LAPM reliable mode (\N4) uses the LAPM reliable link to provide error detection and automatic retransmission of data if an error occurs. This ensures that communications between your system and the remote system are error-free. The remote system must also be equipped to handle a LAPM reliable link. The modem attempts to establish a LAPM reliable link immediately after making a connection. If the attempt fails, the modem disconnects.

LAPM reliable mode with fallback to normal mode (\N5) attempts to establish a LAPM reliable connection. If the LAPM connection attempt fails, the modem falls back to a normal connection.

LAPM reliable mode with fallback to MNP reliable mode (\N6) attempts to establish a LAPM reliable connection. If the LAPM connection attempt fails, the modem then tries to establish an MNP reliable connection.

Table A-7 indicates the type of connections, depending on the operating mode. **NC** indicates No Connection. Where more than one operating mode is in a column, the first mode is for the originating modem and the second mode is for the answering modem.



MNP Extended Services: In the chart, you can use MNP Extended Services for V.42 connections where LAPM appears if both modems are set with **-K1** or **-K2**.

Table A-7. Connection Types Depending on Operating Mode

Answering Modem	Originating Modem						
	\N0	\N1	\N2	\N3	\N4	\N5	\N6
\N0	normal	direct/ normal	NC	normal	NC	normal	NC
\N1	normal/ direct	direct	NC	normal/ direct	NC	normal/ direct	NC
\N2	NC	NC	MNP	MNP	NC	NC	MNP
\N3	normal	direct/ normal	MNP	LAPM	LAPM	LAPM	LAPM
\N4	NC	NC	NC	LAPM	LAPM	LAPM	LAPM
\N5	direct	direct/ normal	NC	LAPM	LAPM	LAPM	LAPM
\N6	NC	NC	MNP	LAPM	LAPM	LAPM	LAPM

On Enter Connect State

- O0** Enters connect state.
- O1** Begins an equalizer retrain sequence when operating at 2,400 bps or higher and then returns to connect state.

Type: **ATO1** to reduce errors due to loss of equalization when excessive bit error rates are present.

%On V.23 Equalizer Control;

- %O0** Disables equalizers in V.23 half-duplex mode.
- %O1** Enables equalizers in V.23 half-duplex mode.
Determines if equalizers are set in V.23 half-duplex mode. To avoid transmission errors during V.23 half-duplex connections, equalizer settings must be the same on both modems.

-On Serial-Port Parity

- O0 7 data bits, odd parity.
- O1 7 data bits, even parity.
- O2 7 data bits, mark parity.
- O3 7 data bits, space parity.
- O4** 8 data bits, no parity.
- O5 8 data bits, odd parity.
- O6 8 data bits, even parity.
- O7 8 data bits, mark parity.

Allows you to change the serial-port parity setting that is automatically set by the **AT** sequence.

You can also use the -O command to change the serial-port parity while connected to a remote device. Use this command when the local device supports XON/XOFF flow control and detects parity. This command ensures that all XON and XOFF characters generated by the modem have the correct parity.

You cannot change modem-port parity during a connection. When parity is required for a connection and is different than the parity set by the **AT** sequence, the parity must be set at the same time the dial command is issued and entered on the same command line.

For example:

AT-O4D12345



8 bits and mark parity. The **AT** sequence cannot be used to match 8 bit data with mark parity. Eight data bits plus mark parity can only be set by the **AT-O** command. If **-O7** is not set, the modem defaults to 8 data bits, no parity.

Space parity. The **AT** sequence cannot be used to match space parity; no parity is set instead. You must enter **AT-O3** to set space parity.

P Pulse Dial

Changes the current dialing mode to pulse. Tone is the default.

-Pn Check Parity

- P0** Ignores parity of special characters.
- P1** Processes special characters *only* if their parity matches that of the serial port.
- P2** Processes special characters *only* if their parity matches that of the serial port. Recognizes modem-port flow-control characters, however, *regardless* of their parity.

Controls checking of parity for XON and XOFF characters, the escape code sequence, and HP ACK characters. In command state, the modem sends all command echoes and command responses to the PC with parity that matches the serial port's.

With **-P0** or **-P1** set, all received data pass through to the computer at 8 data bits, no parity.

With **-P2** set, all received data pass through to the computer with parity corrected to match the serial-port parity.



The **-P** command is used only for 10-bit data; the modem ignores **-Pn** when it is set for 11-bit data.

Qn Quiet

- Q0** Enables output of result codes.
- Q1** Disables output of result codes.
- Q2** Disables answer mode result codes only.

Determines whether the modem sends result codes and status codes (**OK**, **BUSY**, **RING**, etc.) to your computer.

-Qn Fallback Modulation Speeds

- Q0** Disables fallback from a V.32bis or V.32 MNP reliable connection to an MNP reliable 2400 or 1,200 bps connection.
- Q1** Enables fallback from a V.32bis or V.32 MNP reliable connection to an MNP reliable 2,400 bps connection.
- Q2** Enables fallback from a V.32bis or V.32 MNP reliable connection to an MNP reliable 2,400 or 1,200 bps connection.

Controls whether the modem can fall back from a V.32bis or V.32 MNP reliable connection to a V.22bis MNP reliable connection at 2,400 bps or a V.22 MNP reliable connection at 1,200 bps. Fallback may occur when poor telephone lines cause excessive MNP retransmissions.

Fallback from a V.32bis or V.32 MNP reliable connection to a 4,800 bps V.32bis or V.32 MNP reliable connection is always enabled, regardless of the -Q setting. The modem always uses the V.22 standard when it falls back from a V.32bis or V.32 MNP reliable connection to a 1,200 bps MNP reliable connection, regardless of the **B** setting.

\Qn Serial-Port Flow Control

- \Q0** Disables flow control.
- \Q1** Enables bi-directional XON/XOFF flow control.
- \Q2** Enables unidirectional hardware flow control; the modem uses CTS to control the terminal.
- \Q3** Enables bi-directional hardware flow control.
- \Q4** Enables unidirectional XON/XOFF flow control.
- \Q5** Keeps CTS Off until connection for unidirectional hardware flow control.
- \Q6** Keeps CTS Off until connection for bi-directional hardware flow control; ignores RTS until connection.

Sets the type of flow control used on the serial port. If the serial-port speed is faster than the modem-port speed, data from your computer enter the modem faster than they leave.

The modem holds characters in a buffer and sends them out at the slower modem-port bps rate. When the buffer is full, flow control instructs your computer to stop transmitting data to the modem; the modem continues to send out the characters and empty the buffer. When there is room in the buffer, flow control instructs your computer to resume transmitting data to the modem.

For reliable connections, retransmissions can reduce the effective modem-port speed. If this occurs, flow control prevents buffer overflow.

During direct mode connections, the modem does not use flow control and ignores the \Q setting.



Hardware flow control overrides the &C and \D settings for CTS operation.

\Q1 enables bi-directional XON/XOFF flow control. Sending an XOFF character stops data transmission; sending an XON character restarts it. The modem generates XON and XOFF characters at the same parity as on the serial port. The serial port responds to XON and XOFF characters from the local computer in the same way.

\Q2 enables unidirectional hardware flow control. The modem turns CTS Off to signal the local computer to stop transmitting data, and turns CTS On to signal the local computer to resume transmitting data.

\Q3 sets bi-directional hardware flow control using the CTS and RTS signals. The modem uses the CTS signal to start and stop data transmission from the local computer. When RTS is Off, the modem stops transmitting data to the local computer. When RTS is On the modem resumes sending data.

\Q4 enables unidirectional XON/XOFF flow control. The modem serial port generates, but does not respond to, XON/XOFF flow control characters. This setting allows for computers to transmit data that has XON and XOFF data characters. The computer can still be set to respond to XON/XOFF flow control characters sent to it from the modem during serial-port flow control.

\Q5 enables unidirectional hardware flow control the same as \Q2, but also keeps CTS Off until a connection is established.

\Q6 enables bi-directional hardware flow control the same as \Q3, but also keeps CTS Off until a connection is established and ignores RTS while not connected.

%Rn Read All Registers

- %R0** Displays the contents of all S registers in decimal and hexadecimal integers in tabular format.
- %R1** Displays the contents of all :T registers in decimal and hexadecimal integers in tabular format.

&Rn RTS/CTS Options

- &R2** ITU-T V.13 emulates half-duplex over a full duplex line. Use **&R2** to simulate half-duplex operation.



The modem ignores &R during **asynchronous connections**.

Sn? Read Configuration Registers

Where n is an integer from 0 to 27, indicating a register, displays the contents in decimal form of the selected register.

&Sn DSR Options

- &S0** DSR always on.
- &S1** DSR complies with ITU-T recommendations.
- Controls the Data Set Ready (DSR) signal on the serial port.



&S0 is equivalent to setting \D0. &S1 is equivalent to setting \D3.

\S Read Online Status

Displays a list of modem commands and their current settings. This command also displays the active connection type, as well as the elapsed connect time and the telephone number most recently dialed.

The \S command displays several screens. Press any key to move to the next screen. To cancel the display, type the line-delete character – or send a Break.

T Tone Dial

Changes the current dialing mode to tone. Tone is the default.

&Tn Test and Diagnostics Commands

&T0	End test in progress.
&T1	Local analog loopback.
&T3	Local digital loopback.
&T4	Respond to remote digital loopback.
&T5	Do not respond to remote digital loopback.
&T6	Remote digital loopback.
&T7	Remote digital loopback with self-test.
&T8	Local analog loopback with self-test.



The modem does not support &Tn commands for Bell 103, V.13, V.21, and V.23 modes.

&T0 ends a test in progress without terminating a connection, and returns the local and remote modems to normal operation. If self-test is in progress, **&T0** reports any errors. **&T0** must be the last command on a command line.

&T1 makes the modem display the characters on your screen exactly as you type them. The modem must be in normal or direct mode and set to 1200 bps or higher.

&T3 allows a remote modem that does not support the ITU-T V.54 standard to perform a Remote Digital Loopback test with your modem. The modem must connect in normal or direct mode and be set to 1200 bps or higher.

&T4 allows the modem to respond to a remote caller's request to enter Remote Digital Loopback mode.

&T5 prevents the modem from responding to a Remote Digital Loopback request.

&T6 instructs the remote modem to initiate a Remote Digital Loopback. It is available only when the modem is connected in normal or direct mode and set to 1200 bps or higher.

&T7 instructs the remote modem to enter a Remote Digital Loopback with Self-Test. Upon completion of the test, the modem reports errors to the local device. This command is available only when the modem connects in normal or direct mode and is set to 1200 bps or higher.

&T8 makes the modem send itself the ITU-T V.54 test pattern and verify these characters. Upon completion of the test, the modem reports errors to the local device. This command is available only when the modem is in normal or direct mode and set to 1200 bps or higher.

\Tn Inactivity Timer

Where n is an integer from 0 and 90 in minutes (Default is 0).

Specifies the number of minutes the modem waits for data before automatically hanging up. \T0 (default) disables the inactivity timer. The inactivity timer is only available during normal and reliable link connections; the modem ignores it in direct mode.

%Un Clear Serial-Port Speed

- %U0 Allows the current serial-port speed change from any speed.
- %U1 Always keeps the current serial-port speed. To change serial-port speed, you *must* enter %U1 *each time* you change it.
- %U2 Allows the current serial-port speed change from any speed.



You do not need to issue %U when bps rate adjust causes the serial-port speed to change during a connection.

You must enter **AT%U0** when changing from 11-bit characters to 10-bit characters, and from 10-bit to 11-bit.

When the serial-port speed is set to 38,400 bps, you cannot change it until you enter an **AT%Un** or reset it.

To save the configuration even after the modem is reset, also issue either &W or *W.

Vn Result Code Form

V0 Sends short-form result codes.

V1 Sends long-form result codes.

Selects whether the modem sends long-form (verbose) or short-form (numeric) result codes to your computer. The format of the connection result codes is dependent upon the \V, W, and -M commands.

%V Display Modem Firmware Version

Displays the modem firmware main code version.

\Vn Error Correction Result Code Form

\V0 Uses standard long-form result codes: **CONNECT <speed>**

\V1 Adds **/REL** to long-form error correction result codes:
CONNECT <speed>/REL

\V2 Displays long-form error correction protocol result codes:
CONNECT <speed>/REL-MNP or **CONNECT <speed>/REL-LAPM** or **CONNECT <speed>/REL-CELLULAR**

\V3 Adds **/REL** to long form error correction result codes: **CONNECT <speed>/REL**. Displays Hayes-compatible short-form (numeric) result codes.

\V4 Displays long-form error correction protocol result codes:
CONNECT <speed>/REL-MNP or **CONNECT <speed>/REL-LAPM** or **CONNECT <speed>/REL-CELLULAR**

\V5 Displays \V4 plus modulation **V.34**, **V.FC**, **V.32**, or **V.22**.

Determines whether result codes indicate that a reliable link connection is in effect. The **W** setting determines the contents of the *<speed>* field. Setting **-M1** changes the format of the long-form connect result codes.

Even for a reliable connection, use **\V0** if the communications software does not expect to see a reliable link result code.

Use **\V1**, **\V2**, **\V3**, **\V4** or **\V5** when your software supports error correction result codes.

Use **V0V3** if your communications software requires Hayes-compatible connection result codes. Note that when **V1** is set to select long-form result codes **V3** is equivalent to **V1**.

Use **V3**, **V4** or **V5** to see actual connect speed.



When either **V1** or **V2** is set, the message **CONNECT 9600/REL** displays during 4800, 7200, and 12000 bps reliable connections. When either **V3** or **V4** is set, the actual modem bps rate displays for 4800, 7200, and 12000 bps reliable connections.

^V Display Bootstrap Revision

Requests modem to display its current flash memory bootstrap revision.

Wn Connection Speed Reporting

W0 Displays serial-port connect messages.

W1 Displays serial-port connect messages.

W2 Displays modem-port connect messages.

When **W0** or **W1** is set, the speeds reported in connect messages indicate the serial-port speed.

When **W2** is set, the speeds reported in connect messages indicate the modem-port speed.

When **X0** is set, **CONNECT** displays, regardless of **W** setting.

See the section entitled “Result Codes,” for a list of valid connect messages and result codes.

%Wn Pulse Digit Command

- %W0** n pulse digits dialed for each number.
- %W1** $n+1$ pulse digits dialed for each number.
- %W2** $10-n$ pulse digits dialed for each number.

For pulse dialing, determines whether the modem dials each number in a dial string n pulses, $n+1$ pulses, or $10-n$ pulses. For example, when **%W0** is in effect, it dials 6 with 6 pulses. However, with **%W1**, it dials 6 with 7 pulses; with **%W2**, it dials 6 with 4 pulses.



With **%W0** or **%W2** set, the modem dials digit 0 with 10 pulses. When **%W1** is set, digit 0 is dialed with 1 pulse.

&Wn Store Current Configuration

Stores current user profile n , where $n = 0$ to 3 (Default is 0).

Stores the active commands and certain S-registers. You store telephone numbers independently with the $\backslash Pn$ and $\&Zn$ commands. AT&W stores the serial-port speed and parity and the modem-port speed that are in effect when you enter &W.

AT&W does not store the following restricted S-registers:

S2 S3 S4 S5 S6 S7 S8 S9 S10 S11 S12

*Wn Store Complete Configuration

Stores complete user profile n , where $n = 0$ to 3 (Default is 0).

Stores all active commands and registers as well as the restricted S-registers not stored with &W. (See the &W command description.)

Save telephone numbers independently with the \Pn and &Zn= commands. The *W command saves the serial-port speed and parity and the modem-port speed in effect when you enter *W. See also the &W, &Y, and Z commands. Refer to the section entitled “Storing Multiple User Profiles” for details on multiple user profiles.



The &W and *W commands share the same stored configuration area. Issue one of these commands to override the other stored settings.

The &W command setting stores default settings for the restricted S-registers. If &W is issued after issuing *W, the default settings for the restricted S-registers are stored. If you change the setting of one of the restricted S-registers and want to save it, use the *W command instead of the &W command.

Xn Extended Result Codes

- X0 Modem ignores dial tone and busy signals. Displays **CONNECT** when it establishes a connection. Smartmodem 300 compatible.
- X1 Modem ignores dial tone and busy signals. Sends a connect result code including bps rate when it establishes a connection.
- X2 Modem ignores busy signals. Displays **NO DIALTONE** if it does not detect one within 5 seconds of dialing. Sends a connect result code reflecting bps rate when it establishes a connection.
- X3 Modem ignores dial tone. Displays **BUSY** if it detects a busy signal. Sends a connect result code reflecting bps rate when it establishes a connection.
- X4** Displays **NO DIALTONE** if it does not detect one within 5 seconds of dialing. Displays **BUSY** if it detects a busy signal. Sends a connect result code reflecting bps rate when it establishes a connection.

Determines whether the modem responds to dial tone and busy signals, and what kind of **CONNECT** result codes are displayed. Result codes are further controlled by the **Vn** command. Result codes indicate MNP reliable mode only when either **\V1**, **\V2**, **\V3**, **\V4**, **\V5** or **-M1** is set. When the modem ignores dial tone, it waits for the register **S6** time delay to expire and then dials regardless of whether a dial tone is present.



The “W” dial modifier causes the modem to wait for dial tone regardless of the X setting.

Xn XON/XOFF Pass-Through;

- \X0** Processes XON/XOFF flow control characters.
- \X1** Processes XON/XOFF flow control characters and passes them to the local or remote system so that the local or remote device also processes them.

Determines whether XON/XOFF flow control characters pass to the remote or local modem. With XON/XOFF flow control enabled on the serial port (**\Q1**) and pass through enabled (**\X1**), the modem also transmits to the remote device any XON and XOFF characters sent to the serial port from the local device.



With **\X0** set and XON/XOFF flow control enabled, local devices such as computers or printers may send XON and XOFF characters to the modem serial port. If the modem is already controlling data flow to the remote system, local flow control characters will not interfere with the connection. However, if **\X1** is set, local flow control characters also pass to the remote system. These characters intended for the local system may turn on the flow of data from the remote system before the modem is ready to receive more data, resulting in a loss of data.

Yn Long Space Disconnect

- Y0** Disables long space disconnect on receipt of H, or DTR drop if **&D2** or **&D3** is set.
- Y1** Enables long space disconnect on receipt of H, or DTR drop if **&D2** or **&D3** is set.

Sends a Break up to 4 seconds before disconnecting in response to an H command, or if DTR drops and either **&D2** or **&D3** is set. If **&D3** is set and DTR drops, the modem disconnects. If the answer modem sees the Break, it drops the connection.



Yn is available *only* during **normal** and **direct** connections.

Y1 must be set on both modems to take effect.

&Yn Designate Default User Profile

Selects user profile n , where $n = 0$ to 3 (Default is 0).

Designates which of four user profiles the modem loads into active configuration at power up, or when DTR drops when &D3 is set. It saves this command immediately after you enter it; you do not have to enter &W or *W. Also, when you enter &F, this command does not change.



You can use the &Y command to select a user profile. The setting takes effect immediately. When you reset or power up the modem, it restores the last user profile setting selected.

Zn Reset

Resets user profile n , where $n = 0$ to 3.

Hangs up the phone line and clears the modem and serial-port buffers. Also, restores commands and registers that you last saved with either &W or *, or the factory defaults if you have not entered an &W or *W.

To reset the modem, type: **ATZn** ($n = 0$ to 3). If **OK** does not appear, type: **ATQ** to enable result codes.

Registers

Some registers control a single function. Others control several functions and are bit mapped. We recommend bit mapped registers for reading modem status only; we suggest you *use commands to change the modem's settings*.

Commands to Change or Read Registers

Change the Value of a Register

$Sn=x$
:Tn=x Changes the value of S or :T register “ n ” to a new value “ x ”.

Change the Value of the Last Referenced S-Register

=x Changes the value of the last referenced S-register or the register pointed to with the **ATSn** command. For example, if the last register command used was **ATS0=2**, entering **AT=4** changes the value of register S0 from 2 to 4.

Display the Value of the Last Referenced S-Register

? Displays the value of the last S-register referenced in a read, write, or point to command.

Point to New Register

Sn Where *n* is an integer from 0 to 27, indicating a register, instructs the modem to point to the register whose location is *n*. This becomes the last referenced register. For example, typing **ATS1** places the pointer at register S1 and returns the command prompt.

Read All Registers

%Rn

%R0 Displays the contents of all S registers in decimal and hexadecimal integers in tabular format.

%R1 Displays the contents of all :T*n=n* commands in decimal and hexadecimal integers in tabular format.

Read Configuration Register

Sn? Where *n* is an integer from 0 to 27, indicating an S register.

:Tn? Where *n* is an integer from 0 to 29, indicating a :T register. Displays the contents in decimal form only of register “*n*”.

Register Descriptions

S0=*n* Ring to Auto-Answer On.

Range: 0 - 255 rings.

Default: 1 ring (auto-answer enabled).

Sets the number of rings required before the modem answers.

ATS0=0 disables auto-answer.



The modem ignores ring signals for 5 seconds after disconnect.

S1=n Ring Counter

Range: 0 - 255 rings.

Default: 0 rings.

Keeps a running total of the number of rings that occur before the modem answers a call. If no ring occurs within 8 seconds after the last ring, the ring counter resets to 0.



The modem ignores ring signals for 5 seconds after disconnect.

S2=n Escape Code Character

Range: 0 - 255, ASCII decimal.

Default: 43 (+)

Sets the character used for the three-character escape code sequence. When the modem is in connect state and receives the escape code sequence, it enters command state. Setting register S2 to 0 disables the escape code character. See register S12 to set the guard time that brackets the escape code character.



The modem does not store this register with &W; enter *W to save it.

S3=n Carriage Return Character

Range: 0 - 127, ASCII decimal.

Default: 13 (carriage return).

Sets the character recognized as a carriage return. The carriage return terminates command lines and result codes.



The modem does not store this register with &W; enter *W to save it.

S4=*n* Line Feed Character.

Range: 0 - 127, ASCII decimal.

Default: 10 (linefeed).

Sets the character recognized as a line feed. The line feed character follows the carriage return at the end of command lines and result codes.



The modem does not store this register with &W; enter *W to save it.

S5=*n* Backspace Character

Range: 0 - 32, ASCII decimal.

Default: 8 (backspace).

Sets the character recognized as a backspace.



The modem does not store this register with &W; enter *W to save it.

S6=*n* Wait Before Dialing

Range: 2 - 255 seconds.

Default: 2 seconds.

Sets the length pause after off hook before the modem dials. The modem always pauses for a minimum of two seconds, even if S6 is set less than 2.



Register S6 is valid only when either X0, X1, or X3 is set.

The modem does not store this register with &W; enter *W to save it.

S7=*n* Wait for Carrier After Dial

Range: 0 - 255 seconds.

Default: 60 seconds.

Sets the length of time that the modem waits for:

- Carrier from remote modem before hanging up (originate or answer mode).
- Ring back (originate mode only, and only if either X3 or X4 is set).
- Dial tone when the “W” dial modifier is encountered in a dial string.
- Quiet answer when the “@” dial modifier is encountered in a dial string.



The modem does not store this register with &W; enter *W to save it.

S8=*n* Pause Time for Dial Delay

Range: 0 - 255 seconds.

Default: 2 seconds.

Sets the length of time to pause when the modem encounters the pause dial modifier (“,” - comma).



The modem does not store this register with &W; *W to save it.

S9=*n* Carrier Detect Response Time

Range: 0 - 255 tenths of a second.

Default: 6 (0.6 seconds).

Determines how long a signal must be present before the modem recognizes it as a carrier.



The modem does not store this register with &W; enter *W to save it. Register S9 is only used in normal and direct modes.

S10=*n* Delay for Hang Up After Carrier Loss

Range: 0 - 255 tenths of a second.

Default: 60 (6 seconds).

Sets the length of time the modem waits before hanging up loss of carrier, allowing for a temporary loss. Both modems should have equal S10 values. Otherwise, disconnect occurs when the lower value is reached. When register S10 is set to 255, the modem functions as if carrier is always present.

After disconnecting, the modem waits for a minimum of five seconds before going off hook again in originate mode.



The modem does not store this register with &W; enter *W to save it.

Register S10 is ignored during V.34, V.FC, V.32bis, V.32, V.22bis, and V.22 reliable connections.

S11=*n* DTMF Tone Dialing Speed

Range: 50 - 100 milliseconds.

Default: 75 milliseconds.

Sets the length of time after the last tone and before the next tone is sent when the modem is dialing over a touch tone line.



The modem does not store this register with &W; enter `*W` to save it.

S12=*n* Escape Code Guard Time

Range: 0 - 255 (fiftieths of a second).

Default: 50 (1 second).

Sets the minimum “quiet” time that must be present before and after entering the escape code. The delay between each character in the escape code must be less than this guard time. If register S12 is set to 0, the time it takes to enter the escape code does not affect recognition.



The modem does not store this register with &W; enter `*W` to save it.

Register S12 sets the guard time that precedes and follows the attention character sequence. It should be set to the same value on both the originating and answering modems.

S14=*n* Bit Mapped Register

The modem saves the following command settings when you enter them. You do not need to enter &W or *W also.

Table A-8. Saved Command Settings with S14

Bit Position	Function	Decimal Value	
0	not used		
1	command echo	0	no echo
		1	echo
2	result codes	0	result codes
		1	no result codes
3	result type	0	short form
		1	long form
4	dumb mode	0	smart mode
		1	dumb mode
5	dial method	0	tone dial
		1	pulse dial
6	not used		
7	originate/answer	0	answer mode
		1	originate mode

S16=*n* Bit Mapped Register, Test Options

Table A-9. Saved Command Settings with S16

Bit Position	Function	Decimal Value	
0	Local Analog Loopback	0	disabled
		1	enabled
1	not used		
2	Local Digital Loopback	0	disabled
		1	enabled
3	Remote Digital Loopback status (initiated by the remote modem)	0	loopback Off
		1	loopback in progress
4	Initiate Remote Digital Loopback	0	disabled
		1	enabled
5	Initiate Remote Digital Loopback with Self-Test	0	disabled
		1	enabled
6	Initiate Local Analog Loopback with Self-Test	0	disabled
		1	enabled
7	not used		

The modem does not support diagnostics in Bell 103, V.13, V.21, or V.23.



Commands enable and disable loopback test options.

Register S16 is a read-only register that displays loopback test option status, and is available only when the modem is in normal or direct mode. The modem supports all loopback tests at 1200 bps or higher. S18=*n* Test Timer

Range: 0 - 255 seconds.

Default: 0 seconds (disables timer).

Sets how long the modem conducts a loopback diagnostic test.

Register S18 is available only in normal or direct mode. When S18 is set to 0, type **AT&T0** to end a test.

S21=*n* Bit Mapped Register

Table A-10. Saved Command Settings with S21

Bit Position	Function	Decimal Value	
3,4	DTR	0	Ignores DTR (&D0)
		1	On-to-Off DTR transition: modem enters command state (&D1)
		2	On-to-Off DTR transition: modem goes on hook (&D2)
		3	On-to-Off DTR transition: modem resets (&D3)
5	DCD	0	DCD always On
		1	DCD On indicates data carrier is present or DCD On except momentarily at disconnect
6	not used		
7	long space	0	off (Y0)
	disconnect	1	on (Y1)

S22=*n* Bit Mapped Register

Table A-11. Saved Command Settings with S22

Bit Position	Function	Decimal Value	
4,5,6	result code	0	same as X0
	options	4	same as X1
		5	same as X2
		6	same as X3
		7	same as X4
7	make/break	0	39/61
	ratio	1	33/67

S23=*n* Bit Mapped Register

Table A-12. Saved Command Settings with S23

Bit Position	Function	Decimal Value	
0	respond to remote digital loopback	0	disabled
		1	enabled
1,2,3	serial-port bps	0	0 to 300 bps
		1	600 bps
		2	1200 bps
		3	2400 bps
		4	4800 bps
		5	9600 bps
		6	19200 bps
		7	38400, 57600 and 115200 bps
4,5	parity option	0	even
		1	space/none
		2	odd
		3	mark
6,7	guard tones	0	disabled
		1	550 Hz
		2	1800 Hz
		3	not used

The modem ignores the Respond to Remote Digital Loopback option during reliable connections.



you use register S23 to change the parity set automatically or set by -On, the same number of data and stop bits used before the change is retained. For example, if 8 data bits and even parity is set (-O6) and you change register S23 to odd parity, the 8 data bits and 1 parity bit are retained. However, the parity becomes odd instead of even, changing the Serial-Port Parity command setting to -O5.

S25=*n* Delay to DTR and Asynchronous Time Delay

Range: **Delay to DTR:** 0 - 255 hundredths of a second.
Async mode: 0 - 255 seconds.

Default: **Delay to DTR:** 5 hundredths of a second (0.05 seconds).
Async mode: 5 seconds and 0.05 seconds.

Delay to DTR: During asynchronous mode with **&M2** or **&M3** set, the modem ignores an On-to-Off transition of DTR that is less than the register S25 time delay.

Asynchronous time delay: Register S25 sets the number of seconds the modem waits to check DTR after establishing a connection. After this time delay, the Delay to DTR time delay described above takes effect when loss of DTR occurs. S26=*n*RTS to CTS Delay Interval.

S27=*n* Bit Mapped Register

Table A-13. Saved Command Settings with S27

Bit Position	Function	Decimal Value	
6	answer tone when at 1200 bps	0	ITU-T V.22bis/V.22
		1	Bell 212A when supported
7	not used		

:T0=*n* Timer for V.22bis, V.22, and V.32 Modes During Multi-Protocol Answer

Where *n* is an integer from 0 to 255, in tenths of a second
Default is 40 (4 seconds).

This command requires 1200 bps or higher operation with **%F0%L1** set.

Determines how long the modem attempts to establish a V.32, V.22bis, or V.22 connection before attempting to establish a V.21 connection. During this period, the modem sends V.22bis or V.22 carrier.

:T2=*n* Timer for V.21 Mode During Multi-Protocol Answer

Where *n* is an integer from 0 to 255 representing tenths of a second. Default is 0 (V.23 half duplex disabled).

This command requires 1200 bps or higher operation with **%F0%L1\N3** set.

When the modem is unable to establish a V.32, V.22bis, or a V.22 connection, :T2 determines how long the modem attempts to establish a V.21 connection before attempting a V.23 half-duplex connection. During this period, the modem sends V.21 carrier.

Set **:T2=20** (2 seconds) when including V.23 half duplex in the multi-protocol answer modem.



:T2 is set to 0, V.23 half-duplex connections are not attempted. The modem attempts to establish a connection for the length of time specified by register S7 before hanging up.

:T3=*n* Timer for V.21 and V.23 Answer Tone Duration

Where *n* is an integer from 0 to 33 (tenths of a second)
Default is 33 (3.3 seconds).

This command requires either V.21 operation (**%F0** is set and the modem speed is 300 bps) or V.23 operation (**%Fn**, where *n*=1, 2, or 3).

When the **answering modem** is set for V.21 or V.23 operation, :T3 determines the duration of the V.25 answer tone that is sent to the originating modem. When :T3 is set to 0, no answer tone is sent. All V.21 and V.23 answers begin with two seconds of silence unless :T3 is set to 0.

When the **originating modem** is set for V.21 or V.23 operation, :T3 determines how long the modem waits after detecting answer tone before proceeding with the connection. When :T3 is set to 0, the originating modem does not wait for answer tone.

:T4=*n* Timer for Line Turnaround Delay - Carrier On

Where *n* is an integer from 0 to 255 (in increments of 12.5 milliseconds). Default is 20 (250 milliseconds).

This command takes effect only during normal mode V.23 half-duplex connections.

After the modem turns carrier off, determines the minimum time the modem waits for the remote modem to respond before turning carrier back on again to resume sending data.

:T5=*n* Timer for V.23 Half-Duplex Intercharacter Delay

Where *n* is an integer from 0 to 255 (in increments of 12.5 milliseconds) Default is 7 (87.5 milliseconds).

This command takes effect only during normal mode V.23 half-duplex connections.

Sets the length of time the modem waits after transmitting the last data character in the transmit buffer before turning carrier off. :T5 may need to be adjusted if the local computer intercharacter time causes excessive line turnarounds.

:T6=*n* Timer for DCD Turn On Delay

Where *n* is an integer from 0 to 255, representing milliseconds.

Default is 200 milliseconds (2 tenths of a second).

This command takes effect during only normal mode V.23 half-duplex connections.

Sets how long the modem waits after carrier goes on before it starts looking for data. This command may be set to exclude the turn on noise that occurs when DCD turns On during V.23 half-duplex connections.

If :T6 is set to 0, the modem waits 256 milliseconds before looking for data.

:T7=*n* Timer for False Answer Abort

Where *n* is an integer from 0 to 255, representing seconds
Default *n*=60 seconds; setting :T7=0 disables this timer.

This command takes effect only when the modem falls back to a normal mode V.23 half-duplex connection.

Sets the amount of time the modem waits before hanging up when it receives no data. If this command is set to a value greater than zero, the timer starts when the modem connects. If the modem does not receive data in the specified time, it hangs up.

:T9=*n* Primary XON Flow Control Character

Where *n* is a decimal from 0 to 255, representing an 8-bit character. Default *n*=11 hexadecimal (or 17 decimal) <DC1>.

Defines the character used for primary XON flow control on the modem and serial ports. Enable primary flow control with \Q1, \Q4, \G1, or \G2.



With modem-port flow control, both modems must have the same primary flow control characters set during normal connections.

:T10=*n* Primary XOFF Flow Control Character

Where *n* is a decimal from 0 to 255, representing an 8-bit character. Default is 13 hexadecimal (or 19 decimal) <DC3>.

Defines the character used for primary XOFF flow control on the modem and serial ports. Enable primary flow control with **\Q1**, **\Q4**, **\G1**, or **\G2**.



With modem-port flow control, both modems must have the same primary flow control characters set during normal connections.

:T11=*n* Secondary XON Flow Control Character

Where *n* is a decimal from 0 to 255, representing an 8-bit character. Default is F9 hexadecimal (or 249 decimal).

Defines the character used for secondary XON flow control on the modem's serial port. For secondary flow control to take effect, you must set either **-F1\Q1** or **-F1\Q4**.

:T12=*n* Secondary XOFF Flow Control Character

Where *n* is a decimal from 0 to 255, representing an 8-bit character. Default is FB hexadecimal (or 251 decimal).

Defines the character used for secondary XOFF flow control on the modem serial port. For secondary flow control to take effect, you must set either **-F1\Q1** or **-F1\Q4**.

:T14=*n* Connect Message Delay Timer

Where *n* is an integer from 0 to 255, in 100 millisecond interval. Default is 0.

Specifies how long to wait before or after a connect message before CTS, DSR, DCD go high. Use this command with @**C*n*** (where *n*=0 or 1).

:T15=*n* V.24 Control Register

Where *n* is an integer from 0 to 255 (see below for the valid values for *n*). Default is 149.

This command is bit-mapped and used as follows:

Table A-14. T15 Command Settings

Bit Position	Function	
1		not used
2	0	RTS is ignored while not connected when &R0 or &R2 set
	1	CTS follows RTS when not connected when &R0 or &R2 set
3		not used
4		not used
6	0	CD follows link negotiation connection status
	1	CD always follows modem carrier when &C1 is set
7	0	V.32 answer tone without phase reversals
	1	V.32 answer tone with phase reversals

:T16=*n* CTS Turn On Delay Timer

Where *n* is an integer from 0 to 255 (in increments of 12.5 milliseconds). Default is 0.

After DCD and/or DSR have been turned On while connecting, determines how long the modem waits before turning On CTS.

:T17=*n* V.32/V.32bis Connection Training Timer

Where *n* is an integer from 0, 1, 5 to 32.

Default is 0, use dynamic training sequences — equivalent to a setting of 28.

Controls the length of the training sequences exchanged when trying to establish V.32 and V.32bis connections.

Reduce the time required to establish a connection by setting :T17 to a value less than 28; this increases the modem's sensitivity to noise on the line.

Reduce the modem's sensitivity to noise by setting :T17 to a value greater than 28; this lengthens the time required to make a connection.

:T19=*n* Bit Mapped Register

Where *n* is an integer from 0 to 255 (see below for the valid values for *n*). Default is 1.

This command controls MNP link control as follows:

Table A-15. MNP Link Control

Bit Position	Function	
0	0	Modem keeps a non-MNP10 1200 bps connection if no MNP link activity is received from the remote modem
	1	Modem disconnects a non-MNP10 1200 bps connection if no MNP link activity is received from the remote modem for two minutes

:T22=*n* DSR Timer

Where *n* is an integer from 0 to 255 (in increments of 12.5 milliseconds). Default is 34 (425 milliseconds).

After DCD and/or CTS drop, :T22 identifies how long the modem waits before DSR is dropped when disconnecting. For example, if \D2 and &C1 are set, when DCD and CTS drop, the modem then waits the amount of time specified by :T22 before dropping DSR.

:T23=*n* Bit Mapped Register

Table A-16. :T23 Settings

Bit Position	Function	Decimal Value
0,1	not used	
4	Rate negotiation at start-up	1. At the start of a V.32 connection, makes modem examine line quality and set speed accordingly 2. Disabled
6,7	not used	

:T26=*n* Bit Mapped Register

Table A-17. :T26 Settings

Bit Position	Function	
0	0	Enables 2-second billing delay
	1	Disables 2-second billing delay This bit decreases connection time, but may affect attaining connections
1	0	Normal answer tone length in V.32 mode
	1	Shortens answer tone length in V.32 mode

:T42=n V.34/V.FC Connection Speed Selection

- 0** Default V.34/V.FC connection speed selection.
- 1** Highest V.34/V.FC connection speed selection (about 2 speeds above default).
- 2** Higher V.34/V.FC connection speed selection (about 1 speed above default).
- 3** Default V.34/V.FC connection speed.
- 4** Lower V.34/V.FC connection speed (about 1 speed below default).
- 5** Lowest V.34/V.FC connection speed (about 2 speeds below default).

Allows you to change the V.34/V.FC connection speed according to line quality. We recommend leaving this register at its default setting.

If you notice that your modem falling back during V.34/V.FC connections, or that you are seldom able to make 33,600 connections, you can try the lower settings of this register.

- T registers, displaying A-39
- T registers, overview A-50
- T17 and
 - T27 with cellular connections 4-8
- T2 and auto-answer 4-8

Symbols

- \$B to change serial-port speeds 4-3
- \$D and diagnostics 4-20
- %G and protocol settings 4-12
- *H and cellular connections 4-7
- +++ to enter command state 4-6

Numerics

- 10-bit data characters A-16
- 10-bit data command A-16
- 11-bit data characters 4-2, A-16
- 11-bit data command A-16
- 11-bit data connections 4-6
- 2-second billing delay A-71

A

- ACE features 4-1
- ACE overview 4-17
- adaptive packet assembly 4-18
- advanced channel enhancements 4-1
- Adverse Channel Enhancements overview 4-17
- alarmsyslog parameter 2-15
- alternative B V.22 4-11
- analog lookback register A-58
- analog loopback
 - local 4-21, A-41
 - with self-test 4-20, A-41
- analog test commands A-40
- answer
 - interval A-54
- answer command A-3
- answer mode dial modifier A-9
- answer mode register A-57
- answer tone length register A-71

- answer tone register A-62
- answer tone timer A-64
- asynchronous mode register A-62
- asynchronous/synchronous time delay A-61
- AT
 - T17 and
 - T26 with cellular connections 4-8
 - T2 and auto-answer 4-8
- AT commands, introduction 4-3
- AT\$B to change serial-port speeds 4-3
- AT\$D and diagnostics 4-20
- AT%G and protocol setting 4-12
- AT&T BELLCORE calling card prompt A-11
- AT*H and cellular connections 4-7
- AT-E and 11-bit connections 4-6
- ATH to hang up 4-6
- attention sequence guard time A-56
- auto-answer and
 - T2 4-8
- auto-answer register A-51
- automatic fallback A-24
- automatic speed matching A-24
- auto-reliable
 - mode A-12, A-31
- auto-reliable buffer command A-6
- auto-reliable fallback character A-3
- auto-reliable mode dial modifier A-12
- auto-reliable mode, set A-30
- auto-retrain command A-16

B

- backspace character A-53
- Backspace key A-1
- Backspace key and commands 4-3
- Bell 103 connect messages 4-12
- Bell 103 overview 4-12
- Bell 212A A-59
- Bell 212A overview 4-12
- Bell/ITU-T command A-4
- BELLCORE bong detect modifier A-11
- bidirectional flow control, enable A-37

- bidirectional hardware flow control A-38
- bong detect dial modifier A-11
- bootstrap, display version A-44
- bps rate A-42
- bps rate adjust command A-21
- bps rate, modem port A-4
- bps rate, serial A-4
- break
 - transmit A-5
- break command A-5
- break control command A-22
- buffer delay command A-13
- buffer, setting auto-reliable A-6
- bypass parameter 2-16
- C**
- calling card dial modifier A-11
- carriage return character A-52
- carrier 4-27, A-6, A-43, A-54
- carrier detect A-14, A-55, A-59
- carrier detect by command A-6
- carrier detect response time A-55
- carrier loss delay register A-55
- CD A-6, A-14, A-55, A-59
- cell-side dial modifier A-9
- cellular calls, quick connect 4-7
- cellular connection dial modifiers A-9
- cellular connections 4-6
- cellular making connections A-28
- change
 - value of register A-50
- change serial port speed A-19
- changing serial-port speeds 4-3
- check parity A-35
- check parity command A-35
- clear serial port speed A-42
- CLI commands
 - stats user command ?? to 2-8
- command
 - state A-11, A-23, A-59
- command defaults, key 4-4
- command echo A-16
- command echo register A-57
- command state dial modifier A-11
- command, repeat last A-3
- command:prompt A-1
- command:set A-1
- commands
 - display firmware version A-43
 - to change registers A-50
 - to read registers A-50
- compatibility of V.FC and V.34 4-9
- compression control command A-5
- compression, data 4-17, A-5
- compromise equalizer command A-17
- configuration
 - register A-50, A-51
 - restoring default A-49
 - restoring saved A-18, A-45
 - storing complete A-46
- configuration registers, read S A-39
- configuration registers, reading A-39
- configuration, store A-45
- configuring a T1 connection 3-1
- connect
 - message 4-27, A-43
- connect message control A-6
- connect message control, CTS, DSR, CD A-6
- connect message delay timer A-68
- connect messages A-43, A-44
- connect state command A-33
- connection
 - training timer A-69
- connection speed reporting A-44
- connection training time, V.32 A-69
- credit card bong detect modifier A-11
- CTS A-6, A-14, A-39, A-59, A-61
- CTS control command A-14
- CTS off until connection A-37
- CTS turn-on delay timer A-69

D

- data buffering by command A-6
- data carrier detect by command A-6
- Data compression 4-17
- data compression A-5
- data echo A-17
- data echo command A-17
- data length
 - 10-bit characters A-16
 - 11-bit characters A-16
- data length command A-16
- DCD command A-6
- DCD command table A-15
- DCD delay timer A-65
- default settings A-2, A-18, A-49
- default user profile A-49
- defaults, key command 4-4
- defaults, restore A-18
- delay for hang up after carrier loss A-55
- delay for hangup after carrier loss A-55
- delay to DTR A-61
- designate default profile A-49
- designate default user profile A-49
- detect DTR command A-13
- detect phase command A-20
- Diagnostics
 - power-up 4-2
- diagnostics 4-19
- diagnostics and V.23 4-10
- diagnostics command A-40
- diagnostics register A-58
- diagnostics, power-up 4-20
- diagnostics, start power-up 4-20
- dial A-8
 - delay A-10
 - in answer mode A-9
 - in auto-reliable mode A-12
 - in LAPM mode A-9
 - in LAPM with fallback to MNP A-12
 - modifiers A-9
- dial by tone A-40
- dial delay register A-54
- dial in answer mode A-9
- dial in auto-reliable mode modifier A-12
- dial in direct mode modifier A-12
- dial in LAPM mode modifier A-11
- dial in normal mode modifier A-12
- dial in reliable mode modifier A-12
- dial method register A-57
- dial modifiers A-9
- dial modifiers, operating mode A-11
- dial pause modifier A-10
- dial pause register A-53
- dial stored number command A-12
- dial tone
 - wait for A-10
- dial tone delay modifier A-10
- dialing
 - pulse A-9, A-35
 - tone A-9
- dialing commands A-8
- digital loopback
 - local A-41
 - remote A-41
- digital loopback local 4-24
- digital loopback register A-58
- digital loopback remote 4-23
- digital test commands A-40
- direct mode A-30, A-38
- direct mode dial modifier A-12
- direct mode, set A-30
- directory A-14
- disable 2-second billing delay A-71
- disable bps rate adjust A-21
- disable compromise equalizer A-17
- disable data compression A-5
- disable detect phase A-20
- disable flow control A-37
- disable guard tone A-19
- disable MNP extended services A-22
- disable rate negotiation timer A-71
- disable result codes A-36

- disable secondary flow control A-18
- disable speed matching A-24
- disconnect buffer delay command A-13
- disconnect by command A-20
- display
 - configuration register A-51
 - registers A-39, A-51
- display connection speed A-44
- display firmware version A-43
- display modem identification A-20
- display modem settings A-40
- displaying commands A-16
- displaying registers A-39
- DSR A-6, A-14
- DSR control command A-14
- DSR options A-39
- DSR timer A-70
- DTMF tone dial speed A-56
- DTMF tone dialing speed A-56
- DTR A-59
 - control A-13
- DTR control command A-13
- DTR delay register A-61
- dumb mode register A-57
- dynamic transmit level adjustment 4-1

E

- E and 11-bit connections 4-6
- echo
 - command A-16
- echo data command A-17
- echoing commands A-16
- enable 10- or 11-bit data A-16
- enable 2-second billing delay A-71
- enable bps rate adjust A-21
- enable compromise equalizer A-17
- enable data compression A-5
- enable detect phase A-20
- enable guard tone A-19
- enable MNP extended services A-22
- enable result codes A-36
- enable secondary flow control A-18
- enable speed matching A-24
- end test in progress A-41
- enter command state with +++ 4-6
- enter connect state A-33
- Enter key and commands 4-3
- entering AT commands 4-3
- entering AT commands at any speed 4-3
- entering connect state A-33
- equalizer control, V.23 A-33
- equalizer retrain, begin A-33
- equalizer, compromise A-17
- error codes, long/short A-43
- error correction
 - LAPM A-20
 - MNP A-20
- error correction, MNP 4-17
- escape code
 - character A-52
- escape code, guard time A-56
- exclamation point A-10
- extended result codes A-47

F

- factory defaults, restore A-18
- factory default settings A-2, A-18, A-49
- fallback A-28
- fallback character, auto-reliable A-3
- fallback modulation speeds A-28, A-36
- false abort timer A-66
- features, modem 4-2
- firmware version display command A-20
- firmware version, display A-43
- flash dial modifier A-10
- flash memory
 - display bootstrap A-44
- flow control A-31
 - characters A-48, A-67
 - hardware A-37
 - primary XON character A-66
 - secondary XON character A-67

- serial port A-37
- XON/XOFF A-48
- flow control characters A-66
- flow control command A-37
- flow control enabling secondary characters A-18
- flow control, modem port A-19
- flow control, primary XOFF character A-67

G

- guard time, escape code A-56
- guard tone register A-60
- guard tone, disable A-19
- guard tone, set frequency A-19

H

- half-duplex and V.23 4-10
- handshaking in V.34 4-9
- hang up
 - delay A-55
- hang up by command 4-6, A-20
- hardware flow control
 - bidirectional A-38
- Hayes AT command set A-1

I

- identification command A-20
- ignore DTR command A-13
- inactivity timer command A-42
- independent serial/modem port speeds A-19
- ITU-T
 - V.21 4-2, A-64
 - V.22 4-2, A-59, A-64
 - V.22bis 4-2, A-24, A-59, A-64
 - V.23 4-2, A-17, A-64
 - half duplex A-63, A-64
 - V.23 half duplex A-65
 - V.32 4-2
 - V.54 4-24, A-41
- ITU-T/Bell command A-4

K

- Key AT command defaults 4-4

L

- landside data connections 4-7
- LAPM
 - connection A-22
 - reliable mode A-31, A-32
- LAPM and Bell 103 4-12
- LAPM connections and V.23 4-10
- LAPM mode dial modifier A-11
- LAPM modes, set A-30
- last command, repeat A-3
- last number redial command A-12
- line feed character A-53
- line probing in V.34 4-9
- line quality 4-9
- line turnaround timer A-64
- link negotiation dial modifier A-9
- link negotiation speed command A-20
- local analog loopback 4-21, A-41
 - with self-test A-41
- local analog loopback by command 4-21
- local analog loopback with self-test 4-20
- local analog loopback with self-test by command 4-20
- local digital loopback 4-24, A-41
- local digital loopback by command 4-24
- long form result codes A-43
- long space disconnect A-48, A-59
- loopback diagnostics and V.23 4-10
- loopback register A-58
- loopback respond register A-60
- loopback test commands A-40
- lost carrier to hang up delay A-55

M

- manual dial A-8
- map parameter 2-17
- mapping

- a modem to an interface 2-18
 - the two interfaces 2-20
- maximum MNP block size A-4
- messages, MNP A-28
- MNP A-4, A-22
 - class connect messages A-28
- MNP 3 4-18
- MNP 4 4-18
- MNP 6 4-18
- MNP 7 4-19
- MNP 9 4-19
- MNP classes 4-17
- MNP connect messages A-28
- MNP connections and V.23 4-10
- MNP error correction 4-17
- MNP extended services command A-22
- MNP result code form A-43
- MNP10 and cellular connections 4-6
- mode setting matrices 4-15
- modem features 4-2
- modem port
 - flow control A-19
 - speed A-4
 - testing 4-22, 4-23
- modem port data length A-16
- modem port test 4-24
- modem speed connection matrices 4-15
- modem-port bps rate A-4
- modulation protocols 4-8
- modulation speed command A-36
- multiple connection attempts 4-1
- multiple protocol answering command A-17
- multiple-protocol auto-answer 4-8
- multi-protocol timer A-63

N

- na
 - reset command 2-10
 - set command 2-12
 - show command 2-13
- negotiation in V.34 4-9

- negotiation speed, link A-20
- normal mode dial modifier A-12
- normal mode, set A-30
- numeric result codes A-43

O

- O/A register A-57
- off hook, forcing with ATA A-3
- OK response to commands 4-3
- on-line status, read A-40
- operating mode command A-30
- operating mode dial modifiers A-11
- optimized data phase 4-18
- originate mode register A-57

P

- parity check command A-35
- parity option register A-60
- parity, set by command A-34
- pause
 - before dial A-53
 - during dial A-10
 - for dial delay A-54
- pause dial modifier A-10
- pause time for dial delay A-54
- phone line quality 4-9
- point to new register A-51
- poor telephone line connections A-20
- port speed
 - modem A-4
 - serial A-19
- power
 - level, cellular A-28
- power levels for cellular calls A-28
- power-up diagnostics 4-2, 4-20
- power-up diagnostics, start 4-20
- primary XOFF character A-67
- primary XON character A-66
- printing conventions xiv
- product code display A-20
- prompt A-1

- protocol command settings 4-12
- protocol connection matrices 4-15
- protocols used by modem 4-2
- protocols, overview 4-8
- pulse dial command A-35
- pulse dial modifier A-9
- pulse dialing A-9
- pulse dialing, digits A-45
- pulse digit command A-45

Q

- quick connect cellular calls 4-7
- quiet answer A-10
- quiet command A-36
- quiet dial modifier A-10

R

- rate negotiation timer A-71
- reading
 - configuration register A-39, A-51
 - modem status A-40
- redial A-14
- redial last number command A-12
- register
 - commands A-50
 - display value of A-50
 - read all A-39, A-51
 - reading A-51
- register, change value A-50
- register, read S A-39
- registers, overview A-50
- registers, point to new A-51
- registers, read all A-51
- registers, read specific A-51
- registers, reading A-39
- reliable
 - connection A-5, A-6, A-7, A-43
 - link 4-27, A-4, A-43
- reliable mode dial modifier A-12
- reliable mode, set A-30
- remote digital loopback 4-23, A-41

- respond to A-41
 - with self-test A-41
- remote digital loopback by command 4-23
- remote digital loopback with self-test 4-22
- remote digital loopback, respond 4-25
- remote test commands A-40
- repeat dial A-14
- repeat dial command A-14
- repeat last command A-3
- reset
 - command A-49
- reset command 2-1, 2-10
 - reference 2-10
- reset int_modem command 2-11
- reset modem A-49
- respond to loopback register A-60
- respond to remote digital loopback 4-25, A-41
- restore
 - factory default settings A-49
 - saved configuration settings A-49
- restore factory default settings A-18
- result code form A-43
- result code register A-57
- result codes 4-26
 - extended A-47
 - long/short A-43
 - MNP A-43
 - on/off A-36
- result codes, extended A-47
- result codes, longhort A-43
- retrain A-16
- retrain command A-16
- retrain sequence A-33
- retrain, begin A-33
- return to command state modifier A-11
- ring
 - to auto-answer on A-51
- ring counter register A-52
- ring parameter 2-22
- ring to auto-answer on A-51
- ROM Monitor

- commands 3-1
- RTS A-39, A-59, A-61
- RTS/CTS options A-39

S

- S registers, displaying A-39
- S registers, overview A-50
- S registers, read A-39
- saved configuration settings A-45, A-49
- secondary XOFF character A-67
- secondary XON character A-67
- serial port
 - clear speed A-42
 - flow control A-31, A-37
 - speed A-21
- serial port bps rate A-4
- serial port DSR/CTS control A-14
- serial port parity command A-34
- serial port test 4-21, 4-22, 4-23, 4-24
- serial port, test 4-20
- serial-port DCD control A-6
- serial-port flow control A-37
- serial-port speed register A-60
- serial-port speed, clear A-42
- serial-port speeds, unlocking 4-3
- serial-port, speed display A-44
- set command 2-1, 2-12
 - reference 2-12
- setting protocols by commands 4-12
- settings, read current A-40
- short form result codes A-43
- show command 2-1, 2-13
 - reference 2-13
- sigproto parameter 2-23
- single cellular connection A-9
- SNMP 2-37
 - Annex parameters vs. Annex private enterprise MIB ?? to 2-37
- speed A-4
 - serial port A-19, A-21, A-42
 - speed connection matrices 4-15

- speed matching A-24
- speed matching command A-24
- speed reporting A-44
- speed selection, V.34/V.FC A-72
- speed, setting modem port A-4
- speed, setting serial port A-4
- speeds, cellular connection 4-6
- stats command
 - command display ?? to 2-7
 - reference ?? to 2-7
- stats -T command 2-1, 2-2
- status, read online A-40
- store
 - complete configuration settings A-46
- store current configuration A-45
- stored number dial command A-12
- switching between ITU-T and Bell A-4
- synchronous connections and V.21 4-11
- synchronous framing 4-18
- synchronous mode register A-62

T

- T registers, displaying A-39
- T registers, overview A-50
- t1 parameters 2-14
 - alarmsyslog 2-15
 - bypass 2-16
 - map 2-17
 - ring 2-22
 - sigproto 2-23
 - t1-info 2-26
 - tdi_distance 2-27
 - tdi_framing 2-28
 - tdi_line_code 2-29
 - tni_circuit_id 2-29, 2-30
 - tni_clock 2-31
 - tni_esf_fdl 2-32
 - tni_framing 2-33
 - tni_line_buildout 2-34
 - tni_line_code 2-35
 - tni_ones_density 2-36

- vs. MIB objects 2-37
 - t1_info parameter 2-26
 - t1_loopback command 2-1, 2-8
 - tdi_distance parameter 2-27
 - tdi_framing parameter 2-28
 - tdi_line_code parameter 2-29
 - telephone line quality 4-9
 - telephone numbers
 - dialing A-8
 - test command A-40
 - test timer register A-58
 - time delay
 - RTS to CTS A-61
 - time delay, asynchronous/synchronous A-61
 - time delay, DTR A-61
 - timer
 - connect message delay A-68
 - V.32/V.32bis A-69
 - timer command A-42
 - timer delay, false answer abort A-66
 - timer delay, turn CD on A-65
 - timer delay, V.23 half duplex intercharacter A-65
 - timer delay, V.23 half-duplex fallback A-63
 - timer for connect message delay A-68
 - timer for CTS turn-on delay A-69
 - timer for line turnaround A-64
 - timer for V.21 and V.23 answer tone A-64
 - timer for V.22, V.22bis, and V.32 A-62
 - tni_circuit_id parameter 2-30
 - tni_clock parameter 2-31
 - tni_esf_fdl parameter 2-32
 - tni_framing parameter 2-33
 - tni_line_buildout parameter 2-34
 - tni_line_code parameter 2-35
 - tni_ones_density parameter 2-36
 - tone dial modifier A-9
 - tone dialing A-9, A-40
 - tone dialing DTMF speed A-56
 - transmission mode
 - auto-reliable A-31
 - direct A-30, A-38
 - LAPM A-31, A-32
 - transmission mode register A-62
 - transmit break A-5
 - TST indicator A-16
- ## U
- universal link negotiation 4-19
 - unlocking serial-port speeds 4-3
 - user profile
 - store A-45
 - user profile. designate default A-49
- ## V
- V.21 4-2, A-64
 - V.21 overview 4-11
 - V.21 timer A-63
 - V.22 4-2, A-59, A-64
 - V.22 overview 4-11
 - V.22, V.22bis, V.32 timer A-62
 - V.22bis 4-2, A-59, A-64
 - V.22bis overview 4-11
 - V.23 4-2, A-64
 - equalizer control A-33
 - half duplex A-33, A-63, A-64, A-65
 - V.23 half-duplex 4-10
 - V.23 intercharacter delay timer A-65
 - V.23 line delay timer A-64
 - V.23 mode command A-17
 - V.23 protocol 4-10
 - V.24 control register A-68, A-70
 - V.32 4-2
 - V.32 training time A-69
 - V.32/V.32bis connection training timer A-69
 - V.32/V.32bis training time A-69
 - V.32bis A-69
 - V.32bis cellular connections 4-6
 - V.32bis overview 4-9
 - V.34 overview 4-8, 4-9
 - V.34/V.FC speed selection A-72
 - V.54 4-24, A-41
 - V.54 and V.23 4-10

- V.8 command A-24
- V.8 handshaking 4-9
- V.FC (V.fast Class) overview 4-8
- V.FC/V.34 compatibility 4-9
- verbose result codes A-43

W

- wait
 - before dialing A-10, A-53
 - for carrier after dial A-54
 - for dial tone before dialing A-54
 - for hang up after carrier loss A-55
 - for quiet answer A-10
- wait before dial A-53
- wait for carrier after dial A-54
- wait for dial tone A-10
- wait for quiet modifier A-10

X

- XON character A-66
- XON/XOFF flow control A-19, A-48
- XON/XOFF pass-through A-48
- XON/XON, enable A-37